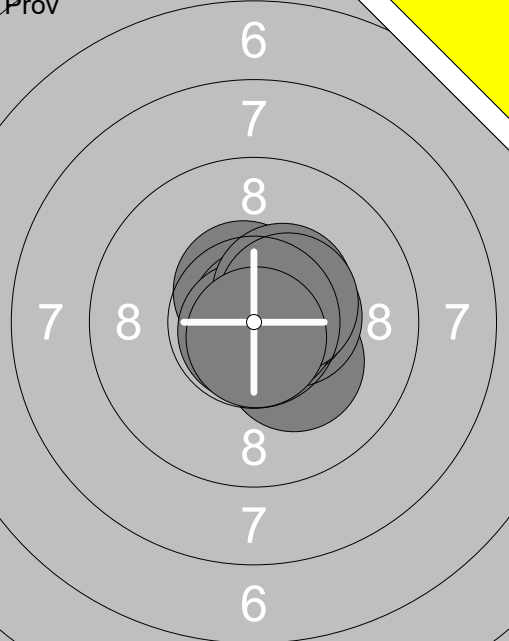
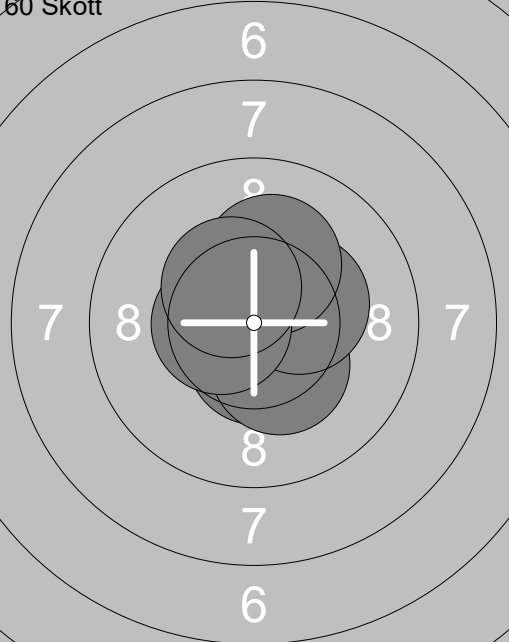
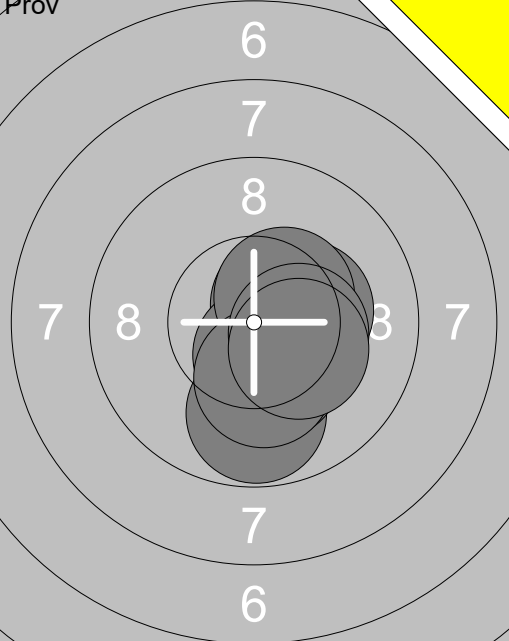
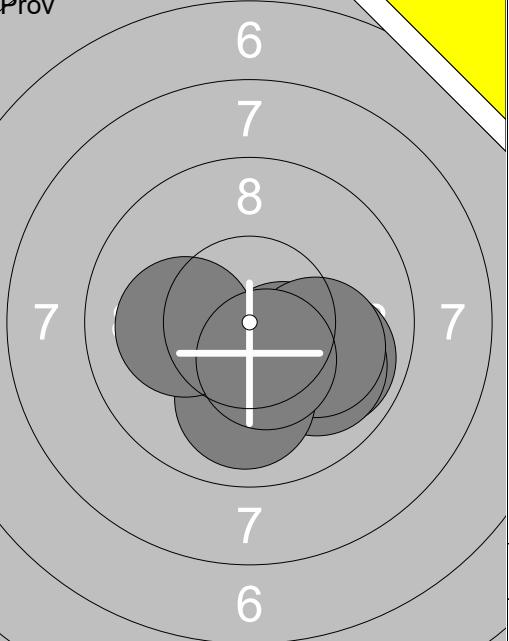
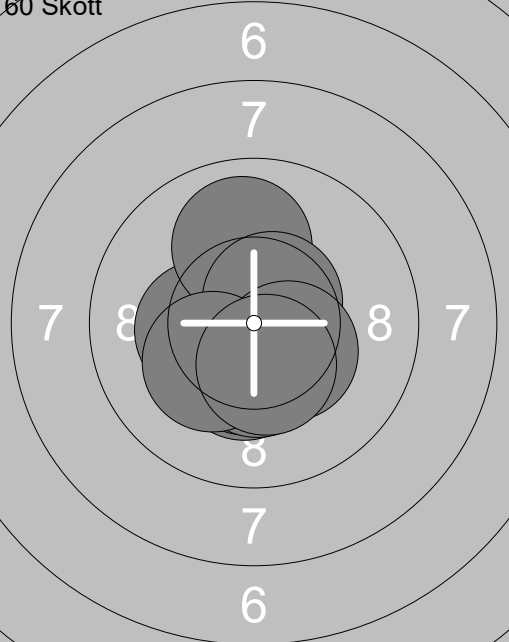

<p>Prov</p> 	<p>1: 10.2x↘ 2: 10.5x→ 3: 10.5x↗ 4: 10.6x→ 5: 10.8x↗ 6: 10.8x→ 7: 10.8x↘ 8: 10.4x↗ 9: 10.5x→ 10: 10.8x↘</p> <table border="1" style="width:100%; border-collapse: collapse;"> <tr><td>Serie</td><td style="text-align: right;">100.0</td></tr> <tr><td>Total</td><td style="text-align: right;">0.0</td></tr> </table>	Serie	100.0	Total	0.0	<p>Prov</p> 	<p>11: 10.4x→ 12: 10.6x↘</p> <table border="1" style="width:100%; border-collapse: collapse;"> <tr><td>Serie</td><td style="text-align: right;">20.0</td></tr> <tr><td>Total</td><td style="text-align: right;">0.0</td></tr> </table>	Serie	20.0	Total	0.0
Serie	100.0										
Total	0.0										
Serie	20.0										
Total	0.0										

<p>60 Skott</p> 	<p>1: 10.7x↗ 2: 10.7x↗ 3: 10.4x↗ 4: 10.5x↘ 5: 10.3x↘ 6: 10.4x↗ 7: 10.3x→ 8: 10.2x↗ 9: 10.5x← 10: 10.4x↘</p> <table border="1" style="width:100%; border-collapse: collapse;"> <tr><td>Serie</td><td style="text-align: right;">100.0</td></tr> <tr><td>Total</td><td style="text-align: right;">100.0</td></tr> </table>	Serie	100.0	Total	100.0	<p>60 Skott</p> 	<p>11: 10.6x↘ 12: 10.5x↘ 13: 10.4x↘ 14: 10.8x↘ 15: 10.5x→ 16: 10.9x↗ 17: 10.8x↗ 18: 10.8x← 19: 10.9x↗ 20: 10.7x↘</p> <table border="1" style="width:100%; border-collapse: collapse;"> <tr><td>Serie</td><td style="text-align: right;">100.0</td></tr> <tr><td>Total</td><td style="text-align: right;">200.0</td></tr> </table>	Serie	100.0	Total	200.0
Serie	100.0										
Total	100.0										
Serie	100.0										
Total	200.0										

<p>60 Skott</p> 	<p>21: 10.8x↘ 22: 10.7x↘ 23: 10.8x← 24: 10.7x↘ 25: 10.7x↘ 26: 10.5x↗ 27: 10.5x↘ 28: 10.5x↘ 29: 10.4x↘ 30: 10.7x↗</p> <table border="1" style="width:100%; border-collapse: collapse;"> <tr><td>Serie</td><td style="text-align: right;">100.0</td></tr> <tr><td>Total</td><td style="text-align: right;">300.0</td></tr> </table>	Serie	100.0	Total	300.0	<p>60 Skott</p> 	<p>31: 10.5x↘ 32: 10.5x↘ 33: 10.6x→ 34: 10.5x→ 35: 10.8x↗ 36: 10.6x↘ 37: 10.7x↘ 38: 10.3x↘ 39: 10.6x↘ 40: 10.4x←</p> <table border="1" style="width:100%; border-collapse: collapse;"> <tr><td>Serie</td><td style="text-align: right;">100.0</td></tr> <tr><td>Total</td><td style="text-align: right;">400.0</td></tr> </table>	Serie	100.0	Total	400.0
Serie	100.0										
Total	300.0										
Serie	100.0										
Total	400.0										

Prov 	1: 10.5x↗ 2: 10.5x↓ 3: 10.3x→ 4: 9.8 ↓ 5: 10.5x↓ 6: 10.3x↓ 7: 10.5x↗ 8: 10.2x↓ 9: 10.4x→ 10: 10.3x↘ <hr/> Serie 99.0 Total 0.0	Prov 	11: 9.9 → 12: 9.9 ↘ 13: 10.4x↘ 14: 10.0 → 15: 10.0 ↓ 16: 10.1 ← 17: 10.4x↓ <hr/> Serie 68.0 Total 0.0
--	---	--	---

60 Skott 	1: 10.6x↓ 2: 10.3x↓ 3: 10.3x↔ 4: 10.4x↓ 5: 10.4x↓ 6: 10.0 ↑ 7: 10.6x↗ 8: 10.4x↘ 9: 10.2x↘ 10: 10.4x↓ <hr/> Serie 100.0 Total 100.0	60 Skott 	11: 10.4x↘ 12: 10.5x↓ 13: 10.0 ↙ 14: 9.7 ↓ 15: 10.6x↘ 16: 10.4x↓ 17: 10.4x↗ 18: 10.5x↓ 19: 10.6x↔ 20: 10.4x↔ <hr/> Serie 99.0 Total 199.0
---	---	---	--

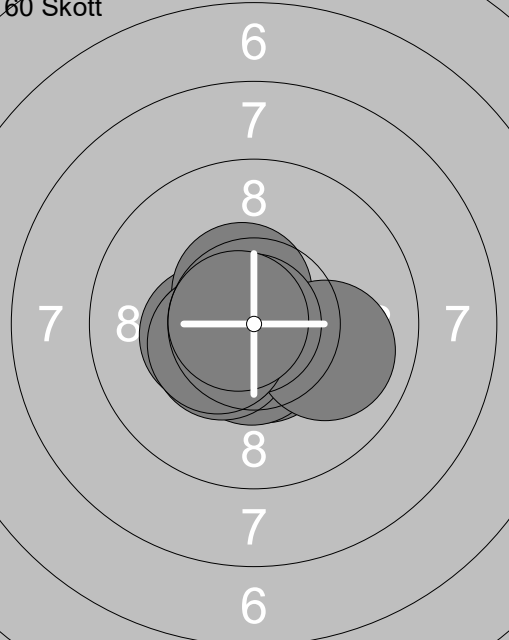
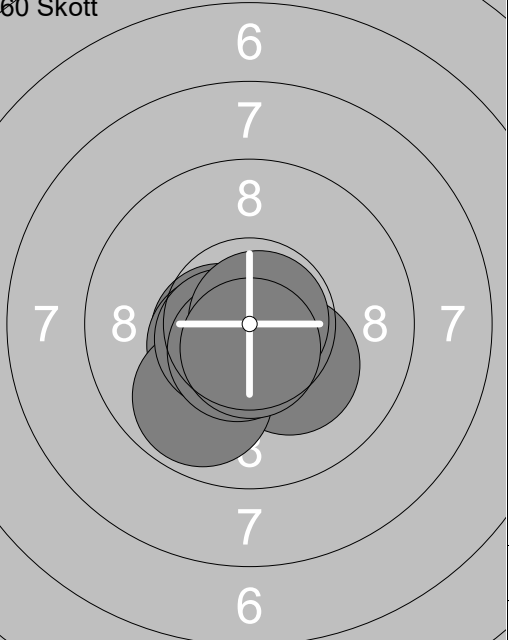
60 Skott 	21: 10.6x↓ 22: 10.6x↓ 23: 10.4x↔ 24: 10.4x↘ 25: 10.5x↘ 26: 10.5x↗ 27: 10.0 → 28: 10.9x↔ 29: 10.4x↘ 30: 10.7x↔ <hr/> Serie 100.0 Total 299.0	60 Skott 	31: 10.6x↔ 32: 10.5x↘ 33: 10.5x↘ 34: 10.2x↘ 35: 9.8 ↓ 36: 10.7x↓ 37: 10.6x↘ 38: 10.6x↓ 39: 10.8x→ 40: 10.6x↓ <hr/> Serie 99.0 Total 398.0
--	--	--	--

<p>Prov</p> 	<p>1: 10.4x ➤</p> <p>2: 9.6 ➔</p> <p>3: 9.9 ↙</p> <p>4: 10.2x ↗</p> <p>5: 10.5x ↘</p>	<p>60 Skott</p> 		<p>1: 10.5x ←</p> <p>2: 9.8 ↗</p> <p>3: 9.5 ↙</p> <p>4: 10.1 ↖</p> <p>5: 10.1 ↖</p> <p>6: 10.3x ←</p> <p>7: 10.2x ↘</p> <p>8: 10.3x ↘</p> <p>9: 9.9 ↖</p> <p>10: 8.7 ➔</p>	
Serie	48.0			Serie	95.0
Total	0.0			Total	95.0

<p>60 Skott</p> 	<p>11: 8.8 ↖</p> <p>12: 9.3 ↖</p> <p>13: 10.2x ↘</p> <p>14: 7.4 ➔</p> <p>15: 5.0 ↘</p> <p>16: 8.8 ➔</p> <p>17: 9.4 ➔</p> <p>18: 10.0 ↗</p> <p>19: 10.4x ↗</p> <p>20: 10.1 ↗</p>	<p>60 Skott</p> 		<p>21: 8.2 ↖</p> <p>22: 10.4x ↘</p> <p>23: 9.9 ←</p> <p>24: 9.3 ↗</p> <p>25: 10.6x ↗</p> <p>26: 10.0 ↗</p> <p>27: 9.4 ➔</p> <p>28: 10.4x ↘</p> <p>29: 10.8x ←</p> <p>30: 10.1 ↘</p>	
Serie	86.0			Serie	95.0
Total	181.0			Total	276.0

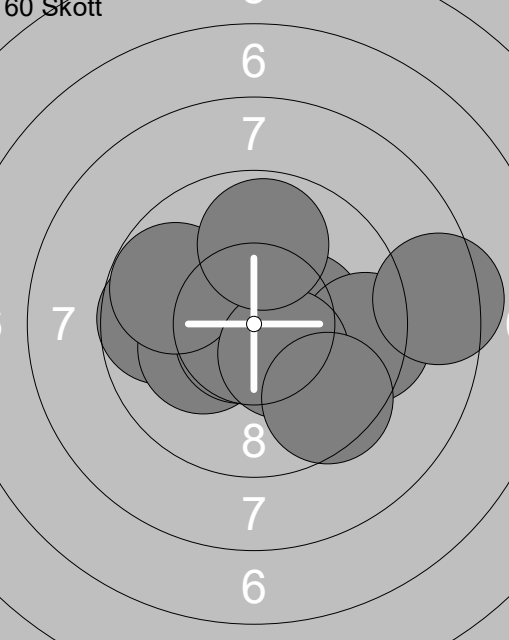
<p>60 Skott</p> 	<p>31: 10.3x ➤</p> <p>32: 9.4 ➔</p> <p>33: 9.7 ←</p> <p>34: 10.2x ←</p> <p>35: 10.7x ↙</p> <p>36: 8.4 ➔</p> <p>37: 9.8 ↖</p> <p>38: 10.4x ↘</p> <p>39: 9.9 ↖</p> <p>40: 9.5 ↘</p>			
Serie	93.0			
Total	369.0			

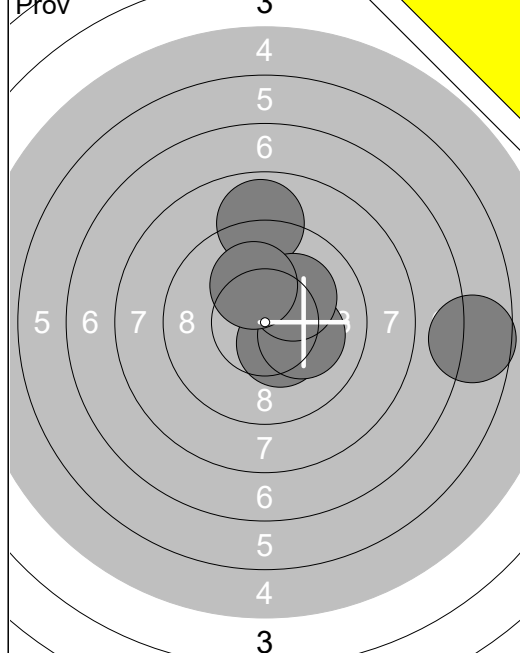

1:	10.4x ↘
2:	10.2x →
3:	8.9 ↑
4:	10.2x ↗
5:	6.7 →
6:	10.2x ↗
Serie 54.0	
Total 0.0	

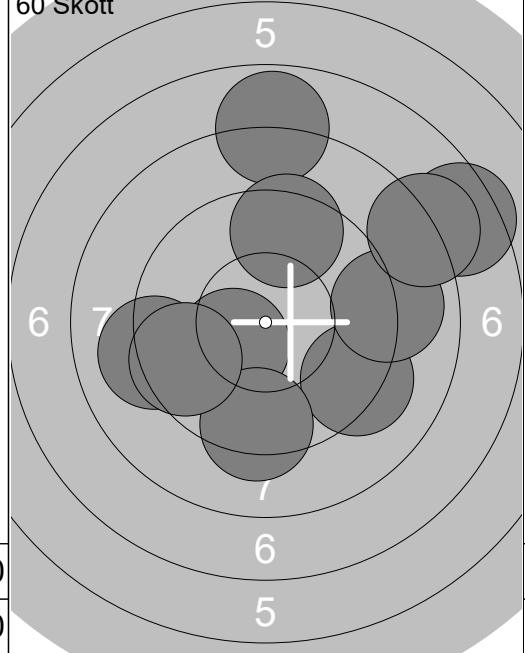

1:	9.2 ↘
2:	9.1 ←
3:	7.5 ↗
4:	9.0 →
5:	10.3x ↘
6:	9.3 ↓
7:	9.5 ←
8:	7.9 ↑
9:	8.0 ↗
10:	9.5 ↑
Serie 86.0	
Total 86.0	

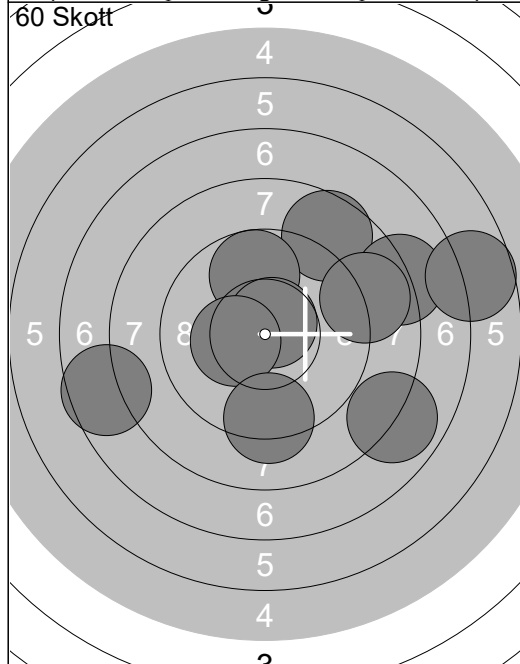

11:	7.9 ↘
12:	7.6 ←
13:	8.6 ↗
14:	9.8 ↑
15:	8.1 →
16:	10.7x ↗
17:	6.7 →
18:	10.3x ←
19:	8.8 →
20:	9.3 ↓
Serie 82.0	
Total 168.0	

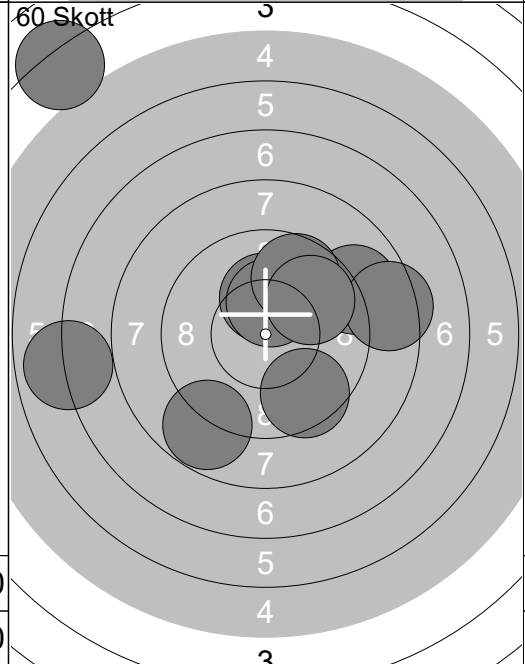

21:	9.5 ↘
22:	10.2x ↗
23:	4.1 ↖
24:	8.8 ↘
25:	9.0 →
26:	10.3x ↗
27:	9.7 ↗
28:	8.4 →
29:	9.8 ↗
30:	6.9 ←
Serie 82.0	
Total 250.0	

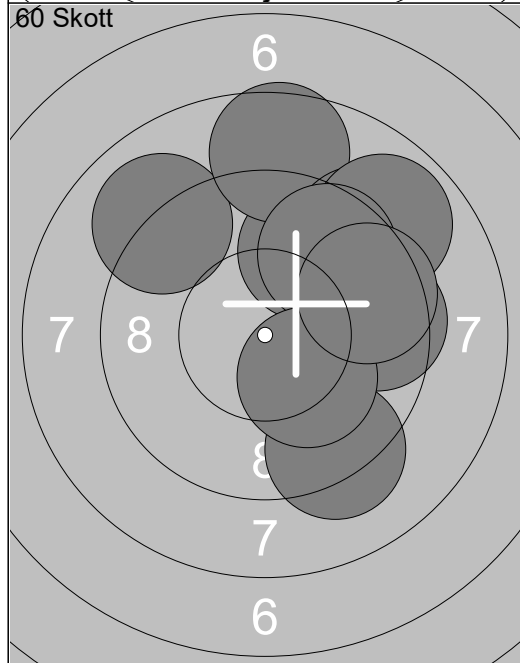

31:	9.7 ↗
32:	9.5 →
33:	9.0 ↖
34:	8.6 ↑
35:	9.2 ↗
36:	8.9 ↗
37:	9.6 ↗
38:	9.2 ↓
39:	10.2x ↘
40:	9.5 →
Serie 89.0	
Total 339.0	

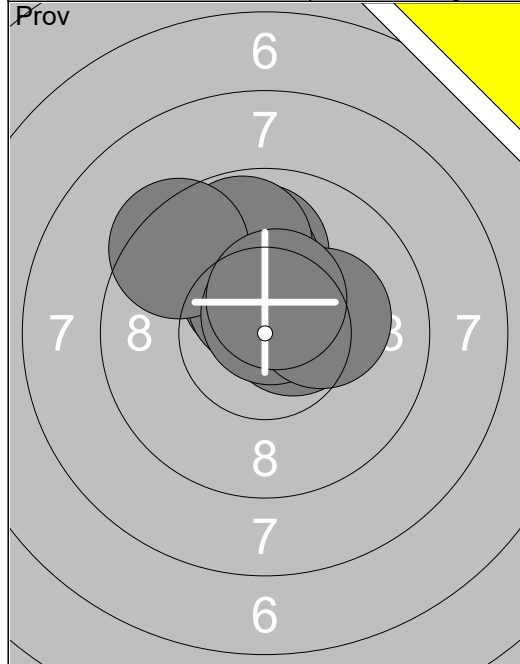

1:	10.6x➤
2:	9.9 ↑
3:	10.4x↗
4:	10.1 ↑
5:	10.5x↗
6:	9.8 ↑
7:	9.4 ↙
8:	10.7x↗
9:	10.2x➤
10:	10.5x↗
Serie	97.0
Total	0.0

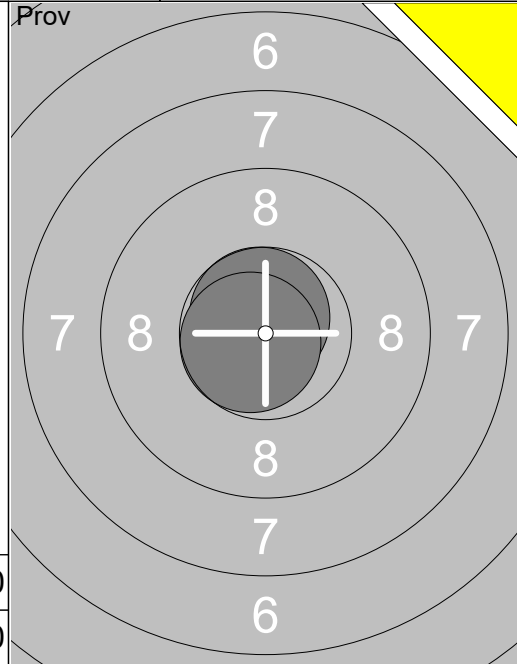

11:	10.7x↗
12:	10.7x↙
Serie	20.0
Total	0.0

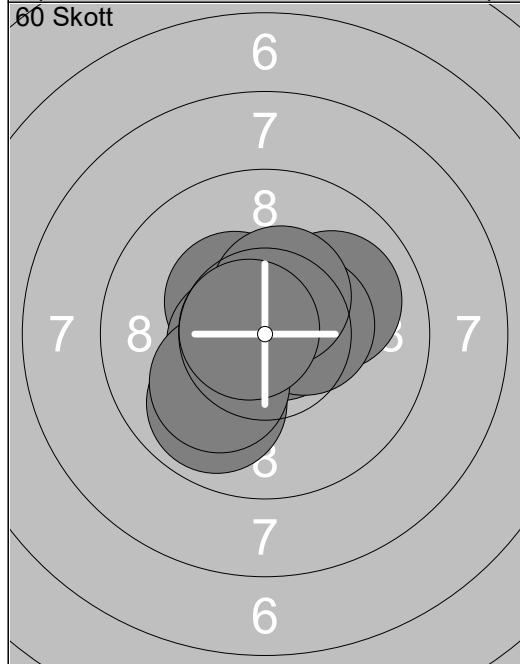

1:	10.4x↙
2:	10.5x↗
3:	10.0 ➤
4:	9.9 ↙
5:	10.6x↙
6:	10.8x➤
7:	10.4x➤
8:	10.1 ↙
9:	10.4x↗
10:	10.7x↙
Serie	99.0
Total	99.0

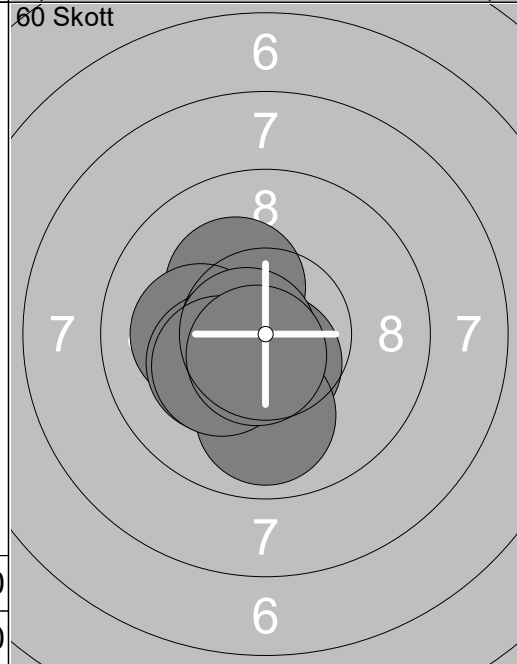

11:	10.2x↙
12:	10.1 ←
13:	10.6x↘
14:	10.6x↘
15:	10.5x↙
16:	10.2x↙
17:	9.9 ↓
18:	10.7x↙
19:	10.3x↙
20:	10.7x↘
Serie	99.0
Total	198.0

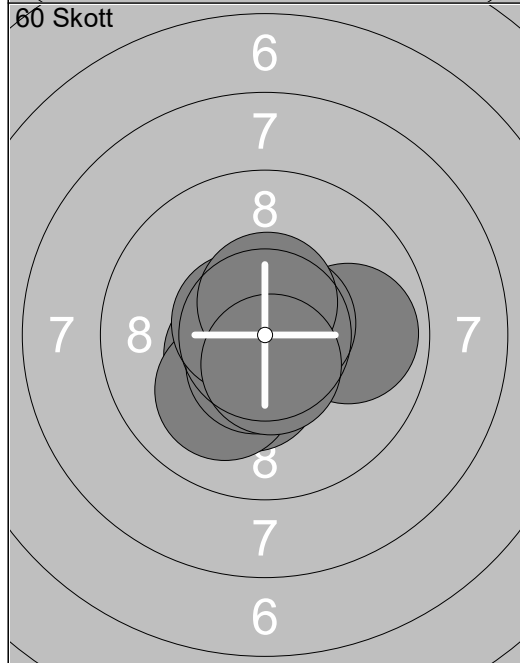

21:	10.3x↘
22:	10.5x↙
23:	10.1 ↙
24:	10.6x↘
25:	10.7x↗
26:	9.9 ➤
27:	10.6x↙
28:	10.7x➤
29:	10.5x↗
30:	10.6x↘
Serie	99.0
Total	297.0

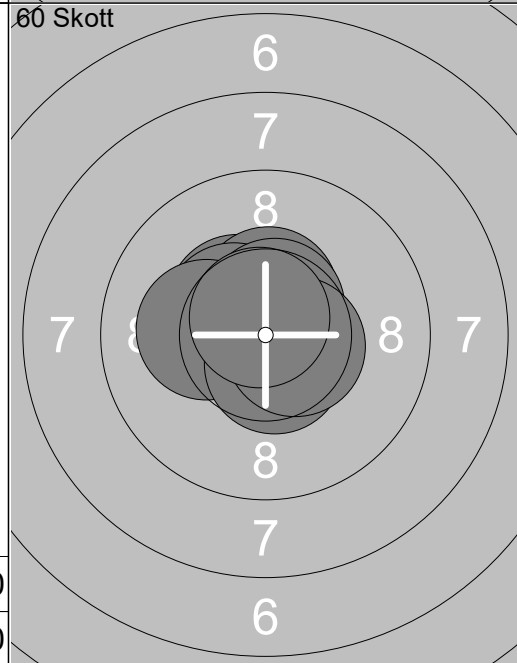

31:	10.8x↙
32:	10.5x↙
33:	10.4x↙
34:	10.5x↗
35:	10.5x↙
36:	10.2x↙
37:	10.6x↗
38:	10.6x↘
39:	10.5x➤
40:	10.7x↗
Serie	100.0
Total	397.0

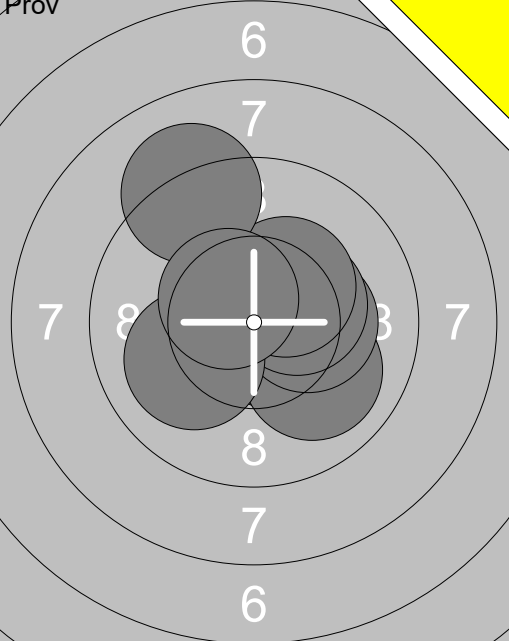
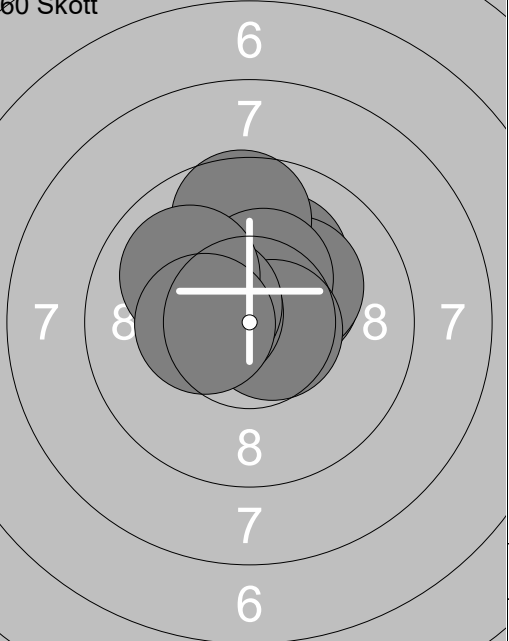
<p>Prov</p> 	<p>1: 10.5x ➤</p> <p>2: 10.5x ➤</p> <p>3: 10.0 ➤</p> <p>4: 10.3x ➤</p> <p>5: 10.4x ➤</p> <p>6: 10.3x ↗</p> <p>7: 10.1 ↙</p> <p>8: 9.1 ↑</p> <p>9: 10.5x ↘</p>	<p>60 Skott</p> 	<p>1: 10.1 ↗</p> <p>2: 10.3x ↗</p> <p>3: 10.2x ↗</p> <p>4: 9.6 ↑</p> <p>5: 10.4x ↗</p> <p>6: 10.6x ➤</p> <p>7: 10.5x ↘</p> <p>8: 10.4x ↘</p> <p>9: 10.0 ↙</p> <p>10: 10.4x ↘</p>
Serie 89.0		Serie 99.0	
Total 0.0		Total 99.0	

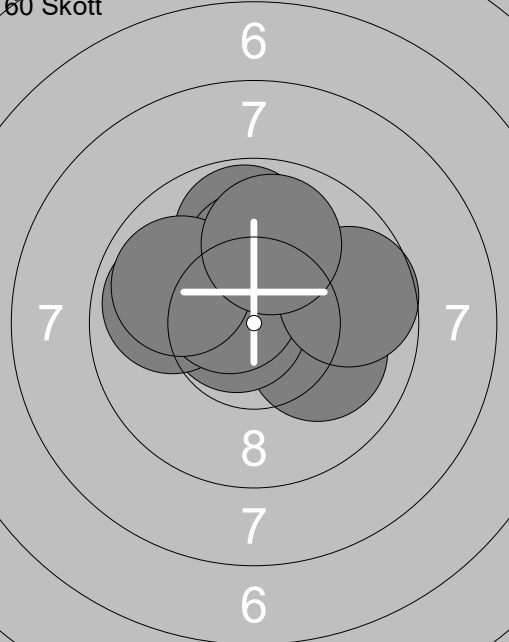
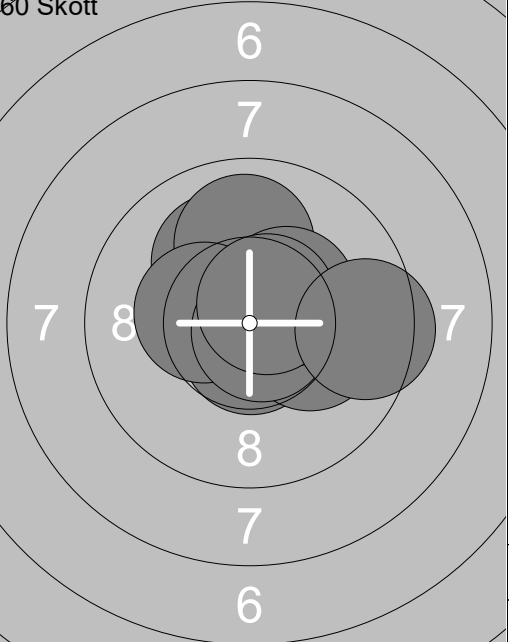
<p>60 Skott</p> 	<p>11: 10.4x ↘</p> <p>12: 10.1 ➤</p> <p>13: 9.8 ↑</p> <p>14: 10.7x ↘</p> <p>15: 9.9 ←</p> <p>16: 10.2x ↗</p> <p>17: 10.6x ↘</p> <p>18: 9.9 ←</p> <p>19: 9.7 ➤</p> <p>20: 9.9 ↑</p>	<p>60 Skott</p> 	<p>21: 10.1 ↘</p> <p>22: 10.4x ➤</p> <p>23: 9.9 ↑</p> <p>24: 10.7x ↘</p> <p>25: 10.4x ↘</p> <p>26: 10.1 ➤</p> <p>27: 10.8x ↘</p> <p>28: 10.4x ↗</p> <p>29: 10.6x ↗</p> <p>30: 9.5 ➤</p>
Serie 95.0		Serie 98.0	
Total 194.0		Total 292.0	

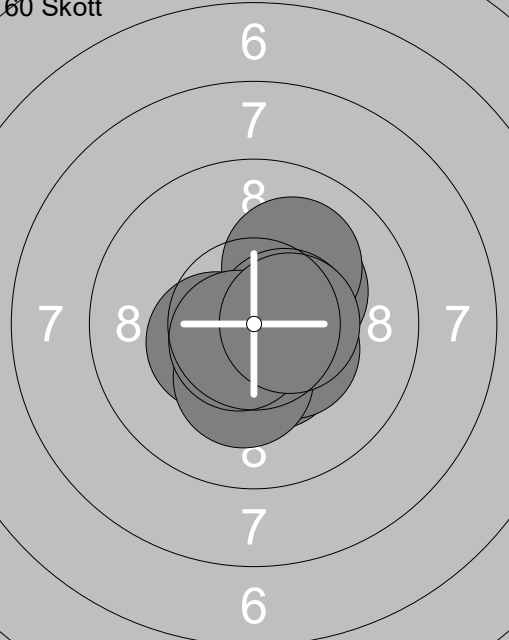
<p>60 Skott</p> 	<p>31: 10.4x ↘</p> <p>32: 10.3x ↗</p> <p>33: 10.6x ↘</p> <p>34: 10.1 ↗</p> <p>35: 10.4x ↘</p> <p>36: 10.4x ↘</p> <p>37: 10.6x ➤</p> <p>38: 10.2x ↘</p> <p>39: 10.7x ↘</p> <p>40: 10.5x ➤</p>		
Serie 100.0			
Total 392.0			

<p>Prov</p>	<p>1: 5.8 ←</p> <p>2: 8.4 ↗</p> <p>3: 2.3 →</p> <p>4: 4.4 ↓</p> <p>5: 5.7 →</p> <p>6: 8.5 ←</p> <p>7: 4.5 →</p> <p>8: 2.0 ↓</p> <p>9: 10.4x ↗</p> <p>10: 2.3 ↓</p>	<p>Prov</p>	<p>11: 6.4 ↗</p>
Serie 50.0		Serie 6.0	
Total 0.0		Total 0.0	

<p>60 Skott</p>	<p>1: 9.5 ←</p> <p>2: 4.7 ↗</p> <p>3: 7.8 →</p> <p>4: 10.5x ↗</p> <p>5: 8.7 ↗</p> <p>6: 5.8 →</p> <p>7: 9.3 →</p> <p>8: 9.9 ←</p> <p>9: 5.7 ↓</p> <p>10: 10.2x ↗</p>	<p>60 Skott</p>	<p>11: 10.2x ↓</p> <p>12: 10.6x ↗</p> <p>13: 4.3 ↖</p> <p>14: 8.6 →</p> <p>15: 8.1 ↑</p> <p>16: 7.6 ↗</p> <p>17: 10.3x ↓</p> <p>18: 8.3 ↓</p> <p>19: 6.5 →</p> <p>20: 8.1 ↖</p>
Serie 76.0		Serie 79.0	
Total 76.0		Total 155.0	

<p>60 Skott</p>	<p>21: 8.6 →</p> <p>22: 10.2x ↓</p> <p>23: 9.0 ↑</p> <p>24: 5.3 ↑</p> <p>25: 6.7 ↖</p> <p>26: 10.3x ↗</p> <p>27: 9.0 ↑</p> <p>28: 7.4 ←</p> <p>29: 10.6x ↓</p> <p>30: 8.8 ←</p>	<p>60 Skott</p>	<p>31: 7.1 ↗</p> <p>32: 8.5 ↓</p> <p>33: 7.4 ↖</p> <p>34: 3.8 ↓</p> <p>35: 6.8 ↑</p> <p>36: 9.1 ↖</p> <p>37: 9.5 ↖</p> <p>38: 5.4 ↖</p> <p>39: 9.3 ↗</p> <p>40: 9.9 ↑</p>
Serie 82.0		Serie 72.0	
Total 237.0		Total 309.0	

Prov 	1: 10.6x 2: 10.3x 3: 10.5x 4: 10.1 5: 10.2x 6: 10.5x 7: 10.7x 8: 10.7x 9: 10.2x 10: 10.5x <hr/> Serie 100.0 Total 0.0	Prov 	11: 10.7x <hr/> Serie 10.0 Total 0.0
--	--	--	--

60 Skott 	1: 10.5x 2: 10.5x 3: 10.3x 4: 10.9x 5: 10.7x 6: 10.4x 7: 10.1 8: 10.3x 9: 10.3x 10: 10.8x <hr/> Serie 100.0 Total 100.0	60 Skott 	11: 10.7x 12: 10.3x 13: 10.4x 14: 10.3x 15: 10.5x 16: 10.6x 17: 10.1 18: 10.2x 19: 10.7x 20: 10.6x <hr/> Serie 100.0 Total 200.0
---	--	---	---

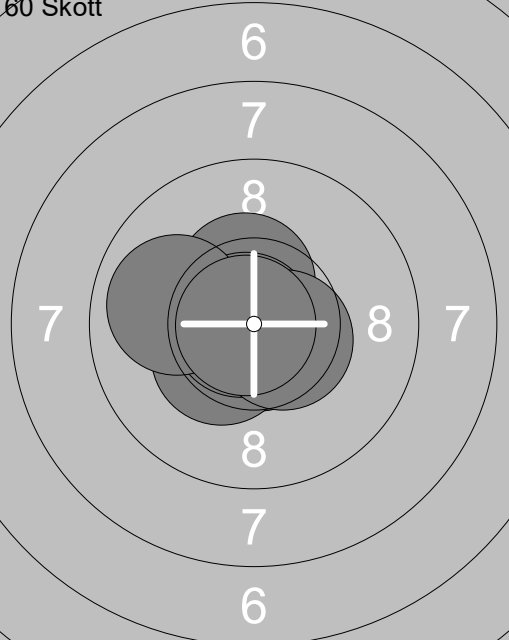
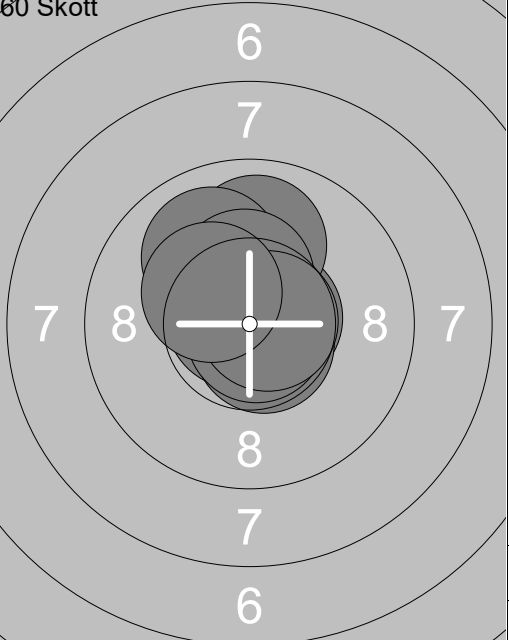
60 Skott 	21: 10.7x 22: 10.7x 23: 10.8x 24: 10.4x 25: 10.4x 26: 10.8x 27: 10.8x 28: 9.9 29: 10.5x 30: 10.8x <hr/> Serie 99.0 Total 299.0	60 Skott 	31: 10.6x 32: 10.8x 33: 10.6x 34: 9.9 35: 10.8x 36: 10.0 37: 10.6x 38: 10.4x 39: 10.7x 40: 10.3x <hr/> Serie 99.0 Total 398.0
--	---	--	--

<p>Prov</p>	<p>1: 10.6x ↖</p> <p>2: 10.6x ➔</p> <p>3: 10.1 ↘</p> <p>4: 10.4x ➔</p> <p>5: 10.3x ↙</p> <p>6: 10.4x ↘</p> <p>7: 10.7x ➔</p> <p>8: 10.6x ↗</p>	<p>60 Skott</p>	<p>1: 10.7x ➔</p> <p>2: 10.6x ↗</p> <p>3: 10.2x ↖</p> <p>4: 10.8x ➔</p> <p>5: 10.1 ↗</p> <p>6: 10.7x ↙</p> <p>7: 10.3x ↖</p> <p>8: 10.3x ↘</p> <p>9: 10.2x ↗</p> <p>10: 10.5x ↖</p>
Serie 80.0		Serie 100.0	
Total 0.0		Total 100.0	

<p>60 Skott</p>	<p>11: 9.9 ↗</p> <p>12: 10.4x ↘</p> <p>13: 10.6x ↙</p> <p>14: 9.9 ↗</p> <p>15: 10.6x ↖</p> <p>16: 9.8 ↘</p> <p>17: 10.3x ↖</p> <p>18: 10.0 ↖</p> <p>19: 10.5x ↗</p> <p>20: 10.7x ↖</p>	<p>60 Skott</p>	<p>21: 10.5x ↖</p> <p>22: 10.1 ↖</p> <p>23: 10.6x ↗</p> <p>24: 10.8x ↘</p> <p>25: 9.5 ↗</p> <p>26: 10.8x ↖</p> <p>27: 10.4x ↖</p> <p>28: 9.4 ↖</p> <p>29: 10.6x ↖</p> <p>30: 9.7 ↖</p>
Serie 97.0		Serie 97.0	
Total 197.0		Total 294.0	

<p>60 Skott</p>	<p>31: 10.6x ➔</p> <p>32: 10.9x ↗</p> <p>33: 10.1 ↗</p> <p>34: 10.8x ↖</p> <p>35: 10.8x ↖</p> <p>36: 10.7x ➔</p> <p>37: 10.5x ↙</p> <p>38: 10.3x ↖</p> <p>39: 10.3x ↙</p> <p>40: 10.4x ↖</p>		
Serie 100.0			
Total 394.0			

<p>Pröv</p>	<table style="width:100%; border-collapse: collapse;"> <tr><td>1:</td><td>10.1</td><td>↘</td></tr> <tr><td>2:</td><td>10.3x</td><td>↘</td></tr> <tr><td>3:</td><td>10.0</td><td>←</td></tr> <tr><td>4:</td><td>10.5x</td><td>↘</td></tr> <tr><td>5:</td><td>10.6x</td><td>←</td></tr> <tr><td>6:</td><td>10.4x</td><td>→</td></tr> <tr><td>7:</td><td>10.6x</td><td>↘</td></tr> <tr><td>8:</td><td>10.3x</td><td>→</td></tr> <tr><td>9:</td><td>10.5x</td><td>↘</td></tr> <tr><td>10:</td><td>10.5x</td><td>→</td></tr> <tr><td colspan="2">Serie</td><td style="text-align: right;">100.0</td></tr> <tr><td colspan="2">Total</td><td style="text-align: right;">0.0</td></tr> </table>	1:	10.1	↘	2:	10.3x	↘	3:	10.0	←	4:	10.5x	↘	5:	10.6x	←	6:	10.4x	→	7:	10.6x	↘	8:	10.3x	→	9:	10.5x	↘	10:	10.5x	→	Serie		100.0	Total		0.0	<p>Pröv</p>	<table style="width:100%; border-collapse: collapse;"> <tr><td>11:</td><td>10.6x</td><td>↓</td></tr> <tr><td>12:</td><td>10.3x</td><td>↗</td></tr> <tr><td>13:</td><td>10.9x</td><td>↗</td></tr> <tr><td>14:</td><td>10.8x</td><td>↘</td></tr> <tr><td>15:</td><td>10.8x</td><td>→</td></tr> <tr><td>16:</td><td>10.7x</td><td>↖</td></tr> <tr><td>17:</td><td>10.7x</td><td>↑</td></tr> <tr><td>18:</td><td>10.2x</td><td>↓</td></tr> <tr><td>19:</td><td>10.4x</td><td>↗</td></tr> <tr><td>20:</td><td>9.5</td><td>←</td></tr> <tr><td colspan="2">Serie</td><td style="text-align: right;">99.0</td></tr> <tr><td colspan="2">Total</td><td style="text-align: right;">0.0</td></tr> </table>	11:	10.6x	↓	12:	10.3x	↗	13:	10.9x	↗	14:	10.8x	↘	15:	10.8x	→	16:	10.7x	↖	17:	10.7x	↑	18:	10.2x	↓	19:	10.4x	↗	20:	9.5	←	Serie		99.0	Total		0.0
1:	10.1	↘																																																																									
2:	10.3x	↘																																																																									
3:	10.0	←																																																																									
4:	10.5x	↘																																																																									
5:	10.6x	←																																																																									
6:	10.4x	→																																																																									
7:	10.6x	↘																																																																									
8:	10.3x	→																																																																									
9:	10.5x	↘																																																																									
10:	10.5x	→																																																																									
Serie		100.0																																																																									
Total		0.0																																																																									
11:	10.6x	↓																																																																									
12:	10.3x	↗																																																																									
13:	10.9x	↗																																																																									
14:	10.8x	↘																																																																									
15:	10.8x	→																																																																									
16:	10.7x	↖																																																																									
17:	10.7x	↑																																																																									
18:	10.2x	↓																																																																									
19:	10.4x	↗																																																																									
20:	9.5	←																																																																									
Serie		99.0																																																																									
Total		0.0																																																																									

<p>Pröv</p>	<table style="width:100%; border-collapse: collapse;"> <tr><td>21:</td><td>10.3x</td><td>↘</td></tr> <tr><td>22:</td><td>10.3x</td><td>←</td></tr> <tr><td>23:</td><td>10.6x</td><td>↘</td></tr> <tr><td colspan="2">Serie</td><td style="text-align: right;">30.0</td></tr> <tr><td colspan="2">Total</td><td style="text-align: right;">0.0</td></tr> </table>	21:	10.3x	↘	22:	10.3x	←	23:	10.6x	↘	Serie		30.0	Total		0.0	<p>60 Skott</p>	<table style="width:100%; border-collapse: collapse;"> <tr><td>1:</td><td>10.3x</td><td>↘</td></tr> <tr><td>2:</td><td>10.6x</td><td>←</td></tr> <tr><td>3:</td><td>10.9x</td><td>↑</td></tr> <tr><td>4:</td><td>10.3x</td><td>→</td></tr> <tr><td>5:</td><td>9.9</td><td>←</td></tr> <tr><td>6:</td><td>10.6x</td><td>↖</td></tr> <tr><td>7:</td><td>10.2x</td><td>↓</td></tr> <tr><td>8:</td><td>10.5x</td><td>↘</td></tr> <tr><td>9:</td><td>10.2x</td><td>→</td></tr> <tr><td>10:</td><td>10.0</td><td>→</td></tr> <tr><td colspan="2">Serie</td><td style="text-align: right;">99.0</td></tr> <tr><td colspan="2">Total</td><td style="text-align: right;">99.0</td></tr> </table>	1:	10.3x	↘	2:	10.6x	←	3:	10.9x	↑	4:	10.3x	→	5:	9.9	←	6:	10.6x	↖	7:	10.2x	↓	8:	10.5x	↘	9:	10.2x	→	10:	10.0	→	Serie		99.0	Total		99.0
21:	10.3x	↘																																																				
22:	10.3x	←																																																				
23:	10.6x	↘																																																				
Serie		30.0																																																				
Total		0.0																																																				
1:	10.3x	↘																																																				
2:	10.6x	←																																																				
3:	10.9x	↑																																																				
4:	10.3x	→																																																				
5:	9.9	←																																																				
6:	10.6x	↖																																																				
7:	10.2x	↓																																																				
8:	10.5x	↘																																																				
9:	10.2x	→																																																				
10:	10.0	→																																																				
Serie		99.0																																																				
Total		99.0																																																				

<p>60 Skott</p>	<table style="width:100%; border-collapse: collapse;"> <tr><td>11:</td><td>10.3x</td><td>↖</td></tr> <tr><td>12:</td><td>10.5x</td><td>↑</td></tr> <tr><td>13:</td><td>10.4x</td><td>↖</td></tr> <tr><td>14:</td><td>10.2x</td><td>↓</td></tr> <tr><td>15:</td><td>10.4x</td><td>→</td></tr> <tr><td>16:</td><td>10.5x</td><td>↗</td></tr> <tr><td>17:</td><td>10.7x</td><td>↘</td></tr> <tr><td>18:</td><td>10.5x</td><td>↘</td></tr> <tr><td>19:</td><td>10.4x</td><td>←</td></tr> <tr><td>20:</td><td>10.4x</td><td>↗</td></tr> <tr><td colspan="2">Serie</td><td style="text-align: right;">100.0</td></tr> <tr><td colspan="2">Total</td><td style="text-align: right;">199.0</td></tr> </table>	11:	10.3x	↖	12:	10.5x	↑	13:	10.4x	↖	14:	10.2x	↓	15:	10.4x	→	16:	10.5x	↗	17:	10.7x	↘	18:	10.5x	↘	19:	10.4x	←	20:	10.4x	↗	Serie		100.0	Total		199.0	<p>60 Skott</p>	<table style="width:100%; border-collapse: collapse;"> <tr><td>21:</td><td>10.8x</td><td>↗</td></tr> <tr><td>22:</td><td>10.1</td><td>↑</td></tr> <tr><td>23:</td><td>10.7x</td><td>↑</td></tr> <tr><td>24:</td><td>10.7x</td><td>↗</td></tr> <tr><td>25:</td><td>10.3x</td><td>↑</td></tr> <tr><td>26:</td><td>10.4x</td><td>↖</td></tr> <tr><td>27:</td><td>10.5x</td><td>→</td></tr> <tr><td>28:</td><td>9.8</td><td>↘</td></tr> <tr><td>29:</td><td>10.5x</td><td>↗</td></tr> <tr><td>30:</td><td>10.7x</td><td>↘</td></tr> <tr><td colspan="2">Serie</td><td style="text-align: right;">99.0</td></tr> <tr><td colspan="2">Total</td><td style="text-align: right;">298.0</td></tr> </table>	21:	10.8x	↗	22:	10.1	↑	23:	10.7x	↑	24:	10.7x	↗	25:	10.3x	↑	26:	10.4x	↖	27:	10.5x	→	28:	9.8	↘	29:	10.5x	↗	30:	10.7x	↘	Serie		99.0	Total		298.0
11:	10.3x	↖																																																																									
12:	10.5x	↑																																																																									
13:	10.4x	↖																																																																									
14:	10.2x	↓																																																																									
15:	10.4x	→																																																																									
16:	10.5x	↗																																																																									
17:	10.7x	↘																																																																									
18:	10.5x	↘																																																																									
19:	10.4x	←																																																																									
20:	10.4x	↗																																																																									
Serie		100.0																																																																									
Total		199.0																																																																									
21:	10.8x	↗																																																																									
22:	10.1	↑																																																																									
23:	10.7x	↑																																																																									
24:	10.7x	↗																																																																									
25:	10.3x	↑																																																																									
26:	10.4x	↖																																																																									
27:	10.5x	→																																																																									
28:	9.8	↘																																																																									
29:	10.5x	↗																																																																									
30:	10.7x	↘																																																																									
Serie		99.0																																																																									
Total		298.0																																																																									

<p>60 Skott</p>	<table style="width:100%; border-collapse: collapse;"> <tr><td>31:</td><td>9.8</td><td>→</td></tr> <tr><td>32:</td><td>9.6</td><td>←</td></tr> <tr><td>33:</td><td>10.5x</td><td>↘</td></tr> <tr><td>34:</td><td>10.4x</td><td>↘</td></tr> <tr><td>35:</td><td>10.5x</td><td>↓</td></tr> <tr><td>36:</td><td>10.6x</td><td>↘</td></tr> <tr><td>37:</td><td>10.2x</td><td>←</td></tr> <tr><td>38:</td><td>10.3x</td><td>↘</td></tr> <tr><td>39:</td><td>10.5x</td><td>→</td></tr> <tr><td>40:</td><td>10.2x</td><td>↗</td></tr> <tr><td colspan="2">Serie</td><td style="text-align: right;">98.0</td></tr> <tr><td colspan="2">Total</td><td style="text-align: right;">396.0</td></tr> </table>	31:	9.8	→	32:	9.6	←	33:	10.5x	↘	34:	10.4x	↘	35:	10.5x	↓	36:	10.6x	↘	37:	10.2x	←	38:	10.3x	↘	39:	10.5x	→	40:	10.2x	↗	Serie		98.0	Total		396.0		
31:	9.8	→																																					
32:	9.6	←																																					
33:	10.5x	↘																																					
34:	10.4x	↘																																					
35:	10.5x	↓																																					
36:	10.6x	↘																																					
37:	10.2x	←																																					
38:	10.3x	↘																																					
39:	10.5x	→																																					
40:	10.2x	↗																																					
Serie		98.0																																					
Total		396.0																																					

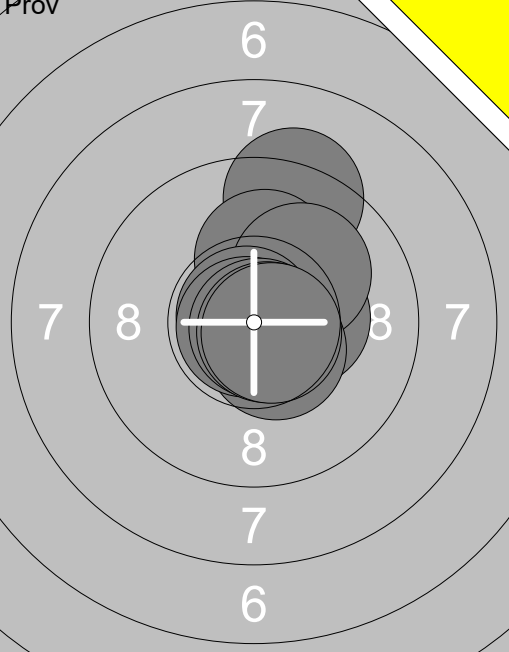
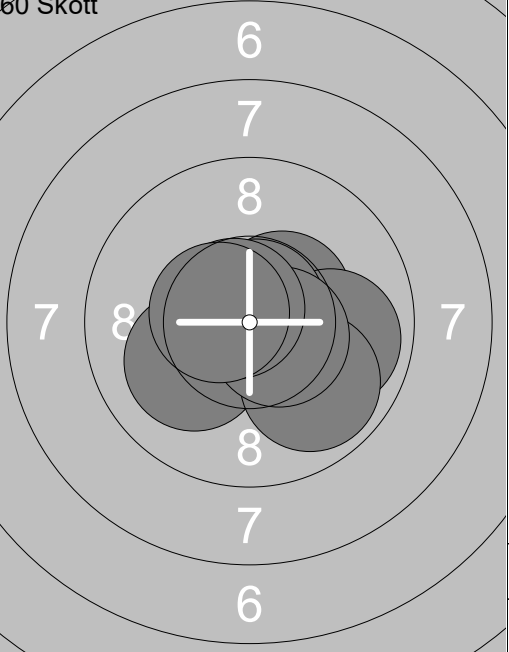
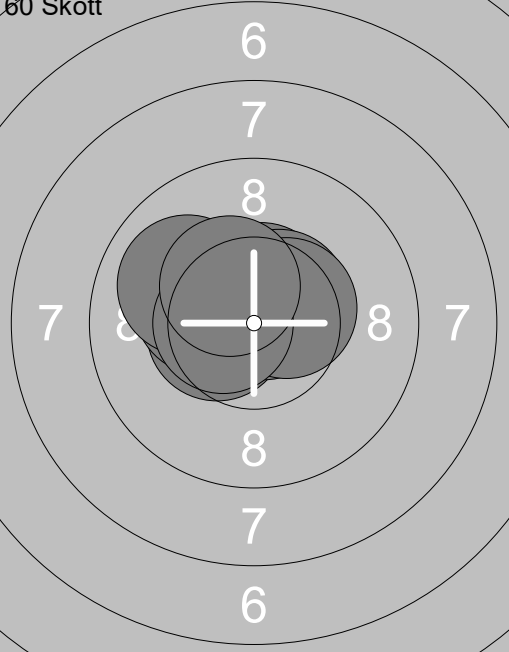
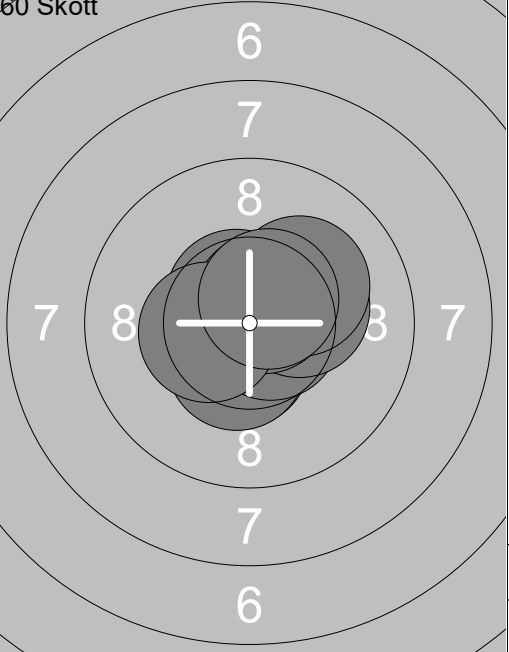
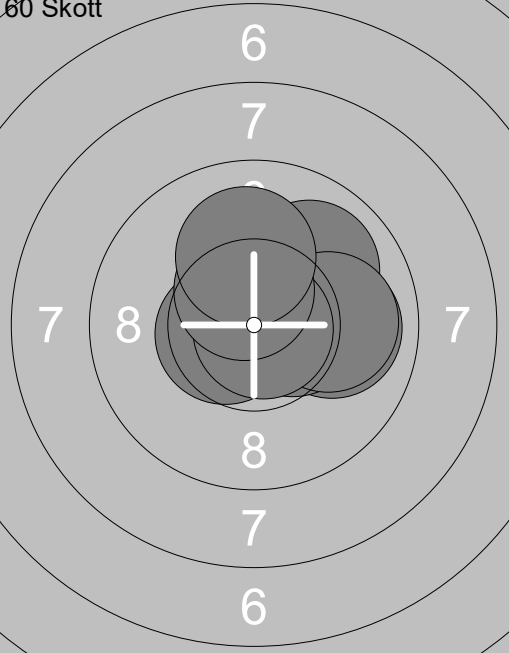
Skjutlag	Tavla	Felicia Perkiö			
1	21	Ramselefors	Umeå	11	Vb
05.11.2023	Vindelskyttet 2023	Ramselefors SKF			
Prov		1: 9.3 ↑ 2: 10.4x→ 3: 10.1 ↑ 4: 10.1 ↗ 5: 10.5x↘ 6: 10.8x↘ 7: 10.8x↘ 8: 10.9x↘ 9: 10.7x↘ 10: 10.7x↘	60 Skott		1: 10.5x↗ 2: 10.8x↘ 3: 9.9 → 4: 10.4x↘ 5: 10.8x↗ 6: 10.1 ↙ 7: 9.9 ↘ 8: 10.5x↘ 9: 10.7x↘ 10: 10.5x↘
		Serie 99.0 Total 0.0			Serie 98.0 Total 98.0
60 Skott		11: 10.5x↘ 12: 10.6x↗ 13: 10.6x↗ 14: 10.3x↘ 15: 10.0 ↙ 16: 10.7x↗ 17: 10.5x↗ 18: 10.5x↗ 19: 10.6x↘ 20: 10.4x↘	60 Skott		21: 10.6x↘ 22: 10.7x→ 23: 10.5x↘ 24: 10.5x↘ 25: 10.7x→ 26: 10.3x→ 27: 10.6x↗ 28: 10.4x↘ 29: 10.2x↗ 30: 10.6x↗
		Serie 100.0 Total 198.0			Serie 100.0 Total 298.0
60 Skott		31: 10.2x↗ 32: 10.6x↘ 33: 10.5x→ 34: 10.0 ↗ 35: 10.0 → 36: 10.5x→ 37: 10.0 → 38: 10.8x↘ 39: 10.5x↗ 40: 10.1 ↑			
		Serie 100.0 Total 398.0			

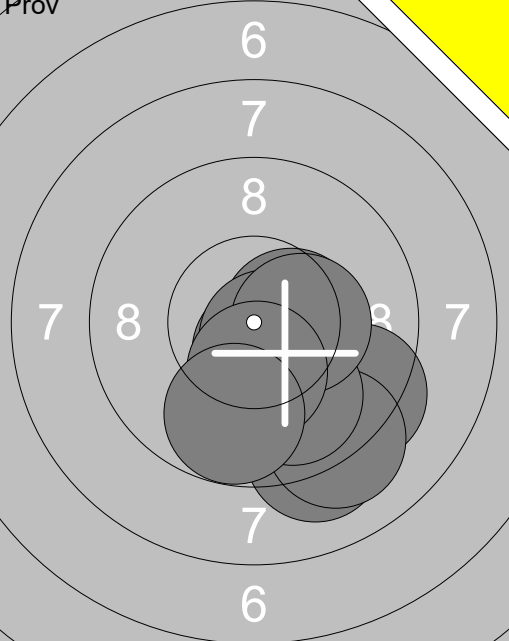
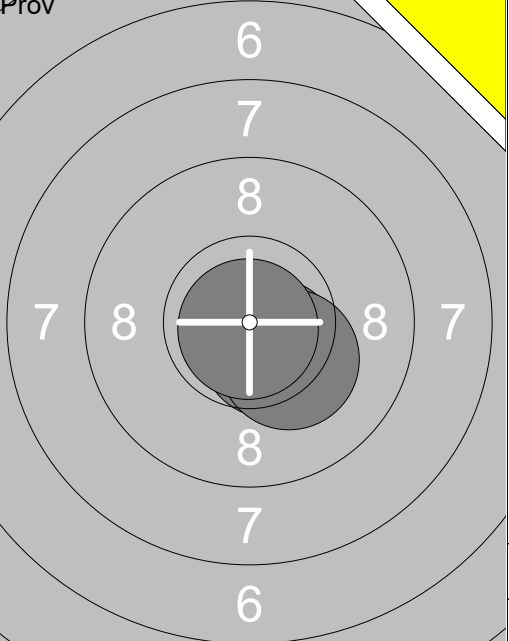
Prov 	1: 9.4 ↘ 2: 9.1 ↓ 3: 9.2 ↓ 4: 10.6x↓ 5: 9.9 ↓ 6: 10.5x→ 7: 10.7x↘ 8: 10.3x→ 9: 10.3x↓ 10: 9.8 ↓ <hr/> Serie 95.0 Total 0.0	Prov 	11: 10.5x↘ 12: 10.3x↘ 13: 10.9x↓ <hr/> Serie 30.0 Total 0.0
--	---	--	---

60 Skott 	1: 10.2x↘ 2: 10.3x↗ 3: 10.3x↘ 4: 10.3x↓ 5: 10.2x↓ 6: 10.6x↘ 7: 10.2x↓ 8: 10.6x↘ 9: 10.5x↘ 10: 10.4x→ <hr/> Serie 100.0 Total 100.0	60 Skott 	11: 10.8x→ 12: 10.7x↘ 13: 10.7x→ 14: 10.2x↘ 15: 9.9 ↓ 16: 10.4x↓ 17: 10.5x↘ 18: 10.6x↓ 19: 10.4x↘ 20: 10.7x↘ <hr/> Serie 99.0 Total 199.0
---	---	---	--

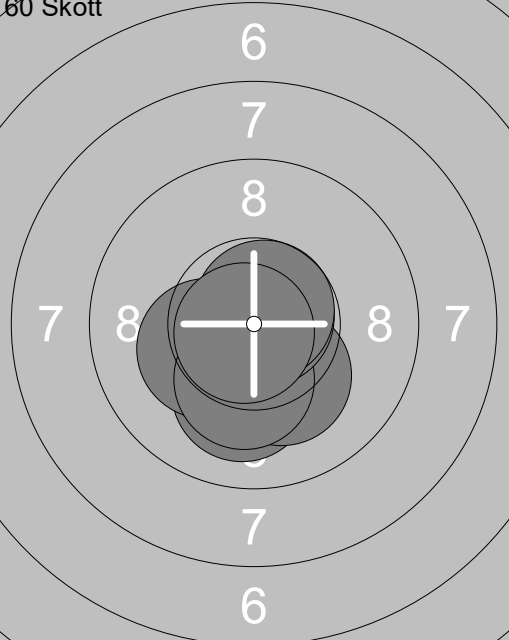
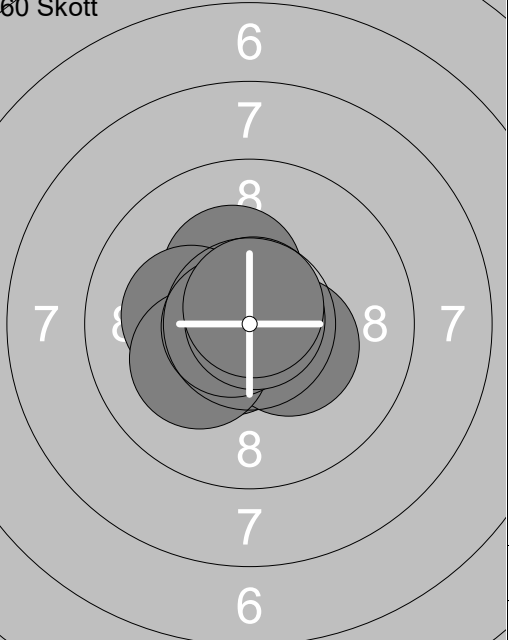
60 Skott 	21: 10.7x↓ 22: 10.1 ↓ 23: 10.5x↘ 24: 10.5x↘ 25: 10.3x↘ 26: 10.2x↘ 27: 10.2x↓ 28: 10.8x↗ 29: 10.7x↗ 30: 10.8x↘ <hr/> Serie 100.0 Total 299.0	60 Skott 	31: 10.6x↘ 32: 10.4x↘ 33: 10.6x↘ 34: 10.5x↘ 35: 10.3x↗ 36: 10.2x↘ 37: 10.2x↘ 38: 10.7x↘ 39: 10.9x↗ 40: 10.7x↗ <hr/> Serie 100.0 Total 399.0
--	--	--	--

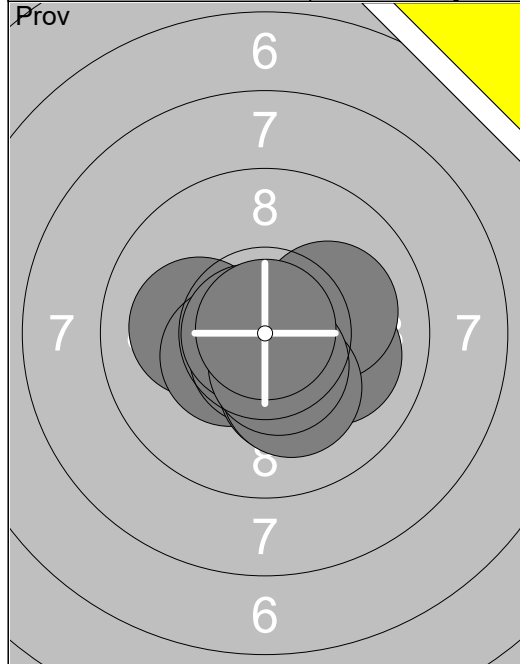

1:	10.1 →
2:	10.1 ←
3:	10.4 ↘
4:	10.7 ↘
5:	10.8 ←
6:	10.2 ↘
7:	10.1 →
8:	10.2 ↘
9:	10.5 ↘
10:	10.9 ↗
Serie	100.0
Total	0.0

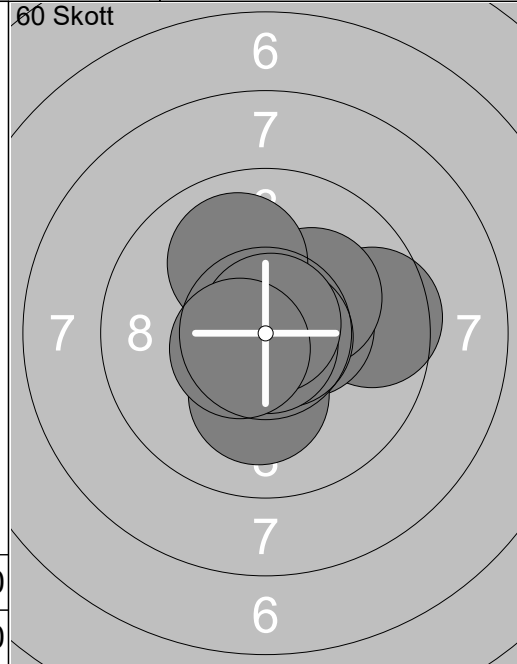

1:	9.6 →
2:	10.5x →
3:	10.2x ↗
4:	10.8x ↘
5:	10.0 ↖
6:	10.2x ↘
7:	10.7x →
8:	10.8x ↘
9:	10.8x ↗
10:	10.6x ↘
Serie	99.0
Total	99.0

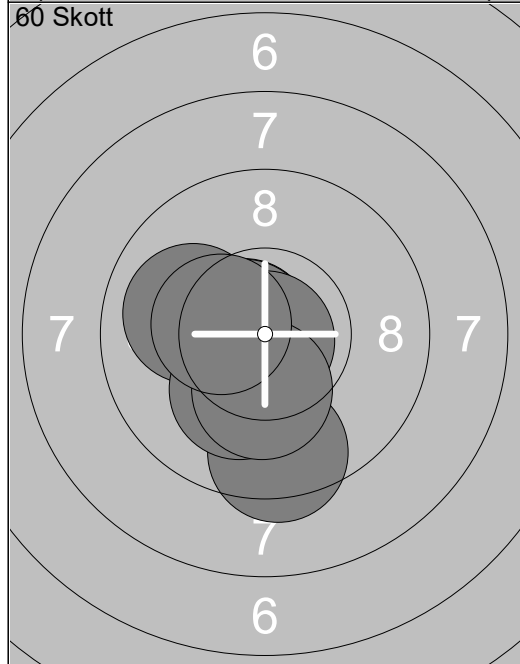

11:	10.5x ↘
12:	10.7x ↘
13:	10.5x ↘
14:	10.7x ↘
15:	9.4 ↓
16:	10.0 ←
17:	10.2x ↘
18:	10.9x ↘
19:	10.2x ↘
20:	10.4x ↘
Serie	99.0
Total	198.0

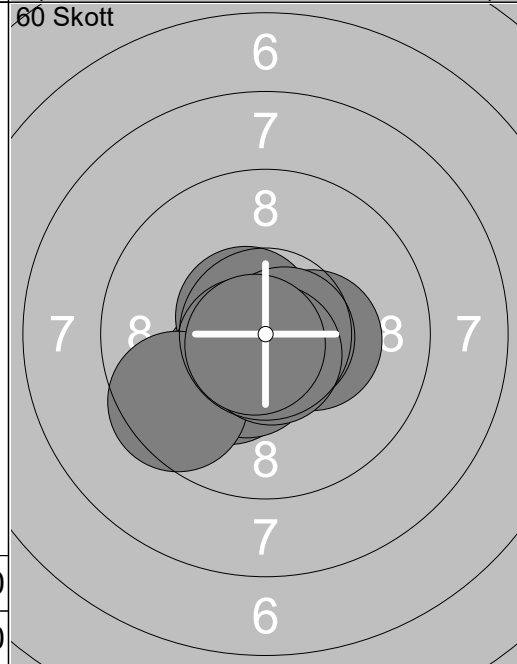

21:	10.7x ↘
22:	10.3x ↘
23:	10.5x ↘
24:	10.6x ↘
25:	10.4x →
26:	10.7x →
27:	10.6x ↘
28:	9.5 ↙
29:	10.7x ↘
30:	10.8x ↘
Serie	99.0
Total	297.0

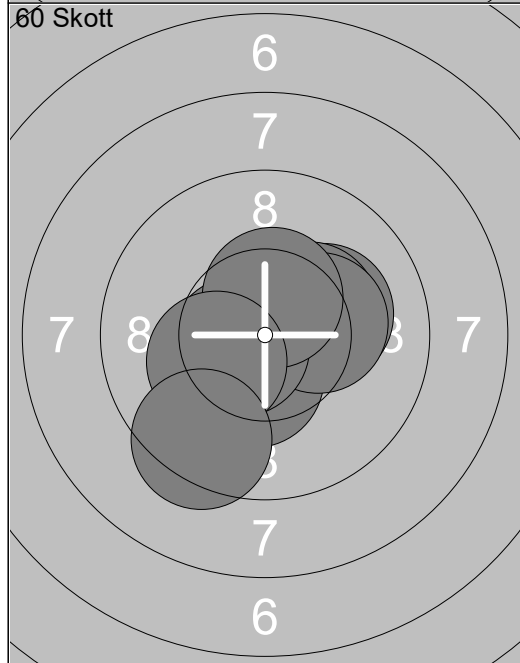

31:	10.5x ↘
32:	10.4x ↘
33:	10.2x →
34:	10.6x ↗
35:	10.3x →
36:	10.3x →
37:	10.6x ↘
38:	10.5x ↗
39:	10.2x ↘
40:	9.4 ↙
Serie	99.0
Total	396.0

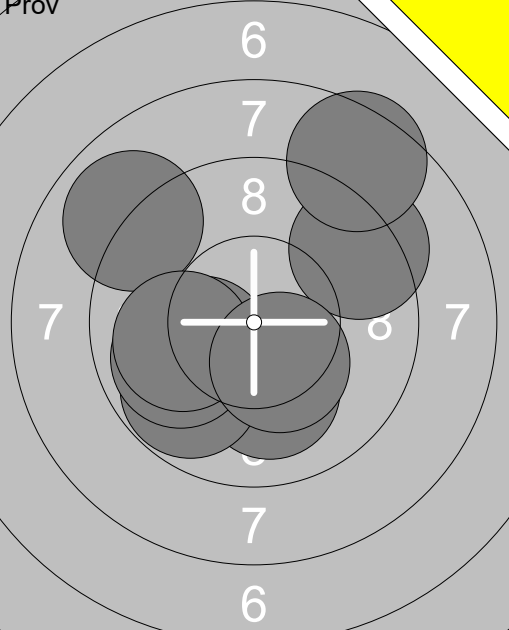
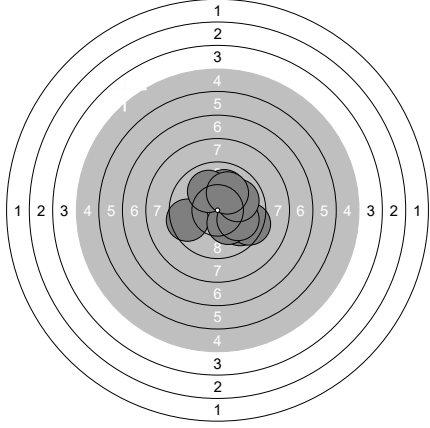
<p>Prov</p> 	<p>60 Skott</p> 	<table style="width:100%; border-collapse: collapse;"> <tr><td>1:</td><td>10.1</td><td>↓</td></tr> <tr><td>2:</td><td>10.2</td><td>↘</td></tr> <tr><td>3:</td><td>8.9</td><td>↖</td></tr> <tr><td>4:</td><td>9.8</td><td>↓</td></tr> <tr><td>5:</td><td>9.9</td><td>←</td></tr> <tr><td>6:</td><td>9.3</td><td>↗</td></tr> <tr><td>7:</td><td>8.5</td><td>↗</td></tr> <tr><td>8:</td><td>10.0</td><td>←</td></tr> <tr><td>9:</td><td>10.3</td><td>↘</td></tr> <tr><td colspan="2">Serie</td><td>83.0</td></tr> <tr><td colspan="2">Total</td><td>0.0</td></tr> </table>	1:	10.1	↓	2:	10.2	↘	3:	8.9	↖	4:	9.8	↓	5:	9.9	←	6:	9.3	↗	7:	8.5	↗	8:	10.0	←	9:	10.3	↘	Serie		83.0	Total		0.0			
1:	10.1	↓																																				
2:	10.2	↘																																				
3:	8.9	↖																																				
4:	9.8	↓																																				
5:	9.9	←																																				
6:	9.3	↗																																				
7:	8.5	↗																																				
8:	10.0	←																																				
9:	10.3	↘																																				
Serie		83.0																																				
Total		0.0																																				
		<table style="width:100%; border-collapse: collapse;"> <tr><td>1:</td><td>9.6</td><td>←</td></tr> <tr><td>2:</td><td>10.0</td><td>↗</td></tr> <tr><td>3:</td><td>0.0</td><td>↖</td></tr> <tr><td>4:</td><td>9.8</td><td>↘</td></tr> <tr><td>5:</td><td>9.4</td><td>↘</td></tr> <tr><td>6:</td><td>10.2</td><td>↘</td></tr> <tr><td>7:</td><td>10.0</td><td>→</td></tr> <tr><td>8:</td><td>10.0</td><td>↗</td></tr> <tr><td>9:</td><td>10.0</td><td>↖</td></tr> <tr><td>10:</td><td>10.1</td><td>↗</td></tr> <tr><td colspan="2">Serie</td><td>87.0</td></tr> <tr><td colspan="2">Total</td><td>87.0</td></tr> </table>	1:	9.6	←	2:	10.0	↗	3:	0.0	↖	4:	9.8	↘	5:	9.4	↘	6:	10.2	↘	7:	10.0	→	8:	10.0	↗	9:	10.0	↖	10:	10.1	↗	Serie		87.0	Total		87.0
1:	9.6	←																																				
2:	10.0	↗																																				
3:	0.0	↖																																				
4:	9.8	↘																																				
5:	9.4	↘																																				
6:	10.2	↘																																				
7:	10.0	→																																				
8:	10.0	↗																																				
9:	10.0	↖																																				
10:	10.1	↗																																				
Serie		87.0																																				
Total		87.0																																				

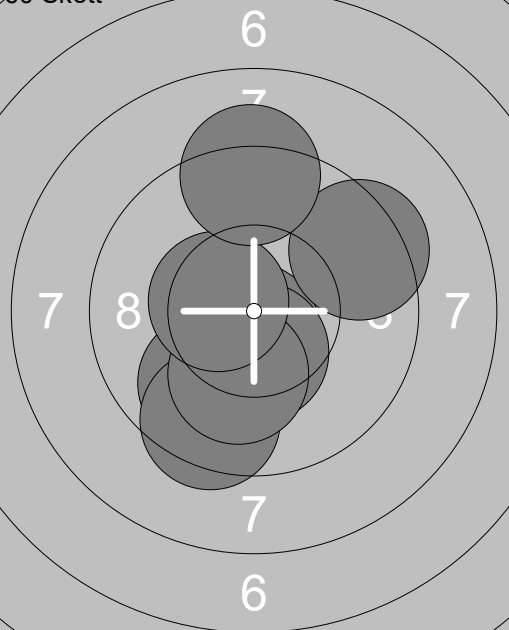
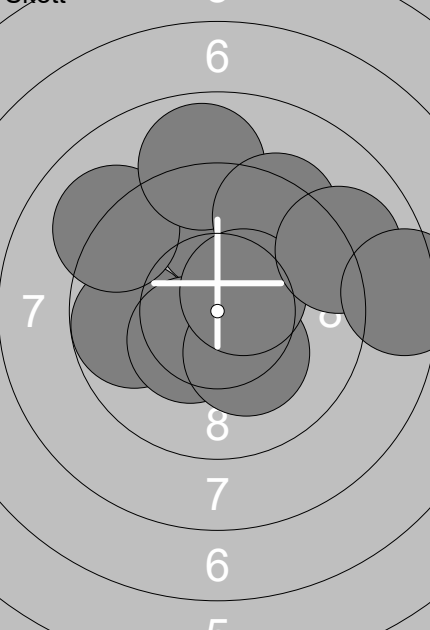
<p>60 Skott</p> 	<p>60 Skott</p> 	<table style="width:100%; border-collapse: collapse;"> <tr><td>11:</td><td>10.4</td><td>↘</td></tr> <tr><td>12:</td><td>10.4</td><td>↘</td></tr> <tr><td>13:</td><td>10.7</td><td>↘</td></tr> <tr><td>14:</td><td>9.9</td><td>↓</td></tr> <tr><td>15:</td><td>10.4</td><td>↘</td></tr> <tr><td>16:</td><td>9.5</td><td>↓</td></tr> <tr><td>17:</td><td>10.1</td><td>↓</td></tr> <tr><td>18:</td><td>10.5</td><td>↘</td></tr> <tr><td>19:</td><td>9.4</td><td>↗</td></tr> <tr><td>20:</td><td>9.2</td><td>↑</td></tr> <tr><td colspan="2">Serie</td><td>96.0</td></tr> <tr><td colspan="2">Total</td><td>183.0</td></tr> </table>	11:	10.4	↘	12:	10.4	↘	13:	10.7	↘	14:	9.9	↓	15:	10.4	↘	16:	9.5	↓	17:	10.1	↓	18:	10.5	↘	19:	9.4	↗	20:	9.2	↑	Serie		96.0	Total		183.0
11:	10.4	↘																																				
12:	10.4	↘																																				
13:	10.7	↘																																				
14:	9.9	↓																																				
15:	10.4	↘																																				
16:	9.5	↓																																				
17:	10.1	↓																																				
18:	10.5	↘																																				
19:	9.4	↗																																				
20:	9.2	↑																																				
Serie		96.0																																				
Total		183.0																																				
		<table style="width:100%; border-collapse: collapse;"> <tr><td>21:</td><td>9.8</td><td>←</td></tr> <tr><td>22:</td><td>9.8</td><td>↑</td></tr> <tr><td>23:</td><td>10.4</td><td>↘</td></tr> <tr><td>24:</td><td>9.1</td><td>↖</td></tr> <tr><td>25:</td><td>8.9</td><td>↑</td></tr> <tr><td>26:</td><td>9.4</td><td>↗</td></tr> <tr><td>27:</td><td>10.2</td><td>↘</td></tr> <tr><td>28:</td><td>10.5</td><td>↗</td></tr> <tr><td>29:</td><td>9.0</td><td>↗</td></tr> <tr><td>30:</td><td>8.3</td><td>→</td></tr> <tr><td colspan="2">Serie</td><td>91.0</td></tr> <tr><td colspan="2">Total</td><td>274.0</td></tr> </table>	21:	9.8	←	22:	9.8	↑	23:	10.4	↘	24:	9.1	↖	25:	8.9	↑	26:	9.4	↗	27:	10.2	↘	28:	10.5	↗	29:	9.0	↗	30:	8.3	→	Serie		91.0	Total		274.0
21:	9.8	←																																				
22:	9.8	↑																																				
23:	10.4	↘																																				
24:	9.1	↖																																				
25:	8.9	↑																																				
26:	9.4	↗																																				
27:	10.2	↘																																				
28:	10.5	↗																																				
29:	9.0	↗																																				
30:	8.3	→																																				
Serie		91.0																																				
Total		274.0																																				

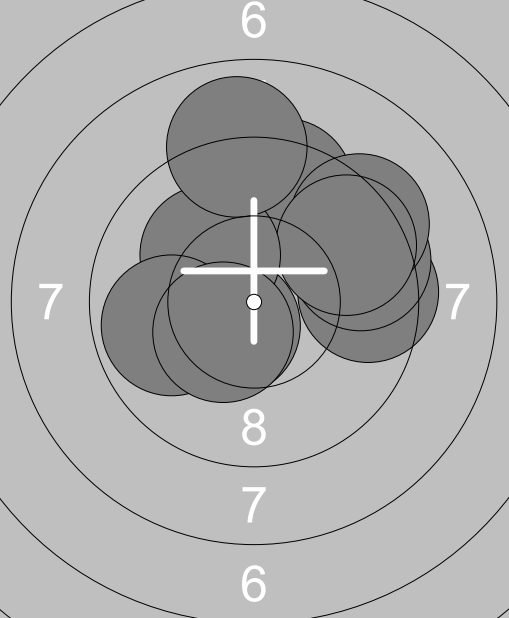
<p>60 Skott</p> 	<table style="width:100%; border-collapse: collapse;"> <tr><td>31:</td><td>9.5</td><td>↑</td></tr> <tr><td>32:</td><td>10.5</td><td>↘</td></tr> <tr><td>33:</td><td>9.5</td><td>→</td></tr> <tr><td>34:</td><td>9.5</td><td>→</td></tr> <tr><td>35:</td><td>9.3</td><td>↗</td></tr> <tr><td>36:</td><td>9.6</td><td>↗</td></tr> <tr><td>37:</td><td>10.1</td><td>↖</td></tr> <tr><td>38:</td><td>9.0</td><td>↑</td></tr> <tr><td>39:</td><td>9.9</td><td>←</td></tr> <tr><td>40:</td><td>10.4</td><td>↘</td></tr> <tr><td colspan="2">Serie</td><td>93.0</td></tr> <tr><td colspan="2">Total</td><td>367.0</td></tr> </table>	31:	9.5	↑	32:	10.5	↘	33:	9.5	→	34:	9.5	→	35:	9.3	↗	36:	9.6	↗	37:	10.1	↖	38:	9.0	↑	39:	9.9	←	40:	10.4	↘	Serie		93.0	Total		367.0	
31:	9.5	↑																																				
32:	10.5	↘																																				
33:	9.5	→																																				
34:	9.5	→																																				
35:	9.3	↗																																				
36:	9.6	↗																																				
37:	10.1	↖																																				
38:	9.0	↑																																				
39:	9.9	←																																				
40:	10.4	↘																																				
Serie		93.0																																				
Total		367.0																																				

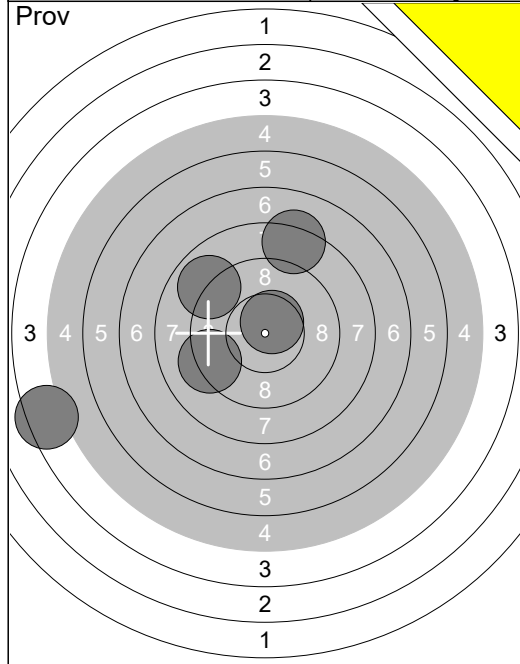

1:	4.4	←
2:	8.9	↖
3:	8.3	↑
4:	10.6	↗
5:	9.2	←
Serie	39.0	
Total	0.0	

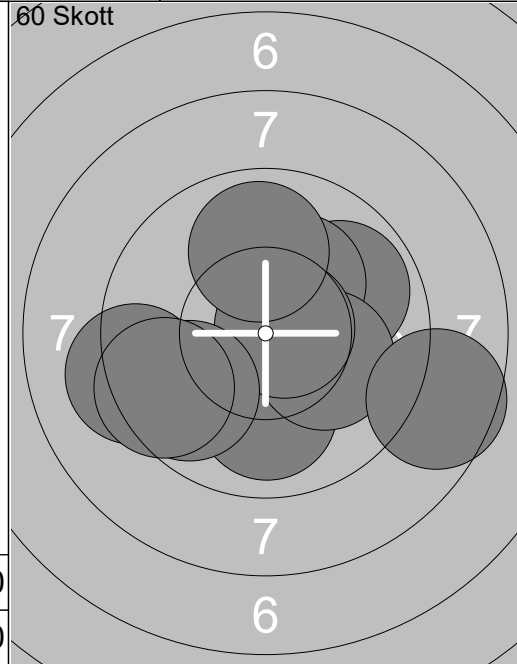

1:	10.0	↓
2:	9.9	↗
3:	10.2	↗
4:	10.1	→
5:	9.2	←
6:	10.7	↗
7:	9.7	←
8:	9.9	↑
9:	9.5	←
10:	8.6	→
Serie	93.0	
Total	93.0	

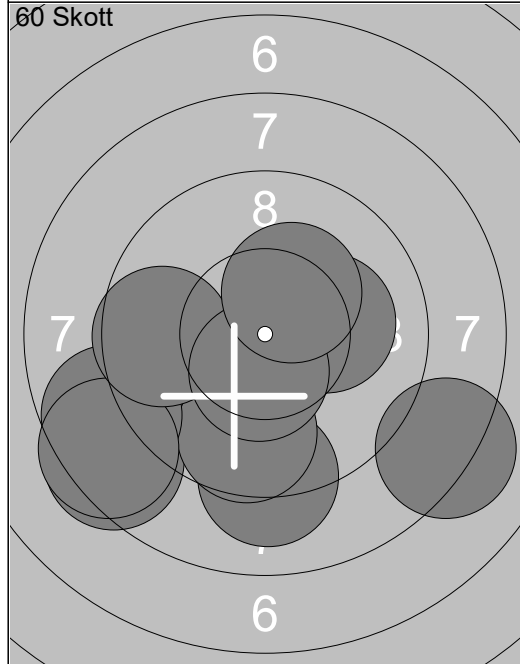

11:	8.2	→
12:	8.4	←
13:	10.2	↗
14:	9.1	↓
15:	9.7	↓
16:	8.7	←
17:	8.5	←
18:	9.6	←
19:	10.5	↘
20:	10.3	↗
Serie	89.0	
Total	182.0	

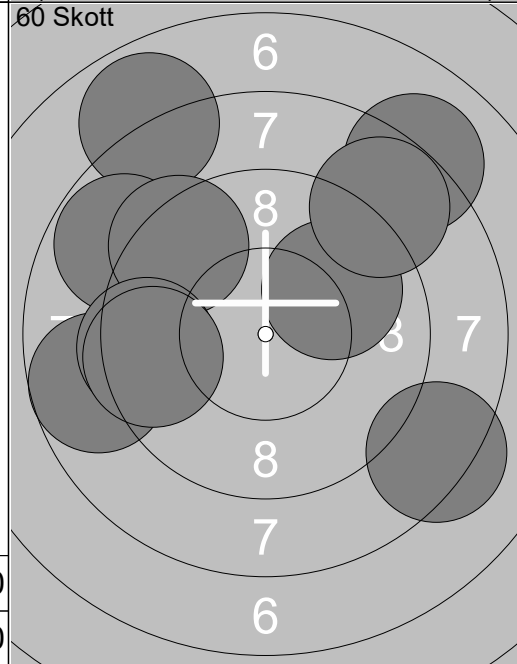

21:	8.3	↘
22:	7.9	↖
23:	8.8	↖
24:	9.4	↖
25:	8.7	←
26:	9.4	←
27:	9.5	←
28:	8.1	↗
29:	9.9	↗
30:	8.8	↗
Serie	83.0	
Total	265.0	

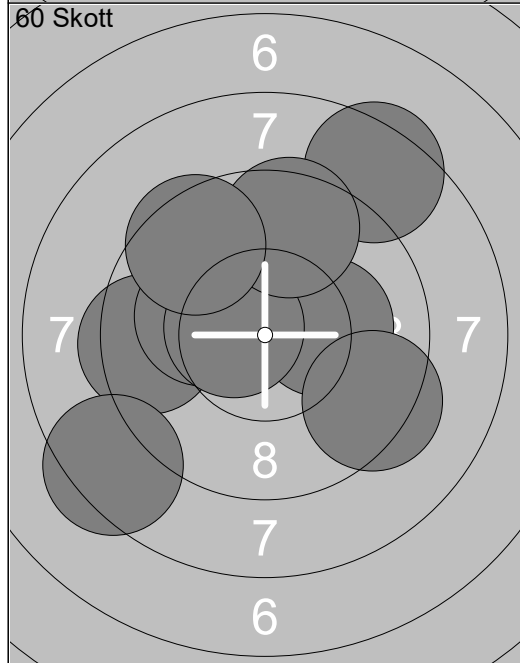

31:	9.4	←
32:	10.5	↗
33:	10.2	↗
34:	9.3	↘
35:	10.1	←
36:	10.5	↖
37:	8.5	↗
38:	9.5	↑
39:	9.5	↖
40:	8.4	←
Serie	92.0	
Total	357.0	

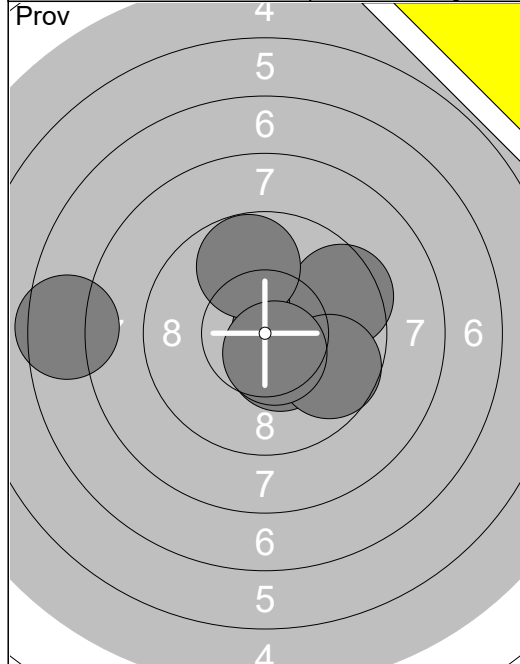

1: 10.6x➤
2: 9.5 ➤
3: 10.4x↘
4: 7.5 ←
5: 9.7 ➤
6: 9.8 ↑
7: 10.6x↘
Serie 64.0
Total 0.0

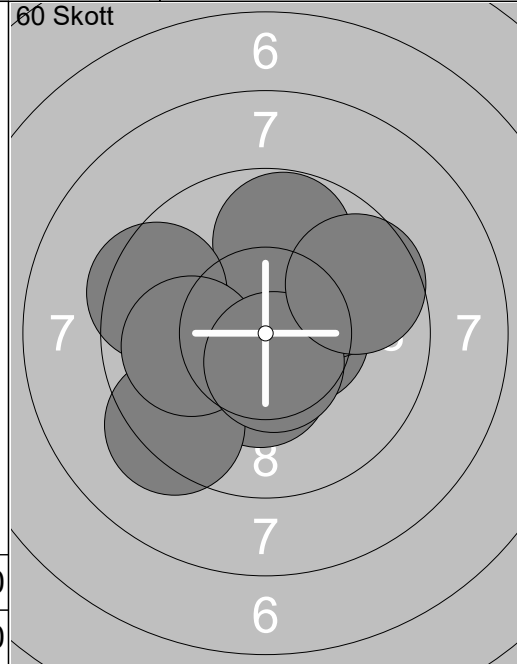

1: 10.4x↘
2: 10.4x↗
3: 10.5x➤
4: 10.0 ➤
5: 9.3 ↙
6: 9.8 ↑
7: 9.5 ←
8: 10.0←
9: 10.6x↘
10: 9.6 ➤
Serie 96.0
Total 96.0

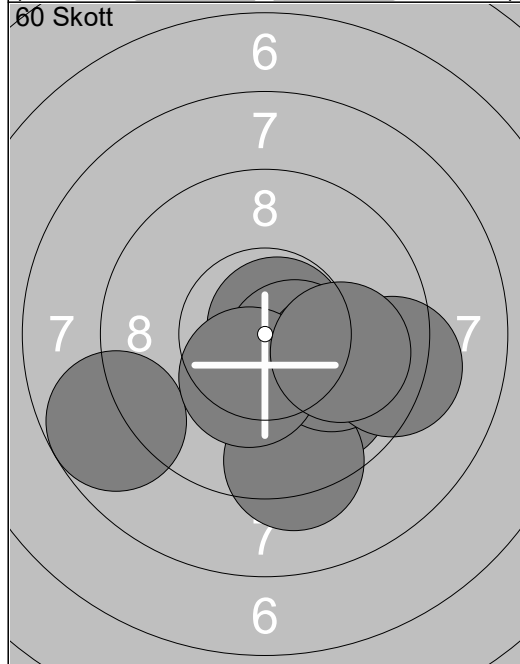

11: 10.8x↘
12: 10.8x➤
13: 9.9 ↘
14: 9.3 ↓
15: 8.8 ←
16: 10.5x↘
17: 10.0 ➤
18: 10.4x↘
19: 9.3 ➤
20: 10.0 ➤
Serie 95.0
Total 191.0

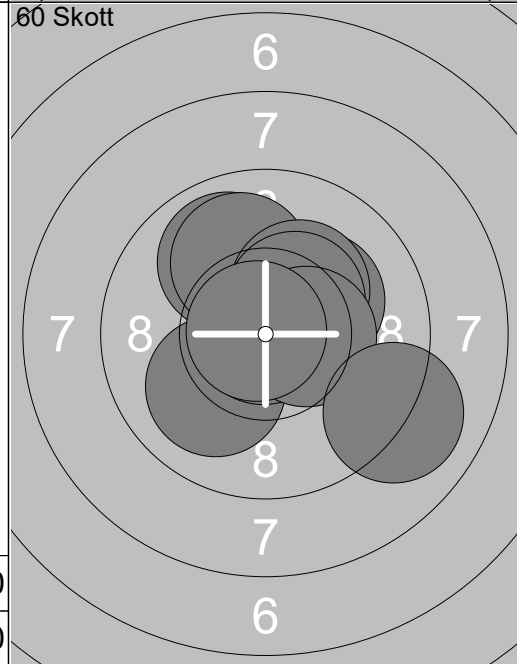

21: 10.2x↗
22: 10.0 ↙
23: 10.9x↔
24: 9.9 ↖
25: 10.0 ↑
26: 10.2x↗
27: 10.4x↗
28: 10.4x➤
29: 10.8x↔
30: 9.0 ↘
Serie 98.0
Total 289.0

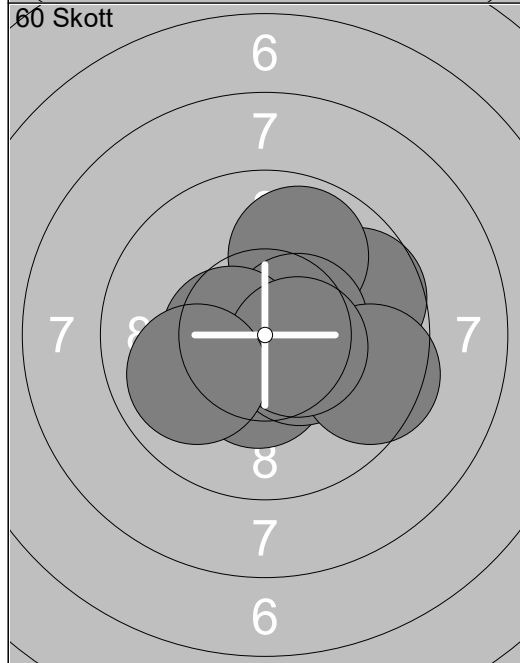

31: 9.7 ➤
32: 10.7x↘
33: 9.9 ↑
34: 10.4x↘
35: 10.5x➤
36: 10.5x↔
37: 10.4x↘
38: 9.5 ➤
39: 10.5x➤
40: 9.9 ↙
Serie 96.0
Total 385.0

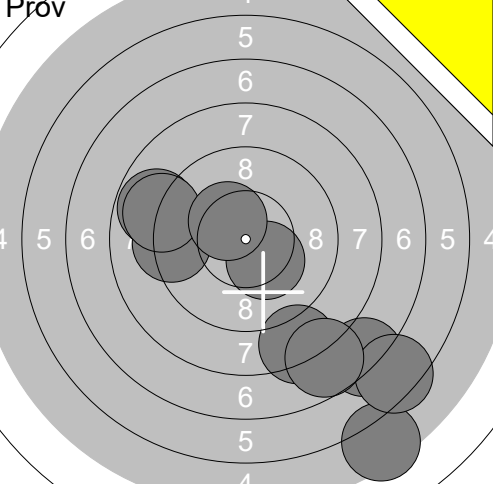
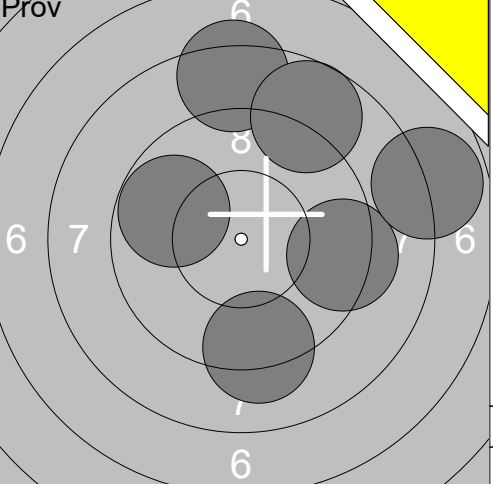
<p>Pröv</p> 	<p>1: 8.8 ↖ 2: 5.4 ↘ 3: 9.3 ← 4: 10.3x ↘ 5: 7.1 ↘ 6: 6.4 ↘ 7: 8.3 ↘ 8: 7.7 ↘ 9: 8.9 ↖ 10: 10.4x ↗</p> <p>Serie 82.6 Total 0.0</p>	<p>Pröv</p> 	<p>11: 9.3 → 12: 9.2 ↓ 13: 8.3 ↑ 14: 9.8 ← 15: 8.7 ↗ 16: 7.8 →</p> <p>Serie 53.1 Total 0.0</p>
---	--	---	---

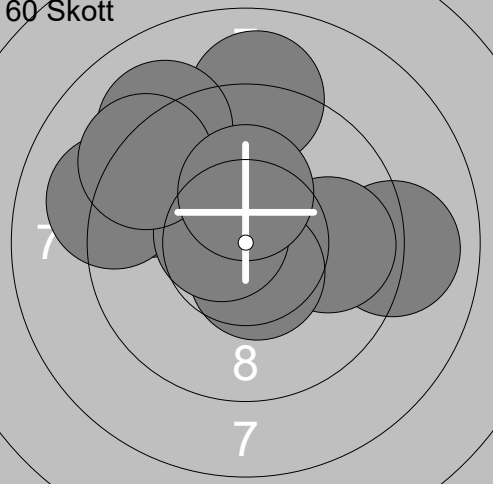
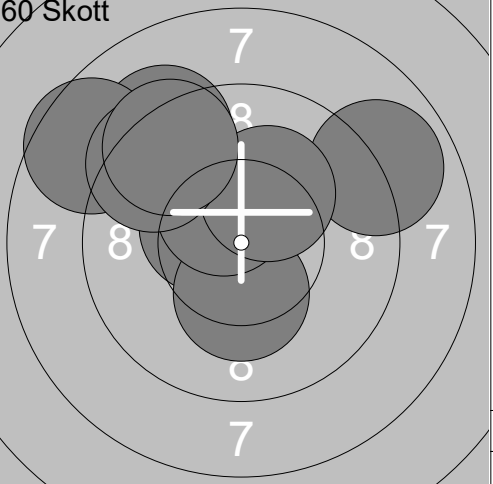
<p>60 Skott</p> 	<p>1: 9.4 ↖ 2: 9.0 ↑ 3: 9.1 ↗ 4: 9.0 → 5: 9.9 → 6: 10.5x ↘ 7: 9.1 ↖ 8: 10.6x ↖ 9: 9.3 ↗ 10: 10.3x ↑</p> <p>Serie 96.2 Total 96.2</p>	<p>60 Skott</p> 	<p>11: 9.2 ↖ 12: 8.6 ↖ 13: 10.8x ↖ 14: 10.4x ← 15: 8.9 ↗ 16: 10.3x ↓ 17: 10.4x ↗ 18: 10.2x ↗ 19: 9.4 ↖ 20: 9.4 ↖</p> <p>Serie 97.6 Total 193.8</p>
--	---	--	---

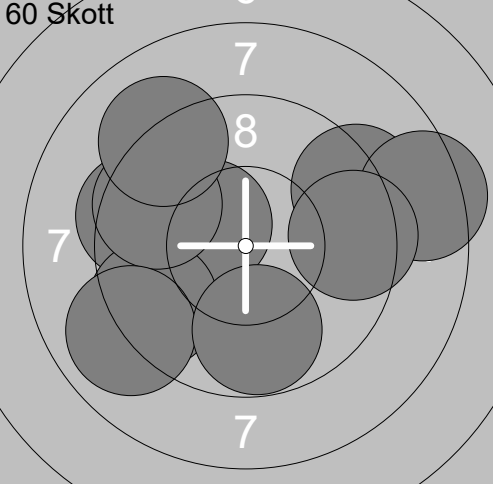
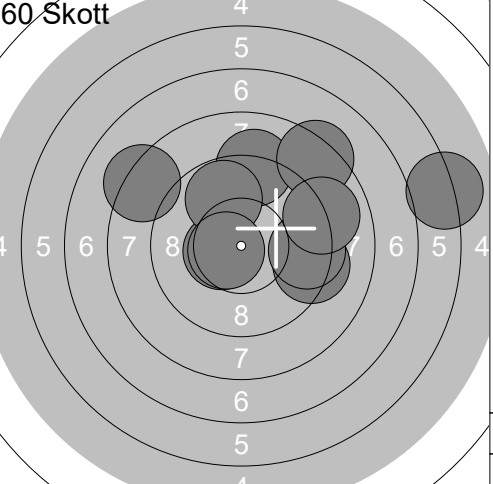
<p>60 Skott</p> 	<p>21: 10.3x ↖ 22: 9.2 → 23: 8.4 → 24: 9.4 ← 25: 9.4 → 26: 9.4 ← 27: 9.6 ↖ 28: 9.1 ↗ 29: 9.0 ↘ 30: 9.8 ↓</p> <p>Serie 93.6 Total 287.4</p>	<p>60 Skott</p> 	<p>31: 9.3 → 32: 9.1 ↑ 33: 10.5x ← 34: 8.2 ↖ 35: 9.8 ↗ 36: 10.6x ← 37: 9.4 → 38: 6.1 → 39: 8.3 ↗ 40: 9.0 →</p> <p>Serie 90.3 Total 377.7</p>
---	---	---	---

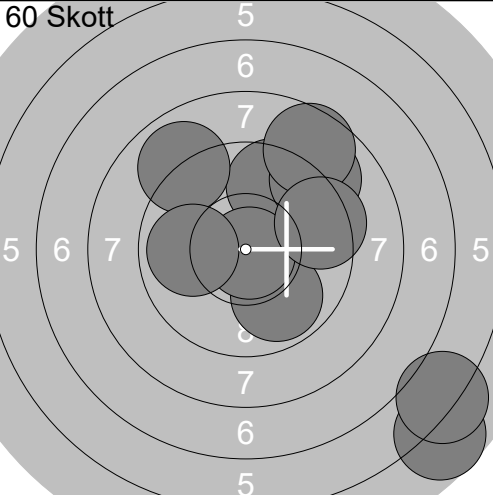
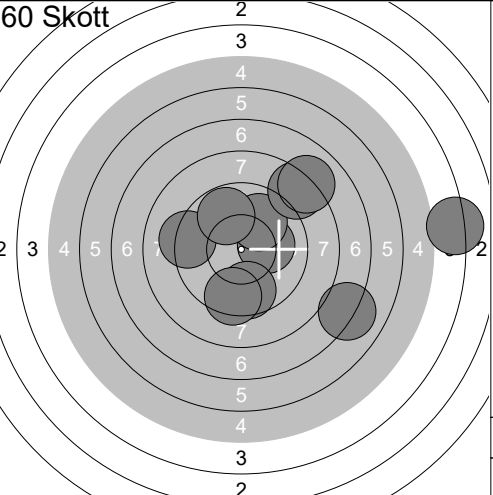
<p>60 Skott</p> 	<p>41: 9.6 ↗ 42: 9.9 ↘ 43: 5.7 ↘ 44: 6.1 ↘ 45: 8.9 ↗ 46: 9.0 ↗ 47: 8.6 ↗ 48: 10.8x ↘ 49: 9.9 ← 50: 9.4 →</p> <p>Serie 87.9 Total 465.6</p>	<p>60 Skott</p> 	<p>51: 10.2x → 52: 4.2 → 53: 9.9 ↗ 54: 7.1 ↘ 55: 9.2 ← 56: 8.4 ↗ 57: 9.6 ↓ 58: 9.5 ↓ 59: 9.8 ↗ 60: 8.1 ↗</p> <p>Serie 86.0 Total 551.6</p>
---	---	---	---

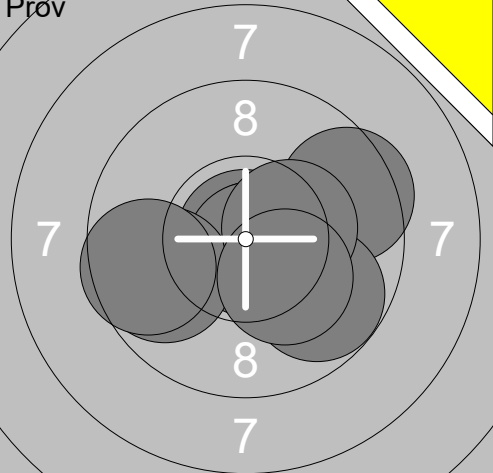
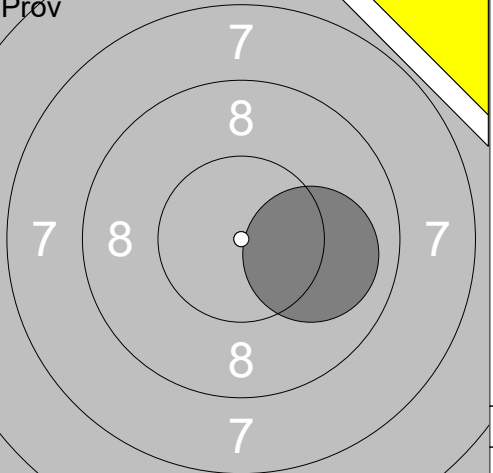
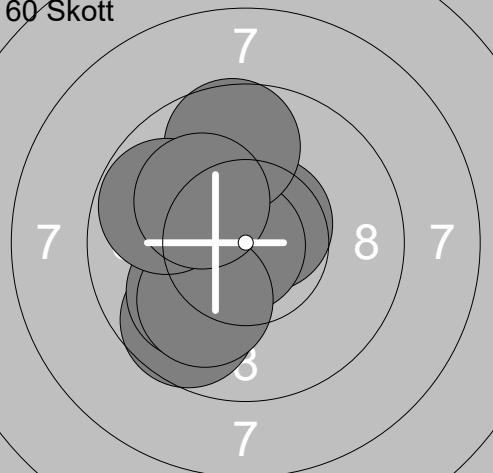
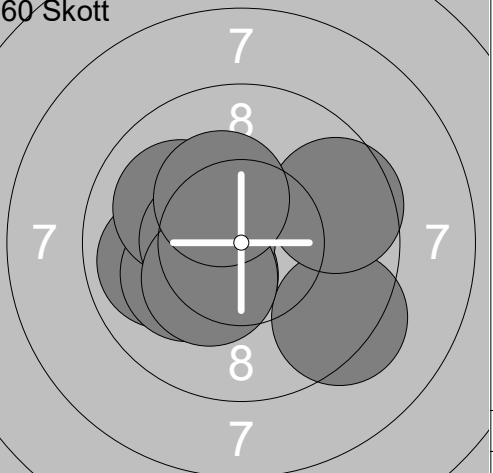
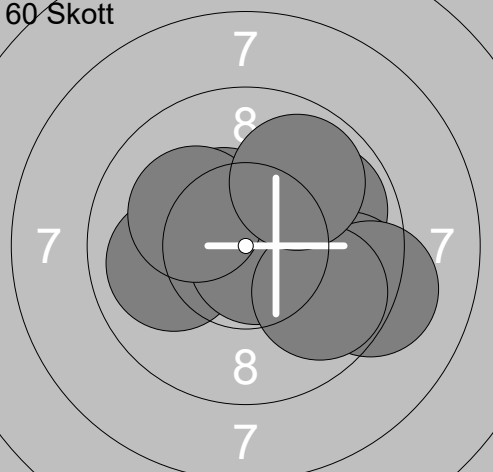
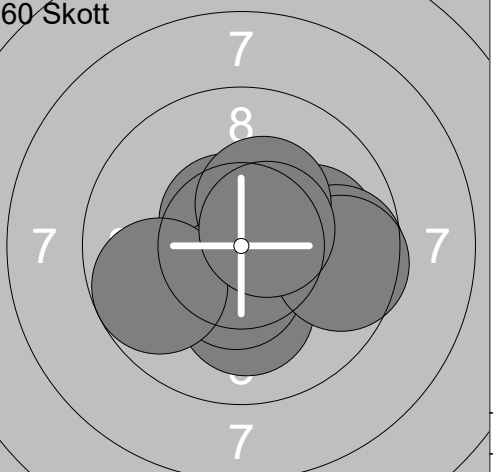
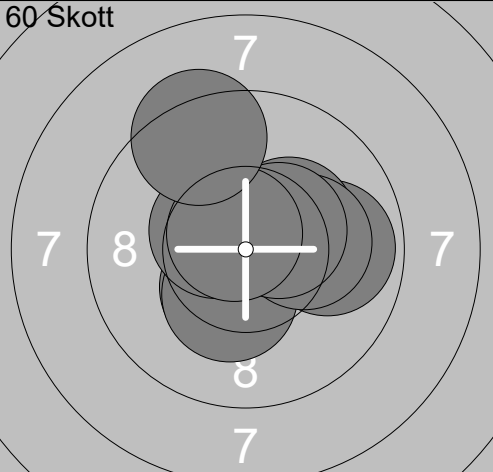
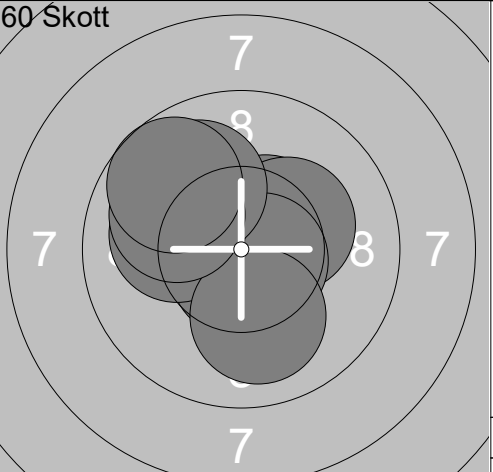
<p>Pröv</p> 	<p>1: 10.0 ↘ 2: 10.9x ↗ 3: 10.8x ↘ 4: 9.5 → 5: 10.8x ↘ 6: 9.8 ↘ 7: 9.8 ↙ 8: 10.4x → 9: 10.2x ↘ 10: 9.6 ←</p> <p>Serie 101.8 Total 0.0</p>	<p>Pröv</p>  <p>11: 10.0 →</p> <p>Serie 10.0 Total 0.0</p>
<p>60 Skott</p> 	<p>1: 10.8x ← 2: 9.7 ↘ 3: 10.0 ↘ 4: 10.6x ↗ 5: 10.5x ← 6: 10.8x ← 7: 10.0 ↘ 8: 9.7 ↑ 9: 9.8 ↙ 10: 10.2x ↗</p> <p>Serie 102.1 Total 102.1</p>	<p>60 Skott</p>  <p>11: 10.4x ↙ 12: 9.3 ↘ 13: 9.9 ← 14: 10.3x ↙ 15: 10.1 ↙ 16: 10.0 ↙ 17: 10.5x ← 18: 9.6 → 19: 10.3x ↘ 20: 10.3x ↗</p> <p>Serie 100.7 Total 202.8</p>
<p>60 Skott</p> 	<p>21: 10.4x → 22: 10.0 ← 23: 10.5x ↗ 24: 9.9 → 25: 9.6 ↘ 26: 10.8x ↘ 27: 9.2 → 28: 10.2x ↗ 29: 9.8 ↘ 30: 9.9 ↗</p> <p>Serie 100.3 Total 303.1</p>	<p>60 Skott</p>  <p>31: 10.1 ↓ 32: 10.0 → 33: 10.6x ↗ 34: 10.4x ↗ 35: 9.7 → 36: 10.5x ↓ 37: 9.6 → 38: 10.3x ↗ 39: 9.8 ← 40: 10.5x ↗</p> <p>Serie 101.5 Total 404.6</p>
<p>60 Skott</p> 	<p>41: 10.4x ↘ 42: 10.3x ↘ 43: 10.6x ↗ 44: 9.9 → 45: 10.5x ↗ 46: 10.3x ↗ 47: 10.2x → 48: 10.4x ↗ 49: 10.7x ↗ 50: 9.3 ↗</p> <p>Serie 102.6 Total 507.2</p>	<p>60 Skott</p>  <p>51: 10.7x ↓ 52: 10.5x ↗ 53: 10.3x ↗ 54: 10.7x ↘ 55: 10.7x ↘ 56: 10.1 ← 57: 10.0 ↗ 58: 10.0 ↓ 59: 10.0 ↙ 60: 9.7 ↗</p> <p>Serie 102.7 Total 609.9</p>

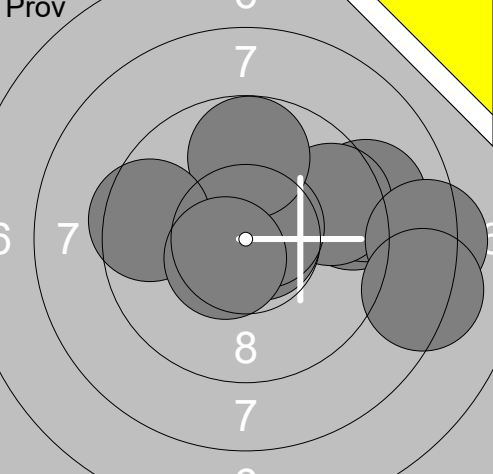
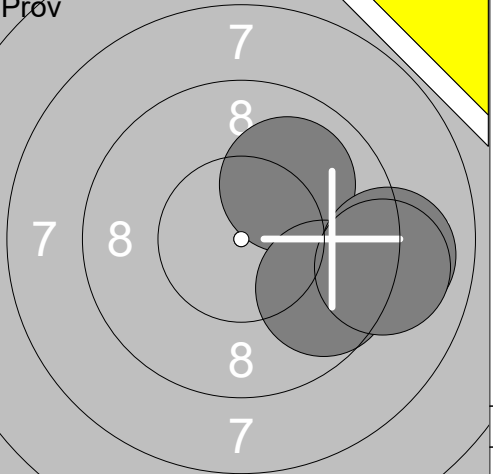
<p>Prov</p> 	<table border="1" style="width:100%; border-collapse: collapse;"> <tr><td>1:</td><td>9.3</td><td>→</td></tr> <tr><td>2:</td><td>9.1</td><td>→</td></tr> <tr><td>3:</td><td>9.6</td><td>→</td></tr> <tr><td>4:</td><td>10.8x</td><td>→</td></tr> <tr><td>5:</td><td>10.6x</td><td>↗</td></tr> <tr><td>6:</td><td>8.3</td><td>→</td></tr> <tr><td>7:</td><td>9.8</td><td>↑</td></tr> <tr><td>8:</td><td>9.5</td><td>←</td></tr> <tr><td>9:</td><td>8.3</td><td>→</td></tr> <tr><td>10:</td><td>10.5x</td><td>↙</td></tr> <tr><td colspan="2">Serie</td><td style="text-align: right;">95.8</td></tr> <tr><td colspan="2">Total</td><td style="text-align: right;">0.0</td></tr> </table>	1:	9.3	→	2:	9.1	→	3:	9.6	→	4:	10.8x	→	5:	10.6x	↗	6:	8.3	→	7:	9.8	↑	8:	9.5	←	9:	8.3	→	10:	10.5x	↙	Serie		95.8	Total		0.0	<p>Prov</p>  <table border="1" style="width:100%; border-collapse: collapse;"> <tr><td>11:</td><td>10.0</td><td>↗</td></tr> <tr><td>12:</td><td>9.7</td><td>→</td></tr> <tr><td>13:</td><td>9.0</td><td>→</td></tr> <tr><td>14:</td><td>9.0</td><td>→</td></tr> <tr><td colspan="2">Serie</td><td style="text-align: right;">37.7</td></tr> <tr><td colspan="2">Total</td><td style="text-align: right;">0.0</td></tr> </table>	11:	10.0	↗	12:	9.7	→	13:	9.0	→	14:	9.0	→	Serie		37.7	Total		0.0
1:	9.3	→																																																						
2:	9.1	→																																																						
3:	9.6	→																																																						
4:	10.8x	→																																																						
5:	10.6x	↗																																																						
6:	8.3	→																																																						
7:	9.8	↑																																																						
8:	9.5	←																																																						
9:	8.3	→																																																						
10:	10.5x	↙																																																						
Serie		95.8																																																						
Total		0.0																																																						
11:	10.0	↗																																																						
12:	9.7	→																																																						
13:	9.0	→																																																						
14:	9.0	→																																																						
Serie		37.7																																																						
Total		0.0																																																						

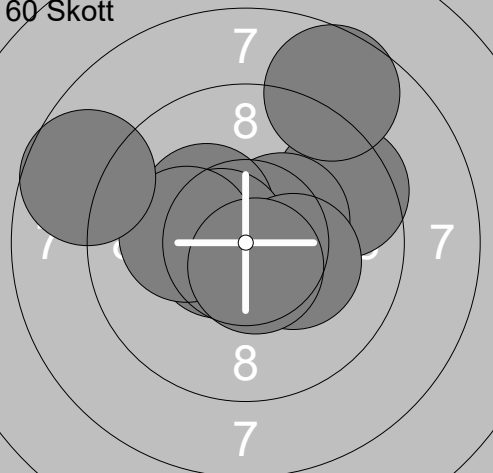
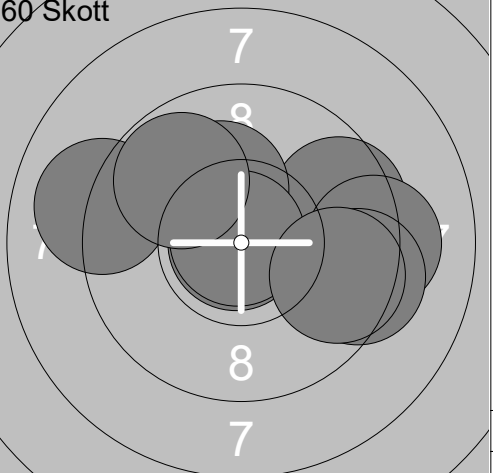
<p>60 Skott</p> 	<table border="1" style="width:100%; border-collapse: collapse;"> <tr><td>1:</td><td>10.6x</td><td>←</td></tr> <tr><td>2:</td><td>9.5</td><td>↗</td></tr> <tr><td>3:</td><td>8.7</td><td>↗</td></tr> <tr><td>4:</td><td>10.4x</td><td>↗</td></tr> <tr><td>5:</td><td>10.3x</td><td>↗</td></tr> <tr><td>6:</td><td>10.6x</td><td>←</td></tr> <tr><td>7:</td><td>10.3x</td><td>→</td></tr> <tr><td>8:</td><td>10.2x</td><td>←</td></tr> <tr><td>9:</td><td>8.7</td><td>↖</td></tr> <tr><td>10:</td><td>10.6x</td><td>↘</td></tr> <tr><td colspan="2">Serie</td><td style="text-align: right;">99.9</td></tr> <tr><td colspan="2">Total</td><td style="text-align: right;">99.9</td></tr> </table>	1:	10.6x	←	2:	9.5	↗	3:	8.7	↗	4:	10.4x	↗	5:	10.3x	↗	6:	10.6x	←	7:	10.3x	→	8:	10.2x	←	9:	8.7	↖	10:	10.6x	↘	Serie		99.9	Total		99.9	<p>60 Skott</p>  <table border="1" style="width:100%; border-collapse: collapse;"> <tr><td>11:</td><td>10.9x</td><td>←</td></tr> <tr><td>12:</td><td>9.6</td><td>↗</td></tr> <tr><td>13:</td><td>10.2x</td><td>↗</td></tr> <tr><td>14:</td><td>9.2</td><td>→</td></tr> <tr><td>15:</td><td>10.2x</td><td>↗</td></tr> <tr><td>16:</td><td>9.4</td><td>→</td></tr> <tr><td>17:</td><td>9.0</td><td>←</td></tr> <tr><td>18:</td><td>10.9x</td><td>↗</td></tr> <tr><td>19:</td><td>9.6</td><td>→</td></tr> <tr><td>20:</td><td>9.8</td><td>↗</td></tr> <tr><td colspan="2">Serie</td><td style="text-align: right;">98.8</td></tr> <tr><td colspan="2">Total</td><td style="text-align: right;">198.7</td></tr> </table>	11:	10.9x	←	12:	9.6	↗	13:	10.2x	↗	14:	9.2	→	15:	10.2x	↗	16:	9.4	→	17:	9.0	←	18:	10.9x	↗	19:	9.6	→	20:	9.8	↗	Serie		98.8	Total		198.7
1:	10.6x	←																																																																								
2:	9.5	↗																																																																								
3:	8.7	↗																																																																								
4:	10.4x	↗																																																																								
5:	10.3x	↗																																																																								
6:	10.6x	←																																																																								
7:	10.3x	→																																																																								
8:	10.2x	←																																																																								
9:	8.7	↖																																																																								
10:	10.6x	↘																																																																								
Serie		99.9																																																																								
Total		99.9																																																																								
11:	10.9x	←																																																																								
12:	9.6	↗																																																																								
13:	10.2x	↗																																																																								
14:	9.2	→																																																																								
15:	10.2x	↗																																																																								
16:	9.4	→																																																																								
17:	9.0	←																																																																								
18:	10.9x	↗																																																																								
19:	9.6	→																																																																								
20:	9.8	↗																																																																								
Serie		98.8																																																																								
Total		198.7																																																																								

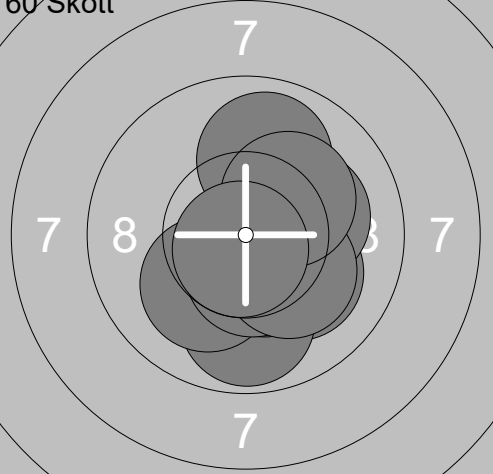
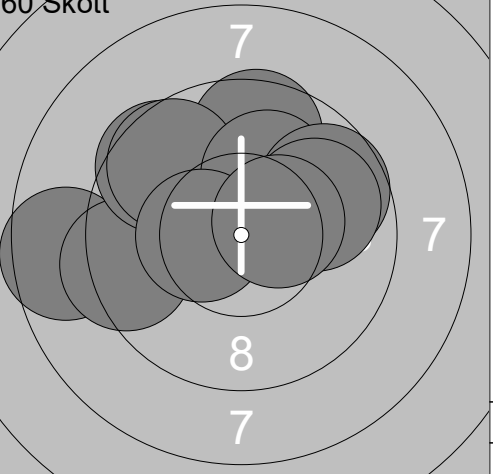
<p>60 Skott</p> 	<table border="1" style="width:100%; border-collapse: collapse;"> <tr><td>21:</td><td>10.1</td><td>↘</td></tr> <tr><td>22:</td><td>9.8</td><td>↓</td></tr> <tr><td>23:</td><td>10.2x</td><td>→</td></tr> <tr><td>24:</td><td>10.4x</td><td>↘</td></tr> <tr><td>25:</td><td>9.9</td><td>↑</td></tr> <tr><td>26:</td><td>10.1</td><td>↘</td></tr> <tr><td>27:</td><td>10.5x</td><td>↓</td></tr> <tr><td>28:</td><td>10.2x</td><td>↘</td></tr> <tr><td>29:</td><td>10.2x</td><td>↗</td></tr> <tr><td>30:</td><td>10.7x</td><td>↘</td></tr> <tr><td colspan="2">Serie</td><td style="text-align: right;">102.1</td></tr> <tr><td colspan="2">Total</td><td style="text-align: right;">300.8</td></tr> </table>	21:	10.1	↘	22:	9.8	↓	23:	10.2x	→	24:	10.4x	↘	25:	9.9	↑	26:	10.1	↘	27:	10.5x	↓	28:	10.2x	↘	29:	10.2x	↗	30:	10.7x	↘	Serie		102.1	Total		300.8	<p>60 Skott</p>  <table border="1" style="width:100%; border-collapse: collapse;"> <tr><td>31:</td><td>8.6</td><td>←</td></tr> <tr><td>32:</td><td>9.4</td><td>←</td></tr> <tr><td>33:</td><td>9.6</td><td>↑</td></tr> <tr><td>34:</td><td>9.5</td><td>↖</td></tr> <tr><td>35:</td><td>9.6</td><td>↗</td></tr> <tr><td>36:</td><td>10.1</td><td>↑</td></tr> <tr><td>37:</td><td>9.7</td><td>↗</td></tr> <tr><td>38:</td><td>10.4x</td><td>←</td></tr> <tr><td>39:</td><td>9.9</td><td>↗</td></tr> <tr><td>40:</td><td>10.4x</td><td>→</td></tr> <tr><td colspan="2">Serie</td><td style="text-align: right;">97.2</td></tr> <tr><td colspan="2">Total</td><td style="text-align: right;">398.0</td></tr> </table>	31:	8.6	←	32:	9.4	←	33:	9.6	↑	34:	9.5	↖	35:	9.6	↗	36:	10.1	↑	37:	9.7	↗	38:	10.4x	←	39:	9.9	↗	40:	10.4x	→	Serie		97.2	Total		398.0
21:	10.1	↘																																																																								
22:	9.8	↓																																																																								
23:	10.2x	→																																																																								
24:	10.4x	↘																																																																								
25:	9.9	↑																																																																								
26:	10.1	↘																																																																								
27:	10.5x	↓																																																																								
28:	10.2x	↘																																																																								
29:	10.2x	↗																																																																								
30:	10.7x	↘																																																																								
Serie		102.1																																																																								
Total		300.8																																																																								
31:	8.6	←																																																																								
32:	9.4	←																																																																								
33:	9.6	↑																																																																								
34:	9.5	↖																																																																								
35:	9.6	↗																																																																								
36:	10.1	↑																																																																								
37:	9.7	↗																																																																								
38:	10.4x	←																																																																								
39:	9.9	↗																																																																								
40:	10.4x	→																																																																								
Serie		97.2																																																																								
Total		398.0																																																																								

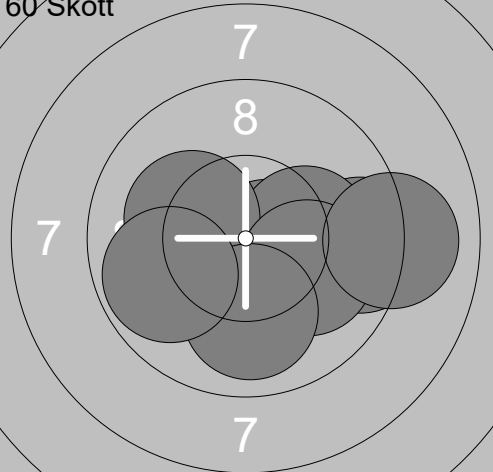
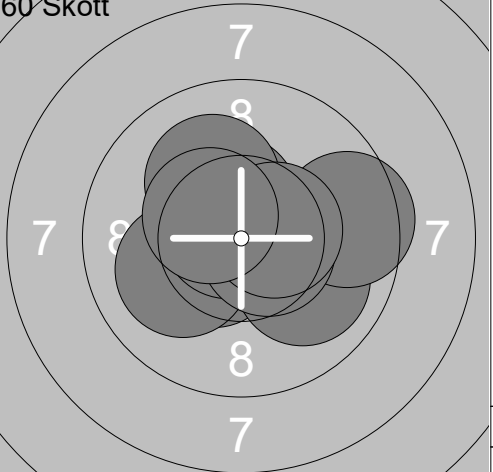
<p>60 Skott</p> 	<table border="1" style="width:100%; border-collapse: collapse;"> <tr><td>41:</td><td>9.4</td><td>→</td></tr> <tr><td>42:</td><td>10.7x</td><td>↓</td></tr> <tr><td>43:</td><td>10.6x</td><td>←</td></tr> <tr><td>44:</td><td>10.6x</td><td>↘</td></tr> <tr><td>45:</td><td>10.2x</td><td>→</td></tr> <tr><td>46:</td><td>10.2x</td><td>↖</td></tr> <tr><td>47:</td><td>10.1</td><td>↘</td></tr> <tr><td>48:</td><td>10.0</td><td>↓</td></tr> <tr><td>49:</td><td>9.0</td><td>→</td></tr> <tr><td>50:</td><td>9.8</td><td>↖</td></tr> <tr><td colspan="2">Serie</td><td style="text-align: right;">100.6</td></tr> <tr><td colspan="2">Total</td><td style="text-align: right;">498.6</td></tr> </table>	41:	9.4	→	42:	10.7x	↓	43:	10.6x	←	44:	10.6x	↘	45:	10.2x	→	46:	10.2x	↖	47:	10.1	↘	48:	10.0	↓	49:	9.0	→	50:	9.8	↖	Serie		100.6	Total		498.6	<p>60 Skott</p>  <table border="1" style="width:100%; border-collapse: collapse;"> <tr><td>51:</td><td>10.5x</td><td>↙</td></tr> <tr><td>52:</td><td>10.0</td><td>↘</td></tr> <tr><td>53:</td><td>10.5x</td><td>↗</td></tr> <tr><td>54:</td><td>10.1</td><td>↗</td></tr> <tr><td>55:</td><td>10.1</td><td>←</td></tr> <tr><td>56:</td><td>9.5</td><td>→</td></tr> <tr><td>57:</td><td>10.8x</td><td>↖</td></tr> <tr><td>58:</td><td>10.6x</td><td>↘</td></tr> <tr><td>59:</td><td>10.5x</td><td>→</td></tr> <tr><td>60:</td><td>10.4x</td><td>↖</td></tr> <tr><td colspan="2">Serie</td><td style="text-align: right;">103.0</td></tr> <tr><td colspan="2">Total</td><td style="text-align: right;">601.6</td></tr> </table>	51:	10.5x	↙	52:	10.0	↘	53:	10.5x	↗	54:	10.1	↗	55:	10.1	←	56:	9.5	→	57:	10.8x	↖	58:	10.6x	↘	59:	10.5x	→	60:	10.4x	↖	Serie		103.0	Total		601.6
41:	9.4	→																																																																								
42:	10.7x	↓																																																																								
43:	10.6x	←																																																																								
44:	10.6x	↘																																																																								
45:	10.2x	→																																																																								
46:	10.2x	↖																																																																								
47:	10.1	↘																																																																								
48:	10.0	↓																																																																								
49:	9.0	→																																																																								
50:	9.8	↖																																																																								
Serie		100.6																																																																								
Total		498.6																																																																								
51:	10.5x	↙																																																																								
52:	10.0	↘																																																																								
53:	10.5x	↗																																																																								
54:	10.1	↗																																																																								
55:	10.1	←																																																																								
56:	9.5	→																																																																								
57:	10.8x	↖																																																																								
58:	10.6x	↘																																																																								
59:	10.5x	→																																																																								
60:	10.4x	↖																																																																								
Serie		103.0																																																																								
Total		601.6																																																																								

<p>Pröv</p>	<table border="1" style="width:100%; border-collapse: collapse;"> <tr><td>1:</td><td>8.8</td><td>←</td></tr> <tr><td>2:</td><td>9.0</td><td>↖</td></tr> <tr><td>3:</td><td>9.5</td><td>↑</td></tr> <tr><td>4:</td><td>10.1</td><td>→</td></tr> <tr><td>5:</td><td>10.3x</td><td>→</td></tr> <tr><td>6:</td><td>9.3</td><td>→</td></tr> <tr><td>7:</td><td>10.2x</td><td>→</td></tr> <tr><td>8:</td><td>10.1</td><td>↑</td></tr> <tr><td>9:</td><td>10.4x</td><td>↙</td></tr> <tr><td>10:</td><td>9.3</td><td>←</td></tr> <tr><td colspan="2">Serie</td><td>97.0</td></tr> <tr><td colspan="2">Total</td><td>0.0</td></tr> </table>	1:	8.8	←	2:	9.0	↖	3:	9.5	↑	4:	10.1	→	5:	10.3x	→	6:	9.3	→	7:	10.2x	→	8:	10.1	↑	9:	10.4x	↙	10:	9.3	←	Serie		97.0	Total		0.0	<p>Pröv</p>	<table border="1" style="width:100%; border-collapse: collapse;"> <tr><td>11:</td><td>10.5x</td><td>↓</td></tr> <tr><td colspan="2">Serie</td><td>10.5</td></tr> <tr><td colspan="2">Total</td><td>0.0</td></tr> </table>	11:	10.5x	↓	Serie		10.5	Total		0.0
1:	8.8	←																																														
2:	9.0	↖																																														
3:	9.5	↑																																														
4:	10.1	→																																														
5:	10.3x	→																																														
6:	9.3	→																																														
7:	10.2x	→																																														
8:	10.1	↑																																														
9:	10.4x	↙																																														
10:	9.3	←																																														
Serie		97.0																																														
Total		0.0																																														
11:	10.5x	↓																																														
Serie		10.5																																														
Total		0.0																																														

<p>60 Skott</p>	<table border="1" style="width:100%; border-collapse: collapse;"> <tr><td>1:</td><td>10.6x</td><td>↑</td></tr> <tr><td>2:</td><td>10.5x</td><td>↖</td></tr> <tr><td>3:</td><td>9.9</td><td>↙</td></tr> <tr><td>4:</td><td>10.1</td><td>↙</td></tr> <tr><td>5:</td><td>9.9</td><td>↑</td></tr> <tr><td>6:</td><td>9.6</td><td>↑</td></tr> <tr><td>7:</td><td>9.0</td><td>↗</td></tr> <tr><td>8:</td><td>8.7</td><td>↙</td></tr> <tr><td>9:</td><td>10.3x</td><td>↘</td></tr> <tr><td>10:</td><td>10.2x</td><td>↘</td></tr> <tr><td colspan="2">Serie</td><td>98.8</td></tr> <tr><td colspan="2">Total</td><td>98.8</td></tr> </table>	1:	10.6x	↑	2:	10.5x	↖	3:	9.9	↙	4:	10.1	↙	5:	9.9	↑	6:	9.6	↑	7:	9.0	↗	8:	8.7	↙	9:	10.3x	↘	10:	10.2x	↘	Serie		98.8	Total		98.8	<p>60 Skott</p>	<table border="1" style="width:100%; border-collapse: collapse;"> <tr><td>11:</td><td>10.4x</td><td>→</td></tr> <tr><td>12:</td><td>9.5</td><td>↙</td></tr> <tr><td>13:</td><td>10.3x</td><td>←</td></tr> <tr><td>14:</td><td>10.0</td><td>↖</td></tr> <tr><td>15:</td><td>9.3</td><td>↗</td></tr> <tr><td>16:</td><td>9.6</td><td>↓</td></tr> <tr><td>17:</td><td>10.4x</td><td>↑</td></tr> <tr><td>18:</td><td>9.9</td><td>→</td></tr> <tr><td>19:</td><td>9.4</td><td>↙</td></tr> <tr><td>20:</td><td>10.7x</td><td>↓</td></tr> <tr><td colspan="2">Serie</td><td>99.5</td></tr> <tr><td colspan="2">Total</td><td>198.3</td></tr> </table>	11:	10.4x	→	12:	9.5	↙	13:	10.3x	←	14:	10.0	↖	15:	9.3	↗	16:	9.6	↓	17:	10.4x	↑	18:	9.9	→	19:	9.4	↙	20:	10.7x	↓	Serie		99.5	Total		198.3
1:	10.6x	↑																																																																									
2:	10.5x	↖																																																																									
3:	9.9	↙																																																																									
4:	10.1	↙																																																																									
5:	9.9	↑																																																																									
6:	9.6	↑																																																																									
7:	9.0	↗																																																																									
8:	8.7	↙																																																																									
9:	10.3x	↘																																																																									
10:	10.2x	↘																																																																									
Serie		98.8																																																																									
Total		98.8																																																																									
11:	10.4x	→																																																																									
12:	9.5	↙																																																																									
13:	10.3x	←																																																																									
14:	10.0	↖																																																																									
15:	9.3	↗																																																																									
16:	9.6	↓																																																																									
17:	10.4x	↑																																																																									
18:	9.9	→																																																																									
19:	9.4	↙																																																																									
20:	10.7x	↓																																																																									
Serie		99.5																																																																									
Total		198.3																																																																									

<p>60 Skott</p>	<table border="1" style="width:100%; border-collapse: collapse;"> <tr><td>21:</td><td>9.4</td><td>↑</td></tr> <tr><td>22:</td><td>9.7</td><td>←</td></tr> <tr><td>23:</td><td>10.4x</td><td>↗</td></tr> <tr><td>24:</td><td>10.3x</td><td>↗</td></tr> <tr><td>25:</td><td>10.1</td><td>↗</td></tr> <tr><td>26:</td><td>10.5x</td><td>↓</td></tr> <tr><td>27:</td><td>9.7</td><td>←</td></tr> <tr><td>28:</td><td>9.9</td><td>↓</td></tr> <tr><td>29:</td><td>10.4x</td><td>↘</td></tr> <tr><td>30:</td><td>10.6x</td><td>↖</td></tr> <tr><td colspan="2">Serie</td><td>101.0</td></tr> <tr><td colspan="2">Total</td><td>299.3</td></tr> </table>	21:	9.4	↑	22:	9.7	←	23:	10.4x	↗	24:	10.3x	↗	25:	10.1	↗	26:	10.5x	↓	27:	9.7	←	28:	9.9	↓	29:	10.4x	↘	30:	10.6x	↖	Serie		101.0	Total		299.3	<p>60 Skott</p>	<table border="1" style="width:100%; border-collapse: collapse;"> <tr><td>31:</td><td>10.5x</td><td>↗</td></tr> <tr><td>32:</td><td>10.3x</td><td>↗</td></tr> <tr><td>33:</td><td>10.1</td><td>↗</td></tr> <tr><td>34:</td><td>9.6</td><td>←</td></tr> <tr><td>35:</td><td>10.5x</td><td>↑</td></tr> <tr><td>36:</td><td>10.1</td><td>↘</td></tr> <tr><td>37:</td><td>10.3x</td><td>↓</td></tr> <tr><td>38:</td><td>9.5</td><td>↙</td></tr> <tr><td>39:</td><td>10.7x</td><td>↓</td></tr> <tr><td>40:</td><td>10.3x</td><td>↖</td></tr> <tr><td colspan="2">Serie</td><td>101.9</td></tr> <tr><td colspan="2">Total</td><td>401.2</td></tr> </table>	31:	10.5x	↗	32:	10.3x	↗	33:	10.1	↗	34:	9.6	←	35:	10.5x	↑	36:	10.1	↘	37:	10.3x	↓	38:	9.5	↙	39:	10.7x	↓	40:	10.3x	↖	Serie		101.9	Total		401.2
21:	9.4	↑																																																																									
22:	9.7	←																																																																									
23:	10.4x	↗																																																																									
24:	10.3x	↗																																																																									
25:	10.1	↗																																																																									
26:	10.5x	↓																																																																									
27:	9.7	←																																																																									
28:	9.9	↓																																																																									
29:	10.4x	↘																																																																									
30:	10.6x	↖																																																																									
Serie		101.0																																																																									
Total		299.3																																																																									
31:	10.5x	↗																																																																									
32:	10.3x	↗																																																																									
33:	10.1	↗																																																																									
34:	9.6	←																																																																									
35:	10.5x	↑																																																																									
36:	10.1	↘																																																																									
37:	10.3x	↓																																																																									
38:	9.5	↙																																																																									
39:	10.7x	↓																																																																									
40:	10.3x	↖																																																																									
Serie		101.9																																																																									
Total		401.2																																																																									

<p>60 Skott</p>	<table border="1" style="width:100%; border-collapse: collapse;"> <tr><td>41:</td><td>10.4x</td><td>↙</td></tr> <tr><td>42:</td><td>9.7</td><td>←</td></tr> <tr><td>43:</td><td>9.4</td><td>↑</td></tr> <tr><td>44:</td><td>10.1</td><td>↗</td></tr> <tr><td>45:</td><td>9.6</td><td>→</td></tr> <tr><td>46:</td><td>10.5x</td><td>↗</td></tr> <tr><td>47:</td><td>10.5x</td><td>↗</td></tr> <tr><td>48:</td><td>9.5</td><td>↘</td></tr> <tr><td>49:</td><td>10.3x</td><td>↘</td></tr> <tr><td>50:</td><td>10.3x</td><td>↗</td></tr> <tr><td colspan="2">Serie</td><td>100.3</td></tr> <tr><td colspan="2">Total</td><td>501.5</td></tr> </table>	41:	10.4x	↙	42:	9.7	←	43:	9.4	↑	44:	10.1	↗	45:	9.6	→	46:	10.5x	↗	47:	10.5x	↗	48:	9.5	↘	49:	10.3x	↘	50:	10.3x	↗	Serie		100.3	Total		501.5	<p>60 Skott</p>	<table border="1" style="width:100%; border-collapse: collapse;"> <tr><td>51:</td><td>9.7</td><td>↓</td></tr> <tr><td>52:</td><td>10.3x</td><td>↖</td></tr> <tr><td>53:</td><td>9.9</td><td>→</td></tr> <tr><td>54:</td><td>10.3x</td><td>→</td></tr> <tr><td>55:</td><td>10.8x</td><td>↗</td></tr> <tr><td>56:</td><td>10.7x</td><td>→</td></tr> <tr><td>57:</td><td>10.4x</td><td>↗</td></tr> <tr><td>58:</td><td>9.1</td><td>↓</td></tr> <tr><td>59:</td><td>10.3x</td><td>↙</td></tr> <tr><td>60:</td><td>10.7x</td><td>↗</td></tr> <tr><td colspan="2">Serie</td><td>102.2</td></tr> <tr><td colspan="2">Total</td><td>603.7</td></tr> </table>	51:	9.7	↓	52:	10.3x	↖	53:	9.9	→	54:	10.3x	→	55:	10.8x	↗	56:	10.7x	→	57:	10.4x	↗	58:	9.1	↓	59:	10.3x	↙	60:	10.7x	↗	Serie		102.2	Total		603.7
41:	10.4x	↙																																																																									
42:	9.7	←																																																																									
43:	9.4	↑																																																																									
44:	10.1	↗																																																																									
45:	9.6	→																																																																									
46:	10.5x	↗																																																																									
47:	10.5x	↗																																																																									
48:	9.5	↘																																																																									
49:	10.3x	↘																																																																									
50:	10.3x	↗																																																																									
Serie		100.3																																																																									
Total		501.5																																																																									
51:	9.7	↓																																																																									
52:	10.3x	↖																																																																									
53:	9.9	→																																																																									
54:	10.3x	→																																																																									
55:	10.8x	↗																																																																									
56:	10.7x	→																																																																									
57:	10.4x	↗																																																																									
58:	9.1	↓																																																																									
59:	10.3x	↙																																																																									
60:	10.7x	↗																																																																									
Serie		102.2																																																																									
Total		603.7																																																																									

<p>Prov</p>	<table border="1" style="width:100%; border-collapse: collapse;"> <tr><td>1:</td><td>10.6x</td><td>↗</td></tr> <tr><td>2:</td><td>10.2x</td><td>↓</td></tr> <tr><td>3:</td><td>9.2</td><td>→</td></tr> <tr><td>4:</td><td>10.8x</td><td>↖</td></tr> <tr><td>5:</td><td>9.6</td><td>↗</td></tr> <tr><td>6:</td><td>10.5x</td><td>↖</td></tr> <tr><td>7:</td><td>9.5</td><td>↓</td></tr> <tr><td>8:</td><td>9.6</td><td>↘</td></tr> <tr><td>9:</td><td>9.5</td><td>↗</td></tr> <tr><td>10:</td><td>7.8</td><td>←</td></tr> <tr><td colspan="2">Serie</td><td style="text-align: right;">97.3</td></tr> <tr><td colspan="2">Total</td><td style="text-align: right;">0.0</td></tr> </table>	1:	10.6x	↗	2:	10.2x	↓	3:	9.2	→	4:	10.8x	↖	5:	9.6	↗	6:	10.5x	↖	7:	9.5	↓	8:	9.6	↘	9:	9.5	↗	10:	7.8	←	Serie		97.3	Total		0.0	<p>Prov</p>	<table border="1" style="width:100%; border-collapse: collapse;"> <tr><td>11:</td><td>9.4</td><td>↖</td></tr> <tr><td>12:</td><td>8.4</td><td>↑</td></tr> <tr><td>13:</td><td>10.6x</td><td>↗</td></tr> <tr><td>14:</td><td>9.6</td><td>↖</td></tr> <tr><td>15:</td><td>9.5</td><td>↗</td></tr> <tr><td>16:</td><td>7.8</td><td>↖</td></tr> <tr><td>17:</td><td>8.8</td><td>↑</td></tr> <tr><td>18:</td><td>9.8</td><td>↗</td></tr> <tr><td>19:</td><td>8.5</td><td>↗</td></tr> <tr><td>20:</td><td>10.0</td><td>↖</td></tr> <tr><td colspan="2">Serie</td><td style="text-align: right;">92.4</td></tr> <tr><td colspan="2">Total</td><td style="text-align: right;">0.0</td></tr> </table>	11:	9.4	↖	12:	8.4	↑	13:	10.6x	↗	14:	9.6	↖	15:	9.5	↗	16:	7.8	↖	17:	8.8	↑	18:	9.8	↗	19:	8.5	↗	20:	10.0	↖	Serie		92.4	Total		0.0
1:	10.6x	↗																																																																									
2:	10.2x	↓																																																																									
3:	9.2	→																																																																									
4:	10.8x	↖																																																																									
5:	9.6	↗																																																																									
6:	10.5x	↖																																																																									
7:	9.5	↓																																																																									
8:	9.6	↘																																																																									
9:	9.5	↗																																																																									
10:	7.8	←																																																																									
Serie		97.3																																																																									
Total		0.0																																																																									
11:	9.4	↖																																																																									
12:	8.4	↑																																																																									
13:	10.6x	↗																																																																									
14:	9.6	↖																																																																									
15:	9.5	↗																																																																									
16:	7.8	↖																																																																									
17:	8.8	↑																																																																									
18:	9.8	↗																																																																									
19:	8.5	↗																																																																									
20:	10.0	↖																																																																									
Serie		92.4																																																																									
Total		0.0																																																																									

<p>Prov</p>	<table border="1" style="width:100%; border-collapse: collapse;"> <tr><td>21:</td><td>10.2x</td><td>↖</td></tr> <tr><td>22:</td><td>7.4</td><td>↗</td></tr> <tr><td>23:</td><td>10.1</td><td>↓</td></tr> <tr><td>24:</td><td>10.5x</td><td>↗</td></tr> <tr><td colspan="2">Serie</td><td style="text-align: right;">38.2</td></tr> <tr><td colspan="2">Total</td><td style="text-align: right;">0.0</td></tr> </table>	21:	10.2x	↖	22:	7.4	↗	23:	10.1	↓	24:	10.5x	↗	Serie		38.2	Total		0.0	<p>60 Skott</p>	<table border="1" style="width:100%; border-collapse: collapse;"> <tr><td>1:</td><td>9.1</td><td>→</td></tr> <tr><td>2:</td><td>9.9</td><td>↖</td></tr> <tr><td>3:</td><td>10.6x</td><td>↑</td></tr> <tr><td>4:</td><td>10.2x</td><td>←</td></tr> <tr><td>5:</td><td>9.7</td><td>↖</td></tr> <tr><td>6:</td><td>8.7</td><td>→</td></tr> <tr><td>7:</td><td>9.3</td><td>↗</td></tr> <tr><td>8:</td><td>9.8</td><td>↘</td></tr> <tr><td>9:</td><td>9.5</td><td>↘</td></tr> <tr><td>10:</td><td>10.0</td><td>↗</td></tr> <tr><td colspan="2">Serie</td><td style="text-align: right;">96.8</td></tr> <tr><td colspan="2">Total</td><td style="text-align: right;">96.8</td></tr> </table>	1:	9.1	→	2:	9.9	↖	3:	10.6x	↑	4:	10.2x	←	5:	9.7	↖	6:	8.7	→	7:	9.3	↗	8:	9.8	↘	9:	9.5	↘	10:	10.0	↗	Serie		96.8	Total		96.8
21:	10.2x	↖																																																							
22:	7.4	↗																																																							
23:	10.1	↓																																																							
24:	10.5x	↗																																																							
Serie		38.2																																																							
Total		0.0																																																							
1:	9.1	→																																																							
2:	9.9	↖																																																							
3:	10.6x	↑																																																							
4:	10.2x	←																																																							
5:	9.7	↖																																																							
6:	8.7	→																																																							
7:	9.3	↗																																																							
8:	9.8	↘																																																							
9:	9.5	↘																																																							
10:	10.0	↗																																																							
Serie		96.8																																																							
Total		96.8																																																							

<p>60 Skott</p>	<table border="1" style="width:100%; border-collapse: collapse;"> <tr><td>11:</td><td>9.4</td><td>→</td></tr> <tr><td>12:</td><td>8.5</td><td>↗</td></tr> <tr><td>13:</td><td>9.6</td><td>↗</td></tr> <tr><td>14:</td><td>8.3</td><td>↗</td></tr> <tr><td>15:</td><td>8.4</td><td>↗</td></tr> <tr><td>16:</td><td>9.1</td><td>↑</td></tr> <tr><td>17:</td><td>10.3x</td><td>↑</td></tr> <tr><td>18:</td><td>8.9</td><td>↗</td></tr> <tr><td>19:</td><td>9.1</td><td>←</td></tr> <tr><td>20:</td><td>10.3x</td><td>↗</td></tr> <tr><td colspan="2">Serie</td><td style="text-align: right;">91.9</td></tr> <tr><td colspan="2">Total</td><td style="text-align: right;">188.7</td></tr> </table>	11:	9.4	→	12:	8.5	↗	13:	9.6	↗	14:	8.3	↗	15:	8.4	↗	16:	9.1	↑	17:	10.3x	↑	18:	8.9	↗	19:	9.1	←	20:	10.3x	↗	Serie		91.9	Total		188.7	<p>60 Skott</p>	<table border="1" style="width:100%; border-collapse: collapse;"> <tr><td>21:</td><td>10.0</td><td>→</td></tr> <tr><td>22:</td><td>9.6</td><td>↓</td></tr> <tr><td>23:</td><td>10.7x</td><td>↘</td></tr> <tr><td>24:</td><td>10.3x</td><td>↓</td></tr> <tr><td>25:</td><td>10.1</td><td>↘</td></tr> <tr><td>26:</td><td>9.9</td><td>←</td></tr> <tr><td>27:</td><td>9.4</td><td>↗</td></tr> <tr><td>28:</td><td>7.8</td><td>→</td></tr> <tr><td>29:</td><td>9.2</td><td>↗</td></tr> <tr><td>30:</td><td>8.6</td><td>↗</td></tr> <tr><td colspan="2">Serie</td><td style="text-align: right;">95.6</td></tr> <tr><td colspan="2">Total</td><td style="text-align: right;">284.3</td></tr> </table>	21:	10.0	→	22:	9.6	↓	23:	10.7x	↘	24:	10.3x	↓	25:	10.1	↘	26:	9.9	←	27:	9.4	↗	28:	7.8	→	29:	9.2	↗	30:	8.6	↗	Serie		95.6	Total		284.3
11:	9.4	→																																																																									
12:	8.5	↗																																																																									
13:	9.6	↗																																																																									
14:	8.3	↗																																																																									
15:	8.4	↗																																																																									
16:	9.1	↑																																																																									
17:	10.3x	↑																																																																									
18:	8.9	↗																																																																									
19:	9.1	←																																																																									
20:	10.3x	↗																																																																									
Serie		91.9																																																																									
Total		188.7																																																																									
21:	10.0	→																																																																									
22:	9.6	↓																																																																									
23:	10.7x	↘																																																																									
24:	10.3x	↓																																																																									
25:	10.1	↘																																																																									
26:	9.9	←																																																																									
27:	9.4	↗																																																																									
28:	7.8	→																																																																									
29:	9.2	↗																																																																									
30:	8.6	↗																																																																									
Serie		95.6																																																																									
Total		284.3																																																																									

<p>60 Skott</p>	<table border="1" style="width:100%; border-collapse: collapse;"> <tr><td>31:</td><td>10.4x</td><td>↗</td></tr> <tr><td>32:</td><td>7.2</td><td>→</td></tr> <tr><td>33:</td><td>10.1</td><td>↘</td></tr> <tr><td>34:</td><td>10.9x</td><td>↗</td></tr> <tr><td>35:</td><td>8.9</td><td>→</td></tr> <tr><td>36:</td><td>8.5</td><td>↗</td></tr> <tr><td>37:</td><td>9.2</td><td>↗</td></tr> <tr><td>38:</td><td>9.5</td><td>↗</td></tr> <tr><td>39:</td><td>9.4</td><td>↑</td></tr> <tr><td>40:</td><td>8.4</td><td>←</td></tr> <tr><td colspan="2">Serie</td><td style="text-align: right;">92.5</td></tr> <tr><td colspan="2">Total</td><td style="text-align: right;">376.8</td></tr> </table>	31:	10.4x	↗	32:	7.2	→	33:	10.1	↘	34:	10.9x	↗	35:	8.9	→	36:	8.5	↗	37:	9.2	↗	38:	9.5	↗	39:	9.4	↑	40:	8.4	←	Serie		92.5	Total		376.8		
31:	10.4x	↗																																					
32:	7.2	→																																					
33:	10.1	↘																																					
34:	10.9x	↗																																					
35:	8.9	→																																					
36:	8.5	↗																																					
37:	9.2	↗																																					
38:	9.5	↗																																					
39:	9.4	↑																																					
40:	8.4	←																																					
Serie		92.5																																					
Total		376.8																																					

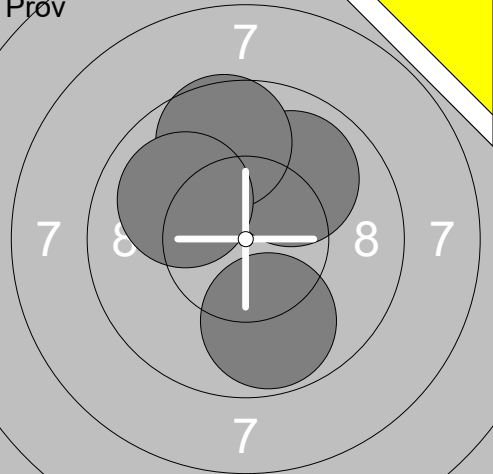
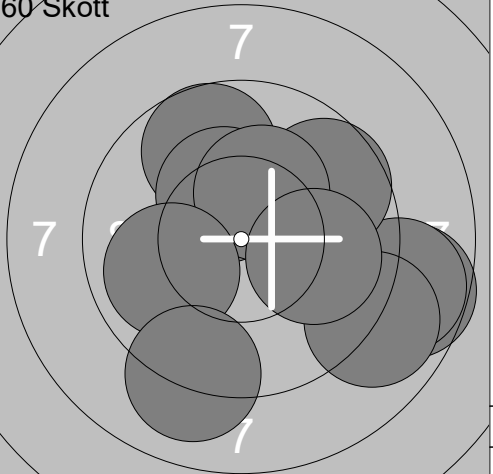
<p>Pröv</p> 	<p>1: 9.9 ↗ 2: 9.8 ↓ 3: 9.6 ↑ 4: 10.0 ↖</p>	<p>60 Skott</p> 	<p>1: 8.6 → 2: 9.7 ↗ 3: 8.8 → 4: 10.3x ↗ 5: 9.7 ↗ 6: 10.3x ↗ 7: 8.9 → 8: 9.9 ← 9: 10.0 → 10: 9.1 ↓</p>
Serie 39.3		Serie 95.3	
Total 0.0		Total 95.3	

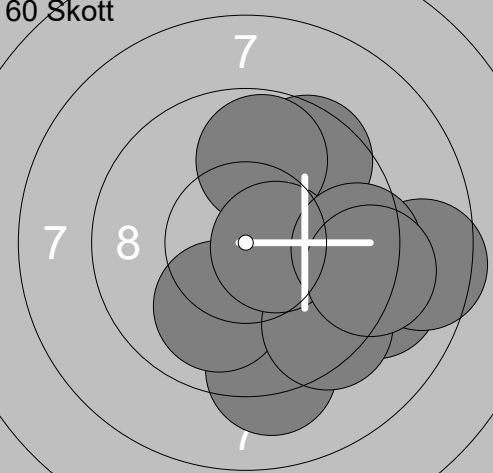
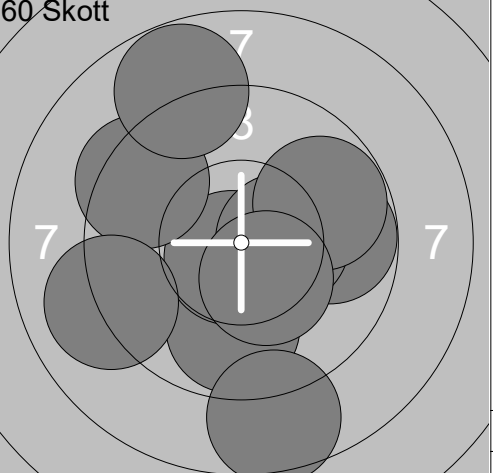
<p>60 Skott</p> 	<p>11: 9.2 ↓ 12: 9.6 ↗ 13: 9.8 ↑ 14: 9.1 → 15: 10.0 ↓ 16: 9.4 ↓ 17: 10.5x → 18: 8.5 → 19: 9.4 → 20: 9.2 →</p>	<p>60 Skott</p> 	<p>21: 9.8 ↓ 22: 10.7x ↓ 23: 8.6 ↓ 24: 9.4 ↖ 25: 9.8 → 26: 9.0 ← 27: 10.4x → 28: 9.8 ↗ 29: 10.4x ↓ 30: 8.8 ↗</p>
Serie 94.7		Serie 96.7	
Total 190.0		Total 286.7	

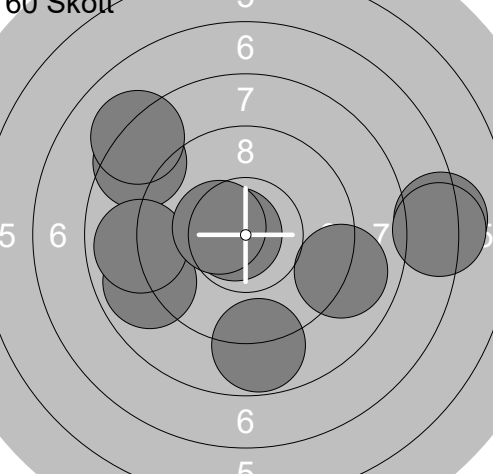
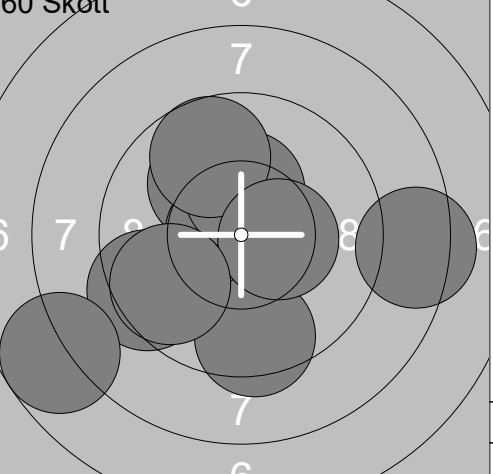
<p>60 Skott</p> 	<p>31: 8.5 ↖ 32: 8.8 ↓ 33: 7.2 → 34: 10.8x ← 35: 8.9 ← 36: 8.9 ← 37: 9.0 → 38: 10.4x ← 39: 7.2 → 40: 8.1 ↗</p>	<p>60 Skott</p> 	<p>41: 10.0 ↖ 42: 10.7x ← 43: 9.4 ↓ 44: 9.3 ← 45: 7.8 ← 46: 8.4 → 47: 10.3x ↑ 48: 9.7 ↗ 49: 10.4x → 50: 9.7 ↖</p>
Serie 87.8		Serie 95.7	
Total 374.5		Total 470.2	

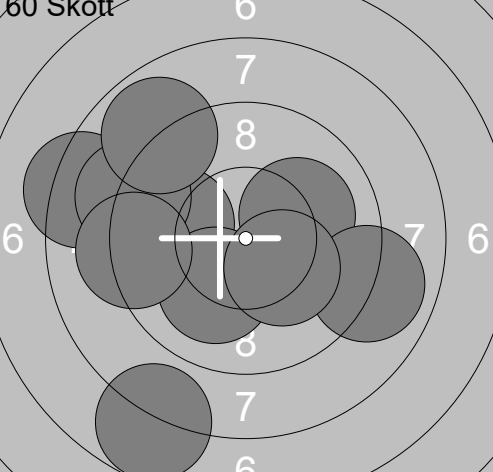
<p>60 Skott</p> 	<p>51: 7.8 ↓ 52: 9.9 ← 53: 8.3 ↖ 54: 9.1 ↖ 55: 10.1 ↓ 56: 10.1 → 57: 9.0 → 58: 9.2 ← 59: 8.9 ↗ 60: 10.2x ↓</p>		
Serie 92.6			
Total 562.8			

Prov 	1: 10.3 ✕ 2: 9.9 ↙ 3: 10.6 ✕ ↗ 4: 10.3 ✕ 5: 10.7 ✕	60 Skott 	1: 9.5 ← 2: 9.6 ↓ 3: 10.5 ✕ ↓ 4: 10.2 ✕ 5: 10.9 ✕ ↓ 6: 10.5 ✕ ↓ 7: 10.7 ✕ → 8: 9.7 ← 9: 10.1 ↙ 10: 10.5 ✕
Serie 49.0		Serie 97.0	
Total 0.0		Total 97.0	

60 Skott 	11: 10.8 ✕ 12: 10.7 ✕ 13: 10.8 ✕ → 14: 10.3 ✕ 15: 10.7 ✕ ↓ 16: 10.5 ✕ 17: 10.5 ✕ ↓ 18: 10.5 ✕ 19: 10.6 ✕ ↓ 20: 9.1 ←	60 Skott 	21: 10.7 ✕ 22: 10.1 → 23: 10.6 ✕ ↓ 24: 10.4 ✕ 25: 10.6 ✕ ↓ 26: 10.5 ✕ 27: 10.2 ✕ ↓ 28: 10.6 ✕ ↓ 29: 10.4 ✕ ↓ 30: 10.9 ✕ ↓
Serie 99.0		Serie 100.0	
Total 196.0		Total 296.0	

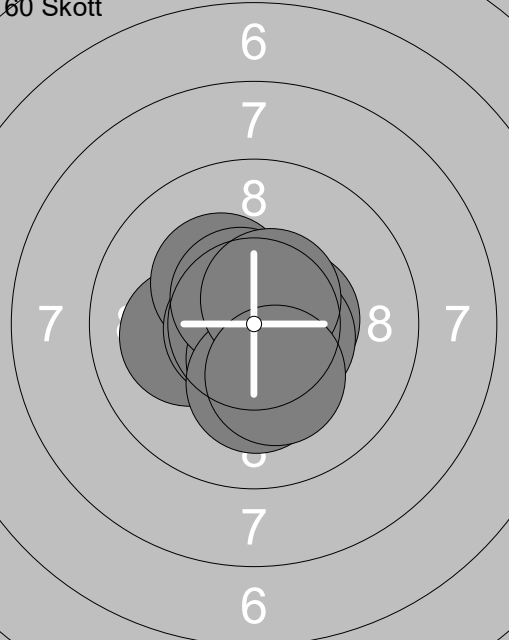
60 Skott 	31: 10.5 ✕ → 32: 10.1 ← 33: 10.3 ✕ 34: 10.7 ✕ 35: 10.5 ✕ ↓ 36: 10.6 ✕ 37: 10.2 ✕ ↓ 38: 10.5 ✕ → 39: 10.6 ✕ ↗ 40: 10.2 ✕ ↓		
Serie 100.0			
Total 396.0			

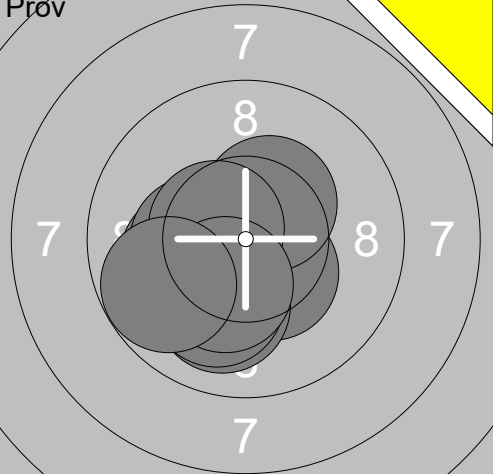
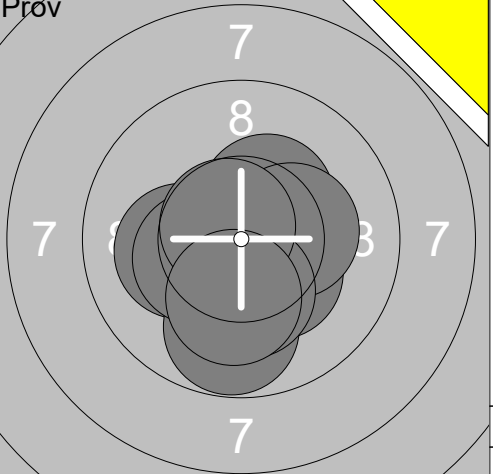
<p>Pröv</p> 	<p>1: 10.7x ↙ 2: 10.4x ↓ 3: 10.2x ← 4: 10.3x ← 5: 10.4x ↗ 6: 10.5x ← 7: 10.0 ↓ 8: 10.1 ↓ 9: 10.3x ↓ 10: 9.8 ←</p> <p>Serie 99.0 Total 0.0</p>	<p>Pröv</p> 	<p>11: 10.2x ← 12: 10.8x ← 13: 10.3x ↘ 14: 9.8 ↓ 15: 10.4x ↗ 16: 10.3x → 17: 10.3x ↓ 18: 10.4x ← 19: 10.7x ↖ 20: 10.2x ↓</p> <p>Serie 99.0 Total 0.0</p>
---	--	---	---

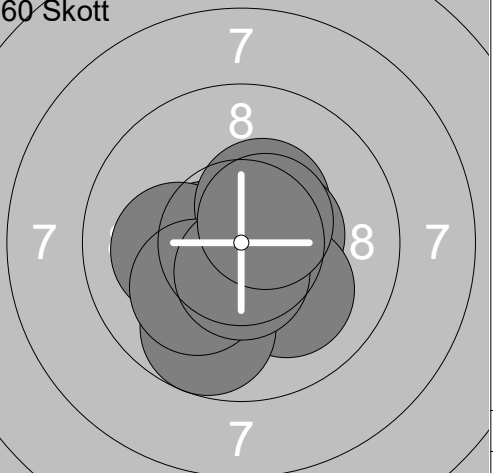
<p>Pröv</p> 	<p>21: 10.0 ↖ 22: 10.6x ←</p> <p>Serie 20.0 Total 0.0</p>	<p>60 Skott</p> 	<p>1: 10.5x ← 2: 10.1 ← 3: 10.4x ↗ 4: 10.4x ↓ 5: 10.5x → 6: 10.1 ↓ 7: 9.7 ↓ 8: 10.1 ↙ 9: 10.6x ↓ 10: 10.5x ↗</p> <p>Serie 99.0 Total 99.0</p>
--	---	--	--

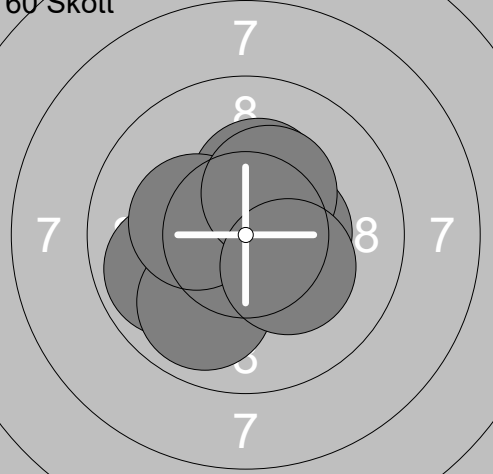
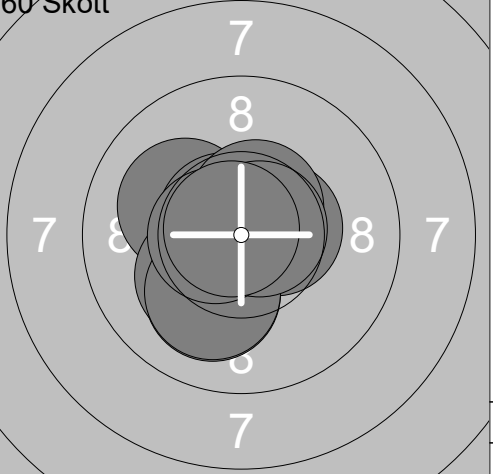
<p>60 Skott</p> 	<p>11: 10.7x ← 12: 10.2x ↙ 13: 10.3x ↗ 14: 9.9 ← 15: 10.4x ← 16: 9.9 ↓ 17: 10.4x → 18: 10.3x ← 19: 10.3x ↗ 20: 10.3x ↘</p> <p>Serie 98.0 Total 197.0</p>	<p>60 Skott</p> 	<p>21: 10.5x → 22: 10.1 ← 23: 10.1 ↓ 24: 10.7x ↖ 25: 10.5x ↗ 26: 10.2x ↙ 27: 10.1 ↓ 28: 10.7x → 29: 10.6x ← 30: 10.8x ↖</p> <p>Serie 100.0 Total 297.0</p>
---	---	---	---

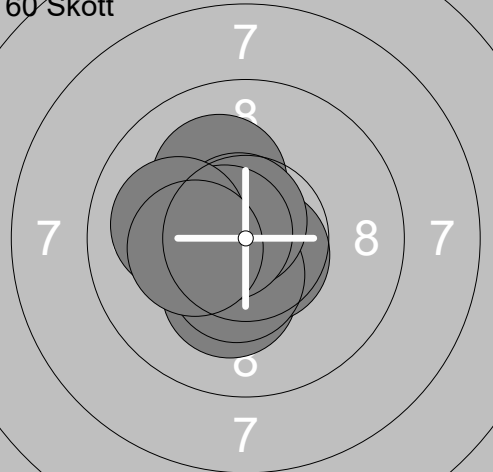
<p>60 Skott</p> 	<p>31: 10.2x ↓ 32: 10.8x ← 33: 10.7x ↘ 34: 10.4x ↗ 35: 10.5x ↓ 36: 10.1 ↗ 37: 10.7x ↗ 38: 10.7x ← 39: 10.0 ← 40: 10.3x ←</p> <p>Serie 100.0 Total 397.0</p>		
---	--	--	--

<p>Prov</p>	<p>1: 10.2x➤</p> <p>2: 9.5 ↘</p> <p>3: 10.6x↓</p> <p>4: 10.5x➤</p> <p>5: 10.7x↙</p> <p>6: 10.5x↔</p> <p>7: 10.5x➤</p> <p>8: 10.2x➤</p> <p>9: 10.3x↗</p> <p>10: 10.7x➤</p>	<p>Prov</p>	<p>11: 10.8x➤</p> <p>12: 10.6x↘</p> <p>13: 10.5x↓</p>
Serie 99.0	Total 0.0	Serie 30.0	Total 0.0

<p>60 Skott</p>	<p>1: 10.5x↗</p> <p>2: 10.4x↗</p> <p>3: 10.6x↔</p> <p>4: 10.1↙</p> <p>5: 10.6x↗</p> <p>6: 10.7x↙</p> <p>7: 10.5x↗</p> <p>8: 10.4x↔</p> <p>9: 10.8x↙</p> <p>10: 10.7x↙</p>	<p>60 Skott</p>	<p>11: 10.6x↙</p> <p>12: 10.6x↘</p> <p>13: 10.2x↗</p> <p>14: 10.4x↔</p> <p>15: 10.6x↓</p> <p>16: 10.5x↓</p> <p>17: 10.8x↘</p> <p>18: 10.5x↘</p> <p>19: 10.7x↔</p> <p>20: 10.4x↔</p>
Serie 100.0	Total 100.0	Serie 100.0	Total 200.0

<p>60 Skott</p>	<p>21: 10.6x↙</p> <p>22: 10.0 ↘</p> <p>23: 10.8x↔</p> <p>24: 10.4x↔</p> <p>25: 10.1↙</p> <p>26: 10.3x➤</p> <p>27: 10.7x↘</p> <p>28: 10.8x↘</p> <p>29: 10.8x➤</p> <p>30: 10.2x↗</p>	<p>60 Skott</p>	<p>31: 10.2x↓</p> <p>32: 10.7x↘</p> <p>33: 10.4x➤</p> <p>34: 10.3x↗</p> <p>35: 10.2x↗</p> <p>36: 10.4x↔</p> <p>37: 10.8x➤</p> <p>38: 10.1➤</p> <p>39: 10.6x↓</p> <p>40: 10.3x↗</p>
Serie 100.0	Total 300.0	Serie 100.0	Total 400.0

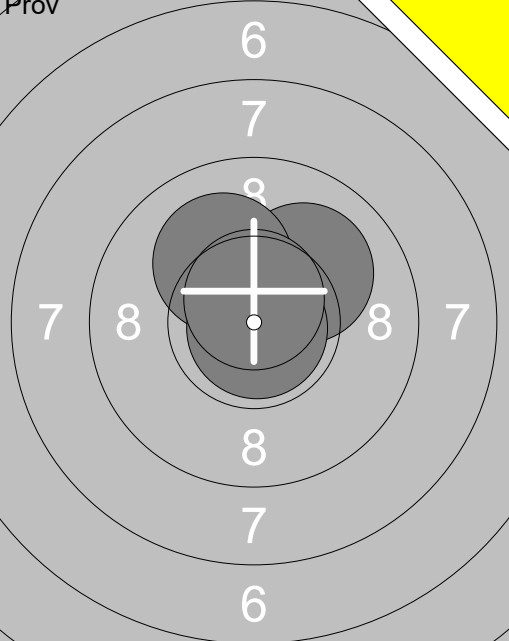
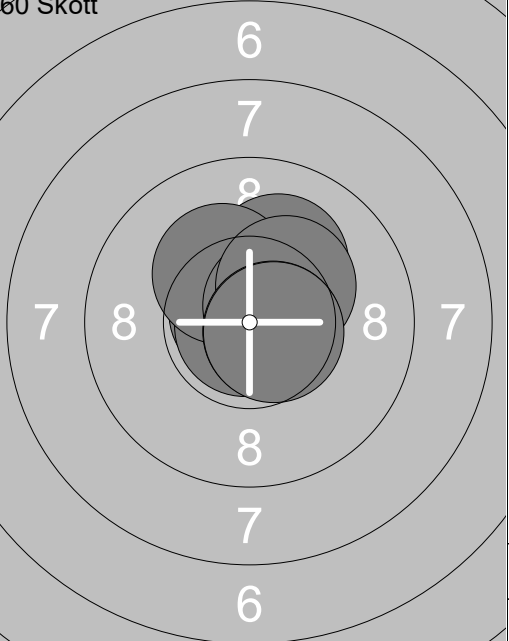
Prov 	1: 10.1 ↗ 2: 10.1 ↖ 3: 10.9x ↘ 4: 10.7x ↗	60 Skott 	1: 10.8x ↗ 2: 10.8x ↘ 3: 10.6x ↖ 4: 10.9x ↘ 5: 10.1 ↗ 6: 10.2x ↘ 7: 10.6x ↗ 8: 10.3x ↗ 9: 10.6x ↗ 10: 10.6x ↗
Serie	40.0	Serie	100.0
Total	0.0	Total	100.0

60 Skott 	11: 10.6x ↗ 12: 10.8x ↗ 13: 10.6x ↗ 14: 10.8x ↘ 15: 10.6x ↘ 16: 10.7x ↘ 17: 10.8x ↗ 18: 10.5x ↘ 19: 10.8x ↘ 20: 10.6x ↗	60 Skott 	21: 10.7x ↘ 22: 10.5x ↘ 23: 10.7x ↘ 24: 10.5x ↖ 25: 10.7x ↘ 26: 10.7x ↘ 27: 10.6x ↘ 28: 10.4x ↗ 29: 10.8x ↘ 30: 10.7x ↘
Serie	100.0	Serie	100.0
Total	200.0	Total	300.0

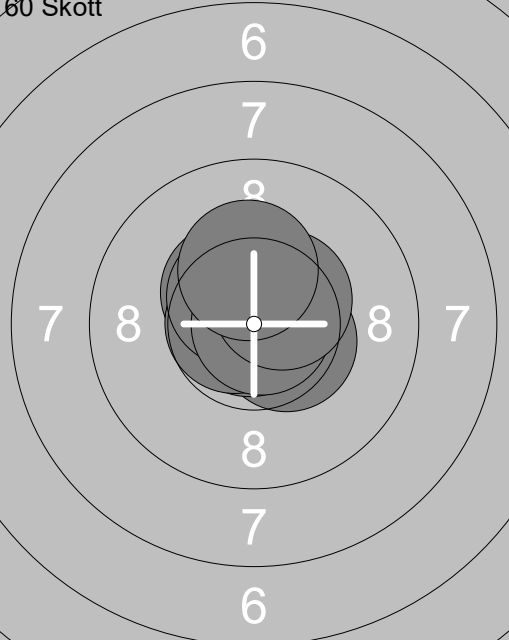
60 Skott 	31: 10.4x ↘ 32: 10.6x ↗ 33: 10.5x ↗ 34: 10.9x ↘ 35: 10.7x ↖ 36: 10.5x ↘ 37: 10.7x ↗ 38: 10.9x ↗ 39: 10.5x ↗ 40: 10.3x ↗		
Serie	100.0		
Total	400.0		

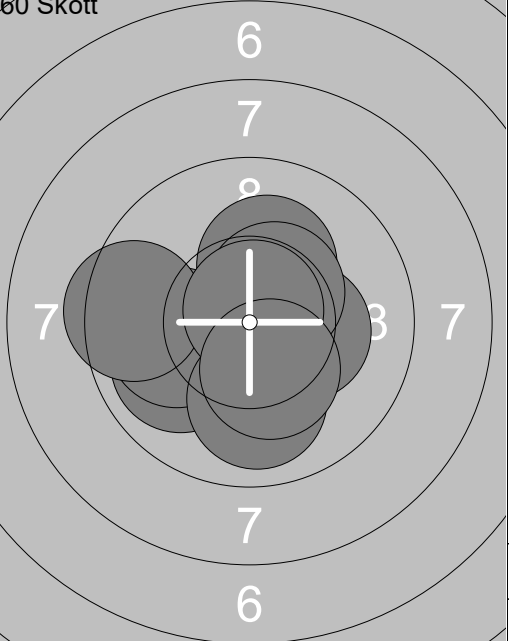

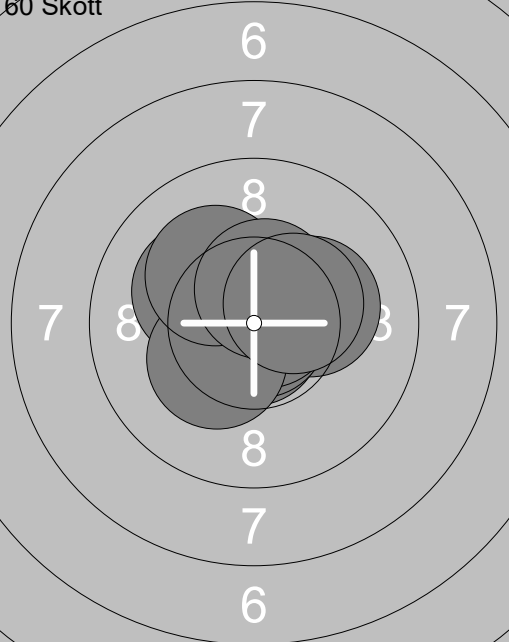
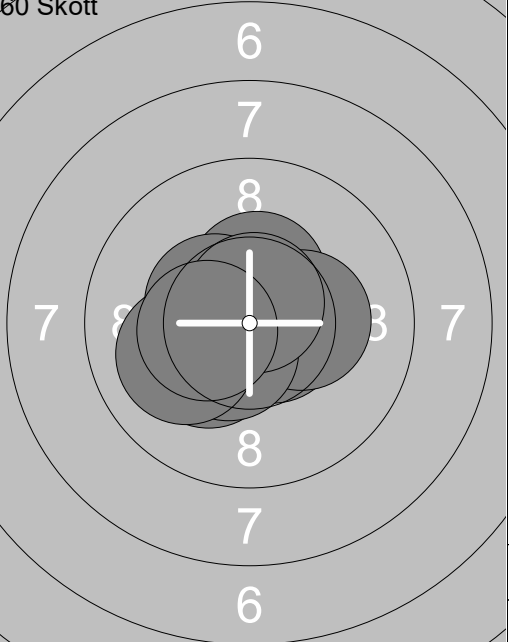
<p>Prov</p> 	<p>1: 9.2 ↘</p> <p>2: 10.4x➤</p> <p>3: 9.4 ↘</p> <p>4: 10.8x↙</p> <p>5: 9.8 ↘</p> <p>6: 10.8x↗</p> <p>7: 10.4x↙</p> <p>8: 10.6x↙</p> <p>9: 10.3x↙</p> <p>10: 10.5x↗</p>	<p>60 Skott</p> 		<p>1: 10.4x↘</p> <p>2: 10.3x➤</p> <p>3: 9.9 ↙</p> <p>4: 10.2x↗</p> <p>5: 10.4x↗</p> <p>6: 10.0↙</p> <p>7: 10.0 ↘</p> <p>8: 9.5 ↙</p> <p>9: 10.8x↗</p> <p>10: 10.3x↘</p>	
Serie	97.0			Serie	98.0
Total	0.0			Total	98.0

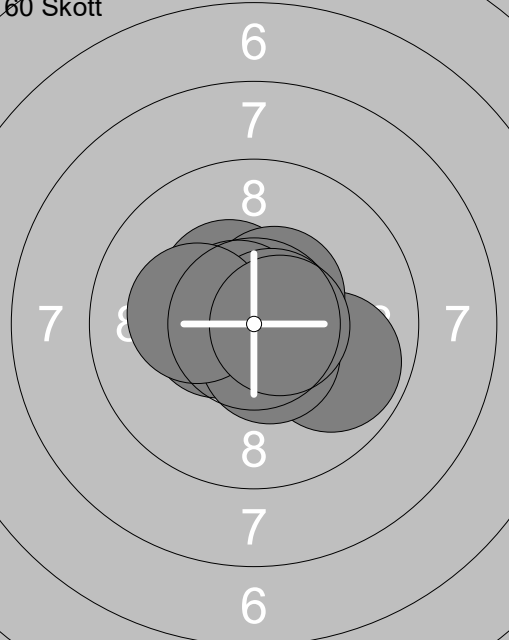
<p>60 Skott</p> 	<p>11: 10.2x➤</p> <p>12: 10.8x↘</p> <p>13: 10.2x↙</p> <p>14: 10.9x↘</p> <p>15: 10.8x➤</p> <p>16: 10.6x↙</p> <p>17: 10.3x↙</p> <p>18: 10.2x↙</p> <p>19: 10.5x↗</p> <p>20: 10.4x➤</p>	<p>60 Skott</p> 		<p>21: 10.4x↗</p> <p>22: 10.4x↙</p> <p>23: 10.6x➤</p> <p>24: 10.3x➤</p> <p>25: 10.4x↙</p> <p>26: 10.3x↙</p> <p>27: 10.5x↙</p> <p>28: 10.7x↗</p> <p>29: 10.1↙</p> <p>30: 10.4x↙</p>	
Serie	100.0			Serie	100.0
Total	198.0			Total	298.0

<p>60 Skott</p> 	<p>31: 10.4x↙</p> <p>32: 9.9 ➤</p> <p>33: 10.8x↗</p> <p>34: 10.5x↗</p> <p>35: 10.5x↙</p> <p>36: 10.7x↙</p> <p>37: 10.7x➤</p> <p>38: 10.5x↘</p> <p>39: 10.2x↙</p> <p>40: 10.6x➤</p>			
Serie	99.0			
Total	397.0			

<p>Prov</p> 	<p>60 Skott</p> 	<p>1: 10.0 →</p> <p>2: 10.6x ↘</p> <p>3: 10.3x ↗</p> <p>4: 10.3x ↘</p> <p>5: 10.5x ↗</p> <p>6: 10.8x ↘</p> <p>7: 10.2x →</p> <p>8: 10.5x ↘</p> <hr/> <p>Serie 80.0</p> <p>Total 0.0</p>	<p>1: 10.3x ↘</p> <p>2: 10.7x ↗</p> <p>3: 10.7x ↘</p> <p>4: 9.7 ↓</p> <p>5: 10.1 ←</p> <p>6: 10.4x ↘</p> <p>7: 10.6x ↘</p> <p>8: 10.5x →</p> <p>9: 10.5x ↘</p> <p>10: 10.6x ↗</p> <hr/> <p>Serie 99.0</p> <p>Total 99.0</p>
--	--	---	---

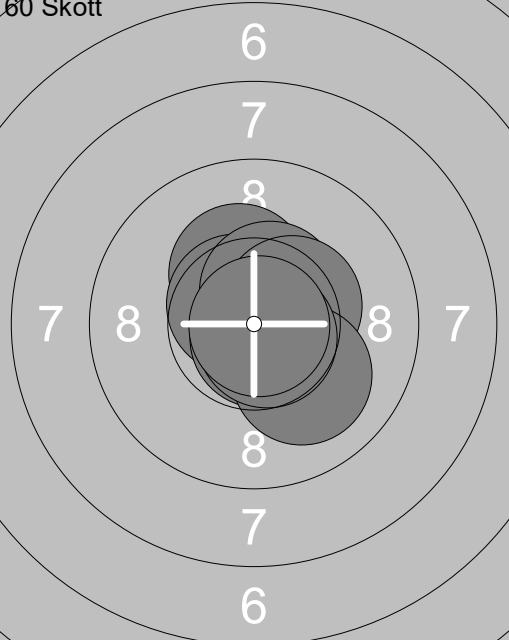
<p>60 Skott</p> 	<p>60 Skott</p> 	<p>11: 10.3x ↘</p> <p>12: 10.6x ↘</p> <p>13: 10.7x ↘</p> <p>14: 10.7x ↘</p> <p>15: 10.9x ↗</p> <p>16: 10.7x ↘</p> <p>17: 10.8x ↗</p> <p>18: 10.5x ↘</p> <p>19: 10.3x ↘</p> <p>20: 10.5x ↘</p> <hr/> <p>Serie 100.0</p> <p>Total 199.0</p>	<p>21: 10.7x ↘</p> <p>22: 10.8x ↘</p> <p>23: 10.6x ↘</p> <p>24: 10.8x ↘</p> <p>25: 10.4x ↘</p> <p>26: 10.0 ↓</p> <p>27: 10.6x ↗</p> <p>28: 10.6x ↘</p> <p>29: 10.5x ↘</p> <p>30: 10.7x ↘</p> <hr/> <p>Serie 100.0</p> <p>Total 299.0</p>
---	---	---	--

<p>60 Skott</p> 	<p>60 Skott</p> 	<p>31: 10.3x ↗</p> <p>32: 10.6x ↗</p> <p>33: 10.8x →</p> <p>34: 10.6x ↘</p> <p>35: 10.8x ↘</p> <p>36: 10.5x ↗</p> <p>37: 10.4x →</p> <p>38: 10.1 ↓</p> <p>39: 10.7x ↘</p> <p>40: 10.9x →</p> <hr/> <p>Serie 100.0</p> <p>Total 399.0</p>	<p>41: 10.3x ↘</p> <p>42: 10.7x ↗</p> <p>43: 10.7x ↘</p> <p>44: 9.7 ↓</p> <p>45: 10.1 ←</p> <p>46: 10.4x ↘</p> <p>47: 10.6x ↘</p> <p>48: 10.5x →</p> <p>49: 10.5x ↘</p> <p>50: 10.6x ↗</p> <hr/> <p>Serie 99.0</p> <p>Total 99.0</p>
--	--	--	--

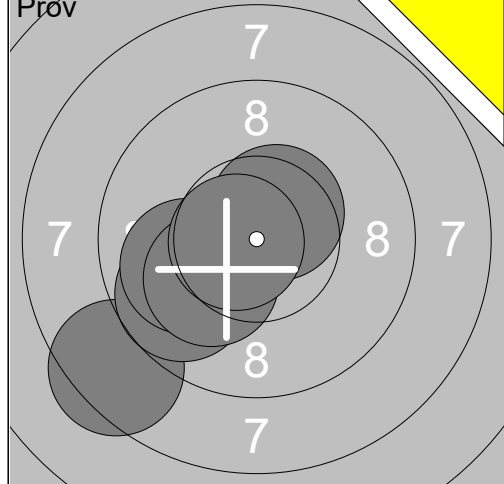

1:	8.4	↙
2:	9.7	↙
3:	10.0	↖
4:	10.2x	↙
5:	10.5x	↗
6:	10.7x	↖

Serie	59.5
Total	0.0

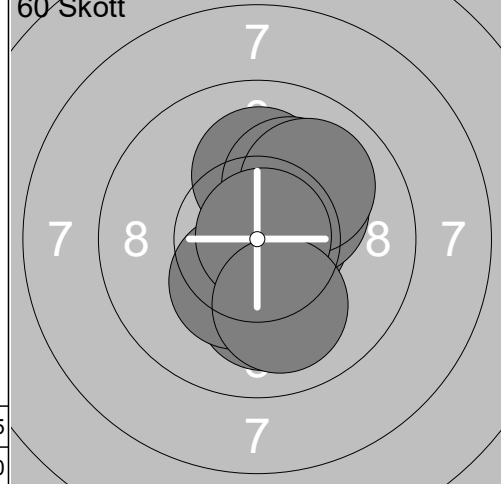

1:	10.4x	↗
2:	10.6x	→
3:	10.1	↑
4:	10.1	↗
5:	10.2x	↗
6:	10.1	↓
7:	10.0	↗
8:	10.3x	↓
9:	10.9x	↗
10:	10.0	↓

Serie	102.7
Total	102.7

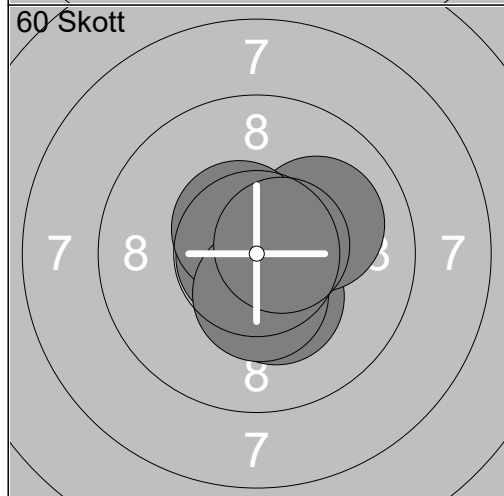

11:	10.7x	→
12:	10.8x	↖
13:	10.8x	↗
14:	10.7x	↘
15:	10.7x	↗
16:	10.3x	↓
17:	10.1	↗
18:	10.5x	↗
19:	10.4x	↓
20:	10.6x	→

Serie	105.6
Total	208.3

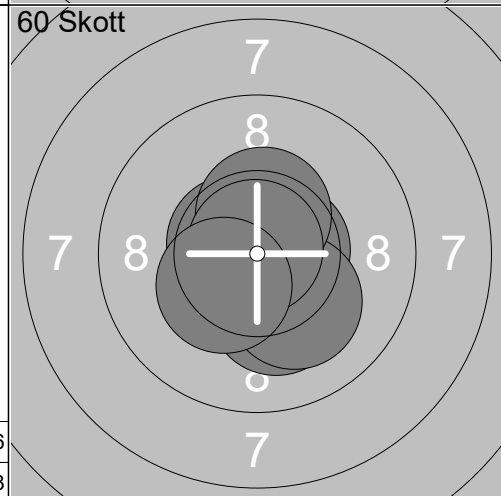

21:	10.5x	↓
22:	10.2x	↓
23:	10.5x	↑
24:	10.6x	→
25:	10.2x	↓
26:	10.7x	↖
27:	10.6x	↖
28:	10.4x	↑
29:	10.9x	↗
30:	10.3x	↙

Serie	104.9
Total	313.2

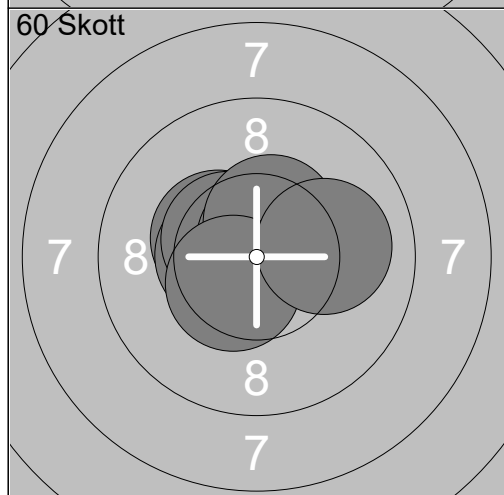

31:	10.8x	↖
32:	10.8x	↑
33:	10.6x	↗
34:	10.4x	↖
35:	10.5x	↖
36:	10.5x	↖
37:	10.7x	↗
38:	10.5x	↗
39:	10.5x	↙
40:	10.1	→

Serie	105.4
Total	418.6

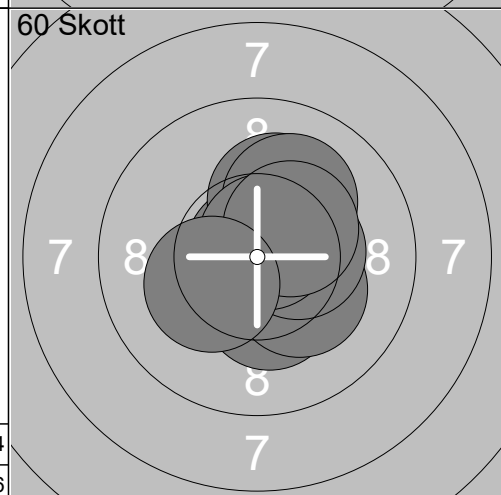

41:	10.9x	↖
42:	10.6x	↗
43:	10.3x	↓
44:	10.2x	↑
45:	10.1	↗
46:	10.2x	↘
47:	10.4x	→
48:	10.7x	↗
49:	10.4x	↗
50:	10.3x	↙

Serie	104.1
Total	522.7

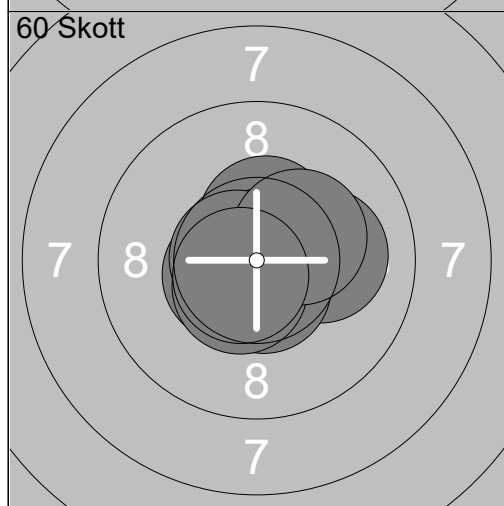

51:	10.8x	↙
52:	10.5x	↙
53:	10.1	→
54:	10.5x	↑
55:	10.9x	↗
56:	10.6x	↓
57:	10.7x	↖
58:	10.5x	↓
59:	10.3x	↗
60:	10.7x	↙

Serie	105.6
Total	628.3

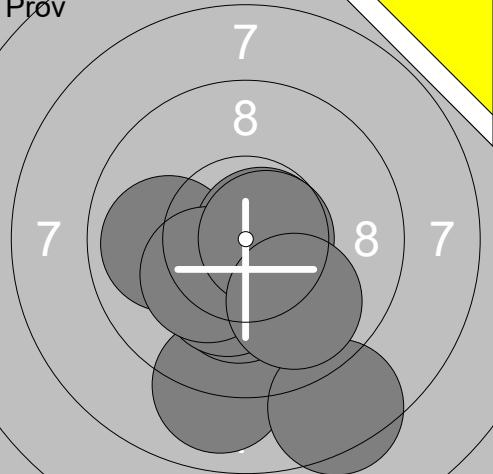
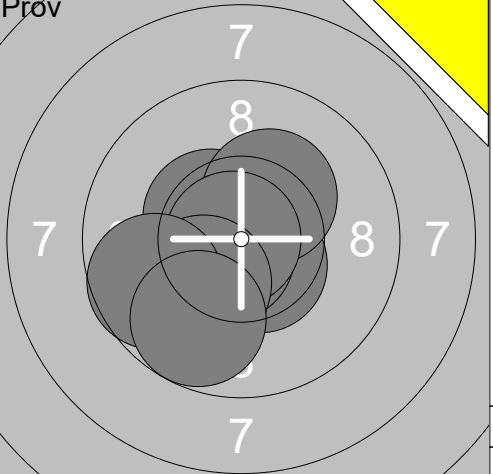
<p>Pröv</p> 	<table border="1" style="width:100%; border-collapse: collapse;"> <tr><td>1:</td><td>9.0</td><td>↓</td></tr> <tr><td>2:</td><td>9.9</td><td>←</td></tr> <tr><td>3:</td><td>10.2x</td><td>↓</td></tr> <tr><td>4:</td><td>10.4x</td><td>↓</td></tr> <tr><td>5:</td><td>10.3x</td><td>↓</td></tr> <tr><td>6:</td><td>8.4</td><td>↓</td></tr> <tr><td>7:</td><td>10.7x</td><td>→</td></tr> <tr><td>8:</td><td>10.3x</td><td>↙</td></tr> <tr><td>9:</td><td>10.7x</td><td>→</td></tr> <tr><td>10:</td><td>9.9</td><td>↓</td></tr> <tr><td colspan="2">Serie</td><td>95.0</td></tr> <tr><td colspan="2">Total</td><td>0.0</td></tr> </table>	1:	9.0	↓	2:	9.9	←	3:	10.2x	↓	4:	10.4x	↓	5:	10.3x	↓	6:	8.4	↓	7:	10.7x	→	8:	10.3x	↙	9:	10.7x	→	10:	9.9	↓	Serie		95.0	Total		0.0	<p>Pröv</p>  <table border="1" style="width:100%; border-collapse: collapse;"> <tr><td>11:</td><td>10.5x</td><td>↘</td></tr> <tr><td>12:</td><td>10.5x</td><td>←</td></tr> <tr><td>13:</td><td>10.5x</td><td>↖</td></tr> <tr><td>14:</td><td>10.7x</td><td>↙</td></tr> <tr><td>15:</td><td>10.3x</td><td>↗</td></tr> <tr><td>16:</td><td>10.8x</td><td>←</td></tr> <tr><td>17:</td><td>10.0</td><td>↓</td></tr> <tr><td>18:</td><td>10.2x</td><td>↙</td></tr> <tr><td>19:</td><td>9.7</td><td>←</td></tr> <tr><td>20:</td><td>9.8</td><td>↓</td></tr> <tr><td colspan="2">Serie</td><td>98.0</td></tr> <tr><td colspan="2">Total</td><td>0.0</td></tr> </table>	11:	10.5x	↘	12:	10.5x	←	13:	10.5x	↖	14:	10.7x	↙	15:	10.3x	↗	16:	10.8x	←	17:	10.0	↓	18:	10.2x	↙	19:	9.7	←	20:	9.8	↓	Serie		98.0	Total		0.0
1:	9.0	↓																																																																								
2:	9.9	←																																																																								
3:	10.2x	↓																																																																								
4:	10.4x	↓																																																																								
5:	10.3x	↓																																																																								
6:	8.4	↓																																																																								
7:	10.7x	→																																																																								
8:	10.3x	↙																																																																								
9:	10.7x	→																																																																								
10:	9.9	↓																																																																								
Serie		95.0																																																																								
Total		0.0																																																																								
11:	10.5x	↘																																																																								
12:	10.5x	←																																																																								
13:	10.5x	↖																																																																								
14:	10.7x	↙																																																																								
15:	10.3x	↗																																																																								
16:	10.8x	←																																																																								
17:	10.0	↓																																																																								
18:	10.2x	↙																																																																								
19:	9.7	←																																																																								
20:	9.8	↓																																																																								
Serie		98.0																																																																								
Total		0.0																																																																								

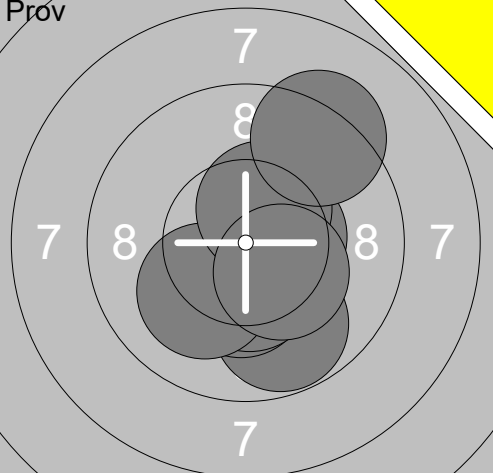
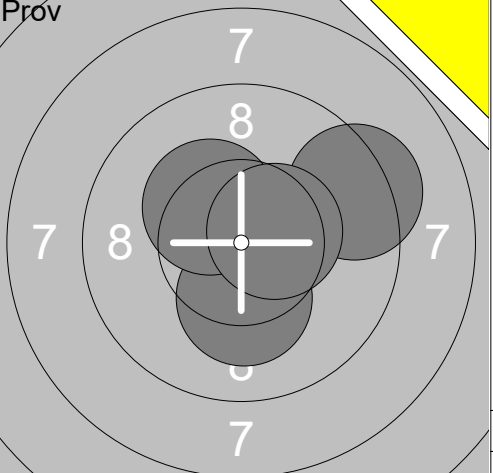
<p>Pröv</p> 	<table border="1" style="width:100%; border-collapse: collapse;"> <tr><td>21:</td><td>10.5x</td><td>↘</td></tr> <tr><td>22:</td><td>9.8</td><td>↓</td></tr> <tr><td>23:</td><td>10.5x</td><td>→</td></tr> <tr><td>24:</td><td>10.3x</td><td>↓</td></tr> <tr><td>25:</td><td>10.4x</td><td>↓</td></tr> <tr><td>26:</td><td>10.7x</td><td>↘</td></tr> <tr><td>27:</td><td>10.1</td><td>↙</td></tr> <tr><td>28:</td><td>10.4x</td><td>↗</td></tr> <tr><td>29:</td><td>9.3</td><td>↗</td></tr> <tr><td>30:</td><td>10.3x</td><td>↘</td></tr> <tr><td colspan="2">Serie</td><td>98.0</td></tr> <tr><td colspan="2">Total</td><td>0.0</td></tr> </table>	21:	10.5x	↘	22:	9.8	↓	23:	10.5x	→	24:	10.3x	↓	25:	10.4x	↓	26:	10.7x	↘	27:	10.1	↙	28:	10.4x	↗	29:	9.3	↗	30:	10.3x	↘	Serie		98.0	Total		0.0	<p>Pröv</p>  <table border="1" style="width:100%; border-collapse: collapse;"> <tr><td>31:</td><td>10.2x</td><td>↓</td></tr> <tr><td>32:</td><td>9.3</td><td>→</td></tr> <tr><td>33:</td><td>10.3x</td><td>↖</td></tr> <tr><td>34:</td><td>10.5x</td><td>→</td></tr> <tr><td colspan="2">Serie</td><td>39.0</td></tr> <tr><td colspan="2">Total</td><td>0.0</td></tr> </table>	31:	10.2x	↓	32:	9.3	→	33:	10.3x	↖	34:	10.5x	→	Serie		39.0	Total		0.0
21:	10.5x	↘																																																						
22:	9.8	↓																																																						
23:	10.5x	→																																																						
24:	10.3x	↓																																																						
25:	10.4x	↓																																																						
26:	10.7x	↘																																																						
27:	10.1	↙																																																						
28:	10.4x	↗																																																						
29:	9.3	↗																																																						
30:	10.3x	↘																																																						
Serie		98.0																																																						
Total		0.0																																																						
31:	10.2x	↓																																																						
32:	9.3	→																																																						
33:	10.3x	↖																																																						
34:	10.5x	→																																																						
Serie		39.0																																																						
Total		0.0																																																						

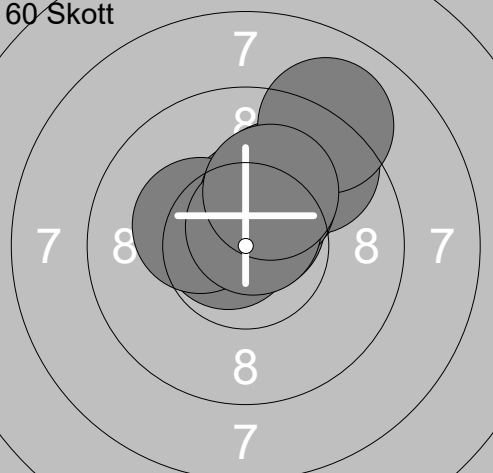
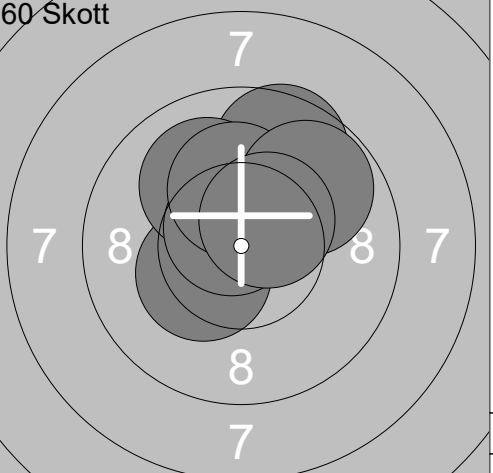
<p>60 Skott</p> 	<table border="1" style="width:100%; border-collapse: collapse;"> <tr><td>1:</td><td>10.1</td><td>↗</td></tr> <tr><td>2:</td><td>10.7x</td><td>←</td></tr> <tr><td>3:</td><td>10.4x</td><td>↑</td></tr> <tr><td>4:</td><td>9.6</td><td>↗</td></tr> <tr><td>5:</td><td>10.6x</td><td>↗</td></tr> <tr><td>6:</td><td>10.3x</td><td>←</td></tr> <tr><td>7:</td><td>10.3x</td><td>↗</td></tr> <tr><td>8:</td><td>10.7x</td><td>↗</td></tr> <tr><td>9:</td><td>9.0</td><td>↗</td></tr> <tr><td>10:</td><td>10.2x</td><td>↗</td></tr> <tr><td colspan="2">Serie</td><td>98.0</td></tr> <tr><td colspan="2">Total</td><td>98.0</td></tr> </table>	1:	10.1	↗	2:	10.7x	←	3:	10.4x	↑	4:	9.6	↗	5:	10.6x	↗	6:	10.3x	←	7:	10.3x	↗	8:	10.7x	↗	9:	9.0	↗	10:	10.2x	↗	Serie		98.0	Total		98.0	<p>60 Skott</p>  <table border="1" style="width:100%; border-collapse: collapse;"> <tr><td>11:</td><td>9.8</td><td>↗</td></tr> <tr><td>12:</td><td>10.3x</td><td>↙</td></tr> <tr><td>13:</td><td>9.6</td><td>↗</td></tr> <tr><td>14:</td><td>10.5x</td><td>↑</td></tr> <tr><td>15:</td><td>10.5x</td><td>↗</td></tr> <tr><td>16:</td><td>10.0</td><td>↖</td></tr> <tr><td>17:</td><td>10.7x</td><td>↖</td></tr> <tr><td>18:</td><td>10.2x</td><td>↑</td></tr> <tr><td>19:</td><td>9.8</td><td>↗</td></tr> <tr><td>20:</td><td>10.5x</td><td>↗</td></tr> <tr><td colspan="2">Serie</td><td>97.0</td></tr> <tr><td colspan="2">Total</td><td>195.0</td></tr> </table>	11:	9.8	↗	12:	10.3x	↙	13:	9.6	↗	14:	10.5x	↑	15:	10.5x	↗	16:	10.0	↖	17:	10.7x	↖	18:	10.2x	↑	19:	9.8	↗	20:	10.5x	↗	Serie		97.0	Total		195.0
1:	10.1	↗																																																																								
2:	10.7x	←																																																																								
3:	10.4x	↑																																																																								
4:	9.6	↗																																																																								
5:	10.6x	↗																																																																								
6:	10.3x	←																																																																								
7:	10.3x	↗																																																																								
8:	10.7x	↗																																																																								
9:	9.0	↗																																																																								
10:	10.2x	↗																																																																								
Serie		98.0																																																																								
Total		98.0																																																																								
11:	9.8	↗																																																																								
12:	10.3x	↙																																																																								
13:	9.6	↗																																																																								
14:	10.5x	↑																																																																								
15:	10.5x	↗																																																																								
16:	10.0	↖																																																																								
17:	10.7x	↖																																																																								
18:	10.2x	↑																																																																								
19:	9.8	↗																																																																								
20:	10.5x	↗																																																																								
Serie		97.0																																																																								
Total		195.0																																																																								

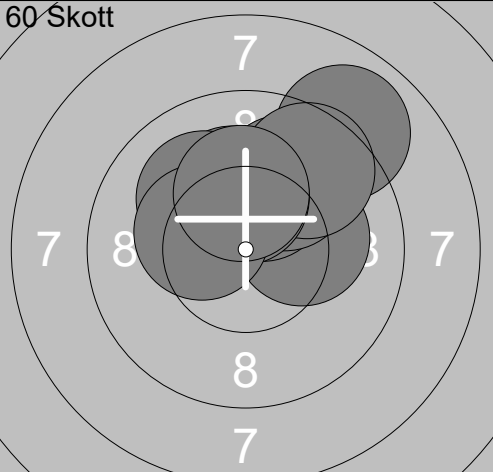
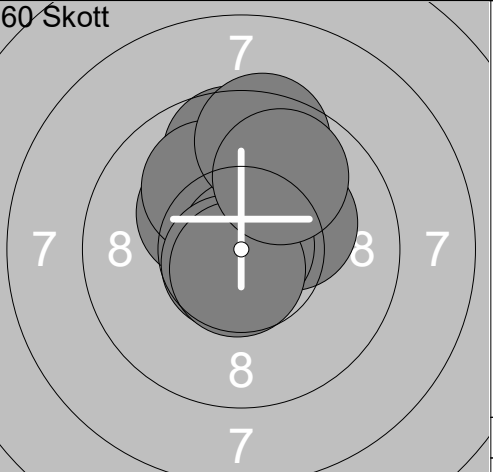
<p>60 Skott</p> 	<table border="1" style="width:100%; border-collapse: collapse;"> <tr><td>21:</td><td>10.2x</td><td>↑</td></tr> <tr><td>22:</td><td>10.2x</td><td>→</td></tr> <tr><td>23:</td><td>10.1</td><td>↖</td></tr> <tr><td>24:</td><td>10.2x</td><td>↑</td></tr> <tr><td>25:</td><td>9.9</td><td>↗</td></tr> <tr><td>26:</td><td>9.0</td><td>↗</td></tr> <tr><td>27:</td><td>9.6</td><td>↗</td></tr> <tr><td>28:</td><td>10.3x</td><td>↑</td></tr> <tr><td>29:</td><td>10.3x</td><td>←</td></tr> <tr><td>30:</td><td>10.2x</td><td>↑</td></tr> <tr><td colspan="2">Serie</td><td>97.0</td></tr> <tr><td colspan="2">Total</td><td>292.0</td></tr> </table>	21:	10.2x	↑	22:	10.2x	→	23:	10.1	↖	24:	10.2x	↑	25:	9.9	↗	26:	9.0	↗	27:	9.6	↗	28:	10.3x	↑	29:	10.3x	←	30:	10.2x	↑	Serie		97.0	Total		292.0	<p>60 Skott</p>  <table border="1" style="width:100%; border-collapse: collapse;"> <tr><td>31:</td><td>10.3x</td><td>↖</td></tr> <tr><td>32:</td><td>10.6x</td><td>↑</td></tr> <tr><td>33:</td><td>9.7</td><td>↑</td></tr> <tr><td>34:</td><td>10.0</td><td>↖</td></tr> <tr><td>35:</td><td>10.2x</td><td>→</td></tr> <tr><td>36:</td><td>10.9x</td><td>↗</td></tr> <tr><td>37:</td><td>10.7x</td><td>↙</td></tr> <tr><td>38:</td><td>9.5</td><td>↑</td></tr> <tr><td>39:</td><td>10.7x</td><td>↓</td></tr> <tr><td>40:</td><td>9.9</td><td>↗</td></tr> <tr><td colspan="2">Serie</td><td>97.0</td></tr> <tr><td colspan="2">Total</td><td>389.0</td></tr> </table>	31:	10.3x	↖	32:	10.6x	↑	33:	9.7	↑	34:	10.0	↖	35:	10.2x	→	36:	10.9x	↗	37:	10.7x	↙	38:	9.5	↑	39:	10.7x	↓	40:	9.9	↗	Serie		97.0	Total		389.0
21:	10.2x	↑																																																																								
22:	10.2x	→																																																																								
23:	10.1	↖																																																																								
24:	10.2x	↑																																																																								
25:	9.9	↗																																																																								
26:	9.0	↗																																																																								
27:	9.6	↗																																																																								
28:	10.3x	↑																																																																								
29:	10.3x	←																																																																								
30:	10.2x	↑																																																																								
Serie		97.0																																																																								
Total		292.0																																																																								
31:	10.3x	↖																																																																								
32:	10.6x	↑																																																																								
33:	9.7	↑																																																																								
34:	10.0	↖																																																																								
35:	10.2x	→																																																																								
36:	10.9x	↗																																																																								
37:	10.7x	↙																																																																								
38:	9.5	↑																																																																								
39:	10.7x	↓																																																																								
40:	9.9	↗																																																																								
Serie		97.0																																																																								
Total		389.0																																																																								

<p>Prov</p> 	<p>60 Skott</p> 	<p>1: 8.8 →</p> <p>2: 10.4x→</p> <p>3: 9.4 ↓</p> <p>4: 9.4 ↓</p> <p>5: 9.7 →</p> <p>6: 10.5x↖</p> <p>7: 10.4x↗</p> <p>8: 9.7 ↙</p> <p>9: 9.9 ↙</p> <p>10: 8.2 ↗</p> <hr/> <p>Serie 91.0</p> <hr/> <p>Total 0.0</p>	<p>1: 10.4x↖</p> <p>2: 9.4 ↓</p> <p>3: 9.0 ←</p> <p>4: 9.3 ↙</p> <p>5: 10.5x↗</p> <p>6: 9.5 ↓</p> <p>7: 9.3 ←</p> <p>8: 9.2 ↙</p> <p>9: 10.2x↓</p> <p>10: 8.4 ←</p> <hr/> <p>Serie 92.0</p> <hr/> <p>Total 92.0</p>
--	--	--	---

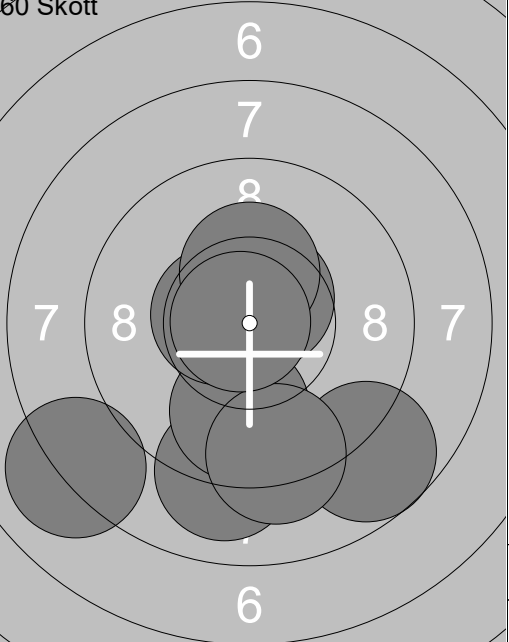
<p>60 Skott</p> 	<p>60 Skott</p> 	<p>11: 9.7 →</p> <p>12: 10.1 ↙</p> <p>13: 9.2 ↗</p> <p>14: 9.2 ←</p> <p>15: 9.8 ↗</p> <p>16: 10.2x↖</p> <p>17: 7.7 →</p> <p>18: 10.0 ↓</p> <p>19: 9.6 ↙</p> <p>20: 10.2x↗</p> <hr/> <p>Serie 92.0</p> <hr/> <p>Total 184.0</p>	<p>21: 10.7x↖</p> <p>22: 9.0 ↓</p> <p>23: 8.7 ↓</p> <p>24: 8.1 ↙</p> <p>25: 9.8 ↓</p> <p>26: 10.6x↗</p> <p>27: 10.6x↖</p> <p>28: 10.3x↗</p> <p>29: 9.2 ↓</p> <p>30: 10.8x↖</p> <hr/> <p>Serie 93.0</p> <hr/> <p>Total 277.0</p>
---	---	--	---

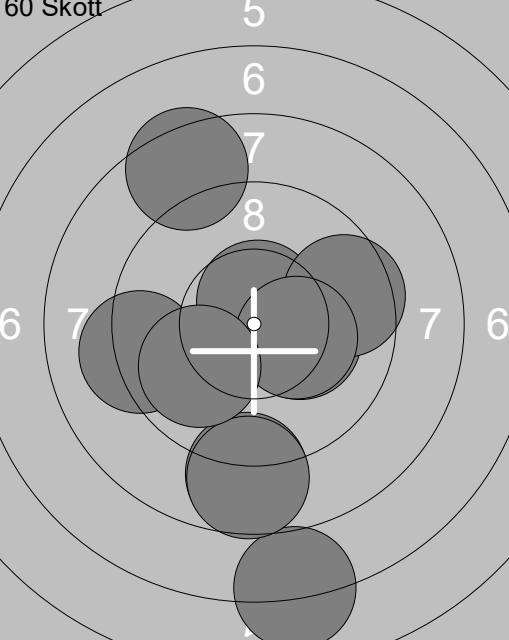
<p>60 Skott</p> 	<p>31: 10.6x↗</p> <p>32: 9.2 ←</p> <p>33: 10.2x→</p> <p>34: 8.7 ↓</p> <p>35: 7.0 ↓</p> <p>36: 9.6 →</p> <p>37: 10.3x→</p> <p>38: 8.5 ↗</p> <p>39: 8.7 ↓</p> <p>40: 9.9 ↙</p> <hr/> <p>Serie 88.0</p> <hr/> <p>Total 365.0</p>		
--	---	--	--

<p>Prov</p>	<table border="1" style="width:100%; border-collapse: collapse;"> <tr><td>1:</td><td>6.7</td><td>↙</td></tr> <tr><td>2:</td><td>9.8</td><td>↓</td></tr> <tr><td>3:</td><td>9.1</td><td>↓</td></tr> <tr><td>4:</td><td>7.2</td><td>↙</td></tr> <tr><td>5:</td><td>8.8</td><td>↓</td></tr> <tr><td>6:</td><td>10.4x</td><td>↓</td></tr> <tr><td>7:</td><td>10.1</td><td>→</td></tr> <tr><td>8:</td><td>9.2</td><td>↘</td></tr> <tr><td>9:</td><td>9.2</td><td>↘</td></tr> <tr><td>10:</td><td>10.2x</td><td>↗</td></tr> <tr><td colspan="2">Serie</td><td style="text-align: right;">87.0</td></tr> <tr><td colspan="2">Total</td><td style="text-align: right;">0.0</td></tr> </table>	1:	6.7	↙	2:	9.8	↓	3:	9.1	↓	4:	7.2	↙	5:	8.8	↓	6:	10.4x	↓	7:	10.1	→	8:	9.2	↘	9:	9.2	↘	10:	10.2x	↗	Serie		87.0	Total		0.0	<p>Prov</p>	<table border="1" style="width:100%; border-collapse: collapse;"> <tr><td>11:</td><td>9.7</td><td>↘</td></tr> <tr><td>12:</td><td>10.1</td><td>↘</td></tr> <tr><td>13:</td><td>9.3</td><td>↗</td></tr> <tr><td>14:</td><td>9.5</td><td>↓</td></tr> <tr><td>15:</td><td>9.8</td><td>↓</td></tr> <tr><td>16:</td><td>7.4</td><td>↙</td></tr> <tr><td>17:</td><td>10.4x</td><td>←</td></tr> <tr><td>18:</td><td>9.9</td><td>↖</td></tr> <tr><td>19:</td><td>9.8</td><td>↗</td></tr> <tr><td>20:</td><td>9.8</td><td>↘</td></tr> <tr><td colspan="2">Serie</td><td style="text-align: right;">90.0</td></tr> <tr><td colspan="2">Total</td><td style="text-align: right;">0.0</td></tr> </table>	11:	9.7	↘	12:	10.1	↘	13:	9.3	↗	14:	9.5	↓	15:	9.8	↓	16:	7.4	↙	17:	10.4x	←	18:	9.9	↖	19:	9.8	↗	20:	9.8	↘	Serie		90.0	Total		0.0
1:	6.7	↙																																																																									
2:	9.8	↓																																																																									
3:	9.1	↓																																																																									
4:	7.2	↙																																																																									
5:	8.8	↓																																																																									
6:	10.4x	↓																																																																									
7:	10.1	→																																																																									
8:	9.2	↘																																																																									
9:	9.2	↘																																																																									
10:	10.2x	↗																																																																									
Serie		87.0																																																																									
Total		0.0																																																																									
11:	9.7	↘																																																																									
12:	10.1	↘																																																																									
13:	9.3	↗																																																																									
14:	9.5	↓																																																																									
15:	9.8	↓																																																																									
16:	7.4	↙																																																																									
17:	10.4x	←																																																																									
18:	9.9	↖																																																																									
19:	9.8	↗																																																																									
20:	9.8	↘																																																																									
Serie		90.0																																																																									
Total		0.0																																																																									

<p>Prov</p>	<table border="1" style="width:100%; border-collapse: collapse;"> <tr><td>21:</td><td>10.1</td><td>↙</td></tr> <tr><td colspan="2">Serie</td><td style="text-align: right;">10.0</td></tr> <tr><td colspan="2">Total</td><td style="text-align: right;">0.0</td></tr> </table>	21:	10.1	↙	Serie		10.0	Total		0.0	<p>60 Skott</p>	<table border="1" style="width:100%; border-collapse: collapse;"> <tr><td>1:</td><td>10.3x</td><td>↓</td></tr> <tr><td>2:</td><td>10.0</td><td>↙</td></tr> <tr><td>3:</td><td>9.1</td><td>↗</td></tr> <tr><td>4:</td><td>7.8</td><td>←</td></tr> <tr><td>5:</td><td>9.7</td><td>↙</td></tr> <tr><td>6:</td><td>9.6</td><td>↗</td></tr> <tr><td>7:</td><td>9.3</td><td>↗</td></tr> <tr><td>8:</td><td>10.0</td><td>→</td></tr> <tr><td>9:</td><td>8.4</td><td>↗</td></tr> <tr><td>10:</td><td>9.6</td><td>↖</td></tr> <tr><td colspan="2">Serie</td><td style="text-align: right;">90.0</td></tr> <tr><td colspan="2">Total</td><td style="text-align: right;">90.0</td></tr> </table>	1:	10.3x	↓	2:	10.0	↙	3:	9.1	↗	4:	7.8	←	5:	9.7	↙	6:	9.6	↗	7:	9.3	↗	8:	10.0	→	9:	8.4	↗	10:	9.6	↖	Serie		90.0	Total		90.0
21:	10.1	↙																																														
Serie		10.0																																														
Total		0.0																																														
1:	10.3x	↓																																														
2:	10.0	↙																																														
3:	9.1	↗																																														
4:	7.8	←																																														
5:	9.7	↙																																														
6:	9.6	↗																																														
7:	9.3	↗																																														
8:	10.0	→																																														
9:	8.4	↗																																														
10:	9.6	↖																																														
Serie		90.0																																														
Total		90.0																																														

<p>60 Skott</p>	<table border="1" style="width:100%; border-collapse: collapse;"> <tr><td>11:</td><td>9.9</td><td>↘</td></tr> <tr><td>12:</td><td>9.3</td><td>↗</td></tr> <tr><td>13:</td><td>10.3x</td><td>↗</td></tr> <tr><td>14:</td><td>10.7x</td><td>↓</td></tr> <tr><td>15:</td><td>8.8</td><td>↗</td></tr> <tr><td>16:</td><td>9.4</td><td>↗</td></tr> <tr><td>17:</td><td>10.0</td><td>↓</td></tr> <tr><td>18:</td><td>10.2x</td><td>←</td></tr> <tr><td>19:</td><td>10.1</td><td>↖</td></tr> <tr><td>20:</td><td>10.1</td><td>↑</td></tr> <tr><td colspan="2">Serie</td><td style="text-align: right;">95.0</td></tr> <tr><td colspan="2">Total</td><td style="text-align: right;">185.0</td></tr> </table>	11:	9.9	↘	12:	9.3	↗	13:	10.3x	↗	14:	10.7x	↓	15:	8.8	↗	16:	9.4	↗	17:	10.0	↓	18:	10.2x	←	19:	10.1	↖	20:	10.1	↑	Serie		95.0	Total		185.0	<p>60 Skott</p>	<table border="1" style="width:100%; border-collapse: collapse;"> <tr><td>21:</td><td>8.5</td><td>→</td></tr> <tr><td>22:</td><td>9.9</td><td>↑</td></tr> <tr><td>23:</td><td>9.8</td><td>↑</td></tr> <tr><td>24:</td><td>10.6x</td><td>↓</td></tr> <tr><td>25:</td><td>10.0</td><td>↑</td></tr> <tr><td>26:</td><td>10.2x</td><td>↖</td></tr> <tr><td>27:</td><td>9.9</td><td>↗</td></tr> <tr><td>28:</td><td>8.0</td><td>↗</td></tr> <tr><td>29:</td><td>8.8</td><td>↑</td></tr> <tr><td>30:</td><td>10.0</td><td>↗</td></tr> <tr><td colspan="2">Serie</td><td style="text-align: right;">91.0</td></tr> <tr><td colspan="2">Total</td><td style="text-align: right;">276.0</td></tr> </table>	21:	8.5	→	22:	9.9	↑	23:	9.8	↑	24:	10.6x	↓	25:	10.0	↑	26:	10.2x	↖	27:	9.9	↗	28:	8.0	↗	29:	8.8	↑	30:	10.0	↗	Serie		91.0	Total		276.0
11:	9.9	↘																																																																									
12:	9.3	↗																																																																									
13:	10.3x	↗																																																																									
14:	10.7x	↓																																																																									
15:	8.8	↗																																																																									
16:	9.4	↗																																																																									
17:	10.0	↓																																																																									
18:	10.2x	←																																																																									
19:	10.1	↖																																																																									
20:	10.1	↑																																																																									
Serie		95.0																																																																									
Total		185.0																																																																									
21:	8.5	→																																																																									
22:	9.9	↑																																																																									
23:	9.8	↑																																																																									
24:	10.6x	↓																																																																									
25:	10.0	↑																																																																									
26:	10.2x	↖																																																																									
27:	9.9	↗																																																																									
28:	8.0	↗																																																																									
29:	8.8	↑																																																																									
30:	10.0	↗																																																																									
Serie		91.0																																																																									
Total		276.0																																																																									

<p>60 Skott</p>	<table border="1" style="width:100%; border-collapse: collapse;"> <tr><td>31:</td><td>10.0</td><td>↗</td></tr> <tr><td>32:</td><td>8.6</td><td>↗</td></tr> <tr><td>33:</td><td>8.5</td><td>↑</td></tr> <tr><td>34:</td><td>9.8</td><td>←</td></tr> <tr><td>35:</td><td>9.1</td><td>→</td></tr> <tr><td>36:</td><td>9.3</td><td>↘</td></tr> <tr><td>37:</td><td>9.1</td><td>↘</td></tr> <tr><td>38:</td><td>7.4</td><td>↗</td></tr> <tr><td>39:</td><td>8.5</td><td>→</td></tr> <tr><td>40:</td><td>10.7x</td><td>↓</td></tr> <tr><td colspan="2">Serie</td><td style="text-align: right;">87.0</td></tr> <tr><td colspan="2">Total</td><td style="text-align: right;">363.0</td></tr> </table>	31:	10.0	↗	32:	8.6	↗	33:	8.5	↑	34:	9.8	←	35:	9.1	→	36:	9.3	↘	37:	9.1	↘	38:	7.4	↗	39:	8.5	→	40:	10.7x	↓	Serie		87.0	Total		363.0		
31:	10.0	↗																																					
32:	8.6	↗																																					
33:	8.5	↑																																					
34:	9.8	←																																					
35:	9.1	→																																					
36:	9.3	↘																																					
37:	9.1	↘																																					
38:	7.4	↗																																					
39:	8.5	→																																					
40:	10.7x	↓																																					
Serie		87.0																																					
Total		363.0																																					

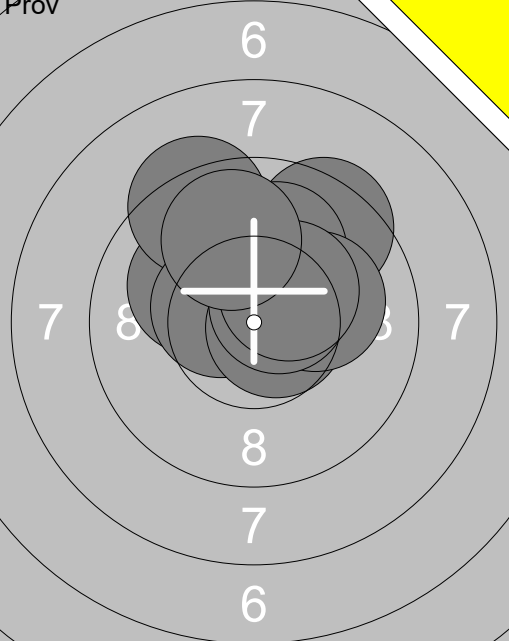
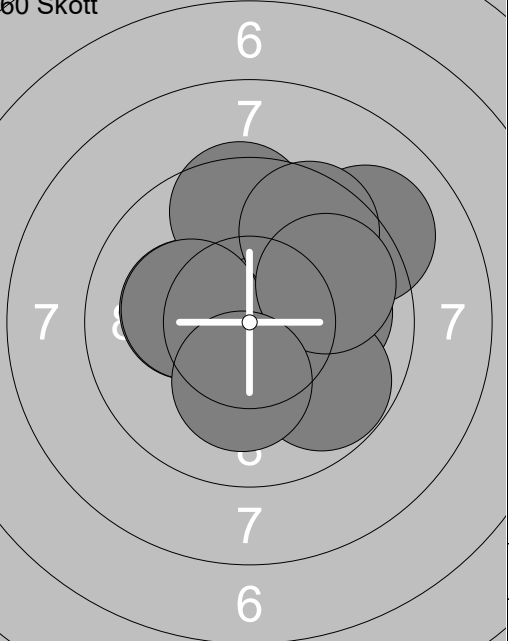
Prov 	1: 10.1 ↖ 2: 9.3 ↖ 3: 9.4 ↗ 4: 10.5 ✖ 5: 10.0 ↗ 6: 10.7 ✖➤ 7: 10.1 ➔ 8: 10.6 ✖↗ 9: 10.4 ✖↗ 10: 9.9 ↗ Serie 97.0 Total 0.0	60 Skott 		1: 10.2 ✖↖ 2: 9.5 ↗ 3: 10.8 ✖➤ 4: 10.0 ➔ 5: 9.1 ↗ 6: 10.2 ✖↖ 7: 9.8 ↘ 8: 9.6 ↗ 9: 9.9 ↗ 10: 10.2 ✖↓ Serie 95.0 Total 95.0
--	--	--	--	--

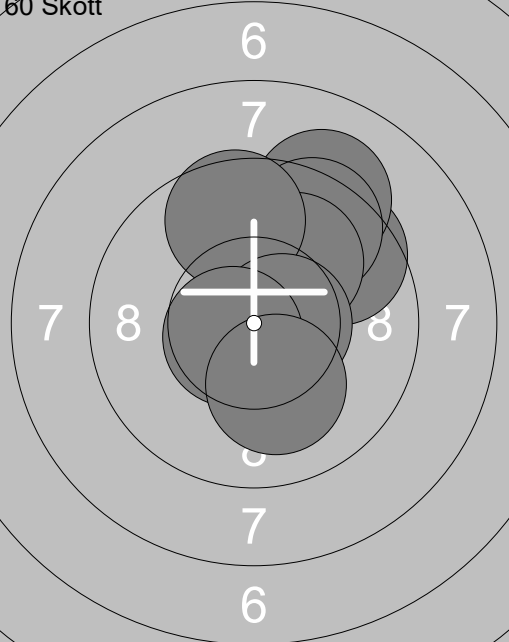
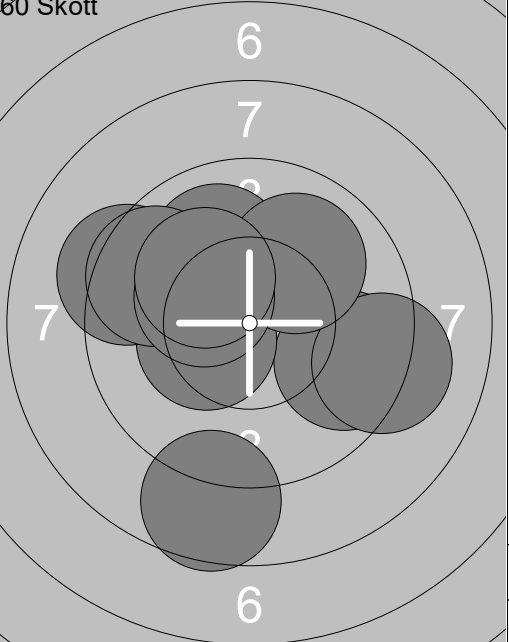
60 Skott 	11: 9.6 ↗ 12: 10.8 ✖↗ 13: 9.2 ↗ 14: 9.8 ↗ 15: 9.5 ↗ 16: 10.0 ↗ 17: 9.6 ↗ 18: 10.6 ✖➤ 19: 10.6 ✖↖ 20: 10.1 ↓ Serie 95.0 Total 190.0	60 Skott 		21: 8.6 ↓ 22: 10.0 ↖ 23: 9.7 ➔ 24: 10.4 ✖↖ 25: 9.2 ➔ 26: 9.3 ↖ 27: 10.0 ↗ 28: 9.6 ↖ 29: 10.3 ✖↖ 30: 10.1 ↖ Serie 94.0 Total 284.0
---	---	---	--	--

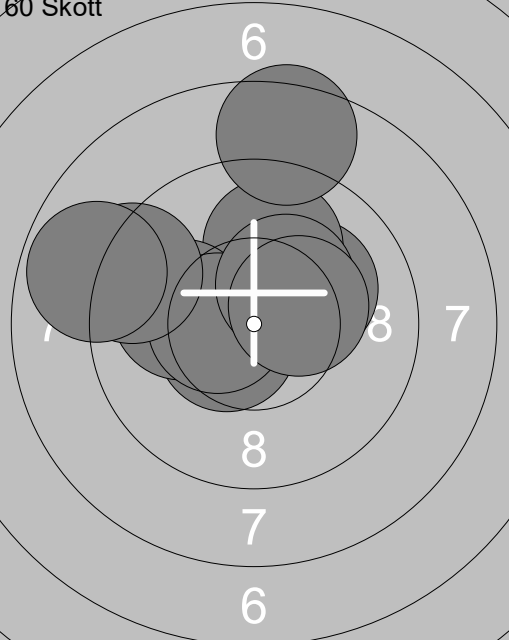
60 Skott 	31: 10.1 ↗ 32: 9.9 ↗ 33: 10.5 ✖↖ 34: 10.0 ↖ 35: 10.5 ✖↖ 36: 10.3 ✖↗ 37: 9.3 ↖ 38: 10.3 ✖➤ 39: 8.5 ↗ 40: 8.8 ↖ Serie 94.0 Total 378.0			
--	---	--	--	--

Prov 	1: 9.6 ↓ 2: 10.7x → 3: 8.5 ↓ 4: 9.6 → 5: 10.4x ↓ 6: 10.0 ← 7: 9.9 ↗ 8: 10.2x → 9: 9.7 ↙	Prov 	11: 10.2x → 12: 10.5x ↑ 13: 10.4x ↙ 14: 9.4 ↘ 15: 9.4 ← 16: 9.8 ↓ 17: 10.3x ↓ 18: 9.0 ↗ 19: 8.9 ↘ 20: 10.3x ↙
Serie	84.0	Serie	94.0
Total	0.0	Total	0.0

Prov 	21: 10.1 → 22: 10.2x ←	60 Skott 	1: 10.5x ↓ 2: 9.4 ↑ 3: 10.2x ↗ 4: 9.3 ↘ 5: 10.5x ↑ 6: 10.8x ↓ 7: 9.6 ↘ 8: 9.3 ↗ 9: 9.3 ↘ 10: 9.3 ↑
Serie	20.0	Serie	94.0
Total	0.0	Total	94.0

60 Skott 	11: 10.1 ↑ 12: 9.0 ↑ 13: 10.2x ↘ 14: 10.5x ← 15: 9.3 ↓ 16: 9.5 ↗ 17: 9.0 ↗ 18: 10.2x ↑ 19: 10.3x ↘ 20: 10.4x ↘	60 Skott 	21: 10.7x ↗ 22: 9.6 ← 23: 10.1 ↘ 24: 10.0 ↓ 25: 6.7 ↑ 26: 9.9 ↗ 27: 10.5x ↘ 28: 10.2x → 29: 10.1 ← 30: 9.8 ↑
Serie	96.0	Serie	93.0
Total	190.0	Total	283.0

60 Skott 	31: 9.6 ← 32: 10.0 ↑ 33: 9.2 ↑ 34: 10.4x ↗ 35: 8.0 ↘ 36: 9.4 ↘ 37: 9.9 ↗ 38: 9.6 ↗ 39: 9.7 ↘ 40: 8.8 ↘		
Serie	90.0		
Total	373.0		