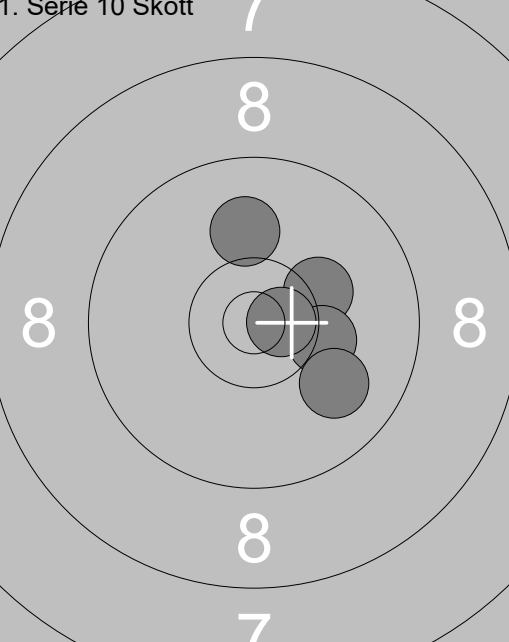
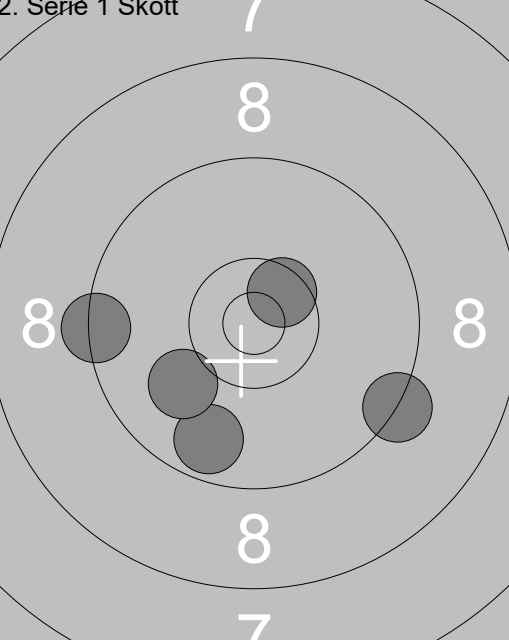
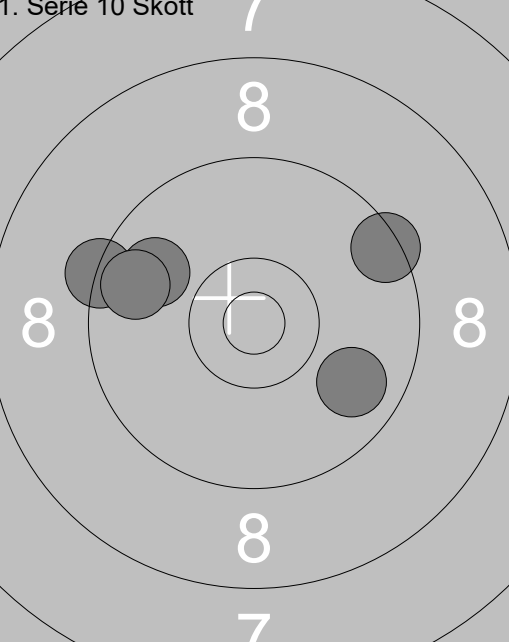
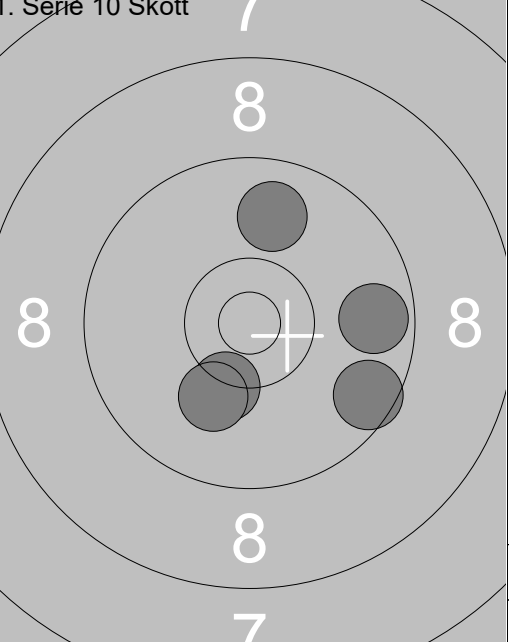
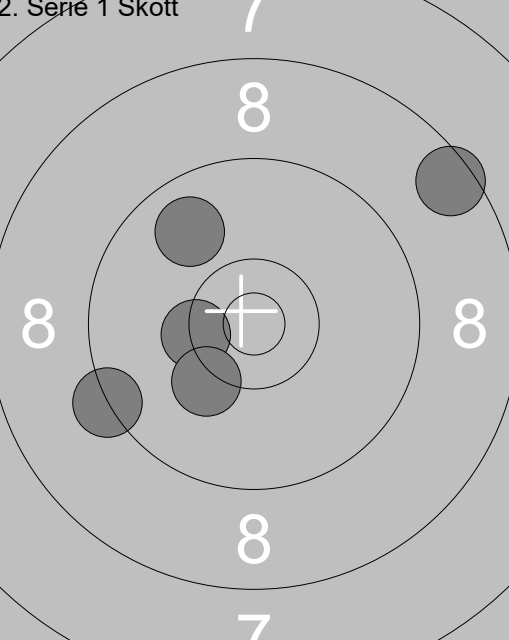
	<p>1: 10.8x ↘</p> <p>2: 9.4 ↙</p> <p>3: 9.1 ←</p> <p>4: 10.1 ↑</p> <p>5: 10.6x ↘</p> <p>6: 9.7 ↘</p> <p>7: 9.6 ↘</p> <p>8: 10.8x →</p> <p>9: 10.8x ↘</p> <p>10: 9.7 →</p>	<p>11: 10.6x ↗</p> <p>12: 9.9 ↖</p> <p>13: 10.5x ↘</p>
Serie 95.0		Serie 29.0
Total 191.0		Total 191.0

<p>1. Serie 10 Skott</p> 	<p>1: 10.2 ↗</p> <p>2: 10.0 ↑</p> <p>3: 10.2 →</p> <p>4: 10.7x →</p> <p>5: 9.9 ↘</p>	<p>6: 10.0 ↙</p> <p>7: 8.0 →</p> <p>8: 10.1 ↘</p> <p>9: 9.5 ↙</p> <p>10: 10.7x ↘</p>
Serie 49.0		Serie 47.0
Total 240.0		Total 287.0

<p>2. Serie 1 Skott</p> 	<p>1: 9.7 ↘</p> <p>2: 10.0 ↙</p> <p>3: 10.5x ↗</p> <p>4: 9.4 ←</p> <p>5: 9.3 →</p>	
Serie 47.0		
Total 334.0		

	<p>1: 10.3x ↘</p> <p>2: 9.8 ↗</p> <p>3: 9.3 ↗</p> <p>4: 10.3 ↘</p> <p>5: 9.6 ↘</p> <p>6: 9.4 ↘</p> <p>7: 10.4x ↘</p> <p>8: 10.3x ↗</p> <p>9: 10.1 ↗</p> <p>10: 9.8 ↘</p>		<p>11: 10.7x ↘</p>
Serie 95.0		Serie 10.0	
Total 191.0		Total 191.0	

<p>1. Serie 10 Skott</p> 	<p>1: 9.8 ↖</p> <p>2: 9.3 ↖</p> <p>3: 9.7 ↖</p> <p>4: 9.4 ↗</p> <p>5: 9.8 ↘</p>	<p>1. Serie 10 Skott</p> 	<p>6: 9.9 ↗</p> <p>7: 9.6 ↘</p> <p>8: 10.3 ↘</p> <p>9: 9.7 →</p> <p>10: 10.1 ↘</p>
Serie 45.0		Serie 47.0	
Total 236.0		Total 283.0	

<p>2. Serie 1 Skott</p> 	<p>1: 9.3 ↖</p> <p>2: 8.5 ↗</p> <p>3: 10.4x ↖</p> <p>4: 9.8 ↗</p> <p>5: 10.2 ↘</p>		
Serie 46.0			
Total 329.0			

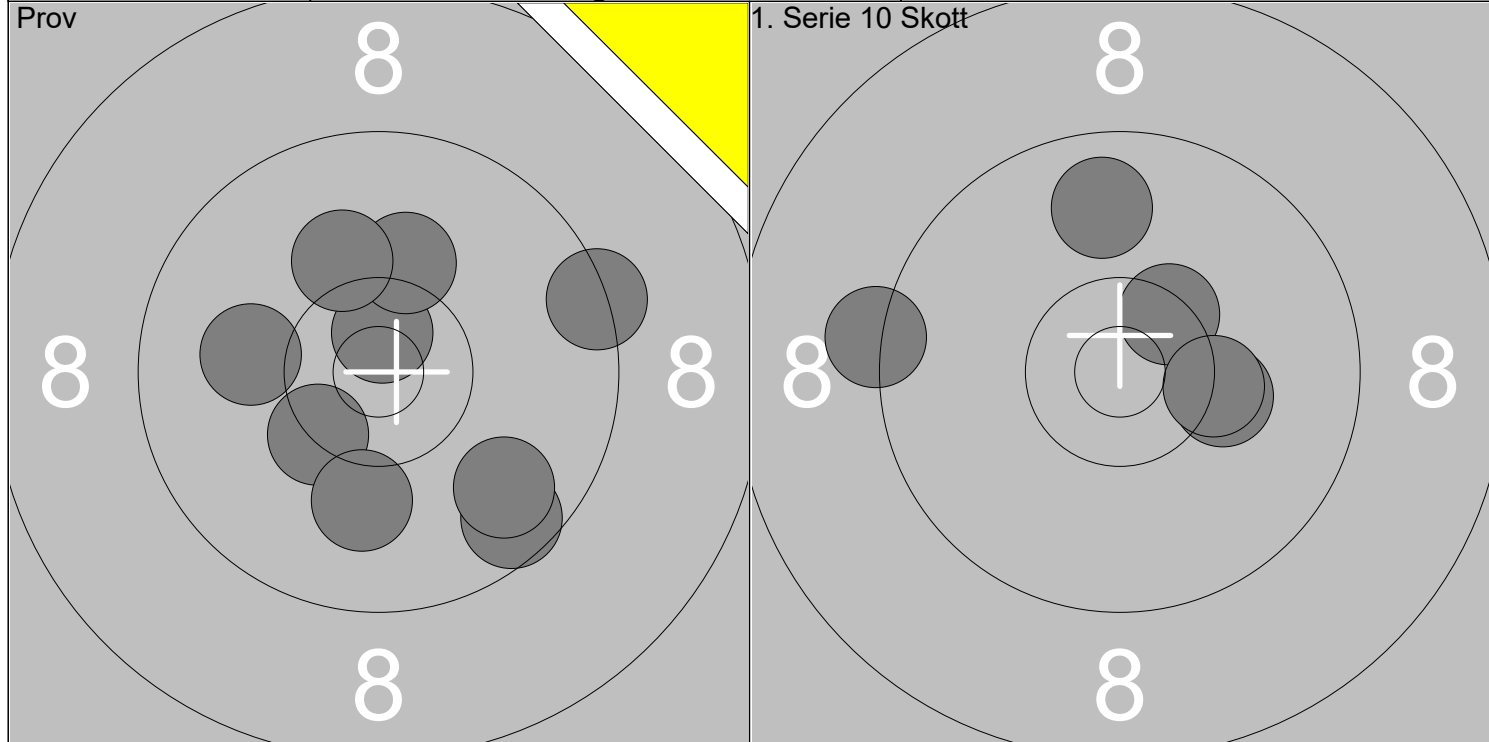

1: 10.4x ↙	6: 10.1 ←	Serie	87	1: 9.3 ←	Serie	48
2: 9.4 →	7: 9.8 ↘			2: 10.2 →		
3: 10.7x ↑	8: 10.1 ↓	Total	188	3: 9.8 ↑	Total	236
4: 9.6 ↘	9: 10.1 ↗			4: 10.4x ↗		
5: 10.2 ↑				5: 10.3x →		

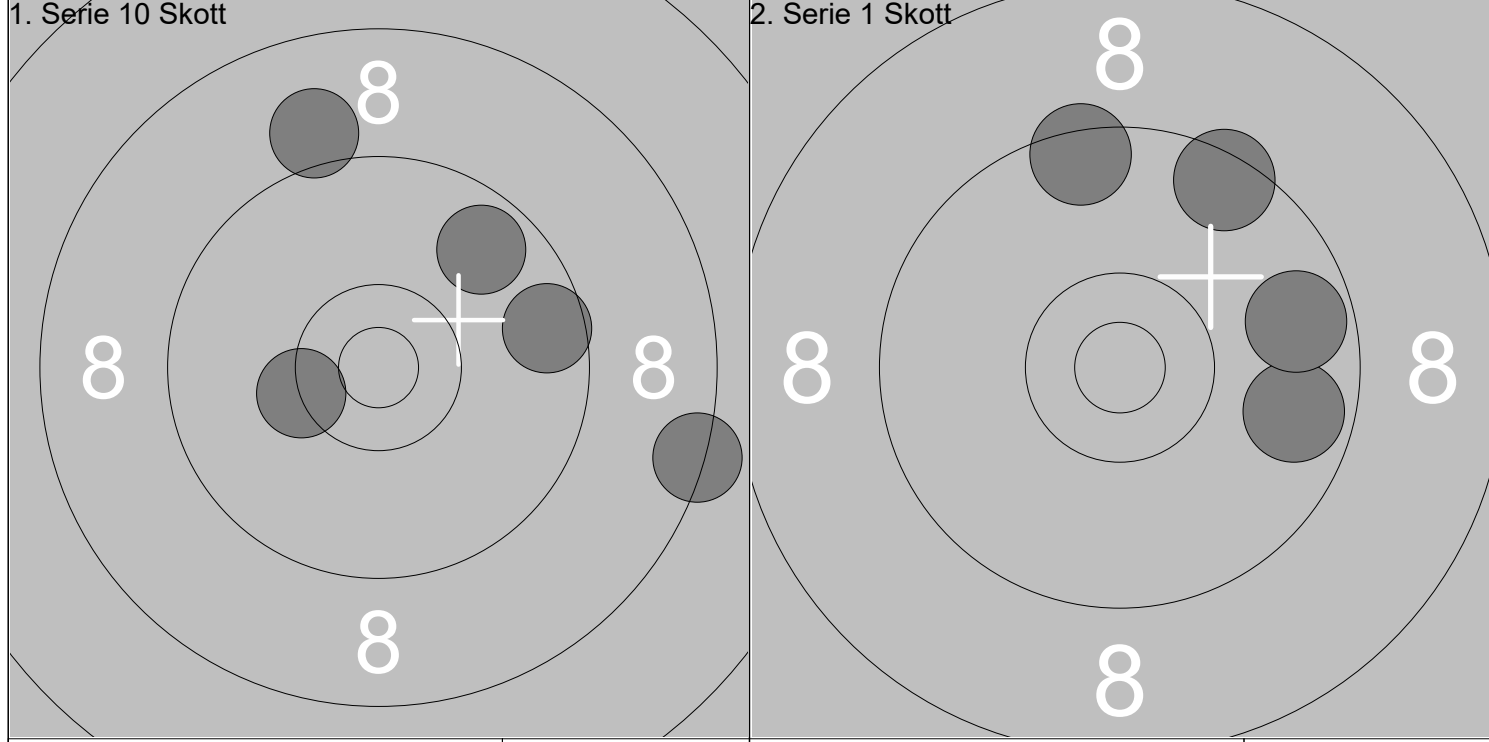

6: 9.7 ↗	Serie	45	1: 9.7 →	Serie	36
7: 8.4 →			2: 0.0		
8: 9.1 ↑	Total	281	3: 9.5 ↑	Total	317
9: 10.3x ←			4: 9.5 ↗		
10: 9.6 →			5: 9.7 →		

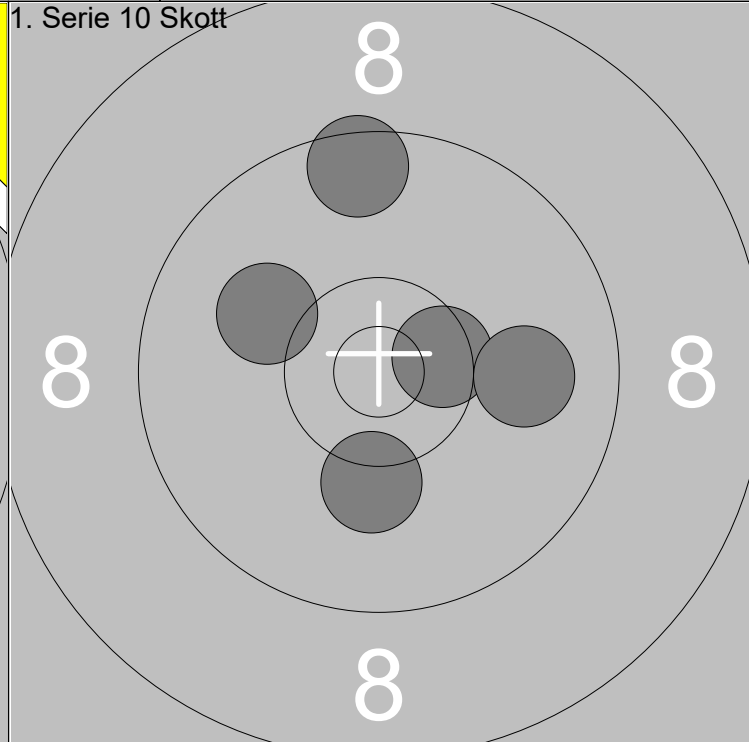
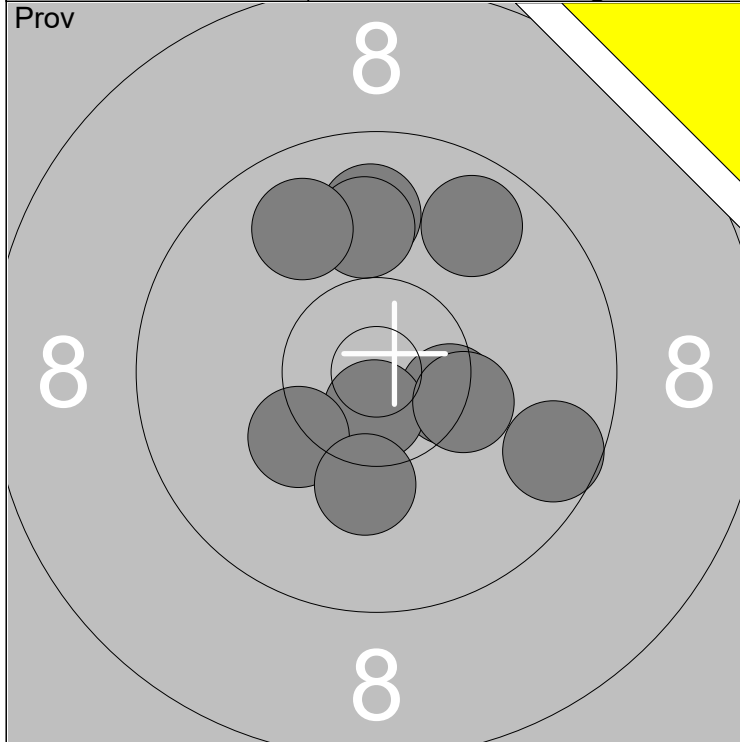

1: 9.9 ↑	6: 10.7x ↓	Serie	96
2: 9.8 ↗	7: 10.3x →		
3: 9.6 →	8: 10.3 ↙	Total	187
4: 10.4x →	9: 9.8 ↗		
5: 10.0 ↑	10: 10.2 ↓		

1: 10.5x →	Serie	49
2: 10.1 ↖		
3: 9.5 ↑	Total	236
4: 10.0 →		
5: 10.2 ↓		

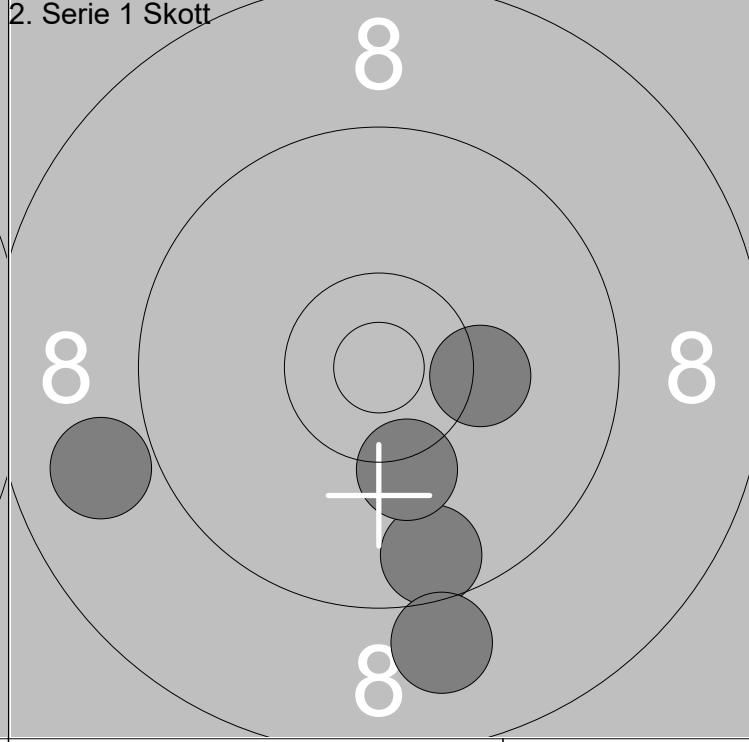
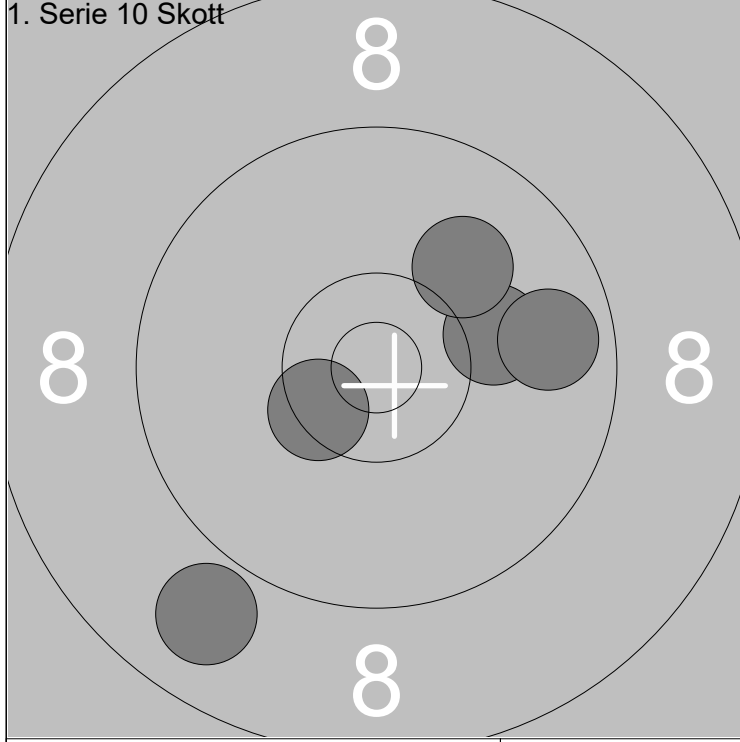

6: 10.1 →	Serie	47
7: 10.0 ↗		
8: 9.8 →	Total	283
9: 8.9 ↙		
10: 10.5x ↙		

1: 9.6 ↓	Serie	46
2: 9.0 ↓		
3: 10.2 ↓	Total	329
4: 8.9 ←		
5: 10.3 →		

Skjutlag

5

Tavla

5

Ingemar Månsson

Ramselefors

Helsingborg

5, SM Vet | Sk

16.07.2023

SM Korthåll Ställningar 2023

Ramselefors SKF

Prov

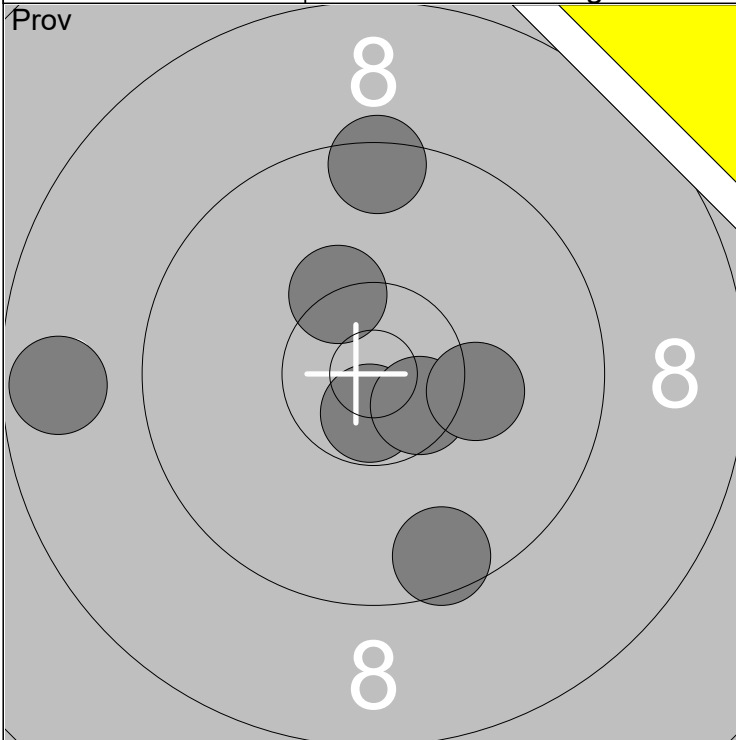

1. Serie 10 Skott

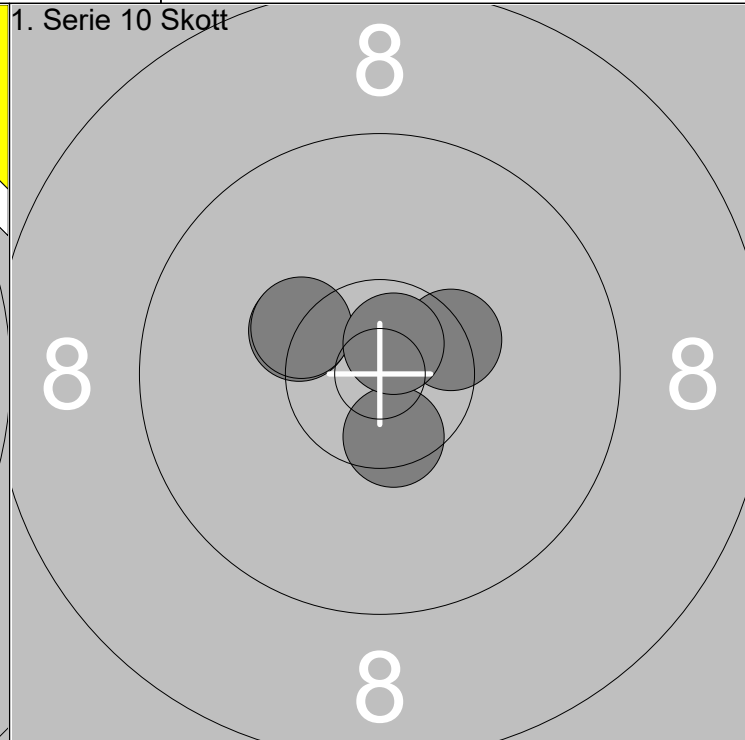

1: 9.5 ↑
 2: 8.7 ←
 3: 9.6 ↓
 4: 10.7x ↓
 5: 10.6x ↘

6: 10.3x ↖
 7: 10.2 →

Serie 66
 Total 186

1: 10.5x ↓
 2: 10.3x ↖
 3: 10.4x ↗
 4: 10.3x ↖
 5: 10.7x ↗

Serie 50
 Total 236

1. Serie 10 Skott

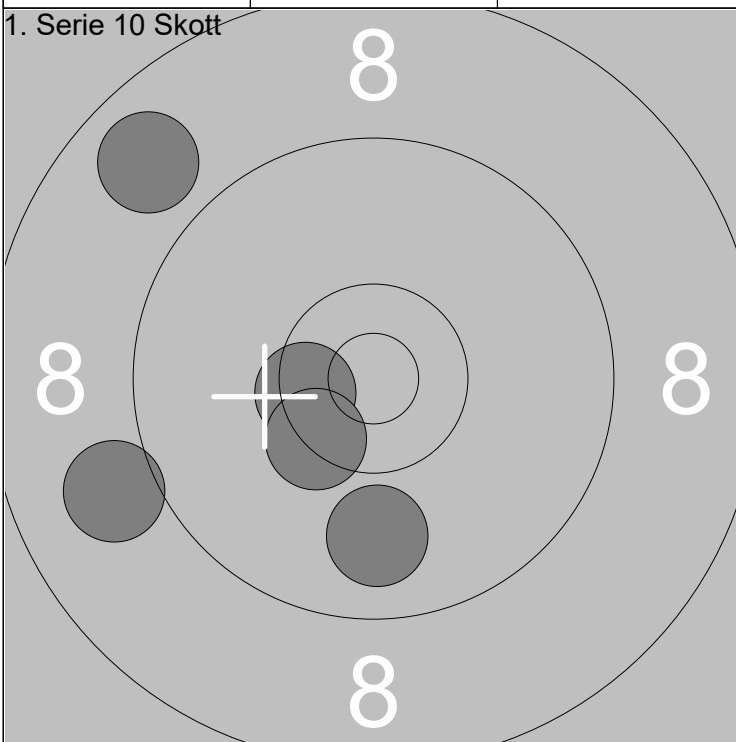

2. Serie 1 Skott

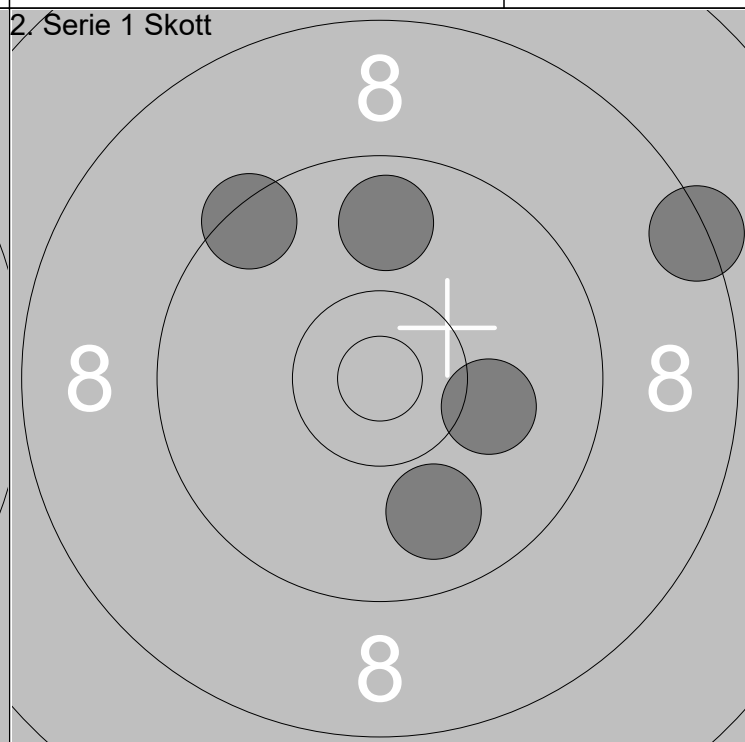

6: 9.9 ↓
 7: 10.5x ←
 8: 10.4x ↙
 9: 9.0 ←
 10: 8.8 ↖

Serie 46
 Total 282

1: 9.4 ↖
 2: 8.4 ↗
 3: 9.8 ↑
 4: 9.9 ↓
 5: 10.1 →

Serie 45
 Total 327

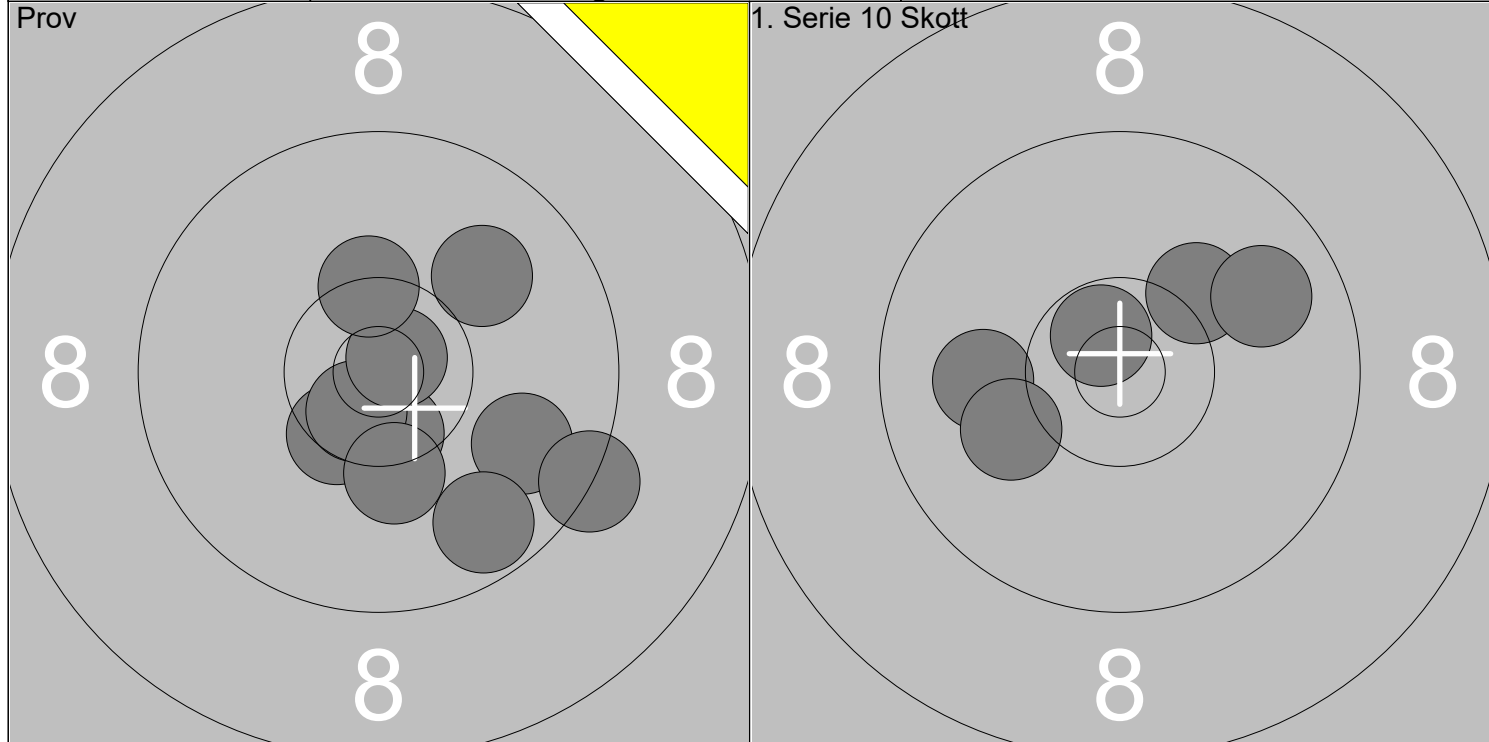

1: 10.4x ↙	6: 9.3 →	Serie	97	1: 10.2 ↗	Serie	49
2: 9.8 →	7: 10.6x ↙			2: 10.7x ↖		
3: 9.7 ↘	8: 10.2 ↓	Total	186	3: 10.0 ←	Total	235
4: 10.5x ↓	9: 10.8x ↗			4: 9.8 ↗		
5: 10.0 ↗	10: 10.4x ↑					5: 10.1 ↙

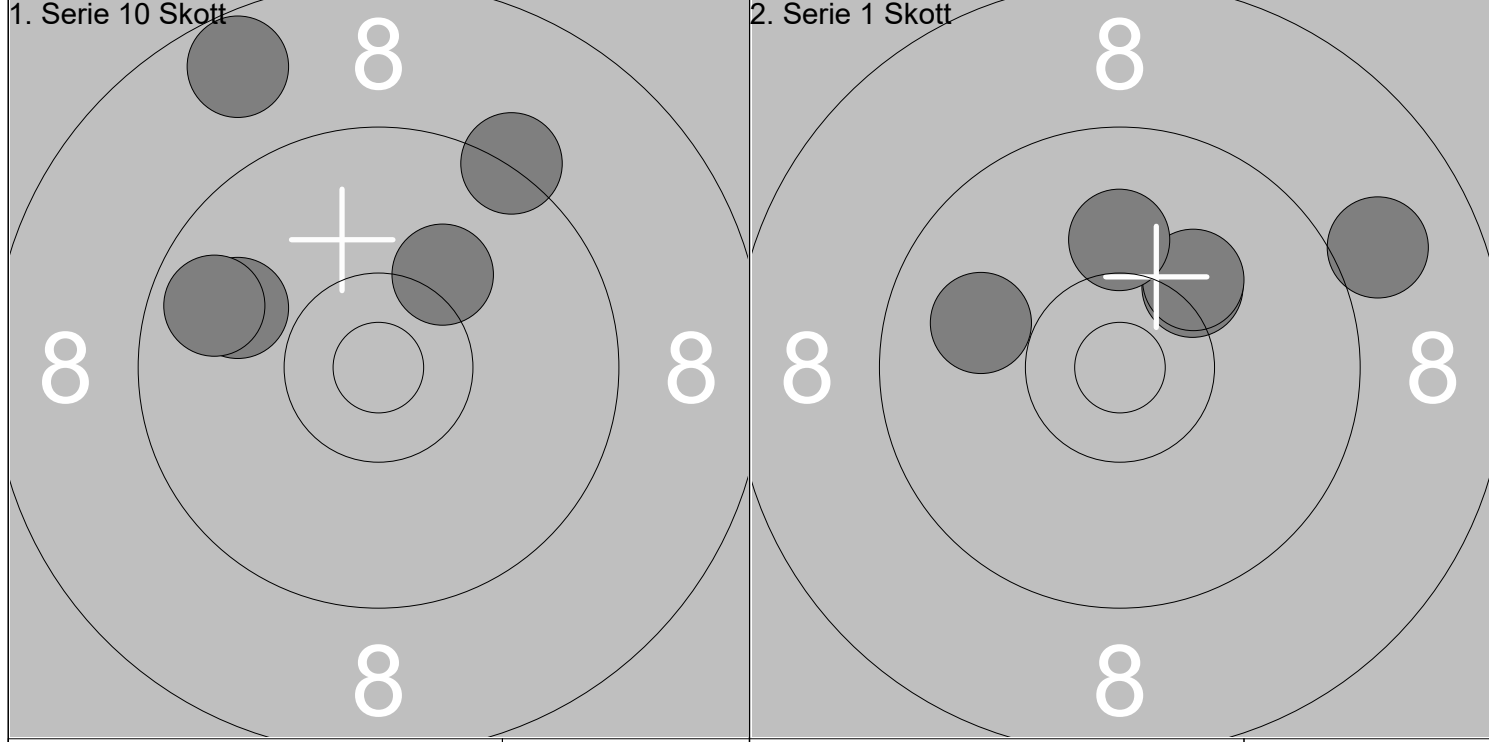

6: 10.2 ↗	Serie	45	1: 9.9 ←	Serie	48
7: 9.3 ↗			2: 10.2 ↗		
8: 9.9 ↖	Total	280	3: 9.0 ↗	Total	328
9: 9.7 ↖			4: 10.2 ↗		
10: 8.7 ↗					5: 10.1 ↑

	<p>1: 10.7x ↘</p> <p>2: 10.1 ←</p> <p>3: 9.7 →</p> <p>4: 9.2 →</p> <p>5: 9.4 ↘</p> <p>6: 10.4x ↘</p> <p>8: 10.6x ↘</p> <p>9: 10.0 ←</p> <p>10: 10.2 ←</p>	<p>11: 8.6 ↙</p> <p>12: 9.5 →</p>
Serie 87.0		Serie 17.0
Total 186.0		Total 186.0

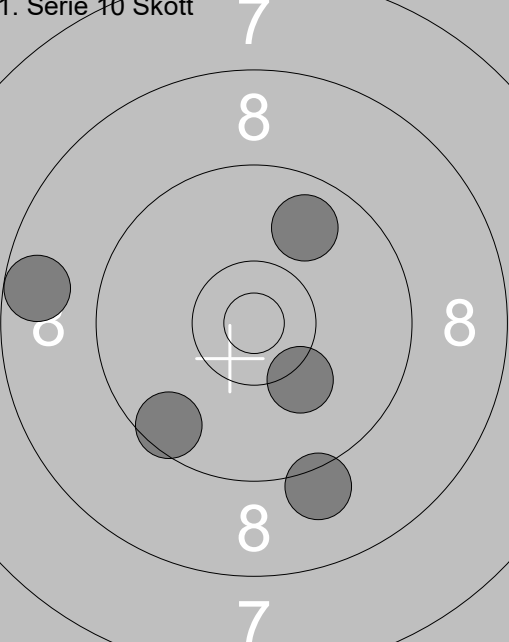
<p>1. Serie 10 Skott</p> 	<p>1: 9.6 ↙</p> <p>2: 9.8 ↗</p> <p>3: 9.1 ↘</p> <p>4: 10.2 ↘</p> <p>5: 8.7 ←</p>	<p>6: 8.9 ↙</p> <p>7: 7.9 →</p> <p>8: 10.1 →</p> <p>9: 9.4 ↘</p> <p>10: 9.6 ↗</p>
Serie 45.0		Serie 43.0
Total 231.0		Total 274.0

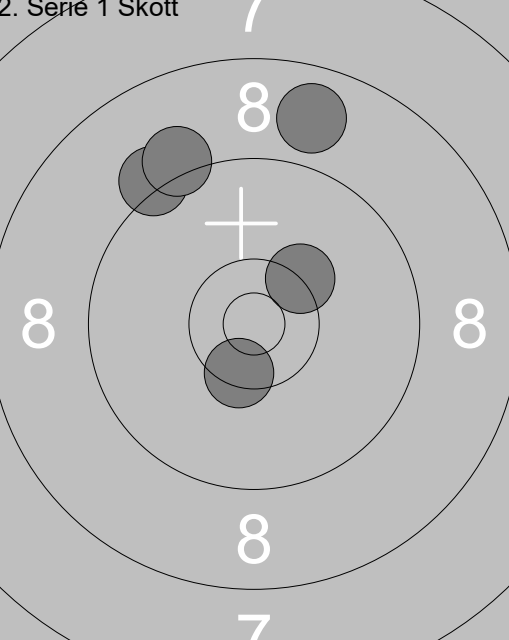
<p>2. Serie 1 Skott</p> 	<p>1: 10.4x ↘</p> <p>2: 9.2 ↖</p> <p>3: 10.3x ↗</p> <p>4: 8.8 ↗</p> <p>5: 9.2 ↖</p>	
Serie 46.0		
Total 320.0		

	<p>1: 10.5x ↘</p> <p>2: 10.5x ↗</p> <p>3: 10.4x ↘</p> <p>4: 10.6x ↗</p> <p>5: 10.7x ↘</p> <p>6: 10.5x ↘</p> <p>7: 9.1 ↙</p> <p>8: 10.6x ↘</p> <p>9: 10.1 ↗</p> <p>10: 9.7 →</p>	
Serie 98.0		Serie 17.0
Total 185.0		Total 185.0

<p>1. Serie 10 Skott</p>	<p>1: 9.9 ↘</p> <p>2: 10.8x ↗</p> <p>3: 9.2 →</p> <p>4: 9.2 ↙</p> <p>5: 10.7x ↘</p>	<p>1. Serie 10 Skott</p>
Serie 47.0		Serie 37.0
Total 232.0		Total 269.0

<p>2. Serie 1 Skott</p>	<p>1: 8.9 ↘</p> <p>2: 10.5x ↘</p> <p>3: 9.3 →</p> <p>4: 9.6 ↗</p> <p>5: 8.4 ↘</p>	
Serie 44.0		
Total 313.0		

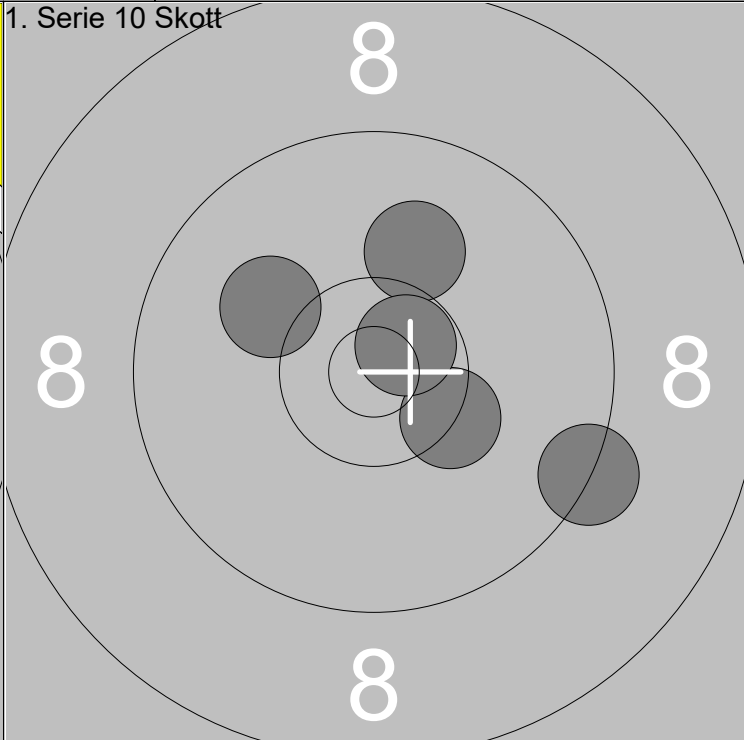
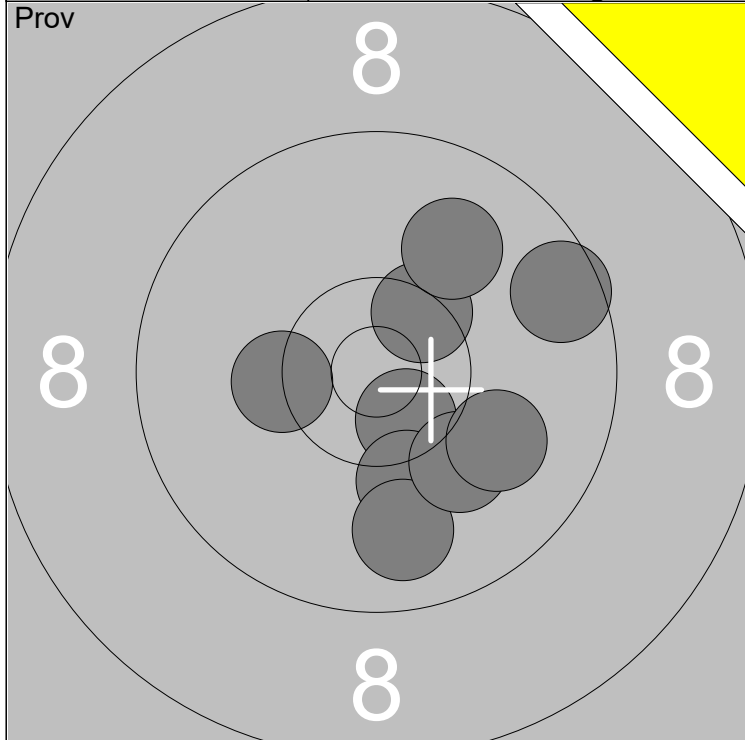

1: 10.6x ↘	6: 9.8 ↘	Serie	88
2: 10.2 ↘	7: 10.1 ↘		
3: 9.6 ↗	8: 10.0 ↘	Total	185
4: 10.4x ↗	9: 10.3x ←		
5: 10.0 ↗			

1: 10.1 ↗	Serie	49
2: 10.3x ↘		
3: 10.1 ↖	Total	234
4: 9.3 ↘		
5: 10.7x ↗		

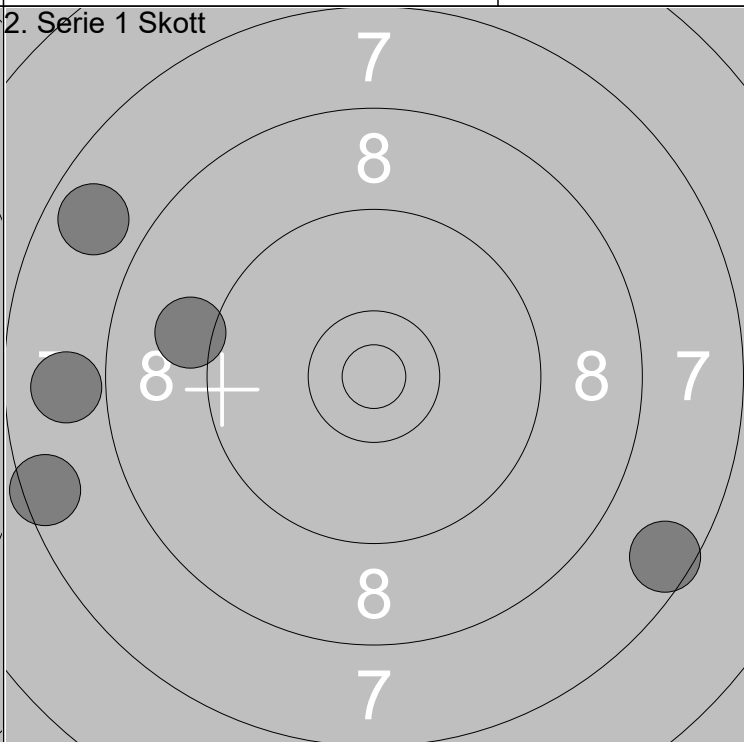
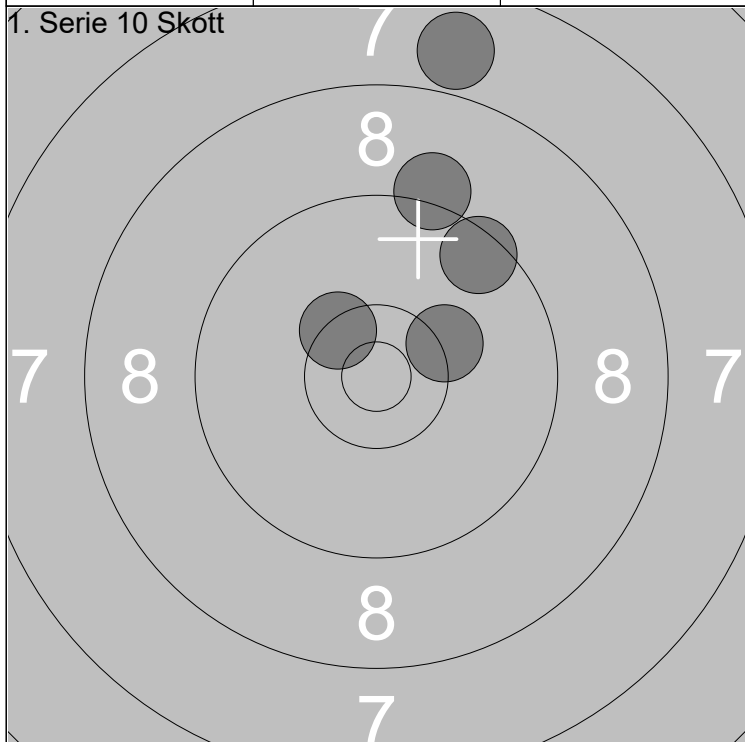

6: 10.4x ↖	Serie	45
7: 7.9 ↗		
8: 9.5 ↗	Total	279
9: 10.3 ↗		
10: 9.2 ↗		

1: 7.5 ←	Serie	37
2: 7.8 ↖		
3: 7.6 ↘	Total	316
4: 7.9 ←		
5: 9.1 ←		

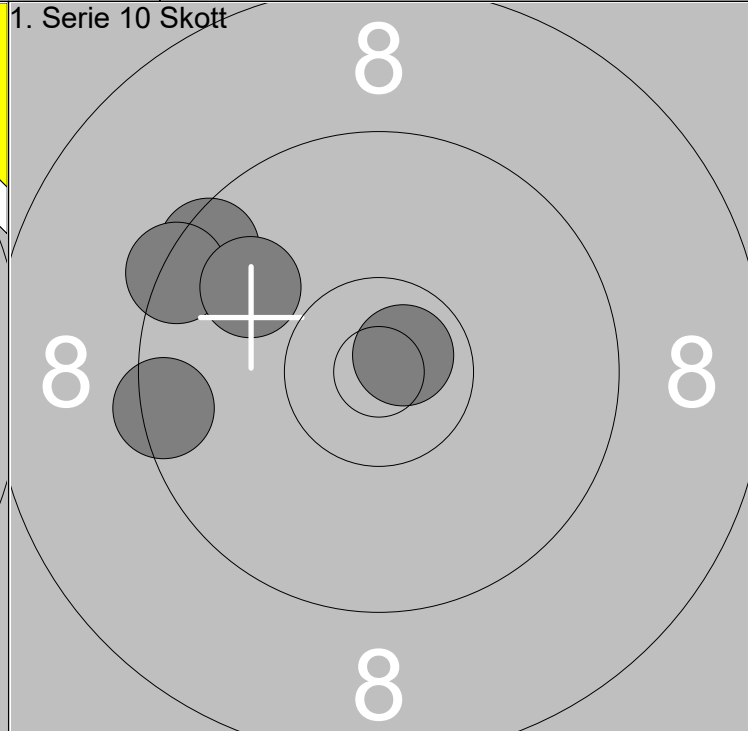
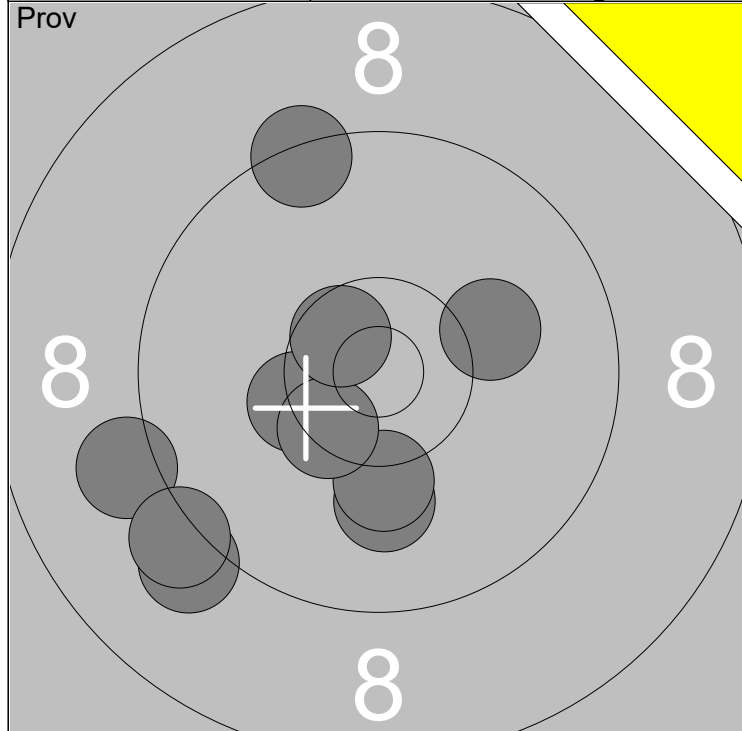

1: 9.1 ↙	6: 9.2 ↙	Serie	96
2: 9.1 ←	7: 10.2 ↓		
3: 10.1 →	8: 10.4x ↙	Total	184
4: 10.1 ↓	9: 10.6x ↖		
5: 10.4x ←	10: 9.4 ↗		

1: 9.5 ↗	Serie	46
2: 9.4 ←		
3: 9.4 ↖	Total	230
4: 9.9 ↖		
5: 10.7x ↗		

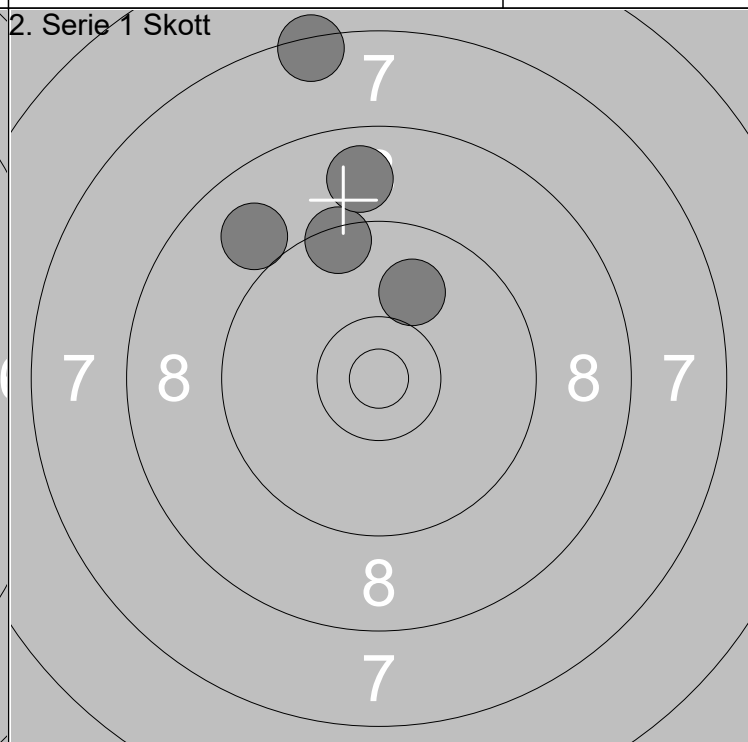
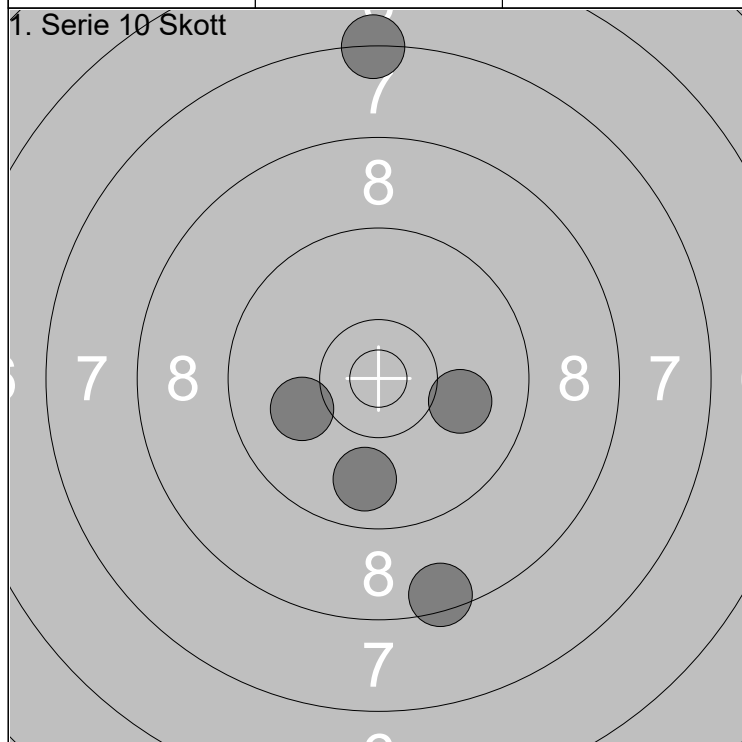

6: 9.8 ↓	Serie	44
7: 7.3 ↑		
8: 8.5 ↓	Total	274
9: 10.0 ←		
10: 10.0 →		

1: 10.0 ↗	Serie	43
2: 9.4 ↗		
3: 9.0 ↖	Total	317
4: 8.8 ↑		
5: 7.4 ↑		

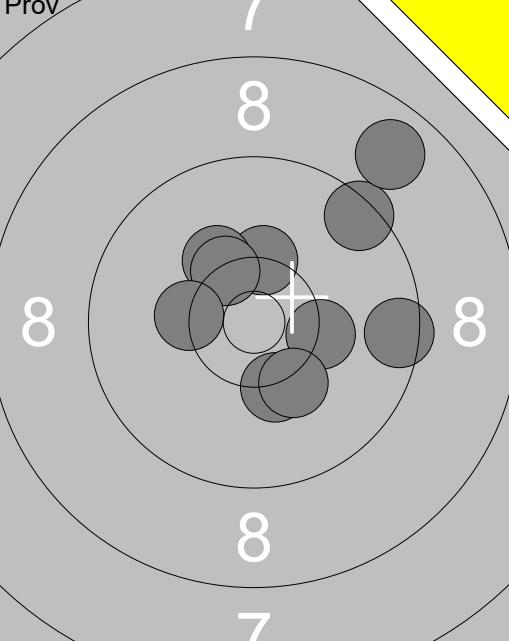
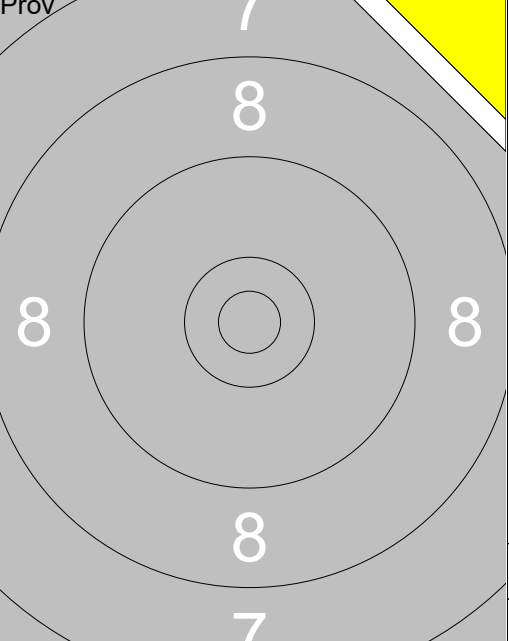
	<p>Prov</p> <p>1: 10.3x↑</p> <p>2: 10.3↓</p> <p>3: 9.5 →</p> <p>4: 10.2↖</p> <p>5: 10.3→</p> <p>6: 10.2↓</p> <p>7: 9.5 ↗</p> <p>8: 8.8 ↗</p> <p>9: 10.4x↖</p> <p>10: 10.3x←</p>	
Serie 96.0		Serie 0.0
Total 183.0		Total 183.0

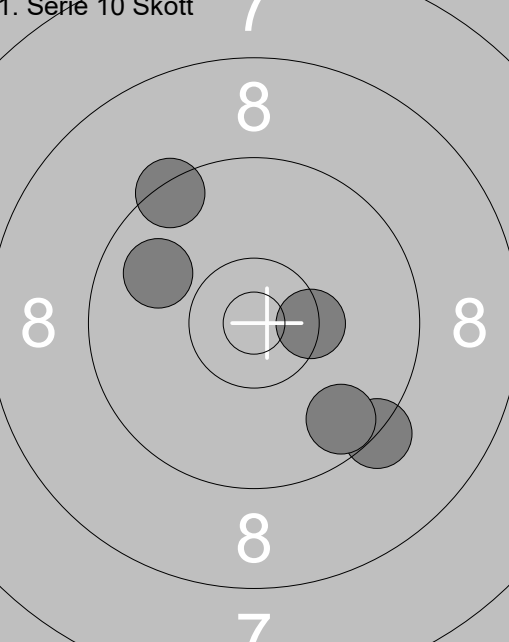
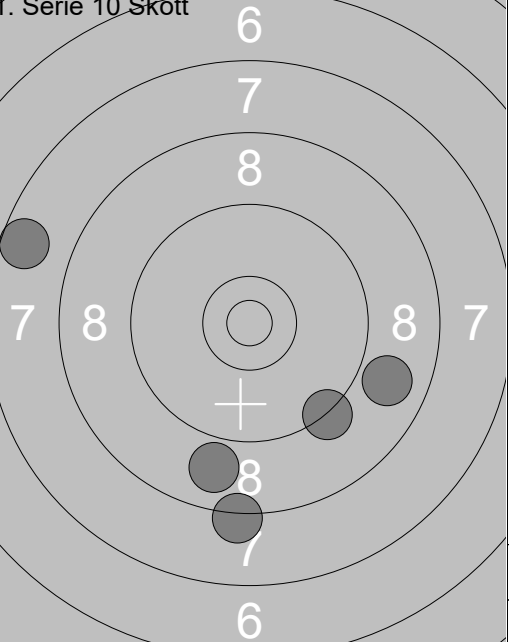
<p>1. Serie 10 Skott</p> 	<p>1: 9.4 ↗</p> <p>2: 9.3 ↓</p> <p>3: 9.9 ↖</p> <p>4: 9.7 ↓</p> <p>5: 10.4x→</p>	<p>1. Serie 10 Skott</p> 
Serie 46.0		Serie 40.0
Total 229.0		Total 269.0

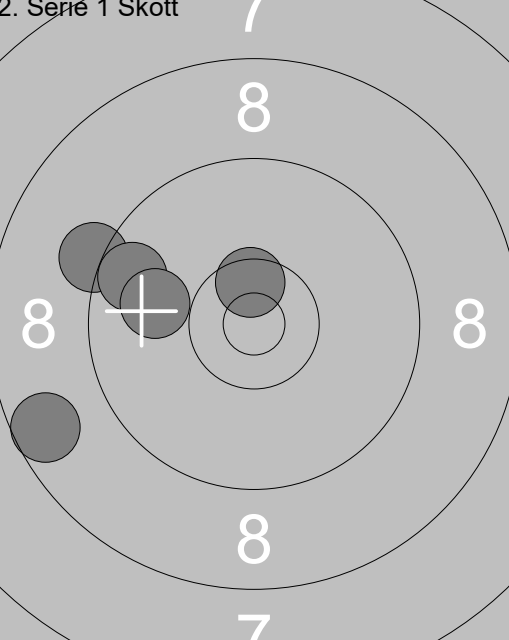
<p>2. Serie 1 Skott</p> 	<p>1: 10.5x↑</p> <p>2: 8.6 ↖</p> <p>3: 9.2 ↖</p> <p>4: 9.6 ↖</p> <p>5: 9.9 ↖</p>	
Serie 45.0		
Total 314.0		

	<p>1: 9.9 ←</p> <p>2: 8.5 ↖</p> <p>3: 7.8 ↘</p> <p>4: 10.3x↓</p> <p>5: 9.5 ↑</p> <p>6: 10.4x→</p> <p>7: 10.0 →</p> <p>8: 10.5x↓</p> <p>9: 10.1 →</p> <p>10: 10.4x↓</p>		<p>11: 9.8 ↖</p> <p>12: 9.9 ↗</p>
Serie 93.0		Serie 18.0	
Total 182.0		Total 182.0	

<p>1. Serie 10 Skott</p>	<p>1: 10.1 ↖</p> <p>2: 8.8 ←</p> <p>3: 10.3x↖</p> <p>4: 8.1 ↖</p> <p>5: 9.8 ←</p>	<p>1. Serie 10 Skott</p>	<p>6: 9.9 →</p> <p>7: 9.0 ↘</p> <p>8: 8.2 →</p> <p>9: 9.7 ↘</p> <p>10: 8.8 ↖</p>
Serie 45.0		Serie 43.0	
Total 227.0		Total 270.0	

<p>2. Serie 1 Skott</p>	<p>1: 8.7 ↓</p> <p>2: 7.9 →</p> <p>3: 9.2 ↑</p> <p>4: 10.7x↖</p> <p>5: 8.2 ↖</p>		
Serie 42.0			
Total 312.0			

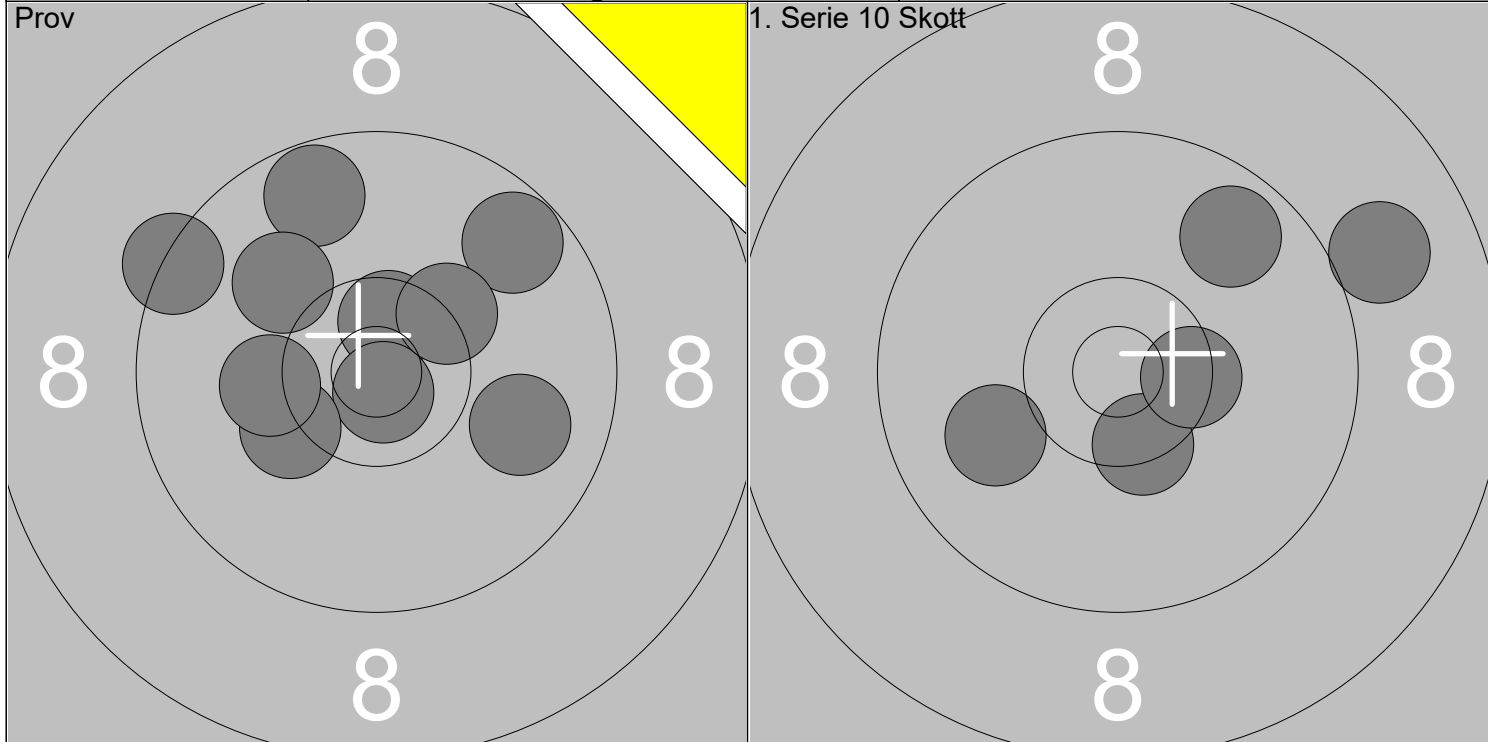

1: 9.7 ↗	6: 10.8x ↓	Serie	96	1: 10.0 ←	Serie	48	
2: 9.7 ↑	7: 10.2 ↙			2: 10.4x ↓			
3: 9.4 ↖	8: 10.3x ↗	Total	181	3: 9.0 ↗	Total	229	
4: 9.9 →	9: 10.1 ↖			4: 10.4x →			
5: 10.6x ↑	10: 10.2 ←					5: 9.7 ↗	

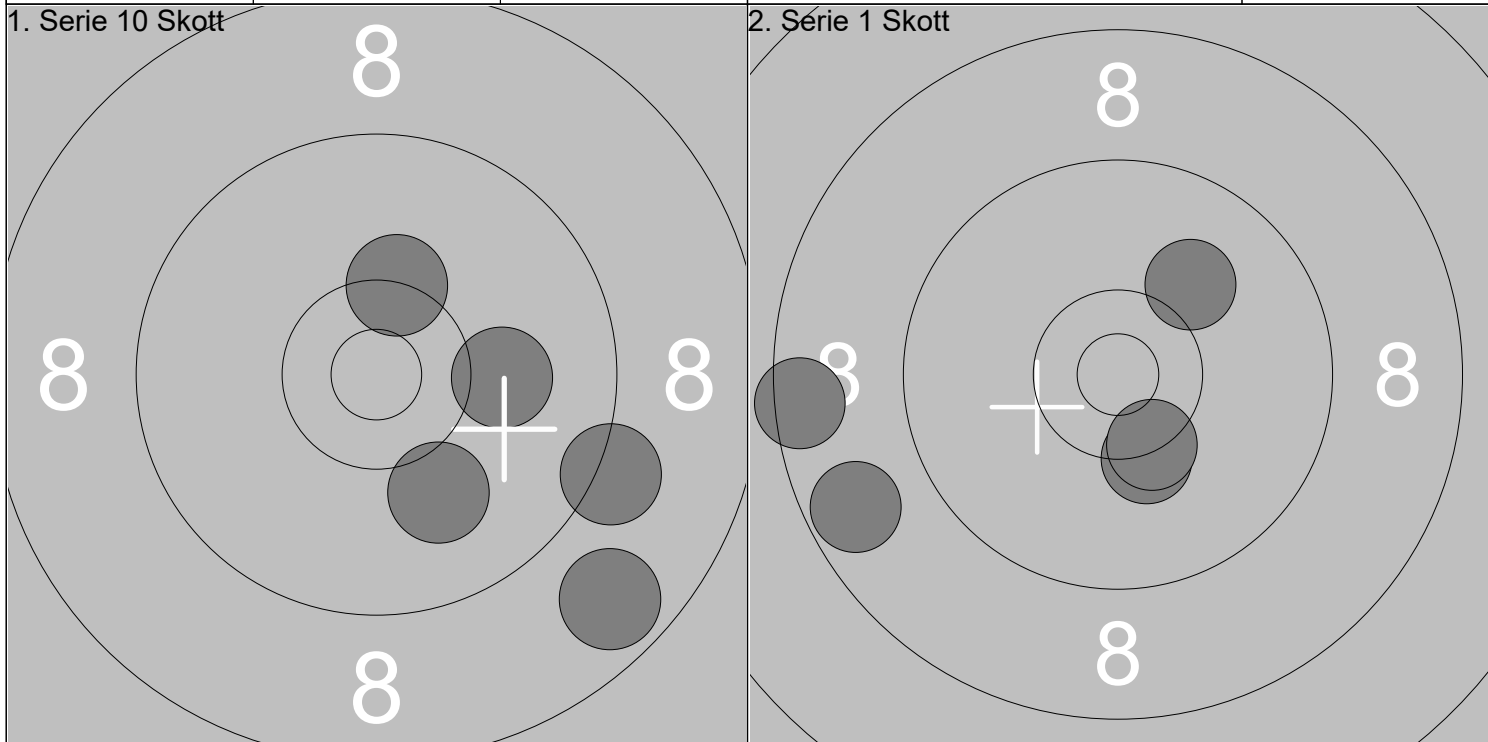

6: 10.1 →	Serie	47	1: 10.3 ↓	Serie	46	
7: 8.7 ↓			2: 8.7 ←			
8: 9.2 ↓	Total	276	3: 10.1 ↗	Total	322	
9: 10.3x ↑			4: 10.3x ↓			
10: 10.0 ↓					5: 8.5 ←	

	<p>1: 10.1 ↑</p> <p>2: 9.5 ↗</p> <p>3: 9.7 →</p> <p>4: 10.3x➤</p> <p>5: 9.4 →</p> <p>6: 10.5x↗</p> <p>7: 9.7 ↘</p> <p>8: 9.8 ↓</p> <p>9: 10.3←</p> <p>10: 10.0→</p>	<p>11: 10.2↙</p> <p>12: 9.9 ↘</p>
Serie 95.0		Serie 19.0
Total 181.0		Total 181.0

<p>1. Serie 10 Skott</p>	<p>1: 10.5x↘</p> <p>2: 9.4 ↓</p> <p>3: 10.1 ↓</p> <p>4: 9.0 ↓</p> <p>5: 9.7 ↘</p>	<p>1. Serie 10 Skott</p>
Serie 47.0		Serie 42.0
Total 228.0		Total 270.0

<p>2. Serie 1 Skott</p>	<p>1: 8.7 ↗</p> <p>2: 10.1 ↗</p> <p>3: 9.2 ↖</p> <p>4: 10.0 ↘</p> <p>5: 10.9x➤</p>	
Serie 47.0		
Total 317.0		

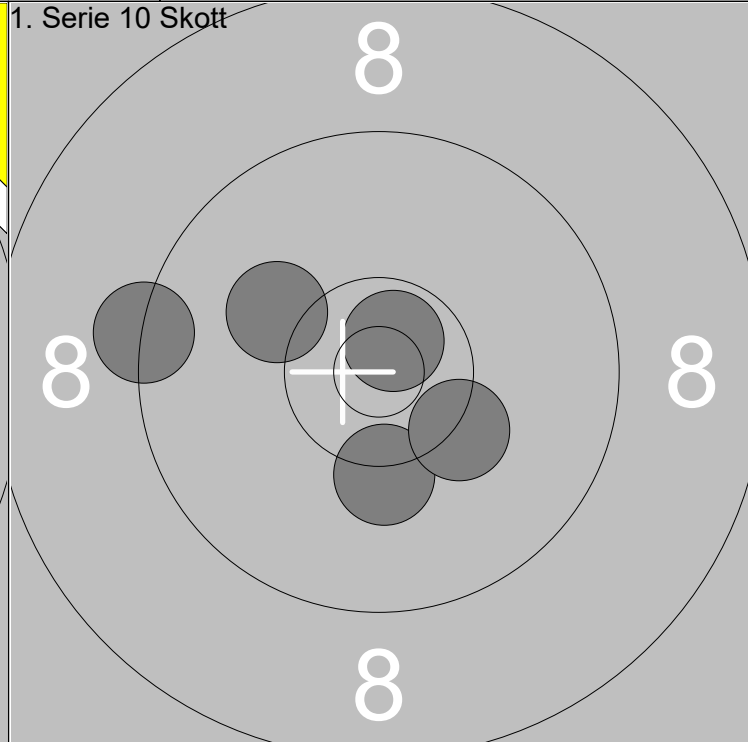
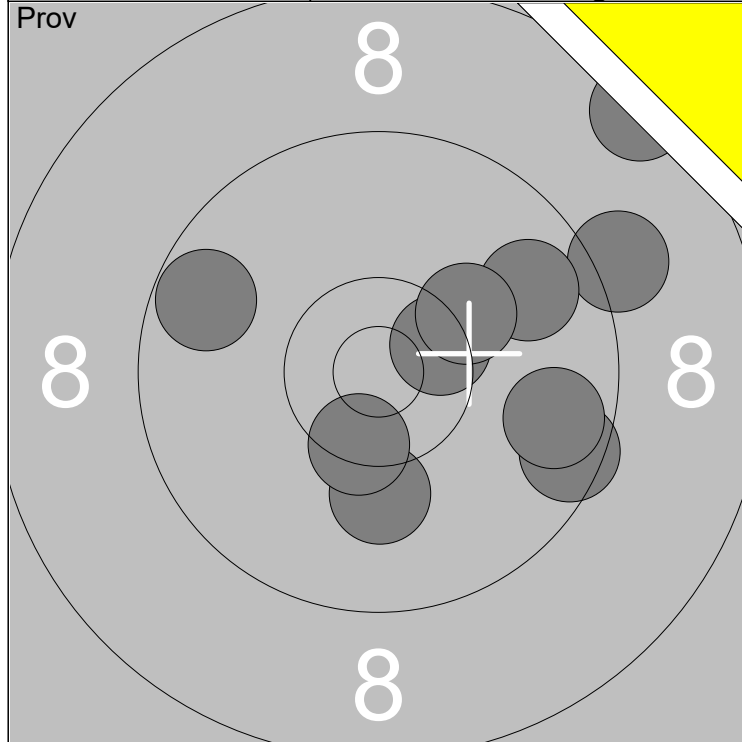

1: 8.4 ↗	6: 10.5x →	Serie	93
2: 9.1 →	7: 10.1 ↓		
3: 9.8 →	8: 9.7 ←	Total	181
4: 9.5 →	9: 10.2 →		
5: 9.7 →	10: 10.4x ↓		

1: 10.2 ↓	Serie	49
2: 9.3 ←		
3: 10.1 ↖	Total	230
4: 10.3 →		
5: 10.7x ↗		

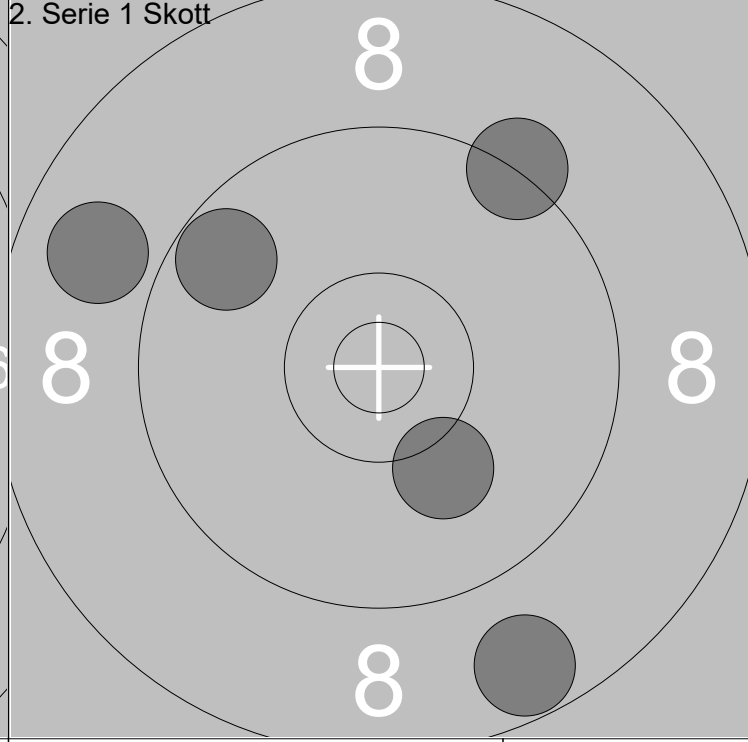
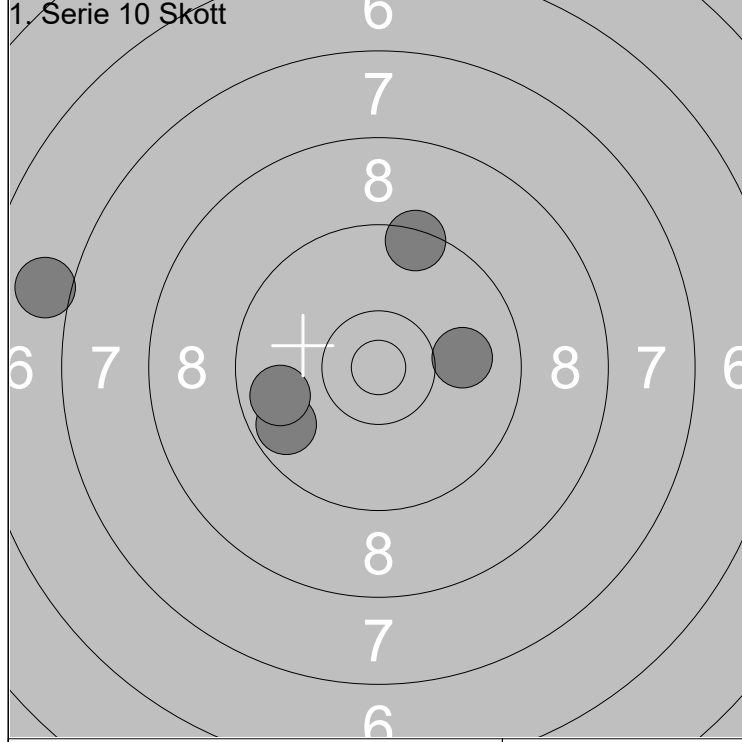

6: 10.0 →	Serie	44
7: 9.4 ↑		
8: 9.7 ←	Total	274
9: 7.0 ←		
10: 9.8 ←		

1: 8.7 ↓	Serie	44
2: 8.9 ↖		
3: 9.3 ↗	Total	318
4: 9.7 ↖		
5: 10.1 ↓		

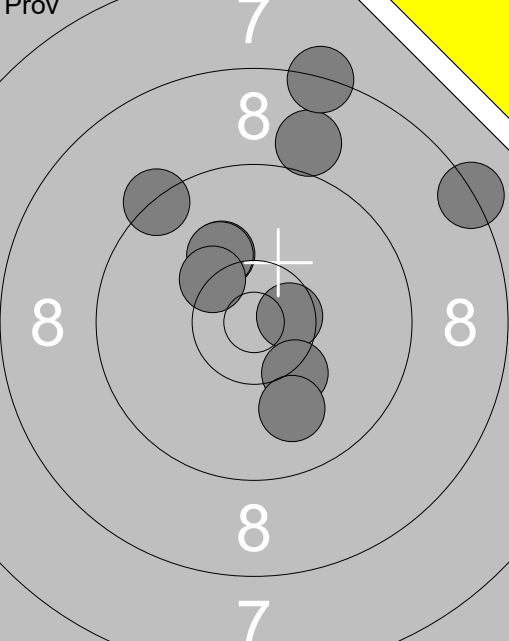
	<p>1: 9.0 ↑</p> <p>2: 10.6x →</p> <p>3: 10.2 ↖</p> <p>4: 8.3 ↑</p> <p>5: 8.3 →</p> <p>6: 10.2 ↖</p> <p>7: 10.3 ↘</p> <p>8: 10.3x ↘</p> <p>9: 9.3 ↖</p> <p>10: 10.0 ↘</p>	<p>11: 8.9 ←</p> <p>12: 9.3 ↗</p> <p>13: 10.6x →</p> <p>14: 9.5 ↑</p> <p>15: 10.0 ↗</p>
Serie 94.0		Serie 46.0
Total 181.0		Total 181.0

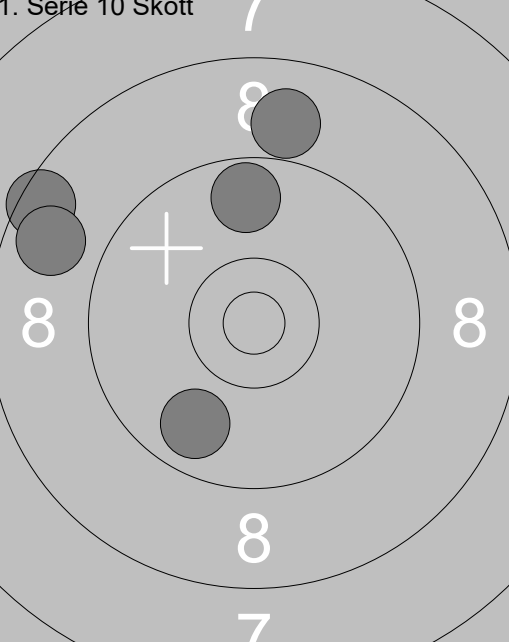
<p>1. Serie 10 Skott</p> 	<p>1: 8.5 ↖</p> <p>2: 8.8 ←</p> <p>3: 8.9 ↑</p> <p>4: 9.8 ↘</p> <p>5: 9.7 ↑</p>	<p>6: 10.6x ↘</p> <p>7: 8.5 ↑</p> <p>8: 10.4x ↘</p> <p>9: 9.0 →</p> <p>10: 9.4 ↖</p>
Serie 42.0		Serie 46.0
Total 223.0		Total 269.0

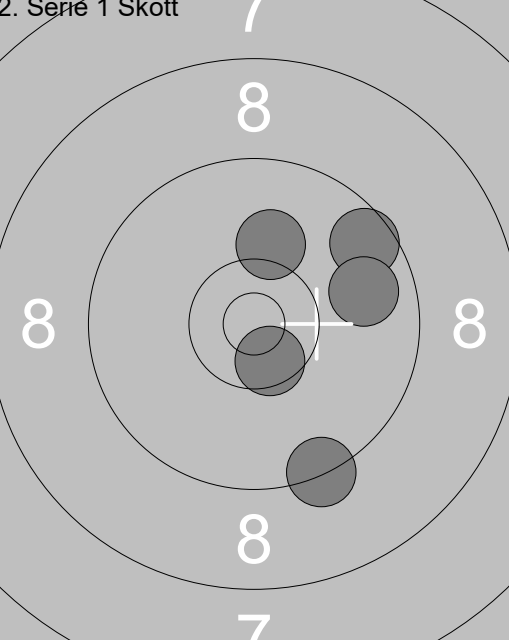
<p>2. Serie 1 Skott</p> 	<p>1: 9.3 ↘</p> <p>2: 9.6 ↗</p> <p>3: 10.1 ↑</p> <p>4: 9.8 →</p> <p>5: 10.5x ↘</p>	
Serie 47.0		
Total 316.0		

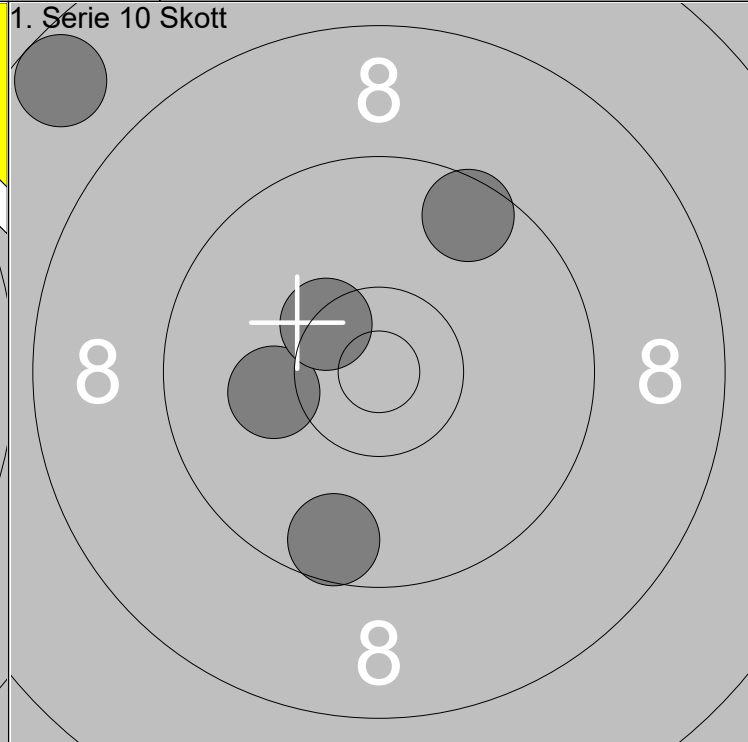
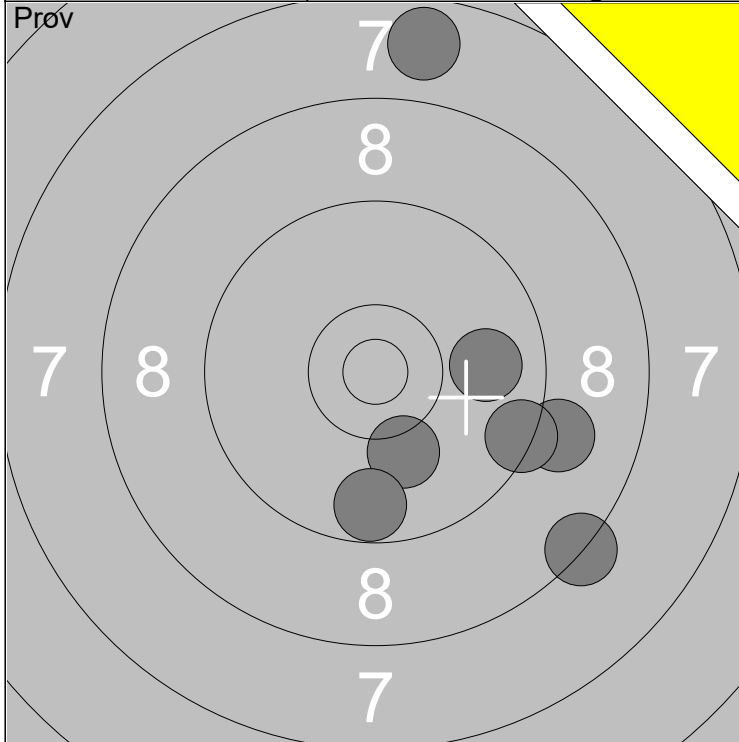

1: 7.7 ↑	6: 9.9 →	Serie 61
2: 10.1 ↓	7: 9.7 ↓	
3: 8.3 ↓		Total 180
4: 9.1 →		
5: 9.4 →		

1: 10.1 ←	Serie 45
2: 9.6 ↗	
3: 7.7 ↖	Total 225
4: 10.4x ↖	
5: 9.6 ↓	

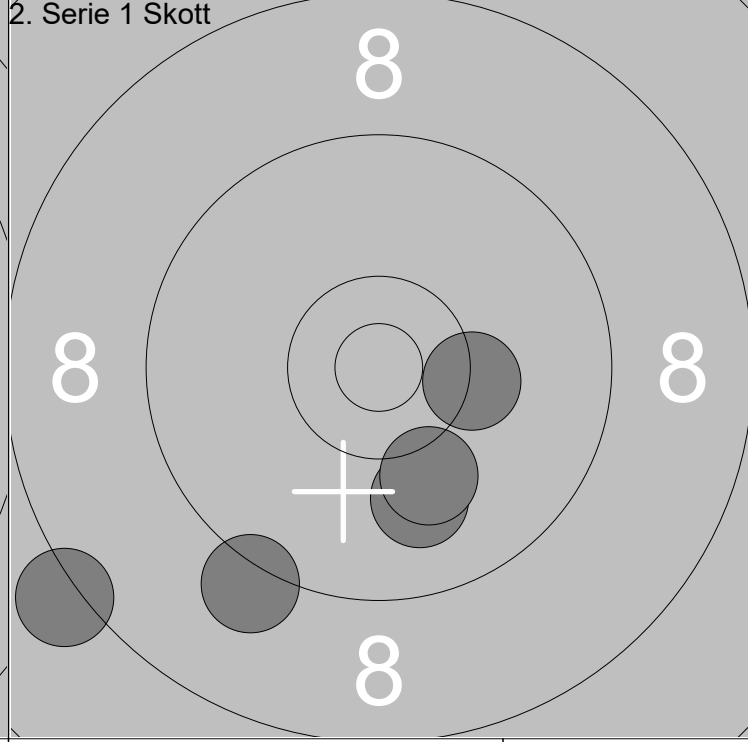
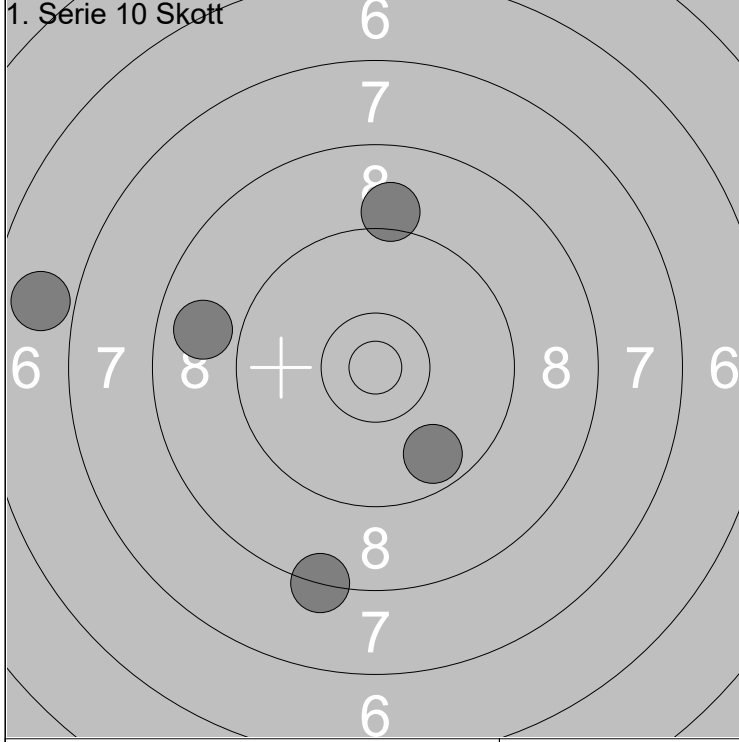

6: 8.9 ←	Serie 40
7: 9.7 ↓	
8: 9.1 ↑	Total 265
9: 8.3 ↓	
10: 6.9 ←	

1: 8.2 ←	Serie 47
2: 10.0 ↓	
3: 10.3 →	Total 312
4: 10.1 ↓	
5: 9.2 ↙	

	<p>1: 9.5 ↗</p> <p>2: 9.0 ↑</p> <p>3: 10.1 →</p> <p>4: 9.4 ↗</p> <p>5: 9.8 ←</p> <p>6: 9.5 ↗</p> <p>7: 10.1 ↘</p> <p>8: 9.8 ←</p> <p>9: 10.5x ↓</p> <p>10: 9.3 →</p> <hr/> <p>Serie 93.0</p> <hr/> <p>Total 180.0</p>		<p>11: 9.9 ←</p> <hr/> <p>Serie 9.0</p> <hr/> <p>Total 180.0</p>
--	---	--	--

<p>1. Serie 10 Skott</p>	<p>1: 9.5 ↓</p> <p>2: 9.6 ↓</p> <p>3: 8.8 ←</p> <p>4: 10.1 ↖</p> <p>5: 9.7 ↓</p> <hr/> <p>Serie 45.0</p> <hr/> <p>Total 225.0</p>	<p>1. Serie 10 Skott</p>	<p>6: 9.5 →</p> <p>7: 9.3 ↗</p> <p>8: 9.5 ↗</p> <p>9: 7.8 →</p> <p>10: 8.5 →</p> <hr/> <p>Serie 42.0</p> <hr/> <p>Total 267.0</p>
--------------------------	---	--------------------------	---

<p>2. Serie 1 Skott</p>	<p>1: 10.0 ↘</p> <p>2: 9.0 →</p> <p>3: 8.8 ↓</p> <p>4: 9.5 ←</p> <p>5: 9.2 ↓</p> <hr/> <p>Serie 45.0</p> <hr/> <p>Total 312.0</p>		
-------------------------	---	--	--

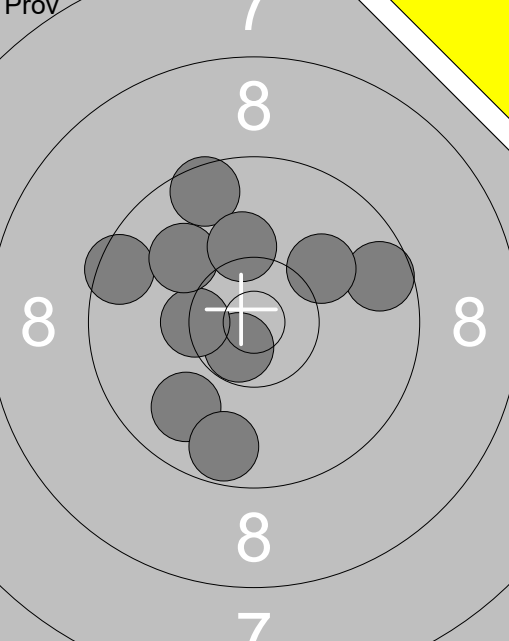
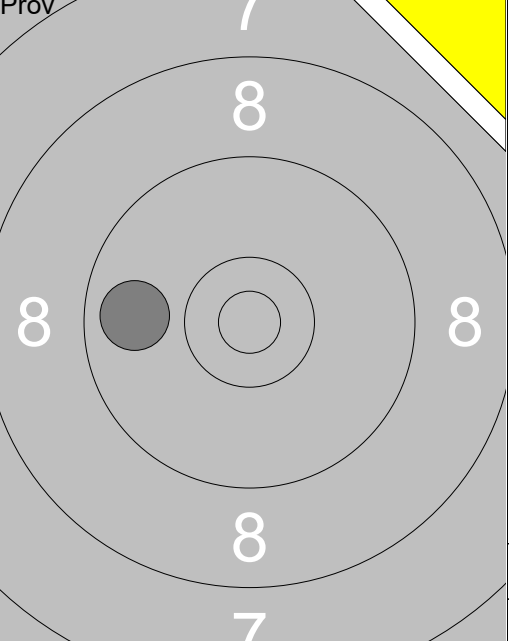
	<p>1: 9.9 ↙</p> <p>2: 9.7 ↓</p> <p>3: 10.7x ↘</p> <p>4: 9.5 ↖</p> <p>5: 9.6 ↑</p> <p>6: 10.4x ←</p> <p>7: 9.6 →</p> <p>8: 10.0 ↖</p> <p>9: 10.1 ↗</p> <p>10: 10.2 ↑</p>		<p>11: 9.8 ←</p>
Serie 95.0		Serie 9.0	
Total 179.0		Total 179.0	

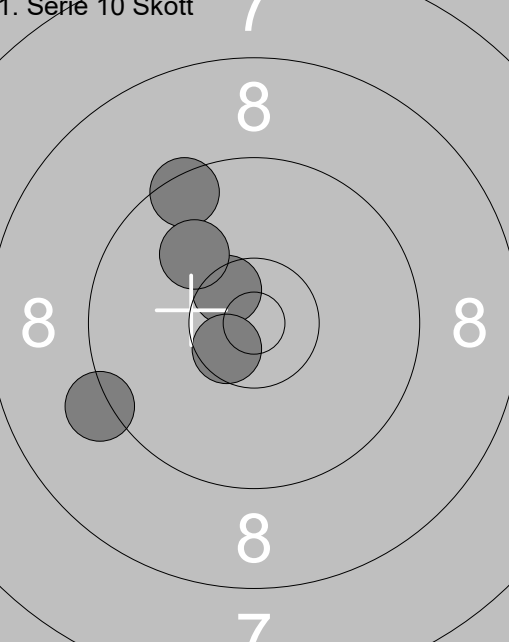
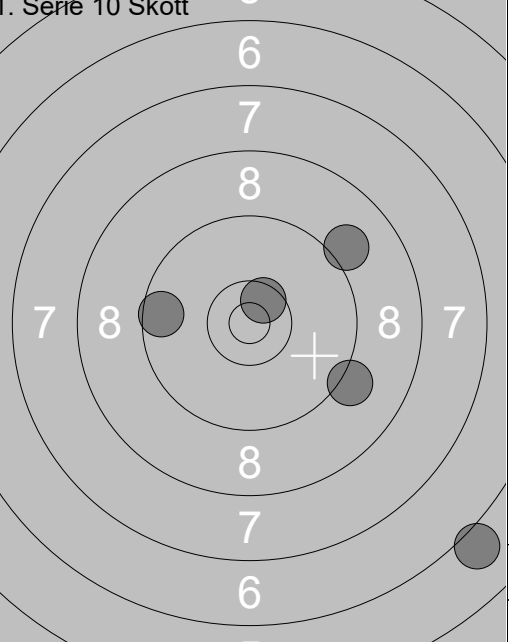
<p>1. Serie 10 Skott</p> 	<p>1: 9.5 ↖</p> <p>2: 9.2 ↙</p> <p>3: 10.5x ↘</p> <p>4: 10.6x ↘</p> <p>5: 10.0 ↖</p>	<p>1. Serie 10 Skott</p> 	<p>6: 9.2 ↘</p> <p>7: 10.5x ↗</p> <p>8: 9.6 ←</p> <p>9: 6.1 ↘</p> <p>10: 9.1 ↗</p>
Serie 48.0		Serie 43.0	
Total 227.0		Total 270.0	

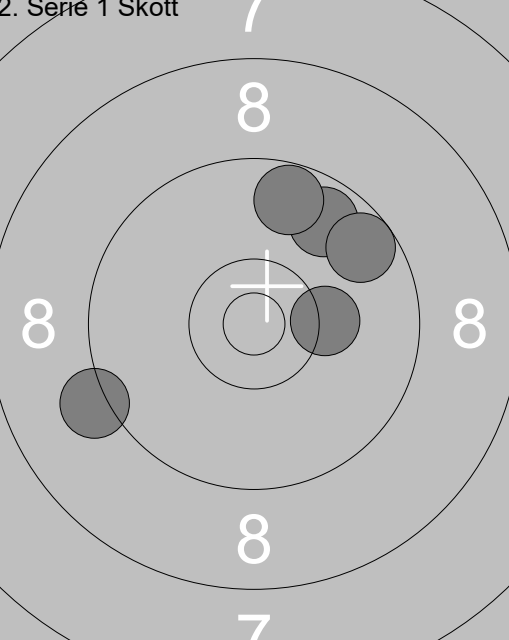
<p>2. Serie 1 Skott</p> 	<p>1: 9.7 ↗</p> <p>2: 9.2 ↙</p> <p>3: 9.7 ↑</p> <p>4: 10.2 →</p> <p>5: 9.6 ↗</p>		
Serie 46.0			
Total 316.0			

	<p>1: 9.4 ↙ 2: 8.5 ↓ 3: 9.5 ↖ 4: 10.6x→ 5: 8.7 → 6: 10.3→ 7: 9.4 ← 8: 10.4x→ 9: 9.9 ↘ 10: 9.8 ↘</p>		<p>11: 9.1 ↖ 12: 10.1 ↗ 13: 9.5 ↗ 14: 8.5 ↗ 15: 9.7 ↑</p>
Serie 91.0		Serie 45.0	
Total 179.0		Total 179.0	

<p>1. Serie 10 Skott</p>	<p>1: 9.6 → 2: 10.0← 3: 8.1 ← 4: 10.7x→ 5: 9.3 ←</p>		<p>6: 7.6 ↖ 7: 7.8 → 8: 9.7 ← 9: 9.4 ↑ 10: 8.9 ↗</p>
Serie 46.0		Serie 40.0	
Total 225.0		Total 265.0	

<p>2. Serie 1 Skott</p>	<p>1: 10.0 ↖ 2: 8.1 ↗ 3: 9.9 ↖ 4: 8.6 ↗ 5: 8.7 ↑</p>		
Serie 43.0			
Total 308.0			

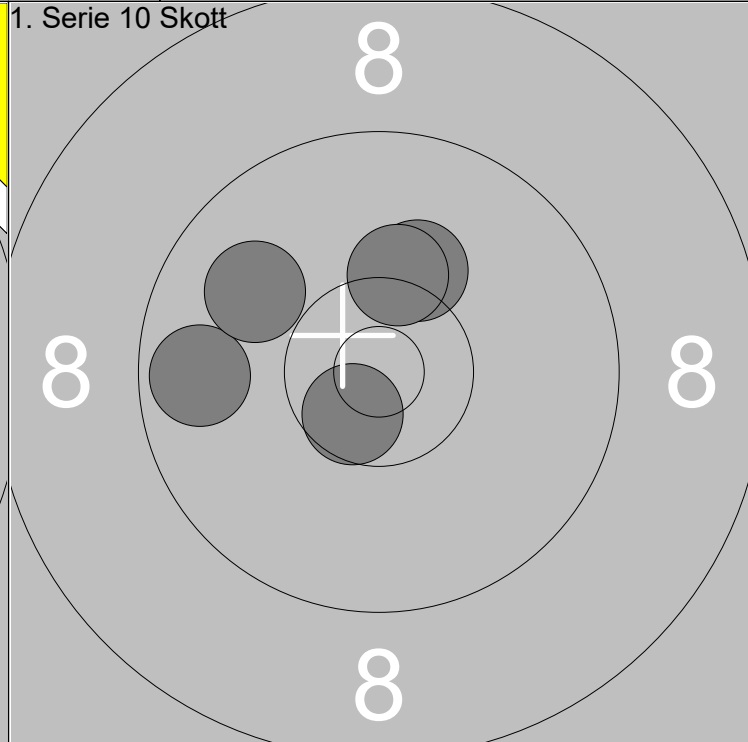
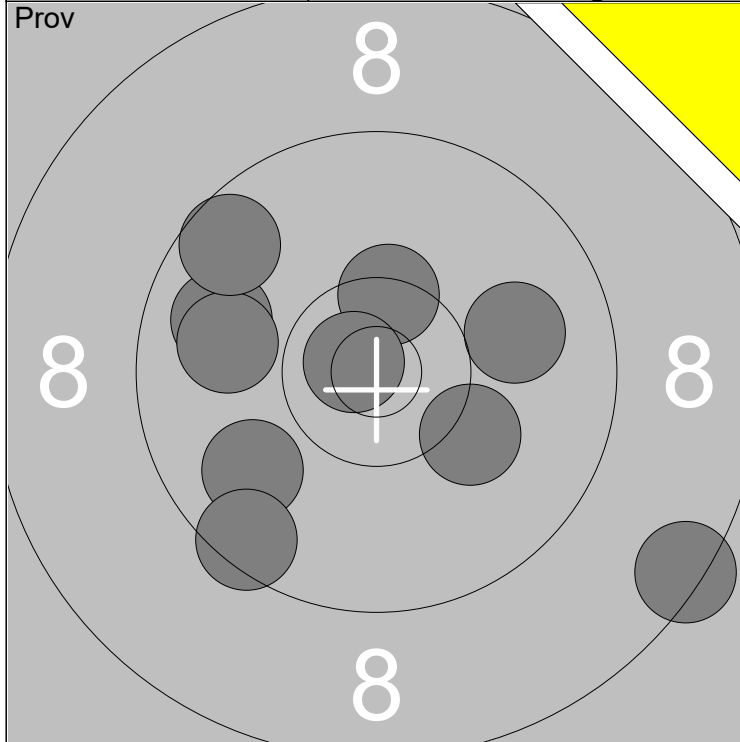

1: 9.9 ↙	6: 10.4x ↑	Serie	93
2: 9.5 ↘	7: 9.9 ←		
3: 8.4 ↘	8: 10.8x ←	Total	187
4: 9.8 ↙	9: 10.2 ↘		
5: 10.0 →	10: 9.6 ↖		

1: 9.7 ←	Serie	48
2: 10.6x ↘		
3: 10.2 ↑	Total	235
4: 9.9 ↙		
5: 10.3 ↑		

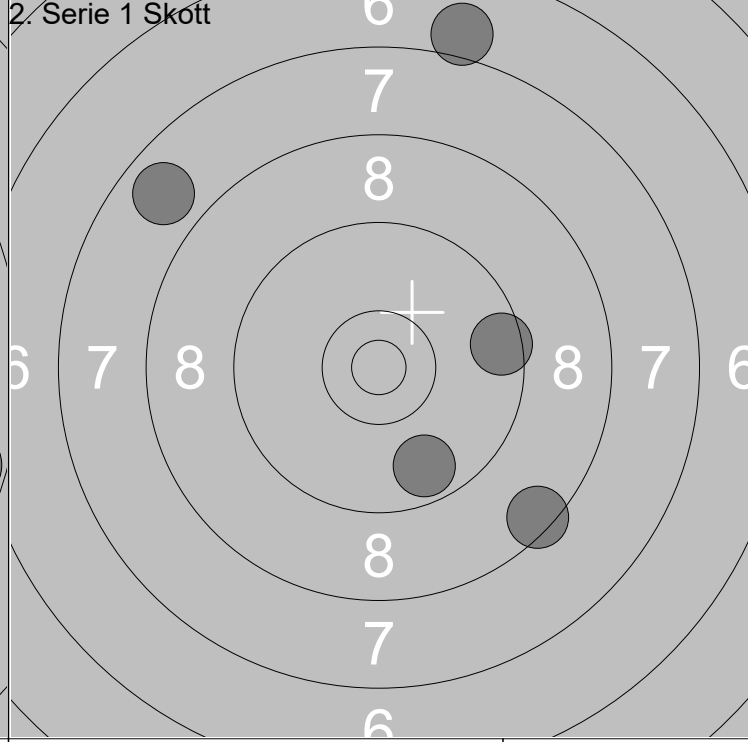
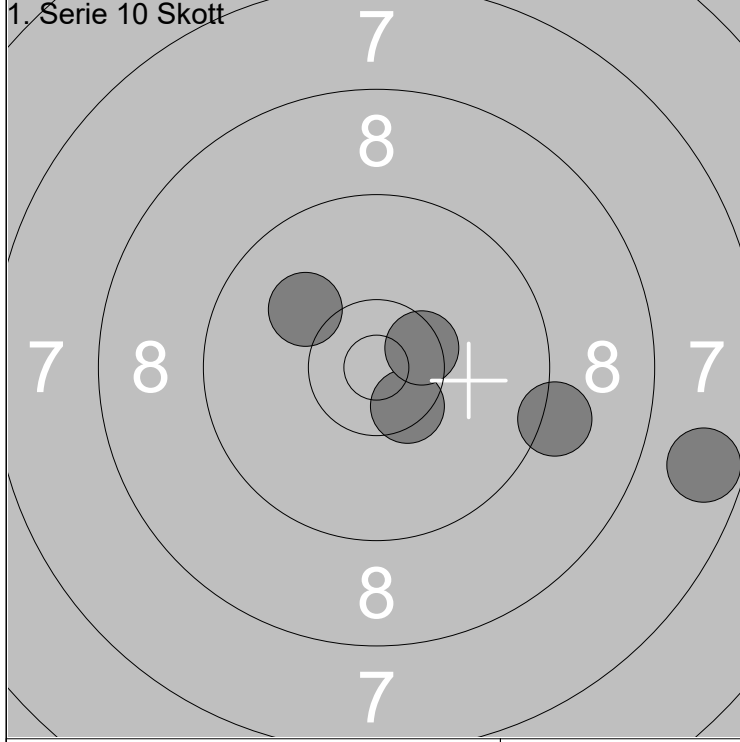

6: 7.7 →	Serie	46
7: 10.5x ↘		
8: 9.2 ↘	Total	281
9: 10.1 ↖		
10: 10.5x →		

1: 8.5 ↘	Serie	40
2: 9.5 →		
3: 7.8 ↖	Total	321
4: 7.0 ↑		
5: 9.7 ↘		

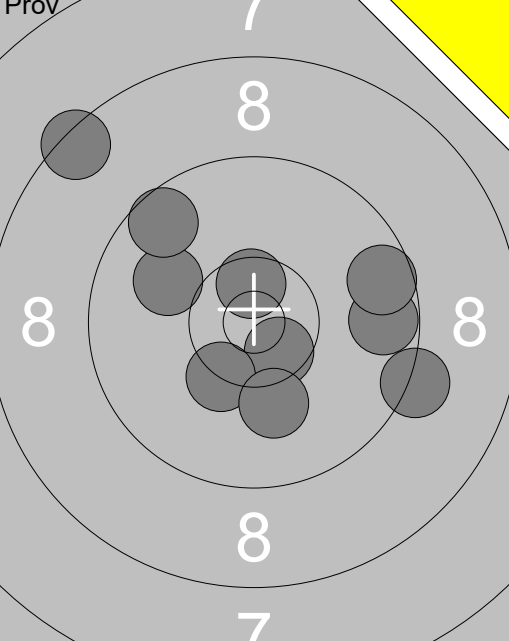
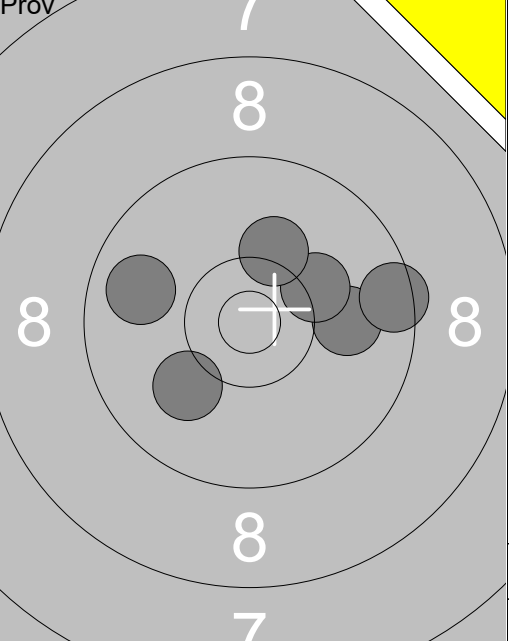
	<p>Prov</p> <ol style="list-style-type: none"> 1: 8.4 ↗ 2: 10.0 ↖ 3: 10.6x ↘ 4: 9.6 ↗ 5: 9.2 → 6: 9.7 → 7: 10.3x ↙ 8: 10.1 ↓ 9: 9.6 → 10: 10.6x ↗ <table border="1" style="width:100%; border-collapse: collapse; margin-top: 5px;"> <tr><td style="text-align: right;">Serie</td><td style="text-align: right;">94.0</td></tr> <tr><td style="text-align: right;">Total</td><td style="text-align: right;">187.0</td></tr> </table>	Serie	94.0	Total	187.0		<p>Prov</p> <ol style="list-style-type: none"> 11: 10.0 → 12: 9.5 → 13: 10.2 → 14: 10.2 ↗ 15: 10.1 ↙ 16: 9.8 ↖ <table border="1" style="width:100%; border-collapse: collapse; margin-top: 5px;"> <tr><td style="text-align: right;">Serie</td><td style="text-align: right;">58.0</td></tr> <tr><td style="text-align: right;">Total</td><td style="text-align: right;">187.0</td></tr> </table>	Serie	58.0	Total	187.0
Serie	94.0										
Total	187.0										
Serie	58.0										
Total	187.0										

<p>1. Serie 10 Skott</p> 	<ol style="list-style-type: none"> 1: 10.8x → 2: 10.6x ↘ 3: 10.1 → 4: 10.6x → 5: 9.3 → <table border="1" style="width:100%; border-collapse: collapse; margin-top: 5px;"> <tr><td style="text-align: right;">Serie</td><td style="text-align: right;">49.0</td></tr> <tr><td style="text-align: right;">Total</td><td style="text-align: right;">236.0</td></tr> </table>	Serie	49.0	Total	236.0	<p>1. Serie 10 Skott</p> 	<ol style="list-style-type: none"> 6: 7.9 ↖ 7: 10.4x ↗ 8: 9.3 → 9: 8.6 ↓ 10: 8.2 ↗ <table border="1" style="width:100%; border-collapse: collapse; margin-top: 5px;"> <tr><td style="text-align: right;">Serie</td><td style="text-align: right;">42.0</td></tr> <tr><td style="text-align: right;">Total</td><td style="text-align: right;">278.0</td></tr> </table>	Serie	42.0	Total	278.0
Serie	49.0										
Total	236.0										
Serie	42.0										
Total	278.0										

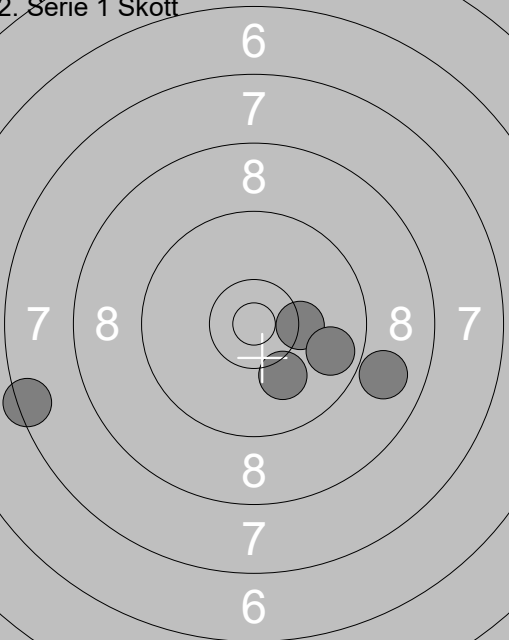
<p>2. Serie 1 Skott</p> 	<ol style="list-style-type: none"> 1: 10.1 ↓ 2: 8.9 → 3: 10.3 → 4: 7.4 ↖ 5: 9.8 → <table border="1" style="width:100%; border-collapse: collapse; margin-top: 5px;"> <tr><td style="text-align: right;">Serie</td><td style="text-align: right;">44.0</td></tr> <tr><td style="text-align: right;">Total</td><td style="text-align: right;">322.0</td></tr> </table>	Serie	44.0	Total	322.0		
Serie	44.0						
Total	322.0						

	<p>1: 10.0 →</p> <p>2: 9.7 ↘</p> <p>3: 9.4 →</p> <p>4: 10.1 →</p> <p>5: 10.2 ↖</p> <p>6: 9.1 ↘</p> <p>7: 10.2 ↘</p> <p>8: 9.9 ↘</p> <p>9: 10.3x →</p> <p>10: 10.1 ←</p>	<p>11: 10.1 ←</p> <p>12: 10.0 ↑</p> <p>13: 10.4x ↘</p> <p>14: 10.5x ↘</p>
Serie 96.0		Serie 40.0
Total 187.0		Total 187.0

<p>1. Serie 10 Skott</p>	<p>1: 10.0 →</p> <p>2: 10.1 ↘</p> <p>3: 10.2 ←</p> <p>4: 9.9 ↘</p> <p>5: 9.5 ↘</p>	<p>6: 10.6x ↗</p> <p>7: 8.1 ←</p> <p>8: 10.4x ↘</p> <p>9: 9.7 →</p> <p>10: 10.2 →</p>
Serie 48.0		Serie 47.0
Total 235.0		Total 282.0

<p>2. Serie 1 Skott</p>	<p>1: 5.5 ↘</p> <p>2: 8.4 ↓</p> <p>3: 8.1 →</p> <p>4: 8.5 ↘</p> <p>5: 8.6 ↘</p>	
Serie 37.0		
Total 319.0		

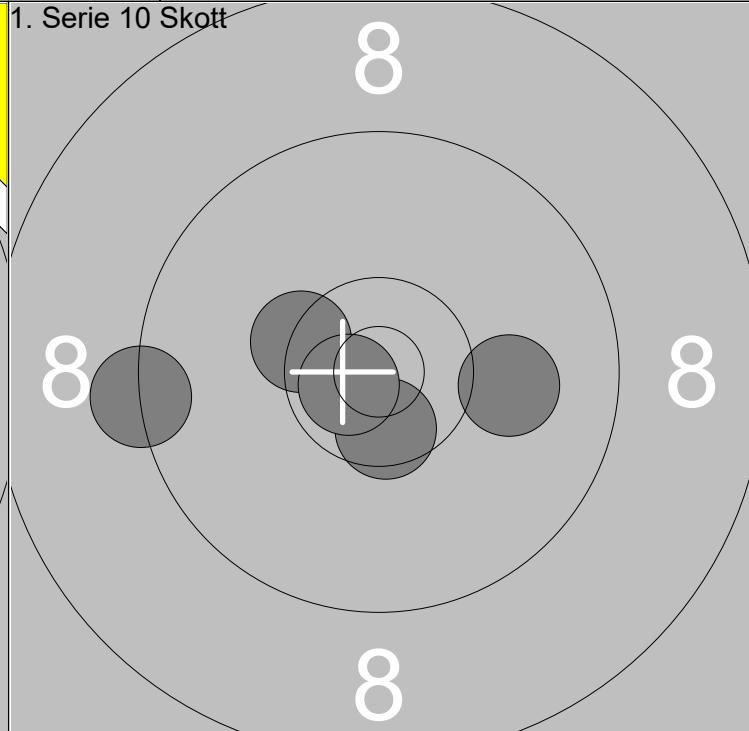
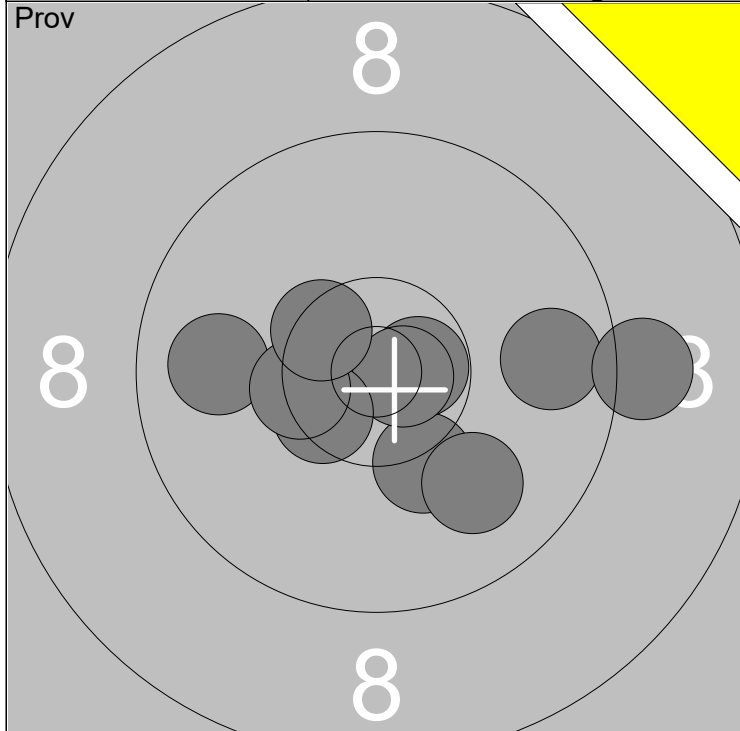

1: 10.2 ↘	6: 10.7x →	Serie	96
2: 9.9 ←	7: 10.8x →		
3: 9.7 →	8: 10.5x ↙	Total	186
4: 9.1 →	9: 10.4x ←		
5: 9.9 ↘	10: 10.5x ↖		

1: 10.1 →		Serie	49
2: 10.4x ↖			
3: 10.6x ↘		Total	235
4: 9.3 ←			
5: 10.7x ↖			

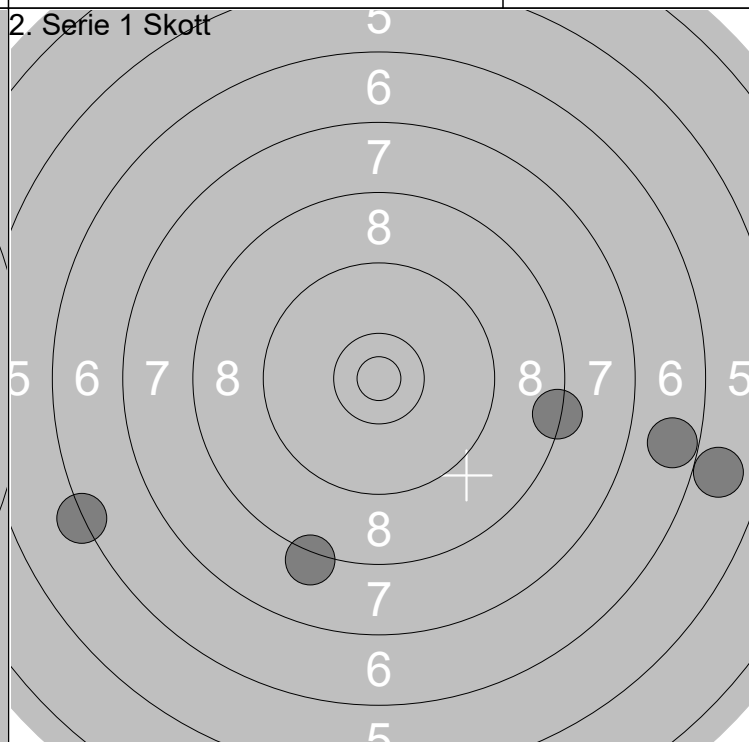
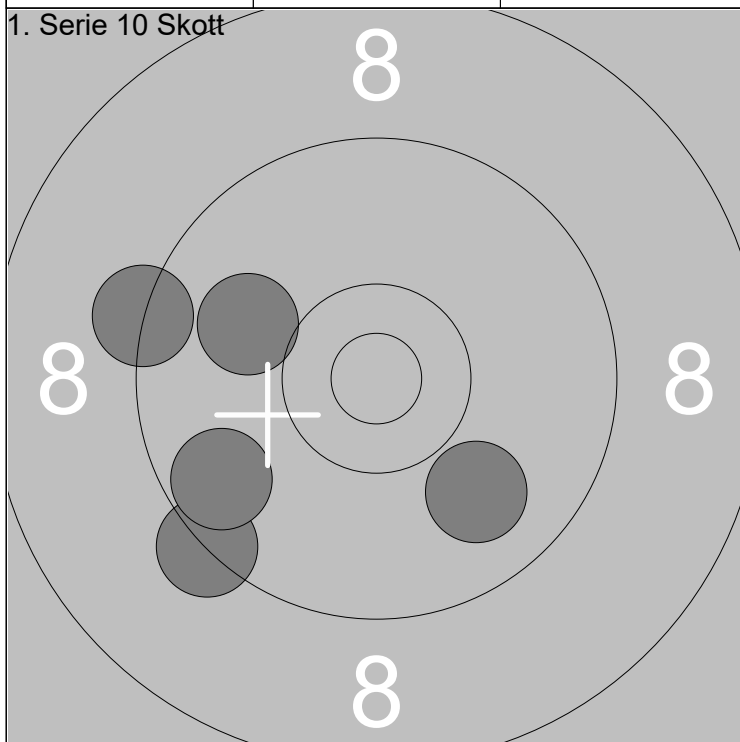

6: 9.3 ↙		Serie	46
7: 10.0 ↖			
8: 9.9 ↘		Total	281
9: 9.7 ↖			
10: 9.3 ←			

1: 8.4 →		Serie	33
2: 5.9 →			
3: 6.3 ↖		Total	314
4: 8.2 ↘			
5: 6.7 →			

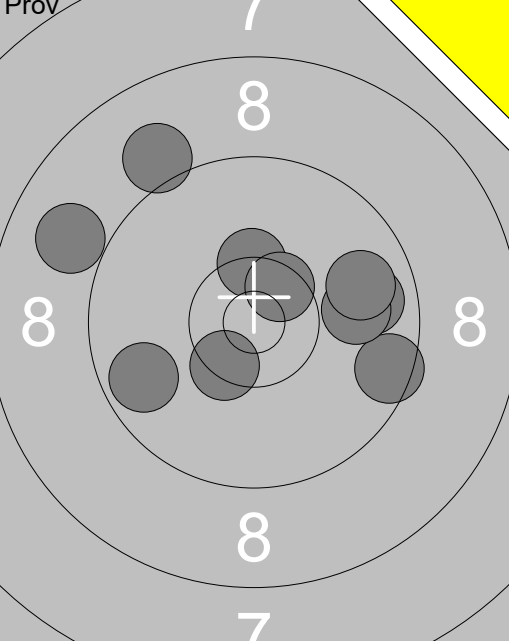
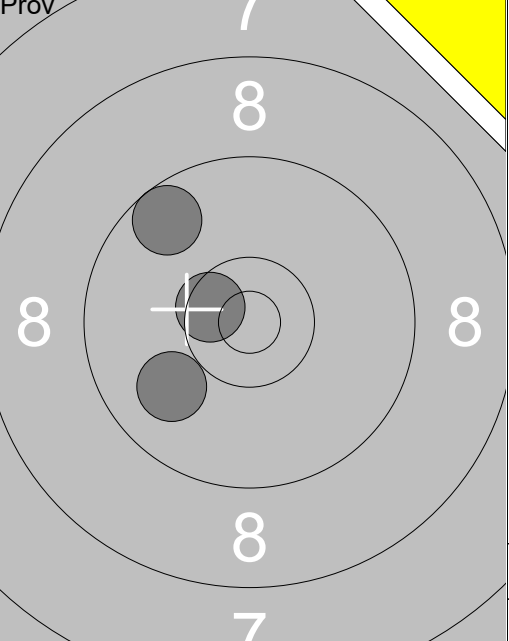
	<p>1: 8.9 ↙</p> <p>2: 10.4x↑</p> <p>3: 9.0 ↗</p> <p>4: 9.8 →</p> <p>5: 9.5 →</p> <p>6: 9.9 →</p> <p>7: 10.5x↗</p> <p>8: 10.4x↘</p> <p>9: 9.7 ↙</p> <p>10: 9.8 →</p>		<p>11: 9.6 ↖</p> <p>12: 9.9 ↙</p> <p>13: 10.5x↘</p>
Serie	92.0	Serie	28.0
Total	186.0	Total	186.0

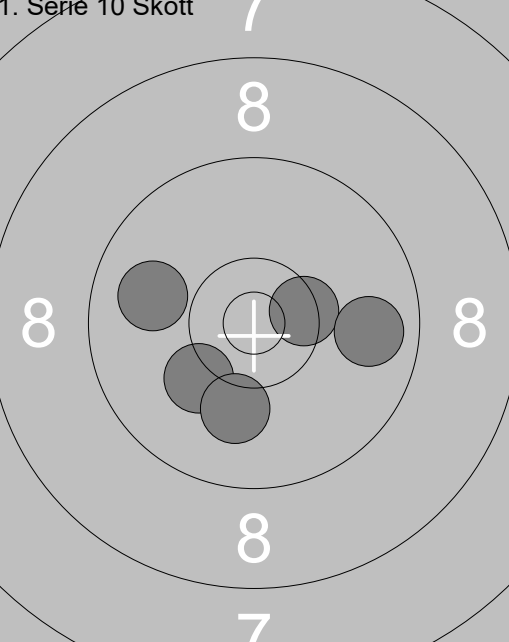
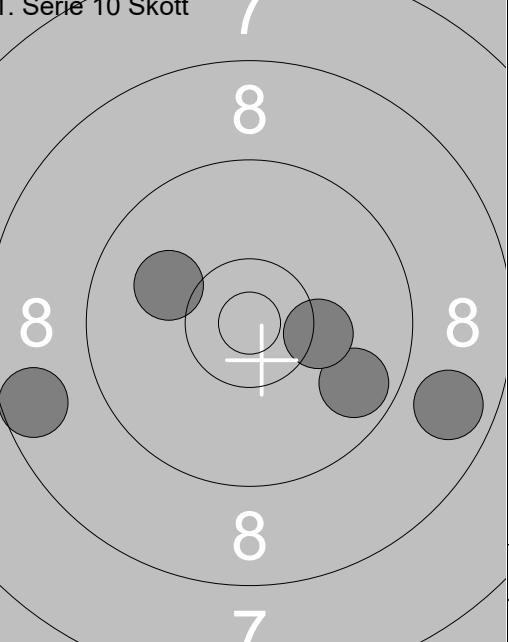
<p>1. Serie 10 Skott</p> 	<p>1: 10.4x→</p> <p>2: 9.8 →</p> <p>3: 9.9 ↙</p> <p>4: 10.2↘</p> <p>5: 10.1 ↓</p>	<p>1. Serie 10 Skott</p> 	<p>6: 8.8 →</p> <p>7: 9.7 ↘</p> <p>8: 10.1↖</p> <p>9: 10.2→</p> <p>10: 8.6 ↙</p>
Serie	48.0	Serie	45.0
Total	234.0	Total	279.0

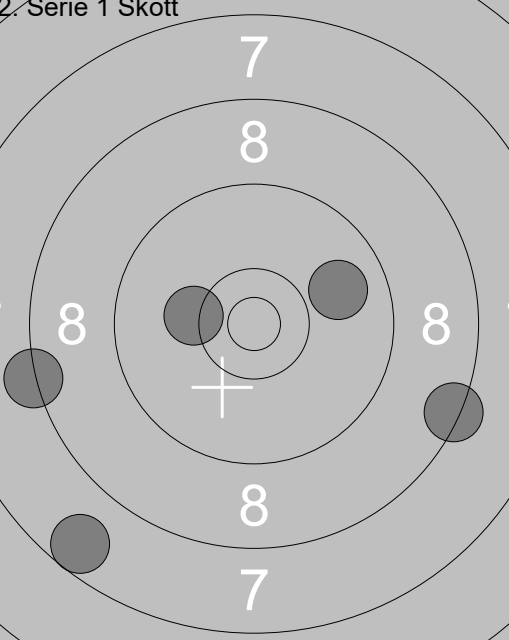
<p>2. Serie 1 Skott</p> 	<p>1: 10.2↖</p> <p>2: 9.9 →</p> <p>3: 8.3 ↙</p> <p>4: 8.4 →</p> <p>5: 7.6 ↘</p>		
Serie	42.0		
Total	321.0		

	<p>1: 7.3 ←</p> <p>2: 9.8 ↑</p> <p>3: 8.2 ↖</p> <p>4: 10.0 ↙</p> <p>5: 10.0 ↘</p> <p>6: 10.1 ↗</p> <p>7: 10.3 ✖</p> <p>8: 9.8 ↖</p> <p>9: 10.2 ↖</p> <p>10: 10.6 ✖↑</p>	<p>11: 10.6 ✖</p> <p>12: 10.3 ↖</p> <p>13: 10.1 ↖</p> <p>14: 10.0 ↖</p> <p>15: 9.8 →</p>
Serie 93.0		Serie 49.0
Total 186.0		Total 186.0

<p>1. Serie 10 Skott</p>	<p>1: 10.6 ✖↗</p> <p>2: 10.1 ↓</p> <p>3: 10.6 ✖→</p> <p>4: 9.5 ↑</p> <p>5: 9.9 ←</p>	<p>1. Serie 10 Skott</p> <p>6: 8.8 ↖</p> <p>7: 6.0 ↙</p> <p>8: 10.3 ✖</p> <p>9: 10.6 ✖</p> <p>10: 8.4 →</p>
Serie 48.0		Serie 42.0
Total 234.0		Total 276.0

<p>2. Serie 1 Skott</p>	<p>1: 9.0 ↙</p> <p>2: 8.8 ↖</p> <p>3: 9.0 →</p> <p>4: 8.6 ←</p> <p>5: 9.3 →</p>	
Serie 43.0		
Total 319.0		

	<p>1: 9.7 ↘</p> <p>2: 8.8 ↘</p> <p>3: 10.6x↘</p> <p>4: 10.8x↘</p> <p>5: 8.7 ↘</p> <p>6: 9.0 ↘</p> <p>7: 10.0 ↘</p> <p>8: 10.0 →</p> <p>9: 10.0 →</p> <p>10: 10.1 ↘</p>	<p>11: 10.0 ↗</p>
Serie 94.0		Serie 10.0
Total 185.0		Total 185.0

<p>1. Serie 10 Skott</p>	<p>1: 9.6 ↗</p> <p>2: 10.3 ↖</p> <p>3: 10.0 ↗</p> <p>4: 10.4x↗</p> <p>5: 8.6 ↘</p>	<p>6: 10.9x↘</p> <p>7: 9.3 ↘</p> <p>8: 10.3x→</p> <p>9: 8.7 ↘</p> <p>10: 10.2 →</p>
Serie 47.0		Serie 47.0
Total 232.0		Total 279.0

<p>2. Serie 1 Skott</p>	<p>1: 6.6 ↘</p> <p>2: 9.3 ↗</p> <p>3: 9.2 ↘</p> <p>4: 6.0 →</p> <p>5: 9.2 ↘</p>	
Serie 39.0		
Total 318.0		

Prov 	1: 8.5 ← 2: 10.2 → 3: 8.5 ← 4: 9.4 → 5: 10.4x ↘ 6: 9.7 ↓ 7: 9.5 ↓ 8: 10.1 ← 9: 8.7 ← 10: 9.5 ↗	Prov 		11: 9.5 ↗ 12: 9.0 ←
Serie 90.0				Serie 18.0
Total 184.0				Total 184.0

1. Serie 10 Skott 	1: 9.8 → 2: 10.3x ↗ 3: 10.5x ↘ 4: 9.3 ↗ 5: 10.1 ←	1. Serie 10 Skott 		6: 10.6x ↘ 7: 10.6x ↗ 8: 10.0 ← 9: 9.6 ↗ 10: 9.3 ↘
Serie 48.0				Serie 48.0
Total 232.0				Total 280.0

2. Serie 1 Skott 	1: 8.0 ↗ 2: 9.7 ← 3: 8.0 ↓ 4: 7.9 ↓ 5: 7.2 →			
Serie 39.0				
Total 319.0				

<p>Prov</p>	<p>1: 7.4 ↘ 2: 10.4x ↘ 3: 9.7 ↘ 4: 9.2 ↓ 5: 9.5 ↙ 6: 9.0 ↘ 7: 8.3 ↘ 8: 9.7 ↘ 9: 9.8 → 10: 9.3 ↘</p> <p>Serie 88.0 Total 183.0</p>	<p>Prov</p>	<p>11: 10.2 → 12: 10.4x ↘ 13: 10.4x ↗ 14: 9.7 ↗ 15: 9.8 → 16: 10.2 ← 17: 10.8x ↗ 18: 9.7 ↖ 19: 10.5x ↘</p> <p>Serie 87.0 Total 183.0</p>
-------------	---	-------------	---

<p>1. Serie 10 Skott</p>	<p>1: 10.4x ↘ 2: 9.6 → 3: 9.7 ↗ 4: 10.7x ↘ 5: 10.3x ↘</p> <p>Serie 48.0 Total 231.0</p>	<p>1. Serie 10 Skott</p>	<p>6: 10.0 → 7: 9.3 ↑ 8: 9.8 ↓ 9: 10.7x → 10: 9.8 ←</p> <p>Serie 47.0 Total 278.0</p>
--------------------------	--	--------------------------	--

<p>2. Serie 1 Skott</p>	<p>1: 8.0 ↓ 2: 8.5 ← 3: 8.8 ← 4: 10.6x ↘ 5: 6.8 →</p> <p>Serie 40.0 Total 318.0</p>		
-------------------------	--	--	--

	<p>1: 8.5 ↙ 2: 9.2 ↙ 3: 8.8 ↙ 4: 9.8 ↘ 5: 10.2 ↑ 6: 9.2 → 7: 9.0 ↗ 8: 10.3x ↘ 9: 10.0 → 10: 9.1 ↑</p>	<p style="text-align: right;">11: 10.5x ↗</p>
Serie 91.0		Serie 10.0
Total 183.0		Total 183.0

<p>1. Serie 10 Skott</p>	<p>1: 10.2 ↑ 2: 10.7x ↘ 3: 9.6 ↓ 4: 10.7x → 5: 10.8x ↘</p>	<p style="text-align: right;">6: 9.9 ↗ 7: 10.6x ↗ 8: 10.7x ↗ 9: 8.8 ← 10: 9.7 ↗</p>
Serie 49.0		Serie 46.0
Total 232.0		Total 278.0

<p>2. Serie 1 Skott</p>	<p>1: 9.6 → 2: 8.8 → 3: 9.7 ↗ 4: 8.1 → 5: 8.7 ←</p>	
Serie 42.0		
Total 320.0		

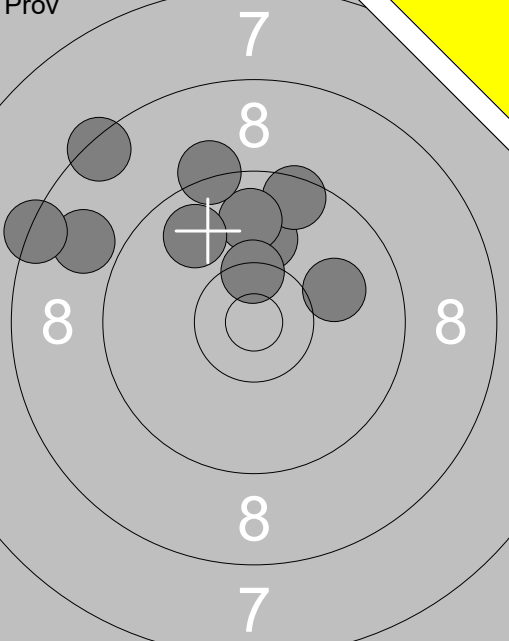
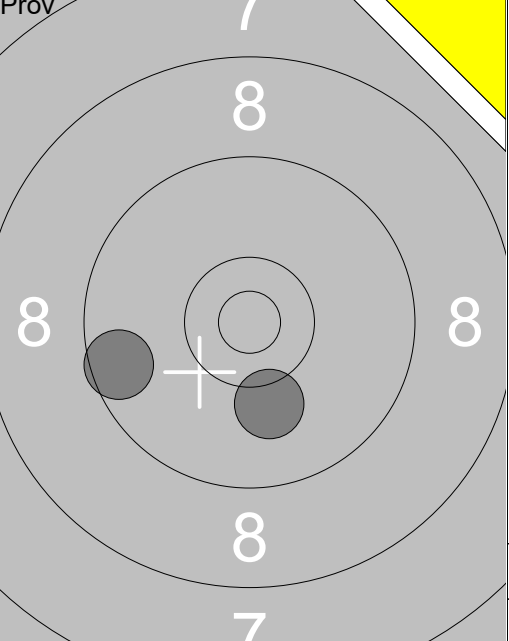
	<p>Prov</p> <p>1: 10.0 ↑</p> <p>2: 8.9 ↙</p> <p>3: 8.4 ↘</p> <p>4: 9.5 ↑</p> <p>5: 10.0 →</p> <p>6: 9.8 ↑</p> <p>7: 9.2 ↑</p> <p>8: 9.8 ↘</p> <p>9: 10.4x↑</p> <p>10: 8.4 ↙</p>		<p>11: 10.1 ↓</p> <p>12: 9.6 ↙</p>
Serie 90.0		Serie 19.0	
Total 183.0		Total 183.0	

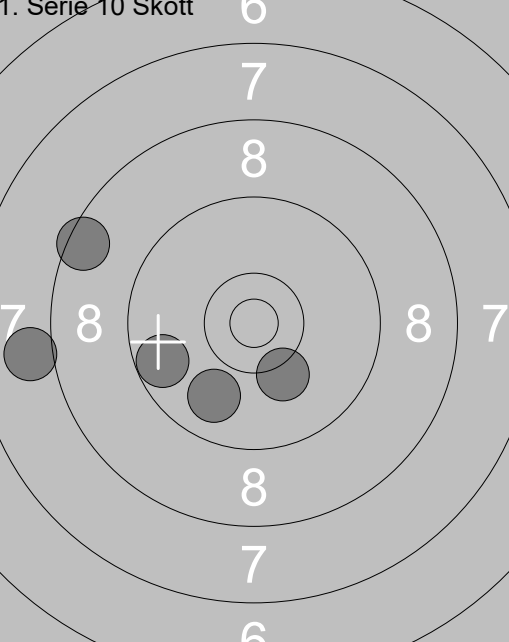
<p>1. Serie 10 Skott</p> 	<p>1: 8.5 ↙</p> <p>2: 9.7 ↙</p> <p>3: 9.9 ↓</p> <p>4: 8.0 ↙</p> <p>5: 10.2 ↓</p>	<p>1. Serie 10 Skott</p> 	<p>6: 9.9 ↓</p> <p>7: 9.6 ↙</p> <p>8: 10.0 ↘</p> <p>9: 10.7x→</p> <p>10: 5.3 →</p>
Serie 44.0		Serie 43.0	
Total 227.0		Total 270.0	

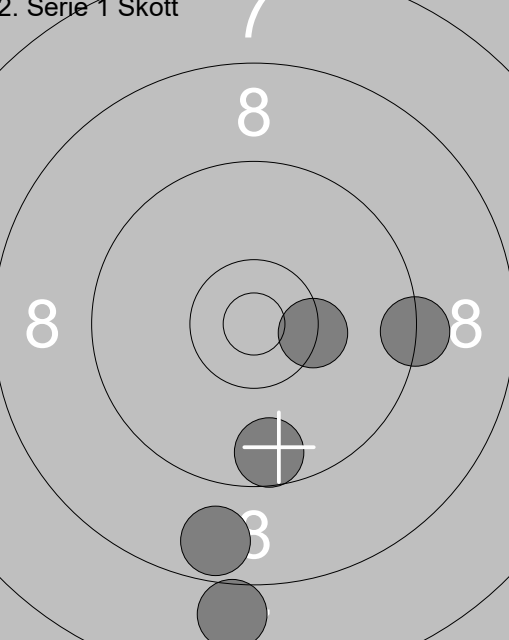
<p>2. Serie 1 Skott</p> 	<p>1: 9.6 ↓</p> <p>2: 8.7 ↓</p> <p>3: 9.3 →</p> <p>4: 10.3x→</p> <p>5: 8.0 ↓</p>		
Serie 44.0			
Total 314.0			

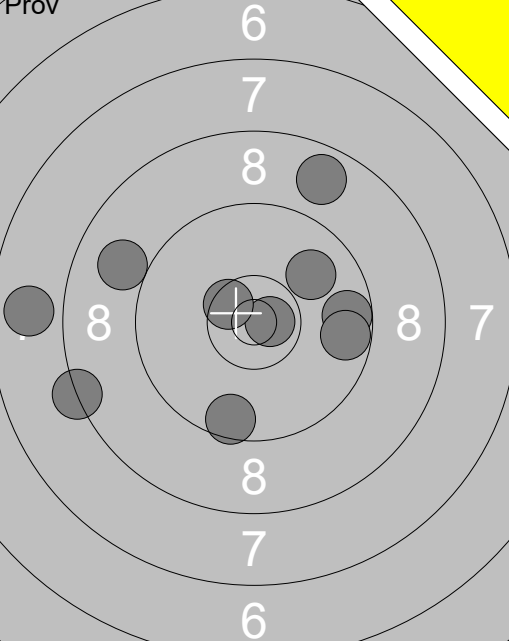
	<p>1: 9.6 ↓</p> <p>2: 8.3 ←</p> <p>3: 9.0 ←</p> <p>4: 7.8 ←</p> <p>5: 8.8 ↑</p> <p>6: 9.7 →</p> <p>7: 9.7 →</p> <p>8: 10.7x→</p> <p>9: 9.9 ↗</p> <p>10: 10.5x↘</p>	<p>11: 9.1 ↗</p> <p>12: 10.4x↑</p> <p>13: 10.4x↑</p> <p>14: 9.3 →</p>
Serie 88.0		Serie 38.0
Total 183.0		Total 183.0

<p>1. Serie 10 Skott</p> 	<p>1: 10.3x↑</p> <p>2: 9.6 →</p> <p>3: 8.9 →</p> <p>4: 8.0 →</p> <p>5: 10.3 ↗</p>	<p>6: 7.6 ↖</p> <p>7: 8.4 →</p> <p>8: 10.1→</p> <p>9: 10.5x↘</p> <p>10: 0.0</p>
Serie 45.0		Serie 35.0
Total 228.0		Total 263.0

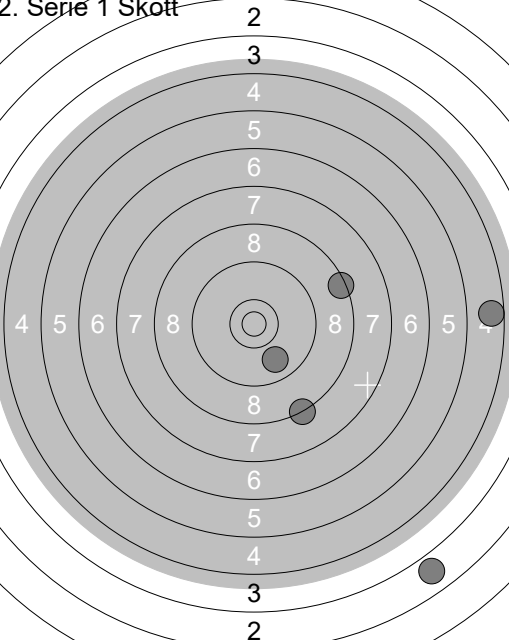
<p>2. Serie 1 Skott</p> 	<p>1: 2.9 ↓</p> <p>2: 8.4 →</p> <p>3: 9.9 ↓</p> <p>4: 4.6 →</p> <p>5: 8.3 ↓</p>	
Serie 31.0		
Total 294.0		

	<p>1: 9.4 ↖</p> <p>2: 8.8 ←</p> <p>3: 8.8 ←</p> <p>4: 10.2 ↑</p> <p>5: 9.7 ←</p> <p>6: 10.1 ↖</p> <p>7: 9.7 →</p> <p>8: 10.5x ↗</p> <p>9: 9.8 ↑</p> <p>10: 10.4x ↘</p>		<p>11: 10.3x ↘</p>
Serie 92.0		Serie 10.0	
Total 182.0		Total 182.0	

<p>1. Serie 10 Skott</p>	<p>1: 10.5x →</p> <p>2: 9.6 ↖</p> <p>3: 9.6 ←</p> <p>4: 9.8 ↖</p> <p>5: 10.5x ↘</p>		<p>6: 9.8 ↘</p> <p>7: 8.4 →</p> <p>8: 9.9 ↗</p> <p>9: 10.9x ↘</p> <p>10: 8.7 ↗</p>
Serie 47.0		Serie 44.0	
Total 229.0		Total 273.0	

<p>2. Serie 1 Skott</p>	<p>1: 8.4 ↗</p> <p>2: 8.8 ←</p> <p>3: 9.7 ←</p> <p>4: 9.1 →</p> <p>5: 6.6 →</p>		
Serie 40.0			
Total 313.0			

<p>Prov</p>	<p>1: 10.0 ↙ 2: 10.1 ↗ 3: 9.2 → 4: 10.0 → 5: 7.7 → 6: 10.5x→ 7: 10.0 ↖ 8: 10.1 ↖ 9: 9.7 ↙ 10: 9.7 ↙</p>	<p>Prov</p>	<p>11: 8.6 → 12: 10.4x↗</p>
Serie 94.0		Serie 18.0	
Total 181.0		Total 181.0	

<p>1. Serie 10 Skott</p>	<p>1: 9.3 ↘ 2: 9.9 ↖ 3: 9.6 → 4: 10.2 ↙ 5: 9.5 →</p>	<p>1. Serie 10 Skott</p>	<p>6: 10.5x→ 7: 10.2 ↗ 8: 9.2 ↗ 9: 7.5 ↗ 10: 8.6 ↖</p>
Serie 46.0		Serie 44.0	
Total 227.0		Total 271.0	

<p>2. Serie 1 Skott</p>	<p>1: 7.4 ↘ 2: 8.5 → 3: 10.3x← 4: 7.2 ↗ 5: 10.0 ↗</p>		
Serie 42.0			
Total 313.0			

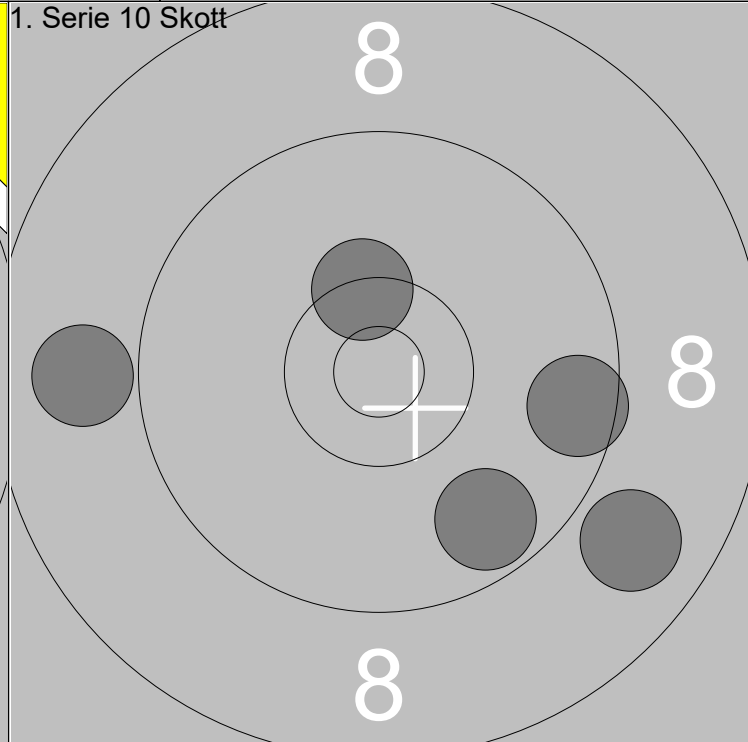
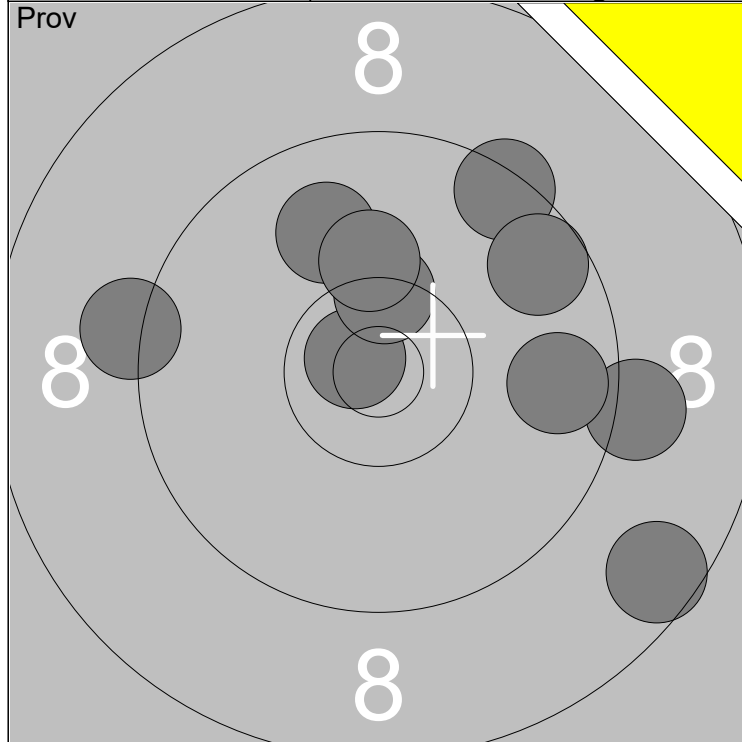

1: 10.8x ↙	6: 9.7 →	Serie	92
2: 9.9 ↗	7: 9.6 ↗		
3: 9.4 ↗	8: 10.4x ↑	Total	181
4: 8.6 ↘	9: 10.2 ↑		
5: 9.2 →	10: 9.2 ←		

1: 8.9 ↘	Serie	44
2: 9.7 ↘		
3: 10.4x ↑	Total	225
4: 9.6 →		
5: 8.9 ←		

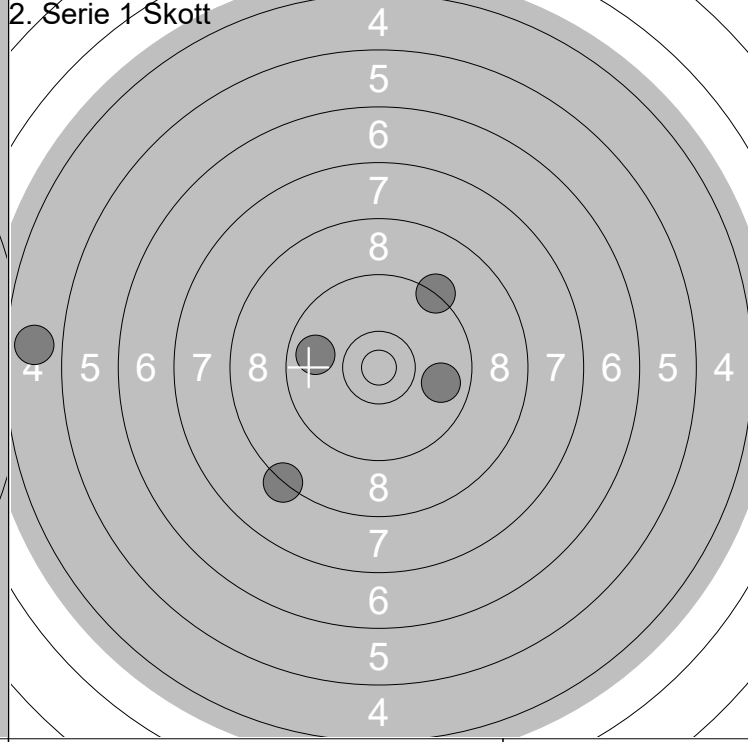
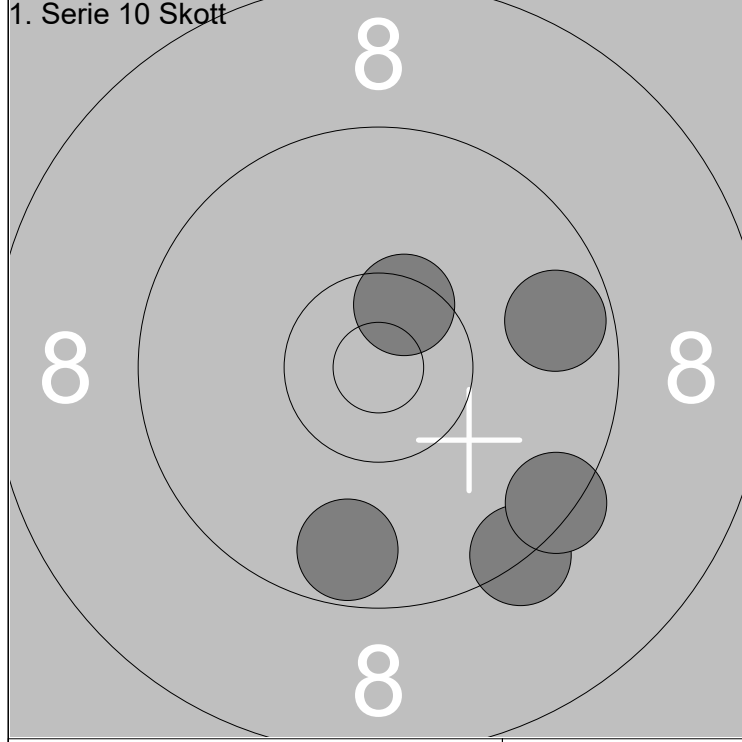

6: 10.5x ↑	Serie	46
7: 9.3 ↘		
8: 9.7 ↘	Total	271
9: 9.7 →		
10: 9.4 ↘		

1: 9.8 ←	Serie	39
2: 9.8 →		
3: 4.8 ←	Total	310
4: 8.3 ↙		
5: 9.3 ↗		

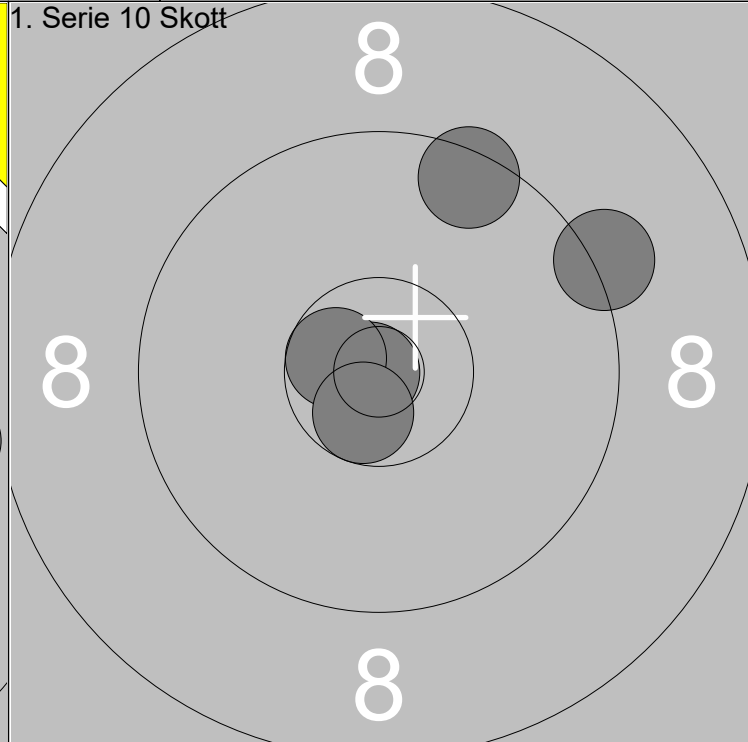
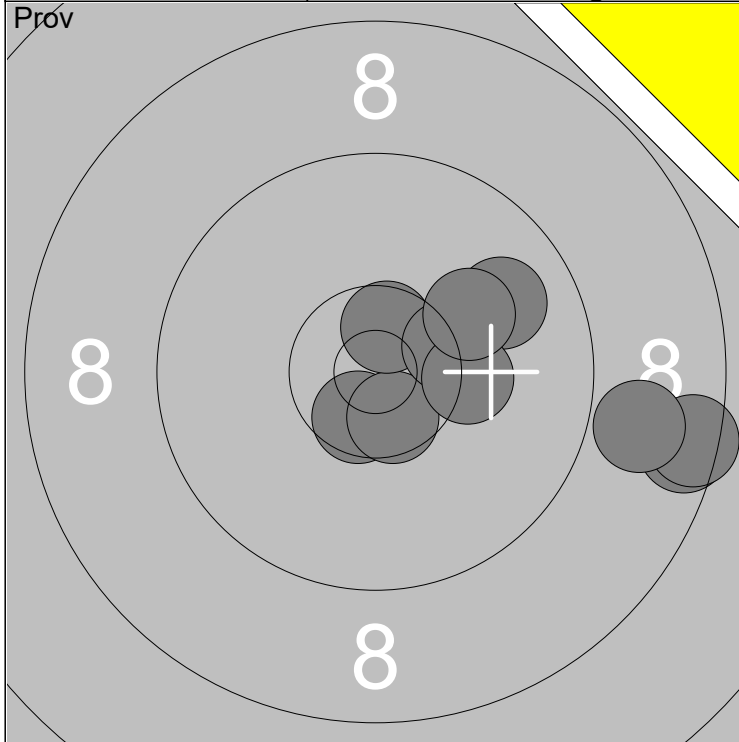

1: 8.6 →	6: 10.4x →	Serie	93
2: 10.6x ↓	7: 9.9 ↗		
3: 10.6x ↓	8: 10.3 →	Total	180
4: 10.6x ↑	9: 8.9 →		
5: 8.5 →	10: 10.1 ↗		

1: 10.9x ←	Serie	48
2: 9.5 ↗		
3: 10.6x ←	Total	228
4: 9.2 ↗		
5: 10.6x ↓		

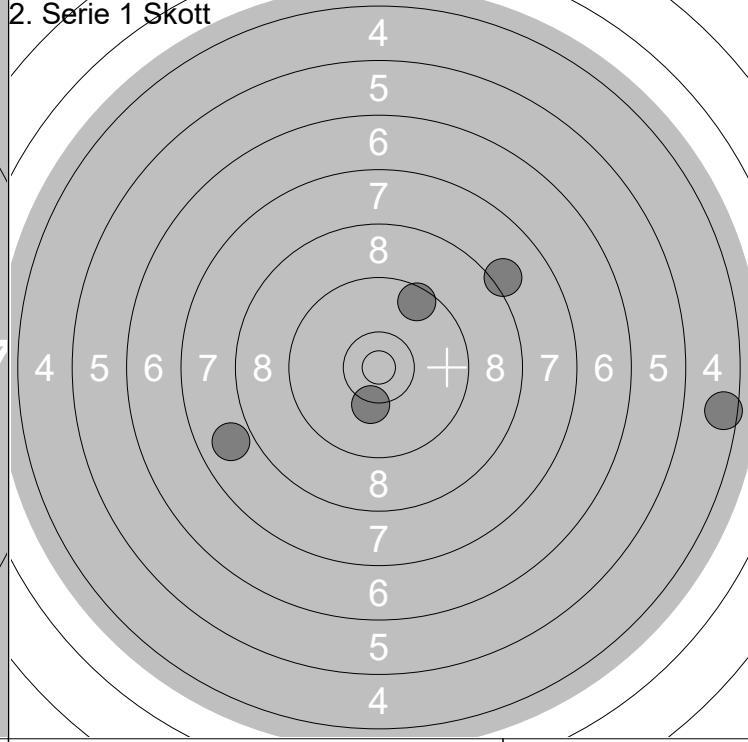
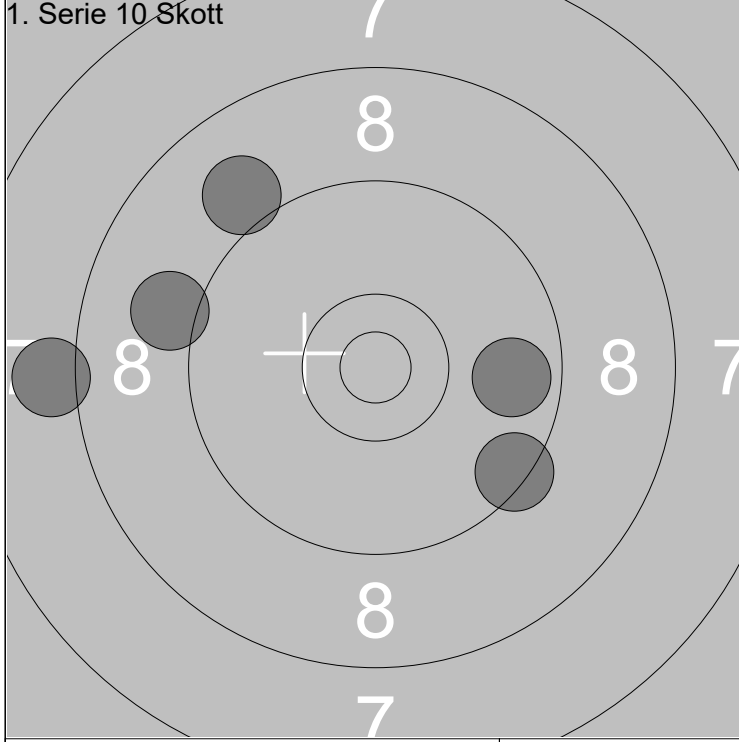

6: 9.7 →	Serie	44
7: 8.1 ←		
8: 9.1 ←	Total	272
9: 9.0 ↗		
10: 9.4 ↓		

1: 9.5 ↗	Serie	38
2: 8.1 ↗		
3: 7.9 ←	Total	310
4: 10.2 ↓		
5: 4.5 →		

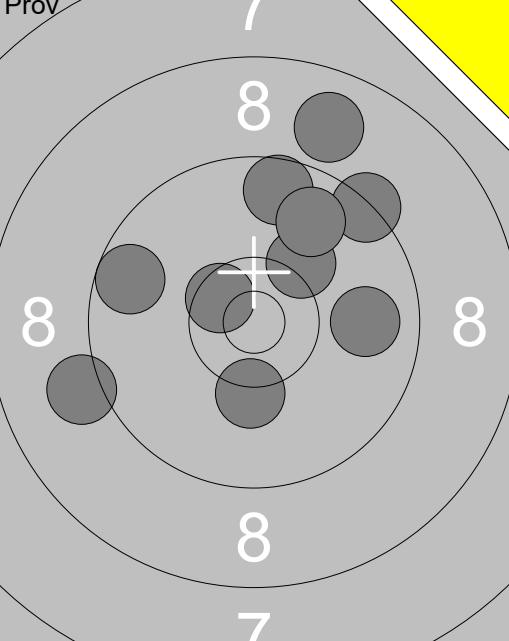
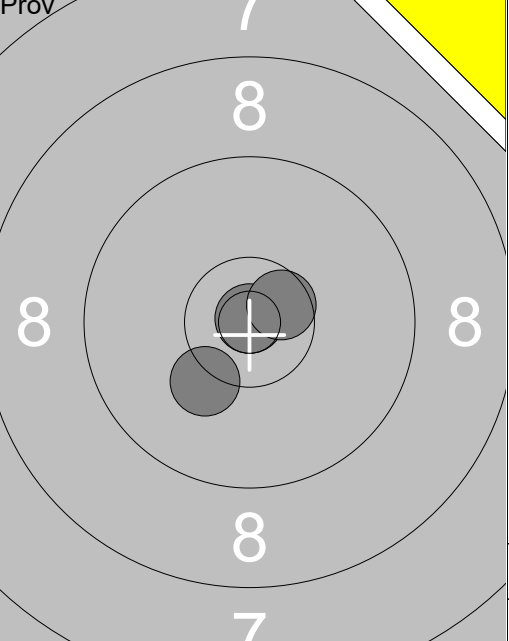
Prov 	<p>1: 9.6 ↑</p> <p>2: 10.5 ↗</p> <p>3: 10.2 ↗</p> <p>4: 9.4 ↗</p> <p>5: 9.1 ←</p> <p>6: 8.9 ↑</p> <p>7: 9.8 →</p> <p>8: 10.2 ↓</p> <p>9: 9.8 ↗</p> <p>10: 9.6 ←</p>	Prov 	<p>11: 10.2 ↘</p> <p>12: 10.9x ↑</p> <p>13: 10.6x ↗</p>
Serie 92.0		Serie 30.0	
Total 179.0		Total 179.0	

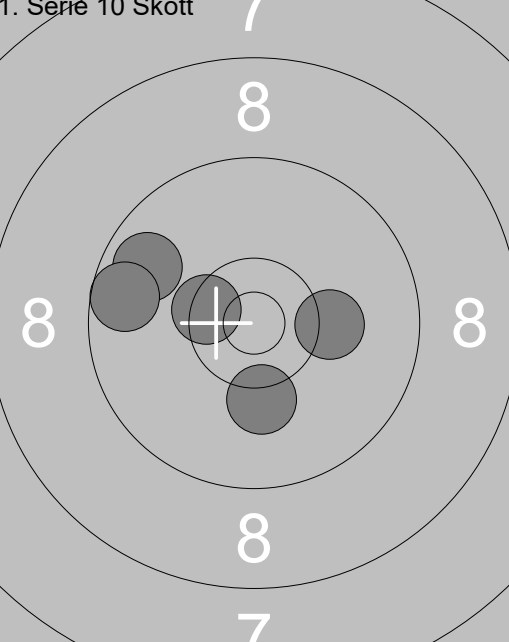
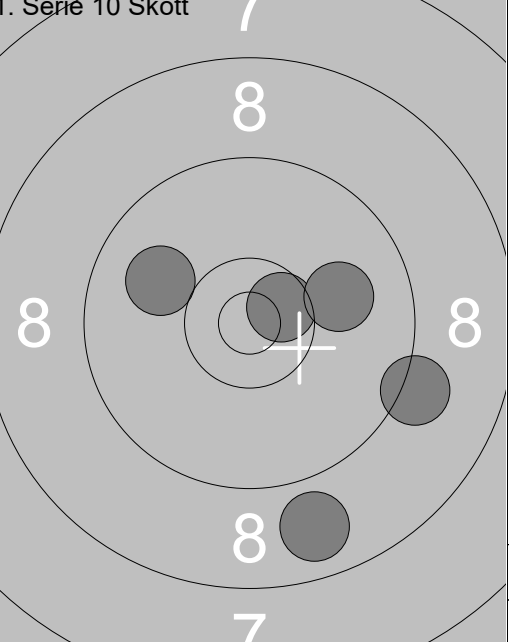
1. Serie 10 Skott 	<p>1: 10.2 ↓</p> <p>2: 10.2 →</p> <p>3: 9.7 ↖</p> <p>4: 10.5x ↖</p> <p>5: 9.6 ←</p>	1. Serie 10 Skott 	<p>6: 9.2 →</p> <p>7: 8.8 ↓</p> <p>8: 10.6x ↗</p> <p>9: 10.0 ↖</p> <p>10: 10.0 →</p>
Serie 48.0		Serie 47.0	
Total 227.0		Total 274.0	

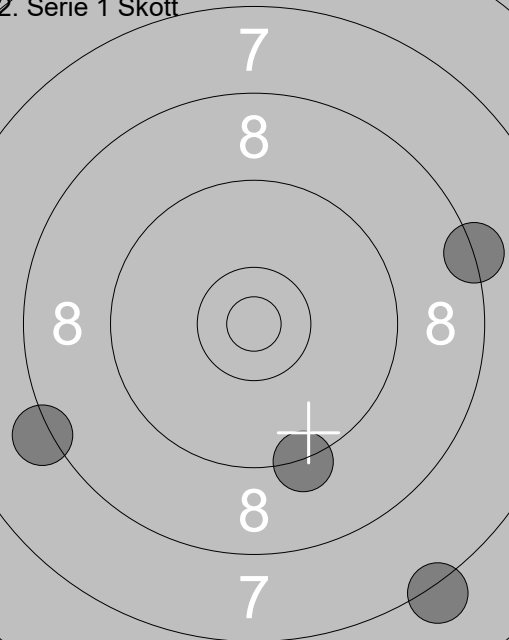
2. Serie 1 Skott 	<p>1: 8.3 →</p> <p>2: 9.3 ↓</p> <p>3: 8.2 ←</p> <p>4: 0.0</p> <p>5: 7.2 ↓</p>		
Serie 32.0			
Total 306.0			

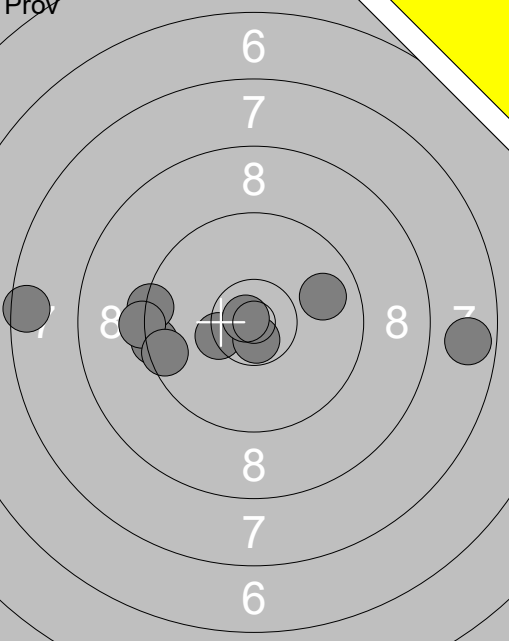
	<p>1: 10.4✕</p> <p>2: 9.4 ←</p> <p>3: 7.5 ←</p> <p>4: 9.4 ←</p> <p>5: 9.3 ←</p> <p>6: 7.7 →</p> <p>7: 10.7✕↓</p> <p>8: 9.8 →</p> <p>9: 9.5 ←</p> <p>10: 10.8✕</p>	<p>11: 9.7 ↖</p>
Serie 89.0		Serie 9.0
Total 178.0		Total 178.0

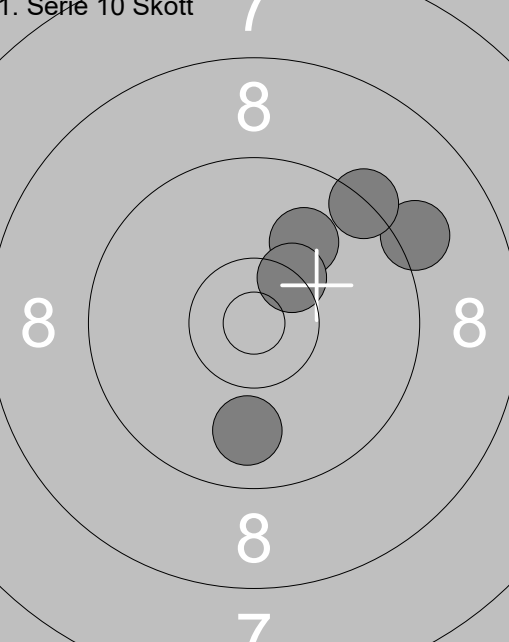
<p>1. Serie 10 Skott</p> 	<p>1: 10.0 ↗</p> <p>2: 10.4✕↗</p> <p>3: 9.9 ↓</p> <p>4: 9.1 ↗</p> <p>5: 9.3 ↗</p>	<p>6: 9.4 ↗</p> <p>7: 7.5 ↘</p> <p>8: 8.5 ↘</p> <p>9: 10.6✕↘</p> <p>10: 8.5 ←</p>
Serie 47.0		Serie 42.0
Total 225.0		Total 267.0

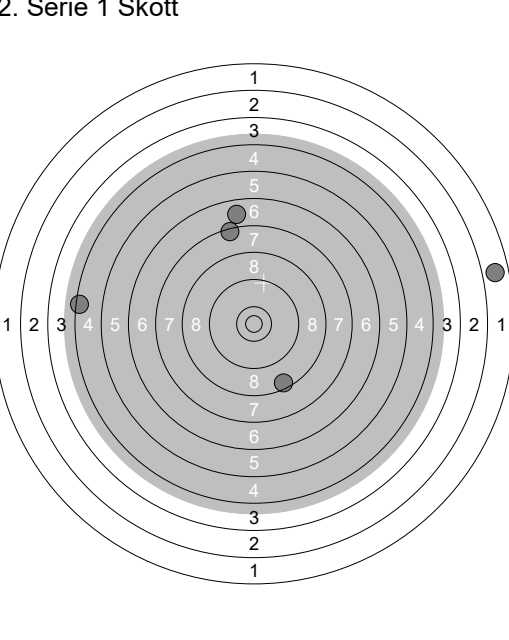
<p>2. Serie 1 Skott</p> 	<p>1: 4.4 ←</p> <p>2: 8.5 ↘</p> <p>3: 6.8 ↑</p> <p>4: 7.4 ↑</p> <p>5: 1.8 →</p>	
Serie 26.0		
Total 293.0		

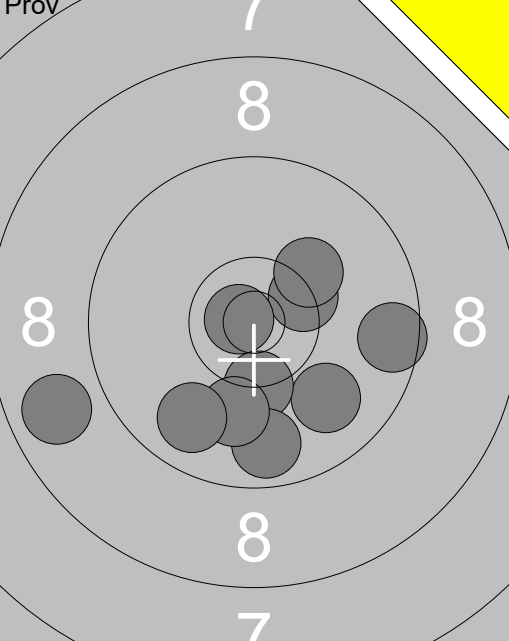
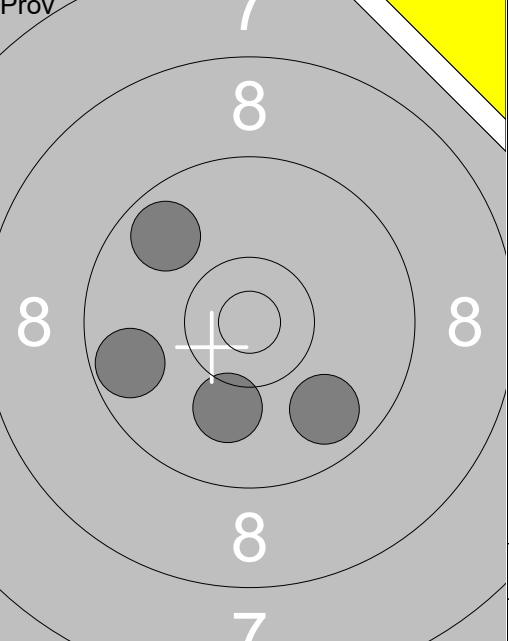
 <p>Prov</p>	<p>1: 9.9 ↘ 2: 10.3x↓ 3: 8.8 ← 4: 9.7 ↓ 5: 10.0 ↓ 6: 10.4x↗ 7: 9.6 → 8: 10.2 ↗ 9: 10.8x↖ 10: 9.8 ↓</p>	 <p>Prov</p>	<p>11: 9.7 ← 12: 10.1 ↓ 13: 9.8 ↓ 14: 9.7 ↗</p>
Serie 94.0		Serie 37.0	
Total 178.0		Total 178.0	

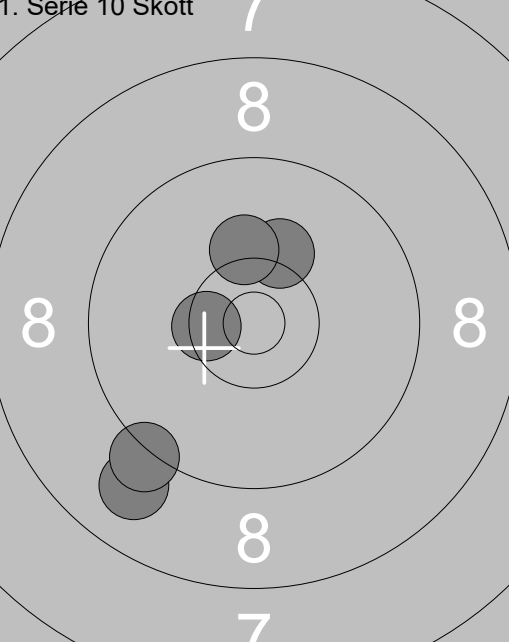
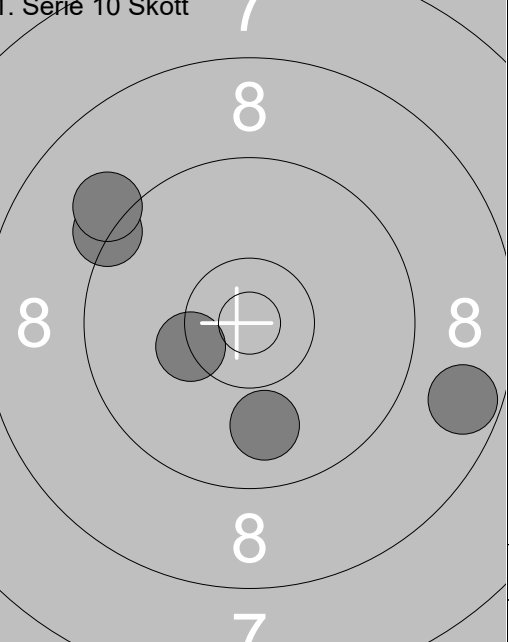
<p>1. Serie 10 Skott</p> 	<p>1: 8.9 ↘ 2: 9.2 ↘ 3: 10.2 ↑ 4: 10.2 ↑ 5: 10.5x↖</p>	<p>1. Serie 10 Skott</p> 	<p>6: 8.7 → 7: 10.3x↖ 8: 9.3 ↗ 9: 9.9 ↓ 10: 9.1 ↗</p>
Serie 47.0		Serie 45.0	
Total 225.0		Total 270.0	

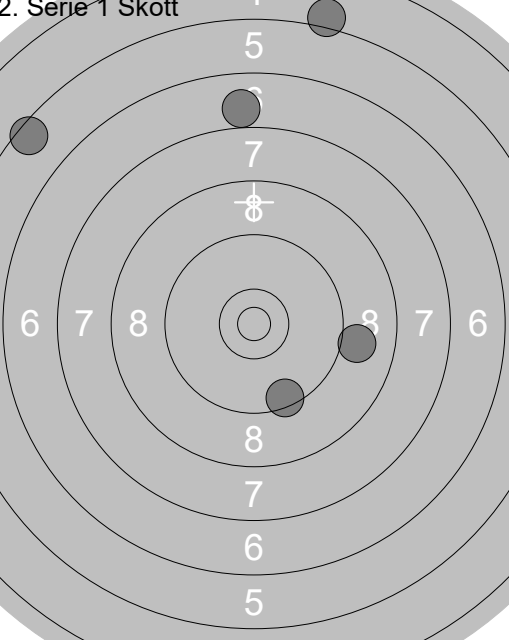
<p>2. Serie 1 Skott</p> 	<p>1: 5.5 ↖ 2: 5.1 ↑ 3: 6.9 ↑ 4: 9.0 → 5: 9.5 ↓</p>		
Serie 34.0			
Total 304.0			

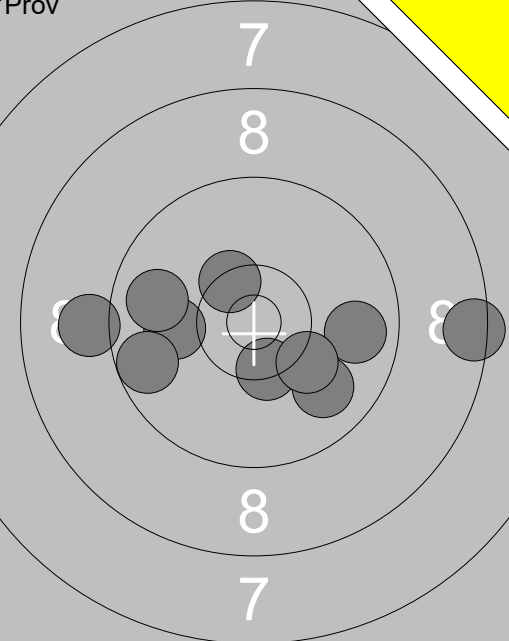
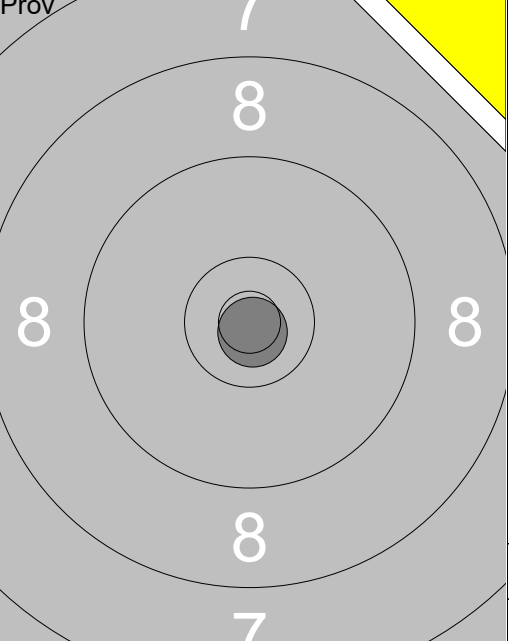
Prov 	1: 10.0 ← 2: 9.8 ← 3: 8.5 → 4: 10.4x ↗ 5: 9.9 ↘ 6: 9.8 → 7: 10.4x ↘ 8: 9.7 ← 9: 9.1 ← 10: 10.2 ↘ <hr/> Serie 93.0 Total 178.0	Prov 	11: 10.9x ↘ <hr/> Serie 10.0 Total 178.0
--	--	--	--

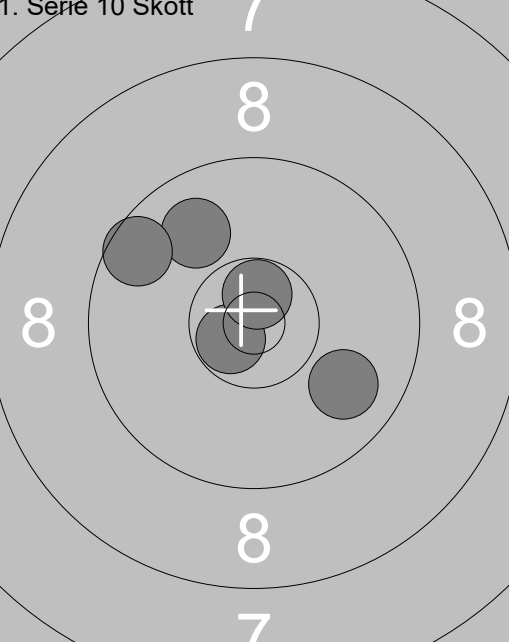
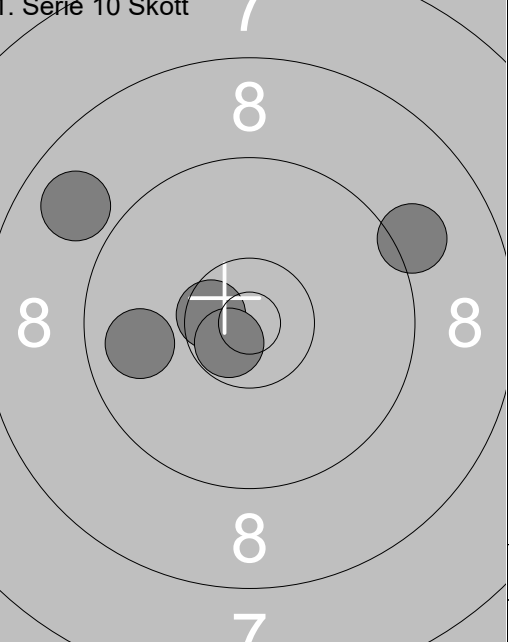
1. Serie 10 Skott 	1: 10.7x ↘ 2: 10.7x ↗ 3: 9.9 ↗ 4: 9.6 ↗ 5: 9.9 ↘ <hr/> Serie 47.0 Total 225.0	1. Serie 10 Skott 	6: 9.1 ↗ 7: 8.9 ↖ 8: 9.8 ← 9: 10.6x ↖ 10: 10.7x ↘ <hr/> Serie 46.0 Total 271.0
--	---	--	--

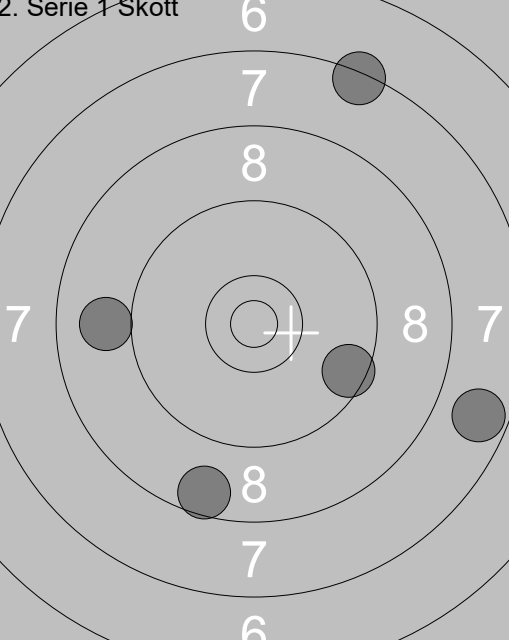
2. Serie 1 Skott 	1: 7.4 ↗ 2: 9.5 → 3: 9.0 ← 4: 8.6 ↘ 5: 7.7 → <hr/> Serie 40.0 Total 311.0		
--	---	--	--