

<p>Prov</p>	<p>1: 10.0 ↓ 2: 9.7 ↓ 3: 9.4 ↓ 4: 10.8x → 5: 9.8 → 6: 8.3 ↓ 7: 7.6 ↓ 8: 8.6 ↗ 9: 8.6 ↘ 10: 8.9 ↘</p> <p>Serie 86.0 Total 183.0</p>	<p>Prov</p>	<p>11: 6.9 ↘ 12: 8.7 ↓ 13: 9.5 ← 14: 9.4 ↗ 15: 9.9 ←</p> <p>Serie 41.0 Total 183.0</p>
-------------	--	-------------	---

<p>1. Serie 10 Skott</p>	<p>1: 9.7 ← 2: 10.0 ↓ 3: 10.4x ↘ 4: 8.9 ← 5: 10.7x ↓</p> <p>Serie 47.0 Total 230.0</p>	<p>1. Serie 10 Skott</p>	<p>6: 8.7 ← 7: 9.0 ← 8: 9.5 ↑ 9: 10.2 ↓ 10: 8.7 ↓</p> <p>Serie 44.0 Total 274.0</p>
--------------------------	---	--------------------------	--

<p>2. Serie 1 Skott</p>	<p>1: 8.9 ↓ 2: 10.0 ↓ 3: 8.7 ↓ 4: 8.7 ← 5: 9.1 ↗</p> <p>Serie 43.0 Total 317.0</p>		
-------------------------	---	--	--

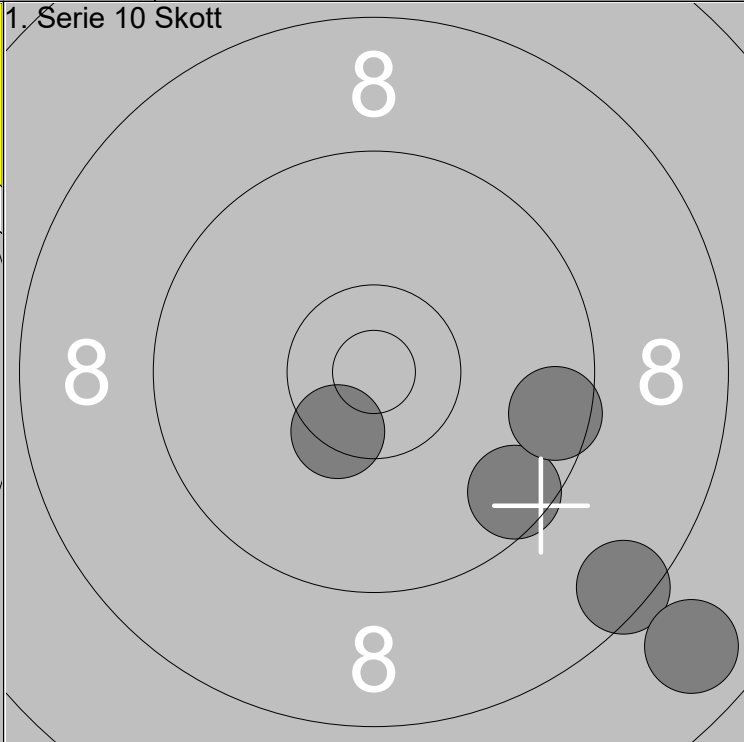
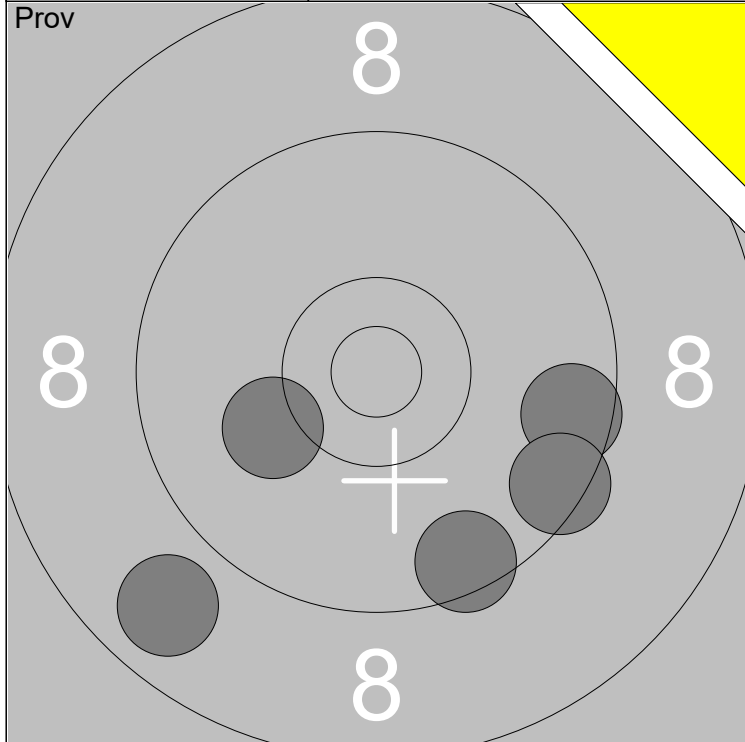

1: 8.8 ↙
2: 9.6 →
3: 9.5 ↘
4: 9.5 ↘
5: 10.1 ↙

Serie	45
Total	175

1: 8.5 ↘
2: 9.6 ↘
3: 9.6 →
4: 7.8 ↘
5: 10.4x ↙

Serie	43
Total	218

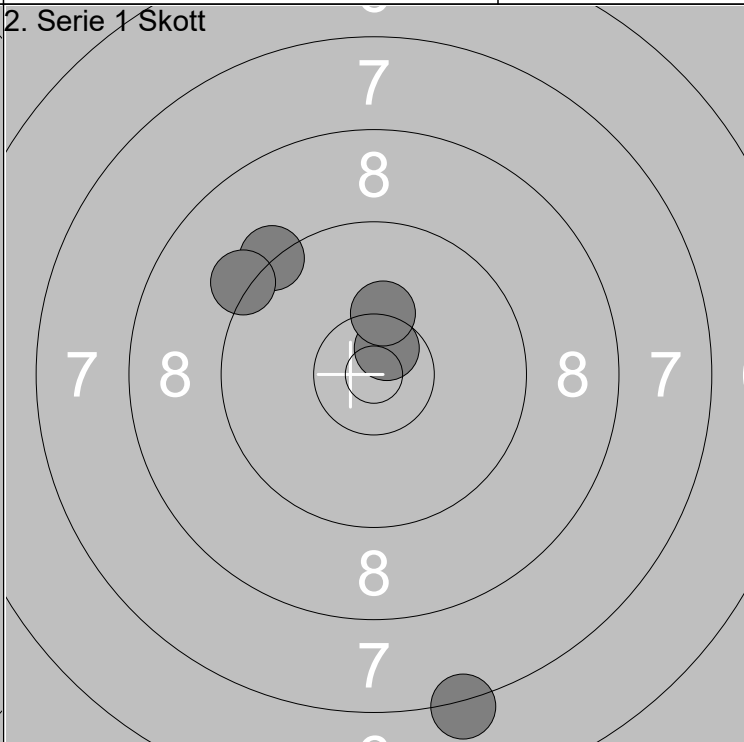
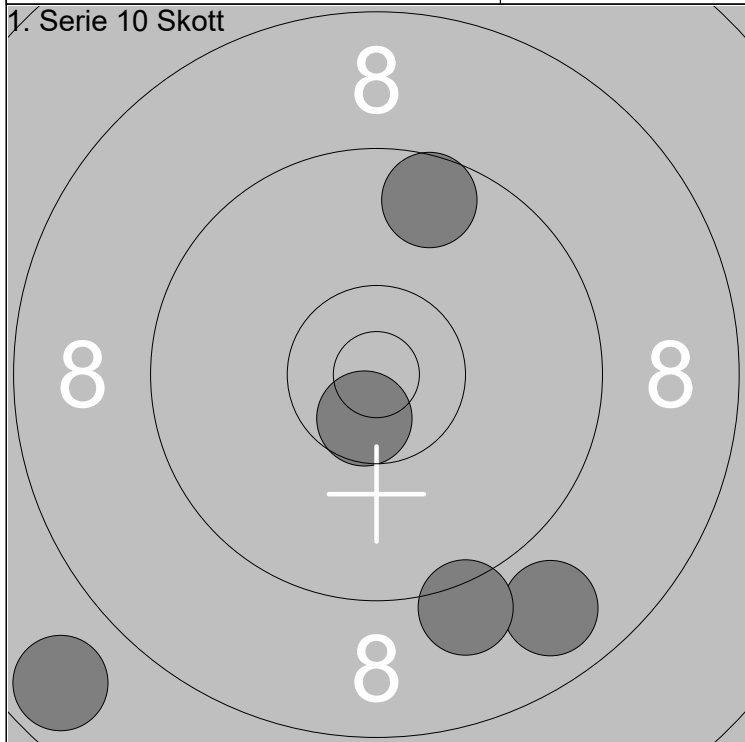

6: 8.8 ↘
7: 7.7 ↙
8: 9.6 ↑
9: 9.1 ↘
10: 10.6x ↙

Serie	43
Total	261

1: 7.2 ↘
2: 10.6x ↗
3: 9.3 ↖
4: 9.2 ↖
5: 10.3 ↑

Serie	45
Total	306

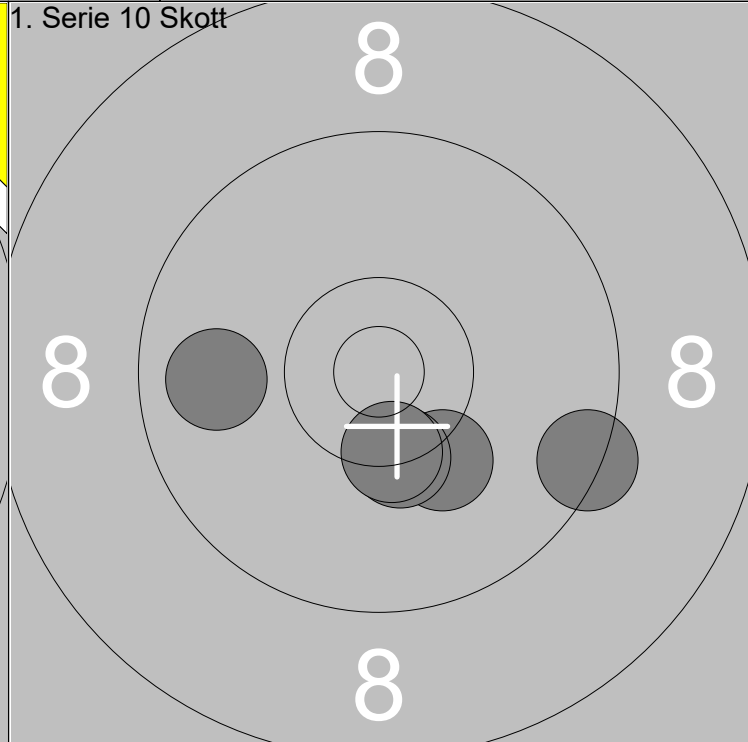
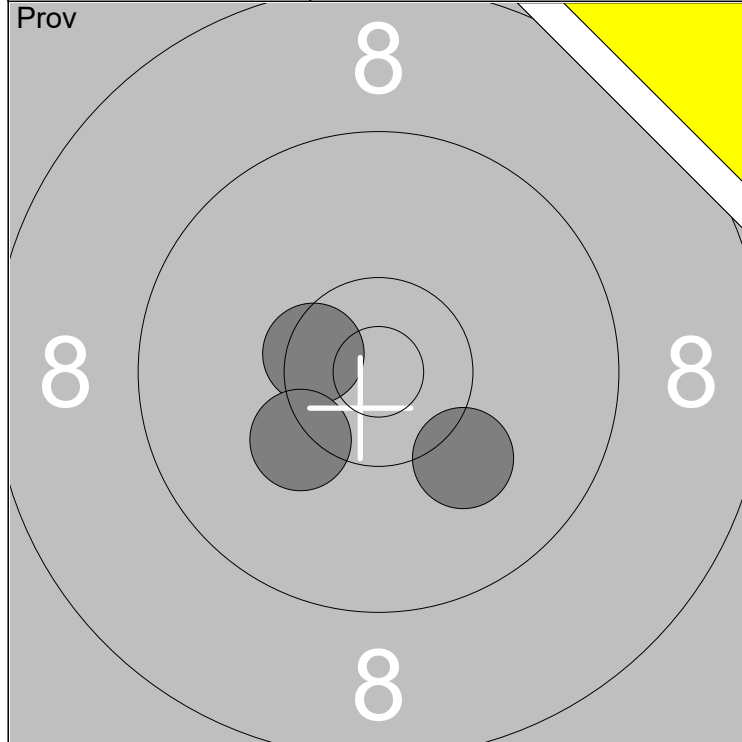

1: 10.5x	←
2: 10.2	↘
3: 10.1	↘

Serie	30
Total	189

1: 10.2	↘
2: 10.3x	↘
3: 10.4x	↘
4: 9.4	↘
5: 9.8	←

Serie	48
Total	237

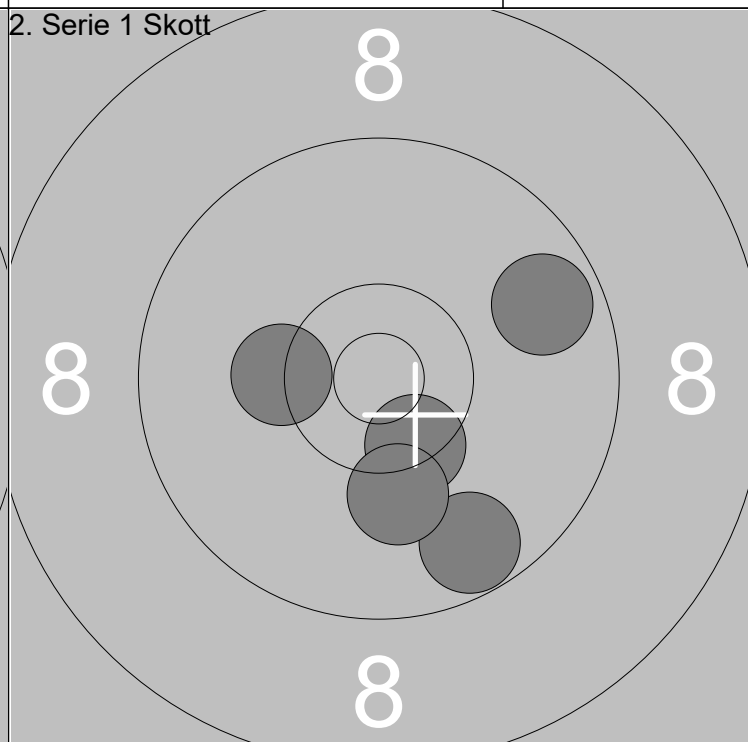
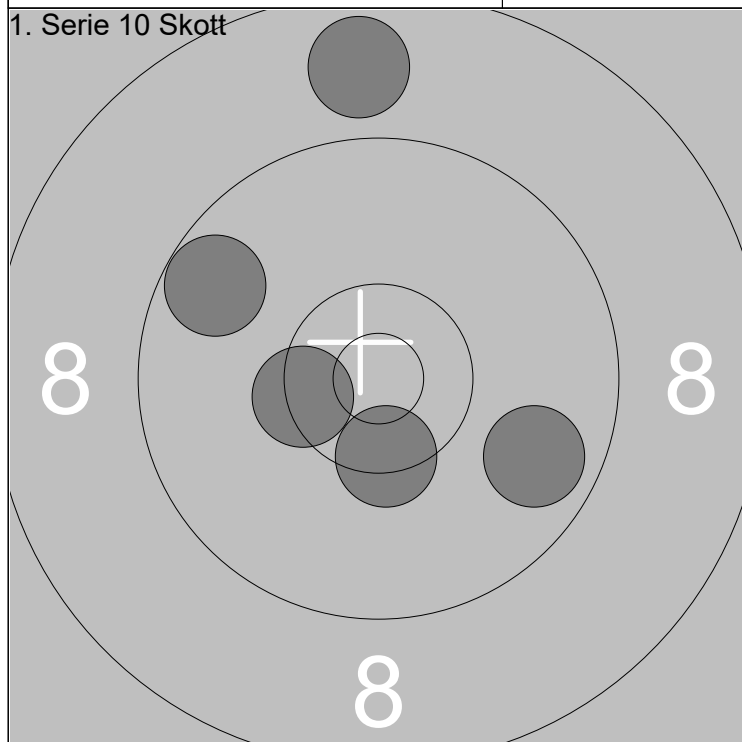

6: 9.7	↖
7: 9.8	↘
8: 10.4x	←
9: 8.8	↑
10: 10.4x	↓

Serie	46
Total	283

1: 10.3	←
2: 9.7	↗
3: 9.7	↘
4: 10.4x	↘
5: 10.1	↓

Serie	48
Total	331

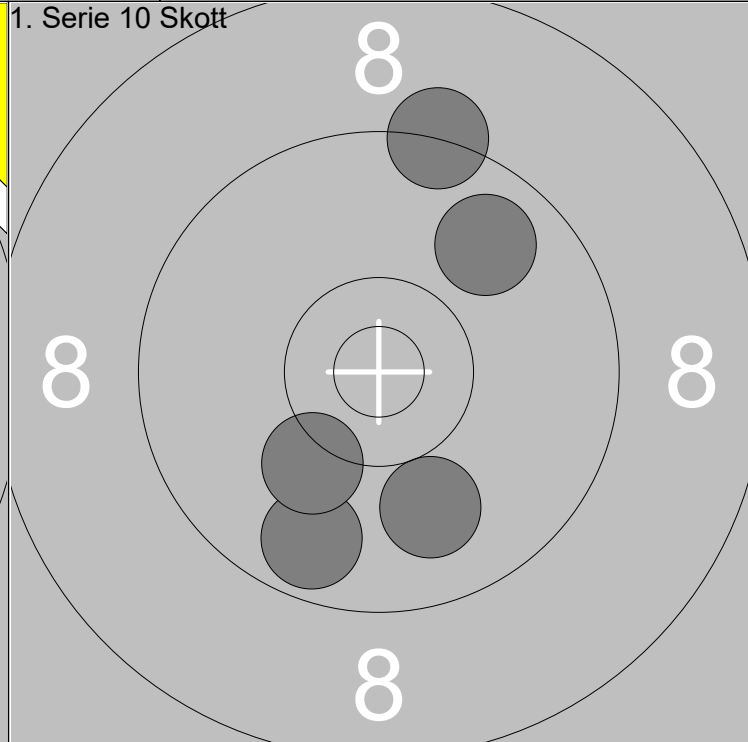
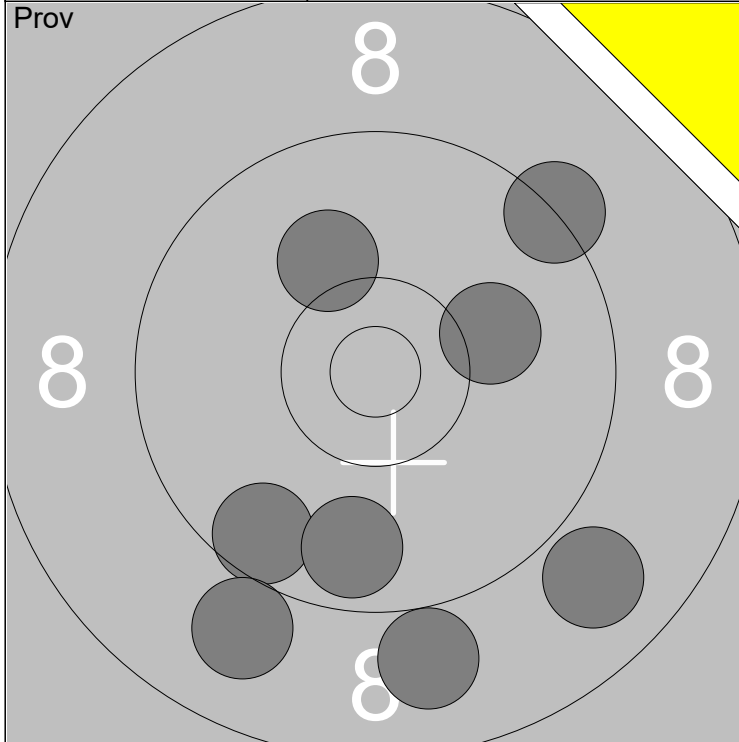

1: 10.1 ↖	6: 9.7 ↓	Serie 73	
2: 9.3 ↗	7: 9.0 ↓		
3: 10.1 →	8: 9.0 ↓	Total 189	
4: 8.9 ↘			
5: 9.6 ↙			

1: 9.7 ↓	Serie 47
2: 9.3 ↗	
3: 9.8 ↗	Total 236
4: 10.2 ↘	
5: 10.0 ↙	

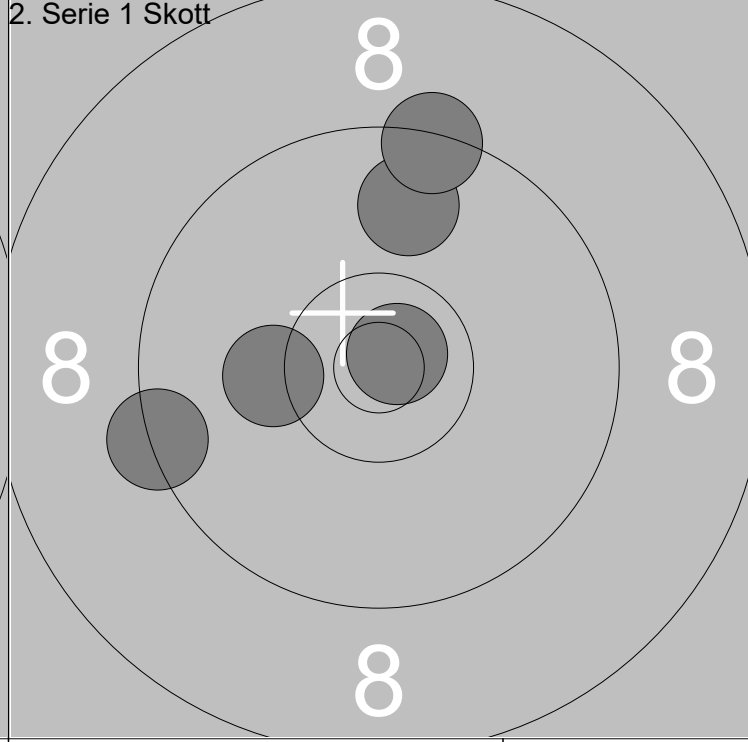
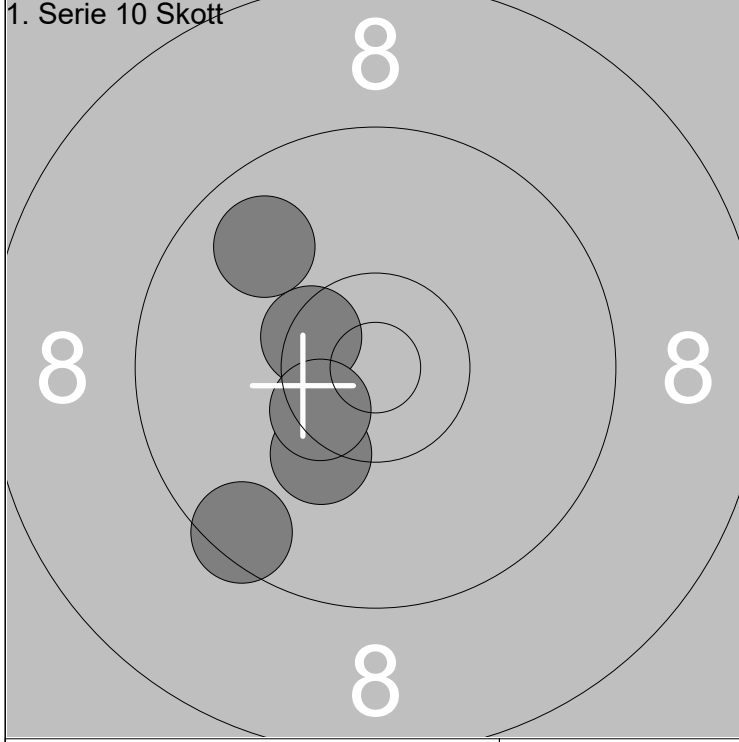

6: 9.8 ↖	Serie 48
7: 10.5x ↖	
8: 10.2 ↓	Total 284
9: 9.5 ↓	
10: 10.5x ↙	

1: 10.8x ↗	Serie 47
2: 9.8 ↗	
3: 10.2 ←	Total 331
4: 9.4 ↗	
5: 9.4 ←	

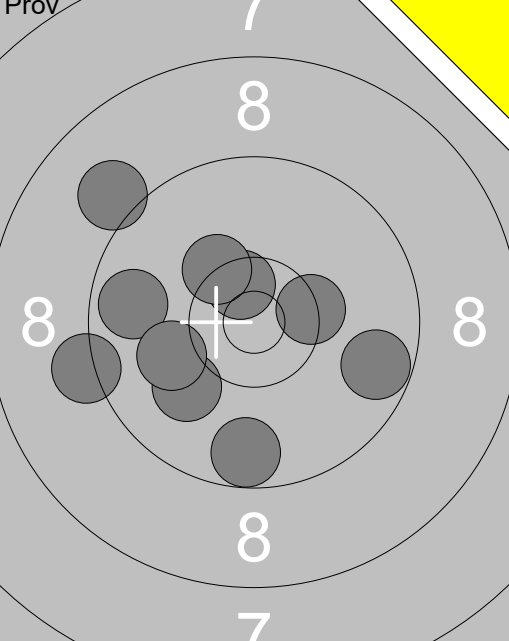
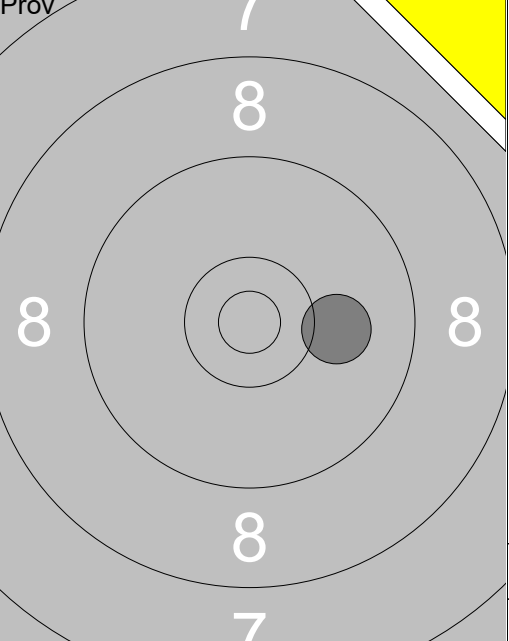
Prov 	1: 10.5x ↗ 2: 10.3x ↘ 3: 10.4x → 4: 9.7 ← 5: 10.0 ↙ 6: 10.1 ← 7: 9.7 → 8: 9.6 ↓ 9: 9.2 ← 10: 9.1 ↖ <hr/> Serie 95.0 <hr/> Total 189.0	Prov 	11: 10.1 → <hr/> Serie 10.0 <hr/> Total 189.0
--	--	--	---

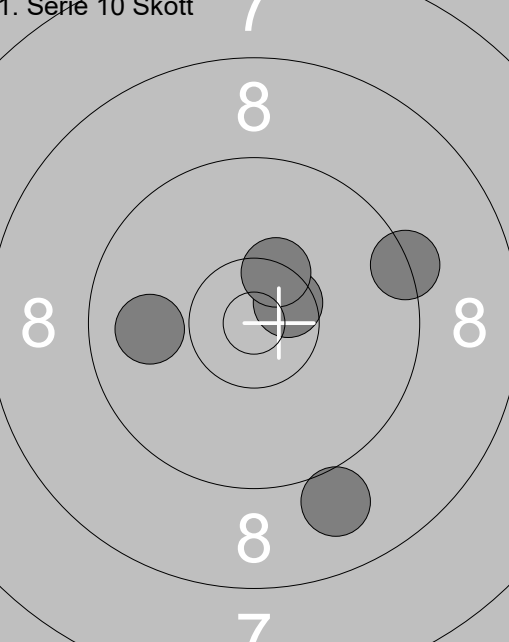
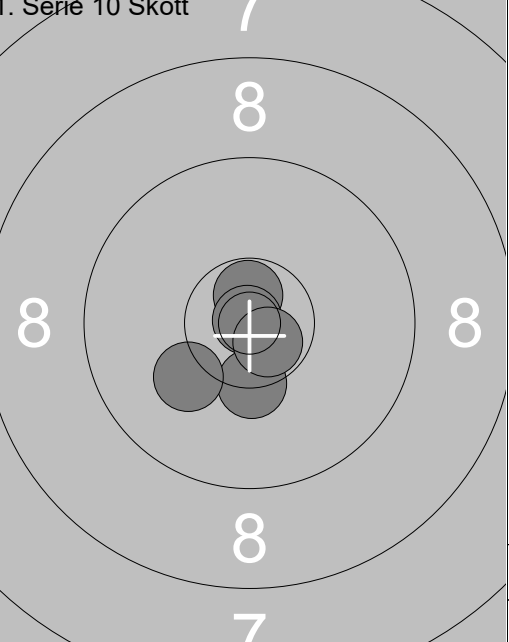
1. Serie 10 Skott 	1: 10.6x ↗ 2: 9.3 → 3: 9.0 ↓ 4: 10.4x ↗ 5: 9.9 ← <hr/> Serie 47.0 <hr/> Total 236.0	1. Serie 10 Skott 	6: 10.7x ↗ 7: 10.3x ↘ 8: 10.1 ↙ 9: 10.9x ↘ 10: 10.7x ↘ <hr/> Serie 50.0 <hr/> Total 286.0
--	---	--	---

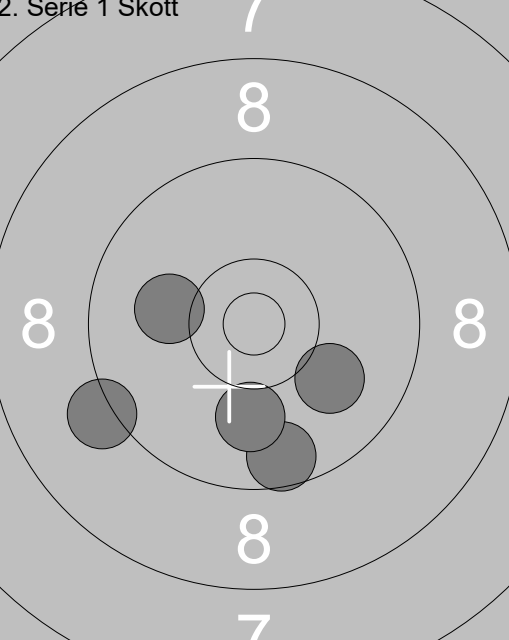
2. Serie 1 Skott 	1: 9.6 ↓ 2: 10.0 ↘ 3: 9.2 ↙ 4: 10.0 ↓ 5: 10.1 ← <hr/> Serie 48.0 <hr/> Total 334.0		
--	--	--	--

	<p>1: 7.0 ↗</p> <p>2: 8.8 ↗</p> <p>3: 9.7 ↑</p> <p>4: 10.3x↑</p> <p>5: 8.9 ↑</p> <p>6: 10.5x➤</p> <p>7: 10.1 ↑</p> <p>8: 9.4 ➡</p> <p>9: 10.1 ↗</p> <p>10: 9.4 ↓</p>		<p>11: 10.8x↖</p> <p>12: 9.4 ↓</p>
Serie 90.0		Serie 19.0	
Total 188.0		Total 188.0	

<p>1. Serie 10 Skott</p>	<p>1: 10.3x↖</p> <p>2: 9.4 ↖</p> <p>3: 10.7x↖</p> <p>4: 10.1 ↙</p> <p>5: 10.8x↖</p>		<p>6: 10.5x↘</p> <p>7: 10.0 ↓</p> <p>8: 8.9 ↓</p> <p>9: 10.2 ➡</p> <p>10: 10.3x↖</p>
Serie 49.0		Serie 48.0	
Total 237.0		Total 285.0	

<p>2. Serie 1 Skott</p>	<p>1: 9.5 ↖</p> <p>2: 8.5 ↓</p> <p>3: 9.9 ➡</p> <p>4: 9.0 ➡</p> <p>5: 8.7 ↙</p>		
Serie 43.0			
Total 328.0			

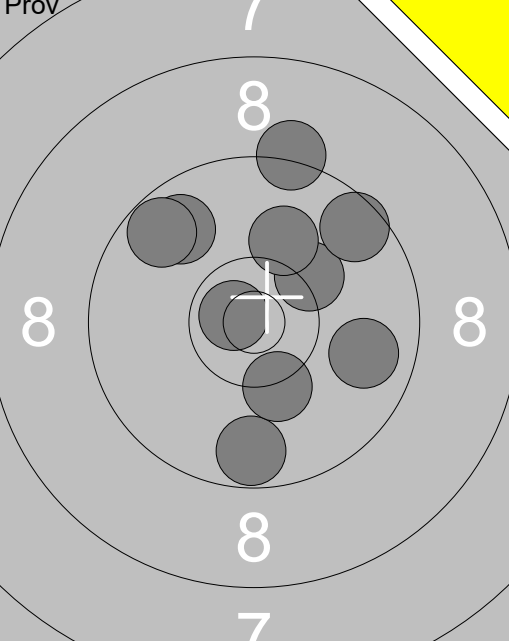
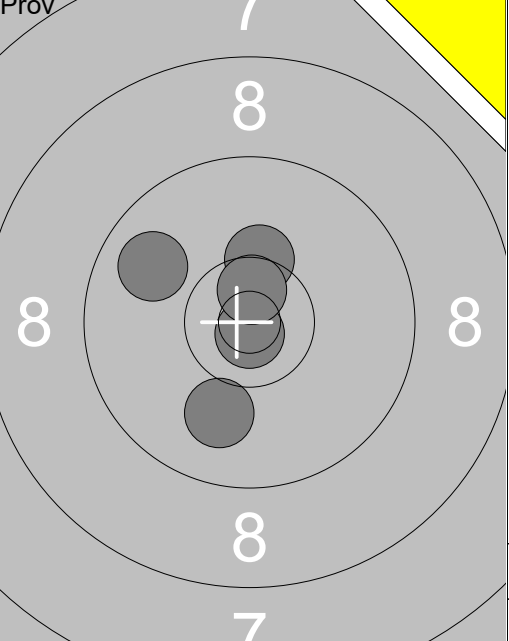
 <p style="text-align: center;">7</p>	<p>1: 10.2 ↗</p> <p>2: 9.8 ↖</p> <p>3: 9.7 ↓</p> <p>4: 9.2 ↑</p> <p>5: 10.3 ↓</p> <p>6: 10.7 ↖</p> <p>7: 9.7 ↖</p> <p>8: 9.8 →</p> <p>9: 9.6 ↗</p> <p>10: 10.1 ↑</p>	 <p style="text-align: center;">7</p>	<p>11: 10.3x ↗</p> <p>12: 10.8x ↓</p> <p>13: 10.0 ↓</p> <p>14: 9.8 ↖</p> <p>15: 10.6x ↗</p>
	Serie 94.0		Serie 49.0
	Total 187.0		Total 187.0

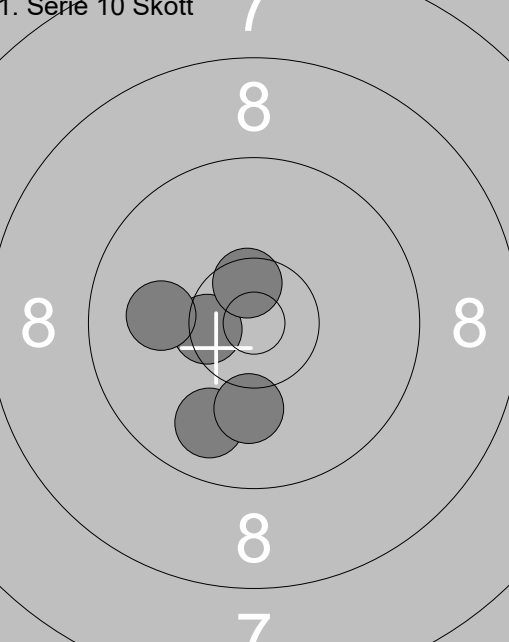
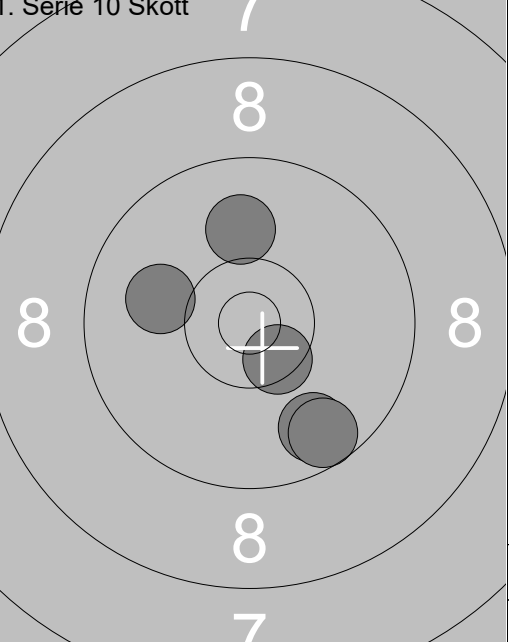
<p>1. Serie 10 Skott</p>  <p style="text-align: center;">7</p>	<p>1: 10.5x ↖</p> <p>2: 9.9 ↓</p> <p>3: 10.5x ↗</p> <p>4: 10.0 ←</p> <p>5: 10.1 ↓</p>	<p>1. Serie 10 Skott</p>  <p style="text-align: center;">7</p>	<p>6: 9.7 ↓</p> <p>7: 10.0 ↑</p> <p>8: 9.6 ↓</p> <p>9: 10.0 ←</p> <p>10: 10.5x ↘</p>
	Serie 49.0		Serie 48.0
	Total 236.0		Total 284.0

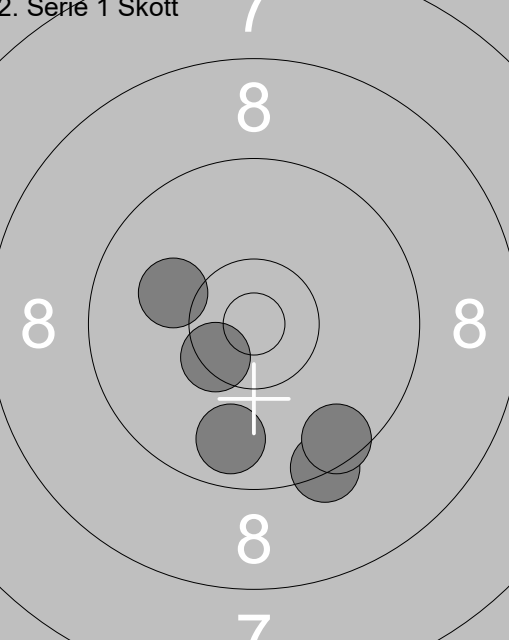
<p>2. Serie 1 Skott</p>  <p style="text-align: center;">7</p>	<p>1: 9.4 ↓</p> <p>2: 9.5 ↓</p> <p>3: 10.1 ↖</p> <p>4: 9.8 ↓</p> <p>5: 10.4x ↖</p>		
	Serie 47.0		
	Total 331.0		

	<p>1: 8.5 ↘</p> <p>2: 10.6x↗</p> <p>3: 8.4 ↖</p> <p>4: 9.1 ↘</p> <p>5: 10.4x→</p> <p>6: 8.0 →</p> <p>7: 9.5 →</p> <p>8: 9.9 ↑</p> <p>9: 10.1 ↘</p> <p>10: 10.0 ↗</p>	<p>11: 9.7 ↘</p> <p>12: 9.2 ↖</p> <p>13: 9.7 ↖</p> <p>14: 9.7 ↑</p>
Serie 91.0		Serie 36.0
Total 181.0		Total 181.0

<p>1. Serie 10 Skott</p> 	<p>1: 8.2 →</p> <p>2: 10.4x↘</p> <p>3: 10.3x↑</p> <p>4: 10.2 →</p> <p>5: 10.3x→</p>	<p>6: 9.9 →</p> <p>7: 9.9 ↘</p> <p>8: 9.7 ↖</p> <p>9: 8.1 ↘</p> <p>10: 10.1 ↖</p>
Serie 48.0		Serie 45.0
Total 229.0		Total 274.0

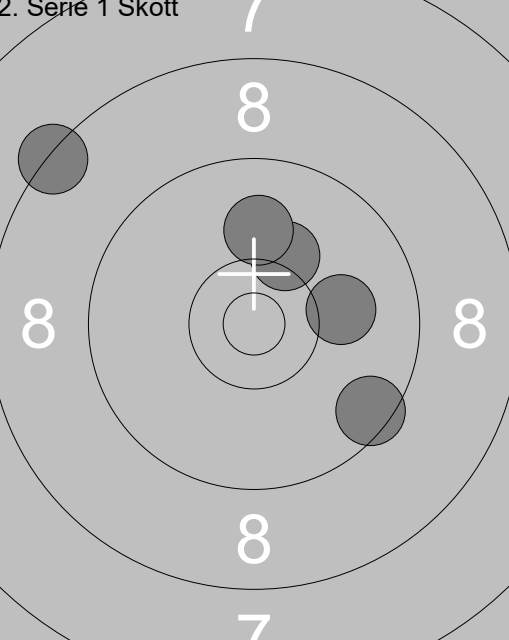
<p>2. Serie 1 Skott</p> 	<p>1: 10.1 →</p> <p>2: 8.4 ↖</p> <p>3: 10.2 ↑</p> <p>4: 9.5 ↘</p> <p>5: 10.0 ↑</p>	
Serie 47.0		
Total 321.0		

	<p>1: 9.8 ←</p> <p>2: 9.4 ←</p> <p>3: 9.9 ↑</p> <p>4: 10.3 ↓</p> <p>5: 9.5 ↑</p> <p>6: 10.7x ↗</p> <p>7: 9.5 ←</p> <p>8: 8.9 ↑</p> <p>9: 8.1 ↖</p> <p>10: 8.9 ↓</p>	
Serie 89.0		Serie 10.0
Total 172.0		Total 172.0

<p>1. Serie 10 Skott</p>	<p>1: 9.1 →</p> <p>2: 9.5 ↓</p> <p>3: 10.1 →</p> <p>4: 9.6 ↑</p> <p>5: 10.2 ←</p>	<p>1. Serie 10 Skott</p>
Serie 47.0		Serie 46.0
Total 219.0		Total 265.0

<p>2. Serie 1 Skott</p>	<p>1: 8.5 ↖</p> <p>2: 5.4 ↓</p> <p>3: 9.0 →</p> <p>4: 8.6 ↗</p> <p>5: 7.8 →</p>	
Serie 37.0		
Total 302.0		

	<p>Prov</p> <p>1: 9.4 →</p> <p>2: 10.1 →</p> <p>3: 9.8 ↓</p> <p>4: 10.8x ↘</p> <p>5: 9.7 ↓</p> <p>6: 10.5x ↘</p> <p>7: 10.0 ↓</p> <p>8: 9.3 →</p> <p>9: 10.7x ↗</p> <p>10: 9.7 ↓</p>		<p>Prov</p> <p>11: 10.2 ↑</p> <p>12: 10.1 ↓</p> <p>13: 10.6x ↗</p> <p>14: 10.4x ↗</p> <p>15: 9.5 ↓</p>
Serie 95.0		Serie 49.0	
Total 192.0		Total 192.0	

<p>1. Serie 10 Skott</p>	<p>1: 10.4x ↘</p> <p>2: 10.0 ↖</p> <p>3: 10.2 ↑</p> <p>4: 10.1 ↘</p> <p>5: 10.3x ↘</p>	<p>1. Serie 10 Skott</p>	<p>6: 10.5x ↘</p> <p>7: 9.4 →</p> <p>8: 10.0 ↓</p> <p>9: 10.5x →</p> <p>10: 10.4x ↗</p>
Serie 50.0		Serie 49.0	
Total 242.0		Total 291.0	

<p>2. Serie 1 Skott</p>	<p>1: 10.6x ↘</p> <p>2: 9.9 ↖</p> <p>3: 10.7x ↘</p> <p>4: 10.5x →</p> <p>5: 10.8x ↗</p>		
Serie 49.0			
Total 340.0			

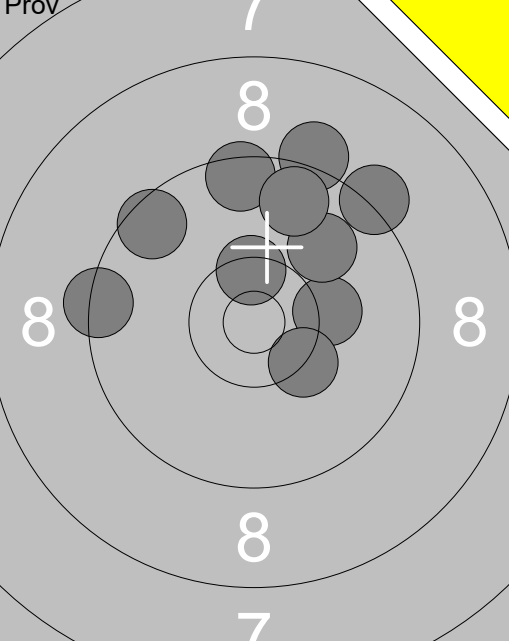
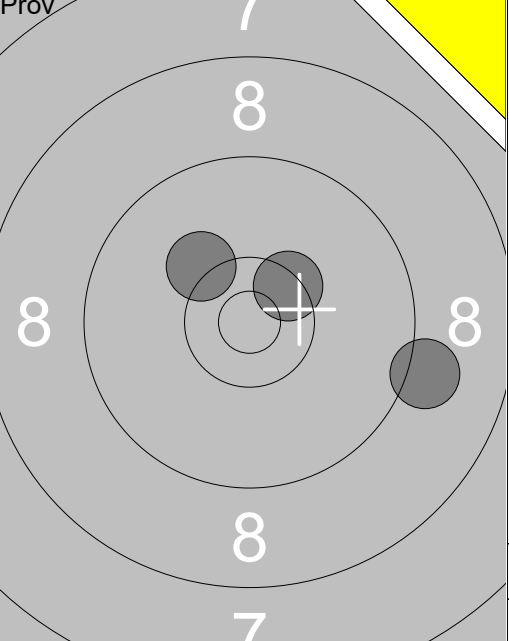
 <p style="text-align:center;">7 8 8 8 7</p>	<p>1: 9.5 ↖</p> <p>2: 10.2 →</p> <p>3: 9.4 ←</p> <p>4: 9.2 ↑</p> <p>5: 9.2 ↗</p> <p>6: 10.4x↑</p> <p>7: 9.9 ↗</p> <p>8: 9.5 ↑</p> <p>9: 10.3x↘</p> <p>10: 9.7 ↑</p>	 <p style="text-align:center;">7 8 8 8 7</p>	<p>11: 9.1 →</p> <p>12: 10.4x↗</p> <p>13: 10.2 ↖</p>
Serie 93.0		Serie 29.0	
Total 192.0		Total 192.0	

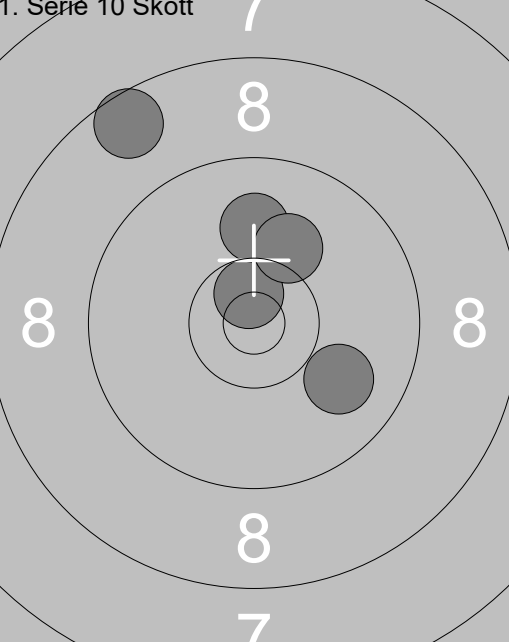
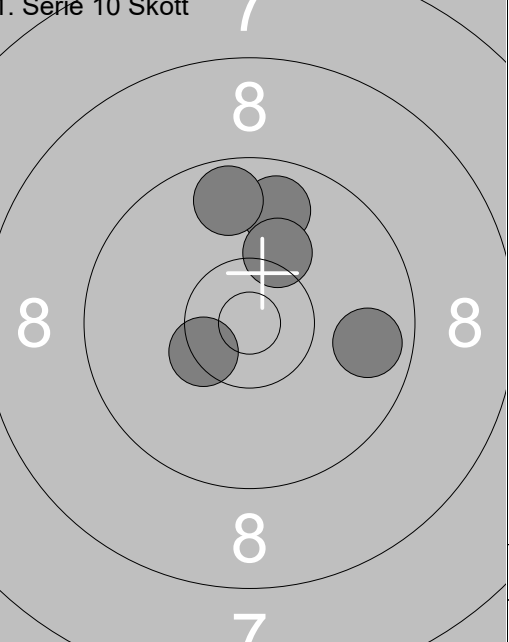
<p>1. Serie 10 Skott</p>  <p style="text-align:center;">7 8 8 8 7</p>	<p>1: 8.6 ↖</p> <p>2: 10.7x↑</p> <p>3: 10.0 ↑</p> <p>4: 9.9 →</p> <p>5: 10.1 ↑</p>	<p>1. Serie 10 Skott</p>  <p style="text-align:center;">7 8 8 8 7</p>	<p>6: 10.4x↘</p> <p>7: 9.8 ↑</p> <p>8: 9.7 ↑</p> <p>9: 9.8 →</p> <p>10: 10.2 ↑</p>
Serie 47.0		Serie 47.0	
Total 239.0		Total 286.0	

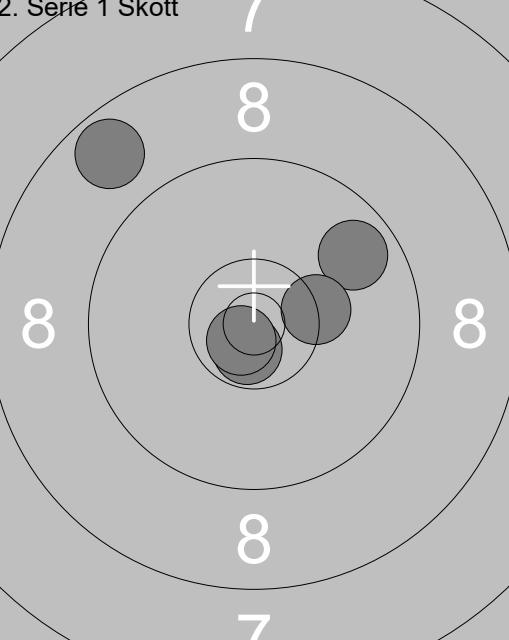
<p>2. Serie 1 Skott</p>  <p style="text-align:center;">7 8 8 7</p>	<p>1: 9.7 ↗</p> <p>2: 10.7x↘</p> <p>3: 8.7 ↖</p> <p>4: 10.7x↘</p> <p>5: 10.3x→</p>		
Serie 47.0			
Total 333.0			

	<p>1: 9.5 ↓</p> <p>2: 10.4x↓</p> <p>3: 10.4x↗</p> <p>4: 9.7 →</p> <p>5: 10.4x↖</p> <p>6: 9.8 ↗</p> <p>7: 10.4x↘</p> <p>8: 9.4 ↗</p> <p>9: 10.1↖</p> <p>10: 9.6 ↖</p>		<p>11: 9.9 ↗</p> <p>12: 10.3↖</p> <p>13: 10.2↖</p>
Serie 95.0		Serie 29.0	
Total 189.0		Total 189.0	

<p>1. Serie 10 Skott</p>	<p>1: 9.6 →</p> <p>2: 10.5x↓</p> <p>3: 10.0 ↖</p> <p>4: 9.0 ↗</p> <p>5: 10.3→</p>		<p>6: 10.7x↗</p> <p>7: 10.8x↖</p> <p>8: 10.2→</p> <p>9: 8.6 ↖</p> <p>10: 10.1 ↗</p>
Serie 48.0		Serie 48.0	
Total 237.0		Total 285.0	

<p>2. Serie 1 Skott</p>	<p>1: 9.2 →</p> <p>2: 10.7x↖</p> <p>3: 10.6x→</p> <p>4: 10.0 ↖</p> <p>5: 10.7x↗</p>		
Serie 49.0			
Total 334.0			

	<p>1: 9.9 ←</p> <p>2: 9.1 ↓</p> <p>3: 10.1 ↑</p> <p>4: 9.4 →</p> <p>5: 9.9 →</p> <p>6: 9.9 ↑</p> <p>7: 10.6x ↓</p> <p>8: 10.3x ↘</p> <p>9: 10.6x →</p> <p>10: 10.8x ↓</p>	<p>11: 10.5x ↘</p> <p>12: 10.5x ↗</p> <p>13: 9.2 ←</p>
Serie 95.0		Serie 29.0
Total 185.0		Total 185.0

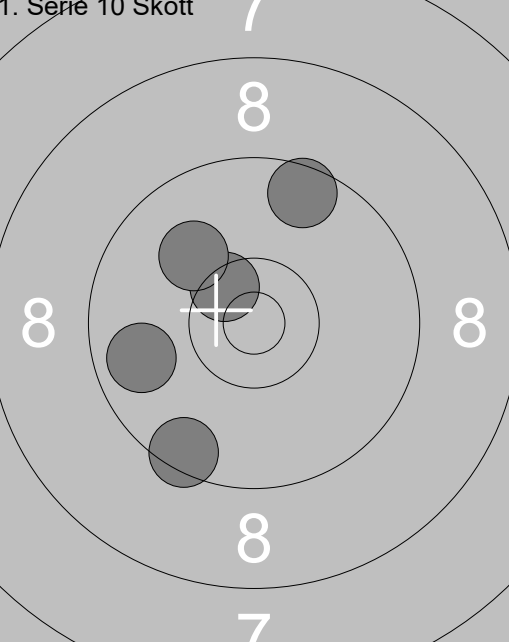
<p>1. Serie 10 Skott</p> 	<p>1: 10.5x ↘</p> <p>2: 9.6 ↑</p> <p>3: 10.0 ↘</p> <p>4: 9.8 ←</p> <p>5: 9.5 ↓</p>	<p>1. Serie 10 Skott</p> <p>6: 10.2 ←</p> <p>7: 9.7 ↓</p> <p>8: 9.4 ←</p> <p>9: 9.2 ↓</p> <p>10: 7.0 ←</p>
Serie 47.0		Serie 44.0
Total 232.0		Total 276.0

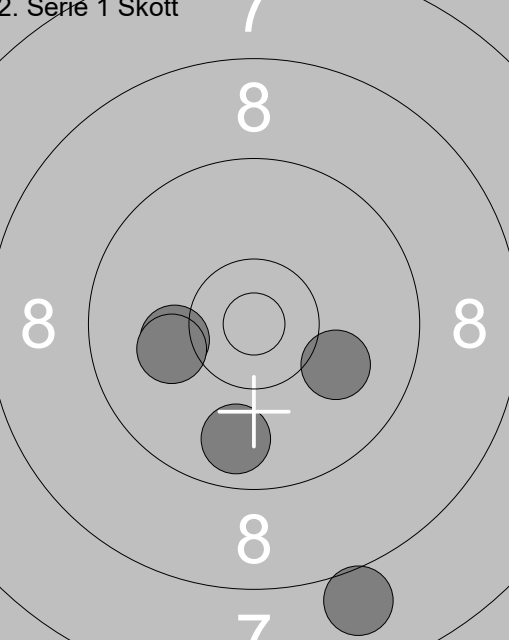
<p>2. Serie 1 Skott</p> 	<p>1: 8.0 ↓</p> <p>2: 9.8 ↓</p> <p>3: 10.1 ←</p> <p>4: 10.1 ←</p> <p>5: 10.0 →</p>	
Serie 47.0		
Total 323.0		

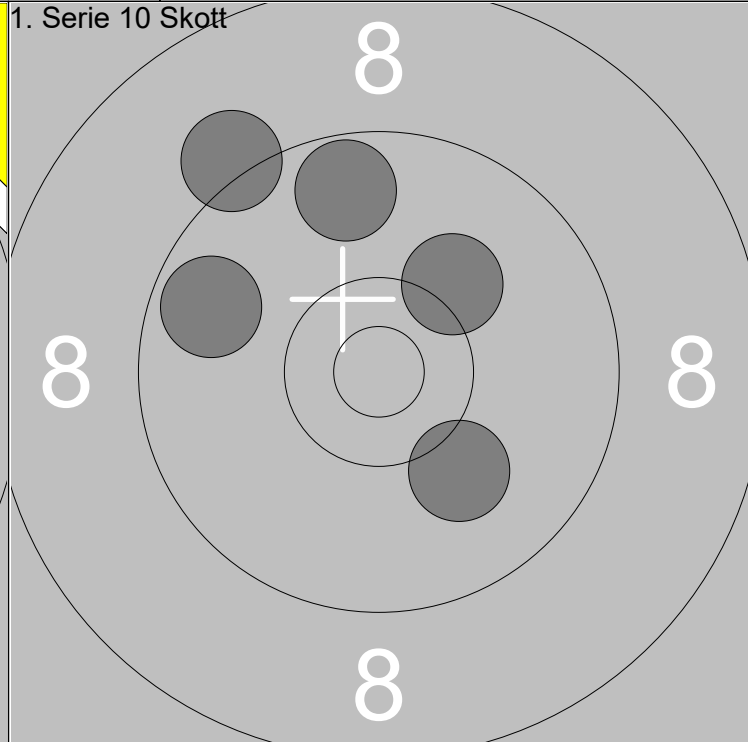
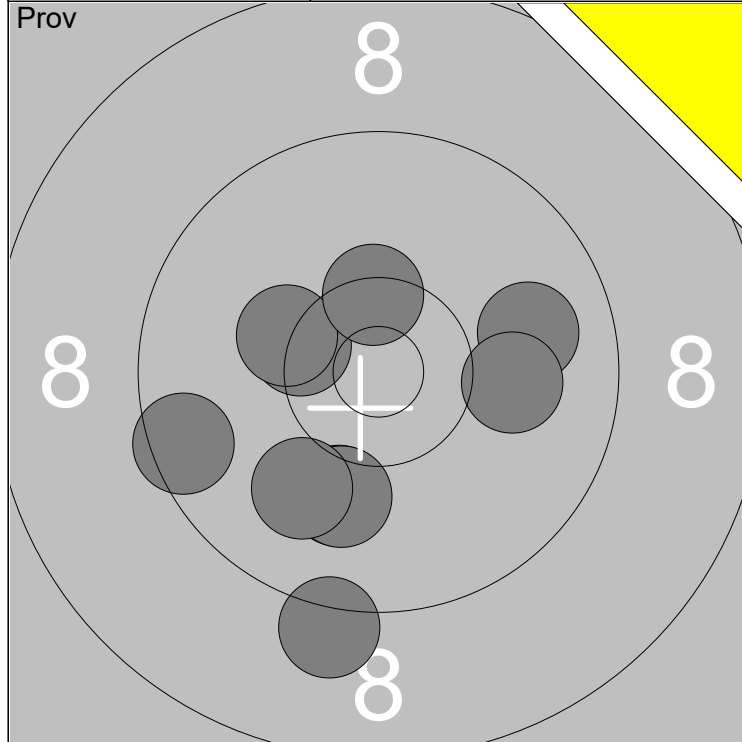

1: 9.2 ↓	6: 10.3 ↖	Serie	97
2: 10.1 ↓	7: 10.0 ↘		
3: 10.1 ↓	8: 9.9 →	Total	185
4: 10.4x ↖	9: 10.0 →		
5: 9.5 ↖	10: 10.4x ↑		

1: 10.1 ↓	Serie	47
2: 10.2 ↗		
3: 9.2 ↖	Total	232
4: 9.7 ↖		
5: 9.7 ↑		

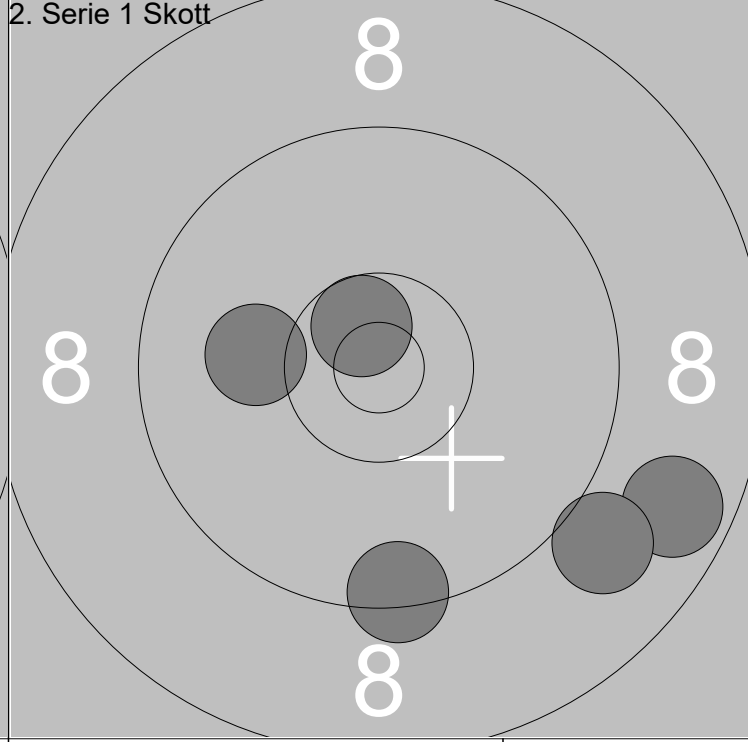
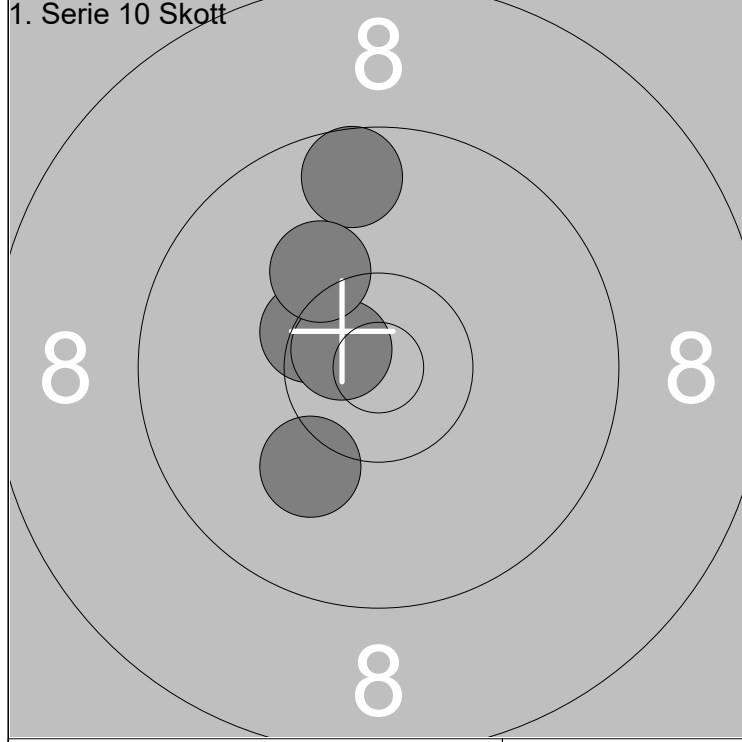

6: 9.6 ↑	Serie	49
7: 10.1 ↘		
8: 10.4x ↖	Total	281
9: 10.7x ↖		
10: 10.2 ↑		

1: 10.6x ↖	Serie	46
2: 8.7 ↘		
3: 10.1 ↖	Total	327
4: 9.0 ↘		
5: 9.4 ↓		

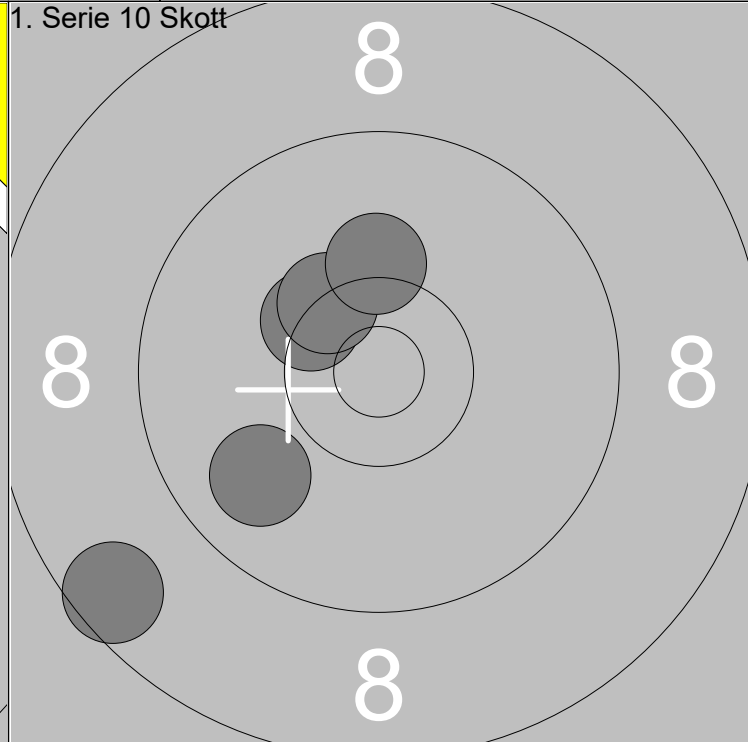
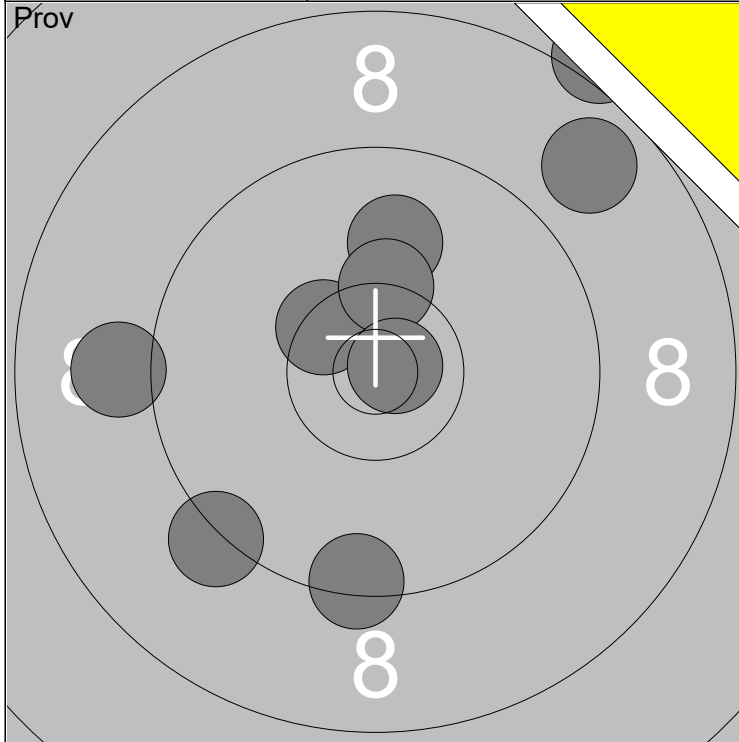

1: 8.8 ↗ 2: 8.1 ↗ 3: 9.3 ↙ 4: 10.0 ↑ 5: 10.4x ↖	6: 9.4 ↓ 7: 9.1 ← 8: 10.3x ↑ 9: 10.8x →	Serie	83
		Total	180

1: 10.4x ↖ 2: 10.4x ↖ 3: 10.2 ↑ 4: 9.9 ↙ 5: 8.6 ↙	Serie	47	
		Total	227

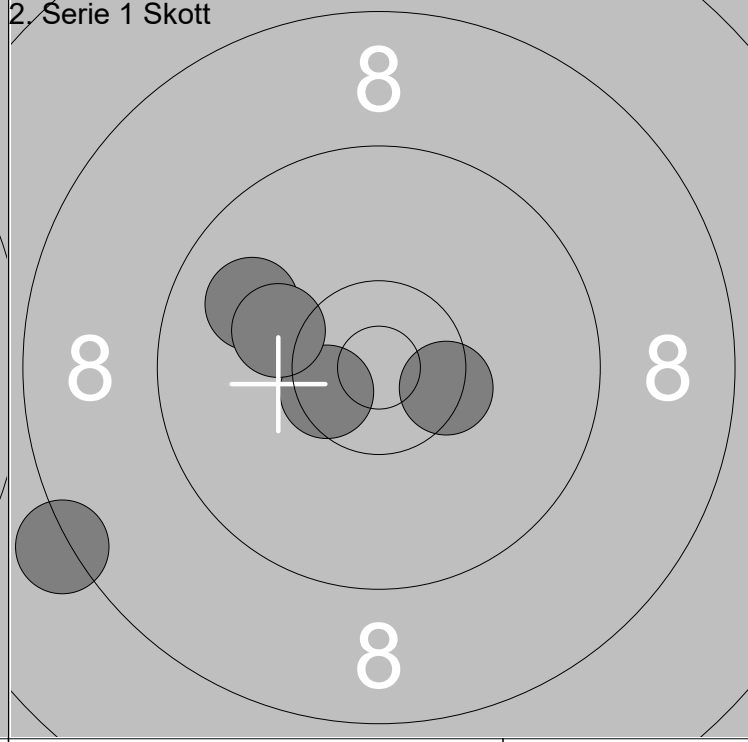
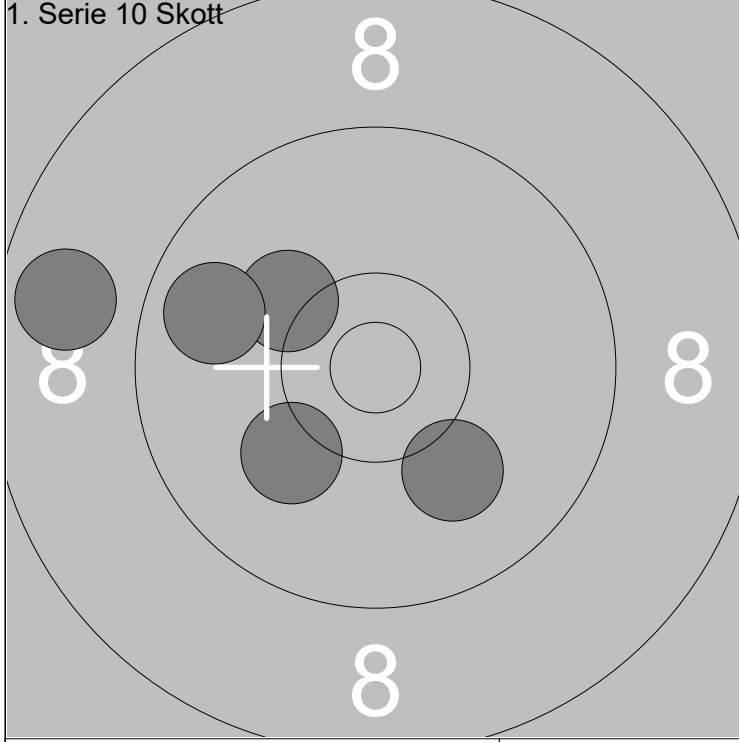

6: 10.2 ↗ 7: 8.8 ← 8: 10.1 ↙ 9: 9.8 ← 10: 10.1 ↙	Serie	47	
		Total	274

1: 10.5x ↖ 2: 9.9 ↖ 3: 10.4x → 4: 8.2 ↖ 5: 10.2 ↖	Serie	47	
		Total	321

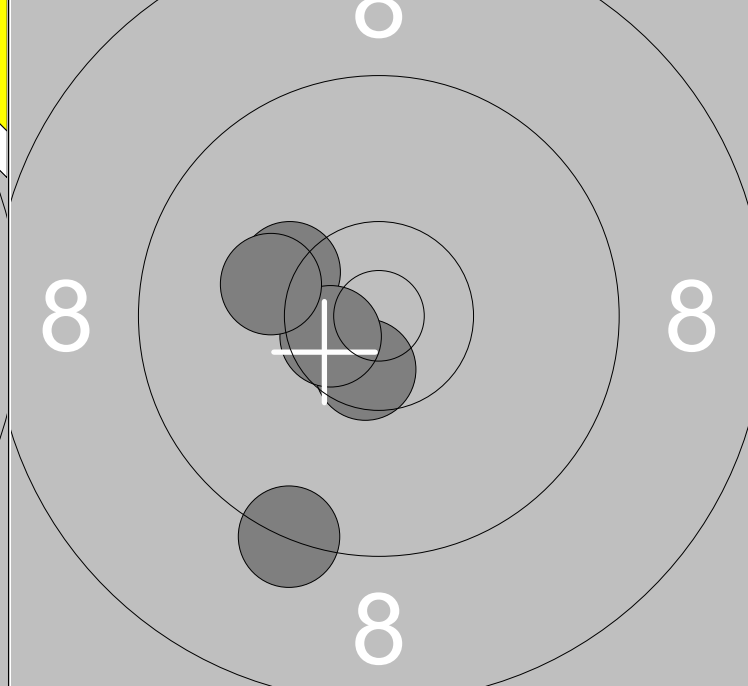
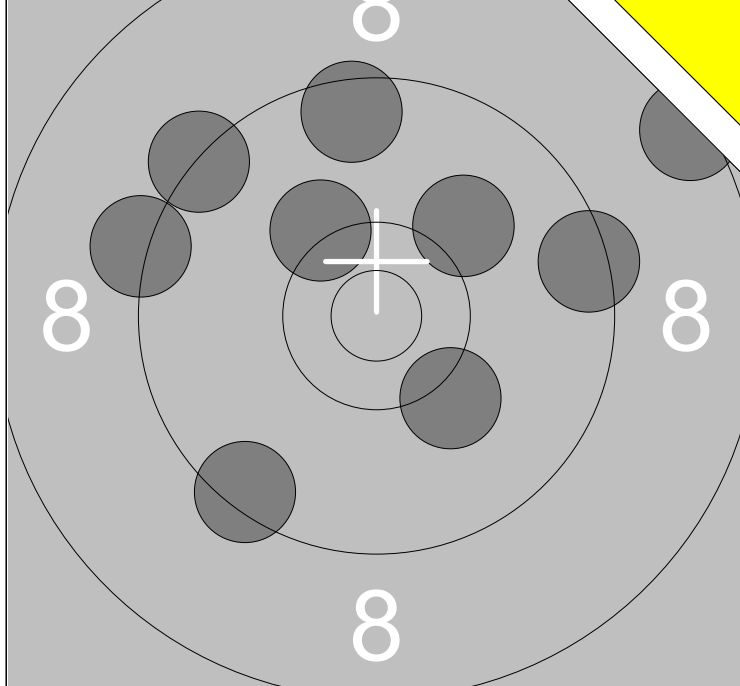

1: 9.3 ↖	6: 8.4 →	Serie	83
2: 9.5 ↑	7: 10.2 ↓		
3: 9.2 ←	8: 10.2 ↗	Total	180
4: 10.1 ↗	9: 9.4 ↓		
5: 9.4 →			

1: 10.3 ↖	Serie	49
2: 10.6x ↓		
3: 10.6x ←	Total	229
4: 10.2 ←		
5: 9.3 ↓		

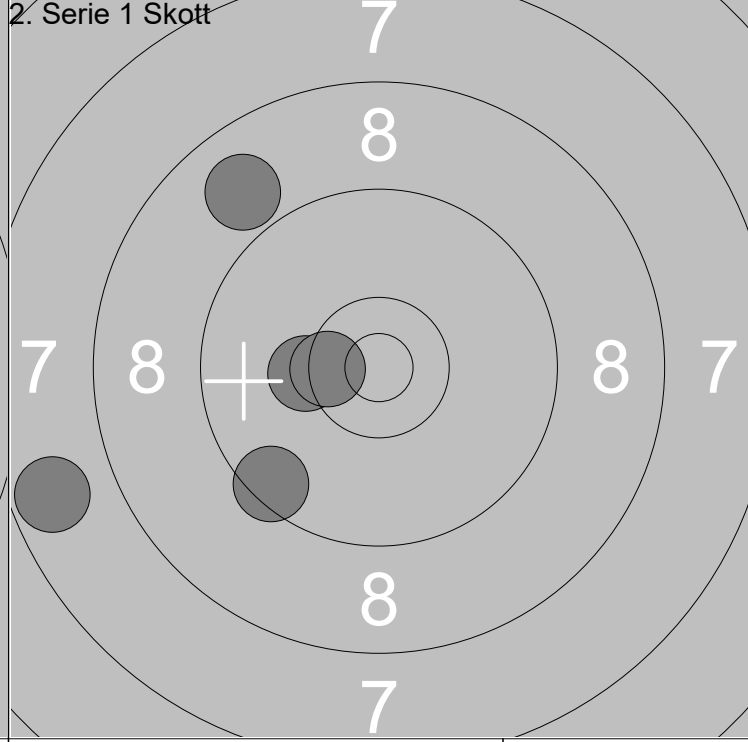
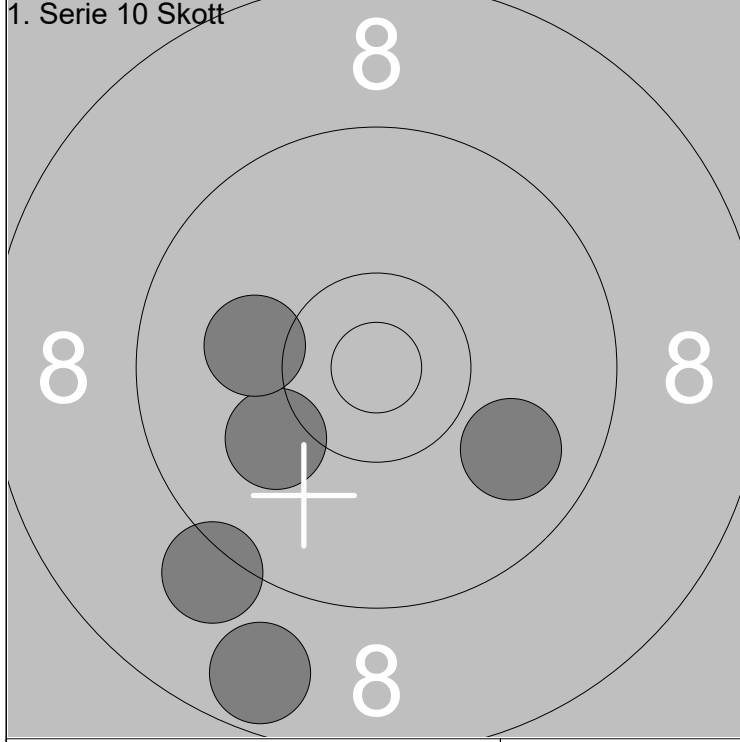

6: 10.1 ←	Serie	46
7: 9.1 ↓		
8: 9.9 ↓	Total	275
9: 10.1 ←		
10: 8.7 ↓		

1: 7.7 ←	Serie	44
2: 8.9 ↗		
3: 10.3 ←	Total	319
4: 10.5x ←		
5: 9.5 ↓		

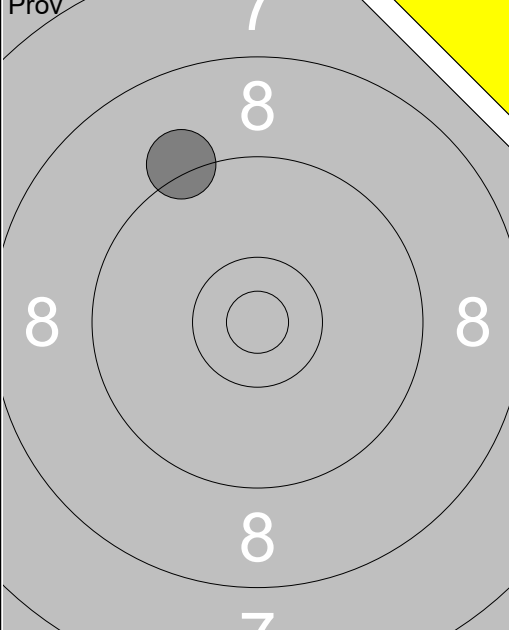
<p>Prov</p> 	<p>1: 0.0 ↓</p> <p>2: 9.2 ↑</p> <p>3: 10.5 ✗</p> <p>4: 10.1 ←</p> <p>5: 9.4 →</p> <p>6: 9.1 →</p> <p>7: 9.2 ←</p> <p>8: 10.3 →</p> <p>9: 10.2 ↓</p> <p>10: 9.6 ↖</p> <hr/> <p>Serie 85.0</p> <hr/> <p>Total 186.0</p>	<p>Prov</p> 	<p>11: 9.2 ↖</p> <hr/> <p>Serie 9.0</p> <hr/> <p>Total 186.0</p>
--	---	--	--

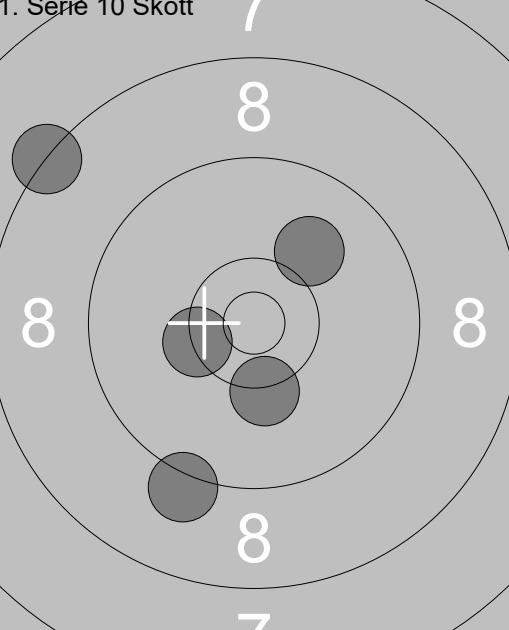
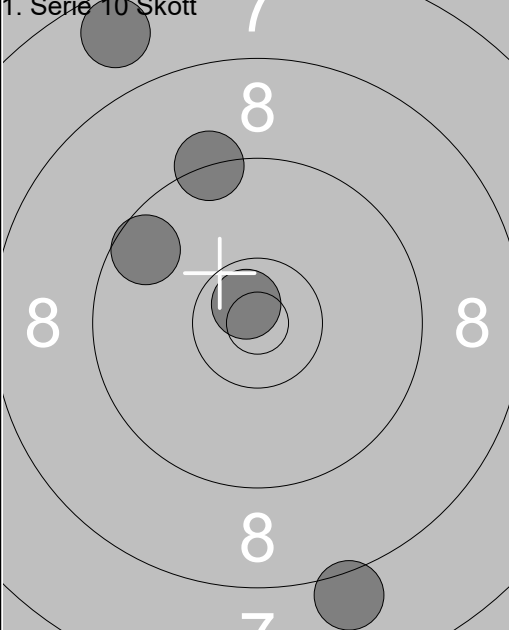
<p>1. Serie 10 Skott</p> 	<p>1: 8.3 ↖</p> <p>2: 9.2 ↓</p> <p>3: 10.3 ↓</p> <p>4: 10.0 ↗</p> <p>5: 10.4 ✗</p> <hr/> <p>Serie 47.0</p> <hr/> <p>Total 233.0</p>	<p>1. Serie 10 Skott</p> 	<p>6: 10.7 ✗</p> <p>7: 8.1 ↓</p> <p>8: 9.6 ↖</p> <p>9: 7.7 ↗</p> <p>10: 9.3 ↗</p> <hr/> <p>Serie 43.0</p> <hr/> <p>Total 276.0</p>
--	---	--	--

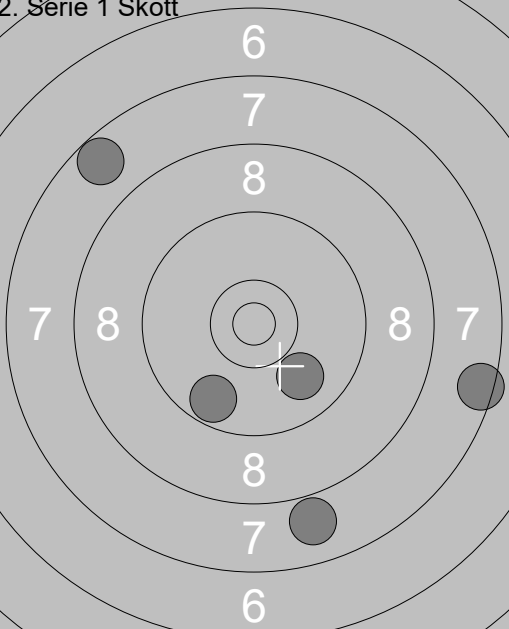
<p>2. Serie 1 Skott</p> 	<p>1: 7.9 ↓</p> <p>2: 7.7 ↗</p> <p>3: 7.5 →</p> <p>4: 9.9 ↓</p> <p>5: 9.7 ↓</p> <hr/> <p>Serie 39.0</p> <hr/> <p>Total 315.0</p>		
--	--	--	--

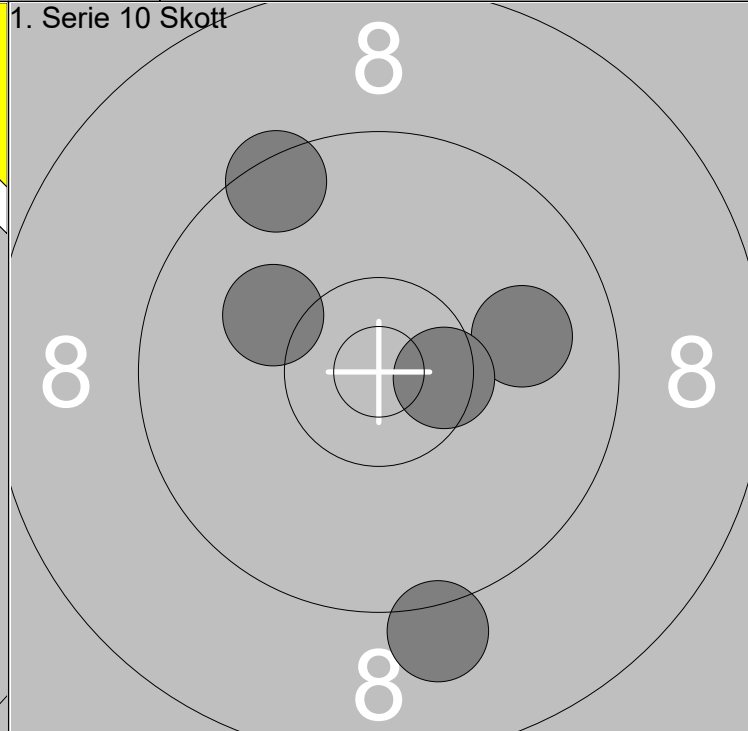
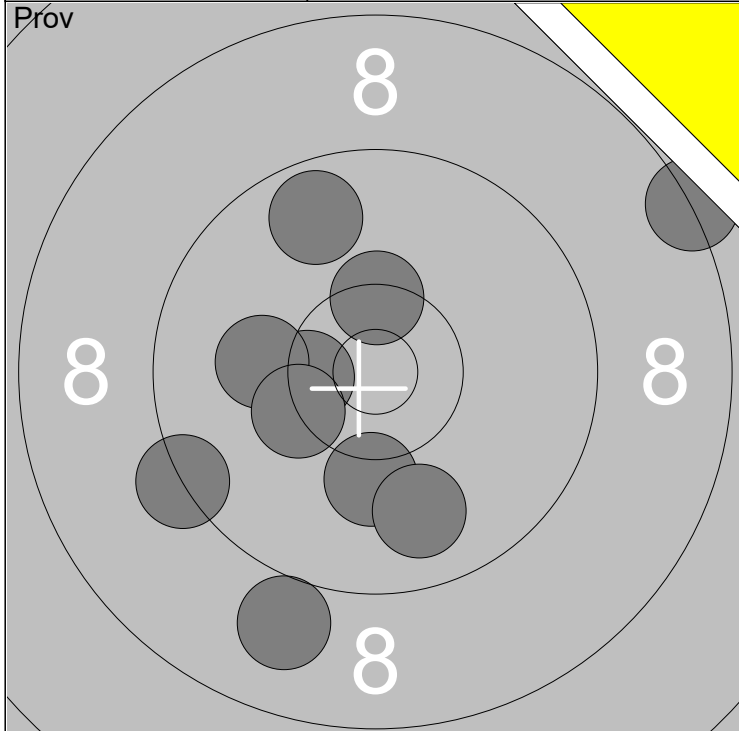

1: 9.0	2: 9.3	3: 8.3	4: 10.2	5: 10.4x	6: 9.7	7: 10.1	8: 10.3x	9: 10.4x	10: 9.9		
↓	↙	↗	↓	←	↖	←	↙	↑	↓	Serie	94
										Total	182

1: 9.1	2: 9.5	3: 9.9	4: 10.1	5: 10.5x							
↓	↖	→	↖	→							
										Serie	47
										Total	229

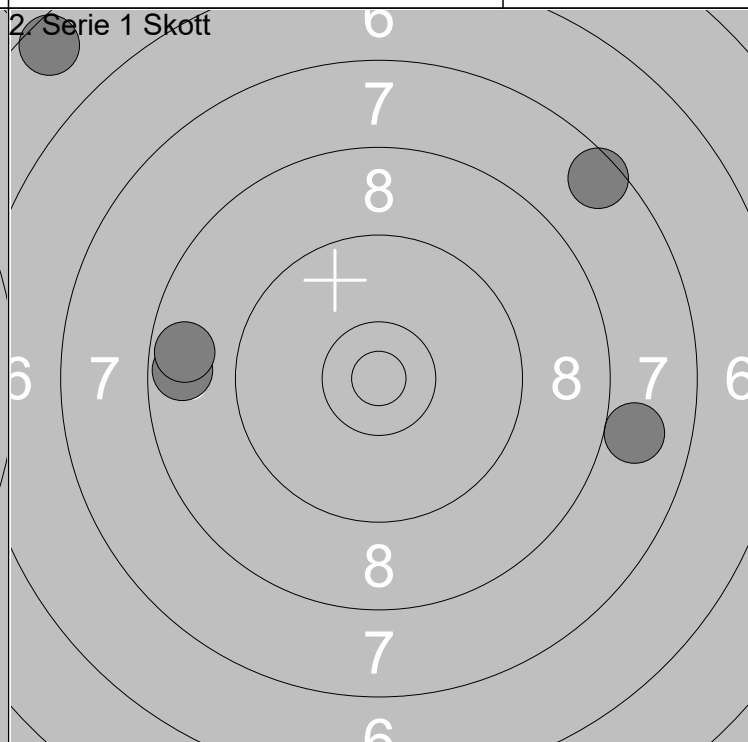
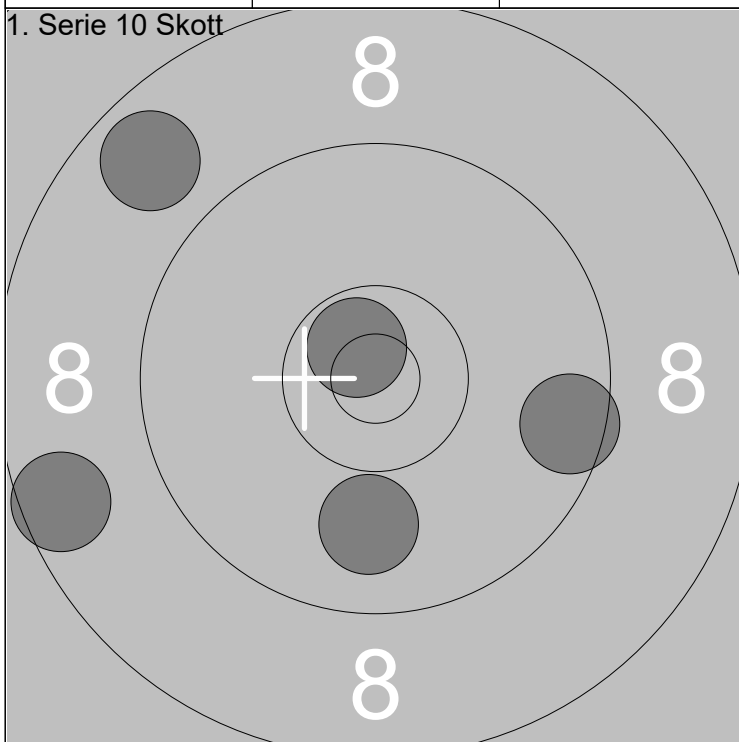

6: 8.8	7: 10.7x	8: 9.6	9: 8.6	10: 9.9							
↖	↖	→	←	↓							
										Serie	44
										Total	273

1: 8.7	2: 8.0	3: 5.6	4: 7.5	5: 8.7							
←	→	↖	↗	←							
										Serie	36
										Total	309

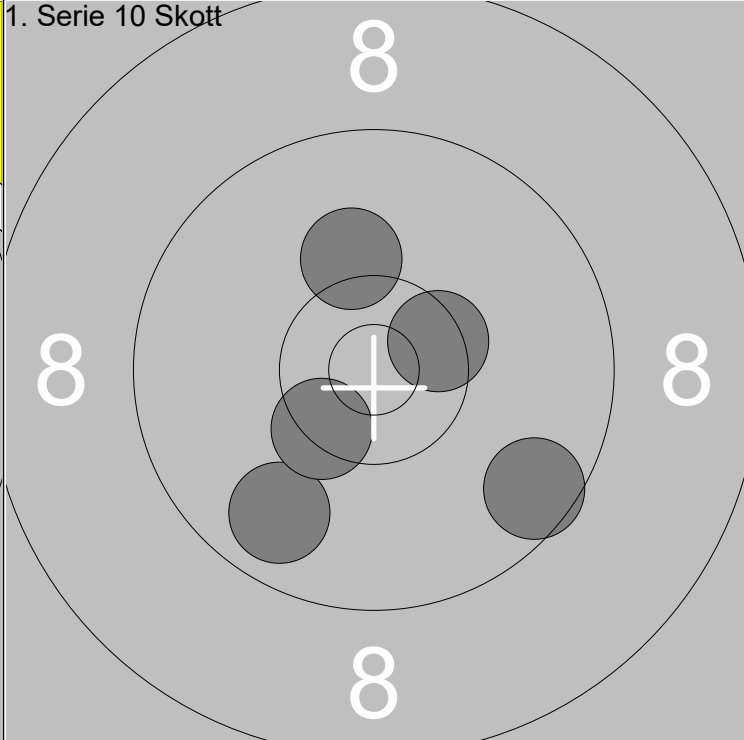
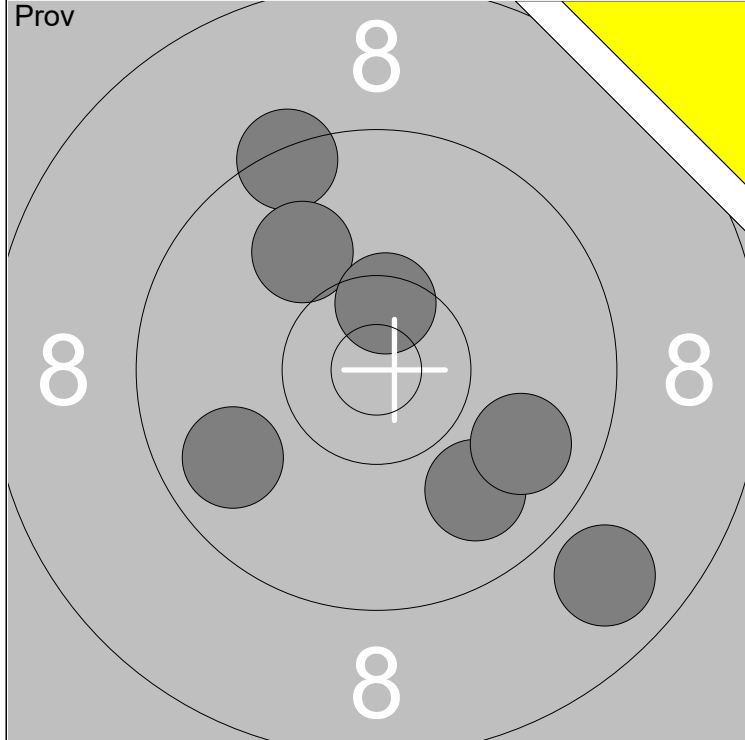

1: 8.8 ↘	6: 10.0 ↗	Serie	64
2: 9.9 ↘	7: 10.5x ↗		
3: 9.8 ↘		Total	179
4: 9.8 ↙			
5: 9.4 ↗			

1: 9.8 ↙	Serie	48
2: 10.2 ↗		
3: 10.5x ↗	Total	227
4: 10.4x ↙		
5: 9.6 ↘		

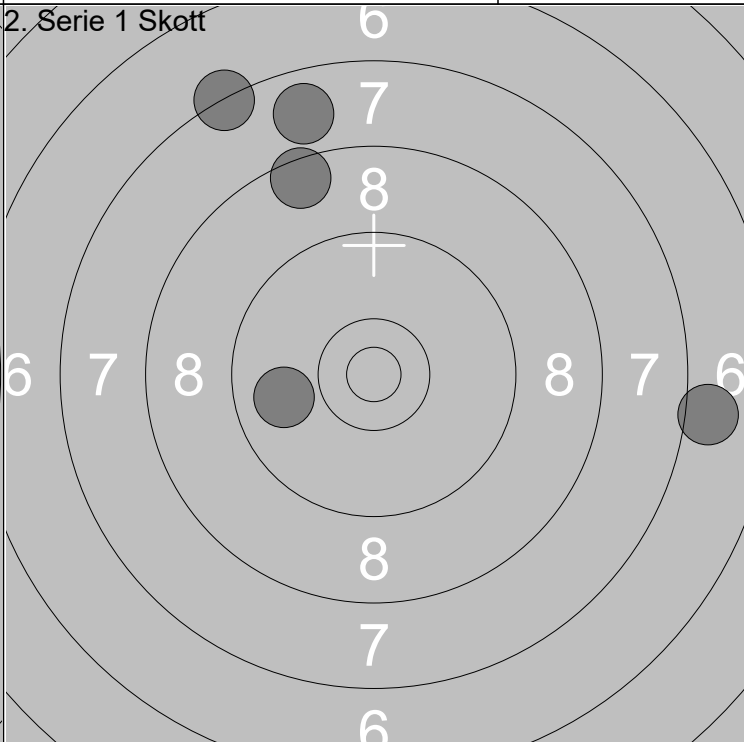
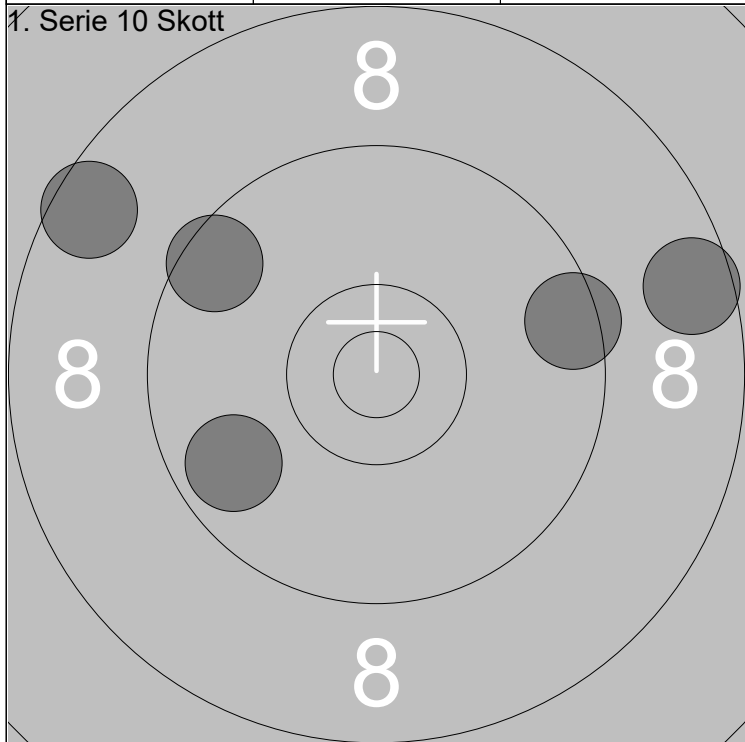

6: 8.6 ↗	Serie	43
7: 8.6 →		
8: 9.5 →	Total	270
9: 9.5 ↗		
10: 9.7 ↙		

1: 7.8 ↗	Serie	38
2: 9.9 ↙		
3: 7.3 ↗	Total	308
4: 7.0 →		
5: 8.5 ↗		

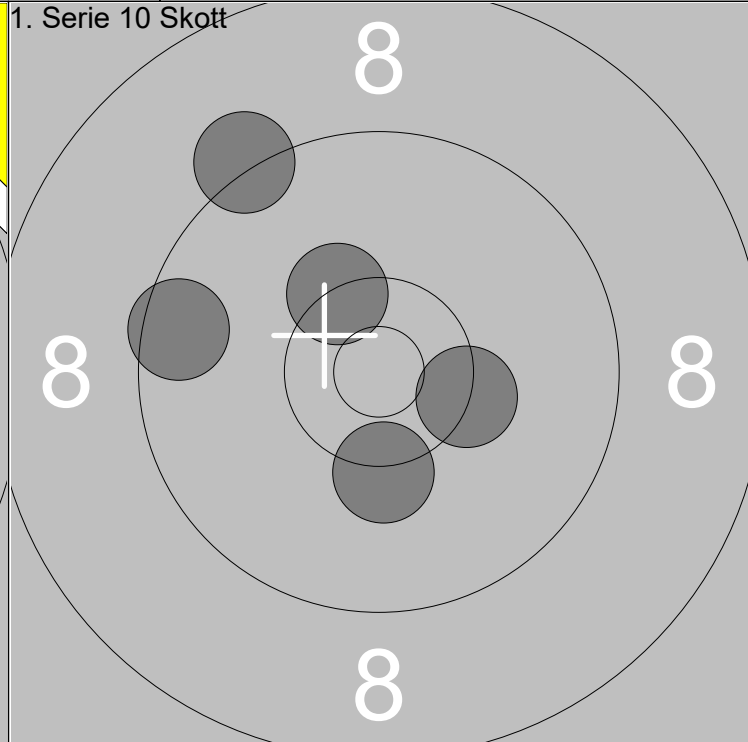
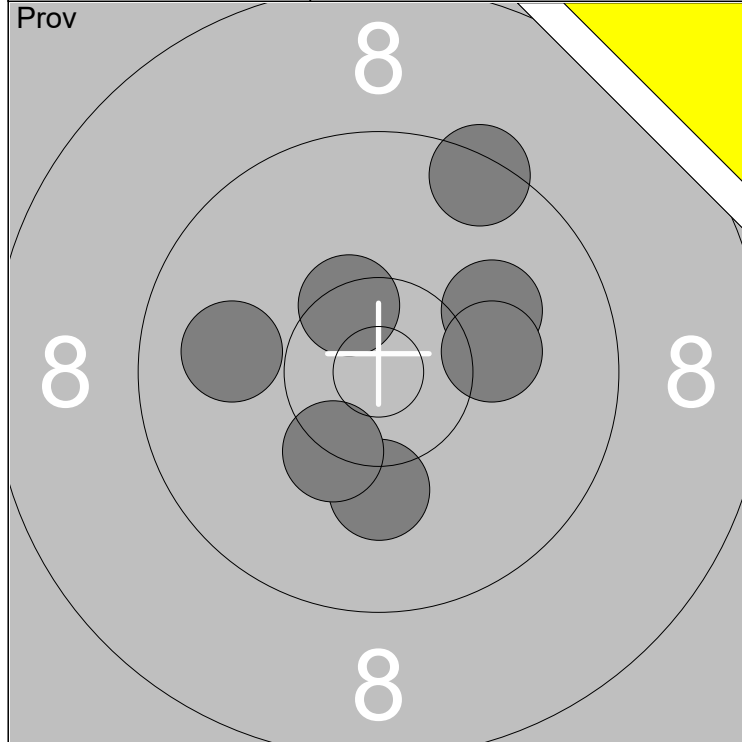

1: 10.1 ↗	6: 9.9 ←	Serie	68
2: 10.1 ↓	7: 10.4x ↗		
3: 10.2 →		Total	173
4: 10.3x ↘			
5: 9.4 ↗			

1: 10.3x ↖	Serie	48
2: 10.3x →		
3: 9.5 ←	Total	221
4: 10.3 ↓		
5: 9.2 ↖		

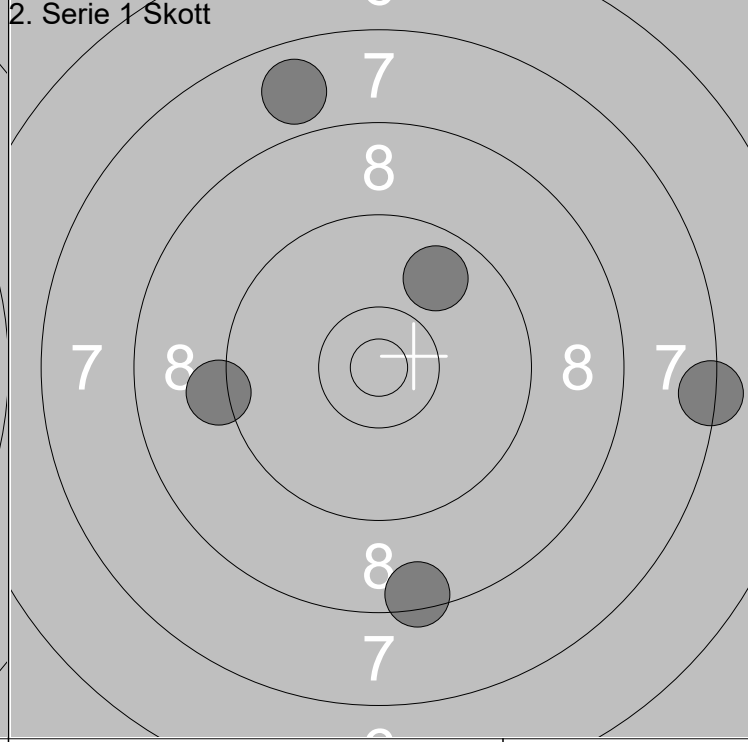
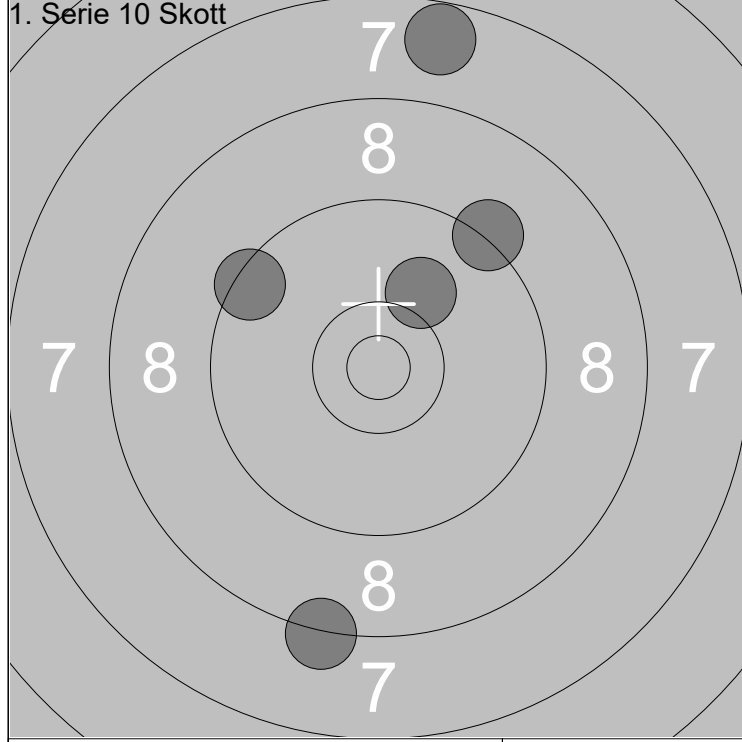

6: 9.3 ↗	Serie	43
7: 10.1 ↗		
8: 7.7 ↑	Total	264
9: 8.3 ↓		
10: 9.4 ←		

1: 7.8 ↖	Serie	40
2: 8.5 ↓		
3: 9.2 ←	Total	304
4: 7.4 →		
5: 9.8 ↗		

	<p>1: 9.5 ↗</p> <p>2: 9.6 ↘</p> <p>3: 10.9x↘</p> <p>4: 10.6x→</p> <p>5: 10.3x↓</p> <p>6: 9.6 ←</p> <p>7: 9.9 →</p> <p>8: 10.6x↓</p> <p>9: 10.5x↗</p> <p>10: 10.2↙</p>		<p>11: 9.6 ↙</p>
Serie 96.0		Serie 9.0	
Total 169.0		Total 169.0	

<p>1. Serie 10 Skott</p>	<p>1: 10.1 →</p> <p>2: 9.2 ↓</p> <p>3: 8.9 ↓</p> <p>4: 9.2 ↓</p> <p>5: 10.0 ↑</p>		<p>6: 9.5 ↗</p> <p>7: 7.9 ↙</p> <p>8: 10.0 ↖</p> <p>9: 10.2 ↖</p> <p>10: 9.1 ↙</p>
Serie 46.0		Serie 45.0	
Total 215.0		Total 260.0	

<p>2. Serie 1 Skott</p>	<p>1: 6.5 →</p> <p>2: 9.9 →</p> <p>3: 10.1 ↖</p> <p>4: 9.8 →</p> <p>5: 9.3 →</p>		
Serie 43.0			
Total 303.0			

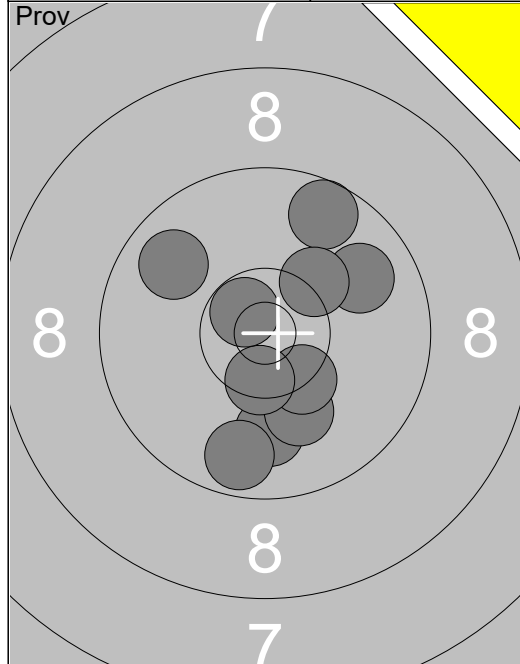

1:	9.6	↗
2:	9.9	↗
3:	10.0	↓
4:	9.8	↖
5:	10.1	↓
6:	9.7	↓
7:	10.4x	↘
8:	10.2	↗
9:	10.5x	↓
10:	10.7x	↘
Serie		96.0
Total		165.0

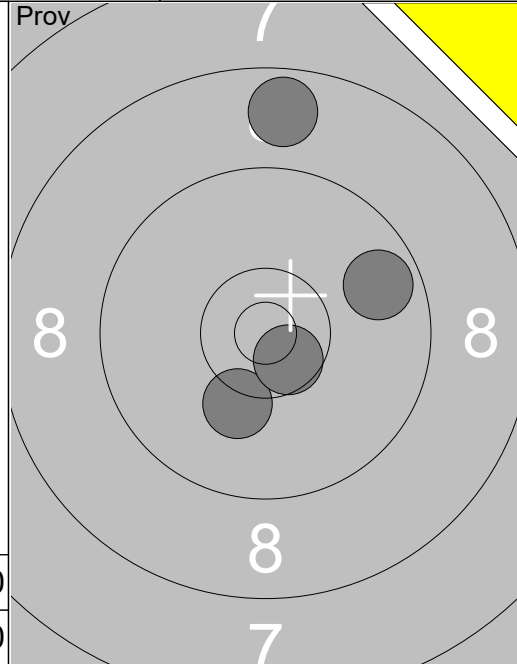

11:	10.2	↓
12:	8.7	↑
13:	9.7	↗
14:	10.6x	↘
Serie		37.0
Total		165.0

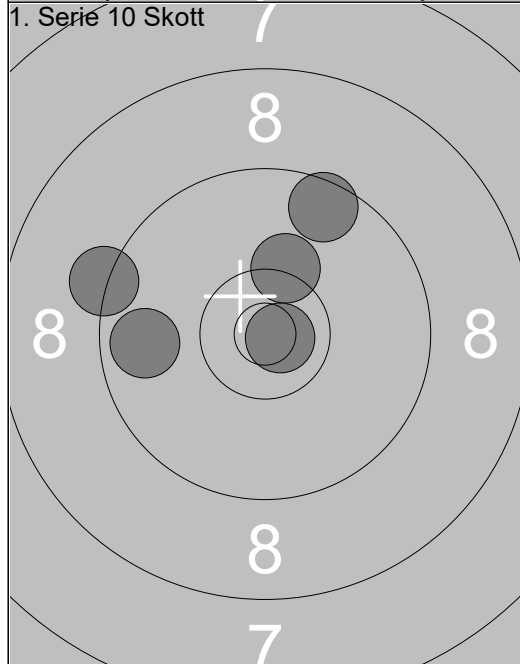

1:	9.6	↗
2:	9.3	←
3:	10.3	↑
4:	9.7	←
5:	10.8x	→
Serie		47.0
Total		212.0

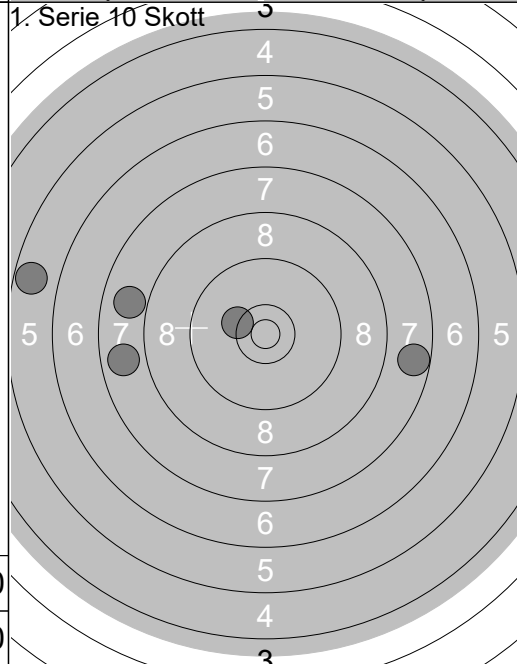

6:	7.8	←
7:	7.9	←
8:	7.7	→
9:	10.3	↖
10:	5.7	←
Serie		36.0
Total		248.0

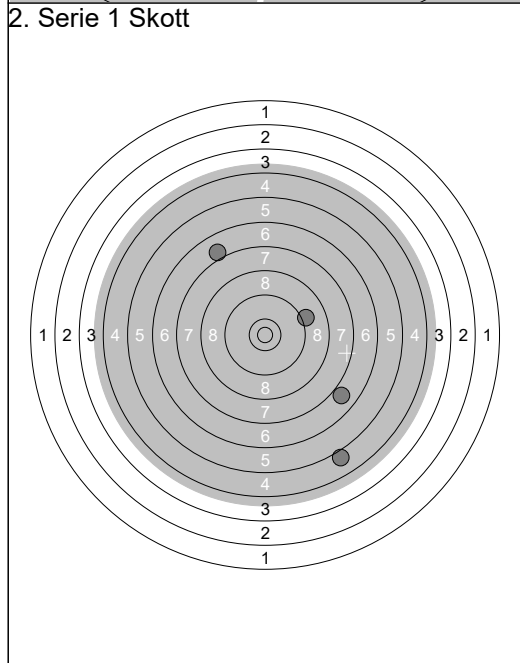

1:	9.1	↗
2:	7.0	↓
3:	5.0	↓
4:	7.0	↗
5:	0.0	→
Serie		28.0
Total		276.0

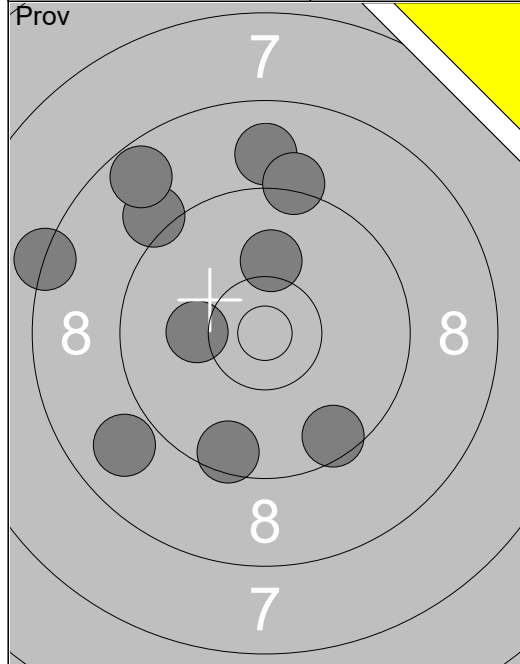

1:	8.9	↙
2:	9.5	↘
3:	9.1	↗
4:	8.7	↗
5:	8.3	↖
6:	10.1	↑
7:	8.9	↑
8:	9.2	↑
9:	9.5	↘
10:	10.2	←
Serie	88.0	
Total	154.0	

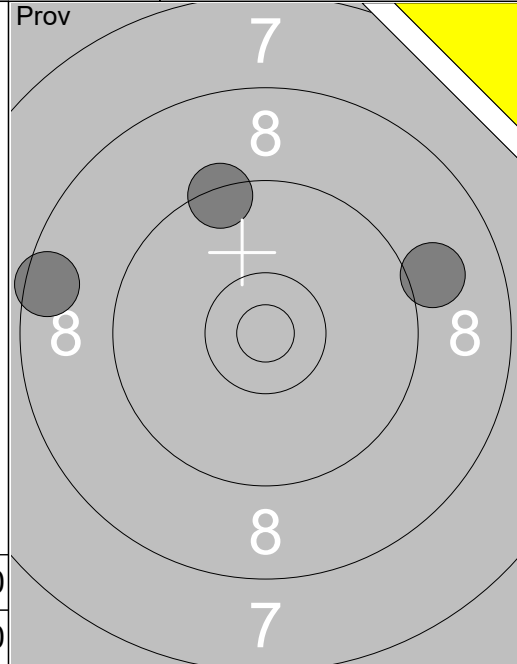

11:	8.5	←
12:	9.0	→
13:	9.4	↗
Serie	26.0	
Total	154.0	

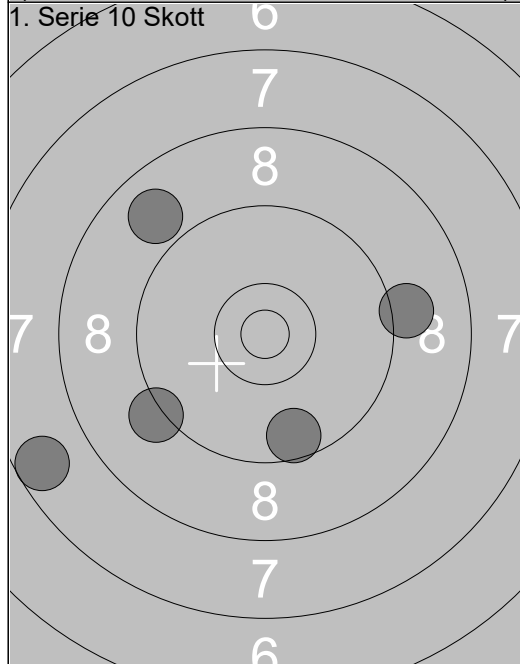

1:	8.9	↖
2:	9.6	↘
3:	7.6	←
4:	9.1	→
5:	9.2	↙
Serie	42.0	
Total	196.0	

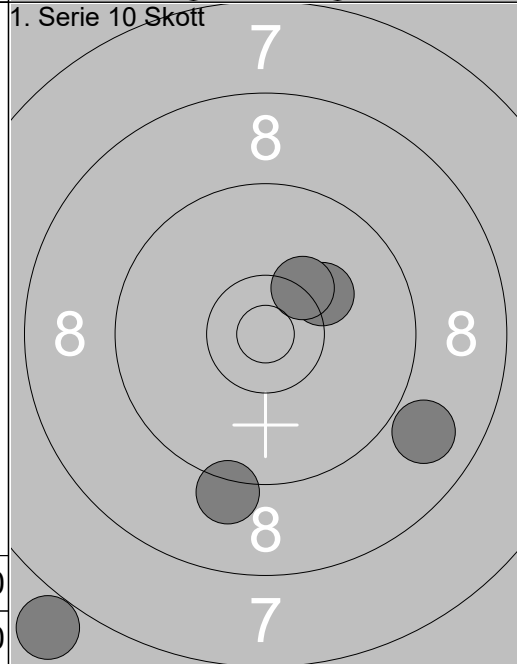

6:	9.2	↘
7:	10.2	↗
8:	10.3x	↗
9:	6.9	↙
10:	8.9	↘
Serie	43.0	
Total	239.0	

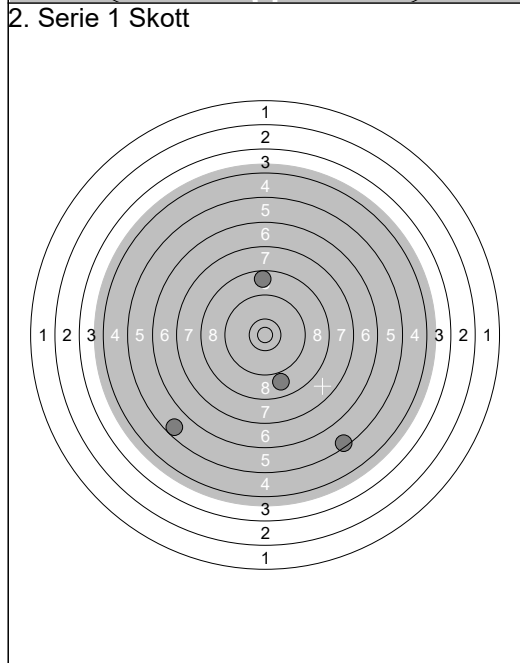

1:	8.6	↑
2:	0.0	→
3:	5.6	↙
4:	5.5	↘
5:	8.9	↘
Serie	26.0	
Total	265.0	

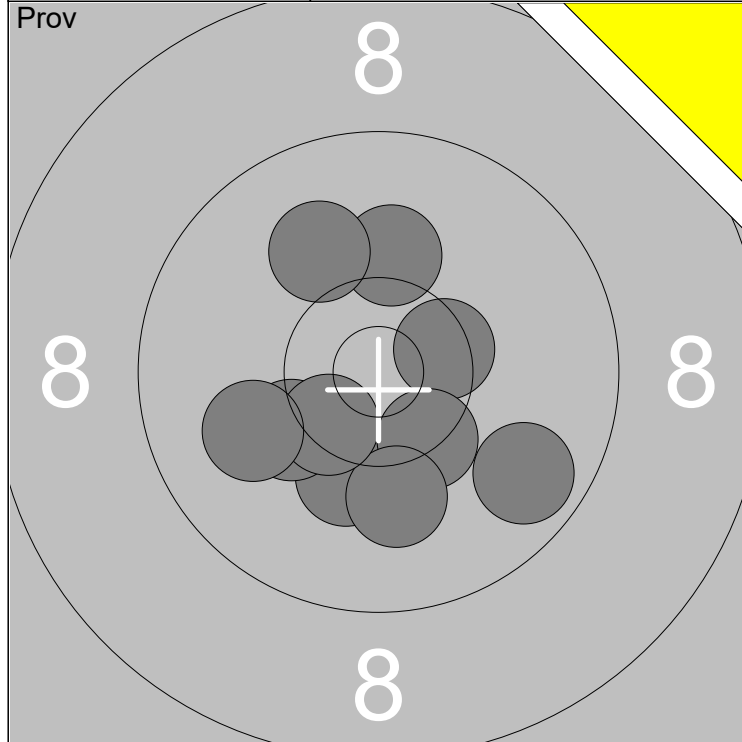

1: 10.5x →	6: 10.1 ↑	Serie	99
2: 9.7 ↘	7: 10.1 ↓		
3: 10.2 ↓	8: 10.0 ↗	Total	180
4: 10.2 ↙	9: 10.4x ↘		
5: 10.4x ↘	10: 10.0 ←		

1: 9.7 ↓	Serie	44
2: 9.0 ↗		
3: 9.6 ↓	Total	224
4: 8.4 ↘		
5: 9.5 ←		

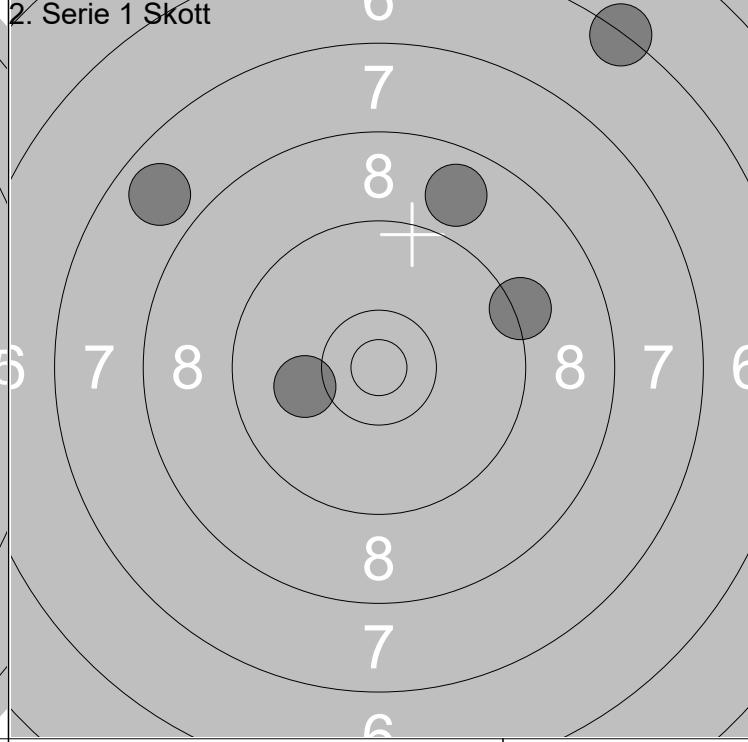
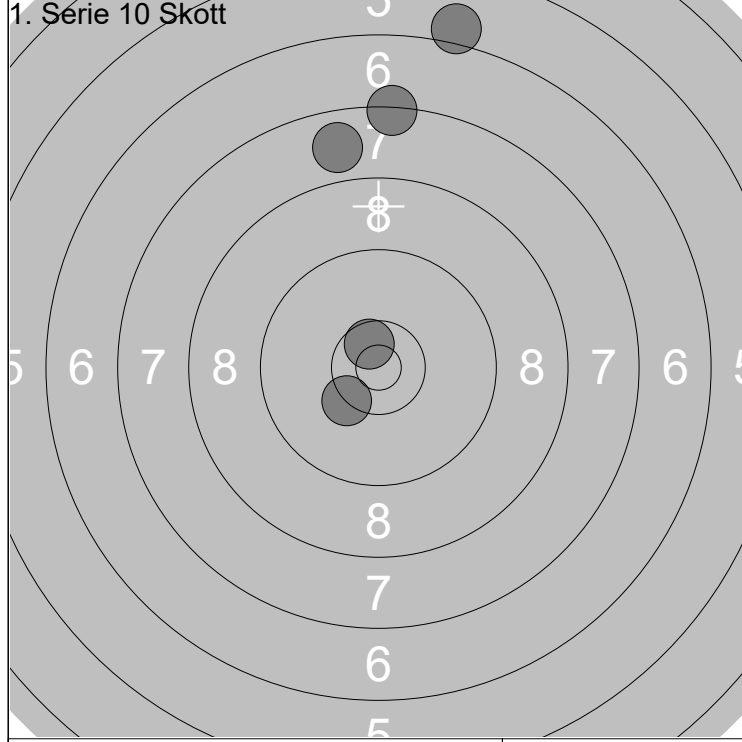

6: 10.6x ↗	Serie	40
7: 7.4 ↑		
8: 10.3x ↙	Total	264
9: 7.8 ↑		
10: 6.1 ↑		

1: 10.1 ←	Serie	40
2: 6.3 ↗		
3: 8.8 ↗	Total	304
4: 7.8 ↙		
5: 9.2 ↗		

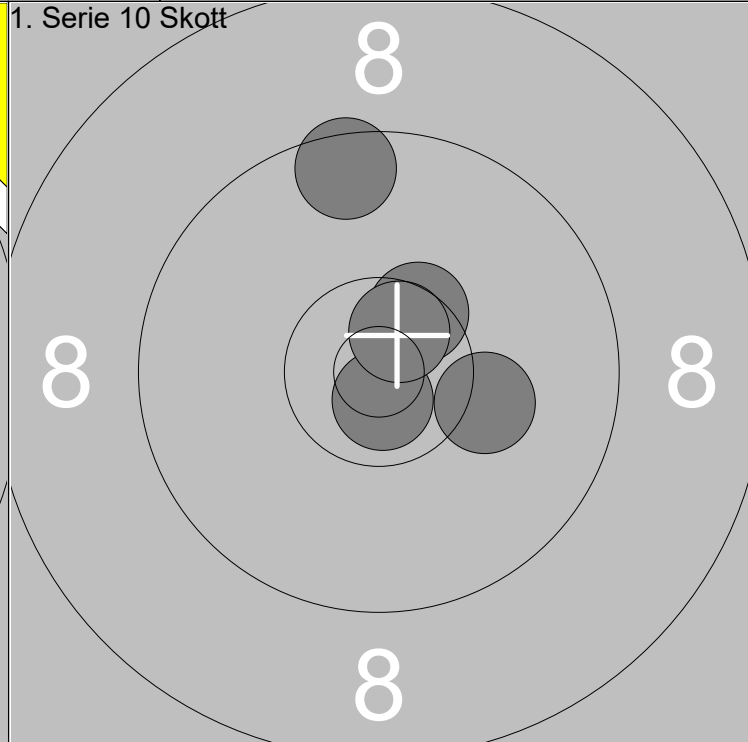
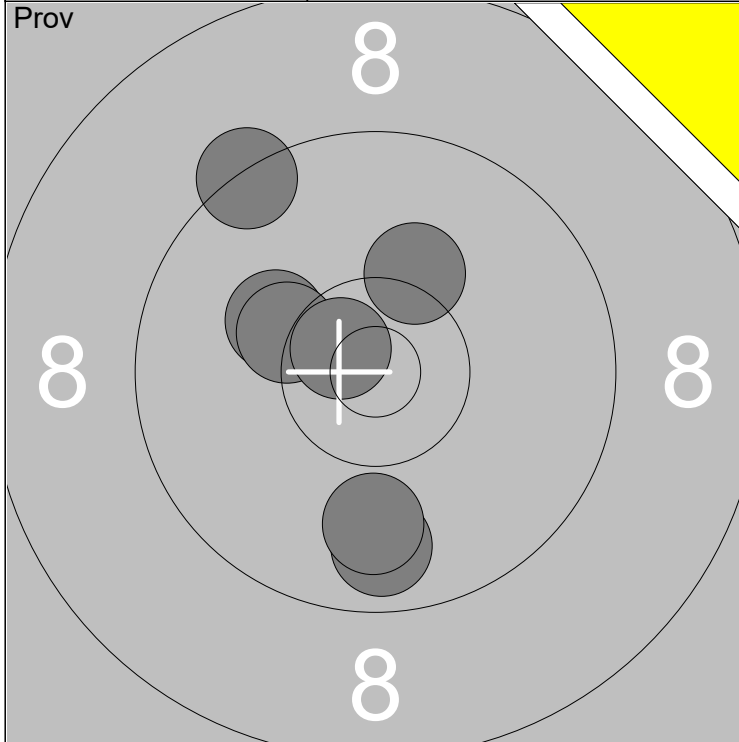

1: 9.4 ↗	6: 10.2 ↗	Serie	67
2: 9.8 ↓	7: 10.7x ↖		
3: 9.9 ↓		Total	174
4: 10.2 ↗			
5: 10.3 ↖			

1: 10.5x ↗	Serie	49
2: 10.2 →		
3: 10.8x ↓	Total	223
4: 10.6x ↗		
5: 9.5 ↑		

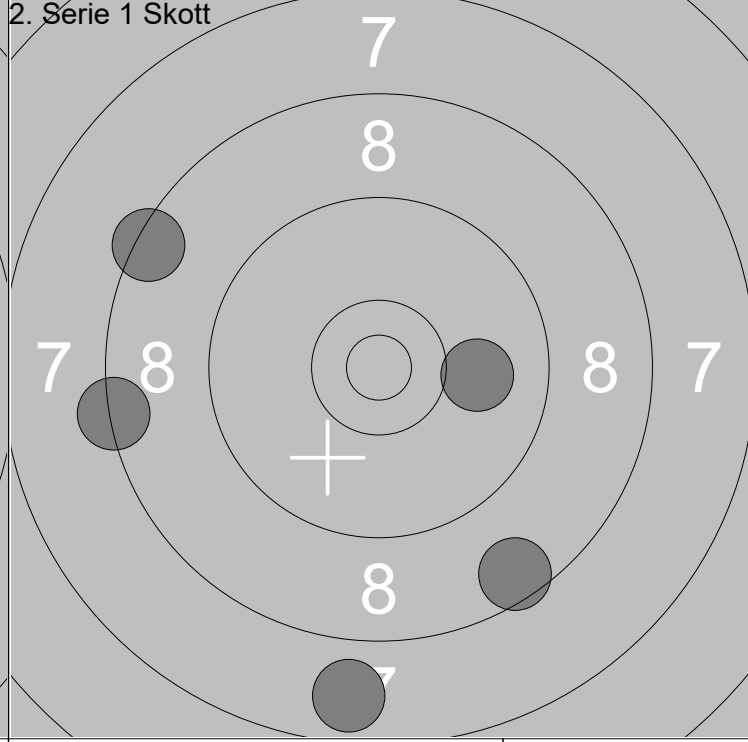
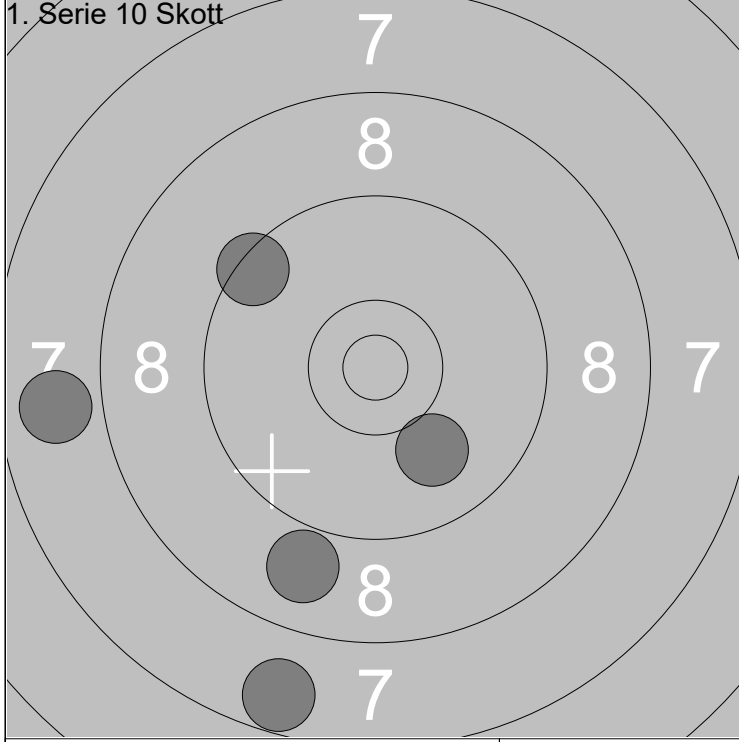

6: 7.7 ↓	Serie	41
7: 10.0 ↓		
8: 9.4 ↗	Total	264
9: 7.9 ←		
10: 8.9 ↓		

1: 8.3 ←	Serie	41
2: 7.8 ↓		
3: 8.6 ↓	Total	305
4: 8.4 ↗		
5: 10.0 →		

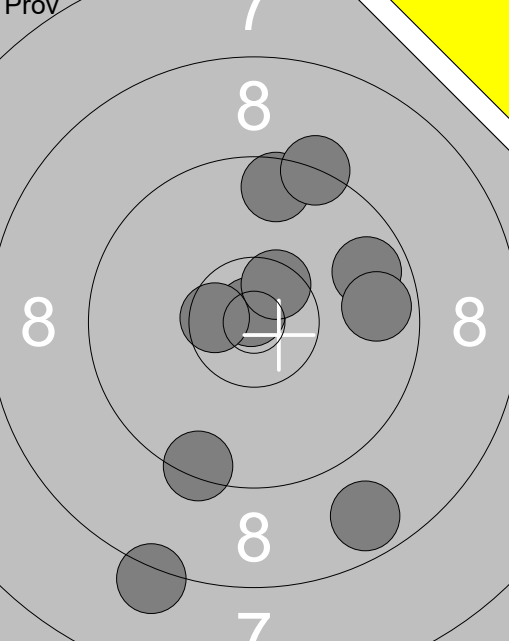
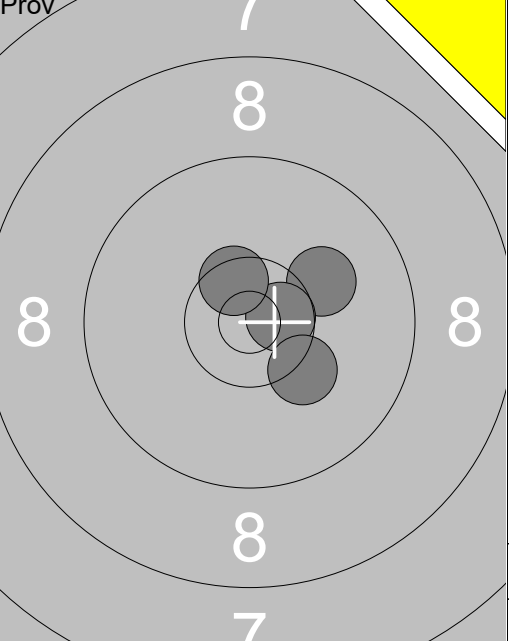
	<p>1: 8.2 ↓</p> <p>2: 9.4 ↓</p> <p>3: 8.7 ↓</p> <p>4: 10.8x ↗</p> <p>5: 10.5x ↗</p> <p>6: 9.6 ↑</p> <p>7: 9.7 →</p> <p>8: 9.3 ↑</p> <p>9: 9.7 →</p> <p>10: 10.6x ←</p>		<p>11: 10.1 ↗</p> <p>12: 10.6x ↗</p> <p>13: 10.2 ↓</p> <p>14: 10.5x ↗</p>
Serie 91.0		Serie 40.0	
Total 192.0		Total 192.0	

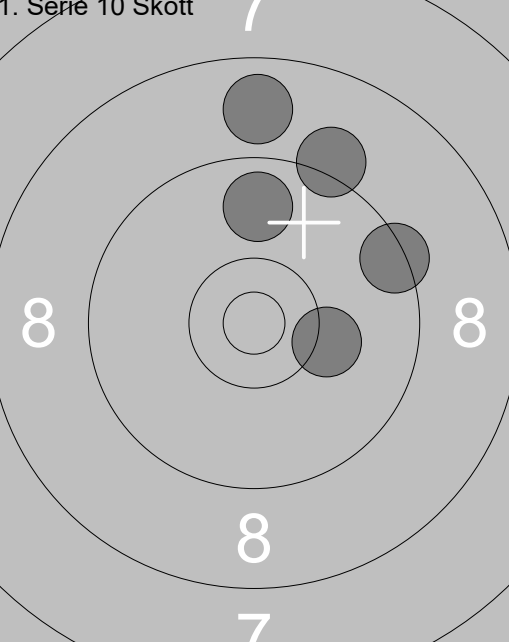
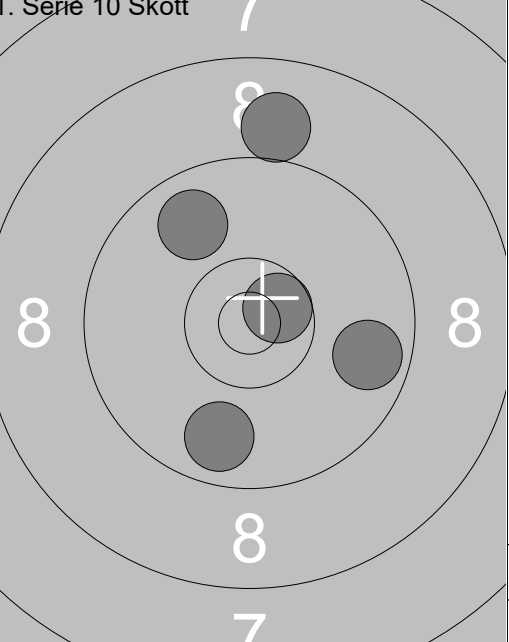
<p>1. Serie 10 Skott</p> 	<p>1: 9.8 ↑</p> <p>2: 9.4 →</p> <p>3: 8.8 ↑</p> <p>4: 10.2 →</p> <p>5: 9.2 ↗</p>	<p>1. Serie 10 Skott</p> 	<p>6: 9.8 ↗</p> <p>7: 9.7 →</p> <p>8: 9.0 ↑</p> <p>9: 9.8 ↓</p> <p>10: 10.6x ↗</p>
Serie 45.0		Serie 46.0	
Total 237.0		Total 283.0	

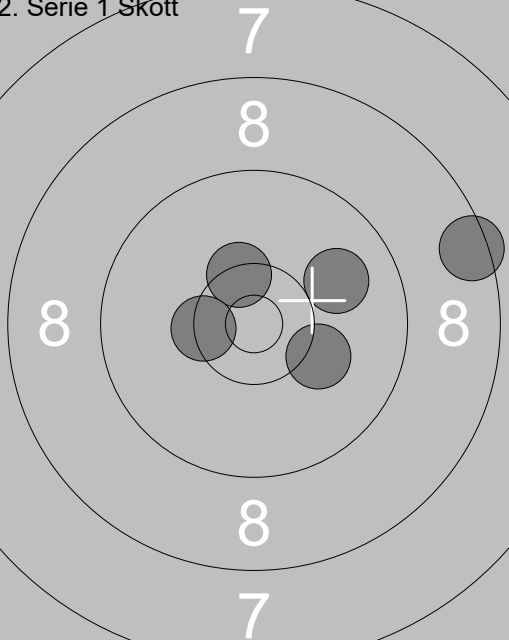
<p>2. Serie 1 Skott</p> 	<p>1: 10.2 ↘</p> <p>2: 10.4x ↗</p> <p>3: 8.5 →</p> <p>4: 10.4x ←</p> <p>5: 9.9 →</p>		
Serie 47.0			
Total 330.0			

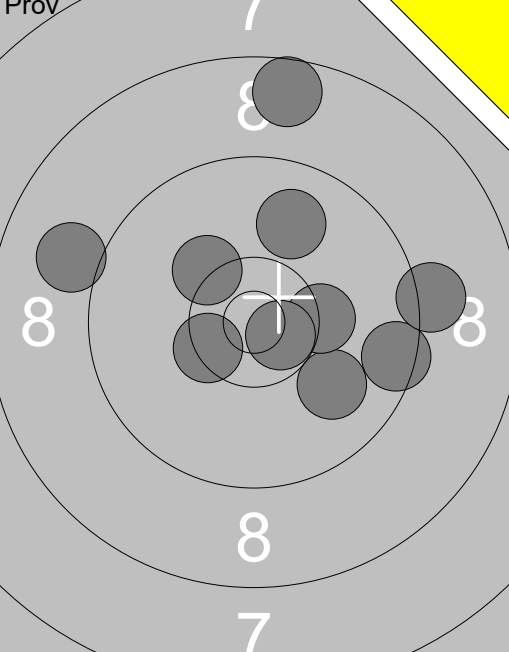
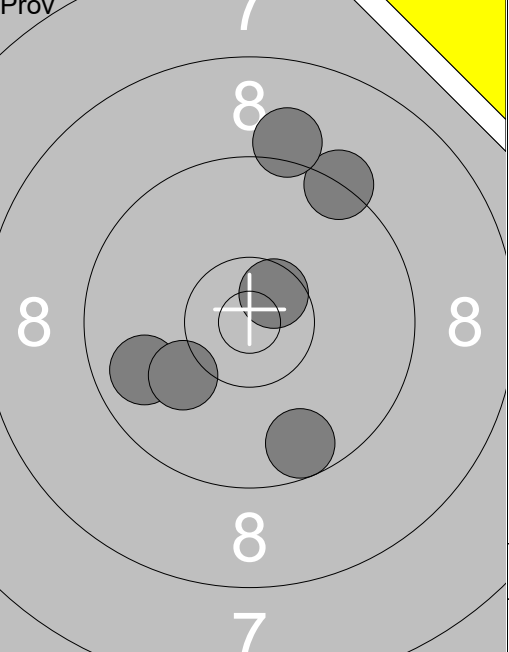
	<p>1: 9.5 →</p> <p>2: 8.6 ↑</p> <p>3: 10.0 ↘</p> <p>4: 9.9 ↑</p> <p>5: 10.3 →</p> <p>6: 10.7x↘</p> <p>7: 9.0 ←</p> <p>8: 9.2 →</p> <p>9: 10.2 ↗</p> <p>10: 10.4x↙</p>		<p>11: 10.6x↗</p> <p>12: 9.3 ↗</p> <p>13: 9.6 ↘</p> <p>14: 9.8 ←</p> <p>15: 10.1 ↙</p> <p>16: 9.1 ↑</p>
Serie 94.0		Serie 56.0	
Total 188.0		Total 188.0	

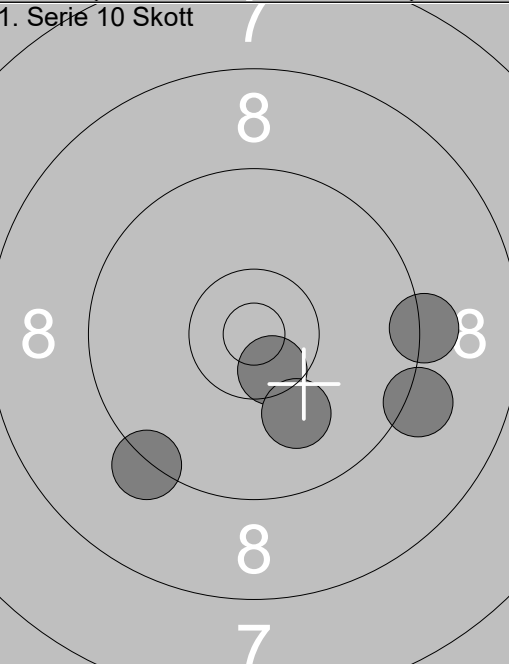
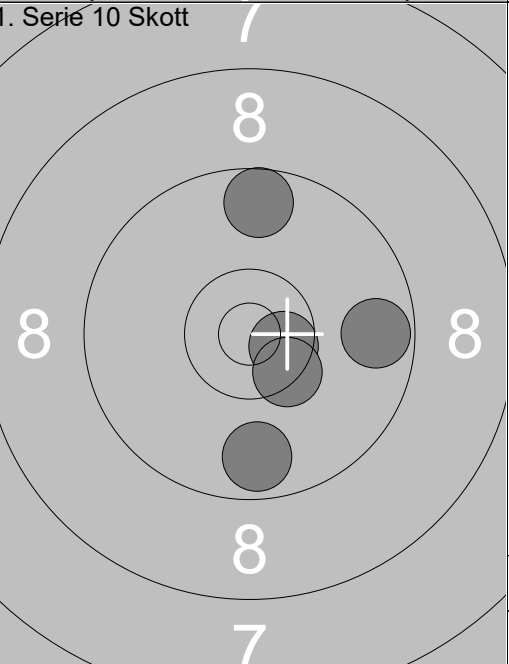
<p>1. Serie 10 Skott</p> 	<p>1: 9.3 →</p> <p>2: 9.3 ↙</p> <p>3: 10.5x↘</p> <p>4: 9.2 →</p> <p>5: 10.1 ↘</p>	<p>1. Serie 10 Skott</p> 	<p>6: 9.6 ↑</p> <p>7: 9.7 ↘</p> <p>8: 10.6x↘</p> <p>9: 9.7 →</p> <p>10: 10.4x↘</p>
Serie 47.0		Serie 47.0	
Total 235.0		Total 282.0	

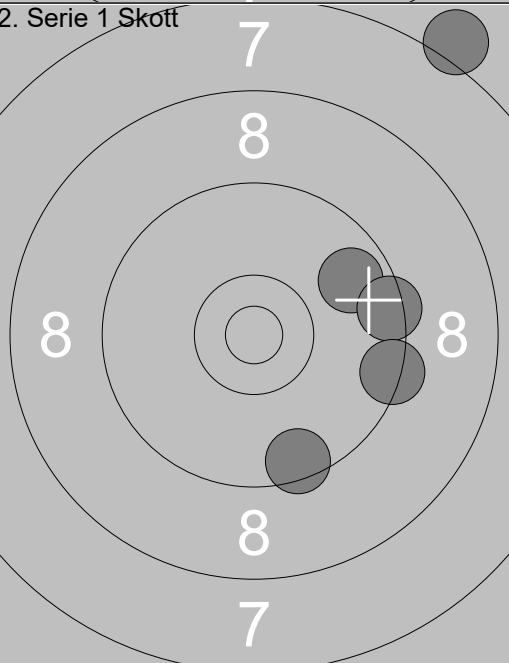
<p>2. Serie 1 Skott</p> 	<p>1: 9.5 ↓</p> <p>2: 7.1 ↗</p> <p>3: 9.7 ↗</p> <p>4: 9.5 →</p> <p>5: 9.4 →</p>		
Serie 43.0			
Total 325.0			

<p>Prov</p>	<p>1: 7.8 ←</p> <p>2: 7.6 ↘</p> <p>3: 10.5x↘</p> <p>4: 9.1 ↗</p> <p>5: 9.5 ↗</p> <p>6: 9.9 ↗</p> <p>7: 9.7 ↑</p> <p>8: 9.6 ↗</p> <p>9: 9.9 ↓</p> <p>10: 9.9 →</p>	<p>Prov</p>	<p>11: 10.6x↘</p> <p>12: 9.3 →</p> <p>13: 10.2 ↗</p> <p>14: 10.7x↘</p>
Serie 87.0		Serie 39.0	
Total 186.0		Total 186.0	

<p>1. Serie 10 Skott</p>	<p>1: 10.4x↘</p> <p>2: 9.9 →</p> <p>3: 9.2 ↘</p> <p>4: 9.4 ↘</p> <p>5: 9.0 ↘</p>	<p>1. Serie 10 Skott</p>	<p>6: 7.9 ↗</p> <p>7: 9.5 ↘</p> <p>8: 10.1 ↗</p> <p>9: 10.4x↘</p> <p>10: 9.9 ↓</p>
Serie 46.0		Serie 45.0	
Total 232.0		Total 277.0	

<p>2. Serie 1 Skott</p>	<p>1: 9.0 ↑</p> <p>2: 9.4 ↗</p> <p>3: 9.3 →</p> <p>4: 10.7x↑</p> <p>5: 9.7 →</p>		
Serie 46.0			
Total 323.0			

	<p>1: 10.1 ↗</p> <p>2: 9.2 ↓</p> <p>3: 8.8 ↑</p> <p>4: 10.5x ↗</p> <p>5: 9.9 ↖</p> <p>6: 9.4 ↗</p> <p>7: 10.2 ↖</p> <p>8: 8.3 →</p> <p>9: 9.8 ↑</p> <p>10: 9.7 ↓</p>	<p>Prov</p>	<p>11: 10.6x ↗</p> <p>12: 9.4 ↑</p> <p>13: 9.2 ↘</p> <p>14: 10.2 ←</p>
Serie 91.0		Serie 38.0	
Total 183.0		Total 183.0	

<p>1. Serie 10 Skott</p>	<p>1: 10.0 ↘</p> <p>2: 9.8 ←</p> <p>3: 9.3 ↘</p> <p>4: 10.4x →</p> <p>5: 9.7 →</p>		<p>6: 10.0 ↘</p> <p>7: 9.4 ↓</p> <p>8: 10.4x ↘</p> <p>9: 10.4x ↘</p> <p>10: 10.6x ↓</p>
Serie 47.0		Serie 49.0	
Total 230.0		Total 279.0	

<p>2. Serie 1 Skott</p>	<p>1: 10.2 ←</p> <p>2: 10.9x ↘</p> <p>3: 10.7x ↗</p> <p>4: 10.2 ↑</p> <p>5: 8.1 ↖</p>		
Serie 48.0			
Total 327.0			

 <p>Prov</p>	<p>1: 9.4 ↙</p> <p>2: 10.4x➔</p> <p>3: 10.2↙</p> <p>4: 9.8 ↗</p> <p>5: 10.7x➔</p> <p>6: 10.8x↓</p> <p>7: 10.2↙</p> <p>8: 10.4x↑</p> <p>9: 10.7x↘</p> <p>10: 10.1↙</p>	 <p>Prov</p>	<p>11: 10.1↙</p> <p>12: 8.8 ↖</p> <p>13: 9.7 ↗</p> <p>14: 8.7 ↑</p> <p>15: 9.9 ↑</p> <p>16: 10.3↙</p> <p>17: 10.4x↘</p> <p>18: 9.7 ↙</p> <p>19: 9.5 ↙</p> <p>20: 10.2 ↑</p>
Serie 98.0		Serie 92.0	
Total 192.0		Total 192.0	

 <p>Prov</p>	<p>21: 10.7x↗</p> <p>22: 10.6x➔</p> <p>23: 9.5 ↘</p> <p>24: 10.0 ↘</p> <p>25: 10.0↙</p> <p>26: 10.2↑</p> <p>27: 10.0↙</p> <p>28: 10.0↑</p> <p>29: 8.8 ↘</p>	<p>1. Serie 10 Skott</p> 	<p>1: 10.6x➔</p> <p>2: 10.6x➔</p> <p>3: 10.0➔</p> <p>4: 10.2↙</p> <p>5: 9.7 ↘</p>
Serie 87.0		Serie 49.0	
Total 192.0		Total 241.0	

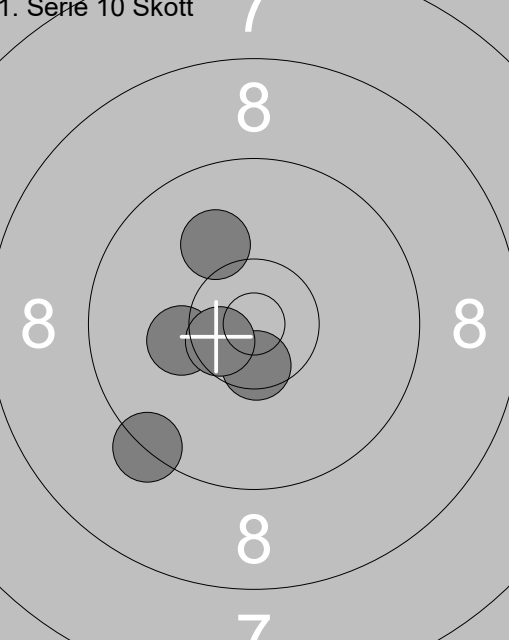
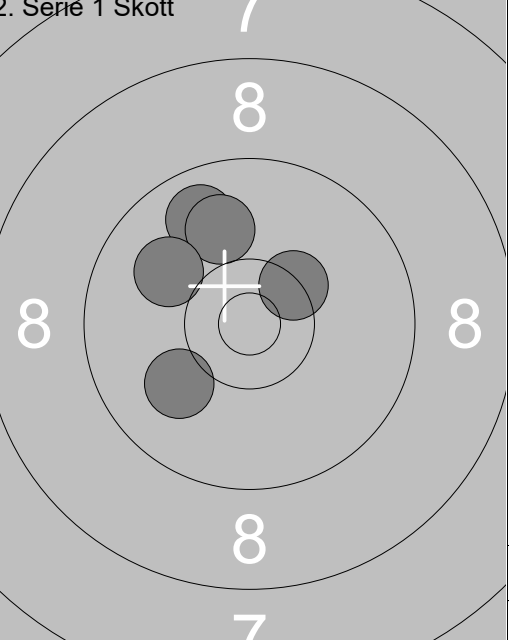
<p>1. Serie 10 Skott</p> 	<p>6: 10.5x↓</p> <p>7: 10.1 ↖</p> <p>8: 10.2↙</p> <p>9: 9.3 ↘</p> <p>10: 10.6x↘</p>	<p>2. Serie 1 Skott</p> 	<p>1: 10.0↙</p> <p>2: 10.4x↗</p> <p>3: 9.8 ↖</p> <p>4: 10.0↑</p> <p>5: 10.0↙</p>
Serie 49.0		Serie 49.0	
Total 290.0		Total 339.0	