

Skjutlag <b>1</b>	Tavla <b>3</b>	<b>Emma Johansson</b>	
Ramselefors	Ramselefors	Öpp	Vb
13.08.2017	SM Banskytte Ställning 2017	Ramselefors SKF	
Prov 4		1: 8.8 ↗ 2: 5.6 ⇒ 3: 8.2 ↑ 4: 10.1 ⇐ 5: 9.7 ↓ Serie 40 Total 0	1. Serie 5 Skott  1: 9.6 ⇒ 2: 10.0 ↓ 3: 10.1 ↓ 4: 8.6 ⇐ 5: 9.3 ↑ Serie 46 Total 46
2. Serie 5 Skott		1: 8.8 ↗ 2: 8.9 ↗ 3: 7.4 ⇐ 4: 10.3 ↓ 5: 10.3 ↓ Serie 43 Total 89	3. Serie 5 Skott  1: 8.4 ⇐ 2: 8.0 ⇐ 3: 6.8 ↓ 4: 10.3 ⇒ 5: 10.6x ↑ Serie 42 Total 131
Prov		1: 8.8 ↓ 2: 10.4 ↑ 3: 9.8 ↓ Serie 27 Total 131	4. Serie 5 Skott  1: 10.3 ↓ 2: 8.1 ↗ 3: 8.5 ⇐ 4: 10.1 ↑ 5: 8.7 ↗ Serie 44 Total 175
5. Serie 5 Skott		1: 8.2 ⇐ 2: 0.0 ⇐ 3: 8.7 ↗ 4: 10.0 ↗ 5: 10.4 ↑ Serie 36 Total 211	

Skjutlag <b>1</b>	Tavla <b>4</b>	<b>Elin Åhlin</b>	
Ramselefors		Bälgviken	Öpp    Sö
13.08.2017		SM Banskytte Ställning 2017	Ramselefors SKF
Prov		1: 10.2 ← 2: 10.5x ↗ 3: 9.4 ↓ 4: 10.1 ↓ 5: 9.2 ↓	1. Serie 5 Skott
		Serie 48 Total 0	1: 10.3 ↑ 2: 10.0 ↘ 3: 10.7x ↑ 4: 9.8 → 5: 10.2 ↓
2. Serie 5 Skott		1: 10.8x ↗ 2: 10.3 → 3: 9.9 → 4: 10.1 ↗ 5: 8.7 ←	3. Serie 5 Skott
		Serie 47 Total 96	1: 9.1 ↗ 2: 10.2 ↗ 3: 9.2 ← 4: 9.4 ↘ 5: 9.0 ↓
Prov		1: 10.5x ↗ 2: 10.7x ↓ 3: 10.2 →	4. Serie 5 Skott
		Serie 30 Total 142	1: 10.0 ↗ 2: 10.0 ↓ 3: 10.4 ↗ 4: 10.0 ← 5: 9.9 ↓
5. Serie 5 Skott		1: 9.9 ↑ 2: 10.3 ↑ 3: 9.3 ↗ 4: 9.6 ↑ 5: 8.9 ↑	
		Serie 45 Total 236	

Skjutlag	Tavla	Casper Fredriksson				
1	5	Ramselefors	Ramselefors	Öpp	Vb	
13.08.2017		SM Banskytte Ställning 2017	Ramselefors SKF			
Prov		1: 9.8 ↗ 2: 10.1 ↘ 3: 10.2 ↘ 4: 10.2 ↘ 5: 10.3 ↘	1. Serie 5 Skott	1: 10.5x ↗ 2: 10.1 → 3: 10.1 ↗ 4: 10.4 → 5: 10.3 ↘	Serie 49 Total 0	Serie 50 Total 50
2. Serie 5 Skott		1: 10.7x ↗ 2: 10.5x → 3: 10.5x ↗ 4: 9.9 ↗ 5: 10.4x →	3. Serie 5 Skott	1: 9.0 ← 2: 9.7 → 3: 9.4 ↘ 4: 7.1 ↗ 5: 9.0 ↗	Serie 49 Total 99	Serie 43 Total 142
Prov		1: 10.4x ↘ 2: 8.8 ↗ 3: 10.0 ←	4. Serie 5 Skott	1: 10.2 ↑ 2: 10.0 ↗ 3: 10.3 ↘ 4: 10.0 ↗ 5: 10.2 →	Serie 28 Total 142	Serie 50 Total 192
5. Serie 5 Skott		1: 10.0 ↘ 2: 9.8 ← 3: 10.1 ↘ 4: 9.7 ← 5: 10.4 →			Serie 48 Total 240	

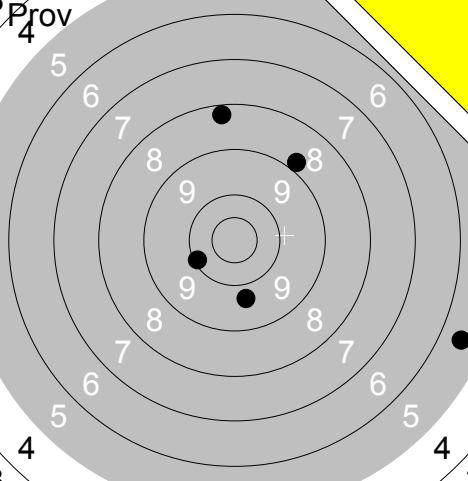
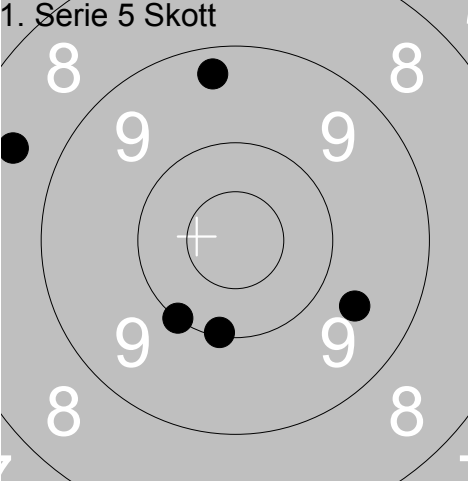
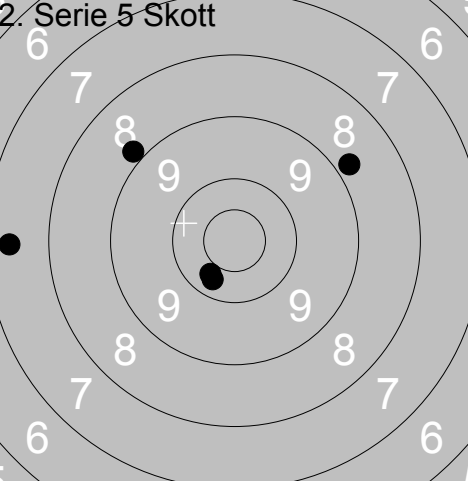
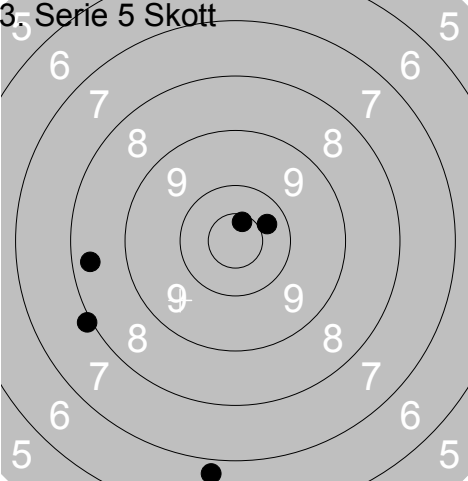
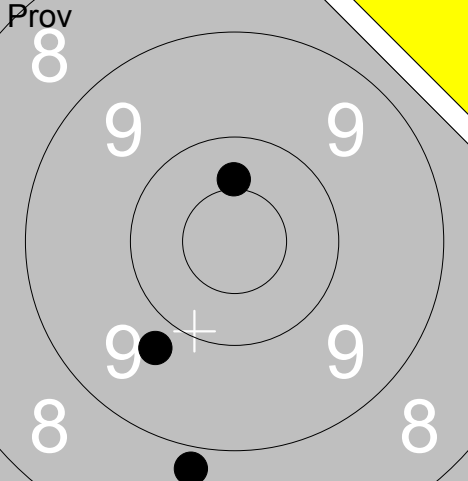
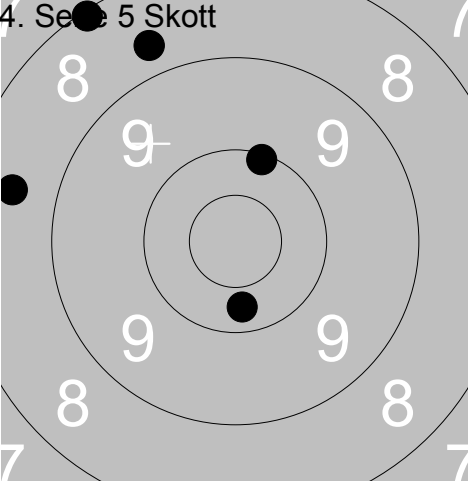
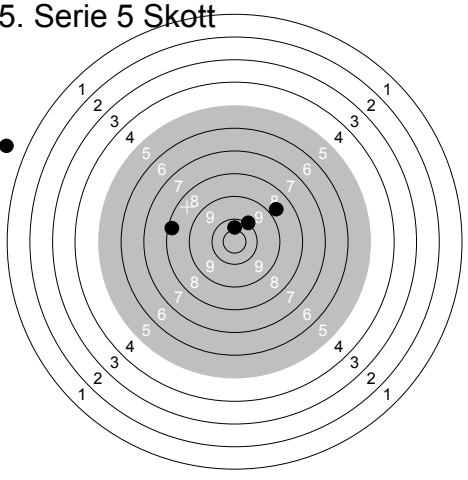
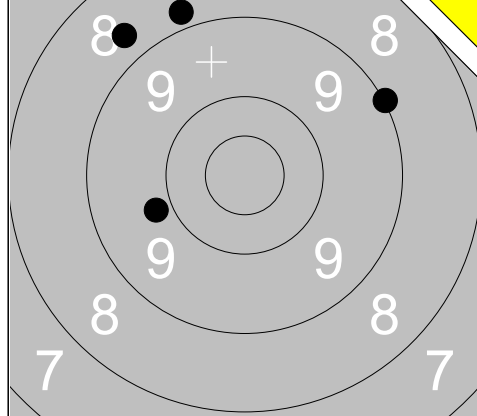

1:	8.8	↗
2:	8.1	↗
3:	9.0	→
4:	9.8	←
5:	8.7	↗
Serie		42
Total		0

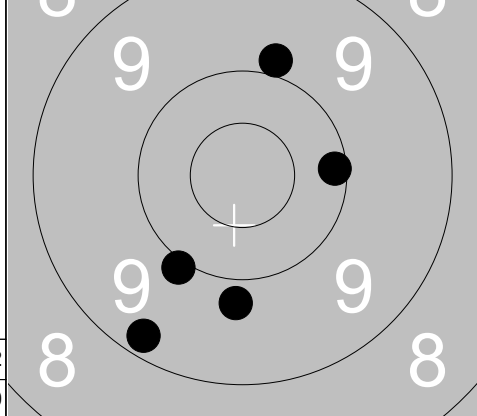

1:	9.8	↓
2:	10.0	↘
3:	10.1	→
4:	9.2	↘
5:	9.9	↗
Serie		47
Total		47

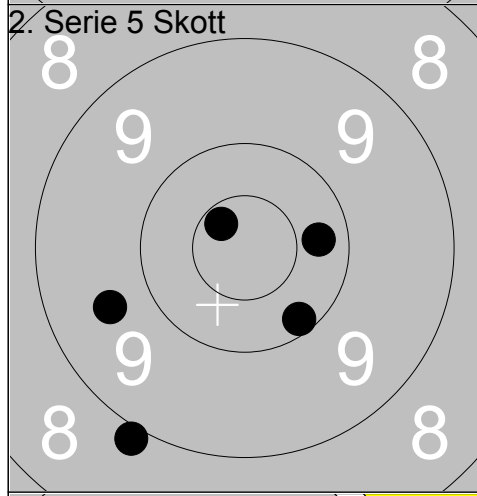

1:	10.3	→
2:	10.2	↘
3:	10.7x	↗
4:	8.9	↘
5:	9.6	←
Serie		47
Total		94

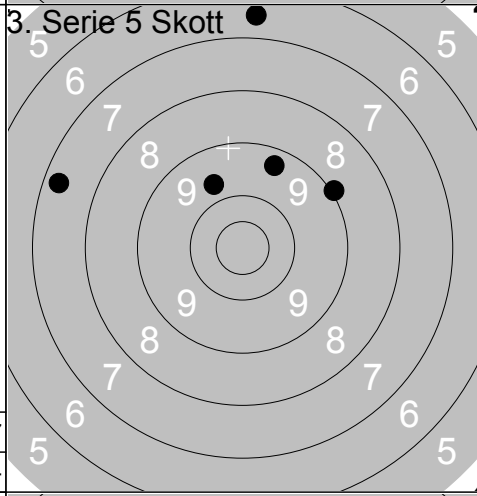

1:	7.3	←
2:	9.7	↗
3:	9.3	↗
4:	6.6	↑
5:	9.0	↗
Serie		40
Total		134

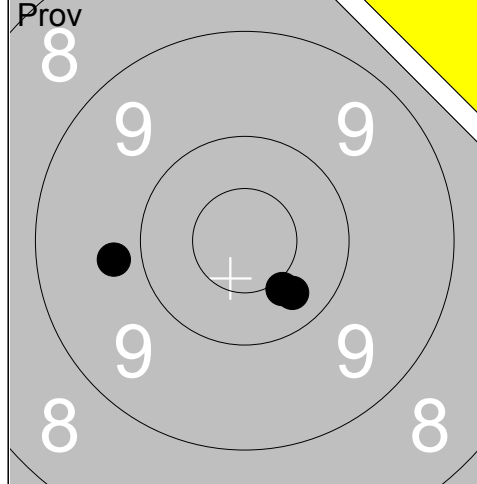

1:	10.3	↘
2:	10.4	↘
3:	9.8	←
Serie		29
Total		134

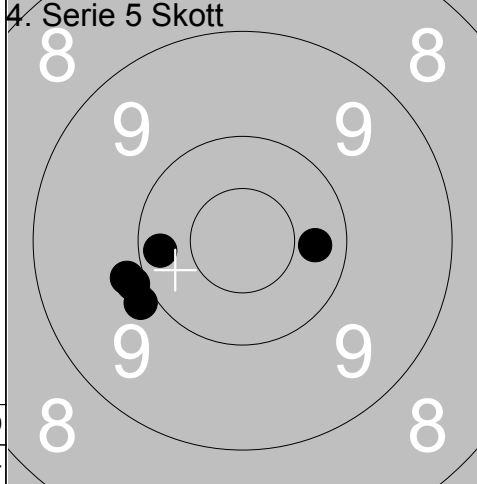

1:	10.3	→
2:	9.9	←
3:	9.9	←
4:	10.2	←
5:	9.9	↙
Serie		47
Total		181

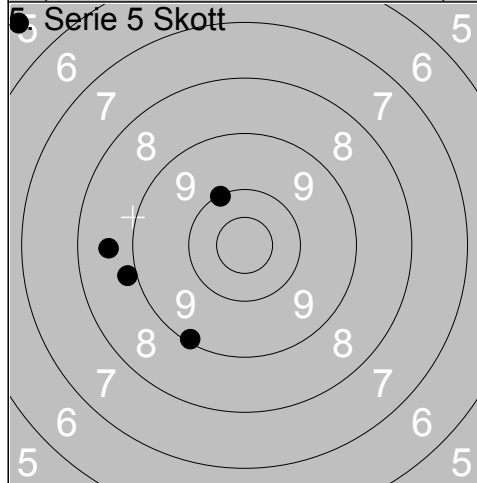

1:	10.0	↗
2:	9.1	↘
3:	8.9	←
4:	8.6	←
5:	5.4	↗
Serie		40
Total		221

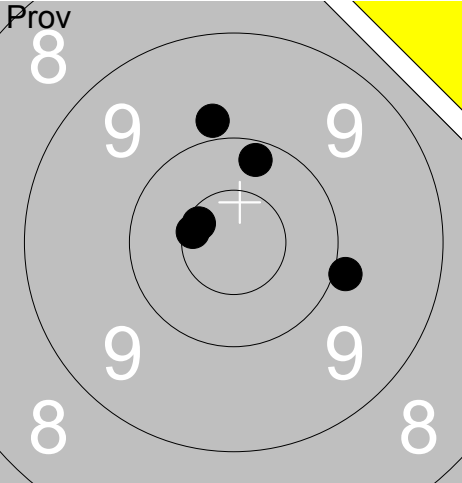
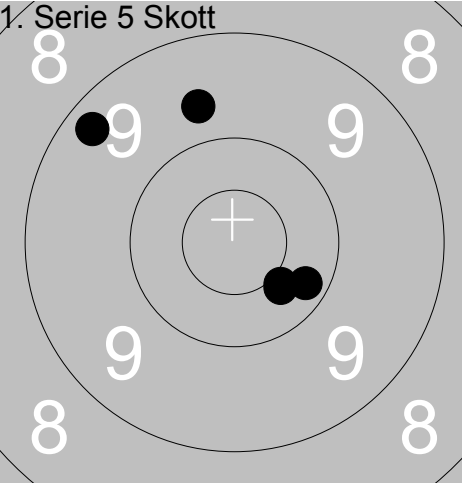
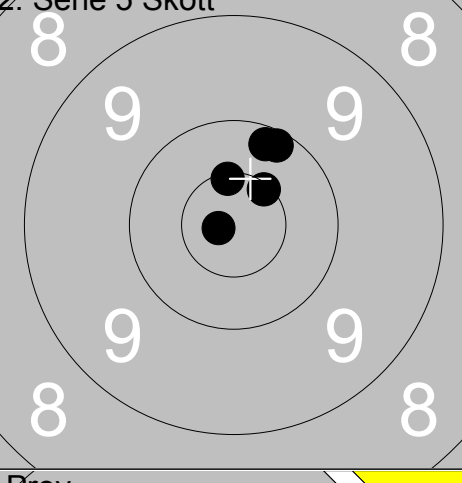
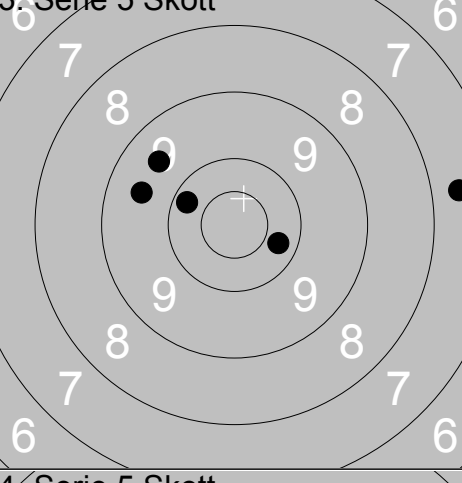
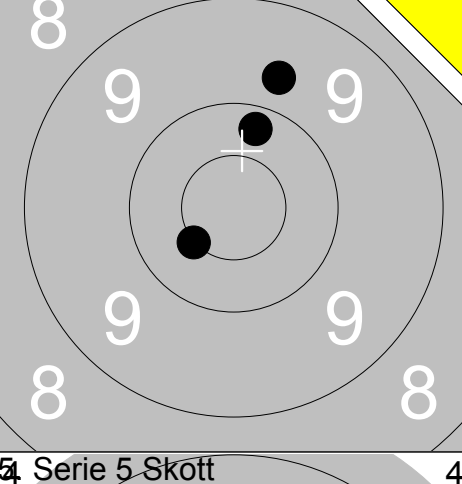
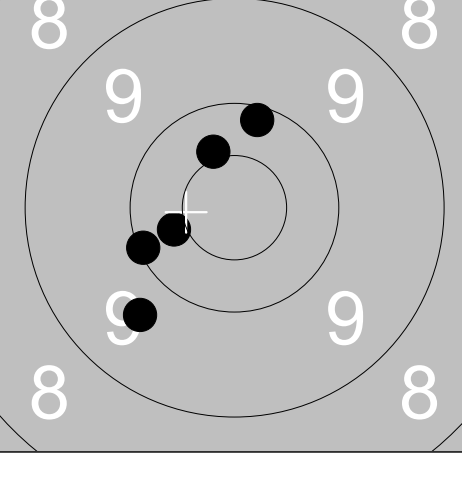
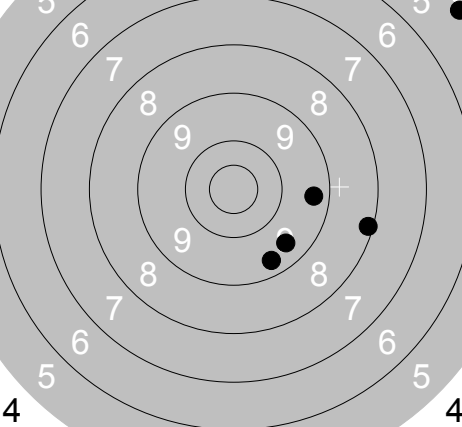
Skjutlag <b>1</b>	Tavla <b>7</b>	<b>Göran Åhlin</b>	
Ramselefors		Bälgviken	Öpp    Sö
13.08.2017		SM Banskytte Ställning 2017	Ramselefors SKF
<b>Prov</b> 	1: 10.6x ← 2: 10.2 ↑ 3: 10.6x ↗ 4: 9.8 ↑ 5: 9.9 →	<b>1. Serie 5 Skott</b> 	1: 9.7 ↑ 2: 9.3 ↗ 3: 10.4 ↘ 4: 10.2 ↘ 5: 10.4 ↘
Serie 48	Total 0	Serie 48	Total 48
<b>2. Serie 5 Skott</b> 	1: 10.5x ↗ 2: 10.2 ↑ 3: 10.2 ↑ 4: 10.5x ↑ 5: 10.8x ←	<b>3. Serie 5 Skott</b> 	1: 9.5 ↗ 2: 9.5 ↗ 3: 10.2 ↗ 4: 7.6 → 5: 10.3 ↘
Serie 50	Total 98	Serie 45	Total 143
<b>Prov</b> 	1: 10.5x ← 2: 10.2 ↑ 3: 9.7 ↑	<b>4. Serie 5 Skott</b> 	1: 10.4x ↑ 2: 10.1 ↑ 3: 10.1 ← 4: 9.7 ↘ 5: 10.4 ←
Serie 29	Total 143	Serie 49	Total 192
<b>4. Serie 5 Skott</b> 	1: 9.4 → 2: 9.5 ↘ 3: 9.4 ↘ 4: 8.1 ↘ 5: 5.0 ↗		
Serie 40	Total 232		

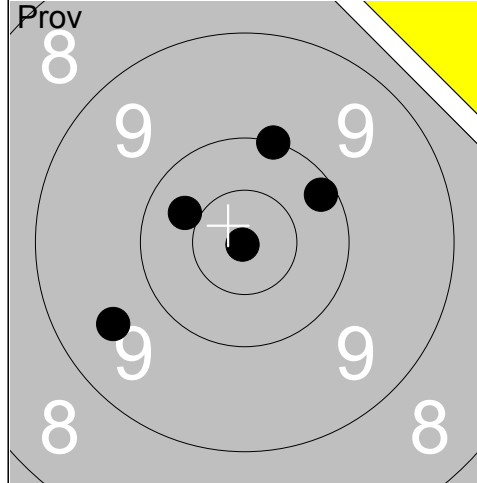

1:	10.2	↗
2:	10.9x	↙
3:	9.6	↙
4:	10.0	↑
5:	10.4	↖
Serie		49
Total		0

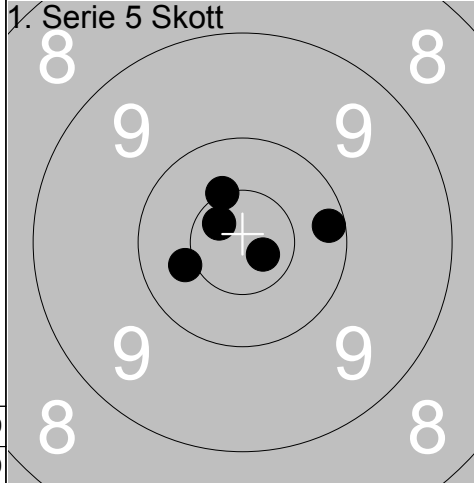

1:	10.2	→
2:	10.5x	↗
3:	10.4	↙
4:	10.7x	↗
5:	10.7x	↘
Serie		50
Total		50

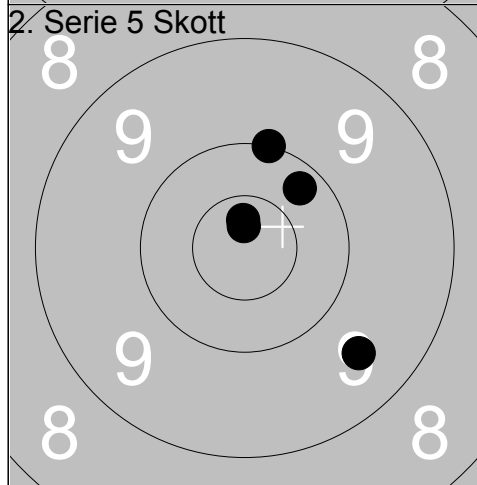

1:	10.0	↑
2:	10.2	↗
3:	9.5	↘
4:	10.8x	↑
5:	10.7x	↑
Serie		49
Total		99

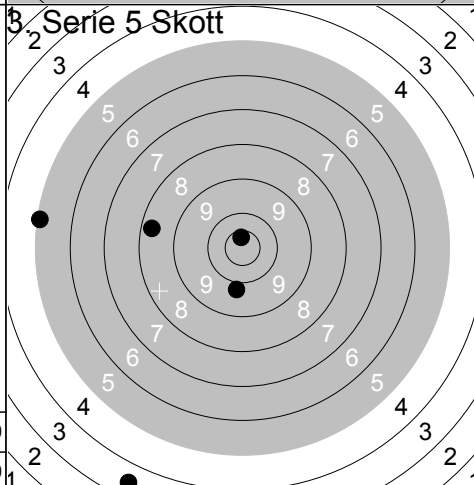

1:	8.3	←
2:	9.8	↓
3:	10.7x	↑
4:	5.1	←
5:	3.5	↓
Serie		35
Total		134

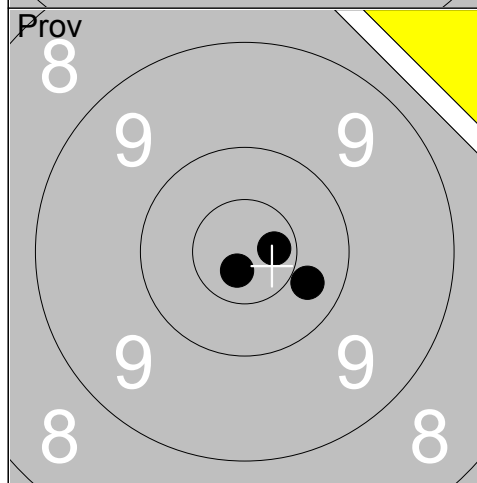

1:	10.7x	→
2:	10.8x	↓
3:	10.3	↘
Serie		30
Total		134

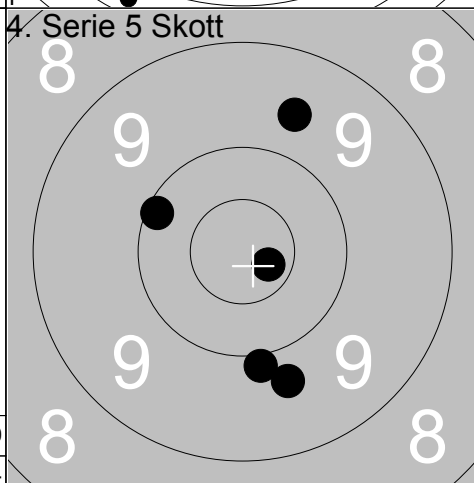

1:	9.9	↓
2:	9.6	↑
3:	10.7x	↘
4:	9.7	↓
5:	10.1	↖
Serie		47
Total		181

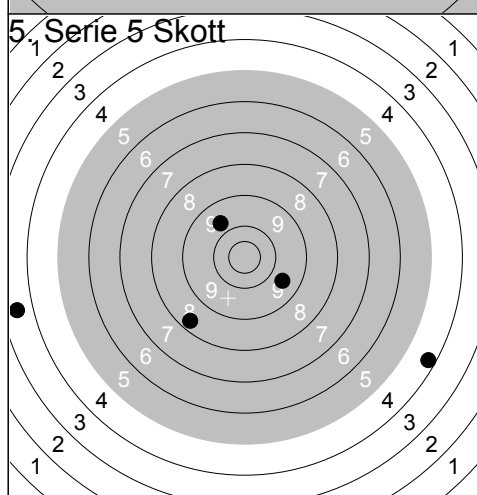

1:	9.6	↘
2:	8.3	↙
3:	9.7	↗
4:	4.3	↘
5:	3.5	←
Serie		33
Total		214

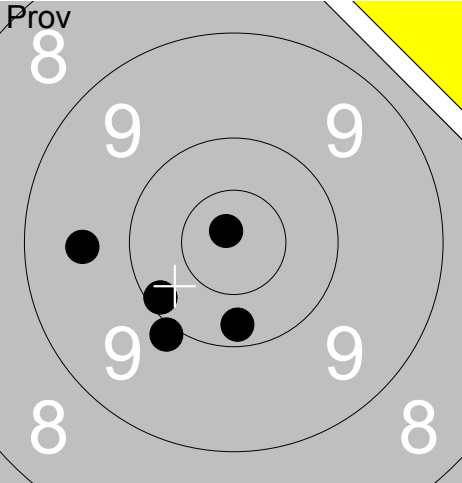
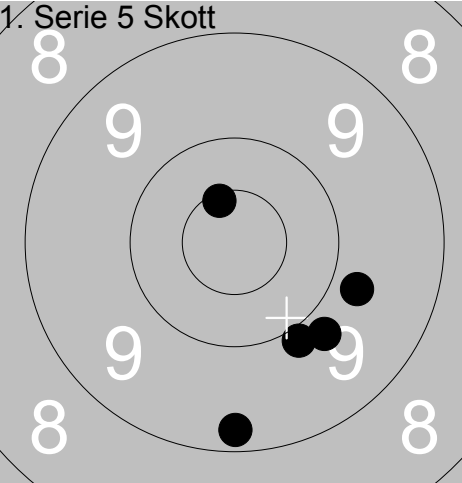
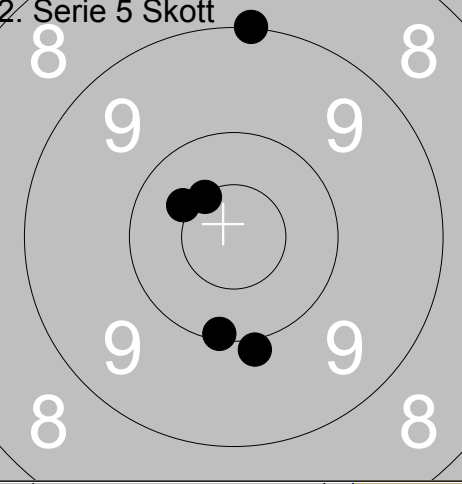
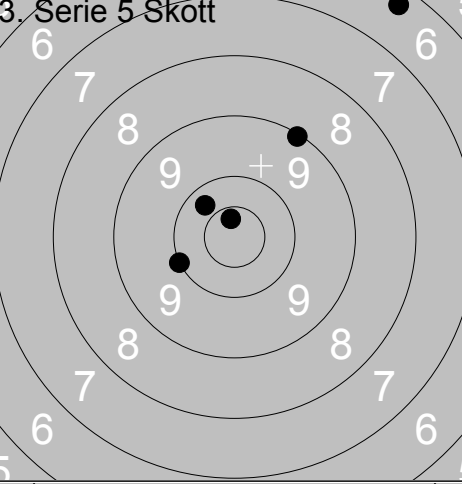
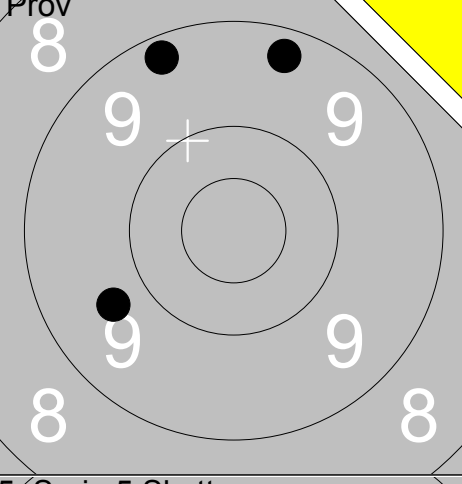
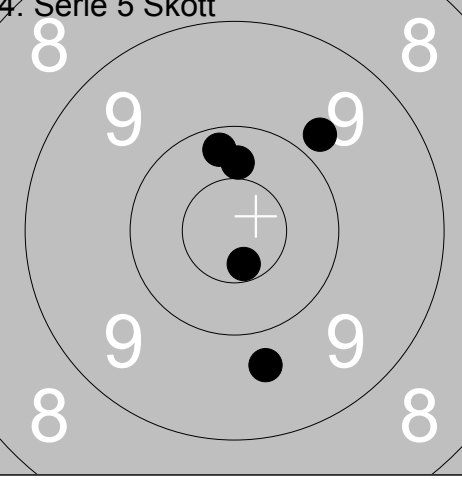
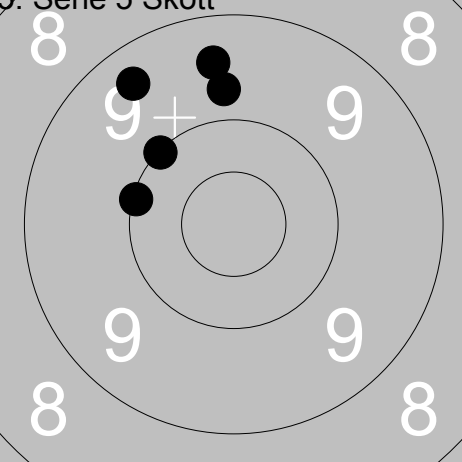
Skjutlag <b>1</b>	Tavla <b>9</b>	<b>Helena Jansson</b>	
Ramselefors	Söderala	Öpp	Gä
13.08.2017	SM Banskytte Ställning 2017	Ramselefors SKF	
<b>Prov</b> 	1: 9.9 ↙ 2: 10.1 ↙ 3: 9.6 ← 4: 10.8x ↗ 5: 10.2 ↓ Serie 48 Total 0	<b>1. Serie 5 Skott</b> 	1: 10.6x ↗ 2: 9.2 ↓ 3: 9.8 ↓ 4: 9.9 ↓ 5: 9.8 ↘ Serie 46 Total 46
<b>2. Serie 5 Skott</b> 	1: 10.1 ↓ 2: 9.9 ↓ 3: 10.5x ↗ 4: 10.4x ↗ 5: 9.0 ↑ Serie 48 Total 94	<b>3. Serie 5 Skott</b> 	1: 10.0 ← 2: 10.7x ↑ 3: 9.1 ↗ 4: 10.3 ↗ 5: 6.3 ↗ Serie 45 Total 139
<b>Prov</b> 	1: 9.3 ↑ 2: 9.7 ← 3: 9.2 ↗ Serie 27 Total 139	<b>4. Serie 5 Skott</b> 	1: 10.6x ↓ 2: 9.7 ↓ 3: 10.2 ↑ 4: 9.8 ↗ 5: 10.3 ↑ Serie 48 Total 187
<b>5. Serie 5 Skott</b> 	1: 9.4 ↗ 2: 10.0 ↗ 3: 10.1 ← 4: 9.5 ↑ 5: 9.7 ↑ Serie 47 Total 234		

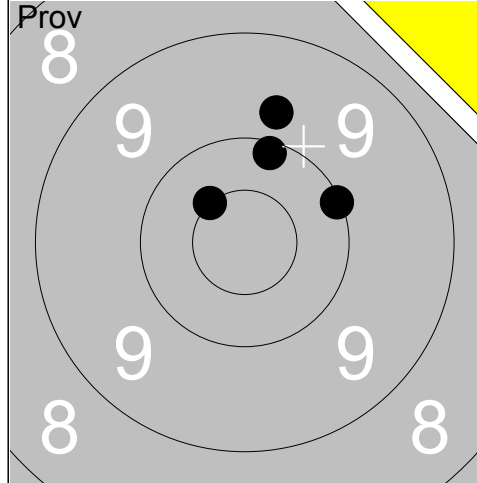

1:	10.1	↑
2:	10.5x	↖
3:	10.1	→
4:	9.8	↑
5:	8.5	↗
Serie		47
Total		0

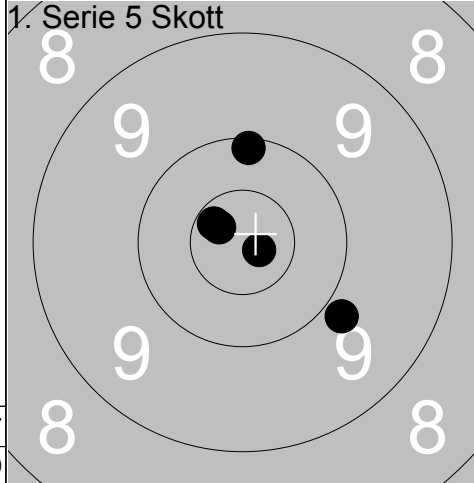

1:	10.6x	↖
2:	10.8x	→
3:	10.1	↑
4:	10.7x	↖
5:	9.8	↘
Serie		49
Total		49

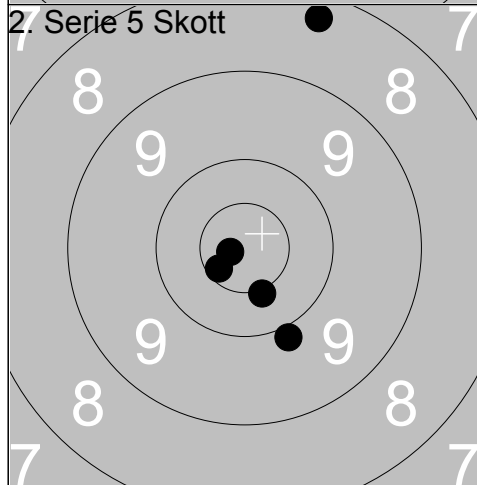

1:	8.3	↑
2:	10.4x	↓
3:	10.6x	↖
4:	9.9	↓
5:	10.8x	←
Serie		47
Total		96

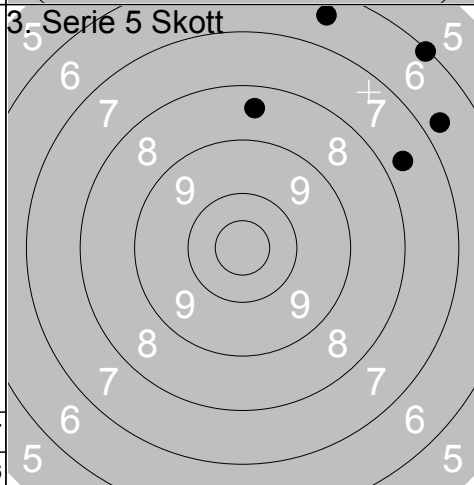

1:	6.5	↑
2:	7.7	↗
3:	8.4	↑
4:	6.7	↗
5:	6.1	↗
Serie		33
Total		129

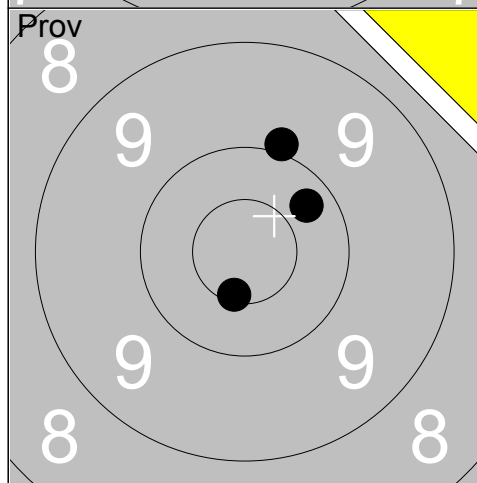

1:	10.3	↗
2:	9.9	↑
3:	10.6x	↓
Serie		29
Total		129

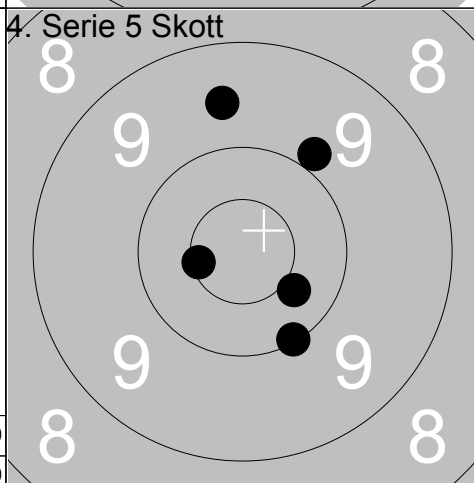

1:	9.9	↗
2:	10.1	↓
3:	10.4	↘
4:	9.6	↑
5:	10.5x	←
Serie		48
Total		177

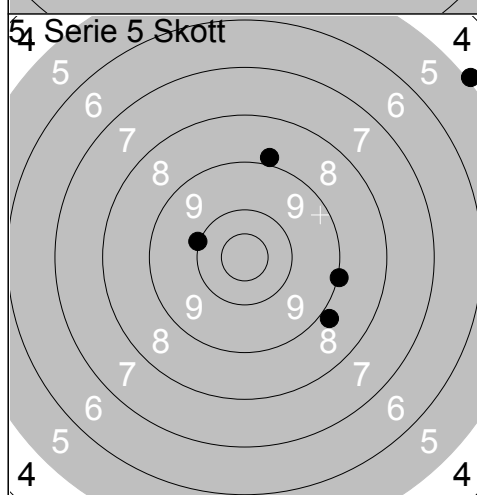

1:	8.9	↑
2:	9.0	→
3:	10.0	↖
4:	4.9	↗
5:	8.8	↘
Serie		39
Total		216

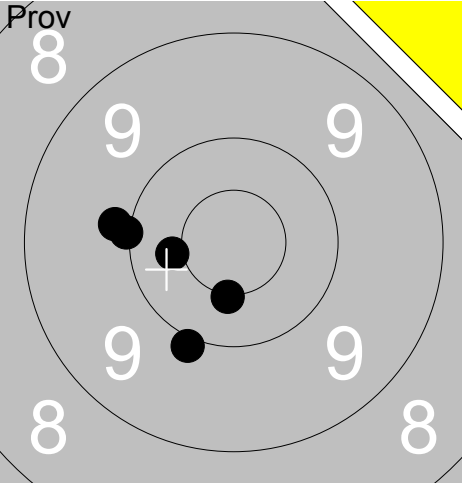
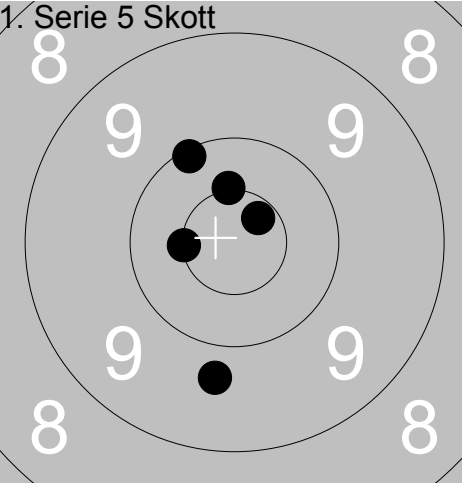
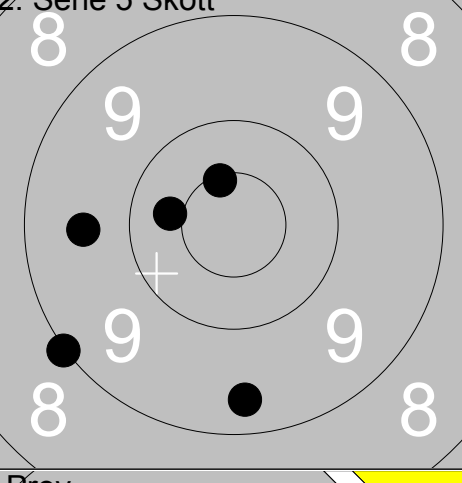
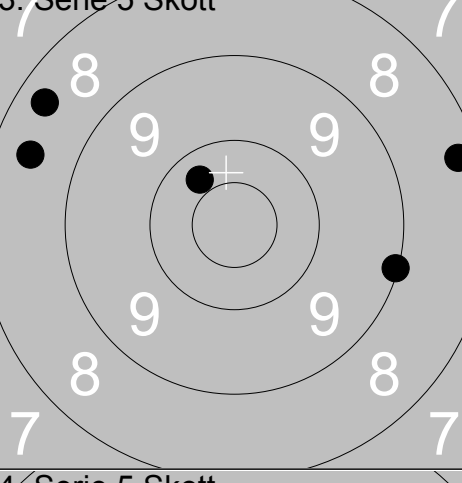
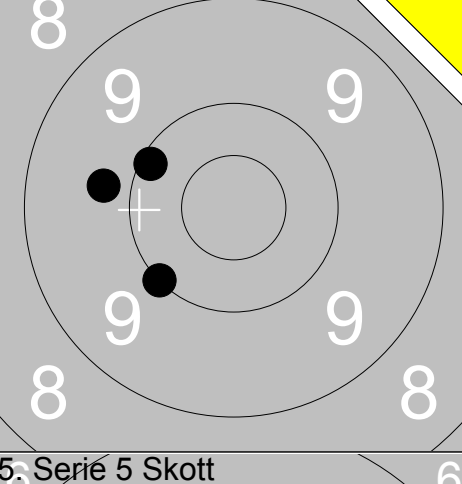
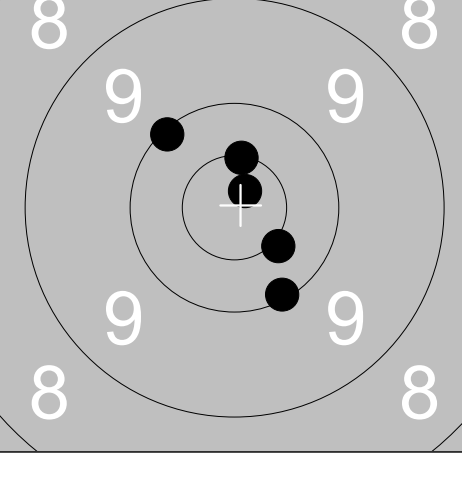
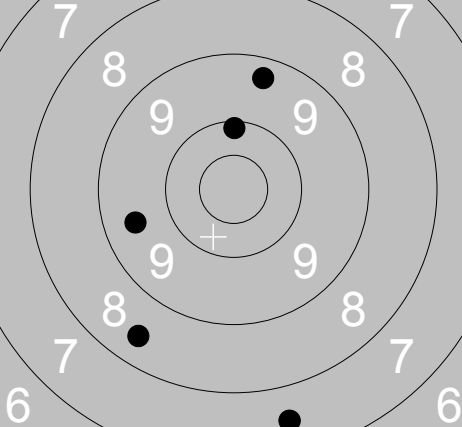

Skjutlag	Tavla	Skjutare		Öpp	Sö
1	11	Marcus Åhlin			
Ramselefors		Bälgviken			
13.08.2017		SM Banskytte Ställning 2017		Ramselefors SKF	
Prov		1: 10.5x ↓ 2: 10.0 ← 3: 9.9 ← 4: 10.4 ← 5: 9.9 ↓		1. Serie 5 Skott 1: 10.1 ↗ 2: 10.5x ↑ 3: 10.7x ↗ 4: 9.7 ↓ 5: 10.5x ←	
		Serie 48	Total 0	Serie 49	Total 49
2. Serie 5 Skott		1: 10.5x ↑ 2: 9.4 ↓ 3: 10.4 ← 4: 9.6 ← 5: 9.0 ↙		3. Serie 5 Skott 1: 8.5 ← 2: 10.3 ↗ 3: 8.4 ↗ 4: 9.1 → 5: 8.3 →	
		Serie 47	Total 96	Serie 43	Total 139
Prov		1: 10.1 ← 2: 9.8 ← 3: 10.0 ↙		4. Serie 5 Skott 1: 10.5x ↑ 2: 10.8x ↗ 3: 10.1 ↓ 4: 10.4x ↓ 5: 10.1 ↗	
		Serie 29	Total 139	Serie 50	Total 189
5. Serie 5 Skott		1: 10.1 ↑ 2: 9.5 ← 3: 9.3 ↑ 4: 8.5 ↙ 5: 7.5 ↓			
		Serie 43	Total 232		

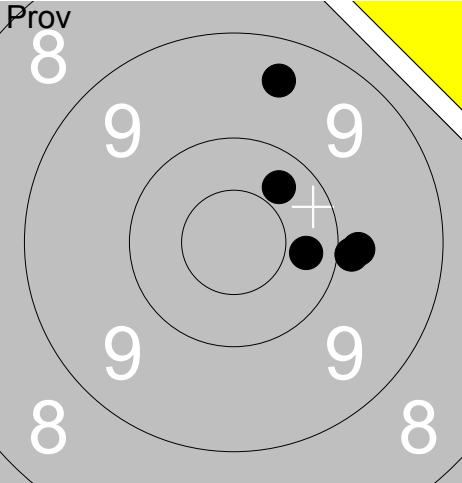
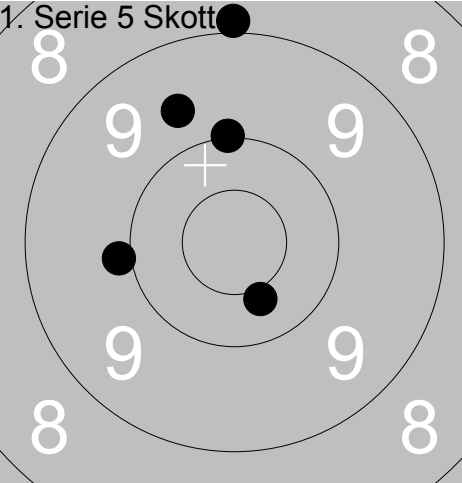
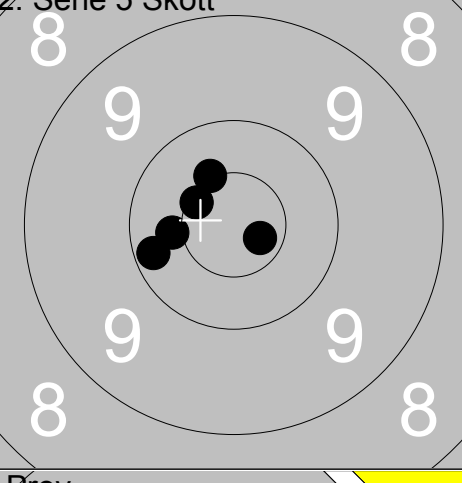
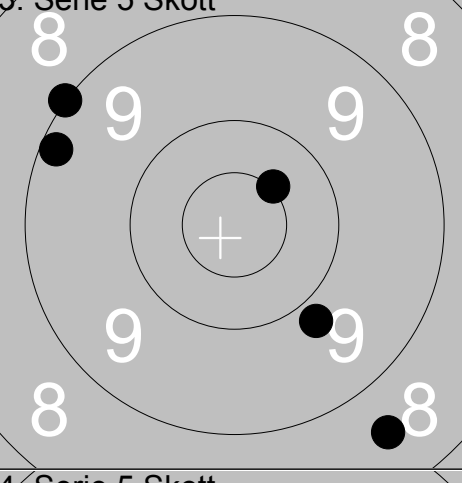
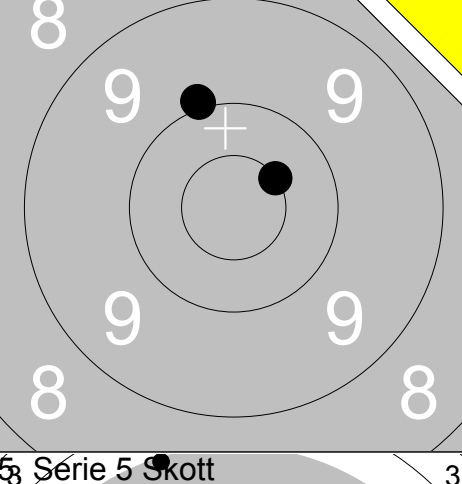
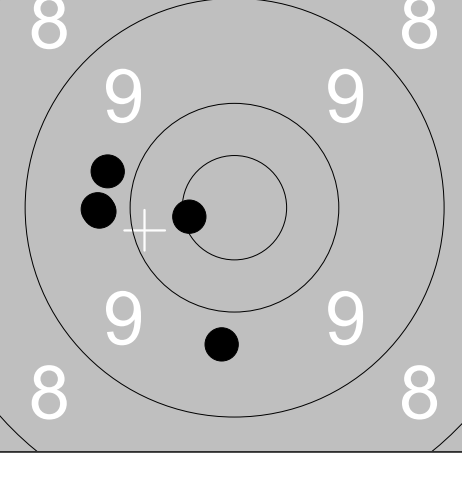
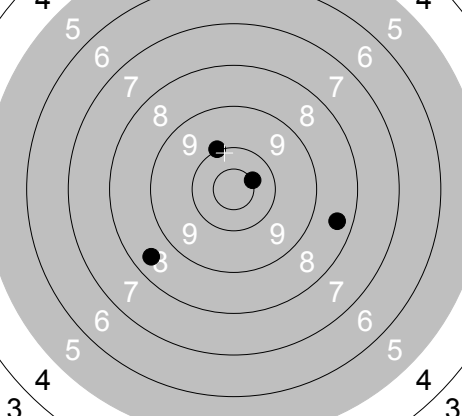
Skjutlag <b>1</b>	Tavla <b>12</b>	<b>Markus Andersson</b>			
Ramselefors		Bälinge-Jumkil		Öpp	Up
13.08.2017		SM Banskytte Ställning 2017		Ramselefors SKF	
<b>Prov</b> 		1: 10.3 → 2: 9.9 → 3: 9.8 → 4: 9.4 ↑ 5: 10.3 ↗	<b>1. Serie 5 Skott</b> 	1: 9.9 ← 2: 8.9 ↑ 3: 9.7 ↗ 4: 10.0 ↑ 5: 10.4 ↓	
Serie 47		Total 0	Serie 46		Total 46
<b>2. Serie 5 Skott</b> 		1: 10.5x ↗ 2: 10.2 ← 3: 10.7x → 4: 10.6x ↗ 5: 10.4 ←	<b>3. Serie 5 Skott</b> 	1: 9.2 ← 2: 10.5x ↗ 3: 9.0 ↗ 4: 9.8 ↓ 5: 8.6 ↓	
Serie 50		Total 96	Serie 45		Total 141
<b>Prov</b> 		1: 10.5x ↗ 2: 10.0 ↑ 3: 10.0 ↑	<b>4. Serie 5 Skott</b> 	1: 9.7 ↓ 2: 9.7 ← 3: 9.7 ← 4: 10.5x ← 5: 9.8 ←	
Serie 30		Total 141	Serie 46		Total 187
<b>5. Serie 5 Skott</b> 		1: 8.5 ← 2: 10.5x ↗ 3: 10.0 ↑ 4: 8.4 ↘ 5: 5.1 ↗			
Serie 41		Total 228			

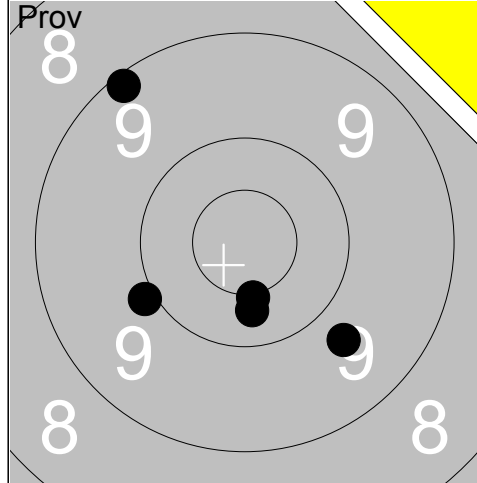

1:	9.1	↗
2:	10.5x	↓
3:	9.9	←
4:	9.7	↓
5:	10.3	↓
Serie		47
Total		0

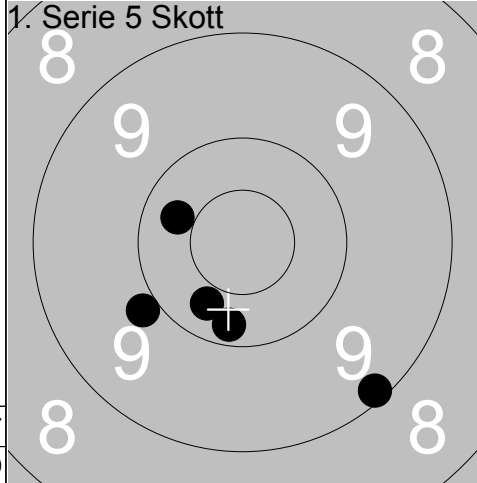

1:	9.9	↙
2:	10.3	↓
3:	10.2	↓
4:	9.1	↓
5:	10.3	↖
Serie		48
Total		48

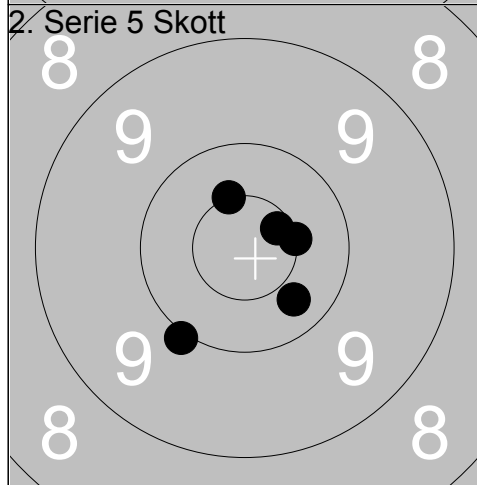

1:	10.3	↘
2:	10.5x	→
3:	10.5x	↗
4:	10.0	↓
5:	10.6x	→
Serie		50
Total		98

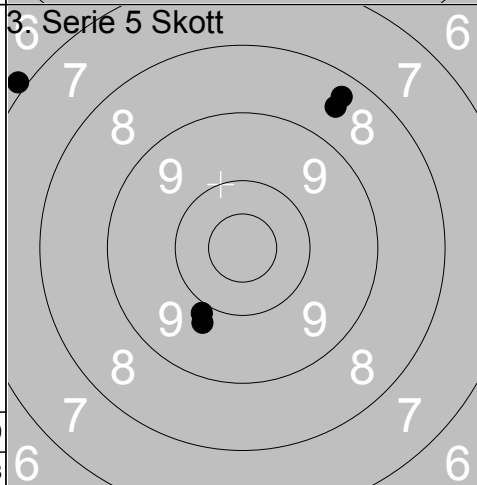

1:	8.4	↗
2:	9.8	↓
3:	9.9	↓
4:	6.9	↖
5:	8.5	↗
Serie		40
Total		138

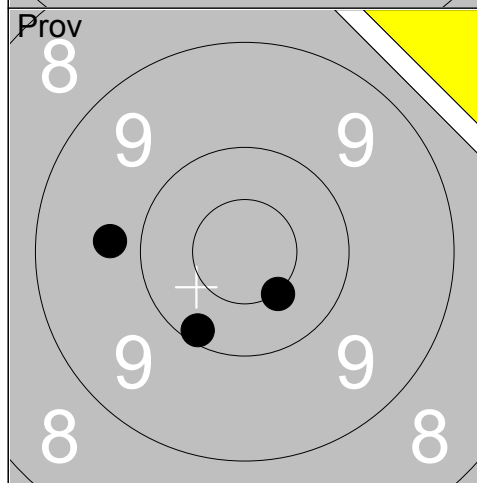

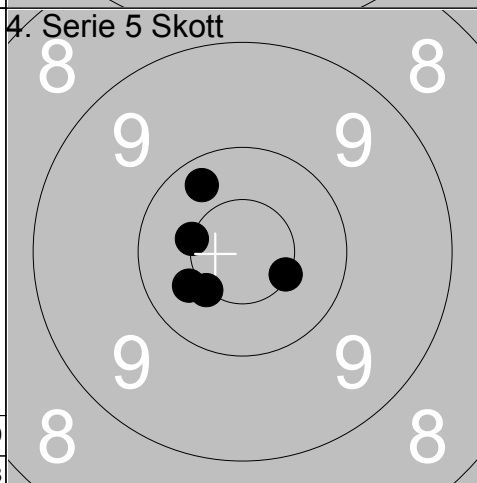

1:	9.7	←
2:	10.5x	↓
3:	10.1	↓
Serie		29
Total		138

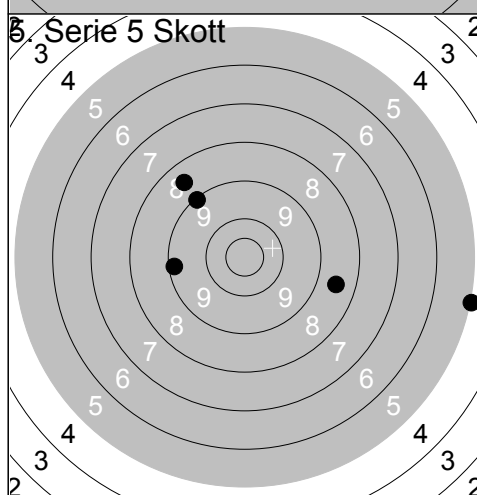

1:	10.5x	↙
2:	10.5x	↙
3:	10.4	↙
4:	10.5x	→
5:	10.3	↗
Serie		50
Total		188

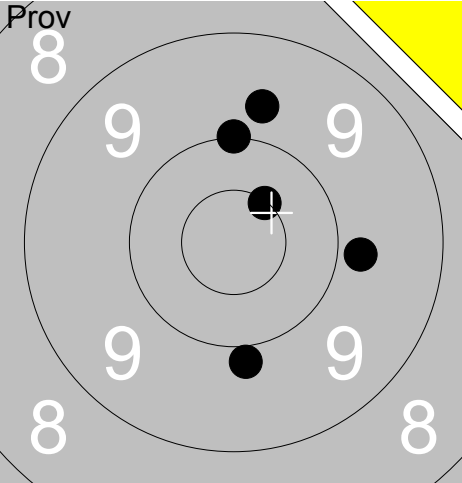
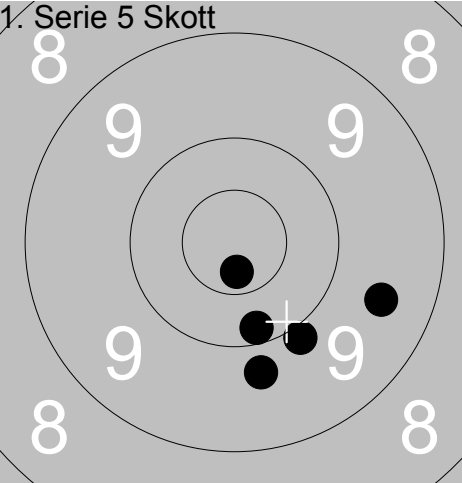
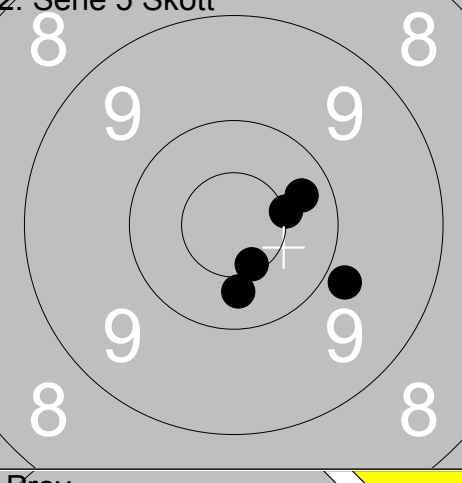
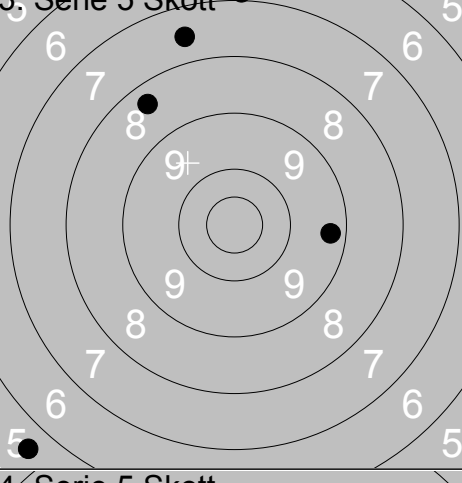

1:	9.1	↗
2:	9.2	←
3:	8.5	→
4:	8.5	↗
5:	5.0	↓
Serie		39
Total		227

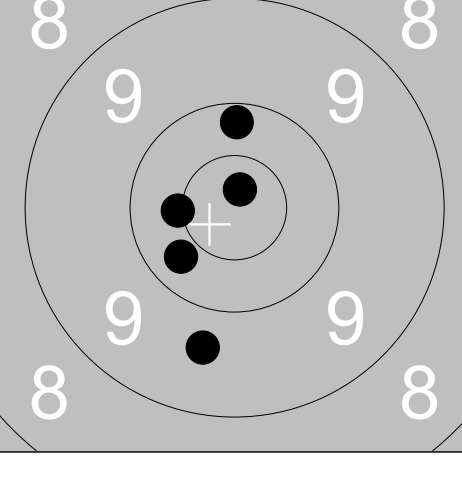
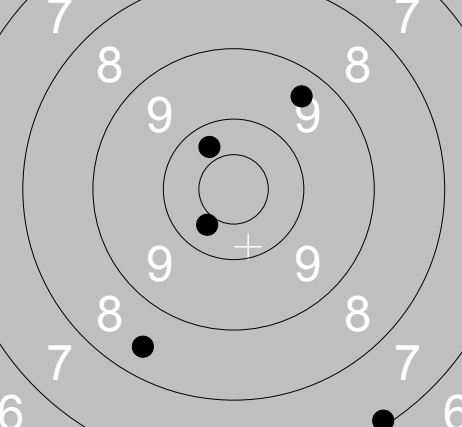
Skjutlag	Tavla	Stefan Burchardt		
1	14	Ramselefors	Söderala	Öpp
13.08.2017		SM Banskytte Ställning 2017	Ramselefors SKF	Gä
<b>Prov</b> 	1: 9.7 ↑ 2: 9.8 → 3: 10.5x ↗ 4: 10.0 ↑ 5: 9.9 ↓	<b>1. Serie 5 Skott</b> 	1: 10.7x ↓ 2: 9.8 ↓ 3: 9.9 ↓ 4: 9.5 → 5: 10.2 ↓	
	Serie 47 Total 0		Serie 47 Total 47	
<b>2. Serie 5 Skott</b> 	1: 10.4 ↓ 2: 10.3 → 3: 10.5x → 4: 10.6x ↓ 5: 9.8 →	<b>3. Serie 5 Skott</b> 	1: 6.9 ↑ 2: 7.6 ↑ 3: 8.4 ↗ 4: 5.6 ↓ 5: 9.3 →	
	Serie 49 Total 96		Serie 35 Total 131	
<b>Prov</b> 	1: 10.7x ↑ 2: 10.0 ↗ 3: 10.4 ↗	<b>4. Serie 5 Skott</b> 	1: 10.2 ↑ 2: 10.4x ← 3: 10.8x ↑ 4: 10.3 ↙ 5: 9.7 ↓	
	Serie 30 Total 131		Serie 49 Total 180	
<b>5. Serie 5 Skott</b> 	1: 10.4 ↙ 2: 9.4 ↗ 3: 10.3 ↗ 4: 8.4 ↓ 5: 7.1 ↓			
	Serie 44 Total 224			

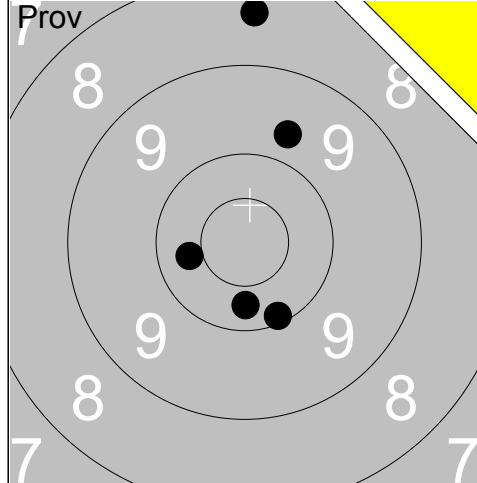

1:	8.4	↑
2:	10.4	←
3:	10.3	↓
4:	10.1	↓
5:	9.7	↑
Serie		47
Total		0

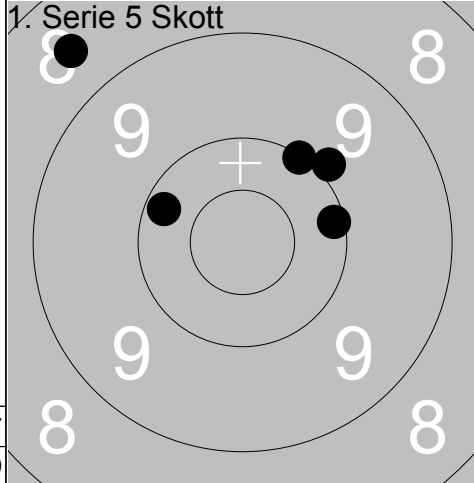

1:	8.6	↖
2:	10.2	↖
3:	10.1	→
4:	9.9	↗
5:	10.1	↗
Serie		47
Total		47

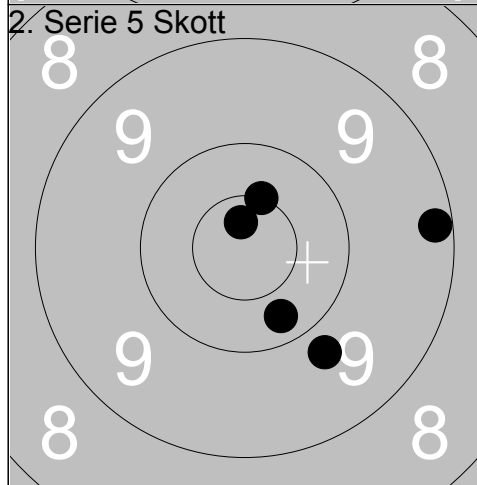

1:	10.5x	↑
2:	9.8	↘
3:	9.2	→
4:	10.3	↘
5:	10.7x	↑
Serie		48
Total		95

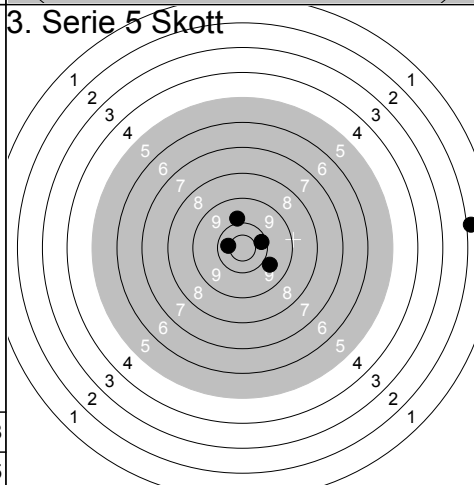

1:	1.9	→
2:	10.2	→
3:	9.8	↑
4:	10.4	←
5:	9.8	↘
Serie		39
Total		134

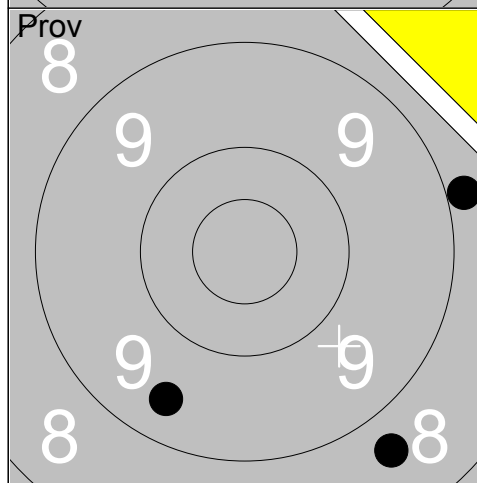

1:	9.4	↘
2:	8.7	↘
3:	8.9	→
Serie		25
Total		134

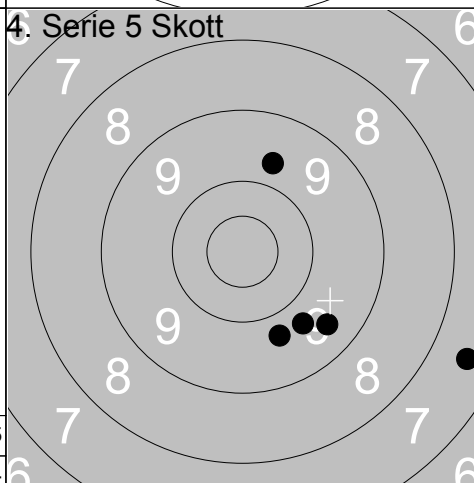

1:	9.7	↘
2:	7.5	→
3:	9.7	↘
4:	9.4	↘
5:	9.7	↑
Serie		43
Total		177

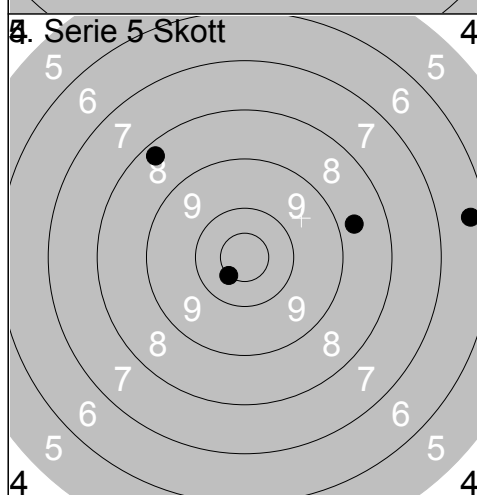

1:	6.3	→
2:	8.7	→
3:	10.5x	↖
4:	8.3	↖
5:	0.0	
Serie		32
Total		209

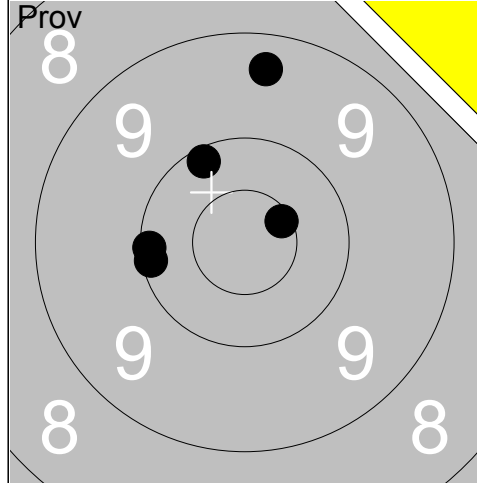

1:	10.1	←
2:	10.1	←
3:	10.1	↗
4:	9.4	↑
5:	10.6x	↘
Serie		49
Total		0

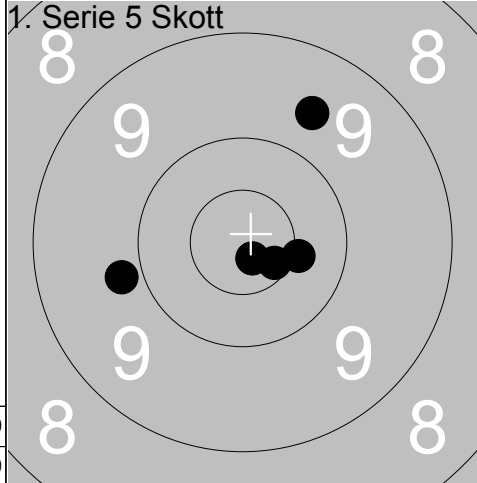

1:	10.8x	↘
2:	9.6	↗
3:	10.4x	→
4:	10.6x	↘
5:	9.8	←
Serie		48
Total		48

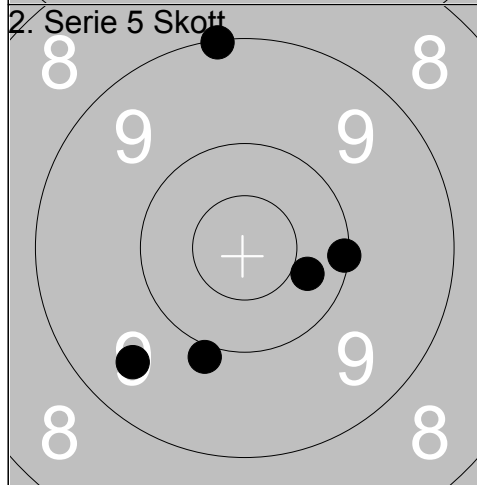

1:	10.3	→
2:	9.9	↘
3:	9.5	↘
4:	10.1	→
5:	9.0	↑
Serie		47
Total		95

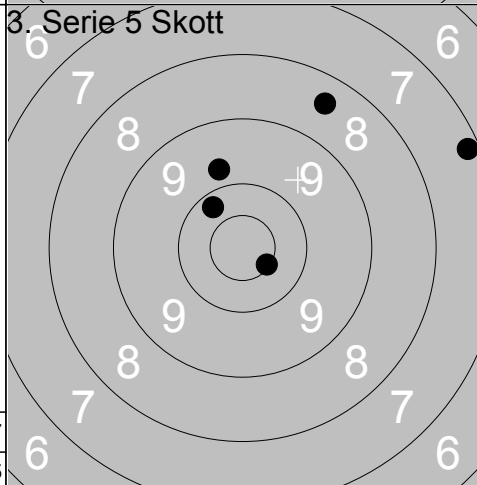

1:	9.8	↗
2:	10.5x	↘
3:	10.2	↗
4:	7.2	→
5:	8.5	↗
Serie		44
Total		139

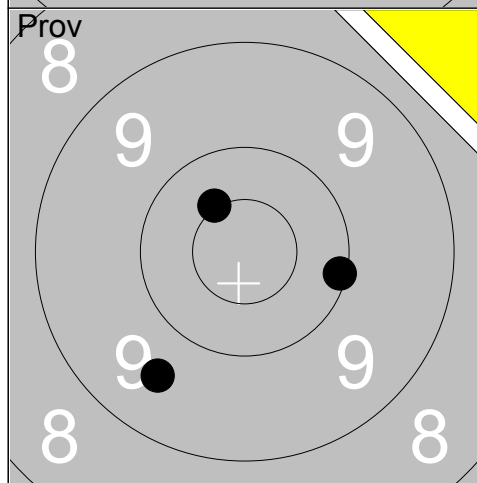

1:	10.1	→
2:	10.5x	↗
3:	9.6	↘
Serie		29
Total		139

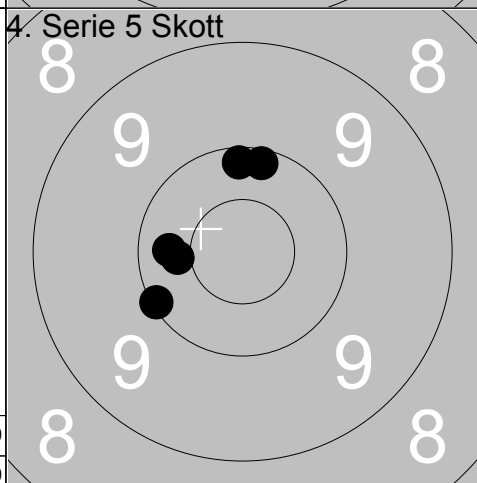

1:	10.2	↑
2:	10.4	←
3:	10.2	↑
4:	10.3	←
5:	10.1	↙
Serie		50
Total		189

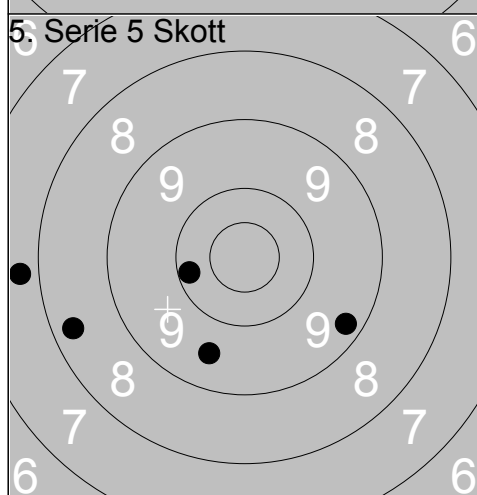

1:	10.2	←
2:	9.3	↘
3:	9.5	↘
4:	8.3	←
5:	7.8	←
Serie		43
Total		232

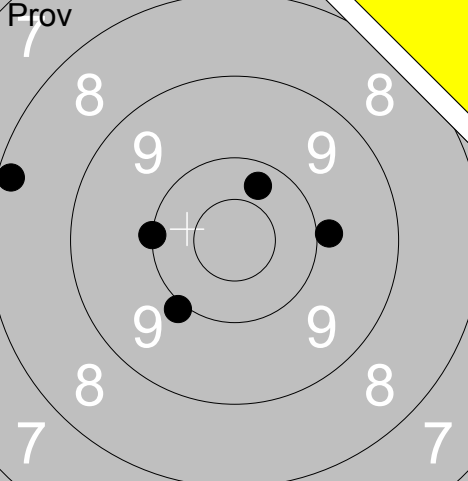
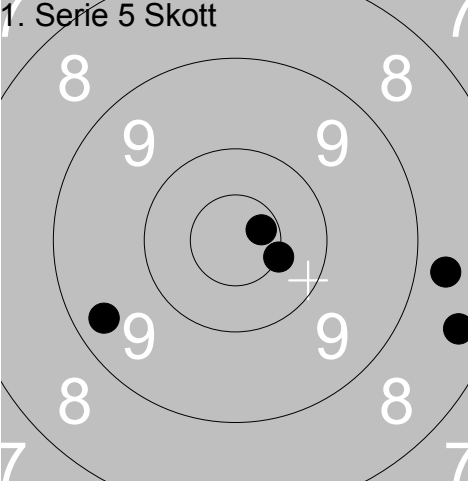
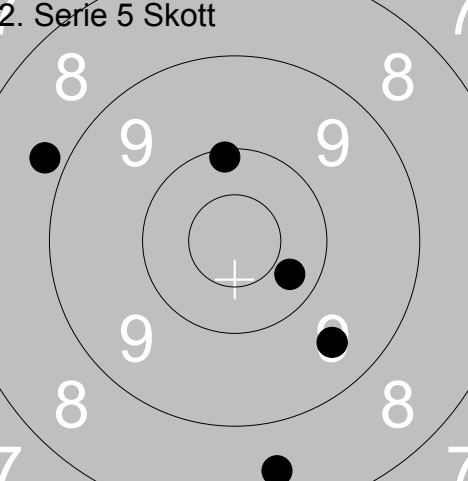
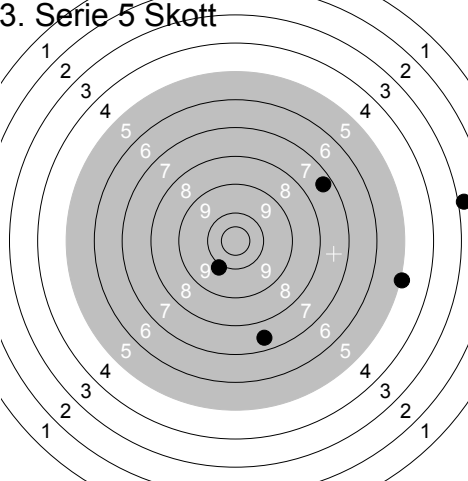
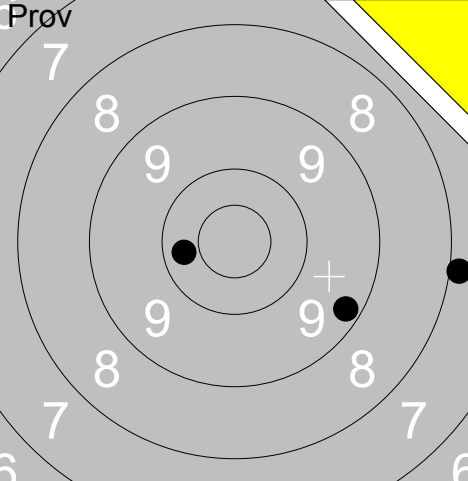
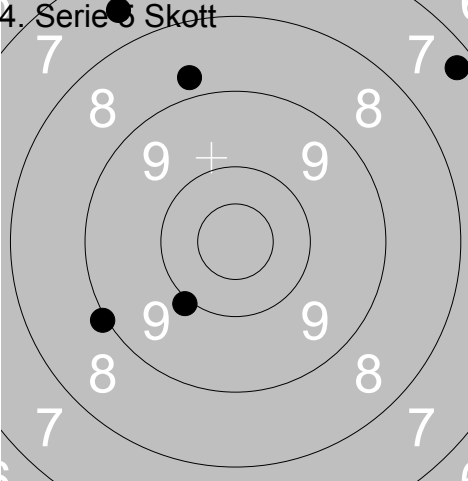
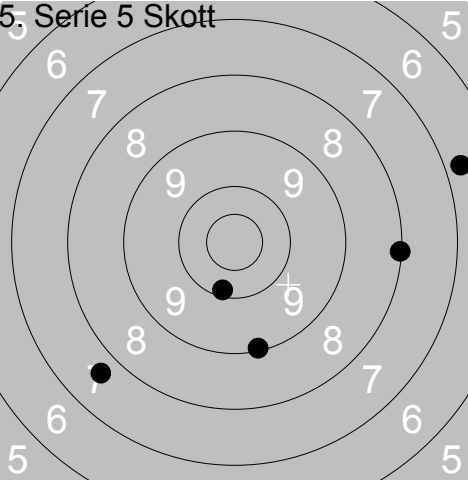
Skjutlag <b>1</b>	Tavla <b>17</b>	<b>Mattias Nordlander</b>	
Ramselefors	KA 2	Öpp	Bl
13.08.2017	SM Banskytte Ställning 2017	Ramselefors SKF	
Prov 	1: 9.9 → 2: 8.2 ← 3: 10.0 ← 4: 9.9 ↙ 5: 10.3 ↗	1. Serie 5 Skott 	1: 9.4 ↙ 2: 8.4 → 3: 10.5x → 4: 8.7 → 5: 10.7x →
	Serie 46 Total 0		Serie 45 Total 45
2. Serie 5 Skott 	1: 8.8 ← 2: 8.5 ↘ 3: 10.1 ↗ 4: 9.5 ↘ 5: 10.3 ↘	3. Serie 5 Skott 	1: 9.9 ↙ 2: 7.3 ↗ 3: 2.8 → 4: 5.0 → 5: 7.5 ↘
	Serie 45 Total 90		Serie 30 Total 120
Prov 	1: 7.9 → 2: 10.3 ← 3: 9.2 ↘	4. Serie 5 Skott 	1: 7.6 ↖ 2: 9.0 ← 3: 7.3 ↗ 4: 8.8 ↗ 5: 10.0 ↙
	Serie 26 Total 120		Serie 41 Total 161
5. Serie 5 Skott 	1: 8.1 → 2: 9.1 ↘ 3: 10.1 ↘ 4: 7.7 ↙ 5: 6.8 →		
	Serie 40 Total 201		

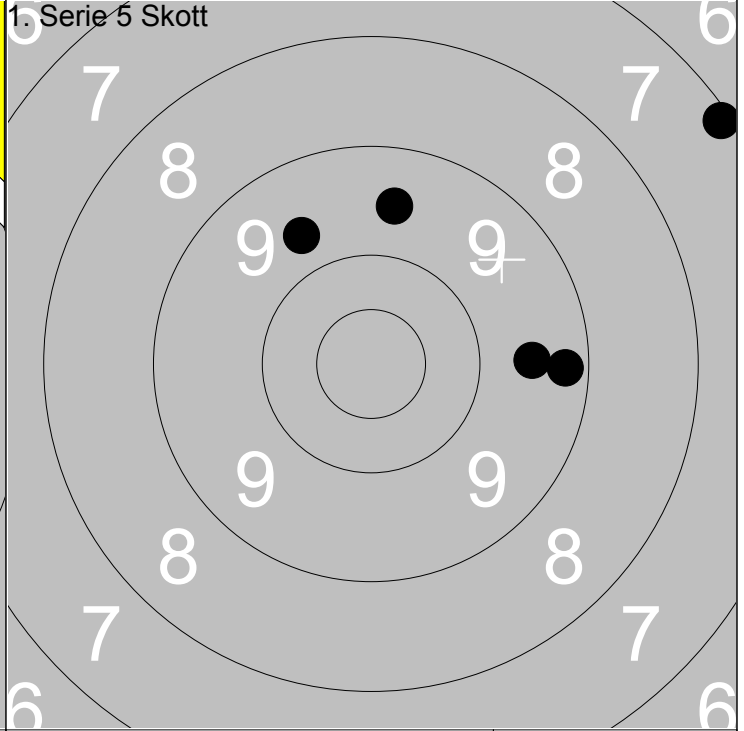
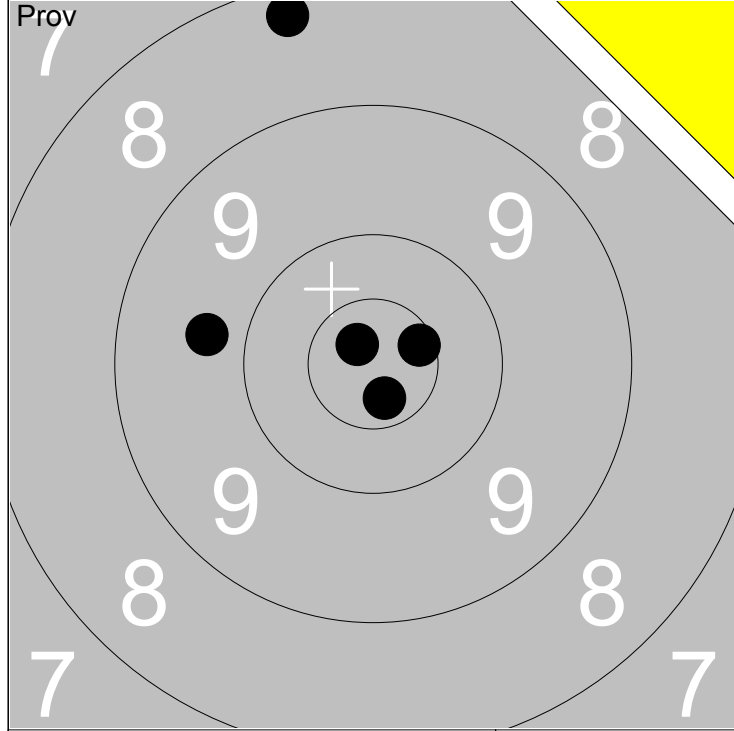

1: 8.3	↗
2: 10.8x	↖
3: 10.6x	→
4: 9.7	←
5: 10.7x	↘

Serie	47
Total	0

1: 9.6	→
2: 9.2	→
3: 7.1	↗
4: 9.6	↑
5: 9.7	↖

Serie	43
Total	43

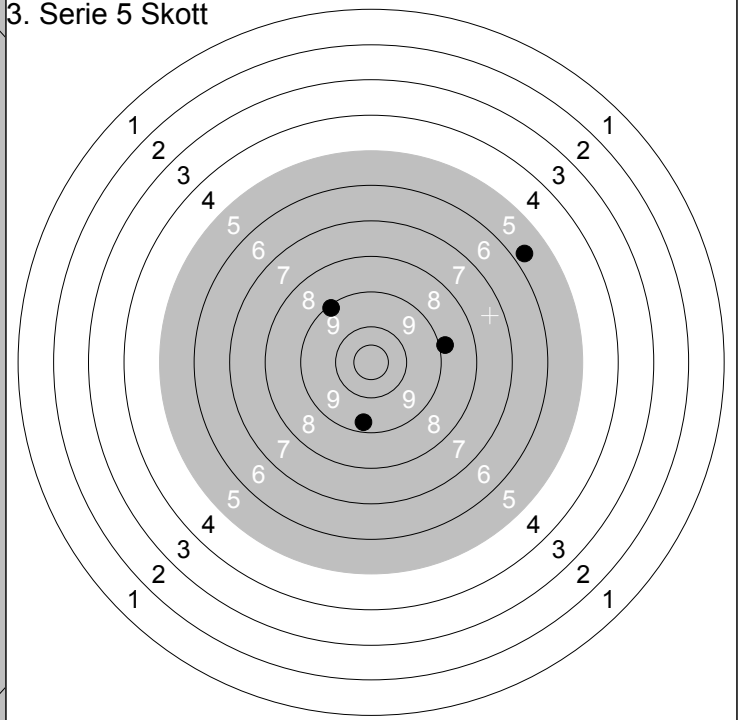
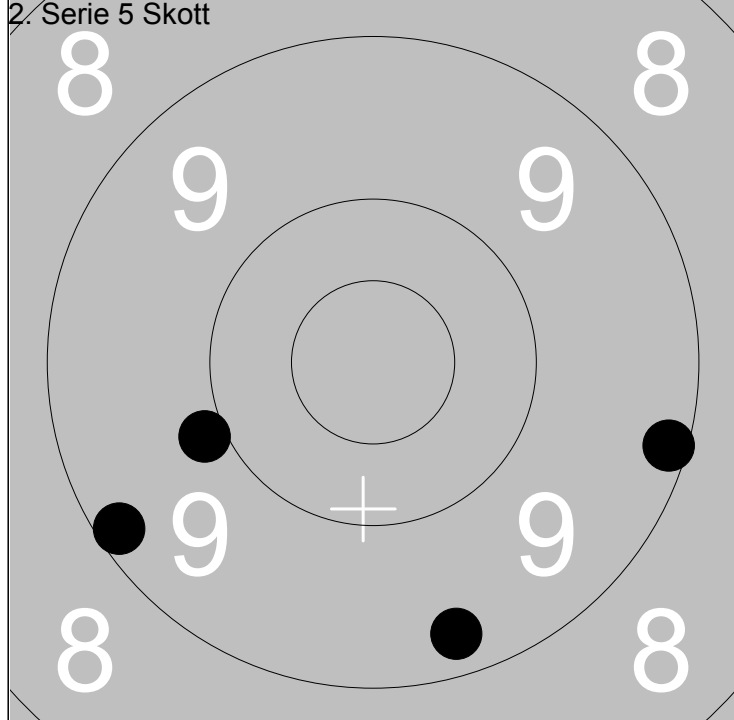

1: 9.1	→
2: 9.9	←
3: 9.3	↘
4: 9.2	↖
5: 0.0	

Serie	36
Total	79

1: 8.9	→
2: 9.3	↘
3: 9.1	↖
4: 0.0	→
5: 5.7	↗

Serie	31
Total	110



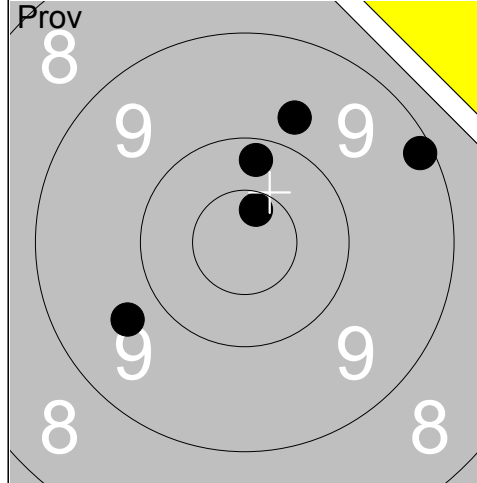

1:	10.6x	↑
2:	9.7	↑
3:	10.2	↑
4:	9.7	↙
5:	9.1	➔
Serie		47
Total		0

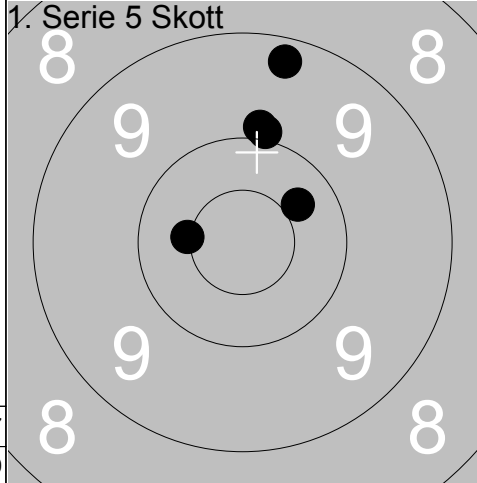

1:	10.0	↑
2:	10.4	➔
3:	10.5x	↙
4:	9.3	↑
5:	9.9	↑
Serie		48
Total		48

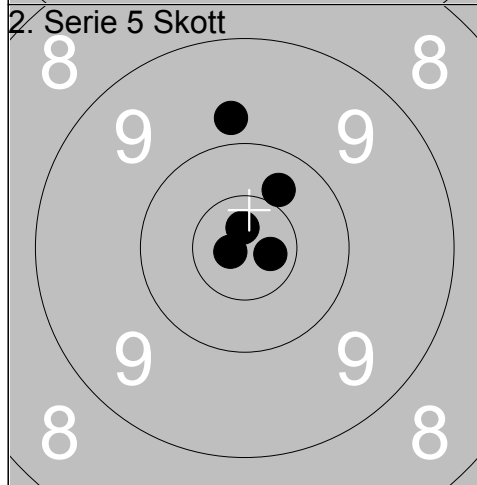

1:	10.8x	↙
2:	10.8x	↑
3:	10.7x	➔
4:	10.4	↗
5:	9.8	↑
Serie		49
Total		97

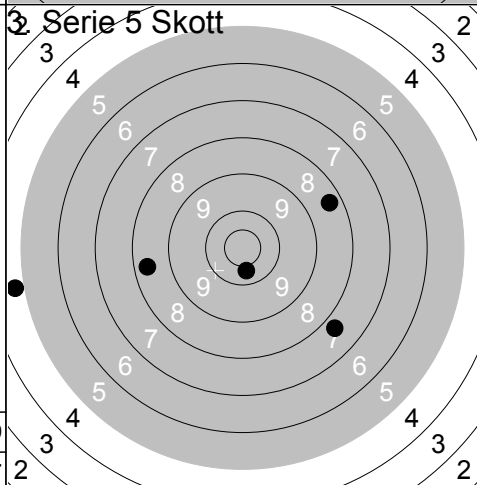

1:	8.4	➔
2:	10.4	↓
3:	8.4	↙
4:	7.7	↘
5:	4.8	↙
Serie		37
Total		134

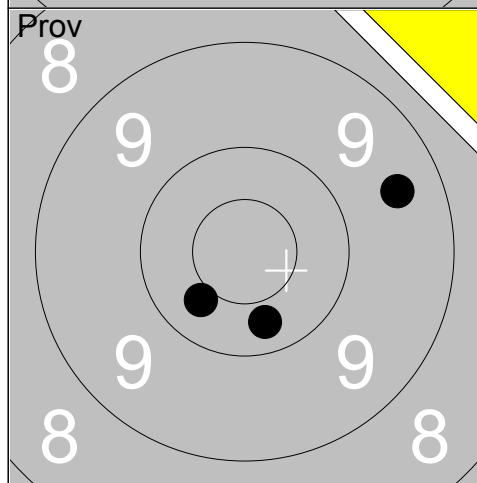

1:	10.4	↙
2:	10.3	↓
3:	9.5	➔
Serie		29
Total		134

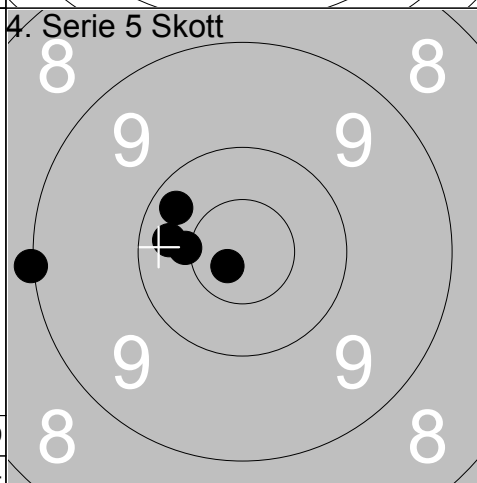

1:	9.0	↙
2:	10.3	↙
3:	10.8x	↙
4:	10.4x	↙
5:	10.2	↗
Serie		49
Total		183

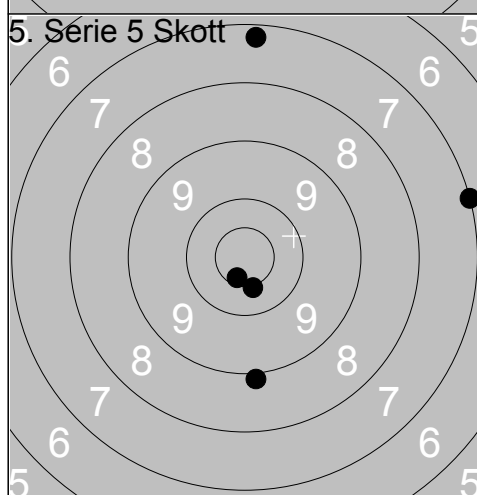

1:	8.9	↓
2:	10.5x	↓
3:	10.6x	↓
4:	7.0	➔
5:	7.2	↑
Serie		42
Total		225

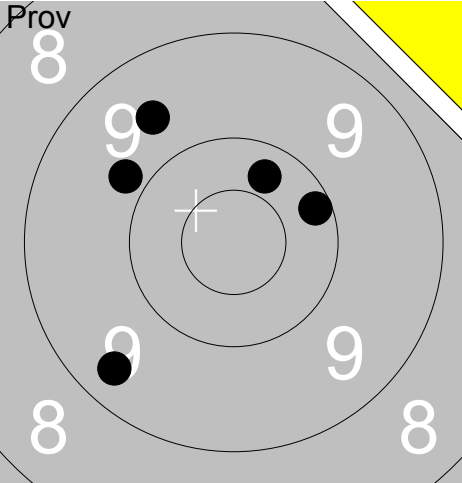
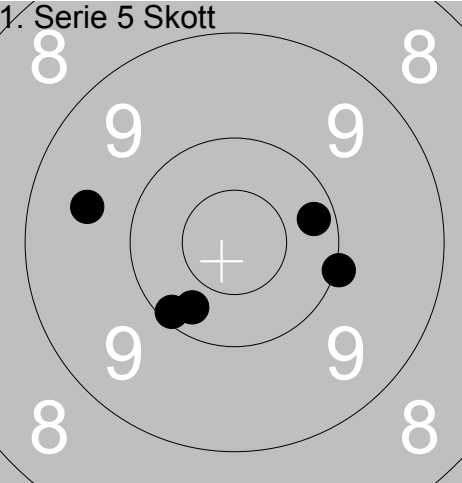
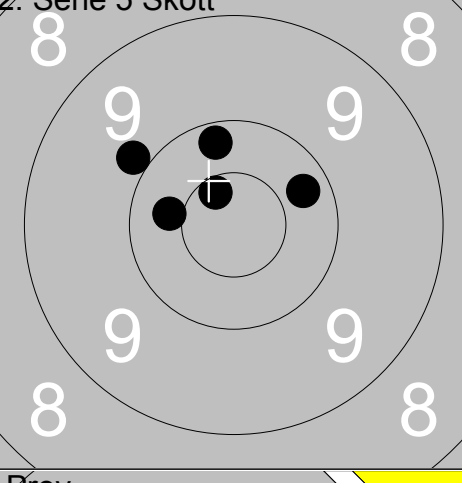
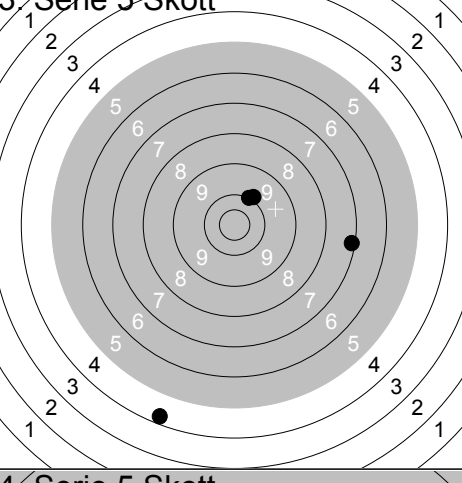
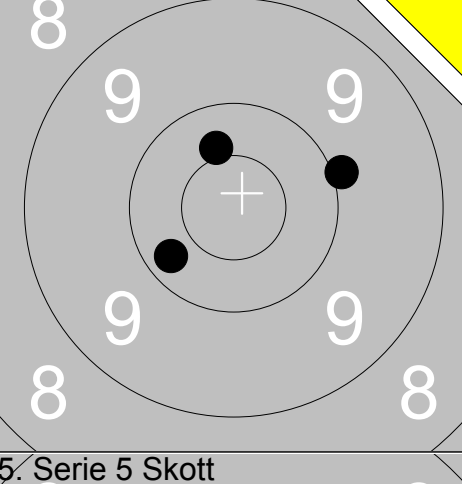
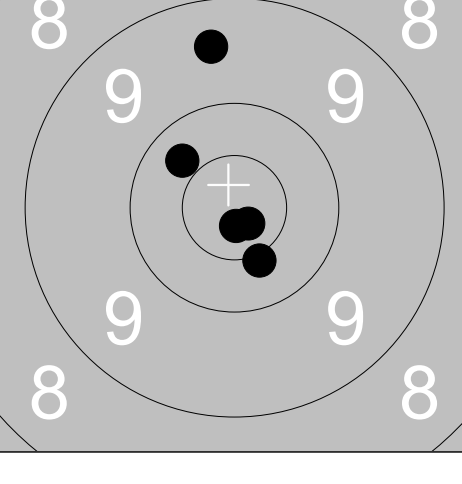
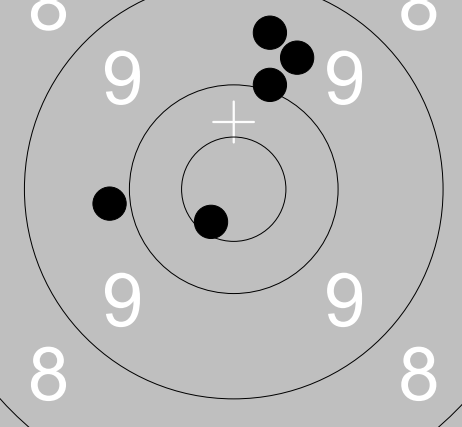
Skjutlag <b>1</b>	Tavla <b>20</b>	<b>Urban Johansson</b>	
Ramselefors	F 21	Öpp	No
13.08.2017	SM Banskytte Ställning 2017	Ramselefors SKF	
Prov		1: 9.4 ↙ 2: 9.6 ↗ 3: 10.2 → 4: 10.3 ↗ 5: 9.8 ↗	1. Serie 5 Skott 
	Serie 47 Total 0		1: 10.0 → 2: 10.2 → 3: 10.3 ↙ 4: 10.1 ↙ 5: 9.6 ←
			Serie 49 Total 49
2. Serie 5 Skott		1: 10.3 → 2: 10.4 ← 3: 10.2 ↗ 4: 10.6x ↗ 5: 9.9 ↗	3. Serie 5 Skott 
	Serie 49 Total 98		1: 7.1 → 2: 10.0 ↗ 3: 9.9 ↗ 4: 2.2 ↗ 5: 4.3 ↘
			Serie 32 Total 130
Prov		1: 10.4 ↗ 2: 9.9 → 3: 10.2 ↙	4. Serie 5 Skott 
	Serie 29 Total 130		1: 10.4x ↘ 2: 9.5 ↗ 3: 10.3 ↗ 4: 10.8x ↘ 5: 10.8x ↘
			Serie 49 Total 179
5. Serie 5 Skott		1: 10.6x ↙ 2: 9.8 ← 3: 10.0 ↗ 4: 9.5 ↗ 5: 9.6 ↗	
	Serie 47 Total 226		

Skjutlag <b>1</b>	Tavla <b>21</b>	<b>Ulf Ohlsson</b>	
Ramselefors		Umeå	Öpp Vb
13.08.2017		SM Banskytte Ställning 2017	Ramselefors SKF
Prov		1: 10.7x ↘ 2: 10.4x ↘ 3: 8.9 ↘ 4: 10.2 ↗ 5: 10.2 ↗	1. Serie 5 Skott
		Serie 48 Total 0	
			1: 10.5x ↘ 2: 10.3 → 3: 10.2 ↘ 4: 9.7 ↘ 5: 10.5x ←
2. Serie 5 Skott		1: 8.9 ↑ 2: 9.9 → 3: 9.8 ↘ 4: 10.3 ↘ 5: 10.4x ↘	4. Serie 5 Skott
		Serie 46 Total 95	
			1: 6.8 ↙ 2: 9.9 ↓ 3: 7.9 ↙ 4: 4.8 ↙ 5: 5.5 ↙
Prov		1: 10.6x ↘ 2: 9.8 ↙ 3: 10.1 ↗	4. Serie 5 Skott
		Serie 29 Total 126	
			1: 9.8 → 2: 10.4 ↓ 3: 10.0 ↓ 4: 9.9 ↗ 5: 9.9 ↘
5. Serie 5 Skott		1: 7.3 ↗ 2: 8.3 ↗ 3: 9.6 ↗ 4: 9.2 ↘ 5: 7.8 ←	
		Serie 40 Total 213	

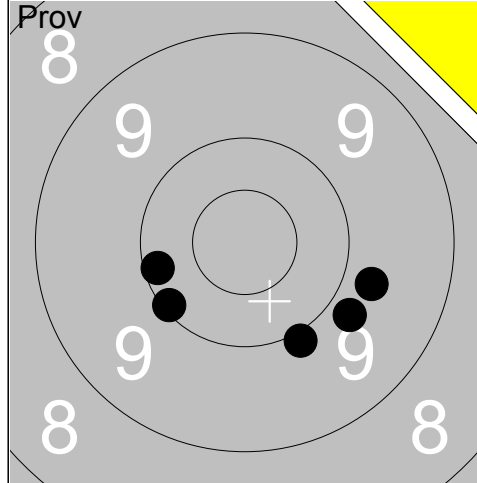

1:	9.8	↘
2:	10.1	←
3:	10.1	↙
4:	10.0	↘
5:	9.8	→
Serie		48
Total		0

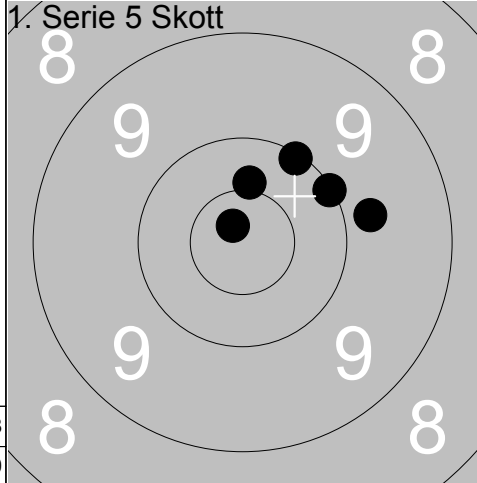

1:	10.1	↗
2:	10.8x	↖
3:	10.1	↗
4:	9.8	→
5:	10.4x	↑
Serie		49
Total		49

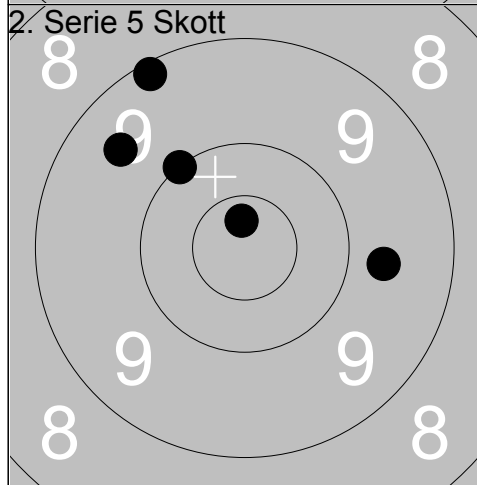

1:	9.7	→
2:	10.7x	↑
3:	10.0	↗
4:	9.5	↗
5:	9.1	↗
Serie		47
Total		96

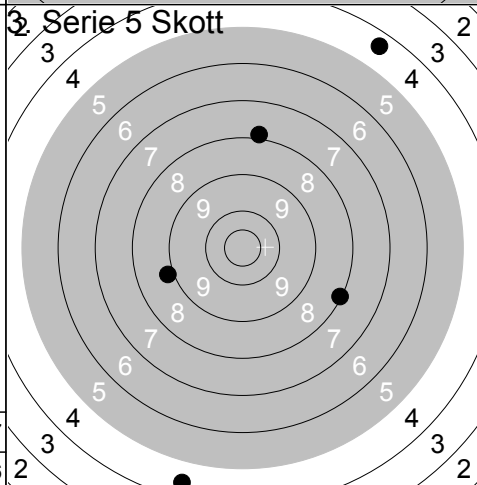

1:	7.9	↑
2:	4.4	↗
3:	8.9	←
4:	4.5	↓
5:	8.1	⇒
Serie		31
Total		127

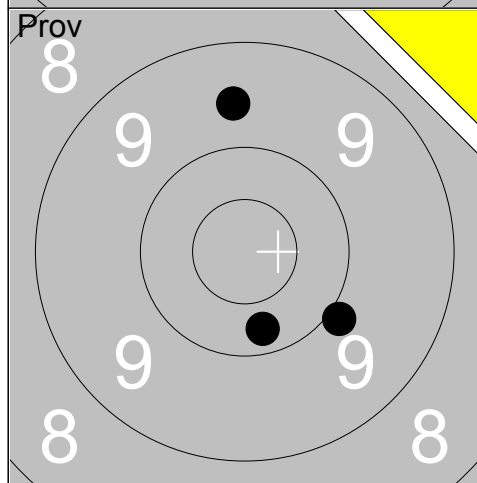

1:	10.3	↓
2:	9.9	↘
3:	9.6	↑
Serie		28
Total		127

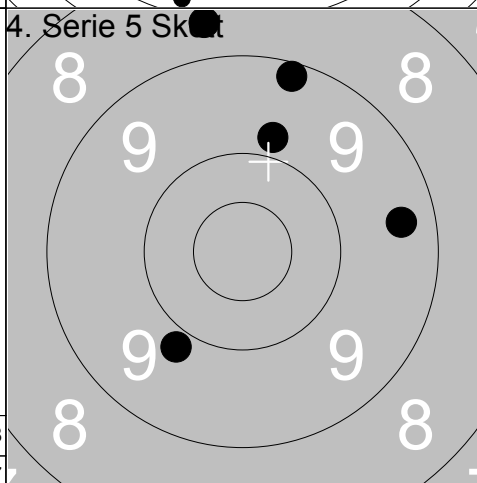

1:	8.7	↑
2:	9.2	↑
3:	9.4	→
4:	9.8	↑
5:	9.8	↙
Serie		44
Total		171

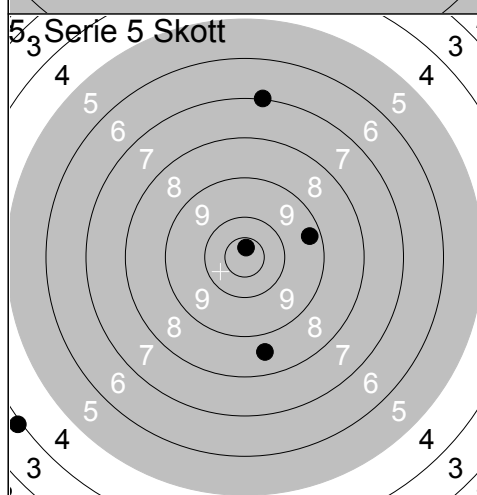

1:	7.0	↑
2:	10.7x	↑
3:	9.3	→
4:	3.9	↙
5:	8.6	↓
Serie		37
Total		208

Skjutlag <b>2</b>	Tavla <b>2</b>	<b>Berit Olsson</b>	
Ramselefors		Öved-Östraby	Öpp Sk
13.08.2017		SM Banskytte Ställning 2017	Ramselefors SKF
Prov		1: 10.3 ↗ 2: 10.3 ↗ 3: 10.4 ↘ 4: 10.3 ↘ 5: 10.4 →	1. Serie 5 Skott
		Serie 50 Total 0	1: 10.4x ↘ 2: 10.4 ↘ 3: 9.3 ↗ 4: 10.5x ↘ 5: 10.5x ↗
2. Serie 5 Skott		1: 10.8x ↑ 2: 10.3 → 3: 9.7 ↘ 4: 10.4 ↑ 5: 10.4 ↘	3. Serie 5 Skott
		Serie 49 Total 98	1: 7.4 ← 2: 10.5x ↘ 3: 10.7x ↑ 4: 10.6x ← 5: 8.0 ←
Prov		1: 10.6x ← 2: 10.3 ↗ 3: 10.0 ↗	4. Serie 5 Skott
		Serie 30 Total 143	1: 9.7 ← 2: 10.3 ↗ 3: 10.4x ↑ 4: 10.5x ↘ 5: 10.5x ←
5. Serie 5 Skott		1: 7.7 ↘ 2: 8.7 ← 3: 7.9 ↘ 4: 7.8 ↘ 5: 10.2 ↘	
		Serie 39 Total 231	

Skjutlag	Tavla	Dan-Ivan Karlsson			
2	3	Ramselefors	Ramselefors	Vet	Vb
13.08.2017		SM Banskytte Ställning 2017	Ramselefors SKF		
Prov 	1: 9.4 → 2: 10.3 → 3: 9.3 ↙ 4: 10.3 ↗ 5: 9.6 ↖	1. Serie 5 Skott 	1: 9.5 ↓ 2: 9.8 ↑ 3: 9.9 ↑ 4: 10.6x ↙ 5: 9.7 ↖	Serie 47 Total 0	Serie 46 Total 46
2. Serie 5 Skott 	1: 9.3 ← 2: 10.4 ↖ 3: 10.8x ↓ 4: 9.9 ↑ 5: 9.9 ↗	3. Serie 5 Skott 	1: 9.4 ↑ 2: 10.1 ← 3: 10.6x ← 4: 9.0 ↗ 5: 7.6 ↗	Serie 47 Total 93	Serie 45 Total 138
Prov 	1: 9.4 → 2: 10.2 ↙ 3: 10.3 ↙	4. Serie 5 Skott 	1: 9.8 ↑ 2: 9.4 ← 3: 10.3 ← 4: 9.6 ↖ 5: 10.4x ↘	Serie 29 Total 138	Serie 47 Total 185
5. Serie 5 Skott 	1: 10.3 ← 2: 8.9 ↗ 3: 9.7 ↗ 4: 9.8 ↘ 5: 9.0 ↗				
Serie 45 Total 230					

Skjutlag <b>2</b>	Tavla <b>4</b>	<b>Bo Allansson</b>	
Ramselefors		Stenungsund	Vet Vs
13.08.2017		SM Banskytte Ställning 2017	Ramselefors SKF
Prov 	1: 10.7x ↖ 2: 10.8x ↖ 3: 10.5x ↗ 4: 10.1 ↘ 5: 9.5 ↖ Serie 49 Total 0	1. Serie 5 Skott 	1: 10.1 ↘ 2: 9.9 ↖ 3: 9.2 ↘ 4: 7.6 ↘ 5: 9.4 ↖ Serie 44 Total 44
2. Serie 5 Skott 	1: 10.6x ↖ 2: 10.6x ↖ 3: 10.3 ↖ 4: 10.6x ↘ 5: 9.9 ↘ Serie 49 Total 93	3. Serie 5 Skott 	1: 8.8 ↗ 2: 8.6 ↗ 3: 8.7 ↖ 4: 9.0 ↘ 5: 8.0 → Serie 41 Total 134
Prov 	1: 10.2 ↘ 2: 10.5x → 3: 10.1 ↗ Serie 30 Total 134	4. Serie 5 Skott 	1: 10.3 ↖ 2: 9.7 ↖ 3: 10.2 ↖ 4: 10.4x ↖ 5: 9.1 ↖ Serie 48 Total 182
5. Serie 5 Skott 	1: 9.7 ↖ 2: 10.5x ↖ 3: 9.5 → 4: 8.9 ↗ 5: 7.2 ↘ Serie 43 Total 225		

<p><b>Prov</b></p> <table border="1" style="width:100%; border-collapse: collapse; margin-top: 10px;"> <tr> <td style="text-align: right;">Serie</td> <td style="text-align: right;">47</td> </tr> <tr> <td style="text-align: right;">Total</td> <td style="text-align: right;">0</td> </tr> </table>	Serie	47	Total	0	<p><b>1. Serie 5 Skott</b></p> <table border="1" style="width:100%; border-collapse: collapse; margin-top: 10px;"> <tr> <td style="text-align: right;">Serie</td> <td style="text-align: right;">45</td> </tr> <tr> <td style="text-align: right;">Total</td> <td style="text-align: right;">45</td> </tr> </table>	Serie	45	Total	45	<table border="1" style="width:100%; border-collapse: collapse;"> <tr> <td style="text-align: right;">1:</td> <td style="text-align: right;">9.9</td> <td style="text-align: center;">↗</td> </tr> <tr> <td style="text-align: right;">2:</td> <td style="text-align: right;">10.2</td> <td style="text-align: center;">↖</td> </tr> <tr> <td style="text-align: right;">3:</td> <td style="text-align: right;">9.8</td> <td style="text-align: center;">→</td> </tr> <tr> <td style="text-align: right;">4:</td> <td style="text-align: right;">9.9</td> <td style="text-align: center;">↙</td> </tr> <tr> <td style="text-align: right;">5:</td> <td style="text-align: right;">10.8x</td> <td style="text-align: center;">←</td> </tr> </table>	1:	9.9	↗	2:	10.2	↖	3:	9.8	→	4:	9.9	↙	5:	10.8x	←
Serie	47																								
Total	0																								
Serie	45																								
Total	45																								
1:	9.9	↗																							
2:	10.2	↖																							
3:	9.8	→																							
4:	9.9	↙																							
5:	10.8x	←																							
<p><b>2. Serie 5 Skott</b></p> <table border="1" style="width:100%; border-collapse: collapse; margin-top: 10px;"> <tr> <td style="text-align: right;">Serie</td> <td style="text-align: right;">46</td> </tr> <tr> <td style="text-align: right;">Total</td> <td style="text-align: right;">91</td> </tr> </table>	Serie	46	Total	91	<p><b>3. Serie 5 Skott</b></p> <table border="1" style="width:100%; border-collapse: collapse; margin-top: 10px;"> <tr> <td style="text-align: right;">Serie</td> <td style="text-align: right;">38</td> </tr> <tr> <td style="text-align: right;">Total</td> <td style="text-align: right;">129</td> </tr> </table>	Serie	38	Total	129	<table border="1" style="width:100%; border-collapse: collapse;"> <tr> <td style="text-align: right;">1:</td> <td style="text-align: right;">10.2</td> <td style="text-align: center;">→</td> </tr> <tr> <td style="text-align: right;">2:</td> <td style="text-align: right;">10.3</td> <td style="text-align: center;">→</td> </tr> <tr> <td style="text-align: right;">3:</td> <td style="text-align: right;">9.9</td> <td style="text-align: center;">→</td> </tr> <tr> <td style="text-align: right;">4:</td> <td style="text-align: right;">10.2</td> <td style="text-align: center;">→</td> </tr> <tr> <td style="text-align: right;">5:</td> <td style="text-align: right;">7.0</td> <td style="text-align: center;">↘</td> </tr> </table>	1:	10.2	→	2:	10.3	→	3:	9.9	→	4:	10.2	→	5:	7.0	↘
Serie	46																								
Total	91																								
Serie	38																								
Total	129																								
1:	10.2	→																							
2:	10.3	→																							
3:	9.9	→																							
4:	10.2	→																							
5:	7.0	↘																							
<p><b>Prov</b></p> <table border="1" style="width:100%; border-collapse: collapse; margin-top: 10px;"> <tr> <td style="text-align: right;">Serie</td> <td style="text-align: right;">29</td> </tr> <tr> <td style="text-align: right;">Total</td> <td style="text-align: right;">129</td> </tr> </table>	Serie	29	Total	129	<p><b>4. Serie 5 Skott</b></p> <table border="1" style="width:100%; border-collapse: collapse; margin-top: 10px;"> <tr> <td style="text-align: right;">Serie</td> <td style="text-align: right;">48</td> </tr> <tr> <td style="text-align: right;">Total</td> <td style="text-align: right;">177</td> </tr> </table>	Serie	48	Total	177	<table border="1" style="width:100%; border-collapse: collapse;"> <tr> <td style="text-align: right;">1:</td> <td style="text-align: right;">10.4</td> <td style="text-align: center;">↑</td> </tr> <tr> <td style="text-align: right;">2:</td> <td style="text-align: right;">10.2</td> <td style="text-align: center;">→</td> </tr> <tr> <td style="text-align: right;">3:</td> <td style="text-align: right;">9.1</td> <td style="text-align: center;">↙</td> </tr> </table>	1:	10.4	↑	2:	10.2	→	3:	9.1	↙						
Serie	29																								
Total	129																								
Serie	48																								
Total	177																								
1:	10.4	↑																							
2:	10.2	→																							
3:	9.1	↙																							
<p><b>5. Serie 5 Skott</b></p> <table border="1" style="width:100%; border-collapse: collapse; margin-top: 10px;"> <tr> <td style="text-align: right;">Serie</td> <td style="text-align: right;">43</td> </tr> <tr> <td style="text-align: right;">Total</td> <td style="text-align: right;">220</td> </tr> </table>	Serie	43	Total	220		<table border="1" style="width:100%; border-collapse: collapse;"> <tr> <td style="text-align: right;">1:</td> <td style="text-align: right;">9.4</td> <td style="text-align: center;">↙</td> </tr> <tr> <td style="text-align: right;">2:</td> <td style="text-align: right;">9.2</td> <td style="text-align: center;">→</td> </tr> <tr> <td style="text-align: right;">3:</td> <td style="text-align: right;">10.6x</td> <td style="text-align: center;">↘</td> </tr> <tr> <td style="text-align: right;">4:</td> <td style="text-align: right;">8.7</td> <td style="text-align: center;">→</td> </tr> <tr> <td style="text-align: right;">5:</td> <td style="text-align: right;">7.8</td> <td style="text-align: center;">←</td> </tr> </table>	1:	9.4	↙	2:	9.2	→	3:	10.6x	↘	4:	8.7	→	5:	7.8	←				
Serie	43																								
Total	220																								
1:	9.4	↙																							
2:	9.2	→																							
3:	10.6x	↘																							
4:	8.7	→																							
5:	7.8	←																							

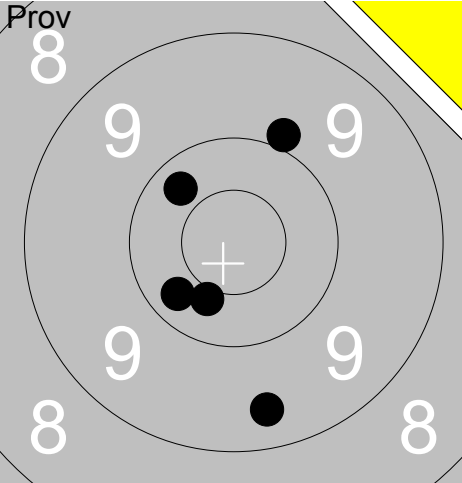
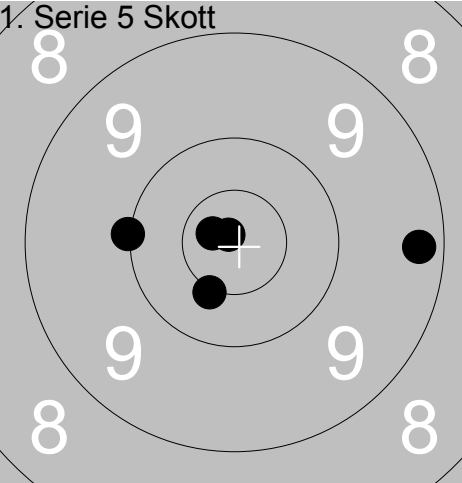
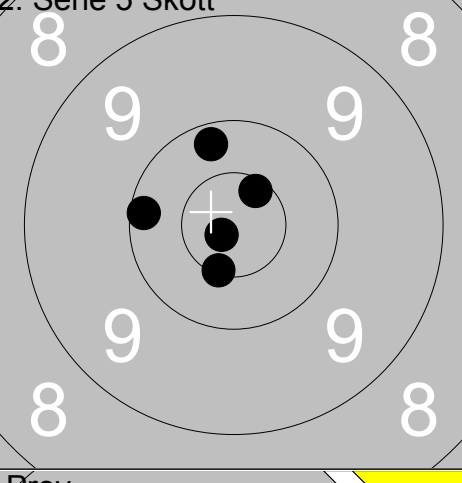
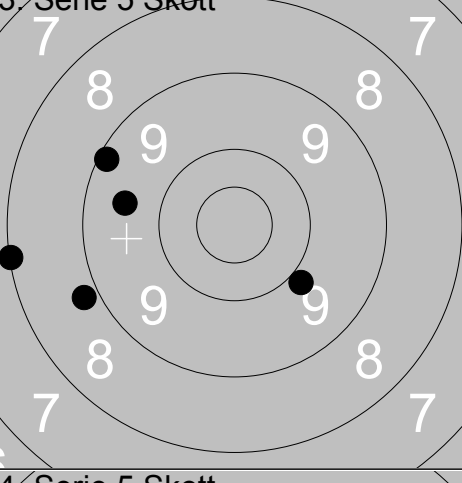
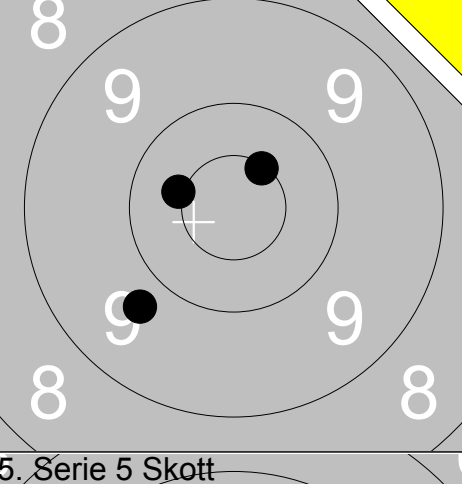
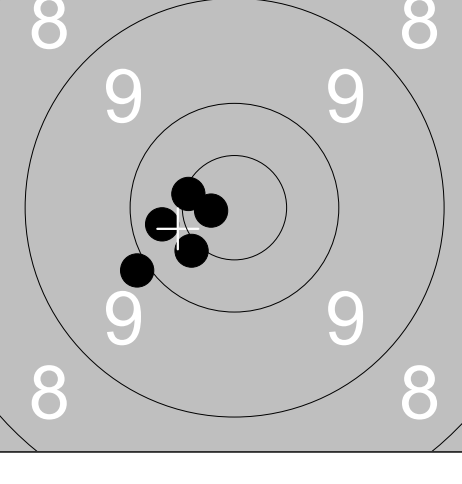
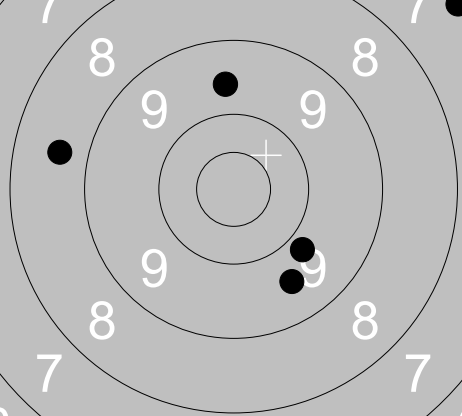

Skjutlag <b>2</b>	Tavla <b>6</b>	<b>Jane Jönsson</b>	
Ramselefors		Öved-Östraby	Öpp Sk
13.08.2017		SM Banskytte Ställning 2017	Ramselefors SKF
Prov 	1: 9.9 ↗ 2: 9.4 ↓ 3: 10.3 ↗ 4: 10.3 ↓ 5: 10.4 ↓	1. Serie 5 Skott 	1: 9.3 → 2: 10.9x ↗ 3: 10.5x ↓ 4: 10.7x ↗ 5: 10.0 ←
	Serie 48 Total 0		Serie 49 Total 49
2. Serie 5 Skott 	1: 10.6x ↗ 2: 10.5x ↓ 3: 10.2 ↗ 4: 10.1 ← 5: 10.8x ↙	3. Serie 5 Skott 	1: 9.9 ↓ 2: 8.0 ← 3: 9.1 ↗ 4: 8.8 ↓ 5: 9.6 ←
	Serie 50 Total 99		Serie 43 Total 142
Prov 	1: 9.7 ↓ 2: 10.5x ↗ 3: 10.4x ←	4. Serie 5 Skott 	1: 9.9 ← 2: 10.4x ↓ 3: 10.3 ← 4: 10.7x ← 5: 10.5x ←
	Serie 29 Total 142		Serie 49 Total 191
5. Serie 5 Skott 	1: 9.8 ↓ 2: 8.6 ← 3: 9.6 ↗ 4: 9.6 ↓ 5: 7.1 ↗		
	Serie 42 Total 233		

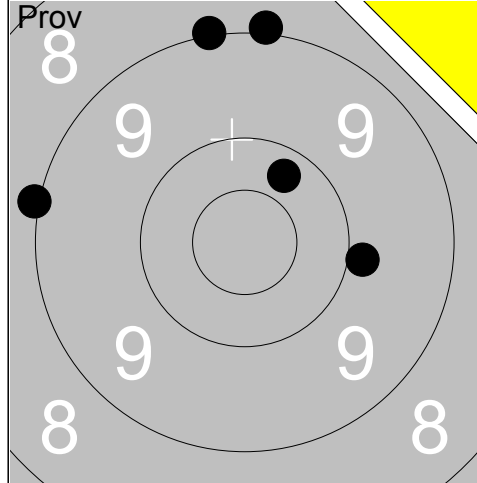

1:	10.3	↗
2:	9.0	↑
3:	9.0	↑
4:	9.9	→
5:	9.0	←

Serie	46
Total	0

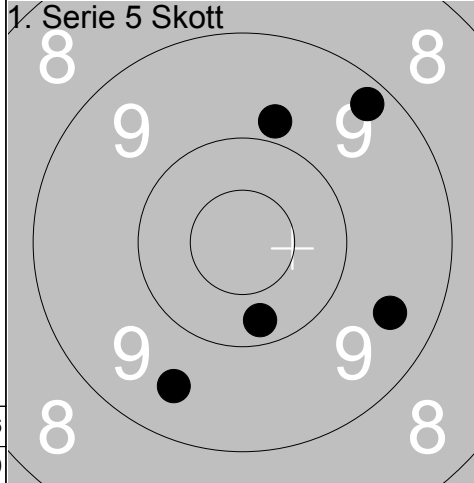

1:	9.2	↗
2:	9.8	↑
3:	9.5	↘
4:	9.5	↓
5:	10.2	↓

Serie	46
Total	46

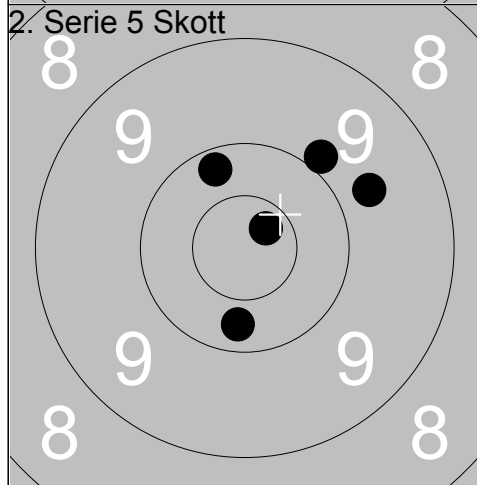

1:	10.7x	↗
2:	9.7	↗
3:	9.9	↗
4:	10.2	↑
5:	10.3	↓

Serie	48
Total	94

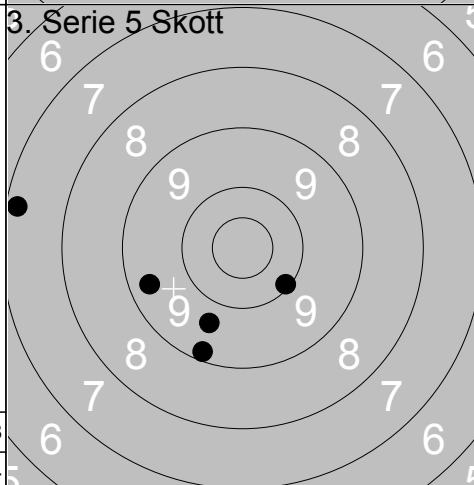

1:	9.2	↓
2:	10.1	↘
3:	9.7	↓
4:	9.4	←
5:	7.2	←

Serie	44
Total	138

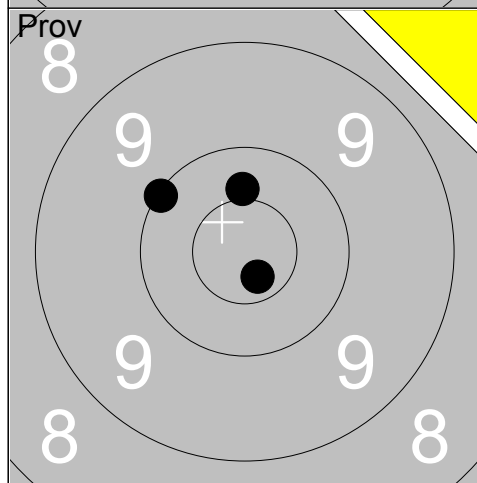

1:	10.1	↖
2:	10.4	↑
3:	10.7x	↓

Serie	30
Total	138

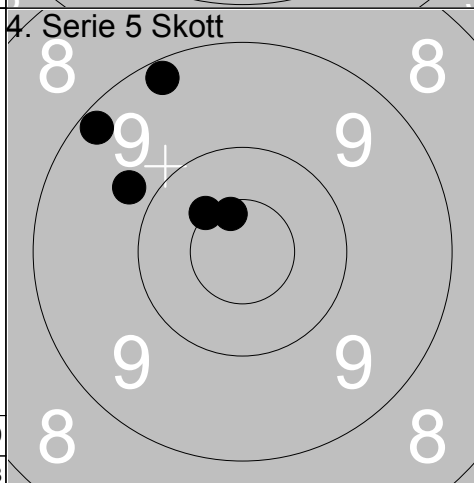

1:	9.2	↗
2:	9.8	↗
3:	10.6x	↗
4:	10.5x	↗
5:	9.2	↗

Serie	47
Total	185

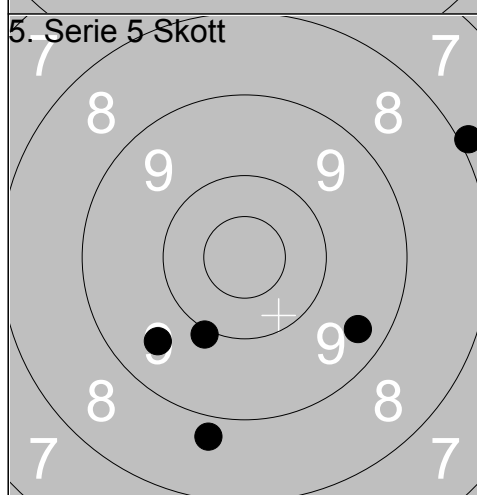

1:	10.0	↓
2:	9.5	↓
3:	9.4	↘
4:	7.9	↗
5:	8.8	↓

Serie	43
Total	228

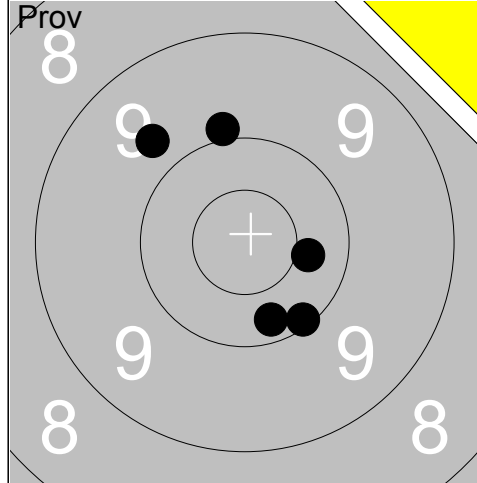

1:	10.4	→
2:	9.9	↑
3:	9.7	↗
4:	10.2	↓
5:	10.1	↓
Serie		48
Total		0

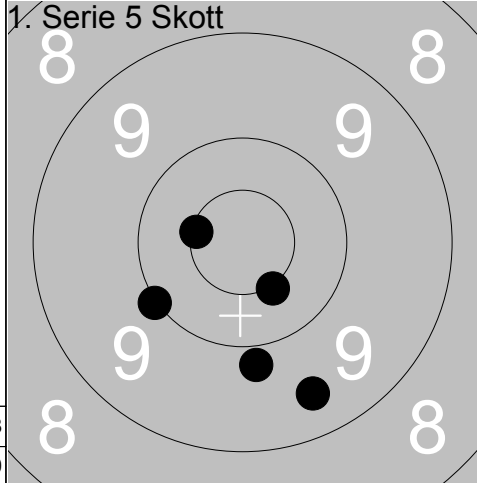

1:	10.5x	↓
2:	9.4	↓
3:	9.8	↓
4:	10.5x	←
5:	10.0	↙
Serie		48
Total		48

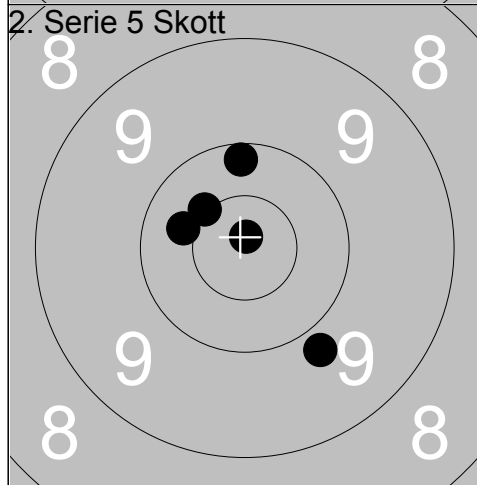

1:	10.2	↑
2:	10.4	←
3:	9.8	↓
4:	10.5x	↗
5:	10.8x	↑
Serie		49
Total		97

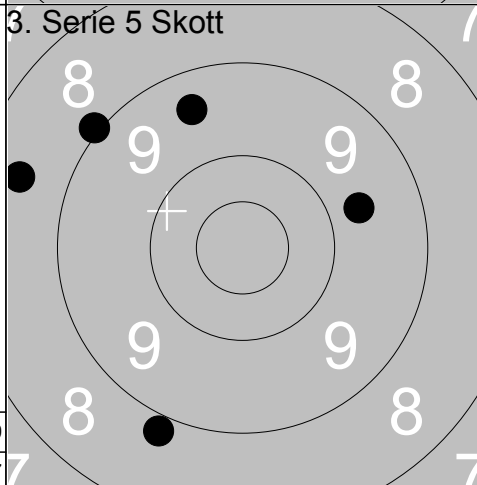

1:	9.7	→
2:	9.4	↗
3:	9.0	↗
4:	8.5	←
5:	8.9	↓
Serie		43
Total		140

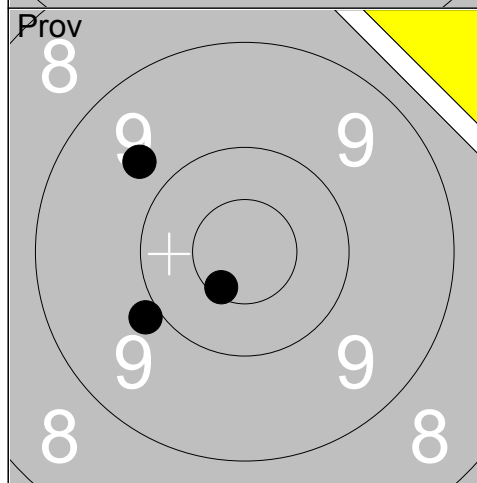

1:	9.9	↙
2:	9.7	↗
3:	10.6x	↙
Serie		28
Total		140

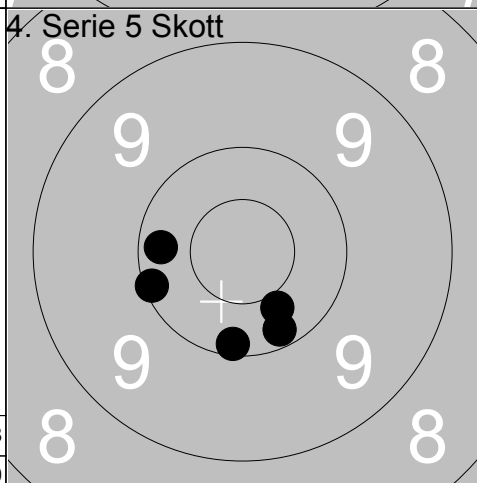

1:	10.1	↓
2:	10.2	←
3:	10.1	←
4:	10.2	↓
5:	10.4	↓
Serie		50
Total		190

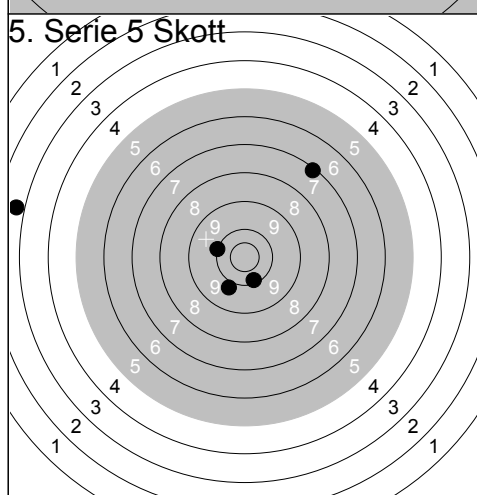

1:	10.1	↓
2:	10.0	←
3:	9.8	↓
4:	7.1	↗
5:	2.7	←
Serie		38
Total		228

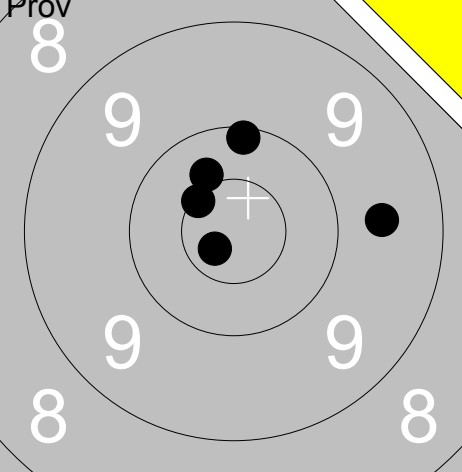
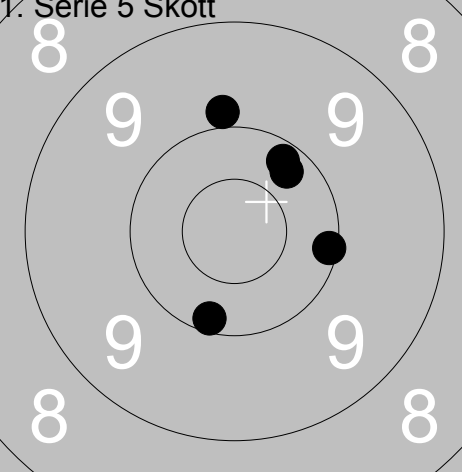
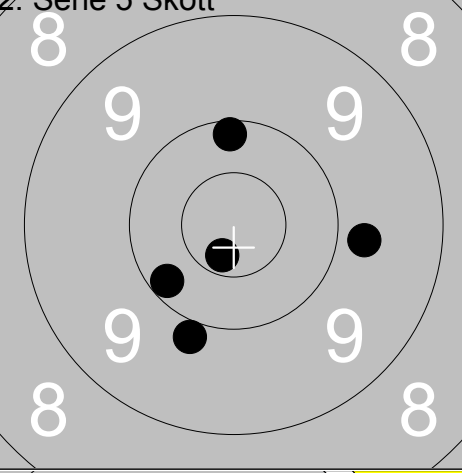
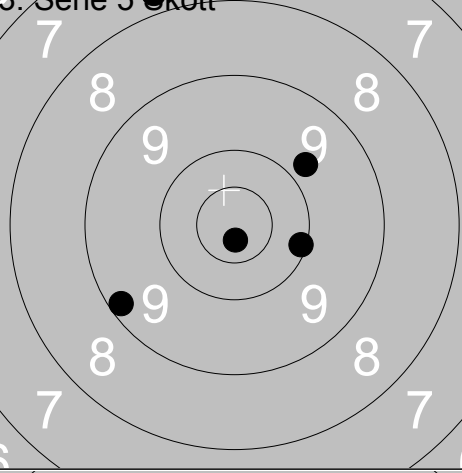
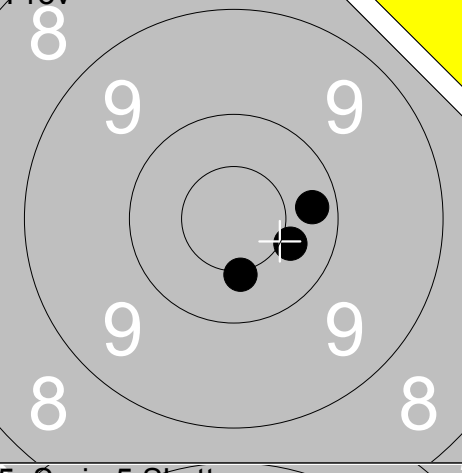
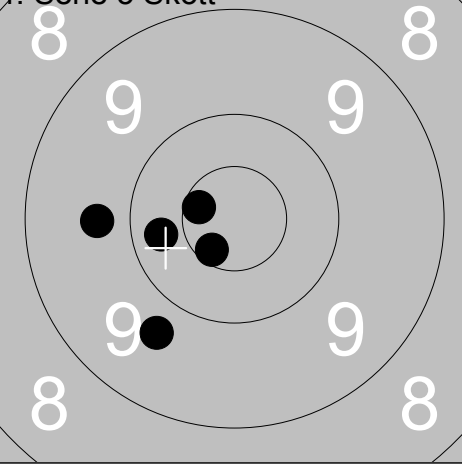
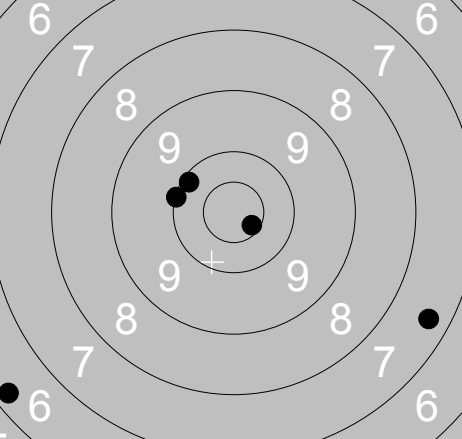
<p><b>Prov</b></p>  <p style="text-align: right;">Serie 49 Total 0</p>	<p><b>1. Serie 5 Skott</b></p>  <p style="text-align: right;">Serie 49 Total 49</p>	<p>1: 10.5x ↖ 2: 10.1 ↑ 3: 10.7x ↙ 4: 10.4 ↗ 5: 9.6 →</p> <p>1: 10.2 ↗ 2: 10.2 ↗ 3: 10.2 ↓ 4: 9.9 ↑ 5: 10.1 →</p>
<p><b>2. Serie 5 Skott</b></p>  <p style="text-align: right;">Serie 48 Total 97</p>	<p><b>3. Serie 5 Skott</b></p>  <p style="text-align: right;">Serie 45 Total 142</p>	<p>1: 10.1 ↑ 2: 9.9 ↓ 3: 9.8 → 4: 10.7x ↓ 5: 10.2 ↙</p> <p>1: 9.8 ↗ 2: 10.1 → 3: 9.2 ↙ 4: 7.8 ↑ 5: 10.8x ↓</p>
<p><b>Prov</b></p>  <p style="text-align: right;">Serie 30 Total 142</p>	<p><b>4. Serie 5 Skott</b></p>  <p style="text-align: right;">Serie 48 Total 190</p>	<p>1: 10.4 → 2: 10.5x ↓ 3: 10.2 →</p> <p>1: 9.7 ↓ 2: 10.6x ← 3: 9.7 ← 4: 10.6x ↓ 5: 10.3 ←</p>
<p><b>5. Serie 5 Skott</b></p>  <p style="text-align: right;">Serie 43 Total 233</p>	<p>1: 10.0 ← 2: 10.6x ↓ 3: 10.1 ↗ 4: 7.4 ↓ 5: 6.3 ↙</p>	

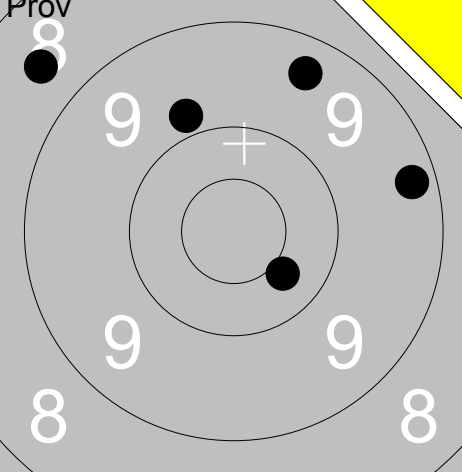
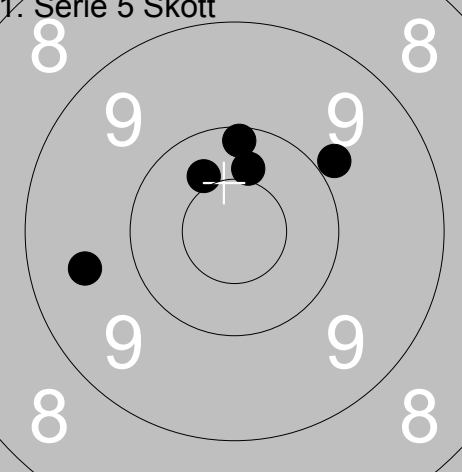
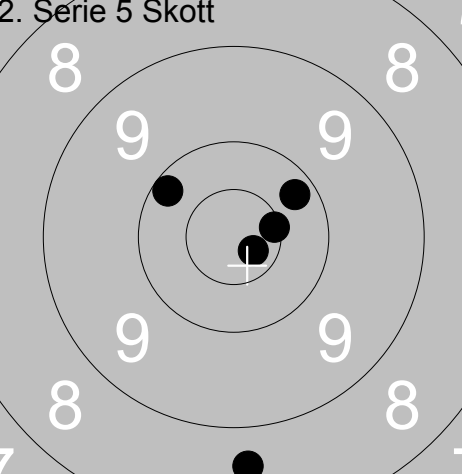
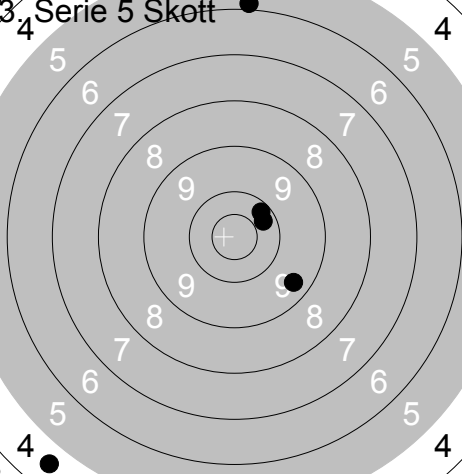
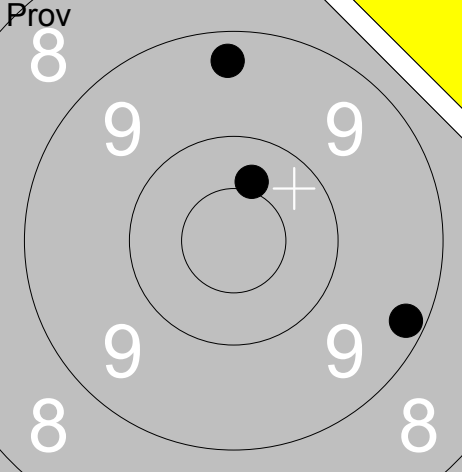
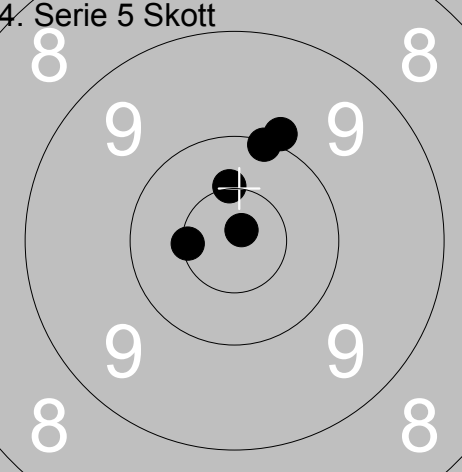
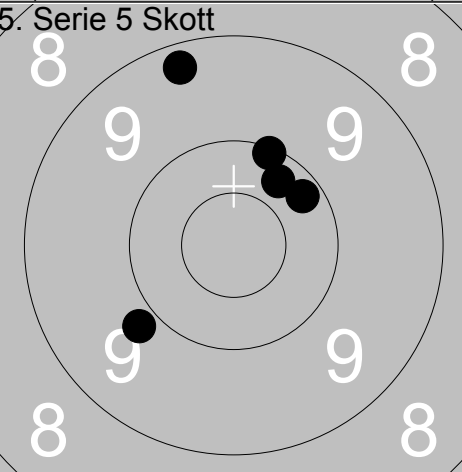
Prov 	1: 9.3 → 2: 10.4 ↘ 3: 9.8 ↑ 4: 9.4 ↑ 5: 8.6 ↗ <hr/> Serie 45 Total 0	1. Serie 5 Skott 	1: 9.9 ↗ 2: 10.1 ↑ 3: 10.4 ↑ 4: 10.4 ↗ 5: 9.6 ← <hr/> Serie 48 Total 48
2. Serie 5 Skott 	1: 10.5x → 2: 10.7x ↘ 3: 8.6 ↓ 4: 10.2 ↗ 5: 10.2 ↖ <hr/> Serie 48 Total 96	3. Serie 5 Skott 	1: 9.4 ↘ 2: 10.3 ↗ 3: 10.2 ↗ 4: 4.6 ↘ 5: 5.9 ↑ <hr/> Serie 38 Total 134
Prov 	1: 9.2 ⇒ 2: 9.3 ↑ 3: 10.4 ↑ <hr/> Serie 28 Total 134	4. Serie 5 Skott 	1: 10.1 ↑ 2: 10.8x ↑ 3: 9.9 ↑ 4: 10.5x ↑ 5: 10.5x ← <hr/> Serie 49 Total 183
5. Serie 5 Skott 	1: 10.3 ↑ 2: 10.1 ↑ 3: 9.8 ↖ 4: 10.2 ↗ 5: 9.3 ↑ <hr/> Serie 48 Total 231		

13.08.2017	SM Banskytte Ställning 2017	Ramselefors SKF
------------	-----------------------------	-----------------

<b>Prov</b> 	<table style="width:100%; border-collapse: collapse;"> <tr><td>1:</td><td>10.6x</td><td>↗</td></tr> <tr><td>2:</td><td>10.2</td><td>↘</td></tr> <tr><td>3:</td><td>10.0</td><td>↗</td></tr> <tr><td>4:</td><td>10.4</td><td>↗</td></tr> <tr><td>5:</td><td>8.8</td><td>↘</td></tr> <tr><td colspan="3">Serie 48</td></tr> <tr><td colspan="3">Total 0</td></tr> </table>	1:	10.6x	↗	2:	10.2	↘	3:	10.0	↗	4:	10.4	↗	5:	8.8	↘	Serie 48			Total 0			<b>1. Serie 5 Skott</b>  <table style="width:100%; border-collapse: collapse;"> <tr><td>1:</td><td>8.2</td><td>↘</td></tr> <tr><td>2:</td><td>8.1</td><td>↘</td></tr> <tr><td>3:</td><td>9.6</td><td>↗</td></tr> <tr><td>4:</td><td>10.0</td><td>↘</td></tr> <tr><td>5:</td><td>10.0</td><td>↗</td></tr> <tr><td colspan="3">Serie 45</td></tr> <tr><td colspan="3">Total 45</td></tr> </table>	1:	8.2	↘	2:	8.1	↘	3:	9.6	↗	4:	10.0	↘	5:	10.0	↗	Serie 45			Total 45		
1:	10.6x	↗																																										
2:	10.2	↘																																										
3:	10.0	↗																																										
4:	10.4	↗																																										
5:	8.8	↘																																										
Serie 48																																												
Total 0																																												
1:	8.2	↘																																										
2:	8.1	↘																																										
3:	9.6	↗																																										
4:	10.0	↘																																										
5:	10.0	↗																																										
Serie 45																																												
Total 45																																												
<b>2. Serie 5 Skott</b> 	<table style="width:100%; border-collapse: collapse;"> <tr><td>1:</td><td>8.6</td><td>↗</td></tr> <tr><td>2:</td><td>10.8x</td><td>↗</td></tr> <tr><td>3:</td><td>9.6</td><td>↗</td></tr> <tr><td>4:</td><td>8.9</td><td>↗</td></tr> <tr><td>5:</td><td>10.8x</td><td>←</td></tr> <tr><td colspan="3">Serie 45</td></tr> <tr><td colspan="3">Total 90</td></tr> </table>	1:	8.6	↗	2:	10.8x	↗	3:	9.6	↗	4:	8.9	↗	5:	10.8x	←	Serie 45			Total 90			<b>3. Serie 5 Skott</b>  <table style="width:100%; border-collapse: collapse;"> <tr><td>1:</td><td>9.9</td><td>↗</td></tr> <tr><td>2:</td><td>8.8</td><td>↘</td></tr> <tr><td>3:</td><td>8.6</td><td>↘</td></tr> <tr><td>4:</td><td>6.3</td><td>↘</td></tr> <tr><td>5:</td><td>10.6x</td><td>↗</td></tr> <tr><td colspan="3">Serie 41</td></tr> <tr><td colspan="3">Total 131</td></tr> </table>	1:	9.9	↗	2:	8.8	↘	3:	8.6	↘	4:	6.3	↘	5:	10.6x	↗	Serie 41			Total 131		
1:	8.6	↗																																										
2:	10.8x	↗																																										
3:	9.6	↗																																										
4:	8.9	↗																																										
5:	10.8x	←																																										
Serie 45																																												
Total 90																																												
1:	9.9	↗																																										
2:	8.8	↘																																										
3:	8.6	↘																																										
4:	6.3	↘																																										
5:	10.6x	↗																																										
Serie 41																																												
Total 131																																												
<b>Prov</b> 	<table style="width:100%; border-collapse: collapse;"> <tr><td>1:</td><td>7.8</td><td>↘</td></tr> <tr><td>2:</td><td>9.1</td><td>↘</td></tr> <tr><td>3:</td><td>10.7x</td><td>←</td></tr> <tr><td colspan="3">Serie 26</td></tr> <tr><td colspan="3">Total 131</td></tr> </table>	1:	7.8	↘	2:	9.1	↘	3:	10.7x	←	Serie 26			Total 131			<b>4. Serie 5 Skott</b>  <table style="width:100%; border-collapse: collapse;"> <tr><td>1:</td><td>9.6</td><td>↘</td></tr> <tr><td>2:</td><td>10.6x</td><td>→</td></tr> <tr><td>3:</td><td>8.2</td><td>↘</td></tr> <tr><td>4:</td><td>10.2</td><td>↖</td></tr> <tr><td>5:</td><td>9.0</td><td>↘</td></tr> <tr><td colspan="3">Serie 46</td></tr> <tr><td colspan="3">Total 177</td></tr> </table>	1:	9.6	↘	2:	10.6x	→	3:	8.2	↘	4:	10.2	↖	5:	9.0	↘	Serie 46			Total 177								
1:	7.8	↘																																										
2:	9.1	↘																																										
3:	10.7x	←																																										
Serie 26																																												
Total 131																																												
1:	9.6	↘																																										
2:	10.6x	→																																										
3:	8.2	↘																																										
4:	10.2	↖																																										
5:	9.0	↘																																										
Serie 46																																												
Total 177																																												
<b>5. Serie 5 Skott</b> 	<table style="width:100%; border-collapse: collapse;"> <tr><td>1:</td><td>8.5</td><td>↘</td></tr> <tr><td>2:</td><td>7.8</td><td>←</td></tr> <tr><td>3:</td><td>9.2</td><td>↘</td></tr> <tr><td>4:</td><td>7.7</td><td>↗</td></tr> <tr><td>5:</td><td>9.0</td><td>↗</td></tr> <tr><td colspan="3">Serie 40</td></tr> <tr><td colspan="3">Total 217</td></tr> </table>	1:	8.5	↘	2:	7.8	←	3:	9.2	↘	4:	7.7	↗	5:	9.0	↗	Serie 40			Total 217																								
1:	8.5	↘																																										
2:	7.8	←																																										
3:	9.2	↘																																										
4:	7.7	↗																																										
5:	9.0	↗																																										
Serie 40																																												
Total 217																																												

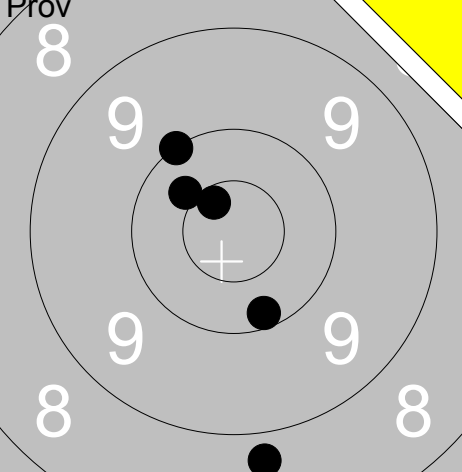
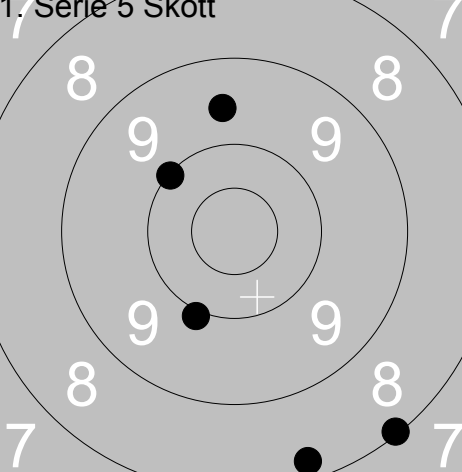
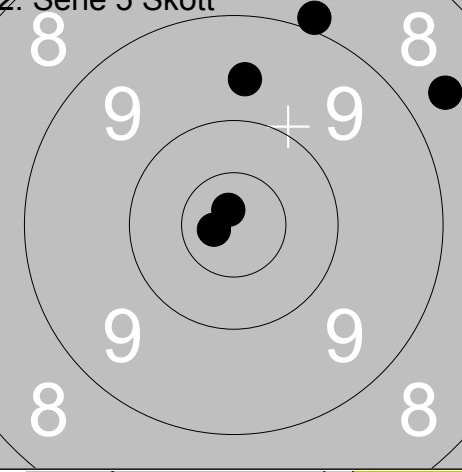
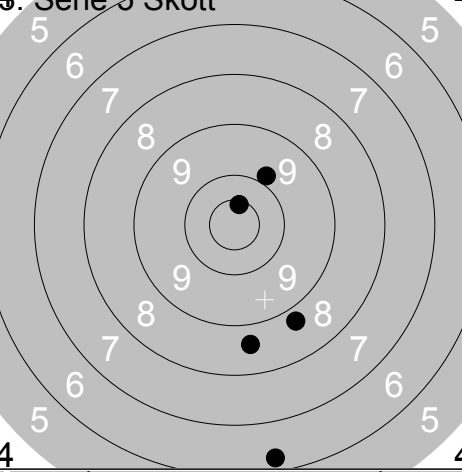
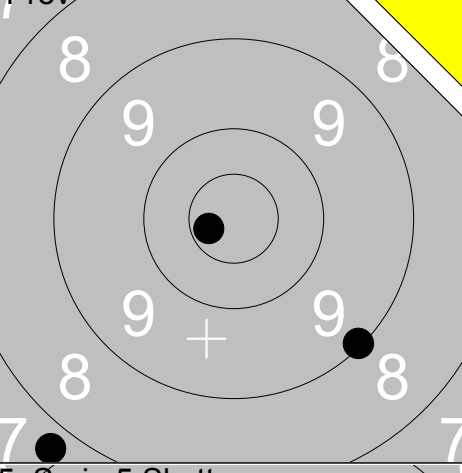
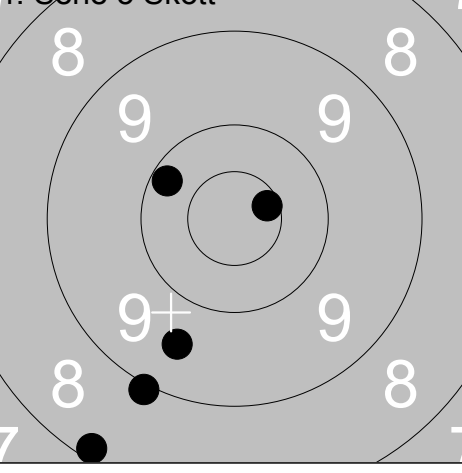
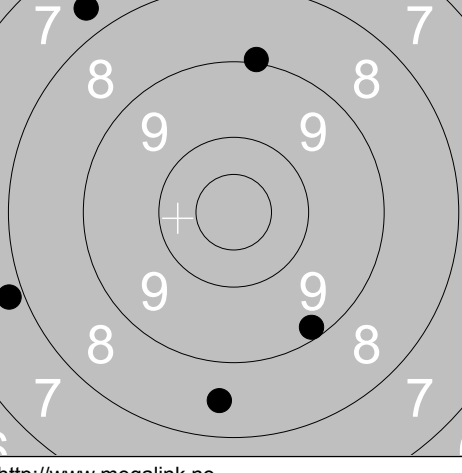

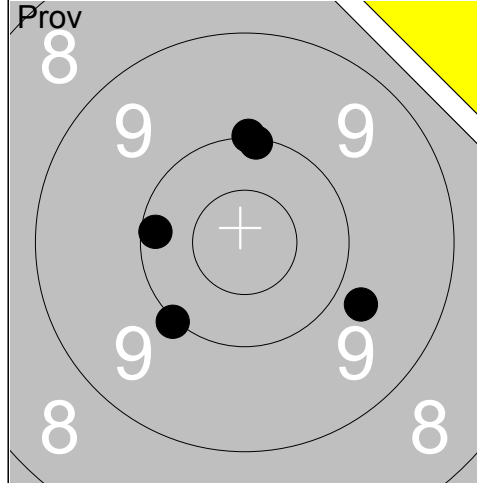
1:	10.1	↑
2:	10.0	↑
3:	9.8	→
4:	10.2	←
5:	10.0	↙
Serie		49
Total		0

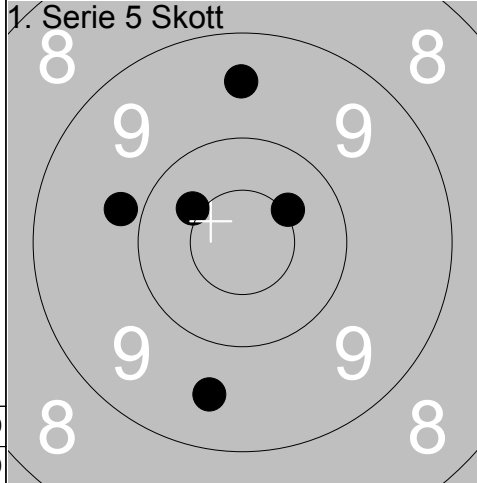

1:	9.8	←
2:	9.5	↑
3:	10.5x	↗
4:	10.4x	←
5:	9.5	↓
Serie		47
Total		47

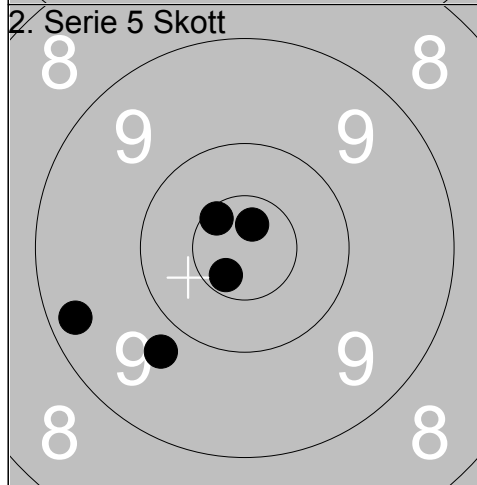

1:	9.3	←
2:	10.7x	↙
3:	10.6x	↗
4:	9.8	↙
5:	10.7x	↑
Serie		48
Total		95

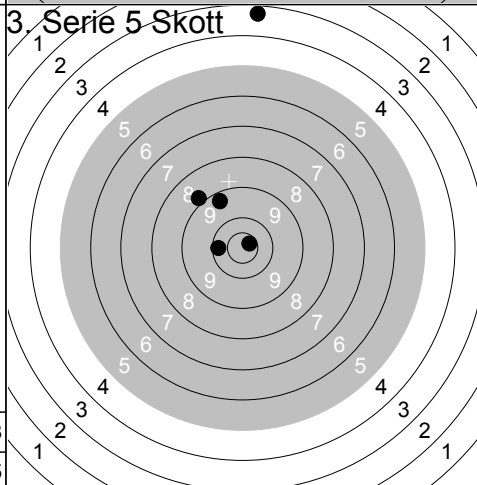

1:	10.7x	↗
2:	10.2	←
3:	9.3	↗
4:	3.3	↑
5:	8.8	↗
Serie		40
Total		135

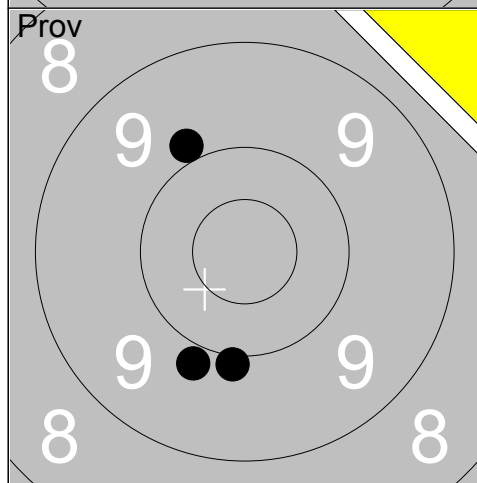

1:	9.9	↗
2:	9.9	↓
3:	9.9	↙
Serie		27
Total		135

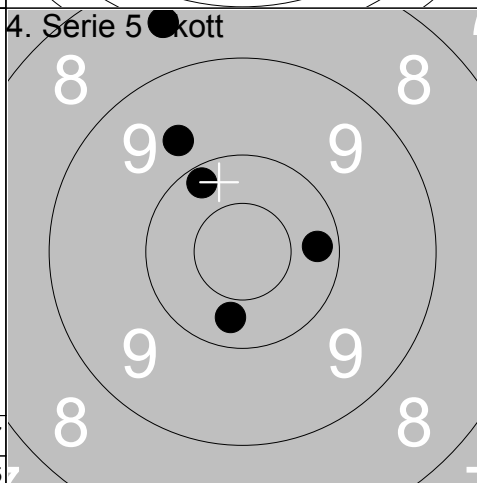

1:	8.5	↗
2:	10.2	→
3:	10.2	↗
4:	9.7	↗
5:	10.3	↓
Serie		47
Total		182

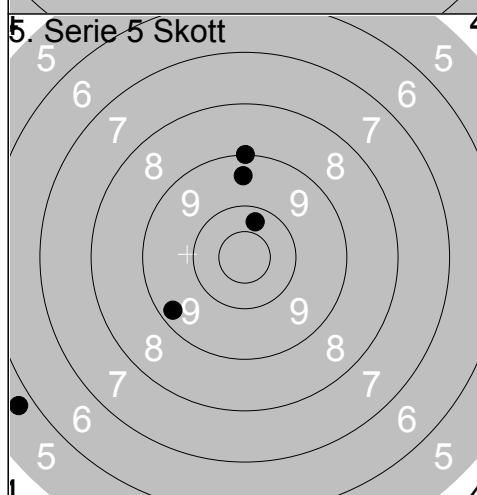

1:	9.3	←
2:	10.3	↑
3:	9.4	↑
4:	9.0	↑
5:	5.7	↙
Serie		42
Total		224

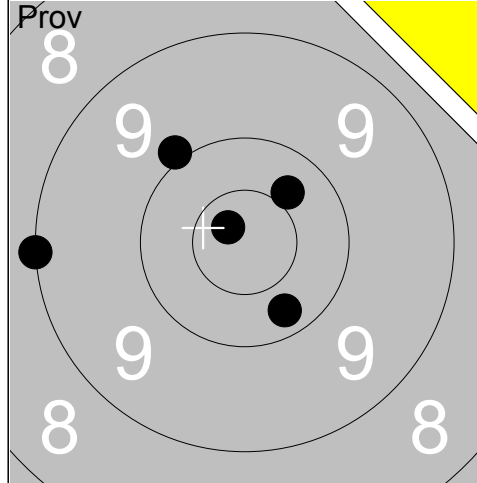

1:	9.0	←
2:	10.7x	↗
3:	10.2	↘
4:	10.4	↗
5:	9.9	↗
Serie		48
Total		0

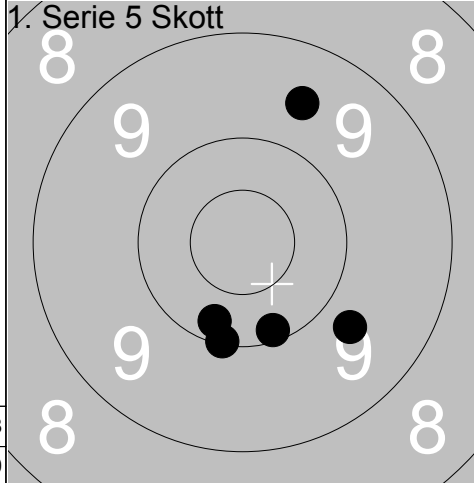

1:	9.6	↗
2:	10.2	↘
3:	9.7	↘
4:	10.1	↘
5:	10.1	↘
Serie		48
Total		48

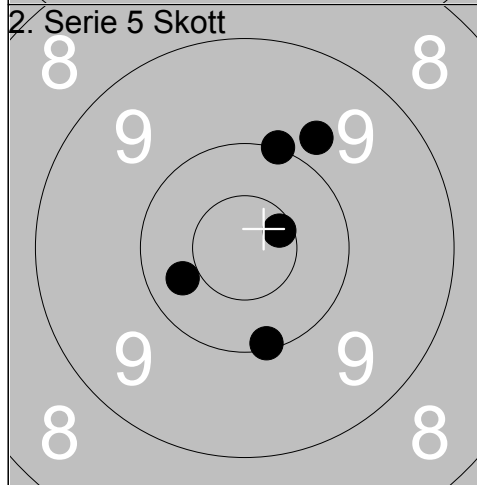

1:	9.8	↗
2:	10.0	↑
3:	10.3	←
4:	10.6x	→
5:	10.1	↘
Serie		49
Total		97

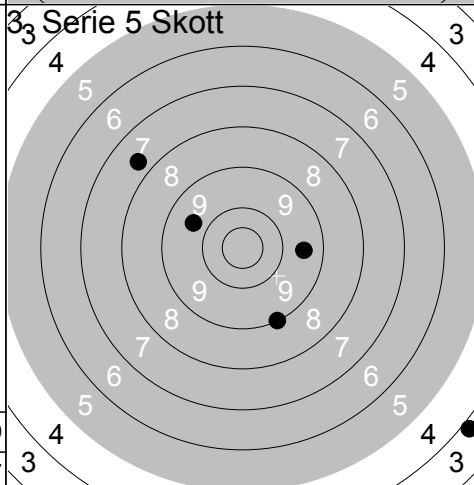

1:	9.7	↗
2:	9.0	↘
3:	9.5	→
4:	7.7	↗
5:	3.9	↘
Serie		37
Total		134

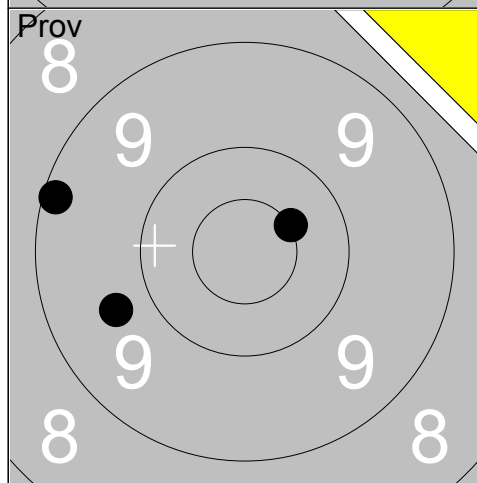

1:	10.5x	↗
2:	9.7	←
3:	9.2	←
Serie		28
Total		134

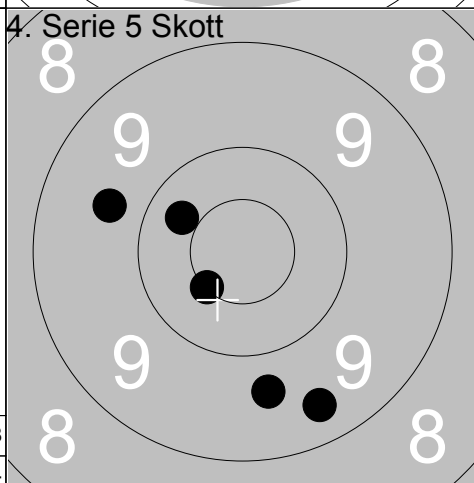

1:	9.7	↗
2:	9.4	↘
3:	10.3	↗
4:	10.5x	↘
5:	9.7	↘
Serie		47
Total		181

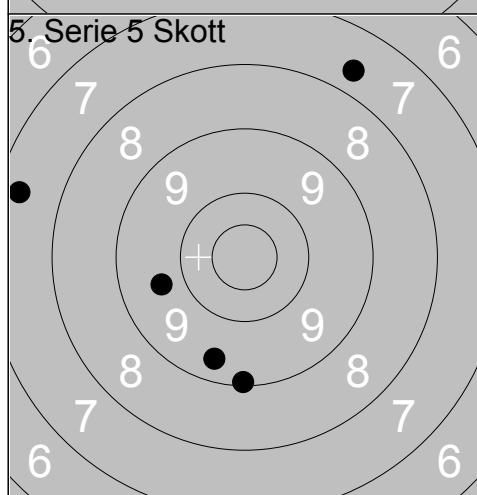

1:	9.7	←
2:	9.4	↘
3:	9.1	↘
4:	7.4	←
5:	7.7	↗
Serie		41
Total		222



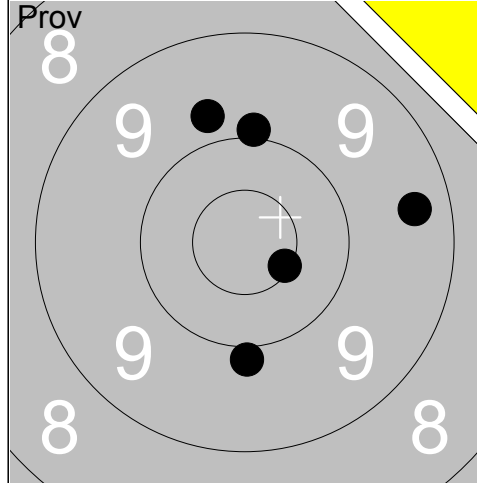

1:	9.4	→
2:	9.9	↑
3:	10.5x	⇒
4:	9.8	↑
5:	9.9	↓
Serie		46
Total		0

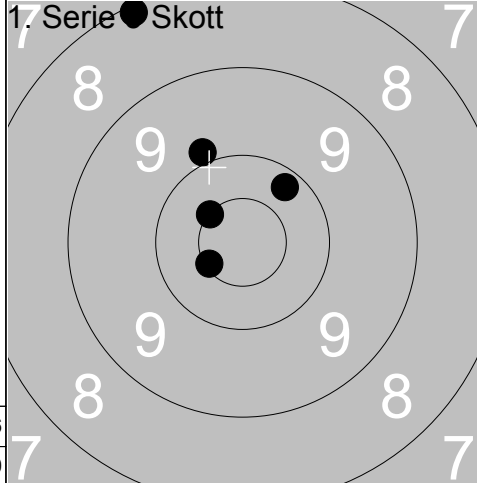

1:	8.1	↗
2:	10.2	↗
3:	9.9	↑
4:	10.5x	↖
5:	10.5x	↖
Serie		47
Total		47

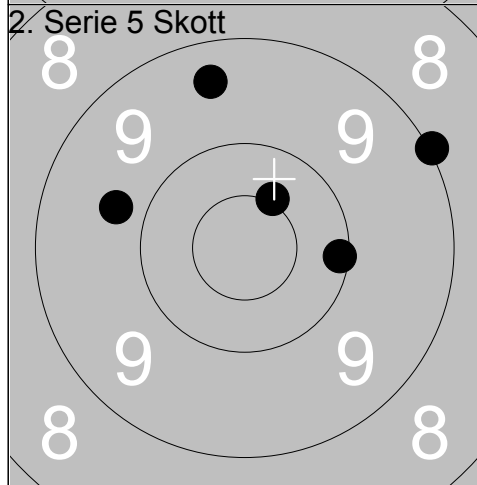

1:	9.4	↑
2:	10.4x	↗
3:	10.1	→
4:	9.0	⇒
5:	9.7	↖
Serie		47
Total		94

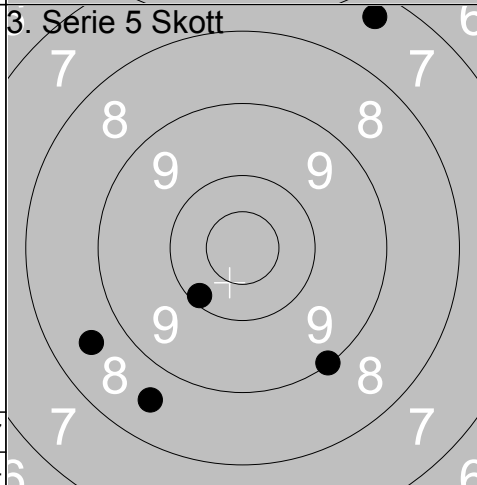

1:	9.0	↘
2:	10.1	↖
3:	7.3	↗
4:	8.6	↖
5:	8.6	↘
Serie		42
Total		136

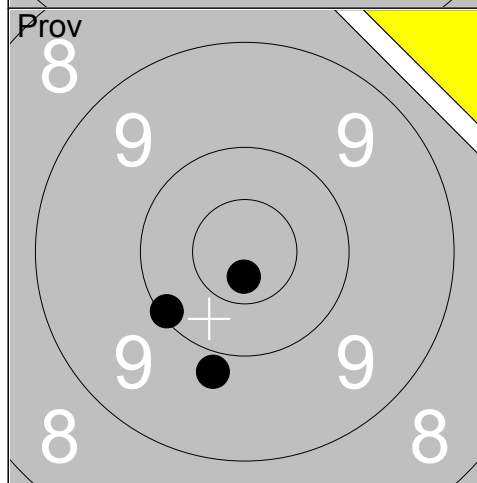

1:	10.7x	↓
2:	9.8	↓
3:	10.1	↖
Serie		29
Total		136

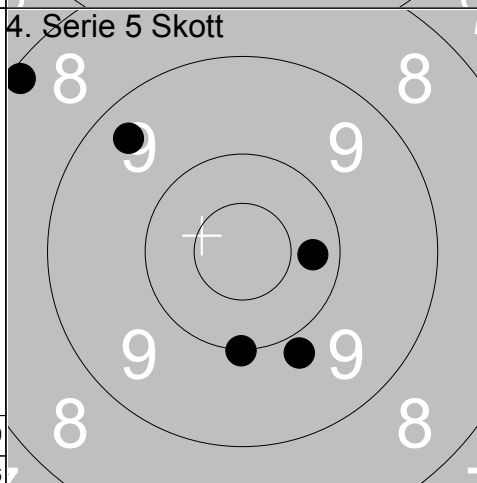

1:	10.3	→
2:	9.8	↘
3:	9.4	↗
4:	10.0	↓
5:	8.1	↗
Serie		46
Total		182

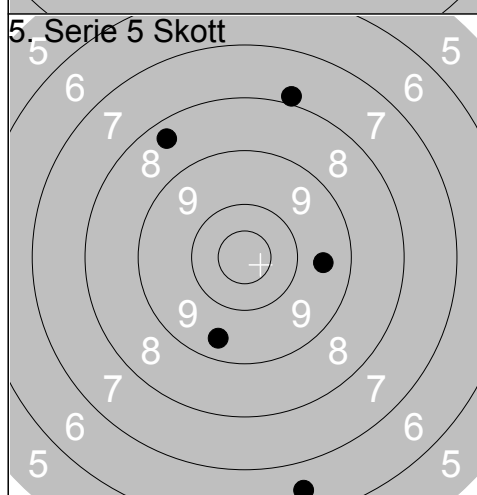

1:	9.4	↓
2:	7.9	↑
3:	9.5	→
4:	8.4	↗
5:	6.5	↓
Serie		39
Total		221

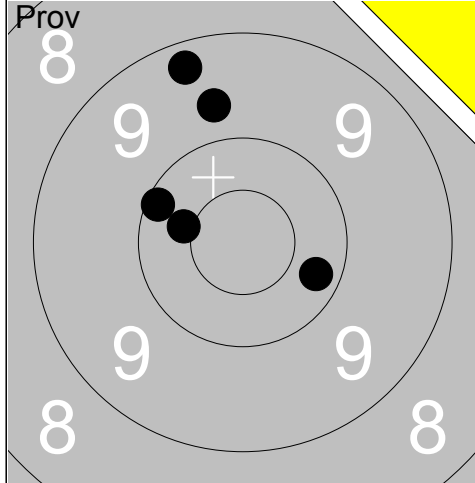

1:	9.3	↑
2:	10.2	→
3:	9.7	↑
4:	10.4	←
5:	10.1	↑
Serie		48
Total		0

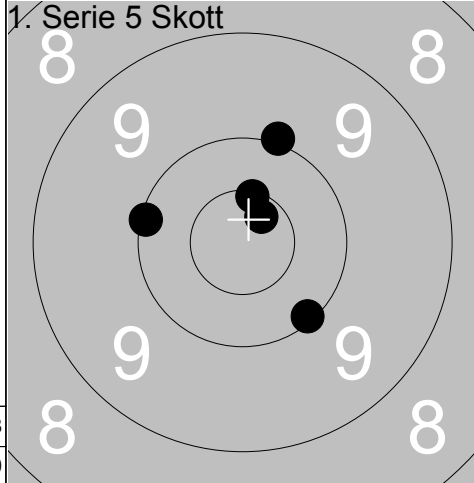

1:	10.1	↘
2:	10.0	↑
3:	10.7x	↗
4:	10.5x	↑
5:	10.1	←
Serie		50
Total		50

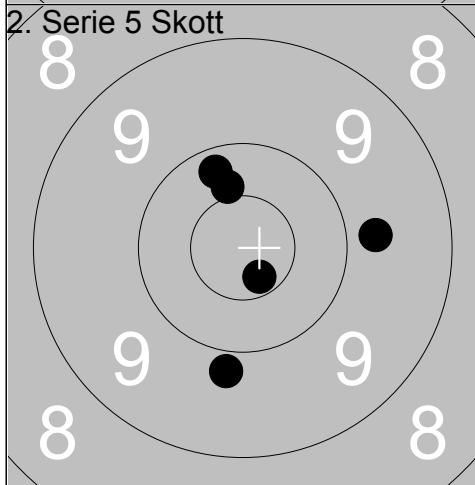

1:	10.4	↑
2:	9.7	→
3:	10.7x	↘
4:	10.2	↑
5:	9.8	↘
Serie		48
Total		98

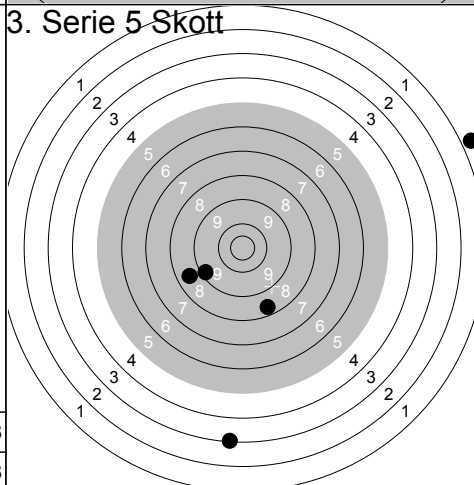

1:	8.6	←
2:	9.2	←
3:	8.4	↘
4:	3.1	↓
5:	0.0	→
Serie		28
Total		126

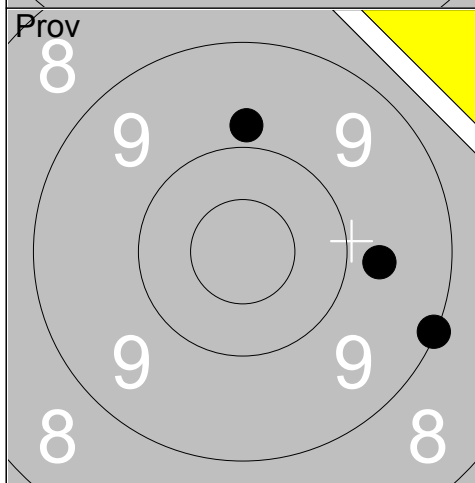

1:	9.0	→
2:	9.8	↑
3:	9.7	→
Serie		27
Total		126

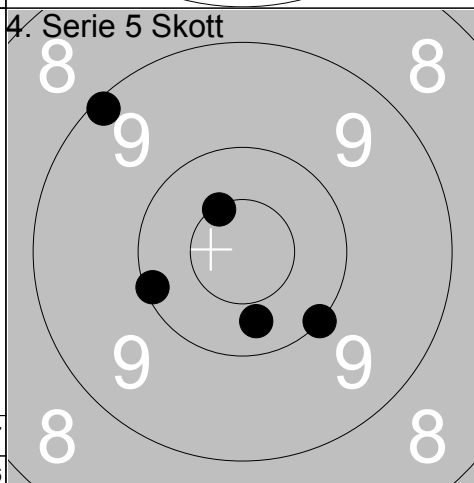

1:	9.1	↗
2:	10.1	←
3:	10.0	↘
4:	10.5x	↗
5:	10.3	↘
Serie		49
Total		175

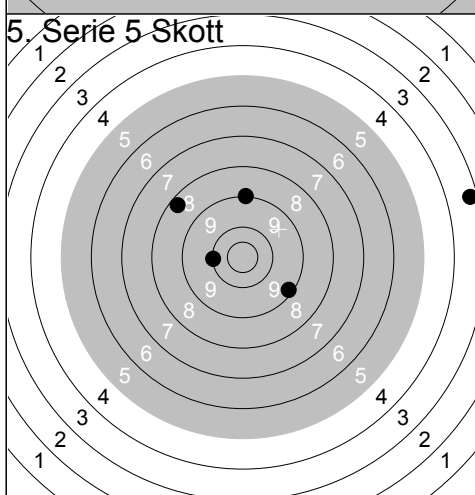

1:	10.0	←
2:	9.0	↑
3:	9.2	↘
4:	3.2	→
5:	8.3	↗
Serie		39
Total		214

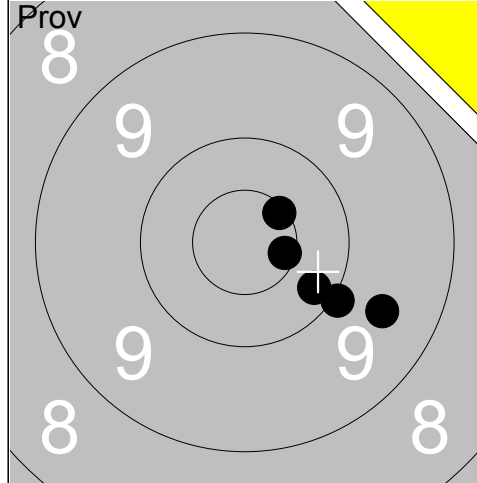

1:	9.6	→
2:	10.2	→
3:	10.6x	→
4:	10.5x	↗
5:	10.0	→

Serie	49
Total	0

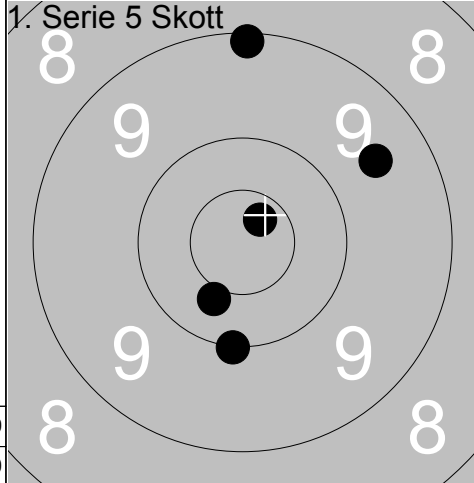

1:	9.5	↗
2:	10.4	↘
3:	9.1	↑
4:	10.0	↘
5:	10.7x	↗

Serie	48
Total	48

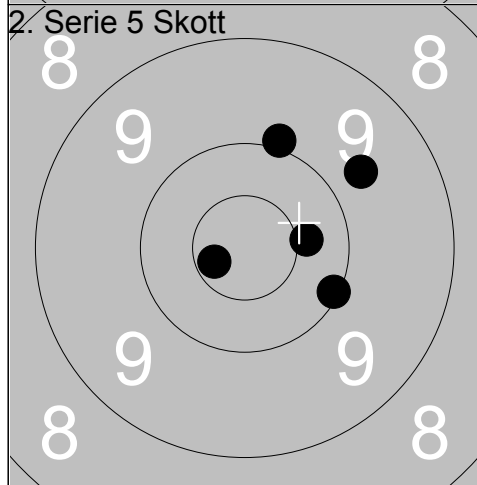

1:	10.4	→
2:	10.7x	←
3:	10.0	↑
4:	9.7	↗
5:	10.1	→

Serie	49
Total	97

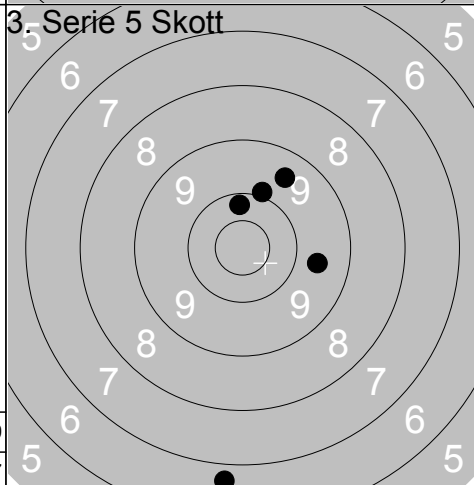

1:	10.2	↑
2:	9.9	↑
3:	9.6	→
4:	6.7	↓
5:	9.5	↗

Serie	43
Total	140

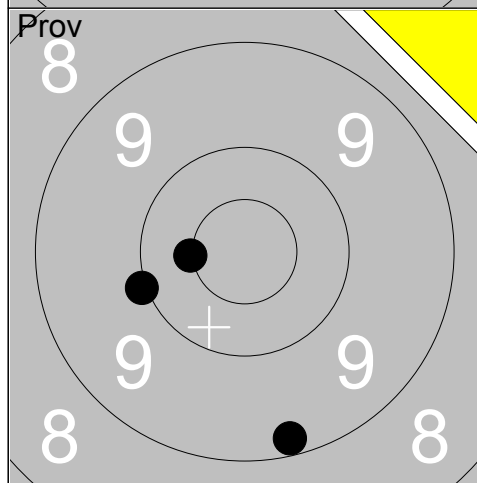

1:	9.2	↓
2:	10.5x	←
3:	10.0	←

Serie	29
Total	140

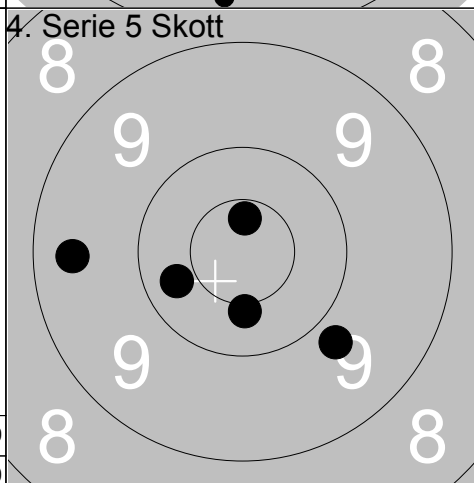

1:	10.4x	↓
2:	9.8	↘
3:	9.4	←
4:	10.3	←
5:	10.7x	↑

Serie	48
Total	188

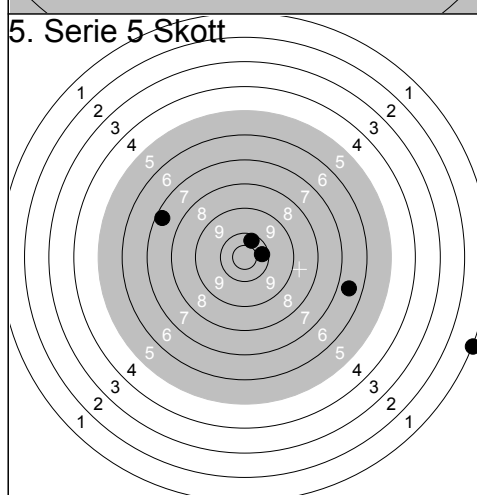

1:	7.3	↖
2:	10.3	→
3:	10.3	↗
4:	1.0	→
5:	6.6	→

Serie	34
Total	222

<p><b>Prov</b></p>	<p>1: 10.0 ↘ 2: 9.4 → 3: 10.0 ↘ 4: 9.7 ↗ 5: 10.1 ↘</p> <p>Serie 48 Total 0</p>	<p><b>1. Serie 5 Skott</b></p>	<p>1: 10.3 ← 2: 9.8 → 3: 9.8 ↘ 4: 10.4 ↗ 5: 8.7 ←</p> <p>Serie 46 Total 46</p>
<p><b>2. Serie 5 Skott</b></p>	<p>1: 9.4 ↘ 2: 10.7x ↗ 3: 10.0 ↗ 4: 9.9 ← 5: 9.9 ↘</p> <p>Serie 47 Total 93</p>	<p><b>3. Serie 5 Skott</b></p>	<p>1: 8.4 ↑ 2: 10.2 ← 3: 7.9 ↘ 4: 9.1 ↗ 5: 2.3 ↘</p> <p>Serie 36 Total 129</p>
<p><b>Prov</b></p>	<p>1: 9.3 ← 2: 9.7 → 3: 10.2 ↑</p> <p>Serie 28 Total 129</p>	<p><b>4. Serie 5 Skott</b></p>	<p>1: 10.1 ↘ 2: 10.1 ← 3: 9.8 ← 4: 9.4 ↗ 5: 10.9x ↘</p> <p>Serie 48 Total 177</p>
<p><b>5. Serie 5 Skott</b></p>	<p>1: 7.9 ↗ 2: 8.7 ↘ 3: 9.7 ↗ 4: 7.1 ↗ 5: 8.2 ←</p> <p>Serie 39 Total 216</p>		

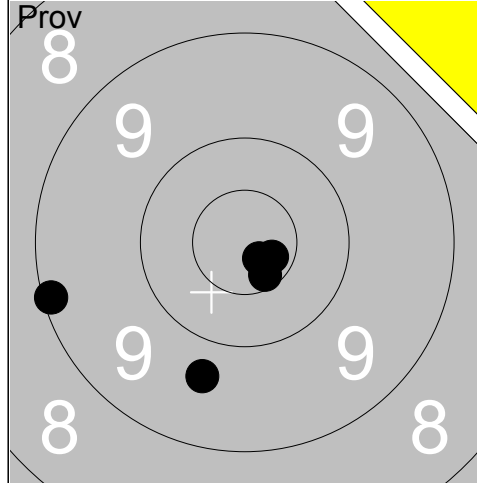

1:	9.1	←
2:	9.7	↓
3:	10.8x	↓
4:	10.6x	↓
5:	10.7x	→
Serie		48
Total		0

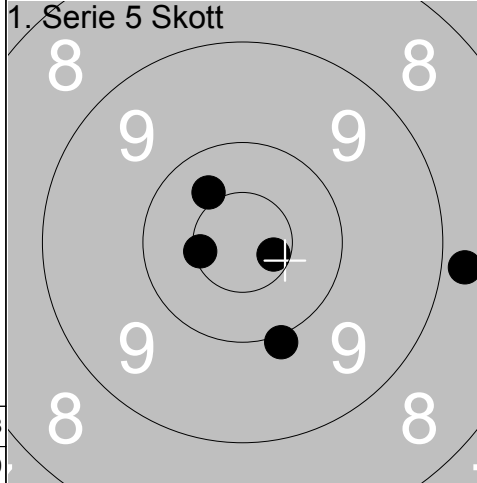

1:	10.5x	←
2:	10.0	↓
3:	8.8	→
4:	10.6x	→
5:	10.4	↗
Serie		48
Total		48

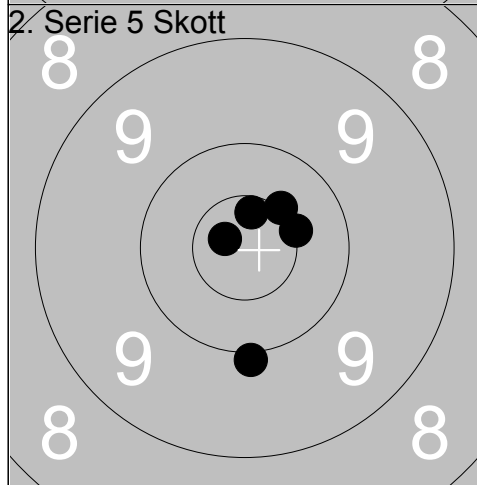

1:	10.0	↓
2:	10.6x	↑
3:	10.8x	←
4:	10.5x	↗
5:	10.5x	→
Serie		50
Total		98

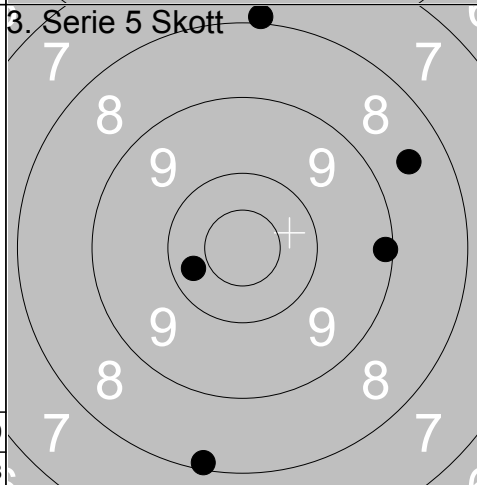

1:	9.1	→
2:	8.1	↓
3:	10.3	←
4:	7.9	↑
5:	8.5	↗
Serie		42
Total		140

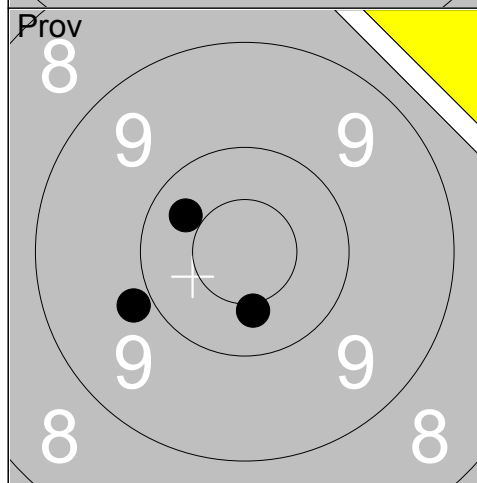

1:	10.4x	↓
2:	9.9	←
3:	10.3	↖
Serie		29
Total		140

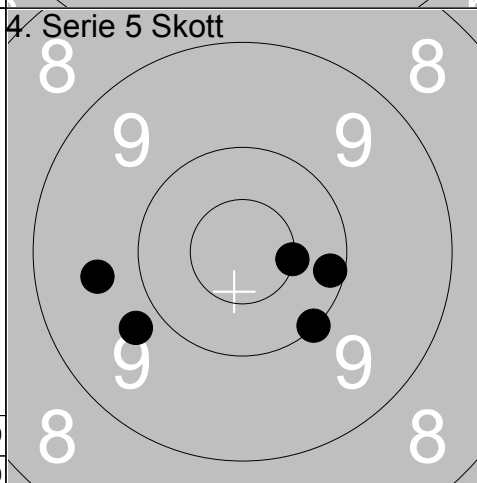

1:	9.8	←
2:	10.2	→
3:	9.6	←
4:	10.5x	→
5:	10.0	↓
Serie		48
Total		188

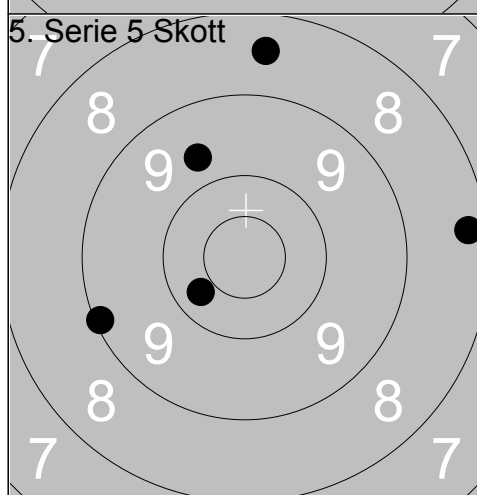

1:	10.3	←
2:	9.1	←
3:	9.7	↗
4:	8.3	→
5:	8.5	↑
Serie		44
Total		232

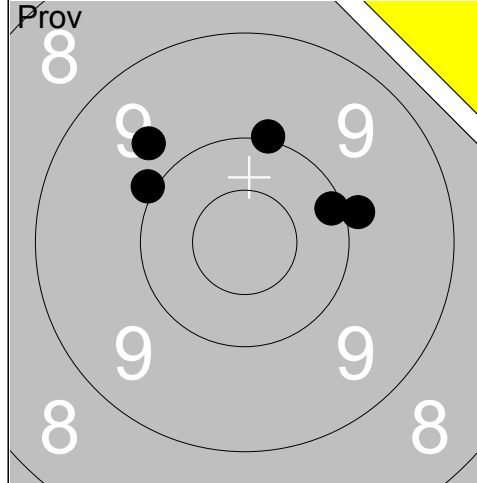

1:	9.9	→
2:	10.0	↖
3:	10.1	→
4:	9.7	↖
5:	10.0	↑
Serie		48
Total		0

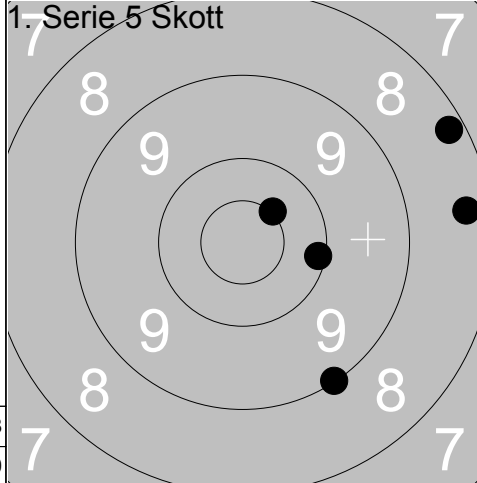

1:	10.5x	↗
2:	8.3	→
3:	8.2	↗
4:	9.0	↘
5:	10.1	→
Serie		45
Total		45

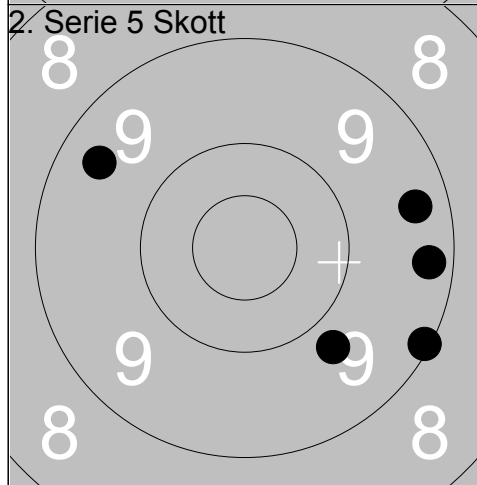

1:	9.8	↘
2:	9.4	↗
3:	9.4	→
4:	9.1	↘
5:	9.3	→
Serie		45
Total		90

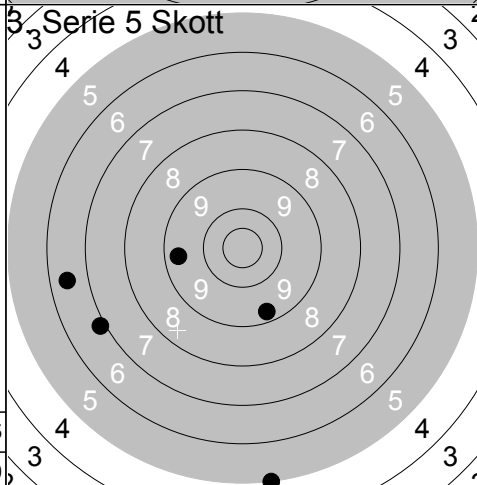

1:	9.3	↘
2:	6.5	←
3:	9.4	←
4:	5.0	↘
5:	6.9	↖
Serie		35
Total		125

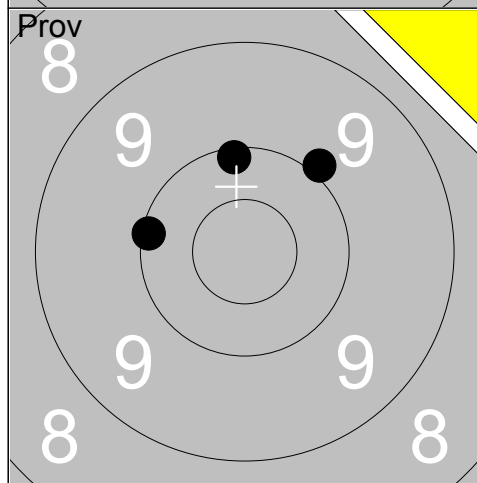

1:	10.1	←
2:	10.1	↑
3:	9.9	↗
Serie		29
Total		125

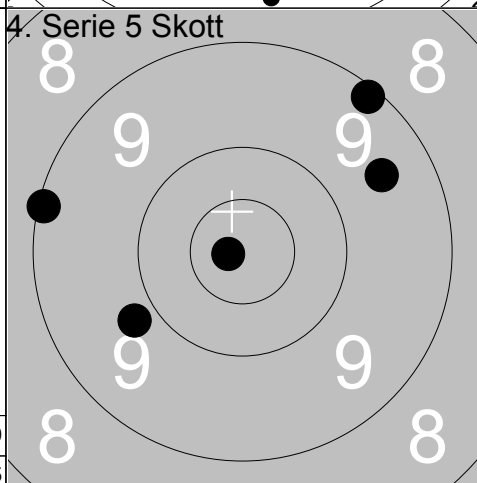

1:	9.1	←
2:	10.8x	←
3:	9.1	↗
4:	9.8	↖
5:	9.5	↗
Serie		46
Total		171

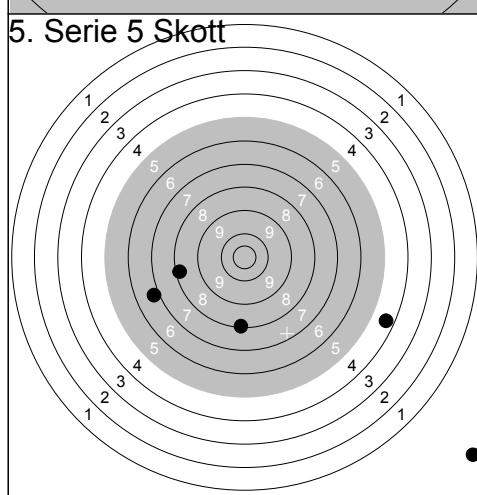

1:	8.1	↘
2:	4.4	→
3:	8.2	←
4:	0.0	↘
5:	6.8	←
Serie		26
Total		197

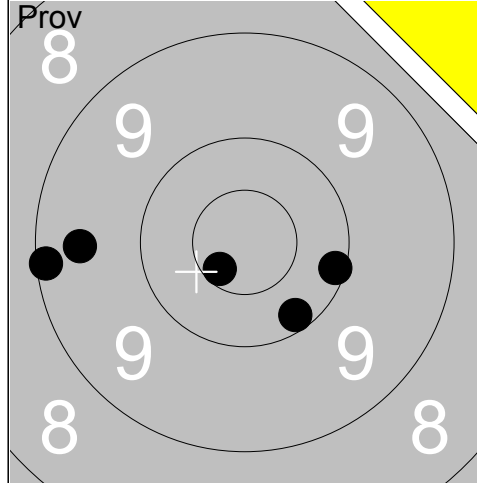

1:	9.1	←
2:	10.6x	↙
3:	9.5	←
4:	10.2	↘
5:	10.1	→

Serie	48
Total	0

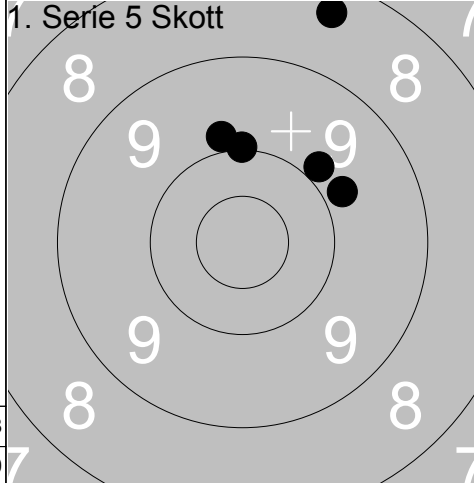

1:	9.9	↗
2:	8.4	↑
3:	9.8	→
4:	10.0	↑
5:	9.9	↑

Serie	45
Total	45

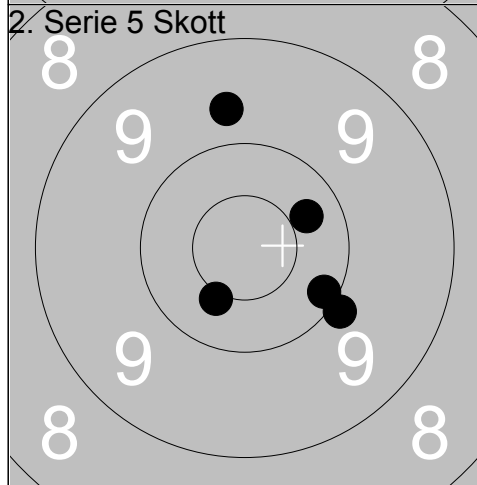

1:	9.9	↘
2:	10.1	↘
3:	10.4x	↙
4:	9.7	↑
5:	10.3	→

Serie	48
Total	93

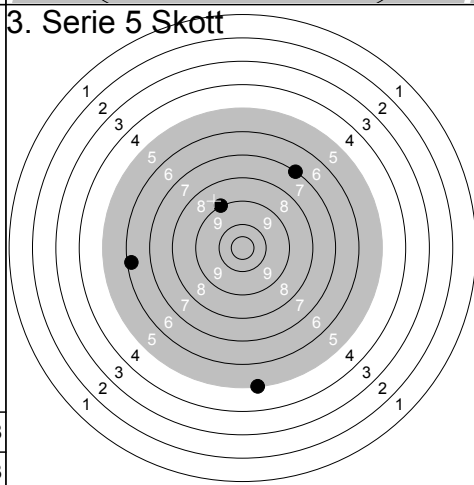

1:	7.0	↗
2:	9.0	↖
3:	6.2	←
4:	5.1	↓
5:	0.0	↑

Serie	27
Total	120

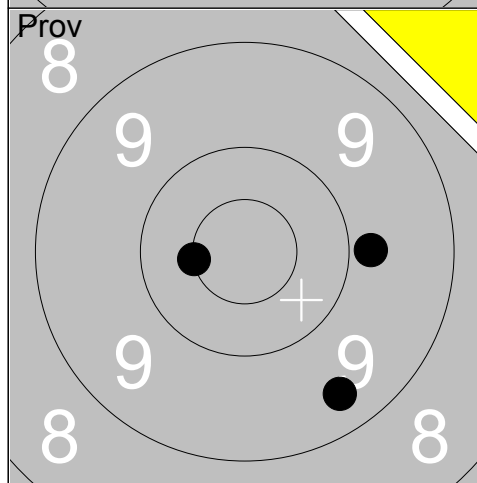

1:	9.8	→
2:	10.5x	←
3:	9.4	↘

Serie	28
Total	120

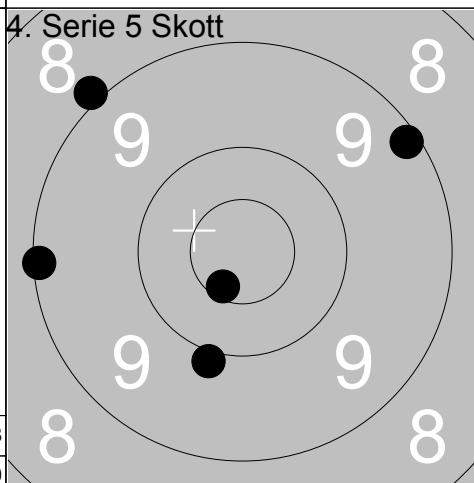

1:	8.9	↖
2:	10.6x	↘
3:	9.1	↗
4:	9.1	←
5:	9.9	↓

Serie	45
Total	165

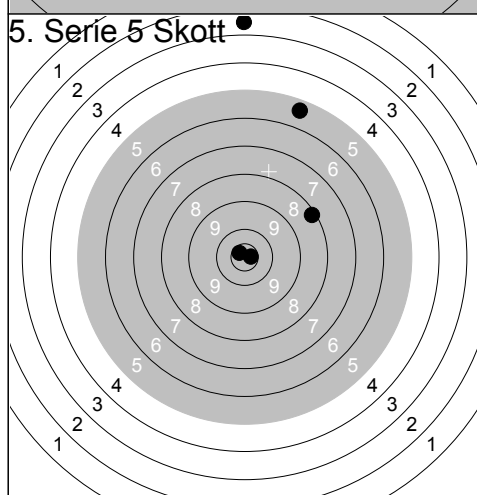

1:	5.4	↑
2:	10.7x	↖
3:	8.2	↗
4:	10.7x	→
5:	2.6	↑

Serie	35
Total	200

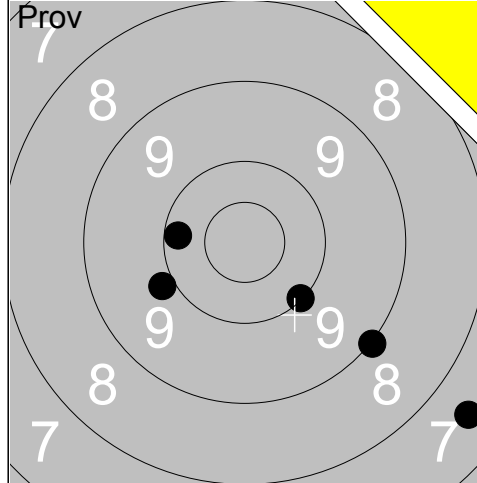

1:	7.5	↘
2:	9.0	↘
3:	10.2	←
4:	9.9	↙
5:	10.0	↘
Serie		45
Total		0

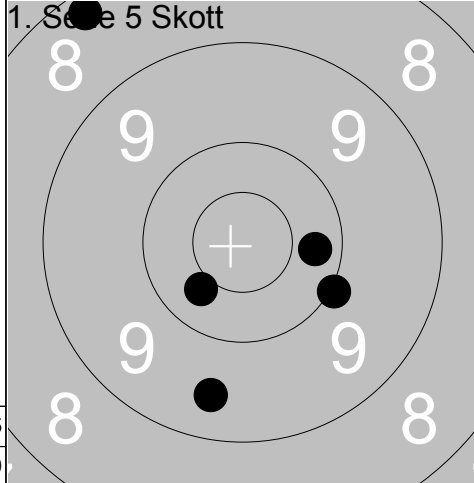

1:	10.4	↙
2:	9.5	↘
3:	10.3	→
4:	8.3	↗
5:	10.0	↘
Serie		47
Total		47

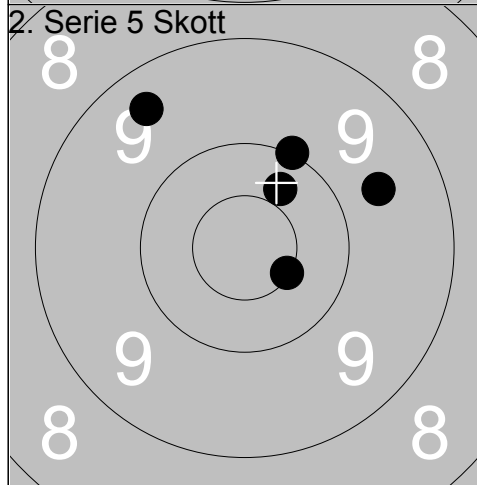

1:	10.5x	↘
2:	9.6	→
3:	9.4	↗
4:	10.0	↗
5:	10.3	↗
Serie		48
Total		95

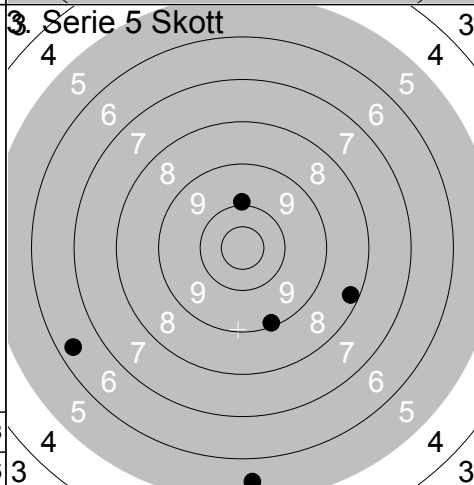

1:	9.1	↘
2:	9.9	↑
3:	5.5	↘
4:	6.4	↙
5:	8.2	→
Serie		37
Total		132

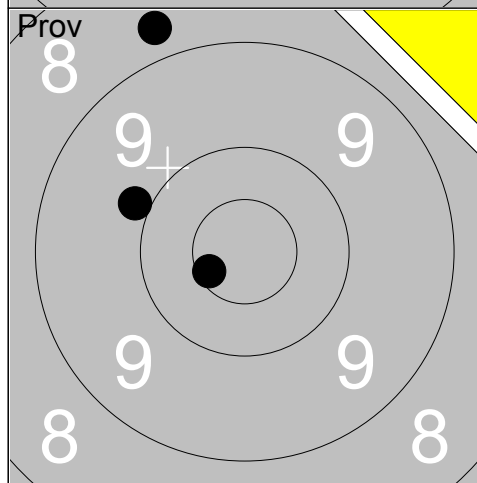

1:	10.6x	↙
2:	9.9	↙
3:	8.7	↗
Serie		27
Total		132

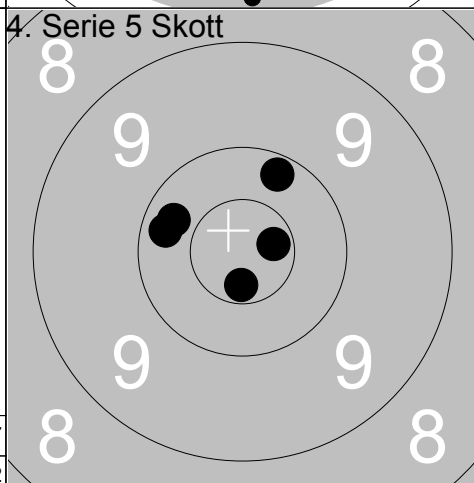

1:	10.2	↙
2:	10.7x	→
3:	10.7x	↘
4:	10.3	↙
5:	10.2	↗
Serie		50
Total		182

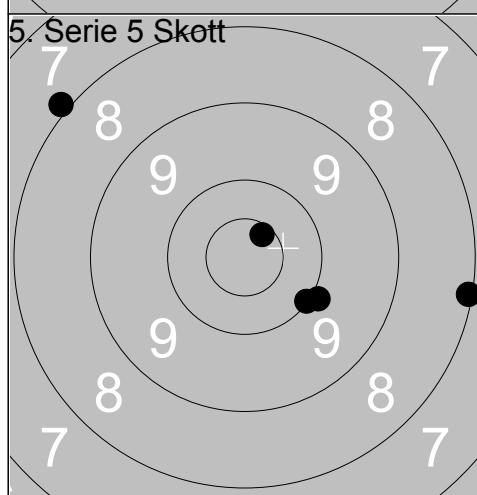

1:	10.0	↘
2:	9.9	↘
3:	10.6x	↗
4:	8.1	→
5:	7.9	↗
Serie		44
Total		226



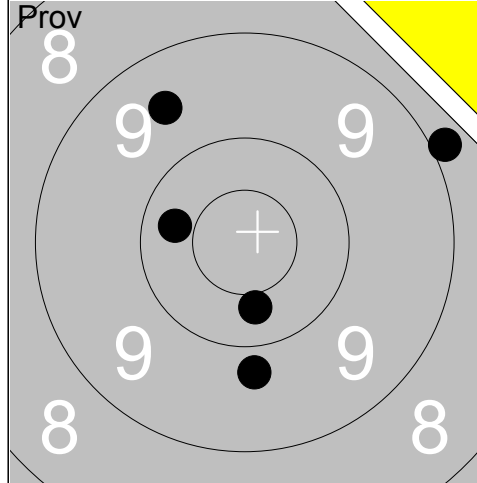

1:	9.5	↗
2:	8.9	→
3:	10.4	↓
4:	10.3	←
5:	9.8	↓
Serie		46
Total		0

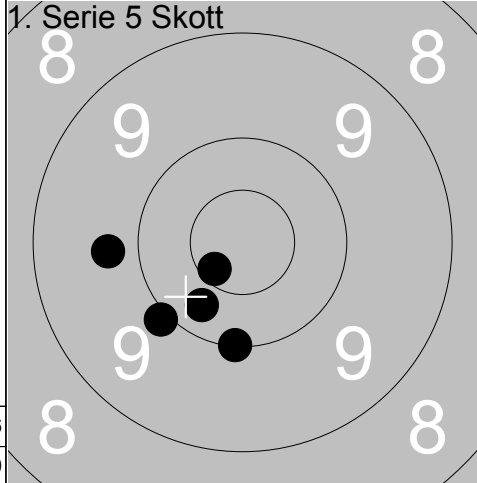

1:	10.6x	↙
2:	10.3	↘
3:	10.0	↓
4:	10.0	↙
5:	9.7	←
Serie		49
Total		49

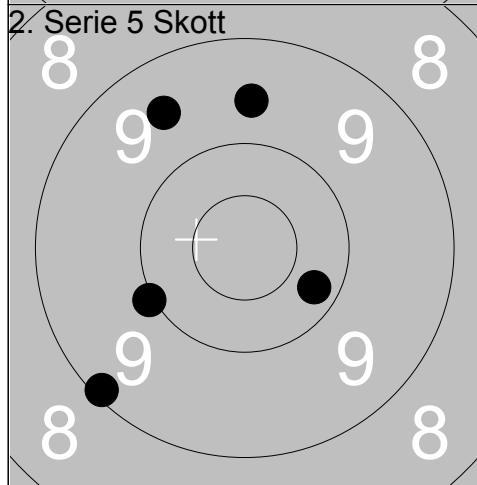

1:	9.6	↑
2:	10.0	↙
3:	9.1	↘
4:	9.5	↑
5:	10.2	↘
Serie		47
Total		96

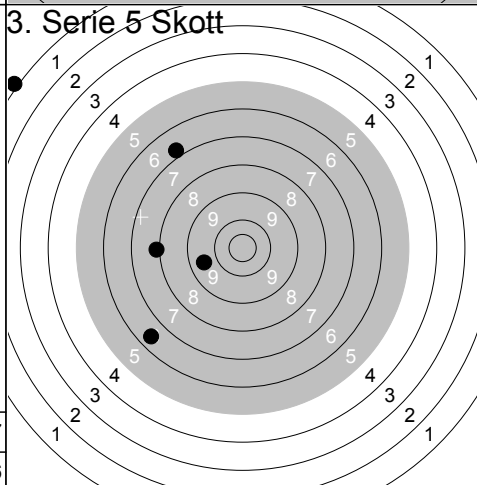

1:	9.5	←
2:	6.4	↘
3:	7.9	←
4:	0.0	↗
5:	6.8	↗
Serie		28
Total		124

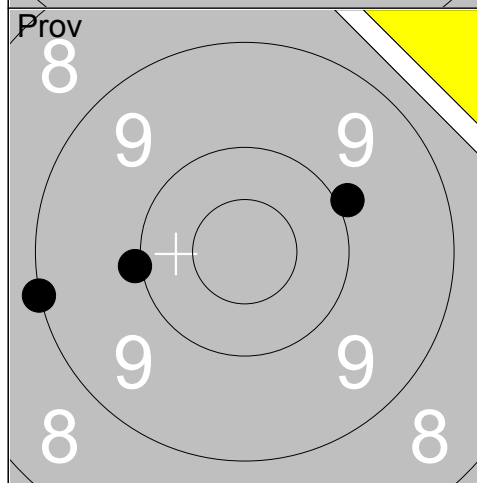

1:	9.0	←
2:	9.9	→
3:	10.0	←
Serie		28
Total		124

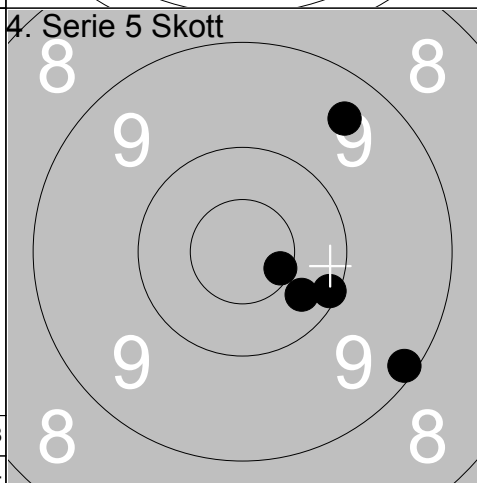

1:	10.6x	→
2:	10.3	↘
3:	9.4	↗
4:	10.1	→
5:	9.1	↘
Serie		48
Total		172

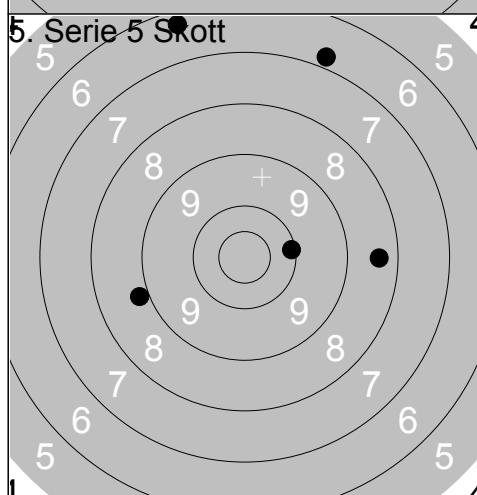

1:	10.1	→
2:	8.8	←
3:	8.4	→
4:	6.8	↗
5:	6.3	↗
Serie		38
Total		210

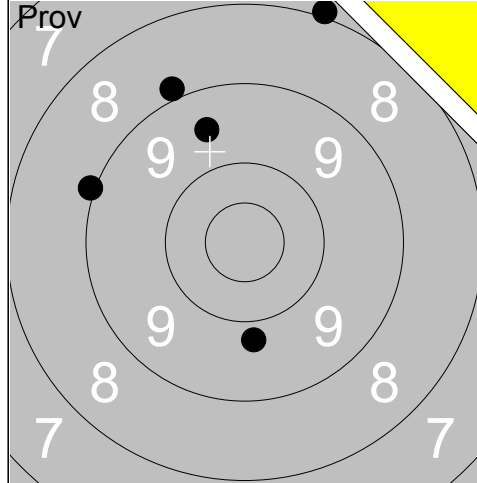

1:	9.8	↘
2:	8.9	↗
3:	9.0	↗
4:	8.0	↗
5:	9.5	↗
Serie		43
Total		0

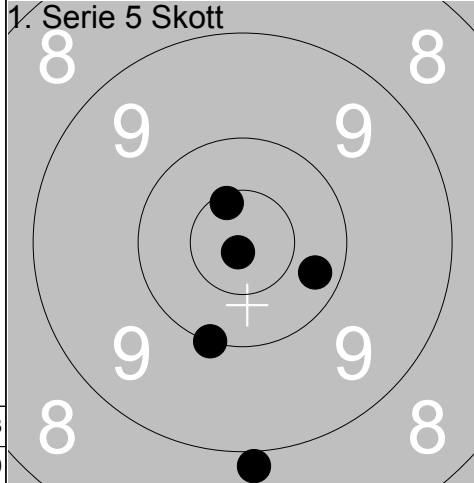

1:	10.9x	↘
2:	8.9	↘
3:	10.0	↘
4:	10.6x	↗
5:	10.3	↗
Serie		48
Total		48

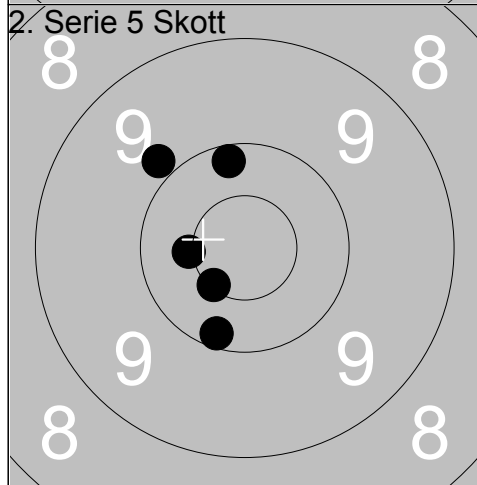

1:	10.2	↗
2:	10.5x	←
3:	9.9	↗
4:	10.5x	↘
5:	10.2	↘
Serie		49
Total		97

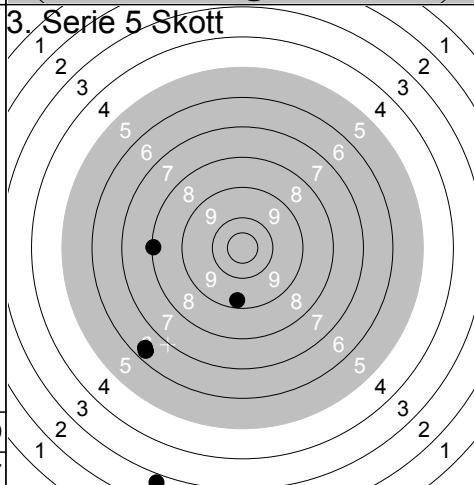

1:	6.3	↘
2:	8.1	←
3:	6.4	↘
4:	9.3	↘
5:	2.7	↘
Serie		31
Total		128

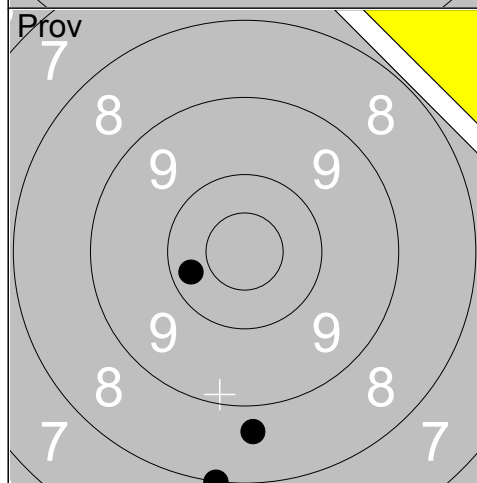

1:	8.0	↘
2:	8.7	↘
3:	10.3	←
Serie		26
Total		128

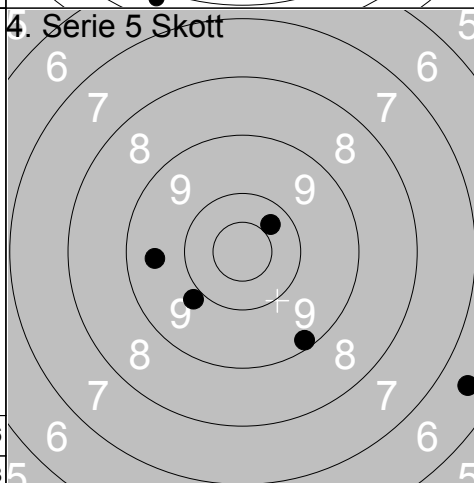

1:	9.2	↘
2:	9.5	←
3:	10.3	↗
4:	6.5	↘
5:	9.9	↘
Serie		43
Total		171

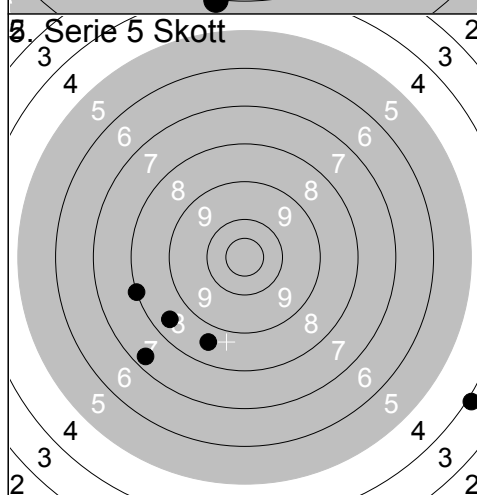

1:	7.3	↘
2:	8.0	←
3:	8.6	↘
4:	8.5	↘
5:	3.9	↘
Serie		34
Total		205

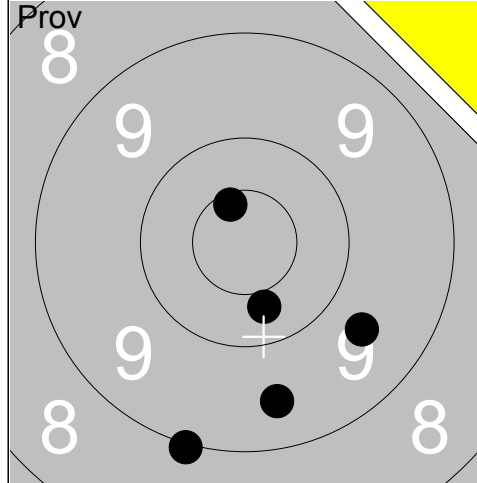

1:	9.6	↘
2:	9.0	↓
3:	9.5	↓
4:	10.6x	↗
5:	10.4	↓
Serie		47
Total		0

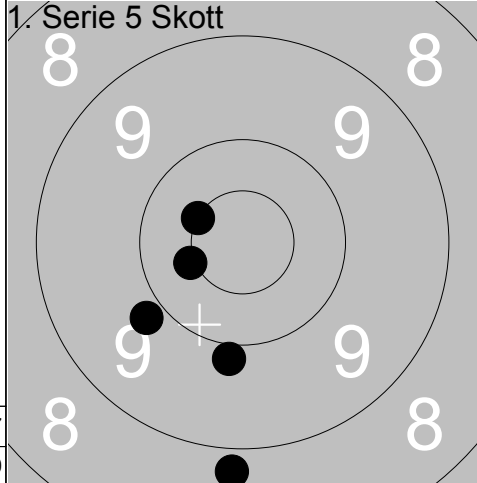

1:	10.5x	↖
2:	10.4x	↖
3:	9.8	↖
4:	8.8	↓
5:	9.9	↓
Serie		46
Total		46

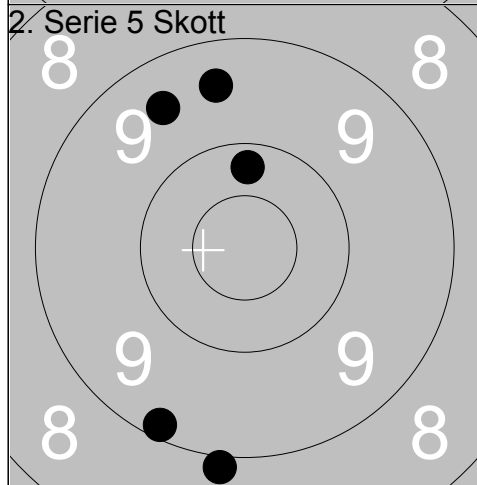

1:	9.5	↗
2:	8.9	↓
3:	9.2	↓
4:	9.5	↗
5:	10.2	↗
Serie		45
Total		91

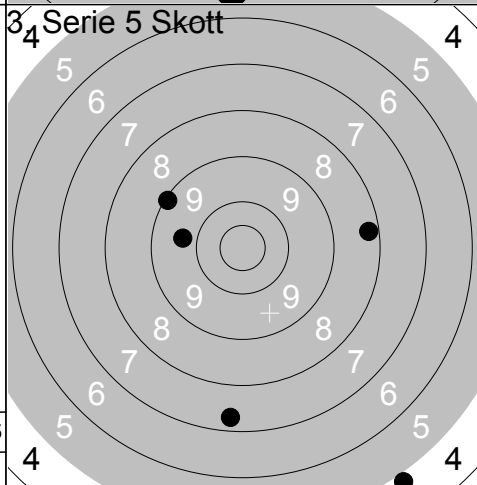

1:	9.7	↖
2:	9.1	↗
3:	8.2	→
4:	4.9	↓
5:	7.3	↓
Serie		37
Total		128

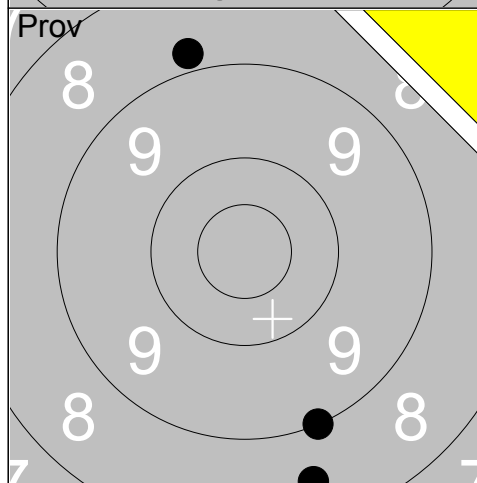

1:	8.8	↗
2:	9.0	↓
3:	8.5	↓
Serie		25
Total		128

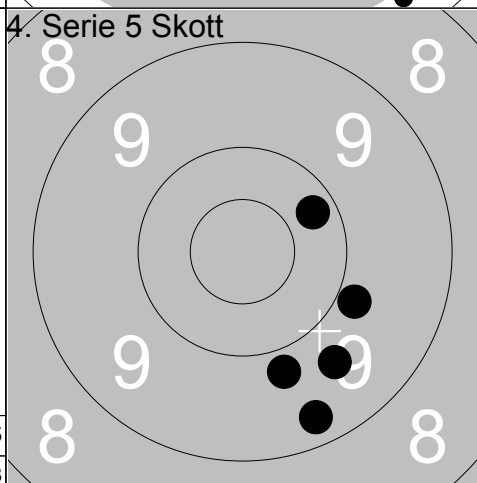

1:	10.2	↗
2:	9.8	↓
3:	9.7	↓
4:	9.9	→
5:	9.3	↓
Serie		46
Total		174

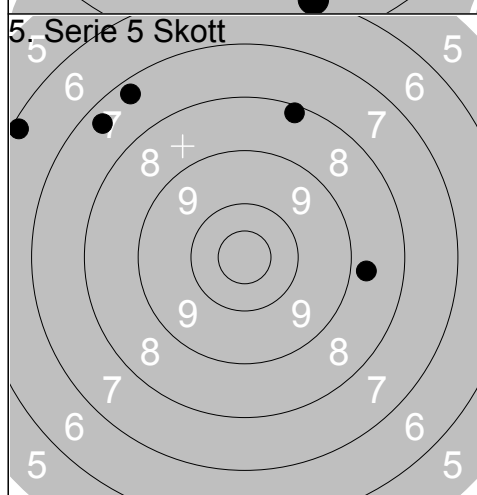

1:	8.7	→
2:	7.3	↗
3:	8.2	↗
4:	6.2	↗
5:	7.4	↗
Serie		36
Total		210

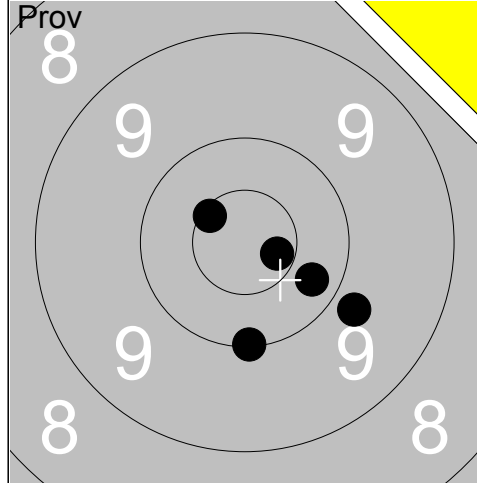

1:	9.8	↘
2:	10.6x	↗
3:	10.3	↘
4:	10.6x	↘
5:	10.0	↓
Serie		49
Total		0

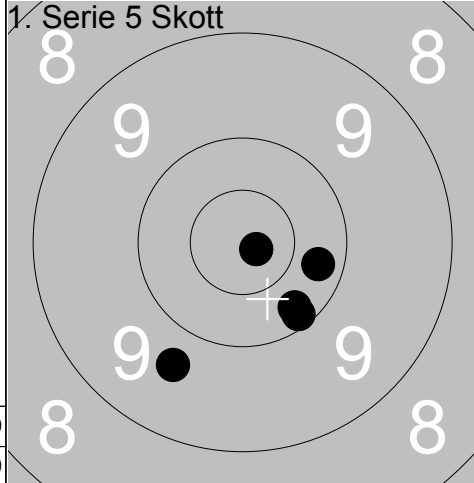

1:	10.3	↘
2:	10.1	↘
3:	9.7	↘
4:	10.2	↘
5:	10.8x	↘
Serie		49
Total		49

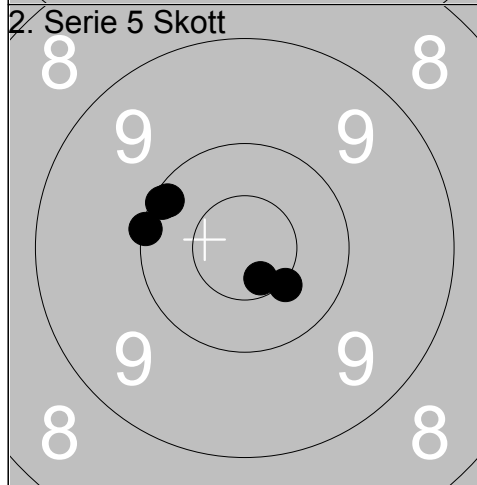

1:	10.6x	↘
2:	10.1	↗
3:	10.1	↗
4:	10.5x	↘
5:	10.1	←
Serie		50
Total		99

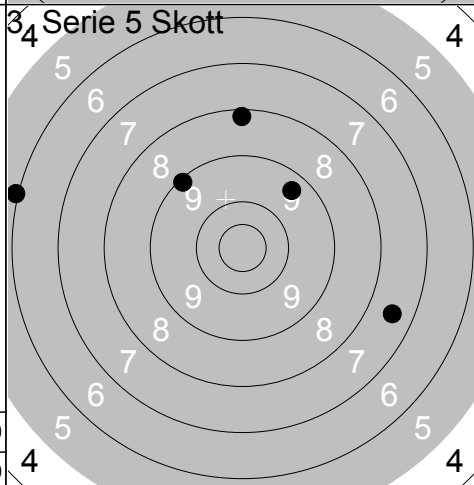

1:	9.4	↗
2:	9.1	↗
3:	8.2	↑
4:	6.0	←
5:	7.5	↘
Serie		39
Total		138

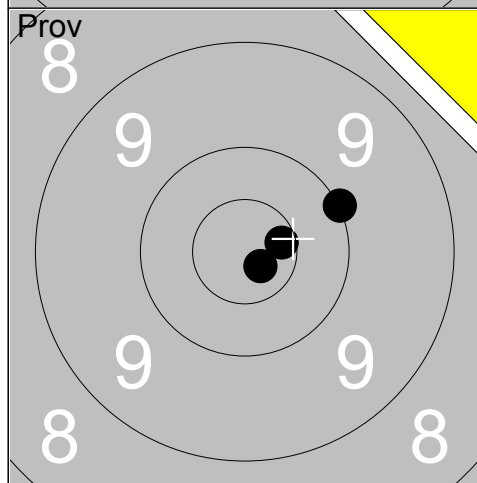

1:	10.6x	→
2:	10.0	→
3:	10.8x	↘
Serie		30
Total		138

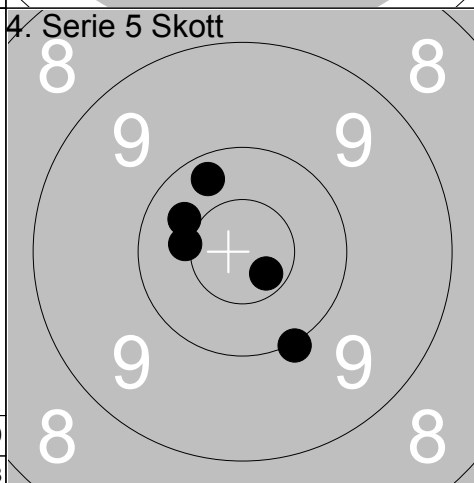

1:	10.7x	↘
2:	10.4x	←
3:	10.4	↗
4:	10.2	↗
5:	10.0	↘
Serie		50
Total		188

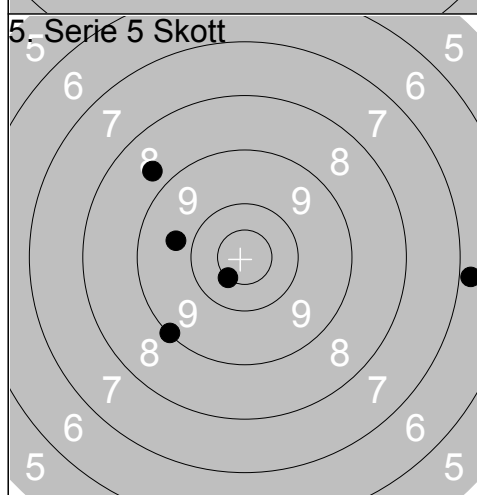

1:	10.5x	↘
2:	8.7	↗
3:	9.7	←
4:	6.8	→
5:	9.0	↘
Serie		42
Total		230

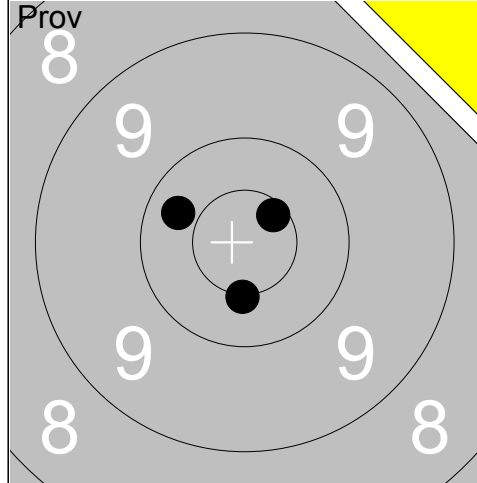

1:	10.6x	↗
2:	10.3	↖
3:	10.5x	↓
<b>Serie</b>		<b>30</b>
<b>Total</b>		<b>0</b>

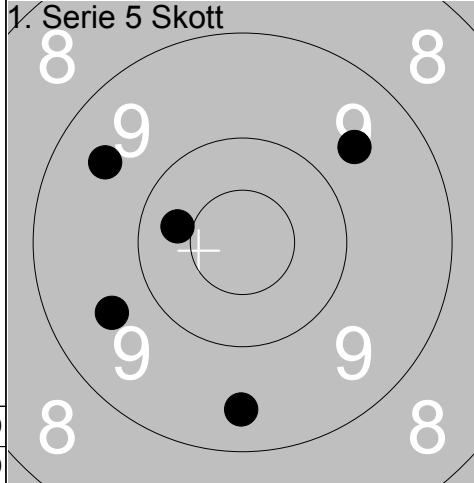

1:	9.6	↗
2:	9.6	↖
3:	9.5	↖
4:	9.4	↓
5:	10.4	↖
<b>Serie</b>		<b>46</b>
<b>Total</b>		<b>46</b>

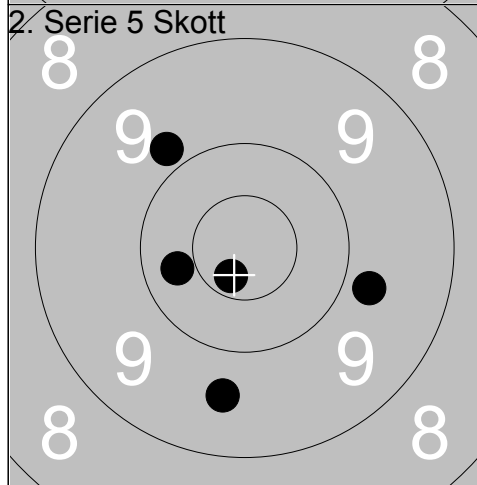

1:	10.3	↖
2:	9.8	↗
3:	9.8	→
4:	10.7x	↘
5:	9.6	↓
<b>Serie</b>		<b>47</b>
<b>Total</b>		<b>93</b>

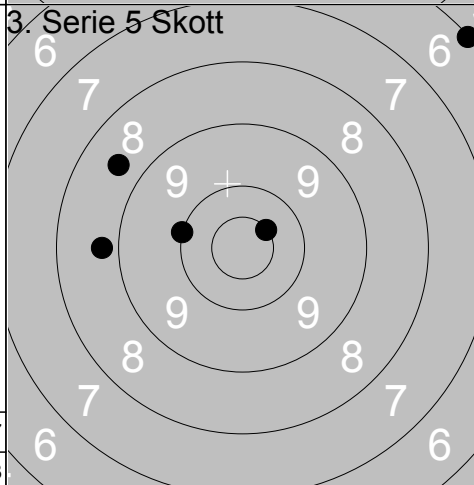

1:	10.0	↖
2:	10.5x	↗
3:	8.6	↖
4:	8.8	↖
5:	6.0	↗
<b>Serie</b>		<b>42</b>
<b>Total</b>		<b>135</b>

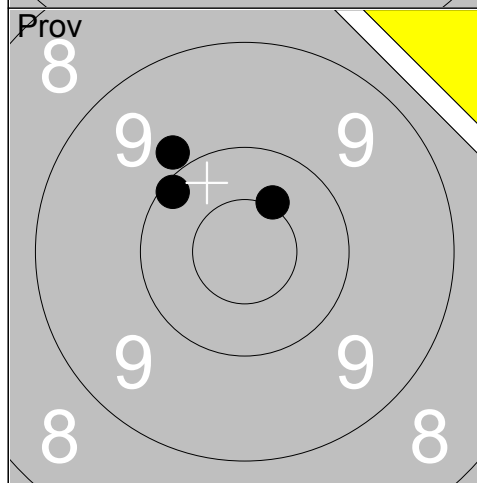

1:	9.9	↗
2:	10.4x	↗
3:	10.1	↗
<b>Serie</b>		<b>29</b>
<b>Total</b>		<b>135</b>

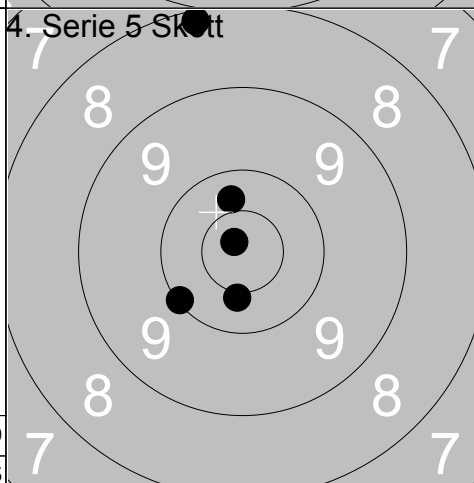

1:	8.2	↑
2:	10.1	↖
3:	10.4x	↓
4:	10.3	↑
5:	10.8x	↖
<b>Serie</b>		<b>48</b>
<b>Total</b>		<b>183</b>

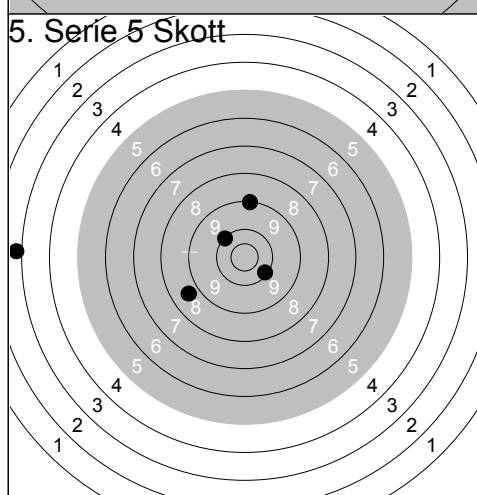

1:	8.6	↖
2:	10.0	↗
3:	9.0	↑
4:	2.8	↖
5:	10.1	↘
<b>Serie</b>		<b>39</b>
<b>Total</b>		<b>222</b>

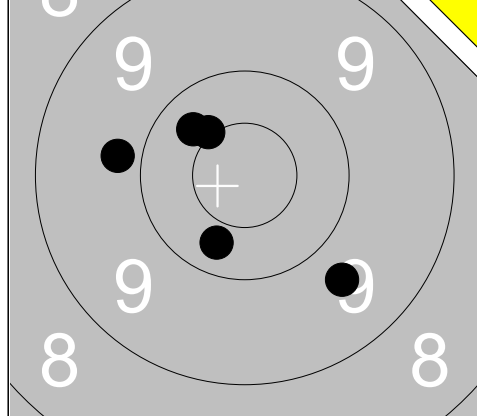

1:	10.3	↗
2:	10.3	↘
3:	10.4x	↗
4:	9.8	↖
5:	9.7	↘
Serie		48
Total		0

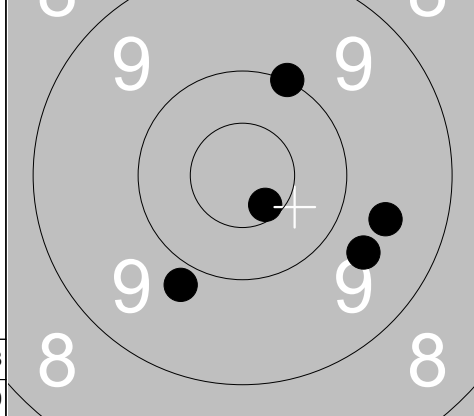

1:	10.6x	↘
2:	9.8	↘
3:	9.7	↘
4:	9.6	→
5:	10.0	↗
Serie		47
Total		47

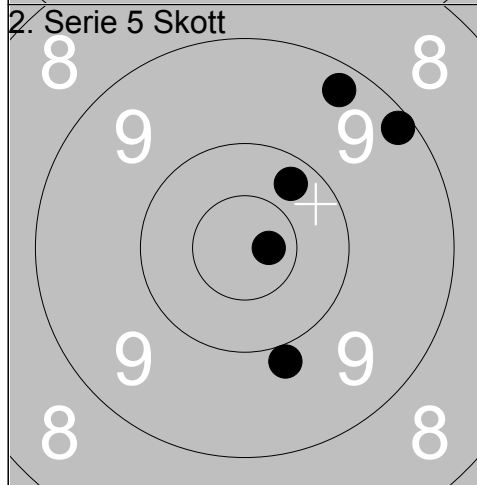

1:	9.9	↘
2:	9.3	↗
3:	9.2	↗
4:	10.2	↗
5:	10.7x	→
Serie		47
Total		94

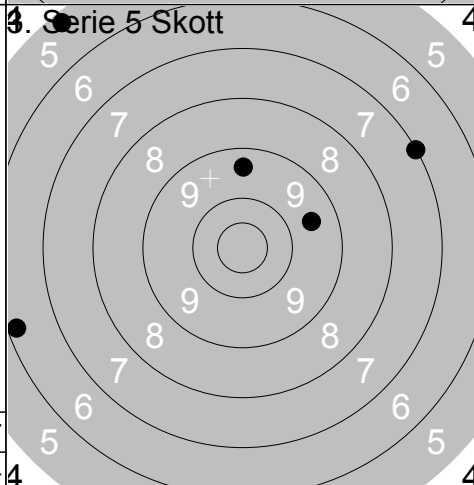

1:	9.6	→
2:	9.4	↑
3:	6.2	↖
4:	5.2	↖
5:	7.0	↗
Serie		36
Total		130

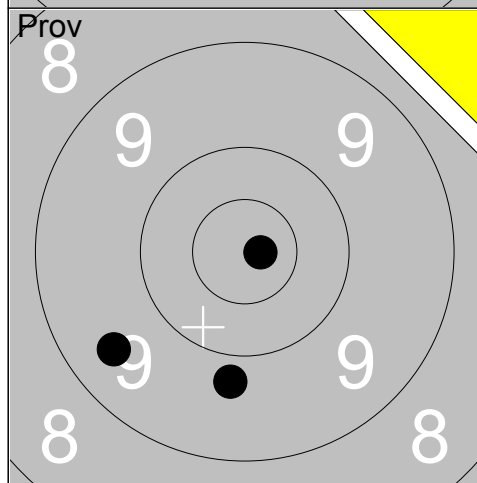

1:	10.8x	→
2:	9.5	↖
3:	9.8	↘
Serie		28
Total		130

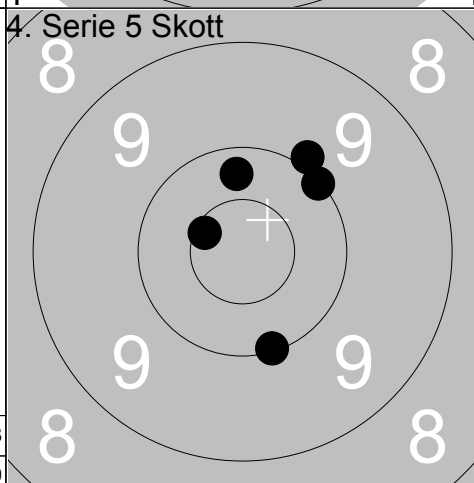

1:	10.1	↘
2:	9.9	↗
3:	10.3	↑
4:	10.0	↗
5:	10.6x	↖
Serie		49
Total		179

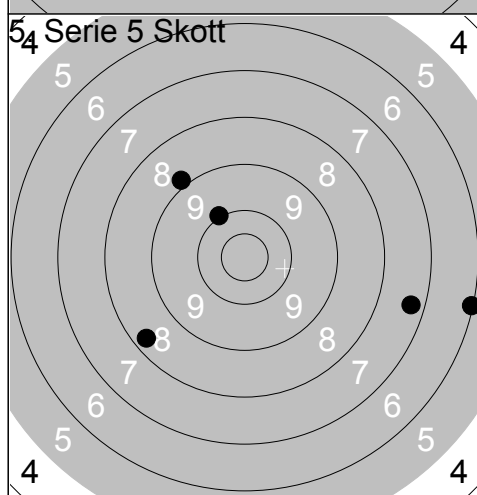

1:	6.1	→
2:	7.3	↘
3:	10.0	↗
4:	8.9	↗
5:	8.3	↖
Serie		39
Total		218

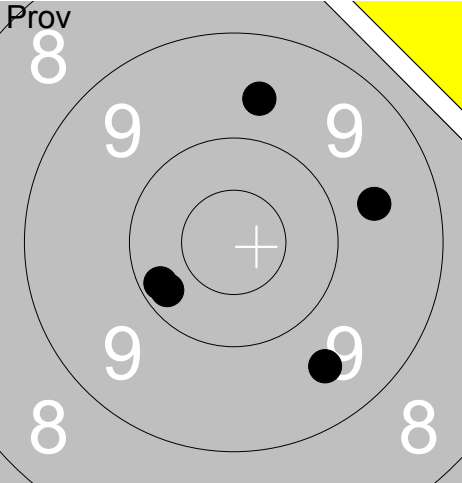
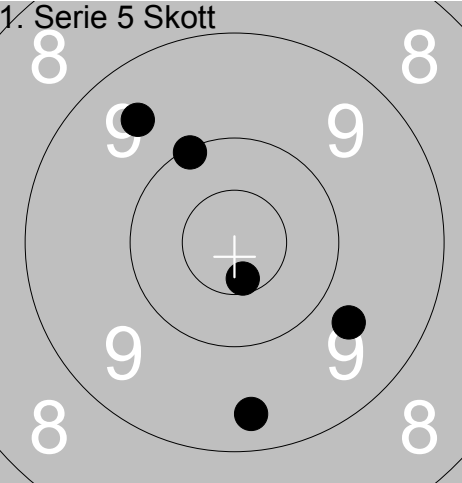
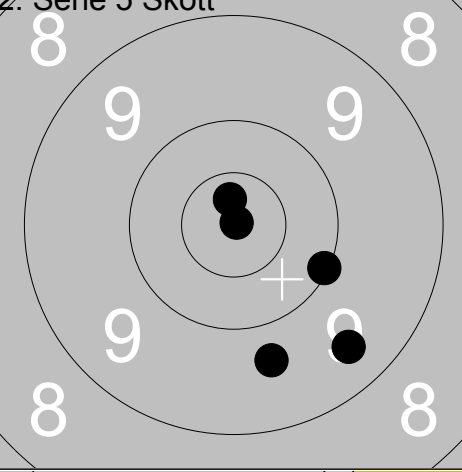
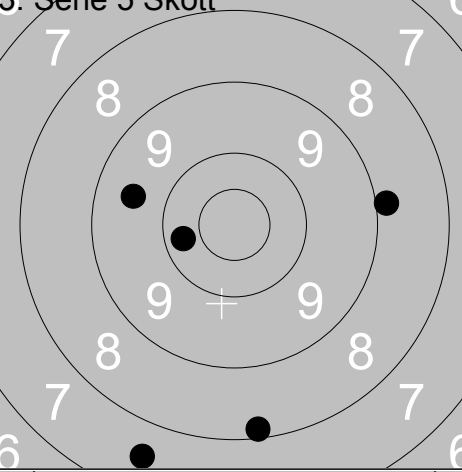
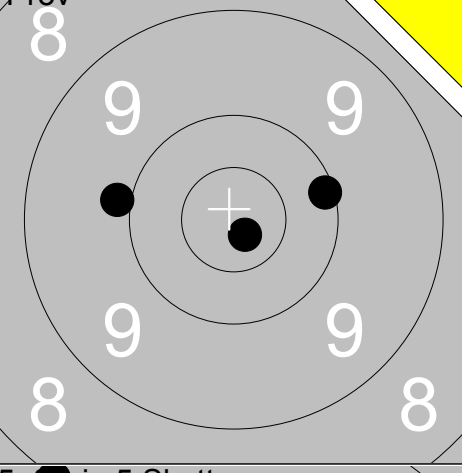
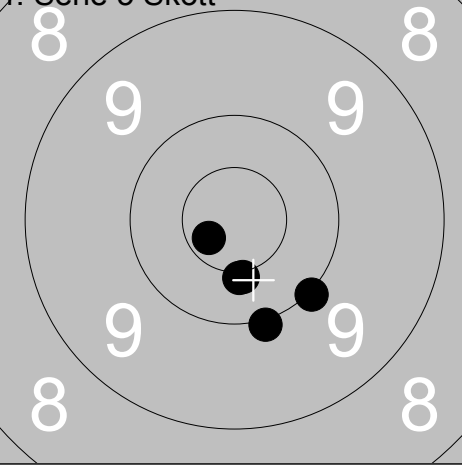
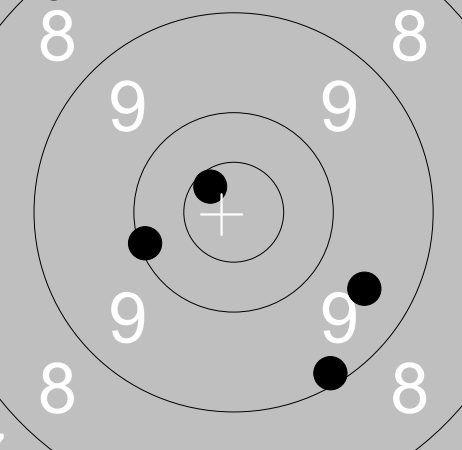
Skjutlag <b>3</b>	Tavla <b>6</b>	<b>Caroline Törnvall</b>			
Ramselefors		Ultuna		Öpp	Up
13.08.2017		SM Banskytte Ställning 2017		Ramselefors SKF	
Prov 	1: 10.2 ↙ 2: 10.2 ↙ 3: 9.6 → 4: 9.6 ↑ 5: 9.6 ↓	1. Serie 5 Skott 	1: 9.5 ↗ 2: 9.4 ↓ 3: 10.1 ↗ 4: 10.6x ↓ 5: 9.7 ↓	Serie 47	Total 0
2. Serie 5 Skott 	1: 9.7 ↓ 2: 10.7x ↑ 3: 10.9x ↗ 4: 10.1 ↘ 5: 9.4 ↓	3. Serie 5 Skott 	1: 9.6 ← 2: 10.3 ← 3: 8.9 → 4: 8.2 ↓ 5: 7.6 ↓	Serie 48	Total 95
Prov 	1: 9.9 ← 2: 10.8x ↓ 3: 10.1 →	4. Serie 5 Skott 	1: 10.4x ↓ 2: 10.4x ↓ 3: 10.7x ↙ 4: 10.0 ↓ 5: 10.0 ↓	Serie 29	Total 137
5. Serie 5 Skott 	1: 10.6x ↗ 2: 10.1 ← 3: 9.1 ↓ 4: 8.1 ↗ 5: 9.5 ↓			Serie 46	Total 233

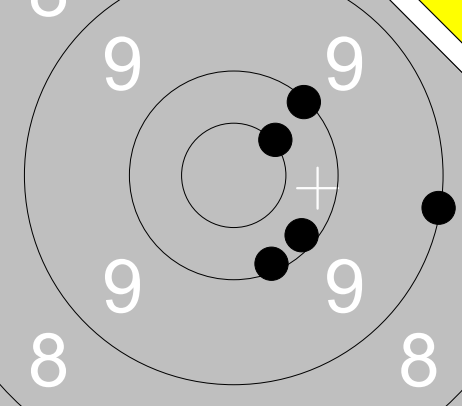
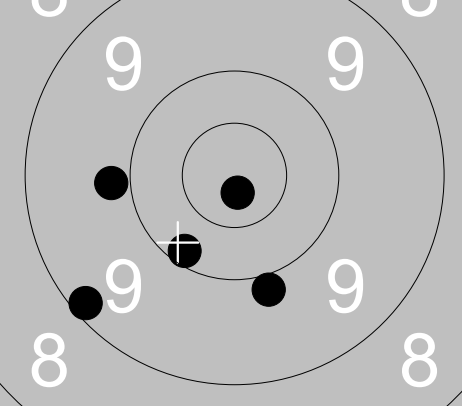
<p><b>Prov</b></p> 	<p>1: 10.0 ↗ 2: 9.0 → 3: 10.5x ↗ 4: 10.1 ↘ 5: 10.1 ↘</p>	<p><b>1. Serie 5 Skott</b></p> 	<p>1: 9.8 ← 2: 10.8x ↓ 3: 9.9 ↓ 4: 9.2 ↙ 5: 10.1 ↘</p>
Serie 49		Serie 47	
Total 0		Total 47	

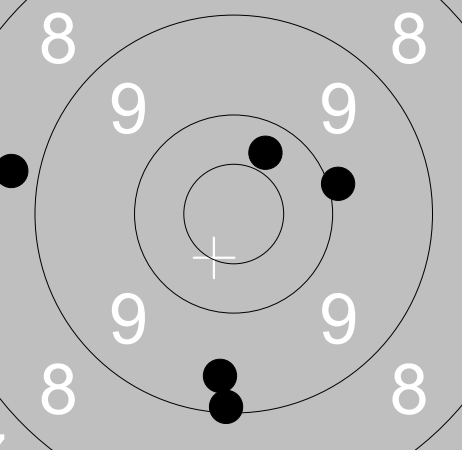
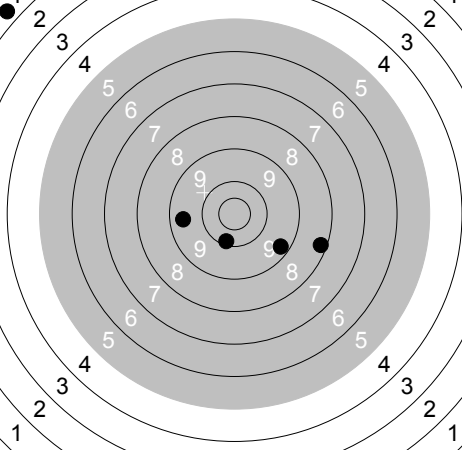
<p><b>2. Serie 5 Skott</b></p> 	<p>1: 9.9 → 2: 9.1 ↓ 3: 8.8 ← 4: 10.3 ↗ 5: 9.4 ↓</p>	<p><b>3. Serie 5 Skott</b></p> 	<p>1: 9.4 ← 2: 9.3 ↘ 3: 10.1 ↓ 4: 1.7 ↗ 5: 8.2 →</p>
Serie 45		Serie 37	
Total 92		Total 129	

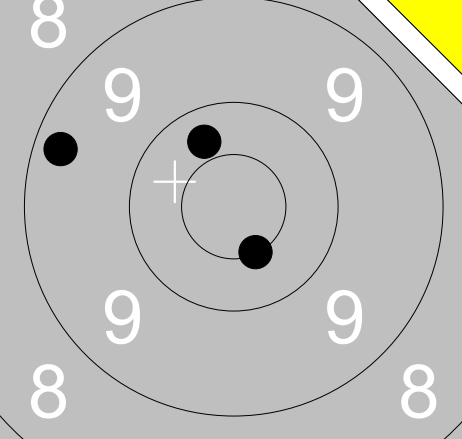
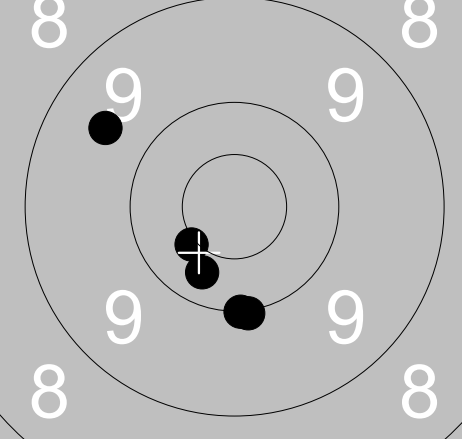
<p><b>Prov</b></p> 	<p>1: 9.3 ← 2: 10.5x ↘ 3: 10.3 ↗</p>	<p><b>4. Serie 5 Skott</b></p> 	<p>1: 10.0 ↓ 2: 10.4x ↙ 3: 10.3 ↘ 4: 9.6 ↖ 5: 10.0 ↓</p>
Serie 29		Serie 49	
Total 129		Total 178	

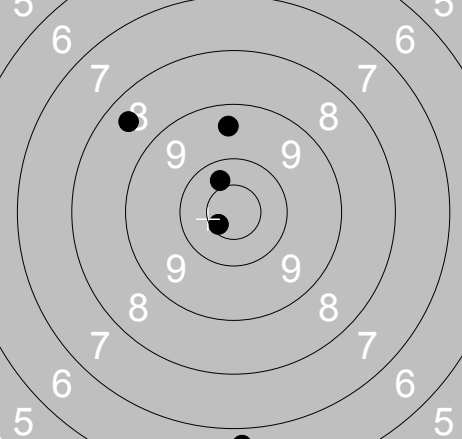
<p><b>5. Serie 5 Skott</b></p> 	<p>1: 9.4 ↑ 2: 8.5 ↗ 3: 10.4 ↗ 4: 10.6x ↙ 5: 6.7 ↓</p>		
Serie 43			
Total 221			

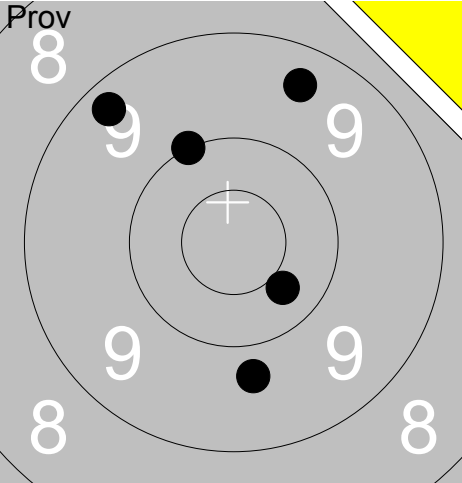
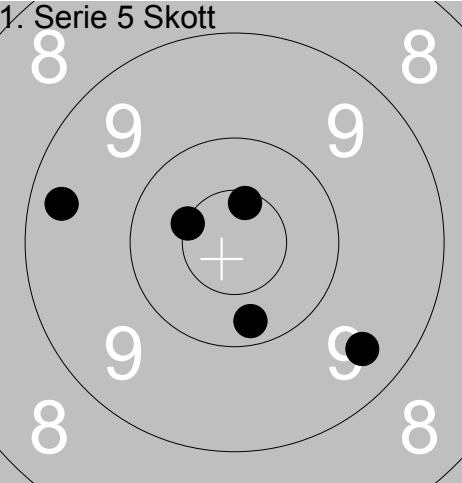
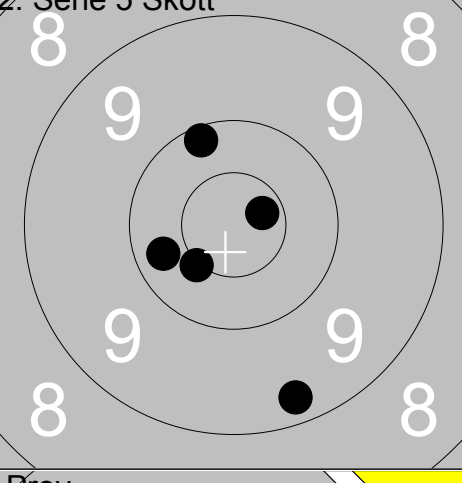
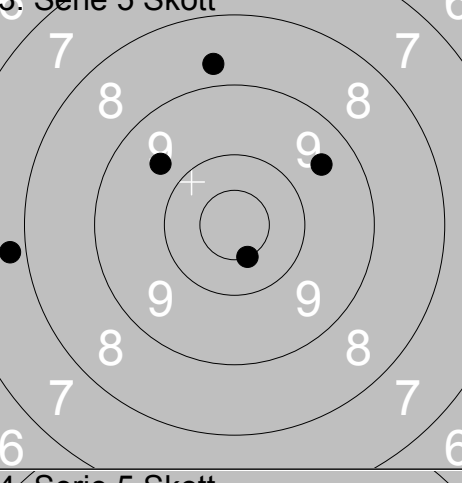
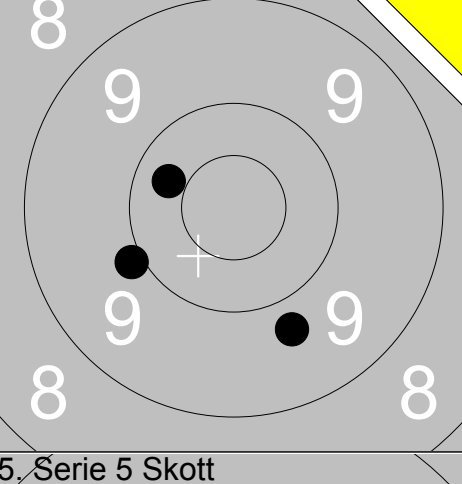
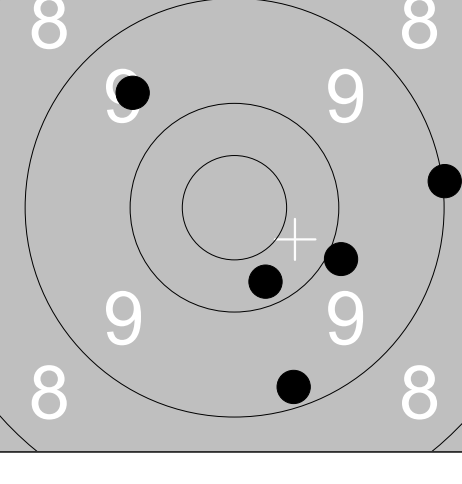
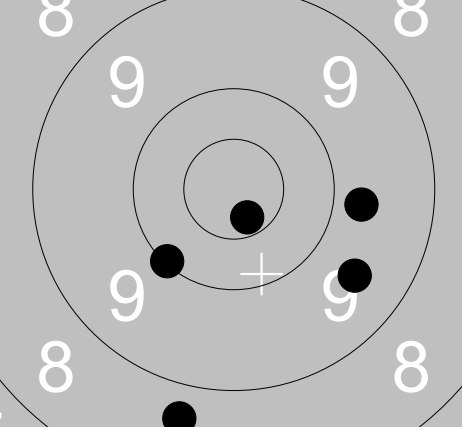

Skjutlag <b>3</b>	Tavla <b>8</b>	<b>David Augustsson</b>	
Ramselefors	Eda	Öpp	Vä
13.08.2017	SM Banskytte Ställning 2017	Ramselefors SKF	
Prov 	1: 10.4 ↘ 2: 9.4 ↗ 3: 10.0 ↗ 4: 9.3 ↗ 5: 9.7 ↓	1. Serie 5 Skott 	1: 10.5x ← 2: 9.4 ↘ 3: 10.6x ↗ 4: 10.2 ↓ 5: 9.3 ←
	Serie 47 Total 0		Serie 48 Total 48
2. Serie 5 Skott 	1: 10.7x → 2: 9.3 ↓ 3: 10.5x ↘ 4: 10.3 ← 5: 10.1 ↗	3. Serie 5 Skott 	1: 9.5 ↗ 2: 10.5x ↓ 3: 9.7 ↗ 4: 7.8 ← 5: 8.7 ↗
	Serie 49 Total 97		Serie 43 Total 140
Prov 	1: 10.3 ← 2: 9.7 ↓ 3: 9.9 ←	4. Serie 5 Skott 	1: 9.0 → 2: 9.9 ↘ 3: 9.2 ↓ 4: 10.2 ↓ 5: 9.6 ↗
	Serie 28 Total 140		Serie 46 Total 186
5. Serie 5 Skott 	1: 9.8 → 2: 10.0 ↘ 3: 10.7x ↘ 4: 8.7 ↓ 5: 9.6 ↘		
	Serie 46 Total 232		

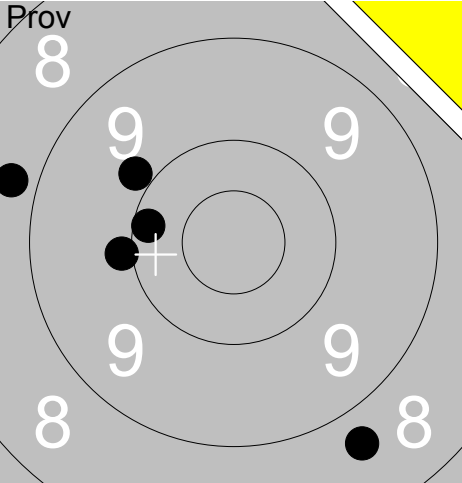
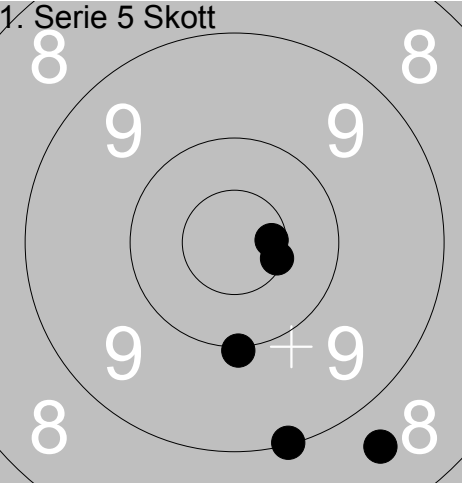
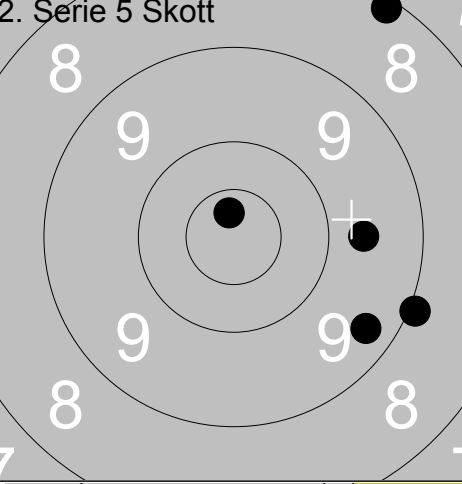
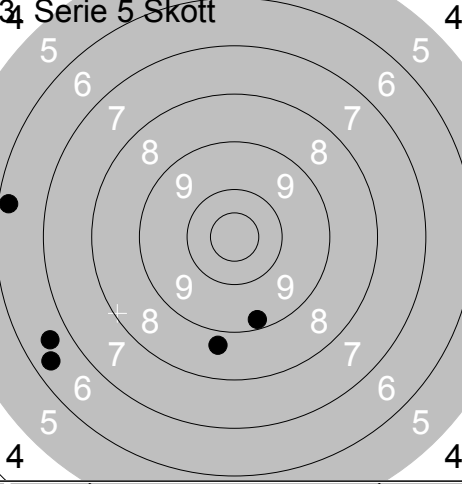
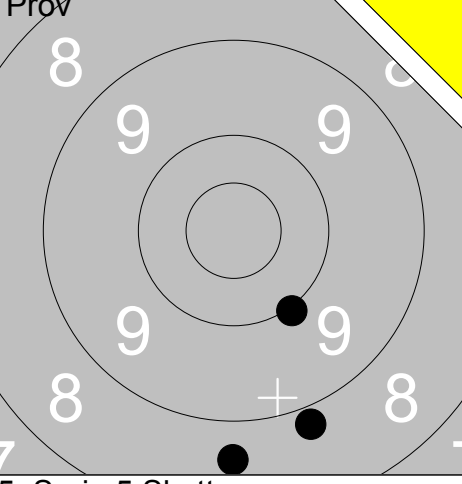
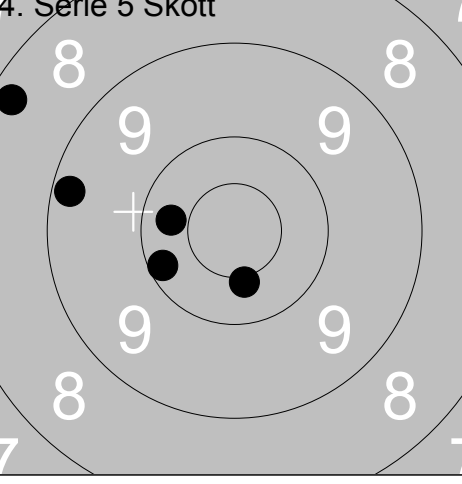
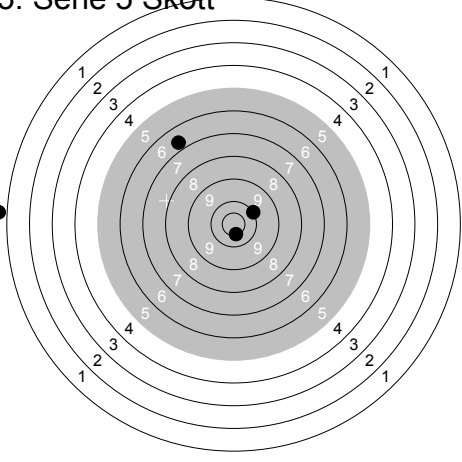
Skjutlag <b>3</b>	Tavla <b>9</b>	<b>Emma Eriksson</b>	
Ramselefors	Ramselefors	Öpp	Vb
13.08.2017	SM Banskytte Ställning 2017	Ramselefors SKF	
<b>Prov</b> 	1: 10.2 ← 2: 8.8 ← 3: 9.9 ↗ 4: 9.9 ← 5: 8.7 ↘  Serie 44 Total 0	<b>1. Serie 5 Skott</b> 	1: 10.6x → 2: 10.0 ↓ 3: 9.0 ↓ 4: 8.6 ↓ 5: 10.6x →  Serie 47 Total 47
<b>2. Serie 5 Skott</b> 	1: 9.0 → 2: 9.7 → 3: 9.3 ↘ 4: 10.7x ↑ 5: 8.1 ↗  Serie 45 Total 92	<b>3. Serie 5 Skott</b> 	1: 6.2 ← 2: 8.7 ↓ 3: 6.6 ← 4: 9.2 ↓ 5: 6.4 ↙  Serie 35 Total 127
<b>Prov</b> 	1: 8.8 ↓ 2: 8.6 ↓ 3: 10.0 ↓  Serie 26 Total 127	<b>4. Serie 5 Skott</b> 	1: 10.2 ← 2: 8.3 ↖ 3: 10.3 ← 4: 10.4x ↓ 5: 9.2 ←  Serie 47 Total 174
<b>5. Serie 5 Skott</b> 	1: 10.0 ↗ 2: 6.7 ↗ 3: 10.6x ↓ 4: 0.0 ← 5: 0.0  Serie 26 Total 200		

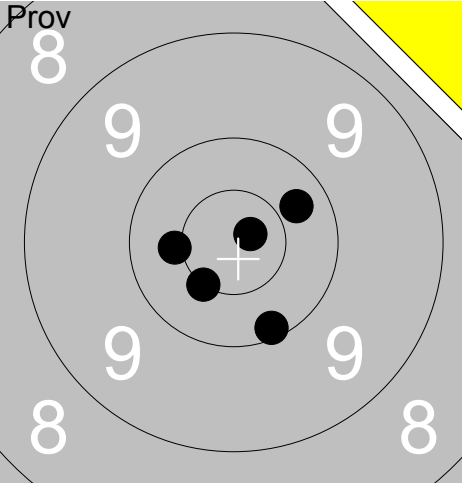
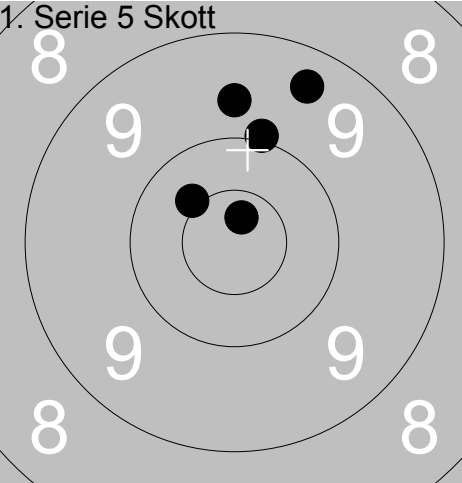
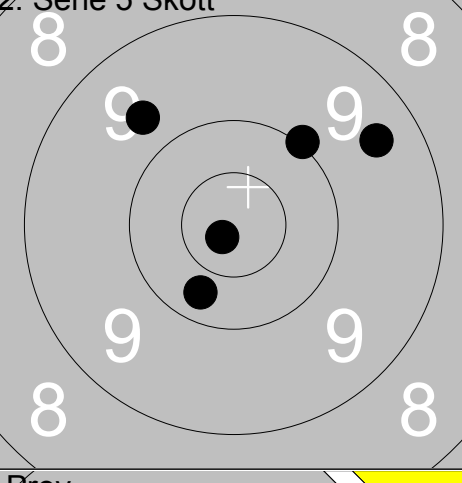
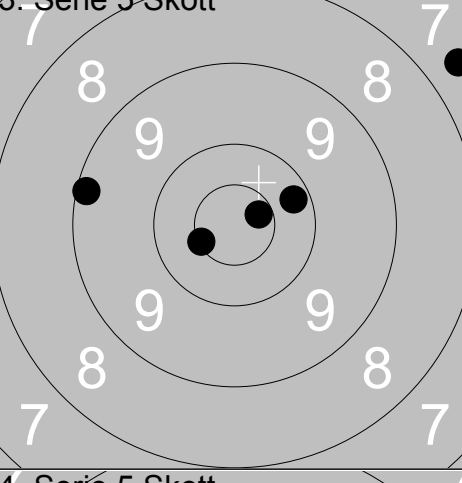
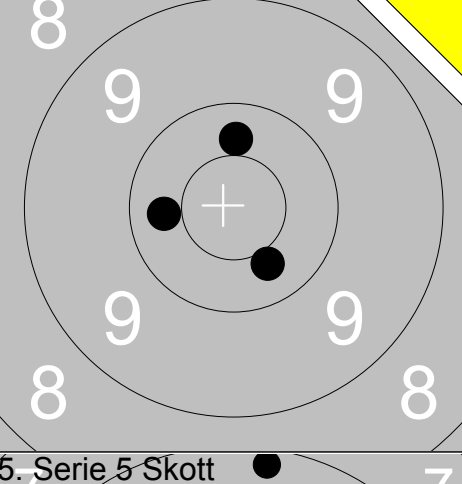
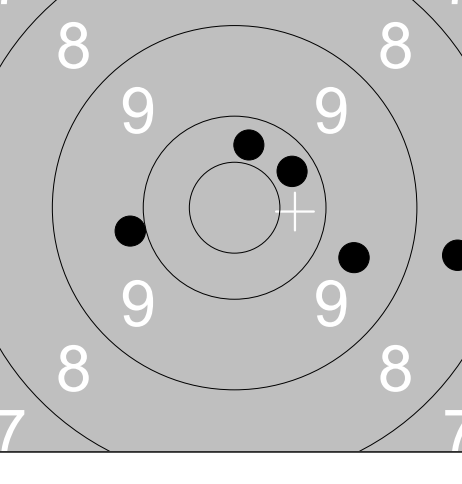
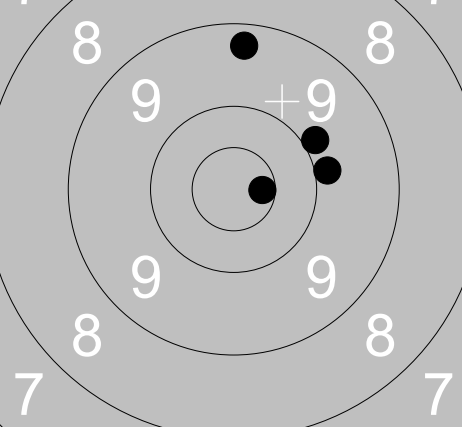
Skjutlag	Tavla	Henry Håkansson	
3	10	Ramselefors	Eda
13.08.2017	SM Banskytte Ställning 2017	Ramselefors SKF	Öpp Vä
Prov		1. Serie 5 Skott	
	1: 10.4x ← 2: 10.3 → 3: 10.5x ↓ 4: 10.8x → 5: 10.1 ↓		1: 10.7x ↑ 2: 9.4 ↑ 3: 10.4x ↖ 4: 10.0 ↑ 5: 9.7 ↑
	Serie 50 Total 0		Serie 48 Total 48
2. Serie 5 Skott		3. Serie 5 Skott	
	1: 10.8x ↓ 2: 9.4 → 3: 10.3 ↓ 4: 10.0 → 5: 9.7 ↖		1: 9.2 ← 2: 10.2 → 3: 10.5x ← 4: 7.6 → 5: 10.6x →
	Serie 48 Total 96		Serie 46 Total 142
Prov		4. Serie 5 Skott	
	1: 10.3 ← 2: 10.4 ↓ 3: 10.3 ↑		1: 10.3 ↑ 2: 9.9 ← 3: 10.3 ↗ 4: 8.5 → 5: 9.6 ↘
	Serie 30 Total 142		Serie 46 Total 188
5. Serie 5 Skott			
	1: 8.2 ↑ 2: 9.9 → 3: 9.9 ↗ 4: 9.3 ↑ 5: 10.6x →		
	Serie 45 Total 233		

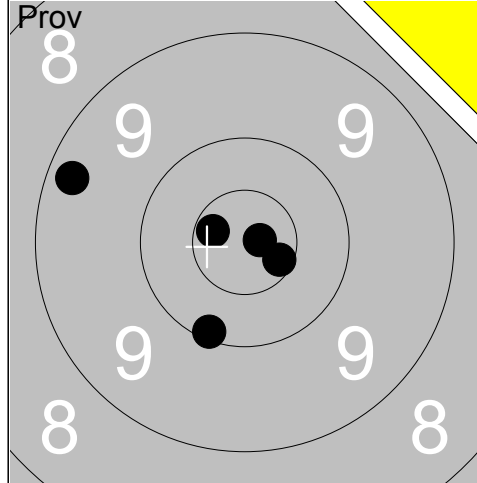

1:	10.6x	↘
2:	10.8x	→
3:	9.3	↗
4:	10.7x	↗
5:	10.1	↘
Serie		49
Total		0

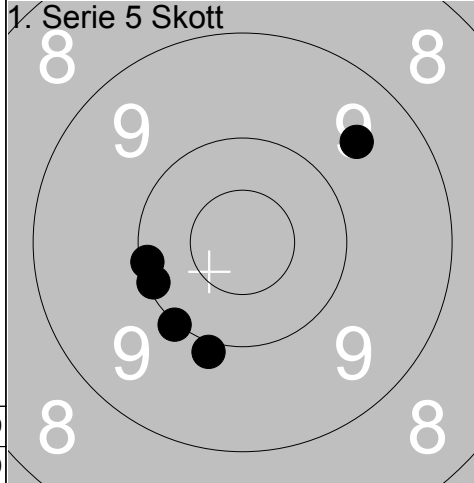

1:	9.6	↗
2:	10.0	↘
3:	10.1	←
4:	10.1	↙
5:	9.9	↘
Serie		48
Total		48

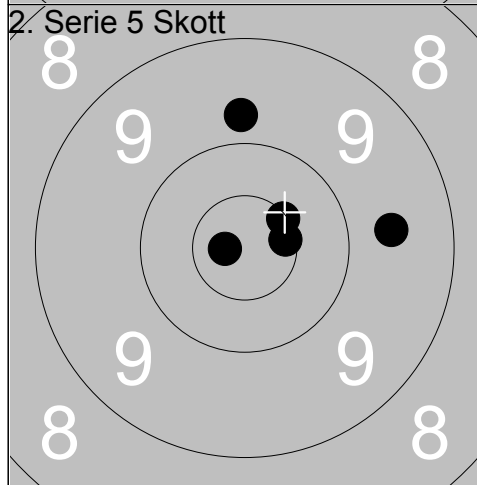

1:	9.6	→
2:	9.8	↑
3:	10.5x	↗
4:	10.6x	→
5:	10.8x	←
Serie		48
Total		96

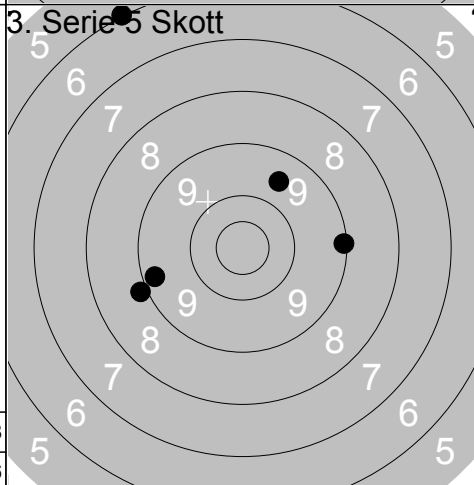

1:	9.1	→
2:	8.9	↙
3:	9.6	↗
4:	9.3	←
5:	6.0	↗
Serie		41
Total		137

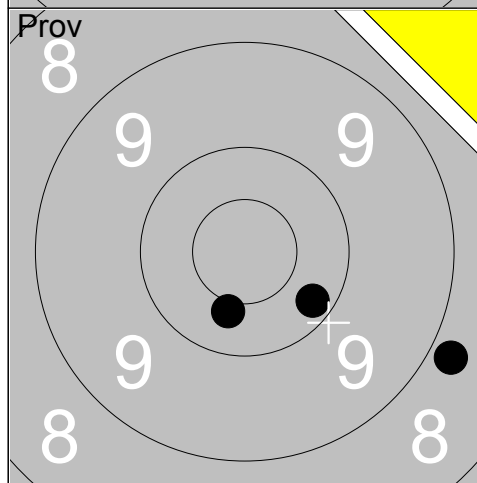

1:	10.4	↘
2:	10.2	↘
3:	8.8	↘
Serie		28
Total		137

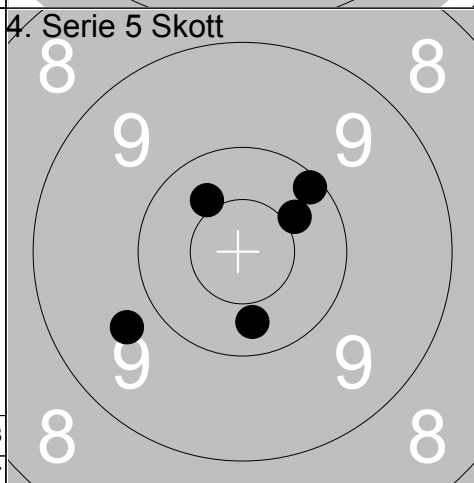

1:	10.4	↗
2:	10.4	↗
3:	10.3	↘
4:	9.7	↙
5:	10.1	↗
Serie		49
Total		186

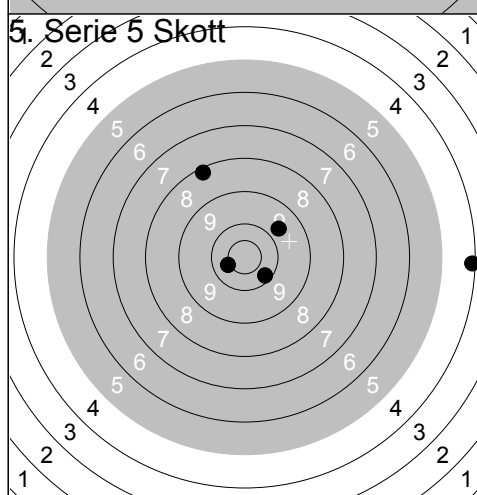

1:	9.7	↗
2:	10.4x	←
3:	10.2	↘
4:	4.1	→
5:	8.2	↗
Serie		41
Total		227

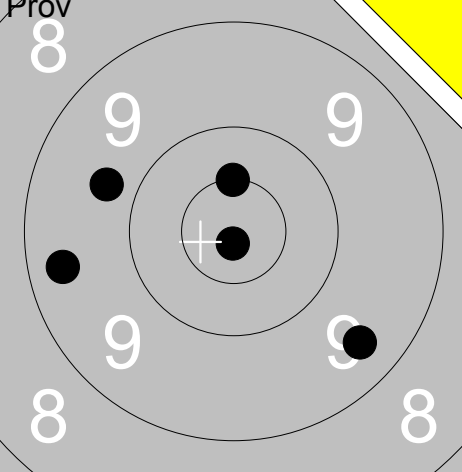
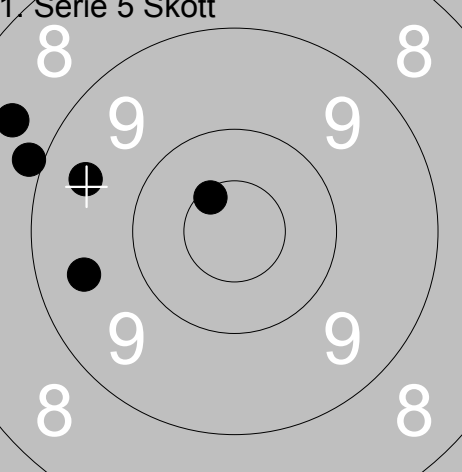
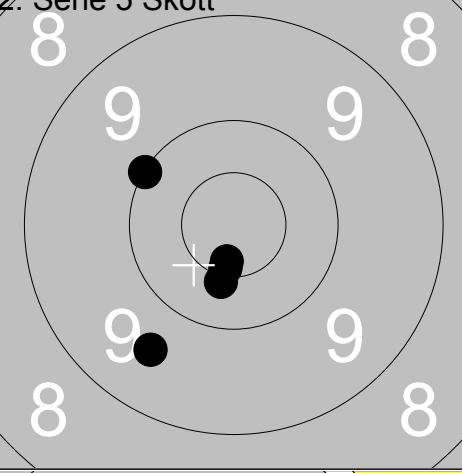
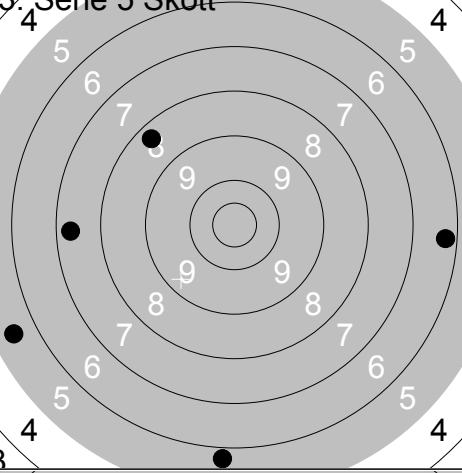
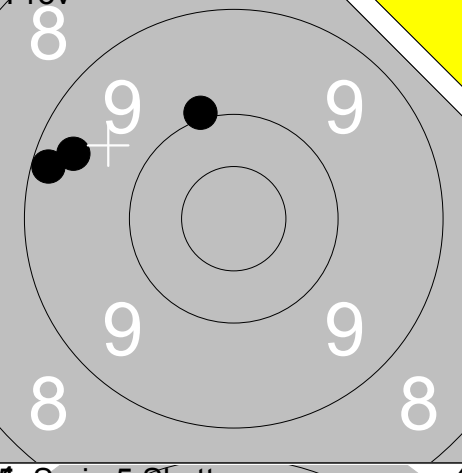
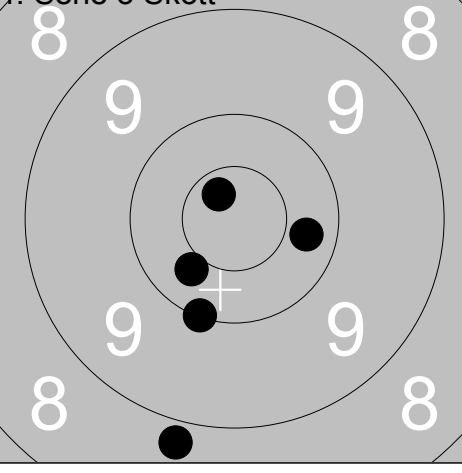
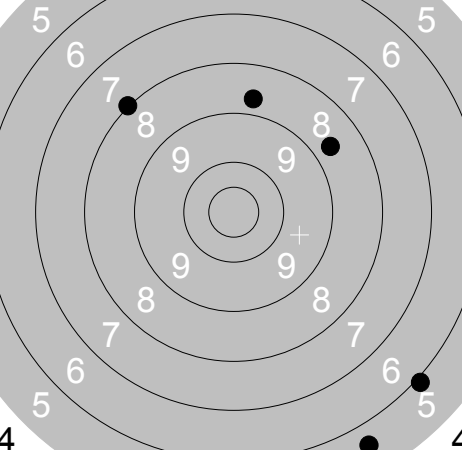
<p><b>Prov</b></p> 	<p>1: 10.5x ↑</p> <p>2: 9.4 ←</p> <p>3: 10.8x ↓</p> <p>4: 9.4 ↓</p> <p>5: 9.7 ↑</p>	<p><b>1. Serie 5 Skott</b></p> 	<p>1: 8.9 ↖</p> <p>2: 9.5 ↖</p> <p>3: 8.6 ↗</p> <p>4: 10.6x ↗</p> <p>5: 9.5 ←</p>
Serie 47	Total 0	Serie 44	Total 44
<p><b>2. Serie 5 Skott</b></p> 	<p>1: 10.6x ↓</p> <p>2: 10.6x ↓</p> <p>3: 10.4x ↓</p> <p>4: 10.0 ↗</p> <p>5: 9.6 ↓</p>	<p><b>3. Serie 5 Skott</b></p> 	<p>1: 8.3 ↗</p> <p>2: 7.3 ←</p> <p>3: 6.3 →</p> <p>4: 5.8 ↓</p> <p>5: 5.5 ↖</p>
Serie 49	Total 93	Serie 31	Total 124
<p><b>Prov</b></p> 	<p>1: 9.4 ←</p> <p>2: 9.2 ←</p> <p>3: 10.0 ↗</p>	<p><b>4. Serie 5 Skott</b></p> 	<p>1: 10.3 →</p> <p>2: 10.4 ↖</p> <p>3: 10.0 ↓</p> <p>4: 10.7x ↗</p> <p>5: 8.8 ↓</p>
Serie 28	Total 124	Serie 48	Total 172
<p><b>5. Serie 5 Skott</b></p> 	<p>1: 8.7 ↗</p> <p>2: 8.0 ↗</p> <p>3: 8.7 ↑</p> <p>4: 5.9 ↓</p> <p>5: 5.6 ↓</p>		
Serie 34	Total 206		

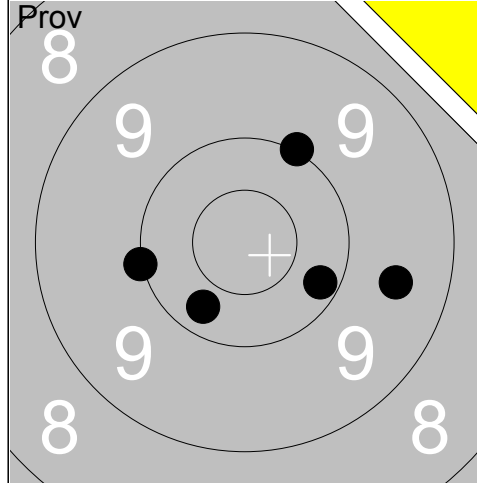

1:	10.3	↙
2:	10.0	←
3:	10.2	↘
4:	10.0	↗
5:	9.5	→
Serie		49
Total		0

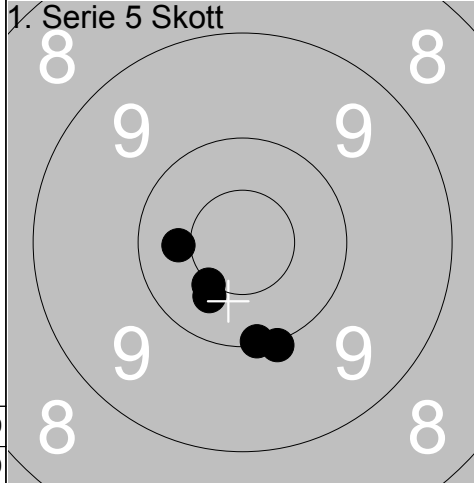

1:	10.0	↓
2:	10.4	←
3:	10.4	↙
4:	10.5x	↘
5:	10.1	↓
Serie		50
Total		50

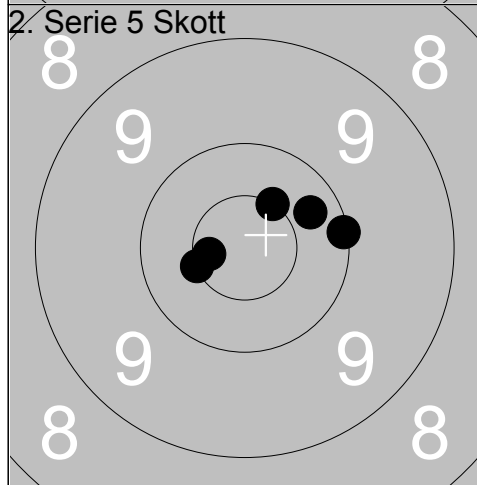

1:	10.5x	←
2:	10.1	→
3:	10.5x	↗
4:	10.6x	←
5:	10.3	→
Serie		50
Total		100

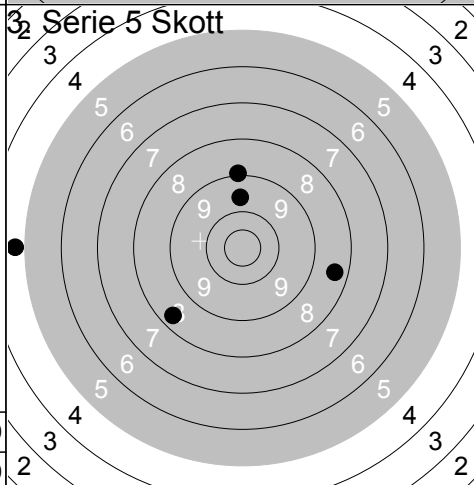

1:	9.6	↑
2:	9.0	↑
3:	8.4	↙
4:	8.4	→
5:	4.8	←
Serie		38
Total		138

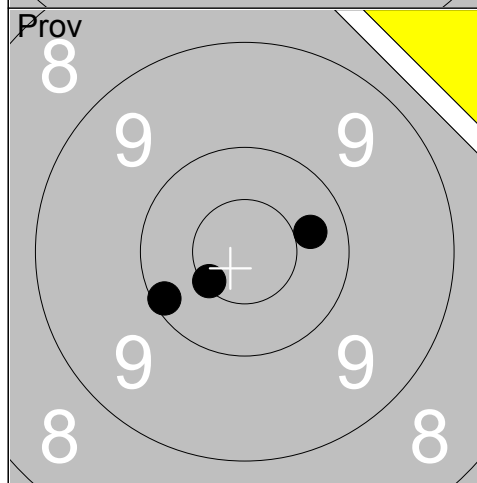

1:	10.5x	↙
2:	10.1	←
3:	10.3	→
Serie		30
Total		138

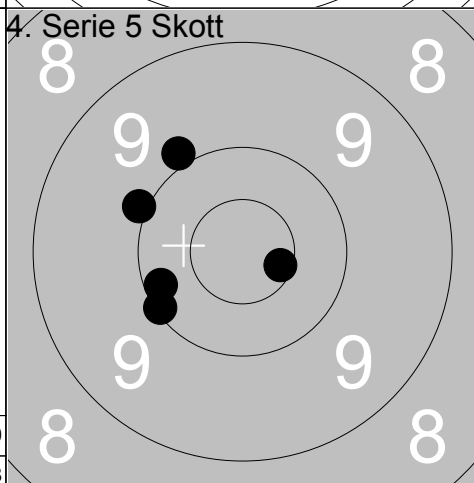

1:	10.6x	→
2:	10.2	←
3:	10.0	↖
4:	9.9	↗
5:	10.1	↙
Serie		49
Total		187

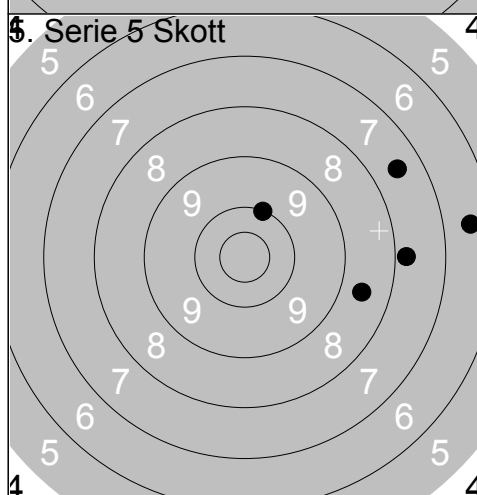

1:	10.0	↗
2:	7.8	→
3:	8.6	→
4:	6.5	→
5:	7.5	↘
Serie		38
Total		225

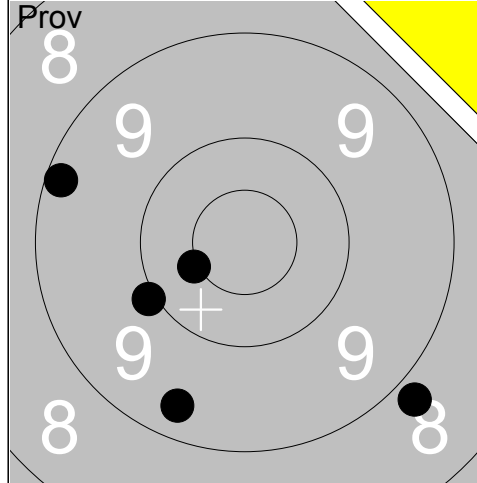

1:	10.0	↖
2:	10.5x	↖
3:	9.3	↘
4:	8.8	↘
5:	9.2	↗
Serie		46
Total		0

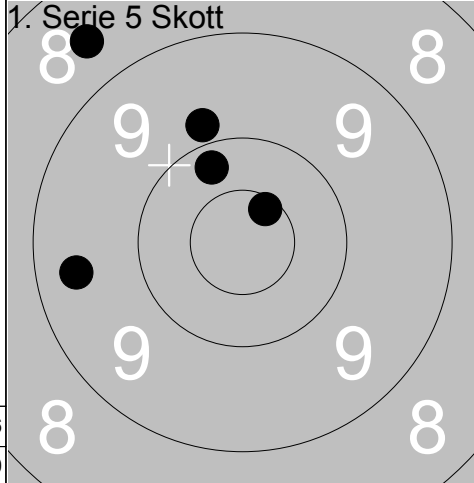

1:	8.6	↗
2:	9.4	↖
3:	10.2	↗
4:	9.8	↗
5:	10.6x	↗
Serie		46
Total		46

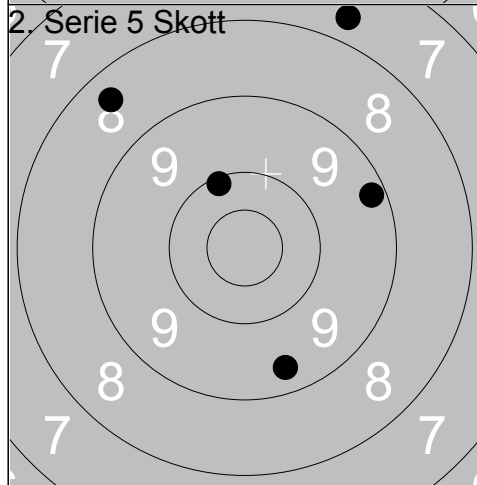

1:	7.7	↗
2:	9.2	➔
3:	9.4	↘
4:	8.4	↗
5:	10.1	↗
Serie		43
Total		89

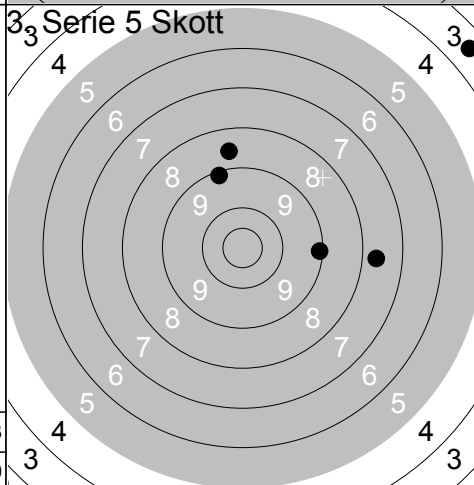

1:	8.6	↗
2:	9.1	➔
3:	9.1	↗
4:	3.5	↗
5:	7.7	➔
Serie		36
Total		125

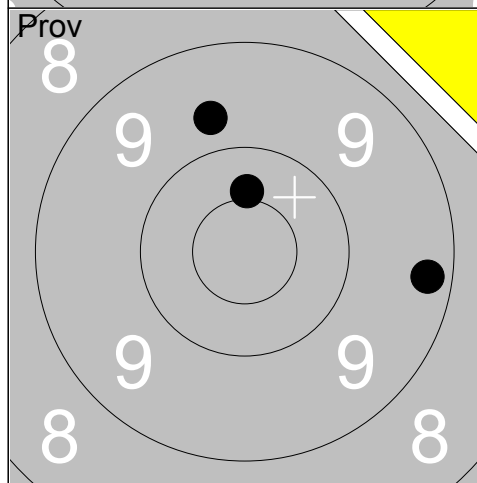

1:	9.3	➔
2:	10.4x	↗
3:	9.7	↗
Serie		28
Total		125

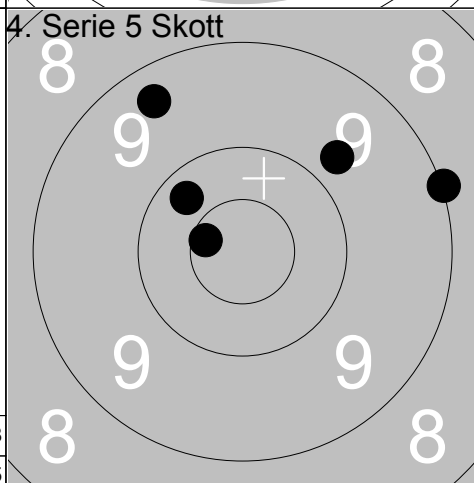

1:	9.0	➔
2:	10.6x	↖
3:	9.4	↗
4:	10.3	↗
5:	9.8	↗
Serie		47
Total		172

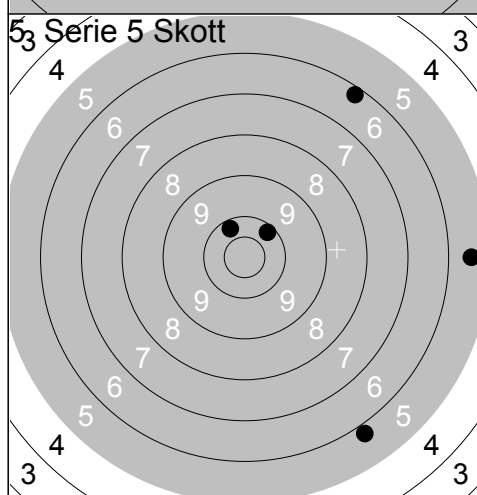

1:	10.2	↗
2:	10.2	↗
3:	5.5	➔
4:	5.8	↘
5:	6.2	↗
Serie		36
Total		208

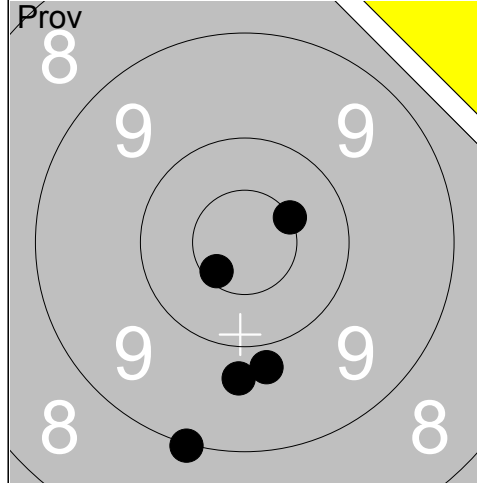

1:	10.5x	↗
2:	9.0	↓
3:	9.8	↓
4:	9.7	↓
5:	10.6x	↙
Serie		47
Total		0

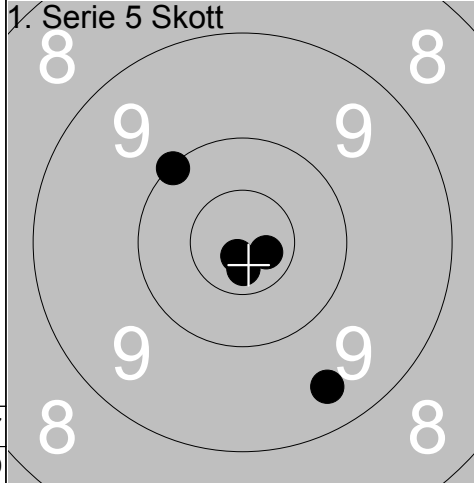

1:	10.7x	↗
2:	10.0	↗
3:	10.7x	↓
4:	10.8x	↓
5:	9.4	↓
Serie		49
Total		49

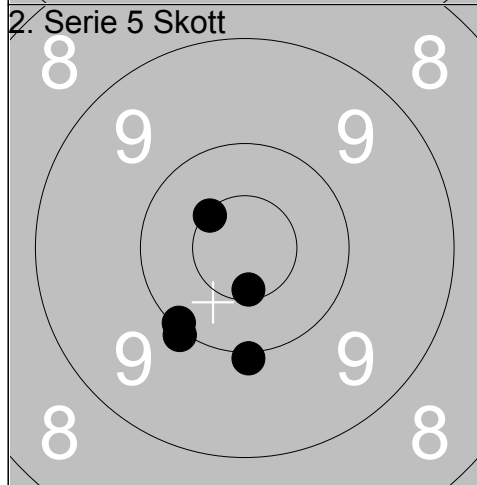

1:	10.5x	↖
2:	10.6x	↓
3:	10.0	↙
4:	10.0	↓
5:	10.1	↙
Serie		50
Total		99

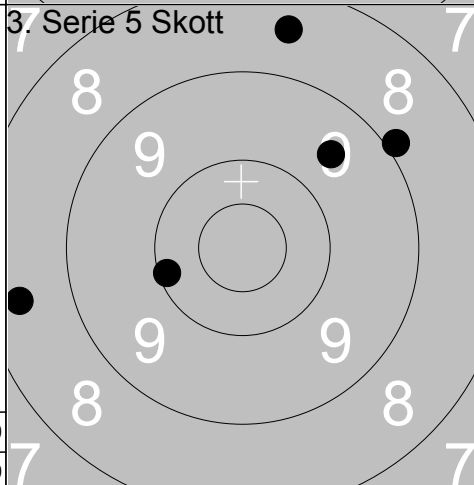

1:	8.9	↗
2:	9.6	↗
3:	10.1	←
4:	8.4	←
5:	8.5	↑
Serie		43
Total		142

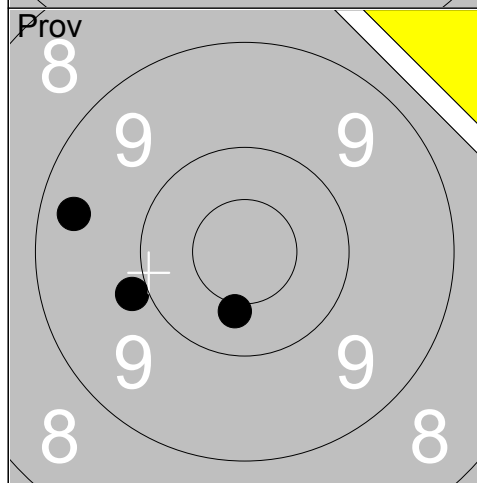

1:	9.9	←
2:	9.4	←
3:	10.4x	↓
Serie		28
Total		142

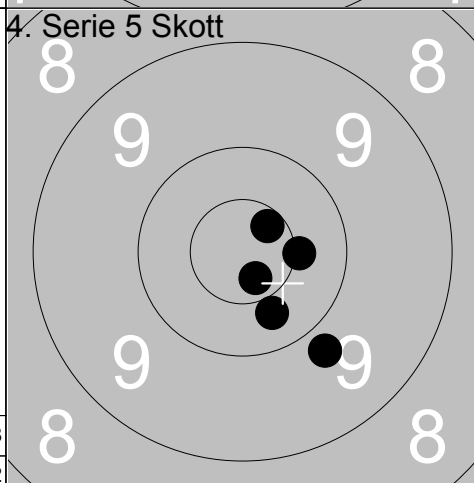

1:	10.3	↓
2:	10.4x	→
3:	10.7x	↓
4:	10.6x	↗
5:	9.8	↓
Serie		49
Total		191

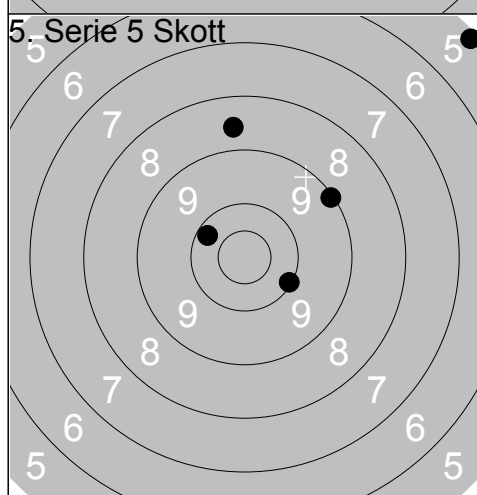

1:	10.2	↖
2:	10.1	↘
3:	9.1	↗
4:	5.2	↗
5:	8.6	↑
Serie		42
Total		233



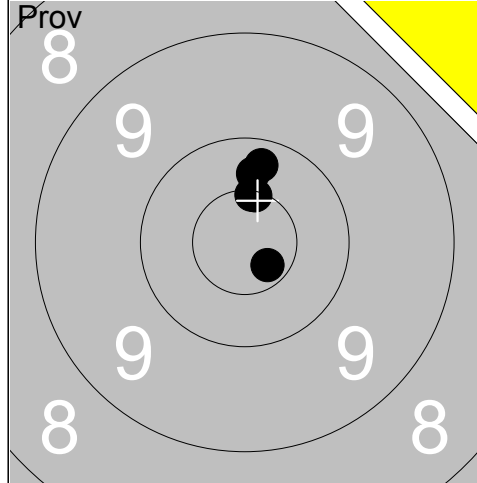

1:	10.3	↑
2:	10.5x	↑
3:	10.3	↑
4:	10.5x	↑
5:	10.7x	↘

Serie	50
Total	0

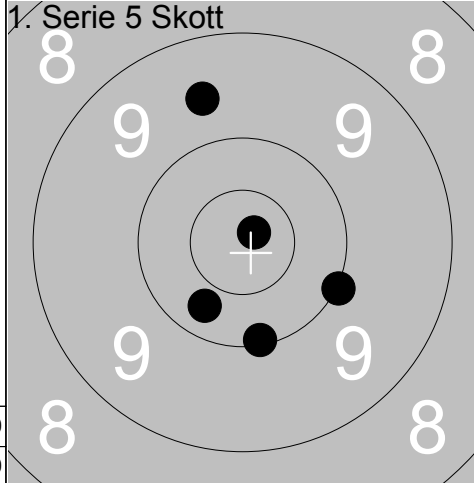

1:	10.3	↘
2:	10.8x	↗
3:	10.1	↘
4:	9.6	↑
5:	10.0	↘

Serie	49
Total	49

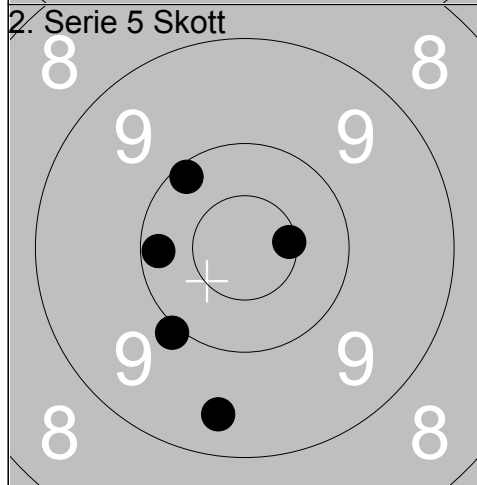

1:	10.5x	→
2:	10.1	↗
3:	10.2	←
4:	10.0	↘
5:	9.4	↘

Serie	49
Total	98

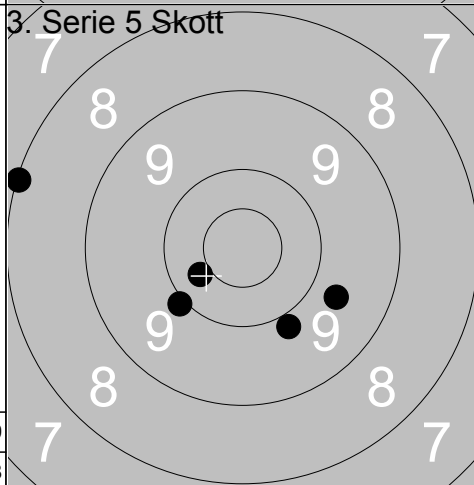

1:	10.4	↙
2:	9.9	↘
3:	10.0	↙
4:	9.7	↘
5:	8.1	↙

Serie	46
Total	144

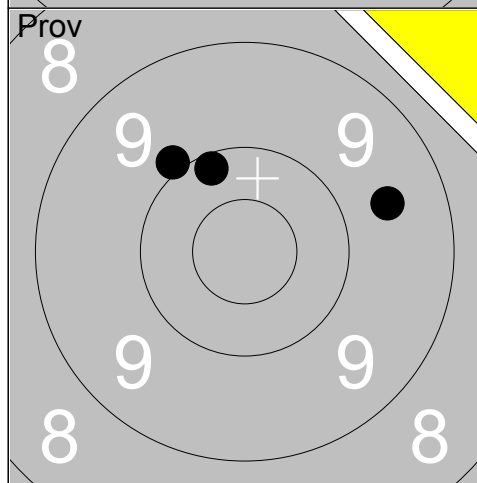

1:	9.9	↗
2:	10.2	↑
3:	9.6	→

Serie	28
Total	144

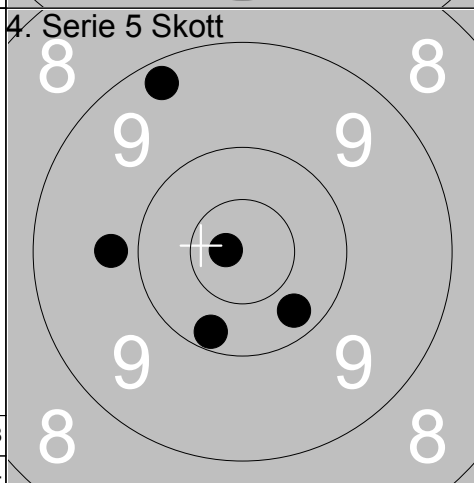

1:	10.2	↘
2:	9.8	←
3:	9.2	↗
4:	10.8x	←
5:	10.3	↘

Serie	48
Total	192

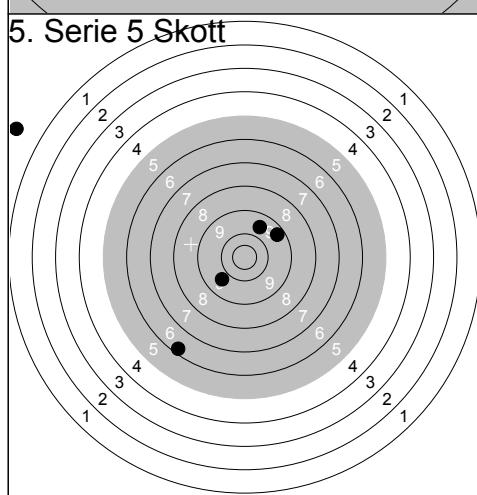

1:	9.7	↙
2:	9.6	↑
3:	9.4	↗
4:	0.0	↙
5:	6.2	↘

Serie	33
Total	225

Skjutlag	Tavla	Marlene Forsell Forsman				
3	17	Ramselefors	Ramselefors	Öpp	Vb	
13.08.2017		SM Banskytte Ställning 2017	Ramselefors SKF			
Prov		1: 9.5 ↑ 2: 10.6x ↖ 3: 10.1 ↑ 4: 10.1 ↗ 5: 10.5x ➤	1. Serie 5 Skott	 1: 10.2 ↑ 2: 10.4x ↑ 3: 9.7 ➔ 4: 9.6 ↗ 5: 10.2 ↖	Serie 49 Total 0	Serie 48 Total 48
2. Serie 5 Skott		1: 10.1 ↖ 2: 10.5x ↓ 3: 9.5 ↑ 4: 10.3 ↗ 5: 10.5x ↘	3. Serie 5 Skott	 1: 9.7 ↑ 2: 10.5x ➔ 3: 10.5x ↖ 4: 7.3 ↑ 5: 6.9 ➔	Serie 49 Total 97	Serie 42 Total 139
Prov		1: 10.4 ↑ 2: 9.6 ➔ 3: 10.0 ↓	4. Serie 5 Skott	 1: 10.9x ➔ 2: 10.0 ↖ 3: 9.7 ↘ 4: 10.0 ↘ 5: 10.5x ↗	Serie 29 Total 139	Serie 49 Total 188
5. Serie 5 Skott		1: 8.7 ➔ 2: 9.7 ↓ 3: 10.2 ➔ 4: 8.7 ↖ 5: 9.0 ↖			Serie 44 Total 232	

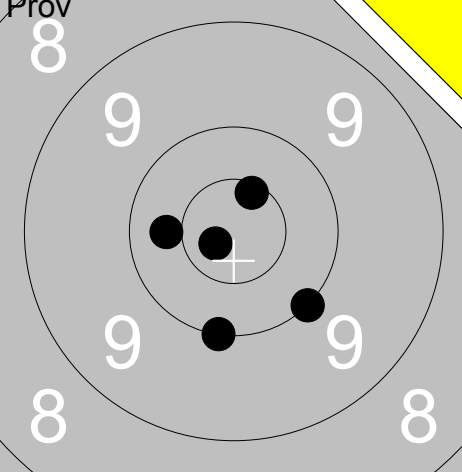
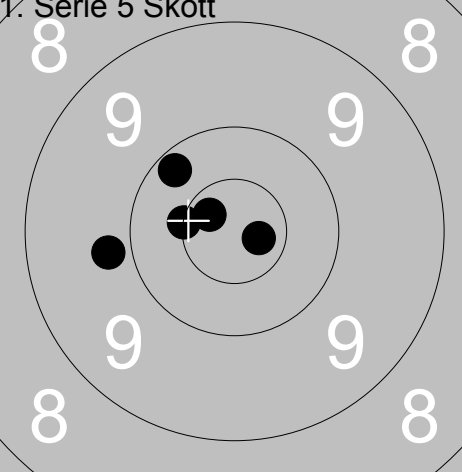
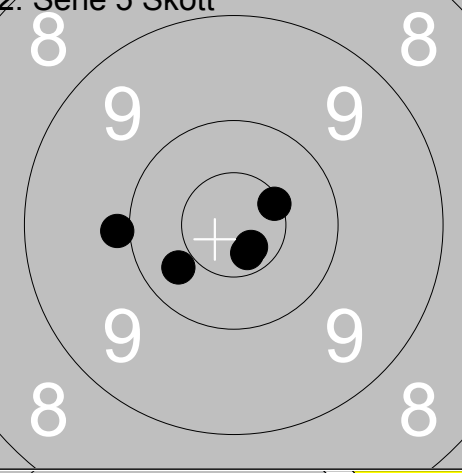
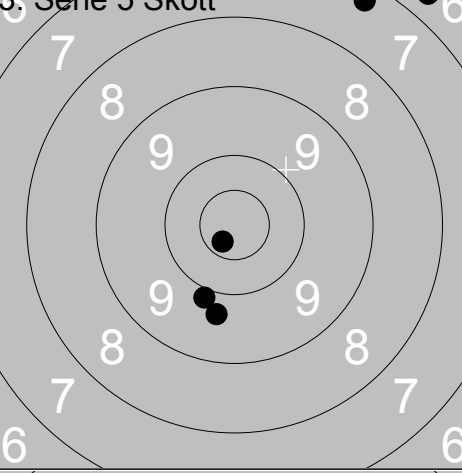
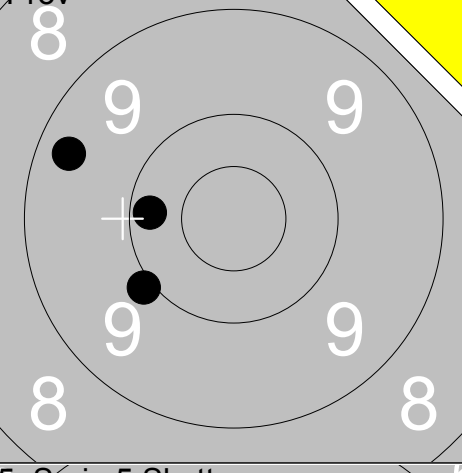
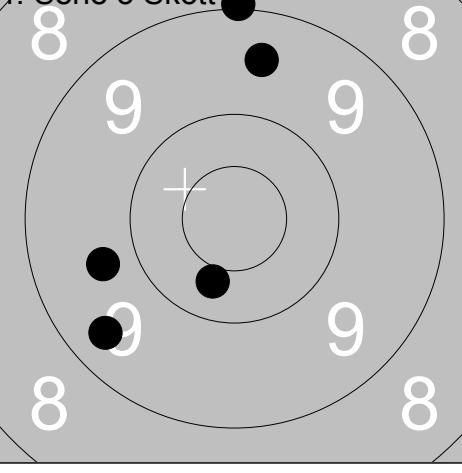
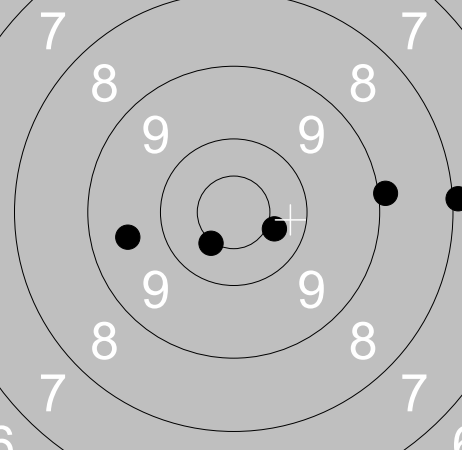
<p>Prov</p> 	<table border="1" style="width:100%; border-collapse: collapse;"> <tr><td>1:</td><td>10.0</td><td>↘</td></tr> <tr><td>2:</td><td>10.0</td><td>↓</td></tr> <tr><td>3:</td><td>10.6x</td><td>↑</td></tr> <tr><td>4:</td><td>10.4</td><td>←</td></tr> <tr><td>5:</td><td>10.8x</td><td>↙</td></tr> <tr><td colspan="2">Serie</td><td>50</td></tr> <tr><td colspan="2">Total</td><td>0</td></tr> </table>	1:	10.0	↘	2:	10.0	↓	3:	10.6x	↑	4:	10.4	←	5:	10.8x	↙	Serie		50	Total		0	<p>1. Serie 5 Skott</p>  <table border="1" style="width:100%; border-collapse: collapse;"> <tr><td>1:</td><td>10.5x</td><td>←</td></tr> <tr><td>2:</td><td>10.7x</td><td>→</td></tr> <tr><td>3:</td><td>9.8</td><td>←</td></tr> <tr><td>4:</td><td>10.7x</td><td>↗</td></tr> <tr><td>5:</td><td>10.2</td><td>↗</td></tr> <tr><td colspan="2">Serie</td><td>49</td></tr> <tr><td colspan="2">Total</td><td>49</td></tr> </table>	1:	10.5x	←	2:	10.7x	→	3:	9.8	←	4:	10.7x	↗	5:	10.2	↗	Serie		49	Total		49
1:	10.0	↘																																										
2:	10.0	↓																																										
3:	10.6x	↑																																										
4:	10.4	←																																										
5:	10.8x	↙																																										
Serie		50																																										
Total		0																																										
1:	10.5x	←																																										
2:	10.7x	→																																										
3:	9.8	←																																										
4:	10.7x	↗																																										
5:	10.2	↗																																										
Serie		49																																										
Total		49																																										
<p>2. Serie 5 Skott</p> 	<table border="1" style="width:100%; border-collapse: collapse;"> <tr><td>1:</td><td>10.5x</td><td>→</td></tr> <tr><td>2:</td><td>10.7x</td><td>↓</td></tr> <tr><td>3:</td><td>10.7x</td><td>↓</td></tr> <tr><td>4:</td><td>10.3</td><td>↙</td></tr> <tr><td>5:</td><td>9.9</td><td>←</td></tr> <tr><td colspan="2">Serie</td><td>49</td></tr> <tr><td colspan="2">Total</td><td>98</td></tr> </table>	1:	10.5x	→	2:	10.7x	↓	3:	10.7x	↓	4:	10.3	↙	5:	9.9	←	Serie		49	Total		98	<p>3. Serie 5 Skott</p>  <table border="1" style="width:100%; border-collapse: collapse;"> <tr><td>1:</td><td>10.7x</td><td>↙</td></tr> <tr><td>2:</td><td>9.7</td><td>↓</td></tr> <tr><td>3:</td><td>9.9</td><td>↓</td></tr> <tr><td>4:</td><td>6.7</td><td>↗</td></tr> <tr><td>5:</td><td>7.3</td><td>↗</td></tr> <tr><td colspan="2">Serie</td><td>41</td></tr> <tr><td colspan="2">Total</td><td>139</td></tr> </table>	1:	10.7x	↙	2:	9.7	↓	3:	9.9	↓	4:	6.7	↗	5:	7.3	↗	Serie		41	Total		139
1:	10.5x	→																																										
2:	10.7x	↓																																										
3:	10.7x	↓																																										
4:	10.3	↙																																										
5:	9.9	←																																										
Serie		49																																										
Total		98																																										
1:	10.7x	↙																																										
2:	9.7	↓																																										
3:	9.9	↓																																										
4:	6.7	↗																																										
5:	7.3	↗																																										
Serie		41																																										
Total		139																																										
<p>Prov</p> 	<table border="1" style="width:100%; border-collapse: collapse;"> <tr><td>1:</td><td>10.2</td><td>←</td></tr> <tr><td>2:</td><td>9.3</td><td>←</td></tr> <tr><td>3:</td><td>9.9</td><td>↙</td></tr> <tr><td colspan="2">Serie</td><td>28</td></tr> <tr><td colspan="2">Total</td><td>139</td></tr> </table>	1:	10.2	←	2:	9.3	←	3:	9.9	↙	Serie		28	Total		139	<p>4. Serie 5 Skott</p>  <table border="1" style="width:100%; border-collapse: collapse;"> <tr><td>1:</td><td>9.4</td><td>↙</td></tr> <tr><td>2:</td><td>9.7</td><td>←</td></tr> <tr><td>3:</td><td>9.0</td><td>↑</td></tr> <tr><td>4:</td><td>9.5</td><td>↑</td></tr> <tr><td>5:</td><td>10.4</td><td>↓</td></tr> <tr><td colspan="2">Serie</td><td>46</td></tr> <tr><td colspan="2">Total</td><td>185</td></tr> </table>	1:	9.4	↙	2:	9.7	←	3:	9.0	↑	4:	9.5	↑	5:	10.4	↓	Serie		46	Total		185						
1:	10.2	←																																										
2:	9.3	←																																										
3:	9.9	↙																																										
Serie		28																																										
Total		139																																										
1:	9.4	↙																																										
2:	9.7	←																																										
3:	9.0	↑																																										
4:	9.5	↑																																										
5:	10.4	↓																																										
Serie		46																																										
Total		185																																										
<p>5. Serie 5 Skott</p> 	<table border="1" style="width:100%; border-collapse: collapse;"> <tr><td>1:</td><td>10.4</td><td>→</td></tr> <tr><td>2:</td><td>10.5x</td><td>↙</td></tr> <tr><td>3:</td><td>9.5</td><td>←</td></tr> <tr><td>4:</td><td>8.9</td><td>→</td></tr> <tr><td>5:</td><td>8.0</td><td>→</td></tr> <tr><td colspan="2">Serie</td><td>45</td></tr> <tr><td colspan="2">Total</td><td>230</td></tr> </table>	1:	10.4	→	2:	10.5x	↙	3:	9.5	←	4:	8.9	→	5:	8.0	→	Serie		45	Total		230																						
1:	10.4	→																																										
2:	10.5x	↙																																										
3:	9.5	←																																										
4:	8.9	→																																										
5:	8.0	→																																										
Serie		45																																										
Total		230																																										

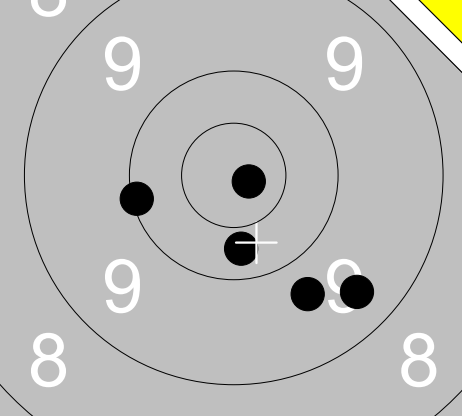
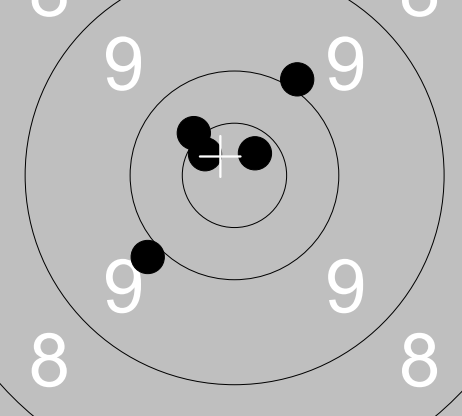
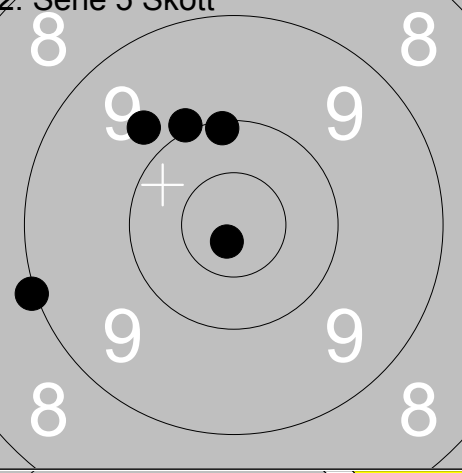
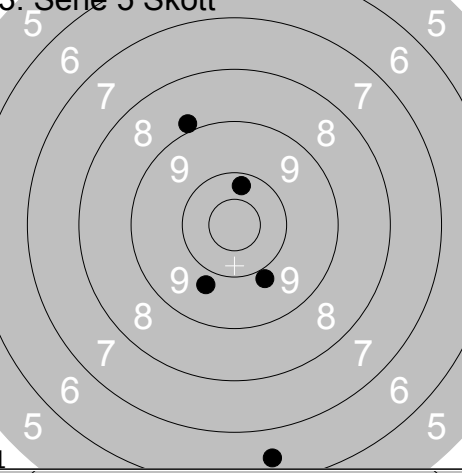
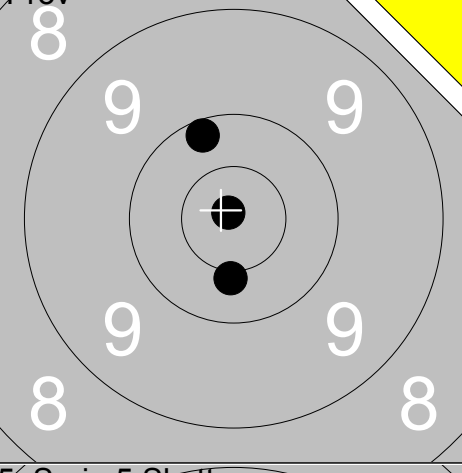
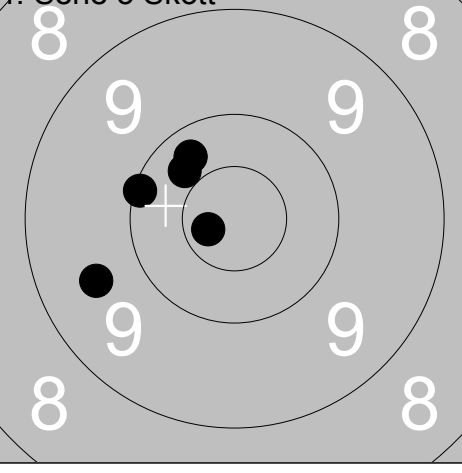
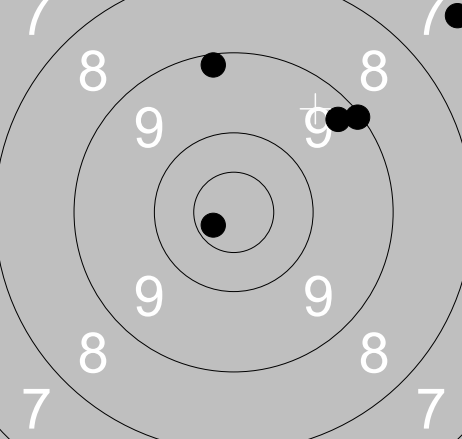
<b>Prov</b> 	1: 9.7 ↘ 2: 10.3 ↘ 3: 9.4 ↘ 4: 10.1 ← 5: 10.8x → <hr/> Serie 48 Total 0	<b>1. Serie 5 Skott</b> 	1: 9.9 ↙ 2: 10.6x ↖ 3: 9.9 ↗ 4: 10.7x ↗ 5: 10.4x ↖ <hr/> Serie 48 Total 48
<b>2. Serie 5 Skott</b> 	1: 9.8 ↗ 2: 10.0 ↗ 3: 10.1 ↗ 4: 9.0 ← 5: 10.8x ↓ <hr/> Serie 48 Total 96	<b>3. Serie 5 Skott</b> 	1: 10.2 ↑ 2: 9.8 ↓ 3: 9.7 ↓ 4: 6.5 ↓ 5: 8.9 ↗ <hr/> Serie 42 Total 138
<b>Prov</b> 	1: 10.2 ↗ 2: 10.4x ↓ 3: 10.9x ↗ <hr/> Serie 30 Total 138	<b>4. Serie 5 Skott</b> 	1: 10.1 ← 2: 9.6 ← 3: 10.7x ← 4: 10.3 ↗ 5: 10.3 ↗ <hr/> Serie 49 Total 187
<b>5. Serie 5 Skott</b> 	1: 9.2 ↑ 2: 10.7x ↖ 3: 9.1 ↗ 4: 7.3 ↗ 5: 9.3 ↗ <hr/> Serie 44 Total 231		

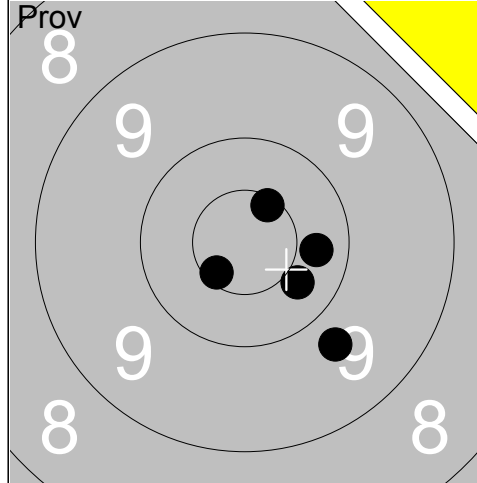

1:	10.4	↘
2:	10.3	→
3:	10.6x	↗
4:	10.6x	↙
5:	9.7	↘
Serie		49
Total		0

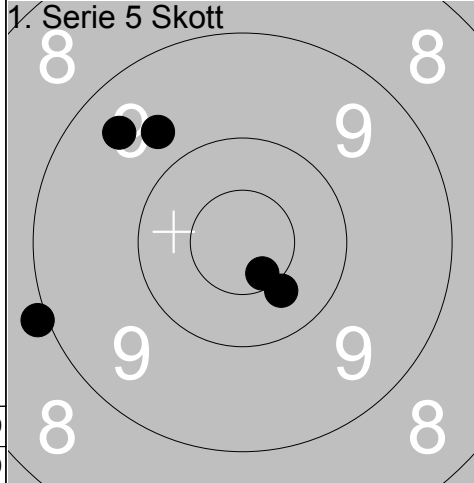

1:	10.6x	↘
2:	10.4	↘
3:	9.5	↗
4:	8.9	↙
5:	9.7	↗
Serie		46
Total		46

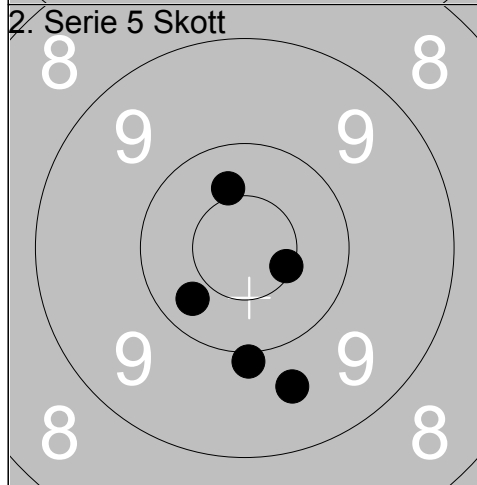

1:	10.4	↗
2:	9.6	↘
3:	10.5x	→
4:	10.3	↙
5:	9.9	↘
Serie		48
Total		94

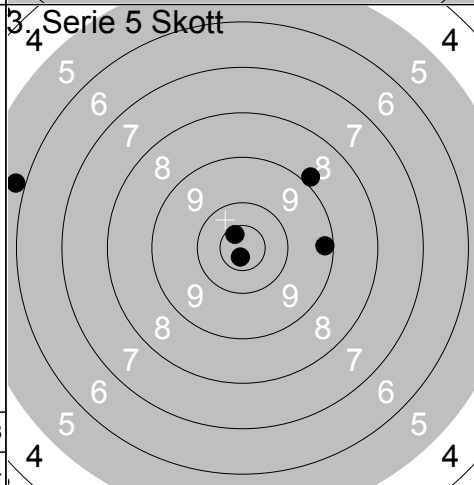

1:	10.8x	↘
2:	8.9	↗
3:	9.2	→
4:	5.8	↙
5:	10.6x	↗
Serie		42
Total		136

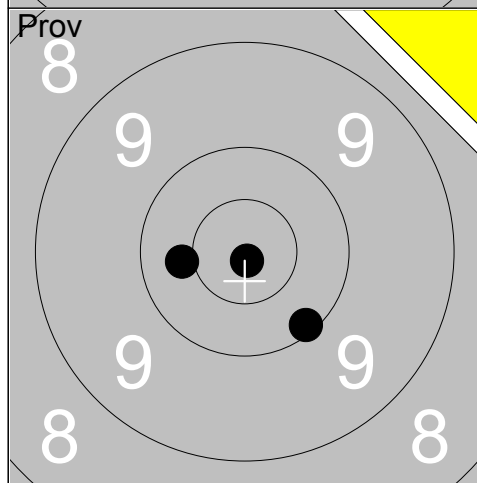

1:	10.4	↙
2:	10.9x	↘
3:	10.1	↘
Serie		30
Total		136

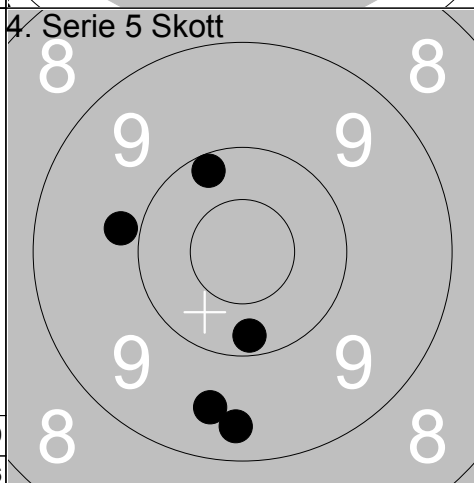

1:	9.8	↙
2:	9.4	↘
3:	10.2	↘
4:	10.2	↗
5:	9.5	↘
Serie		47
Total		183

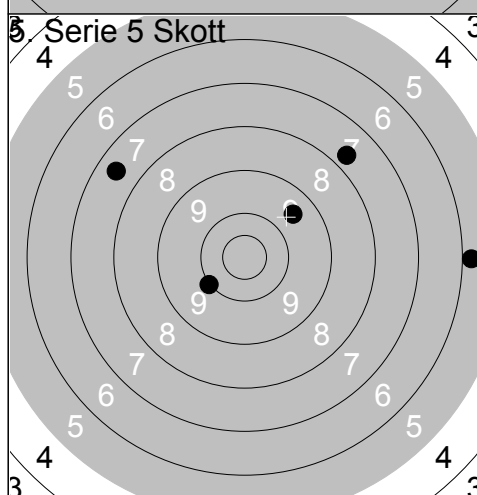

1:	10.0	↙
2:	7.7	↗
3:	9.5	↗
4:	5.8	→
5:	7.5	↗
Serie		38
Total		221

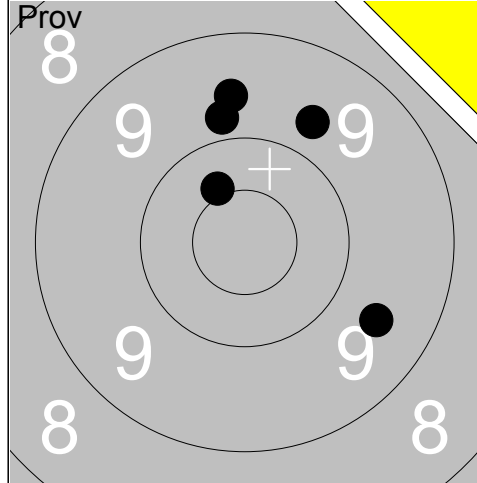

1:	10.4x	↗
2:	9.6	↑
3:	9.6	↘
4:	9.8	↑
5:	9.7	↗
Serie		46
Total		0

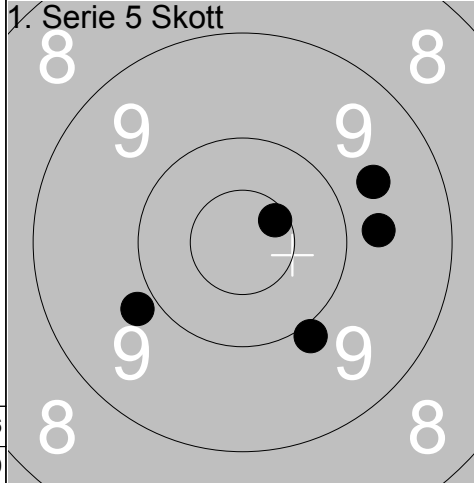

1:	9.7	↗
2:	9.7	→
3:	10.6x	↗
4:	9.8	↙
5:	9.9	↘
Serie		46
Total		46

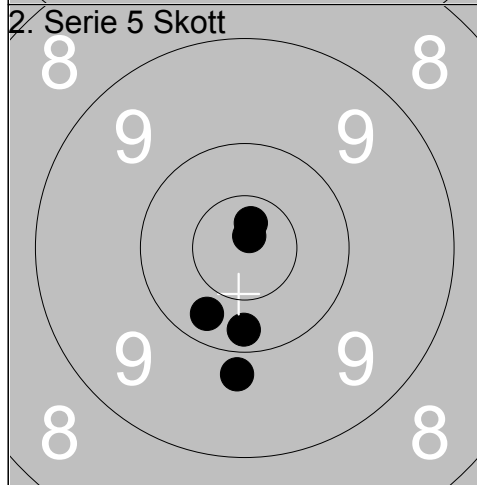

1:	10.7x	↗
2:	10.8x	↗
3:	9.8	↘
4:	10.2	↘
5:	10.3	↘
Serie		49
Total		95

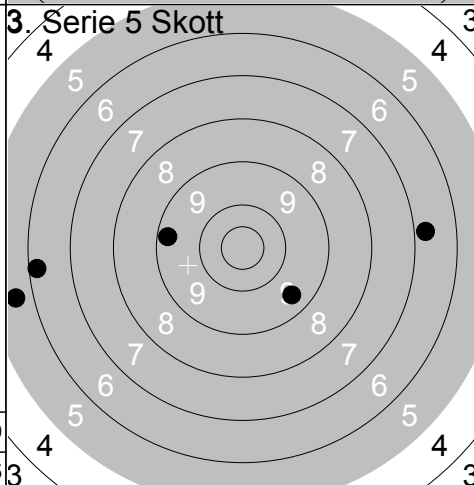

1:	6.2	←
2:	9.5	↘
3:	6.8	→
4:	9.3	←
5:	5.6	←
Serie		35
Total		130

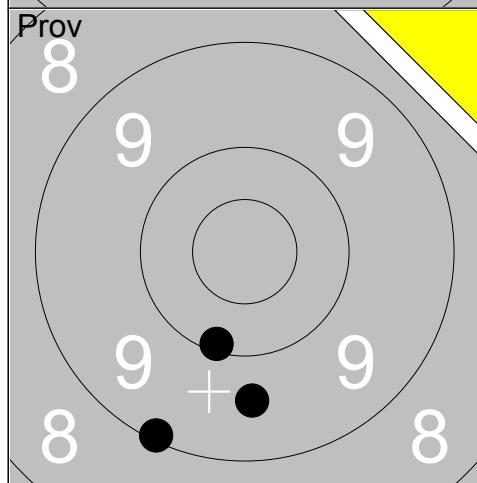

1:	10.1	↘
2:	9.6	↘
3:	9.1	↘
Serie		28
Total		130

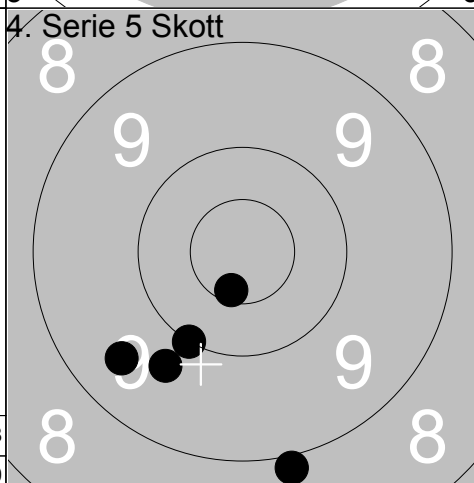

1:	10.6x	↘
2:	9.5	↙
3:	9.7	↙
4:	10.0	↘
5:	8.9	↘
Serie		46
Total		176

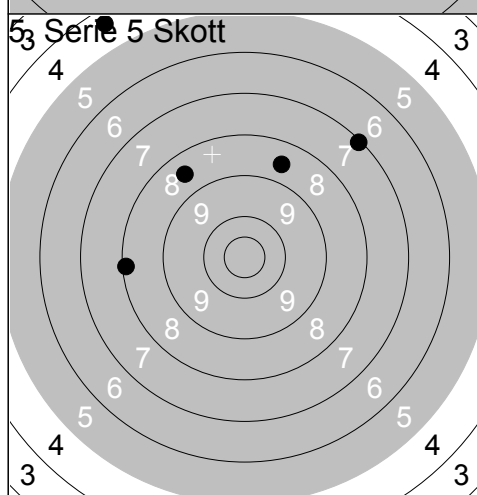

1:	7.1	↗
2:	8.6	↗
3:	8.5	↗
4:	8.1	←
5:	4.4	↗
Serie		35
Total		211

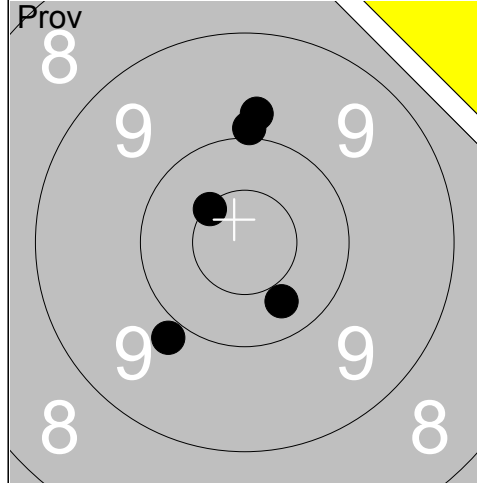

1:	10.3	↘
2:	9.8	↑
3:	9.9	↑
4:	10.5x	↖
5:	9.9	↙
Serie		47
Total		0

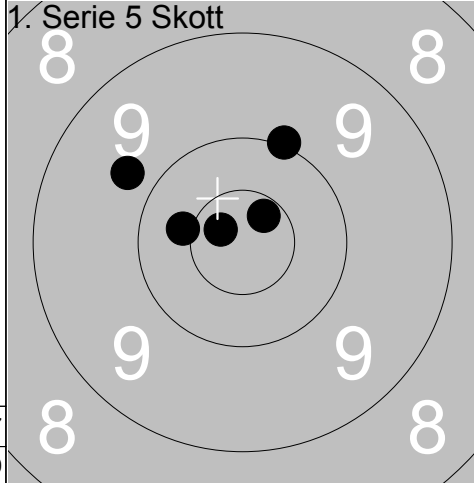

1:	10.4	↖
2:	10.6x	↗
3:	10.7x	↖
4:	9.7	↖
5:	10.0	↗
Serie		49
Total		49

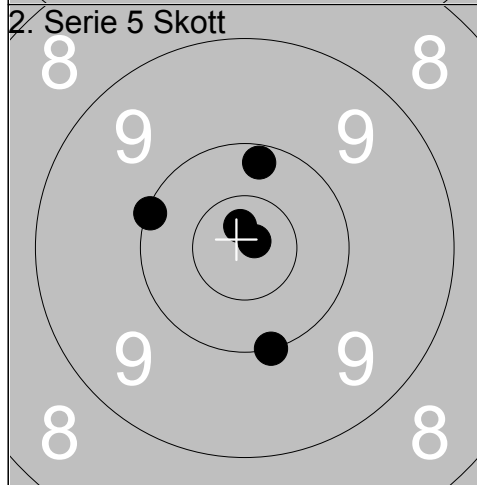

1:	10.1	↖
2:	10.8x	↑
3:	10.8x	↗
4:	10.2	↑
5:	10.0	↘
Serie		50
Total		99

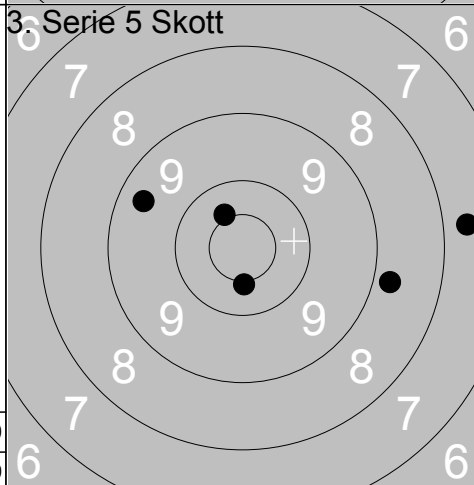

1:	10.5x	↘
2:	10.4x	↗
3:	7.7	→
4:	8.8	→
5:	9.4	↖
Serie		44
Total		143

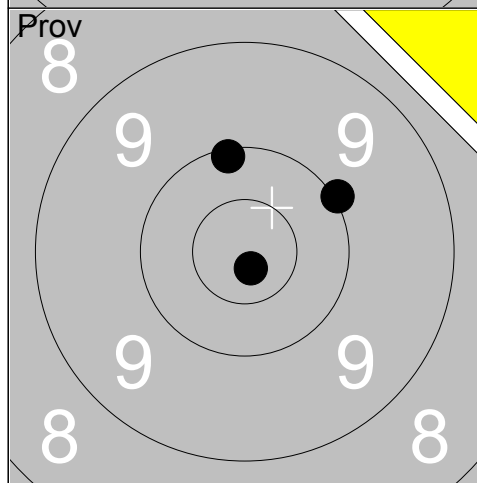

1:	10.1	↑
2:	10.0	↗
3:	10.8x	↘
Serie		30
Total		143

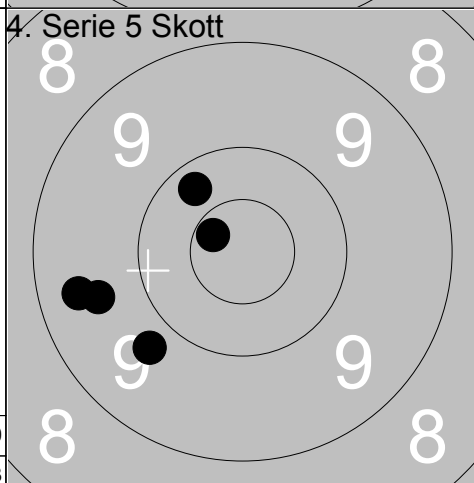

1:	10.6x	↖
2:	9.4	↖
3:	10.3	↗
4:	9.6	↖
5:	9.8	↘
Serie		47
Total		190

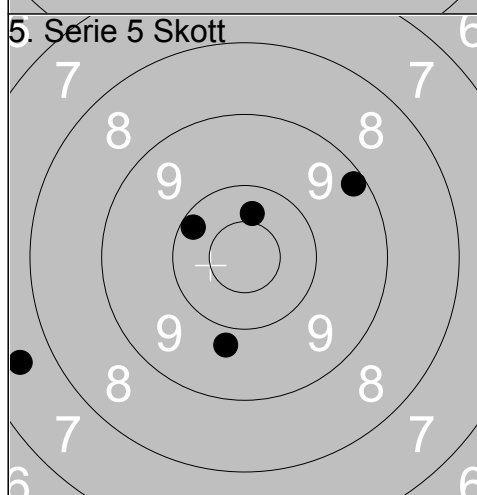

1:	9.2	↗
2:	10.2	↖
3:	10.4	↑
4:	9.8	↘
5:	7.6	↖
Serie		45
Total		235

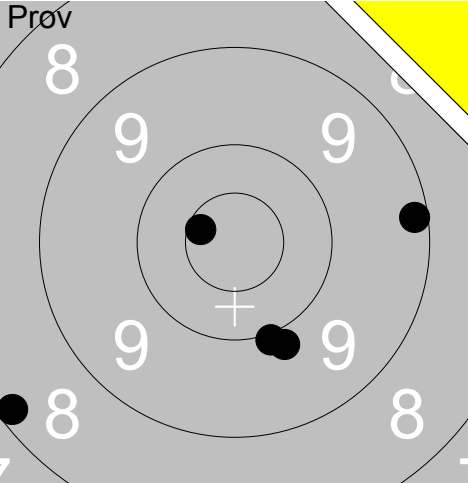
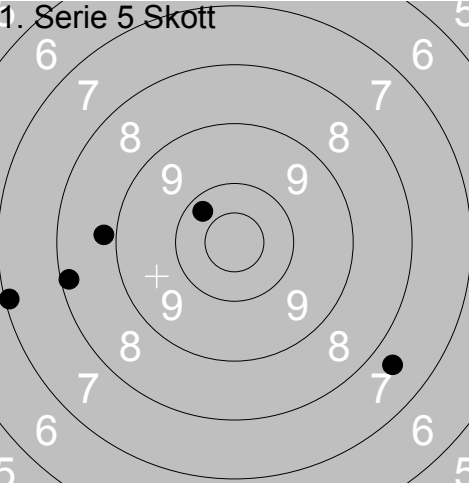
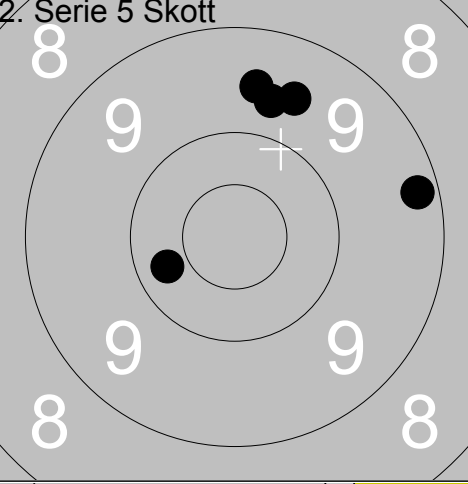
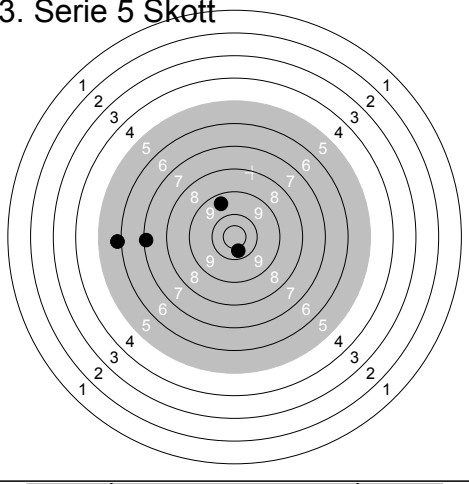
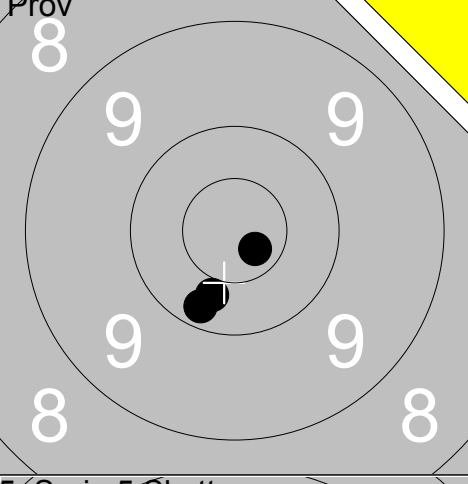
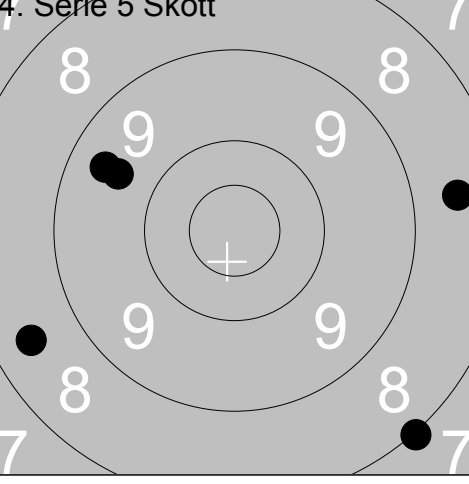
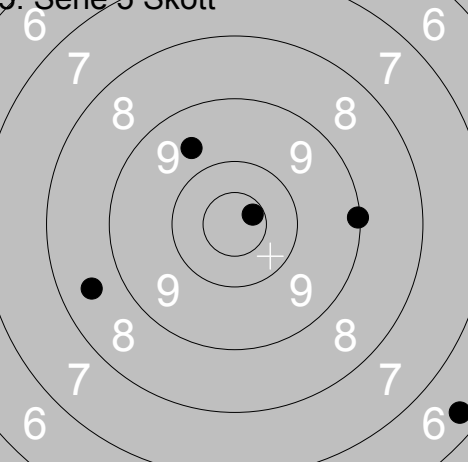
Skjutlag <b>3</b>	Tavla <b>23</b>	<b>Göran Jansson</b>	
Ramselefors	Vaksala	Vet	Up
13.08.2017	SM Banskytte Ställning 2017	Ramselefors SKF	
<b>Prov</b> 	1: 8.2 ↙ 2: 9.9 ↘ 3: 9.2 → 4: 10.0 ↘ 5: 10.6x ↗  Serie 46 Total 0	<b>1. Serie 5 Skott</b> 	1: 8.2 ← 2: 7.1 ← 3: 8.8 ← 4: 7.7 ↘ 5: 10.3 ↗  Serie 40 Total 40
<b>2. Serie 5 Skott</b> 	1: 9.7 ↑ 2: 9.6 ↑ 3: 10.3 ← 4: 9.6 ↑ 5: 9.2 →  Serie 46 Total 86	<b>3. Serie 5 Skott</b> 	1: 5.9 ← 2: 10.4 ↘ 3: 9.5 ↗ 4: 0.0 ↗ 5: 7.1 ←  Serie 31 Total 117
<b>Prov</b> 	1: 10.2 ↘ 2: 10.3 ↘ 3: 10.7x ↘  Serie 30 Total 117	<b>4. Serie 5 Skott</b> 	1: 9.4 ↙ 2: 9.6 ↙ 3: 8.5 ← 4: 8.5 → 5: 8.0 ↘  Serie 42 Total 159
<b>5. Serie 5 Skott</b> 	1: 8.5 ← 2: 9.1 → 3: 10.6x → 4: 6.4 ↘ 5: 9.6 ↗  Serie 42 Total 201		

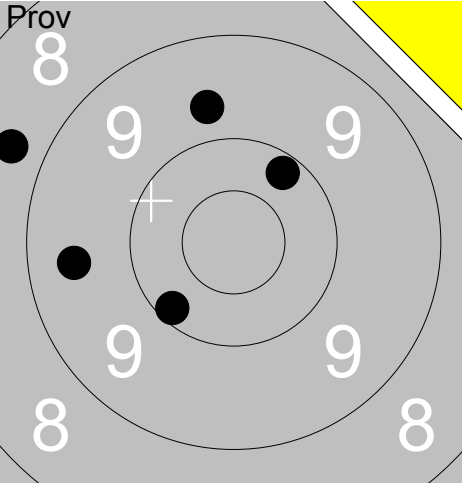
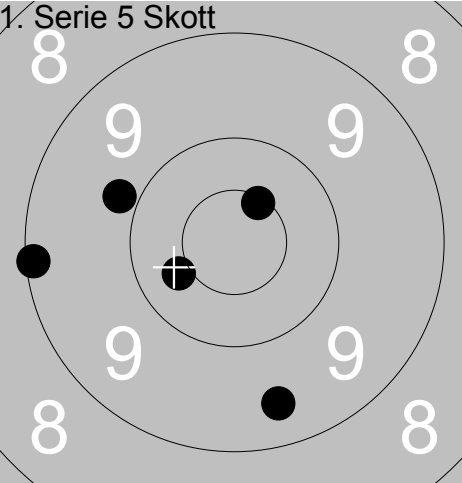
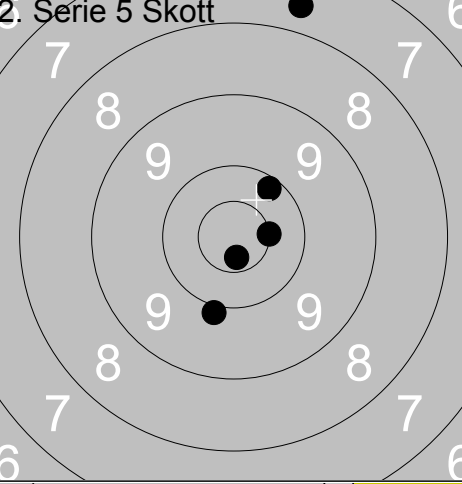
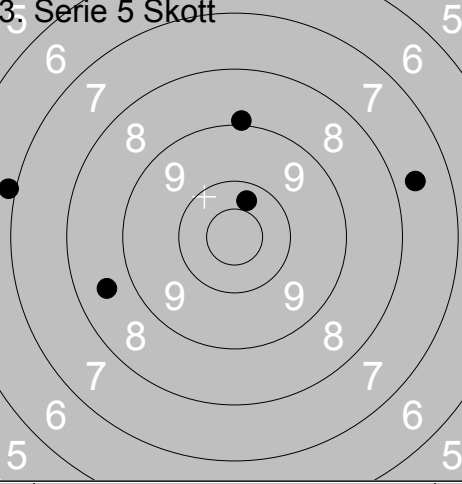
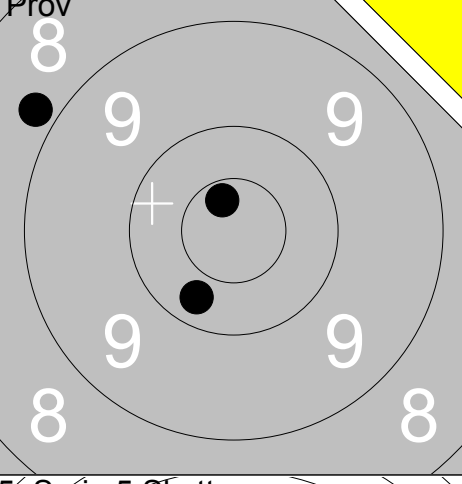
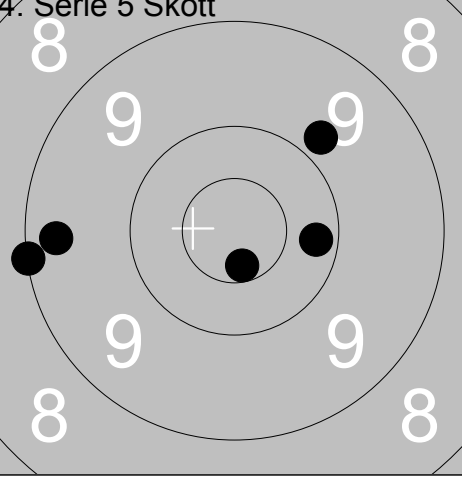
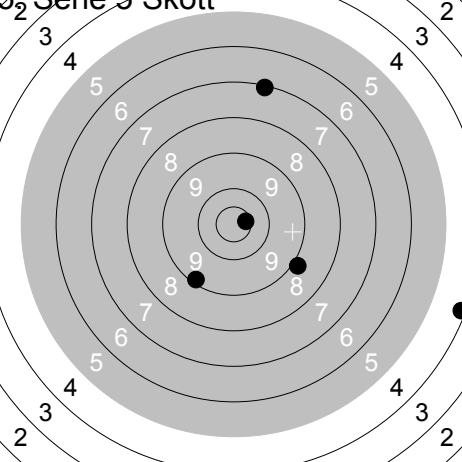

Skjutlag <b>4</b>	Tavla <b>1</b>	<b>Alf Edin</b>			
Ramselefors		Ale		Vet	
13.08.2017		SM Banskytte Ställning 2017		Ramselefors SKF	
Prov		1: 8.7 ↙ 2: 9.7 ↑ 3: 10.2 ↗ 4: 10.1 ↘ 5: 9.5 ←	1. Serie 5 Skott		1: 9.1 ← 2: 9.8 ↙ 3: 10.5x ↗ 4: 10.4 ↘ 5: 9.4 ↓
		Serie 46 Total 0		Serie 47 Total 47	
2. Serie 5 Skott		1: 7.6 ↑ 2: 10.2 ↗ 3: 10.5x → 4: 10.7x ↓ 5: 9.9 ↓	3. Serie 5 Skott		1: 6.9 ← 2: 8.9 ↑ 3: 10.3 ↗ 4: 8.6 ↙ 5: 7.6 →
		Serie 46 Total 93		Serie 39 Total 132	
Prov		1: 8.8 ↙ 2: 10.7x ↑ 3: 10.3 ↘	4. Serie 5 Skott		1: 10.2 → 2: 9.8 ↗ 3: 9.0 ← 4: 10.6x ↓ 5: 9.3 ←
		Serie 28 Total 132		Serie 47 Total 179	
5. Serie 5 Skott		1: 7.1 ↑ 2: 9.2 ↓ 3: 10.6x → 4: 4.2 → 5: 8.9 ↓			
		Serie 38 Total 217			

Skjutlag <b>4</b>	Tavla <b>2</b>	<b>Anna Eklöf</b>	
Ramselefors		Storfors	Öpp Vä
13.08.2017		SM Banskytte Ställning 2017	Ramselefors SKF
Prov		1: 10.4 ↓ 2: 9.8 ↗ 3: 10.6x ← 4: 10.1 ↖ 5: 9.8 ↗	1. Serie 5 Skott  1: 10.1 ↓ 2: 9.8 ↗ 3: 10.3 ↓ 4: 10.6x ↓ 5: 10.1 ↓
		Serie 48 Total 0	Serie 49 Total 49
2. Serie 5 Skott		1: 9.5 ↗ 2: 10.6x ← 3: 10.4 ↖ 4: 10.5x ↓ 5: 10.1 ↓	3. Serie 5 Skott  1: 9.8 ↓ 2: 6.5 ↖ 3: 10.7x ↗ 4: 6.8 → 5: 10.4x ↗
		Serie 49 Total 98	Serie 41 Total 139
Prov		1: 9.9 ↖ 2: 10.0 ↖ 3: 10.7x →	4. Serie 5 Skott  1: 9.9 ↖ 2: 10.6x ↓ 3: 10.7x ↖ 4: 10.4 ↖ 5: 10.7x ←
		Serie 29 Total 139	Serie 49 Total 188
5. Serie 5 Skott		1: 9.4 → 2: 9.7 ↖ 3: 9.9 ↖ 4: 6.3 ← 5: 5.4 ←	
		Serie 38 Total 226	

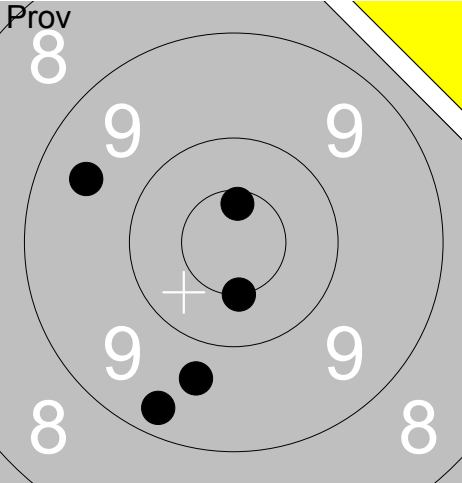
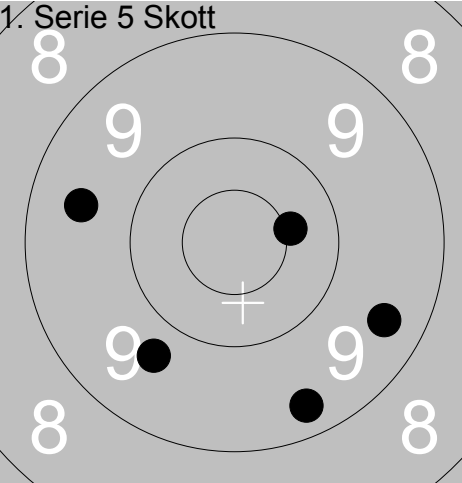
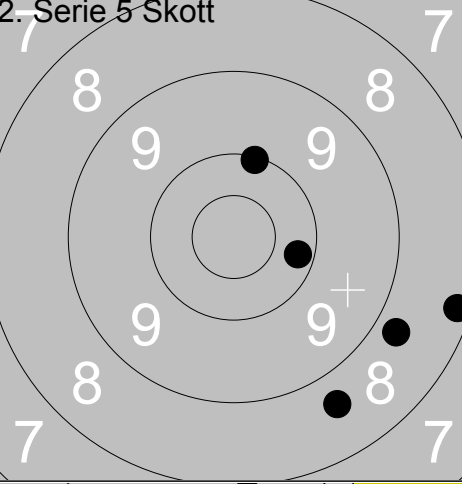
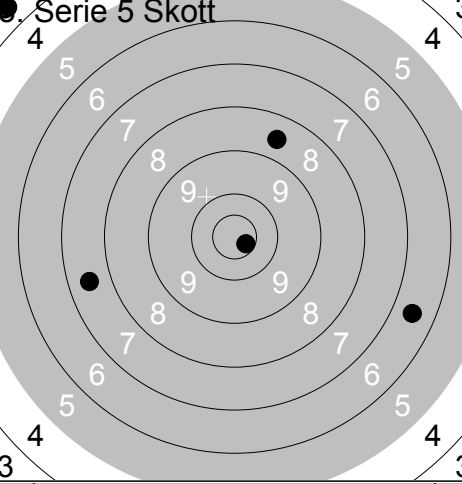
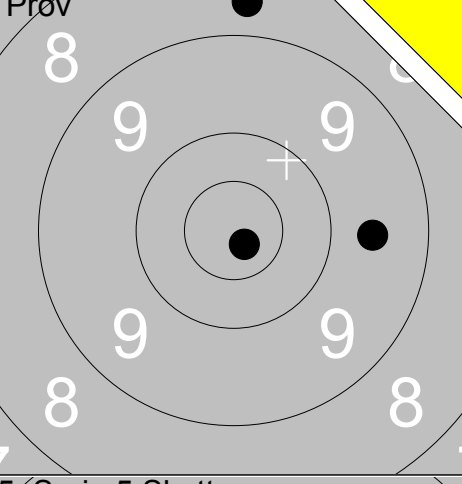
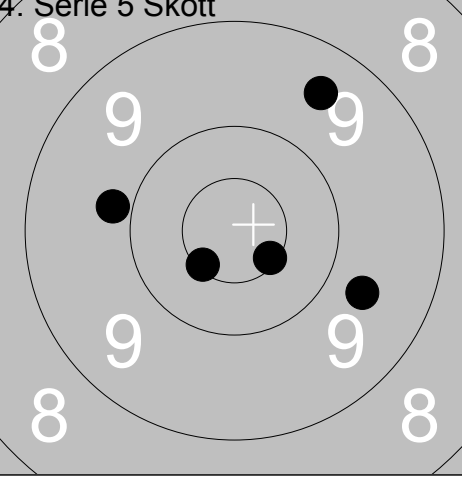
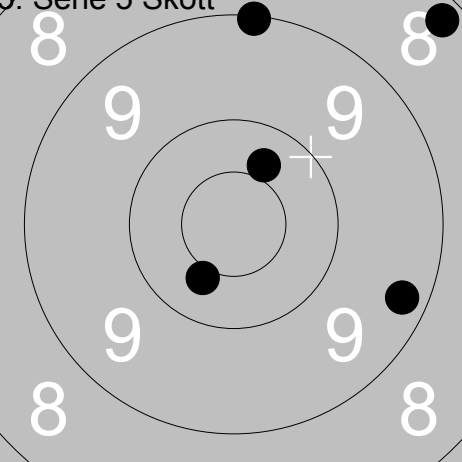
Skjutlag <b>4</b>	Tavla <b>3</b>	<b>Bengt Bengtsson</b>			
Ramselefors		Tyringe		Vet	Sk
13.08.2017		SM Banskytte Ställning 2017		Ramselefors SKF	
Prov		1: 9.3 ↘ 2: 9.5 ↙ 3: 9.7 ↘ 4: 10.6x ↑ 5: 10.5x ↓	1. Serie 5 Skott		1: 9.4 → 2: 9.5 ← 3: 9.7 ↘ 4: 10.4x → 5: 9.3 ↓
		Serie 47 Total 0			Serie 46 Total 46
2. Serie 5 Skott		1: 10.1 ↑ 2: 10.2 → 3: 8.7 ↘ 4: 8.2 → 5: 8.8 ↘	2. Serie 5 Skott		1: 10.7x → 2: 7.5 ← 3: 6.6 → 4: 3.6 ↗ 5: 8.6 ↗
		Serie 44 Total 90			Serie 34 Total 124
Prov		1: 8.7 ↑ 2: 9.6 → 3: 10.8x ↘	3. Serie 5 Skott		1: 10.6x ↘ 2: 9.8 ← 3: 9.5 ↗ 4: 10.5x ↘ 5: 9.7 →
		Serie 27 Total 124			Serie 47 Total 171
5. Serie 5 Skott		1: 10.4 ↘ 2: 9.3 → 3: 8.2 ↗ 4: 9.1 ↑ 5: 10.4 ↗			
		Serie 46 Total 217			

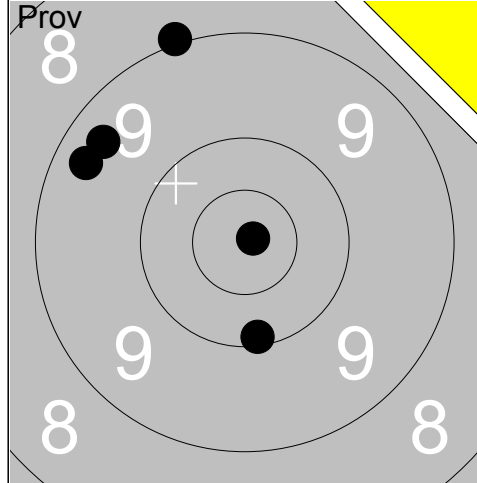

1:	9.0	↗
3:	9.4	↗
4:	10.9x	→
5:	9.3	↖
6:	10.1	↓

Serie	47
Total	0

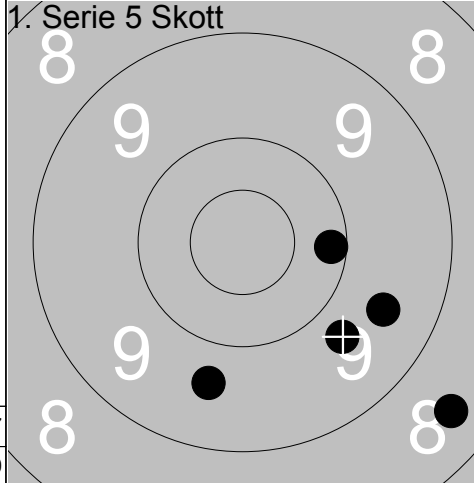

1:	9.7	↘
2:	9.6	↓
3:	8.5	↘
4:	10.2	→
5:	9.5	↘

Serie	45
Total	45

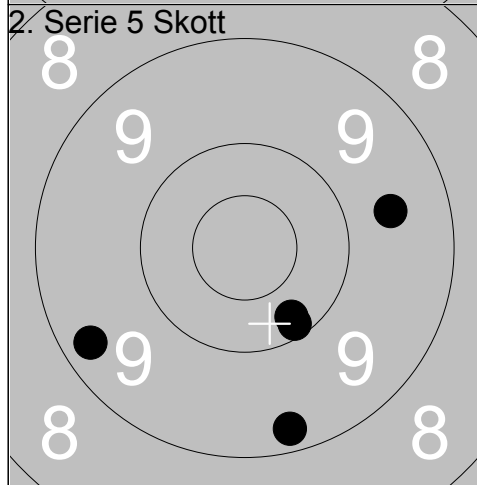

1:	9.6	→
2:	9.2	↓
3:	9.3	↖
4:	10.2	↘
5:	10.1	↘

Serie	47
Total	92

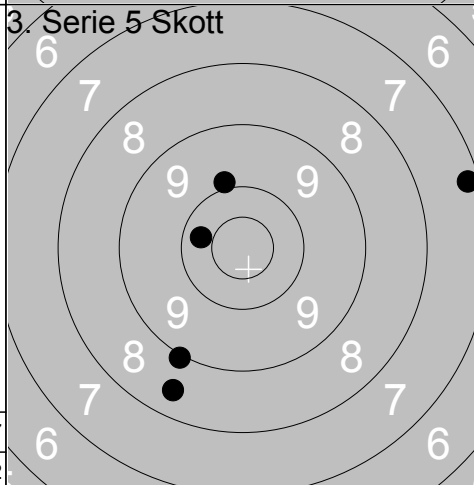

1:	9.0	↘
2:	10.3	↖
3:	9.9	↖
4:	7.2	→
5:	8.5	↘

Serie	43
Total	135

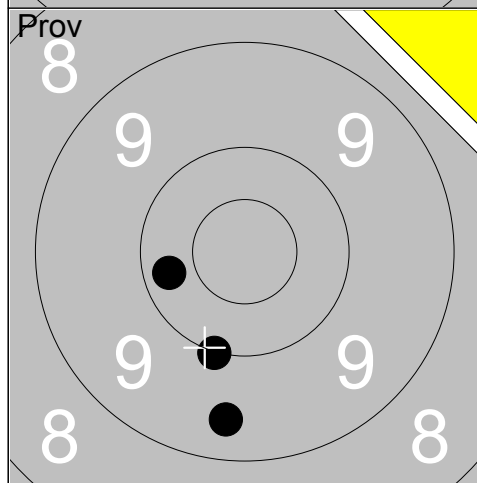

1:	9.4	↓
2:	10.0	↓
3:	10.3	↖

Serie	29
Total	135

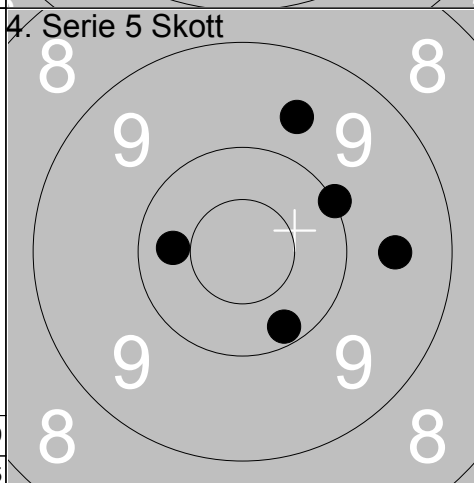

1:	9.6	↗
2:	10.2	↘
3:	9.6	→
4:	10.0	↗
5:	10.3	↖

Serie	48
Total	183

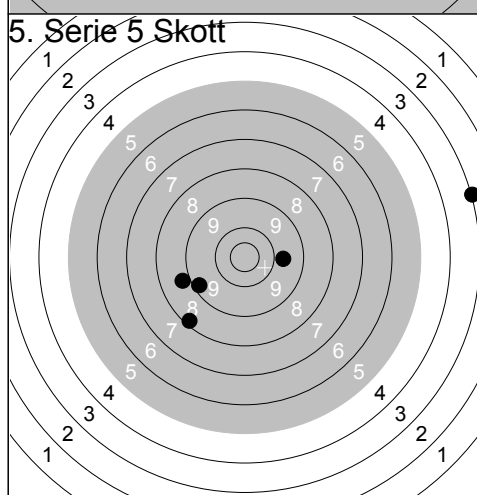

1:	9.7	→
2:	8.8	↖
3:	9.2	↖
4:	3.0	→
5:	8.2	↘

Serie	37
Total	220

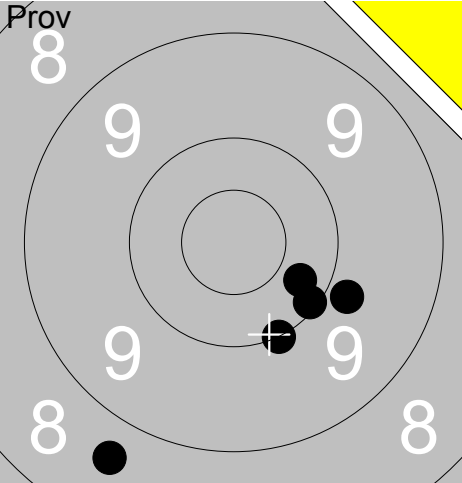
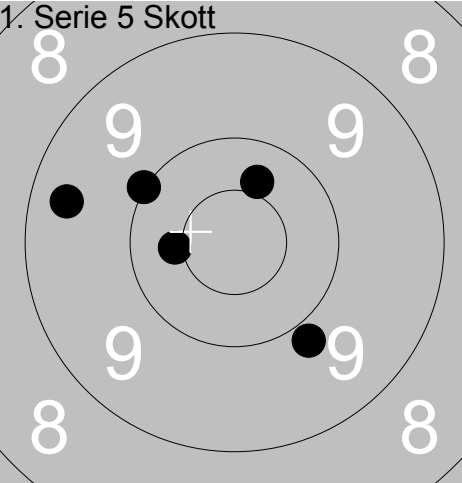
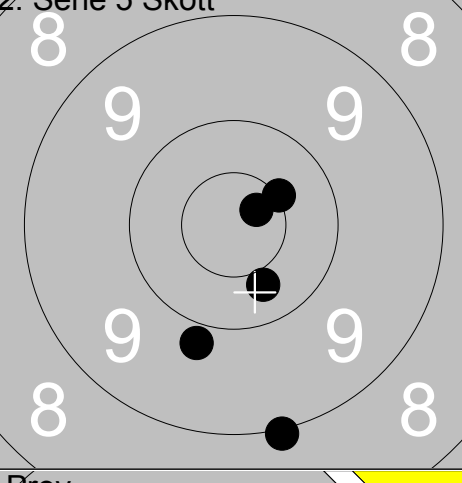
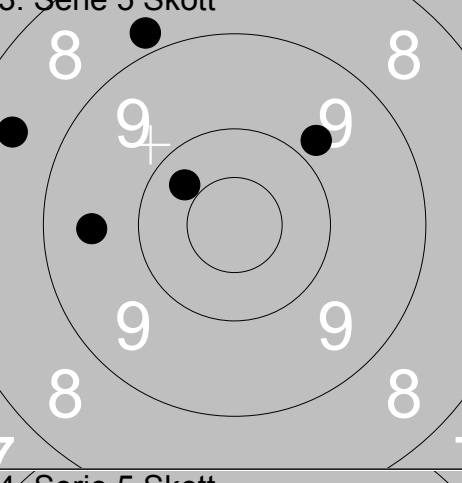
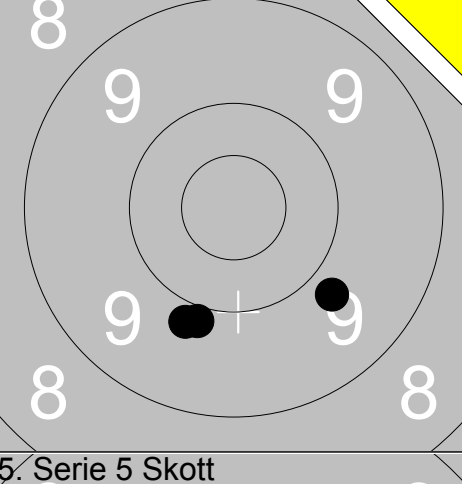
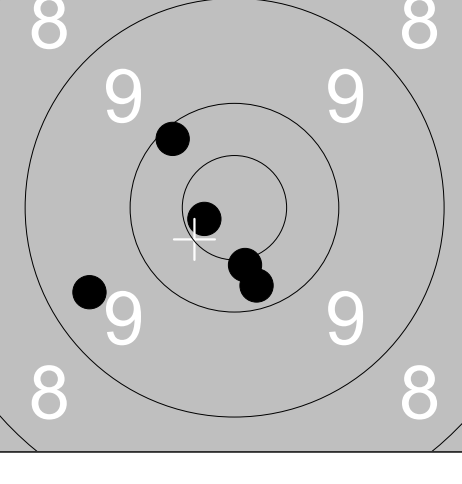
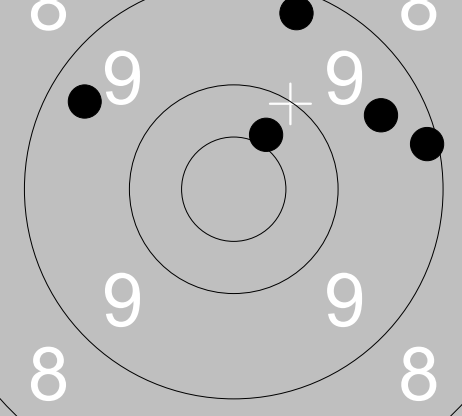
Skjutlag <b>4</b>	Tavla <b>5</b>	<b>Daniel Wallberg</b>		
Ramselefors	Loos	Öpp	Gä	
13.08.2017	SM Banskytte Ställning 2017	Ramselefors SKF		
Prov 	1: 10.1 ↘ 2: 8.7 ↓ 3: 10.0 ↓ 4: 10.3 ↓ 5: 9.8 ↘	1. Serie 5 Skott 	1: 10.0 ↗ 2: 9.4 ← 3: 9.9 ↓ 4: 10.4x ← 5: 10.4 ↗	
	Serie 47 Total 0		Serie 48 Total 48	
2. Serie 5 Skott 	1: 10.5x ↗ 2: 9.0 ↓ 3: 9.9 ↓ 4: 10.7x ↗ 5: 10.4 ↓	3. Serie 5 Skott 	1: 9.5 ← 2: 10.3 ↗ 3: 9.8 ↗ 4: 8.8 ↗ 5: 8.5 ←	
	Serie 48 Total 96		Serie 44 Total 140	
Prov 	1: 9.9 ↓ 2: 9.8 ↓ 3: 9.8 ↓	4. Serie 5 Skott 	1: 10.7x ← 2: 10.2 ↓ 3: 9.4 ← 4: 10.4x ↓ 5: 10.1 ↗	
	Serie 27 Total 140		Serie 49 Total 189	
5. Serie 5 Skott 	1: 9.5 ↗ 2: 9.2 ↗ 3: 9.1 → 4: 10.4 ↗ 5: 9.4 ↗			
	Serie 46 Total 235			

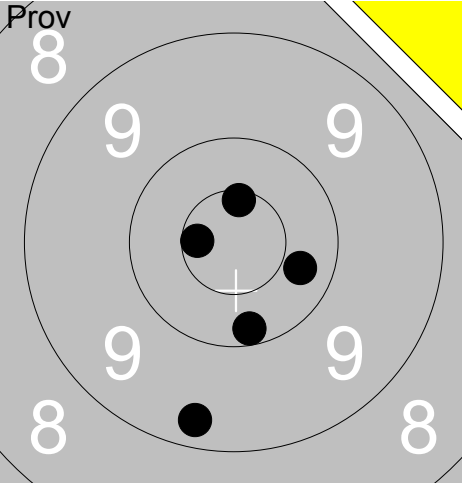
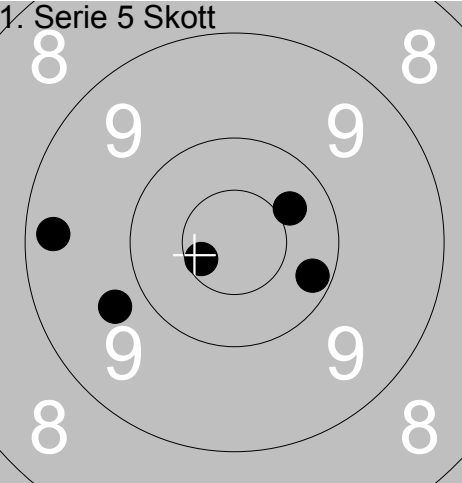
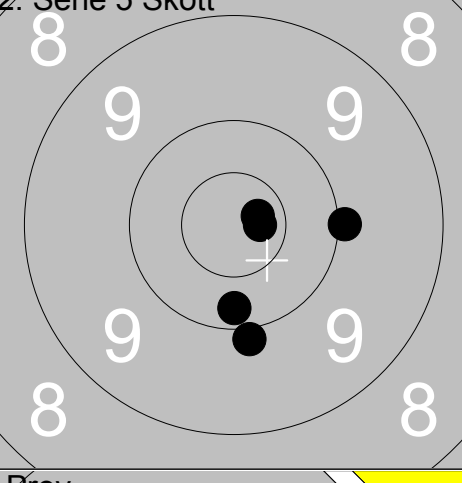
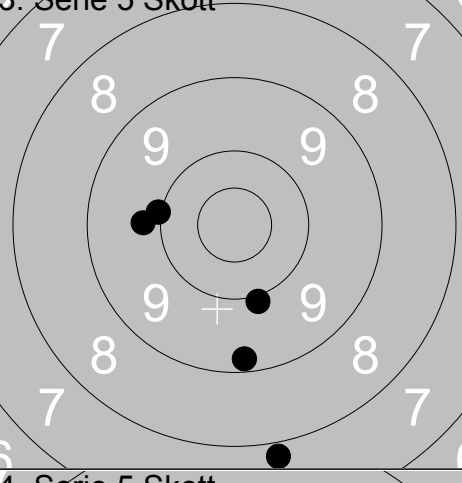
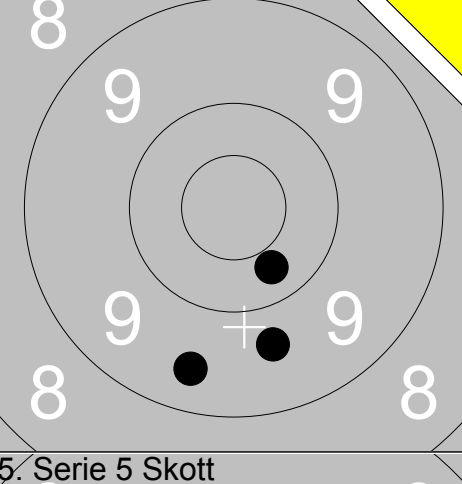
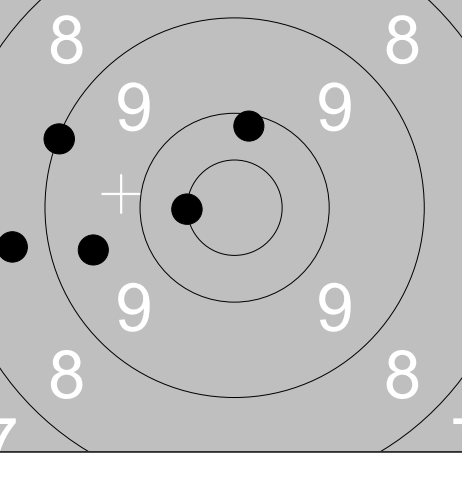
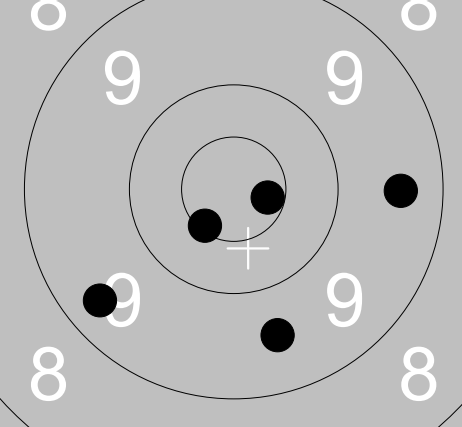
Skjutlag <b>4</b>	Tavla <b>6</b>	<b>Donald Johansson</b>	
Ramselefors	Ale	Vet	No
13.08.2017	SM Banskytte Ställning 2017	Ramselefors SKF	
Prov		1. Serie 5 Skott	
	1: 10.6x ← 2: 9.3 ↓ 3: 10.3 → 4: 10.6x ↑ 5: 10.2 ↓		1: 10.4 ↗ 2: 10.6x ↖ 3: 9.7 ↖ 4: 9.3 ← 5: 10.2 →
	Serie 49 Total 0		Serie 48 Total 48
2. Serie 5 Skott		3. Serie 5 Skott	
	1: 10.2 ↓ 2: 9.9 ↓ 3: 10.0 → 4: 10.7x → 5: 10.7x →		1: 10.0 ↓ 2: 9.8 ← 3: 10.0 ← 4: 9.2 ↓ 5: 7.8 ↓
	Serie 49 Total 97		Serie 45 Total 142
Prov		4. Serie 5 Skott	
	1: 9.4 ↓ 2: 10.3 ↓ 3: 9.7 ↓		1: 10.5x ← 2: 9.0 ↖ 3: 10.1 ↑ 4: 9.5 ← 5: 8.6 ←
	Serie 28 Total 142		Serie 46 Total 188
5. Serie 5 Skott			
	1: 9.4 → 2: 9.6 ↓ 3: 10.6x → 4: 9.4 ↖ 5: 10.5x ↖		
	Serie 47 Total 235		

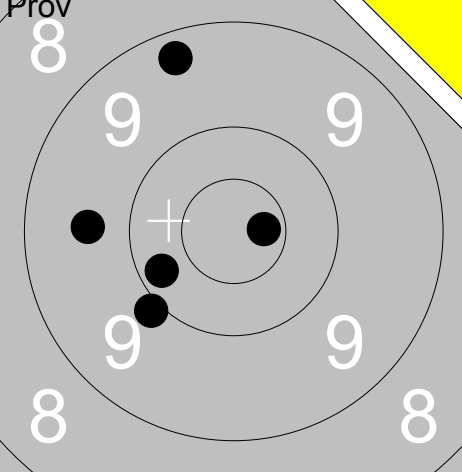
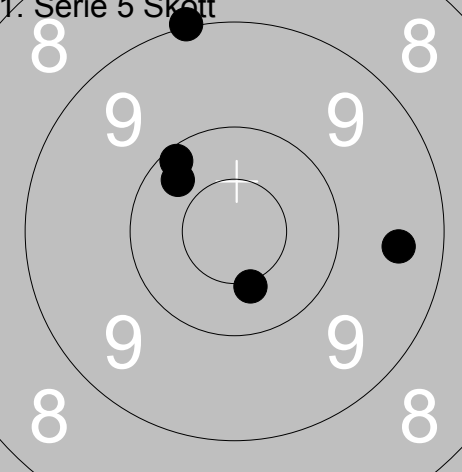
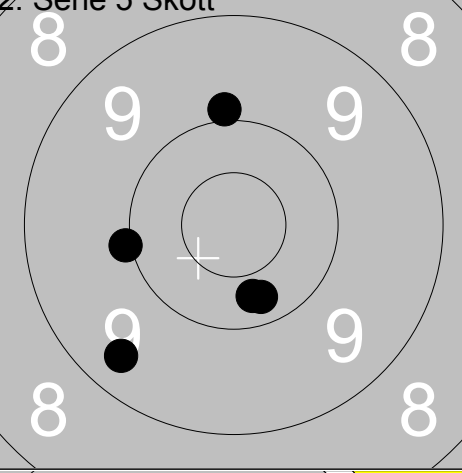
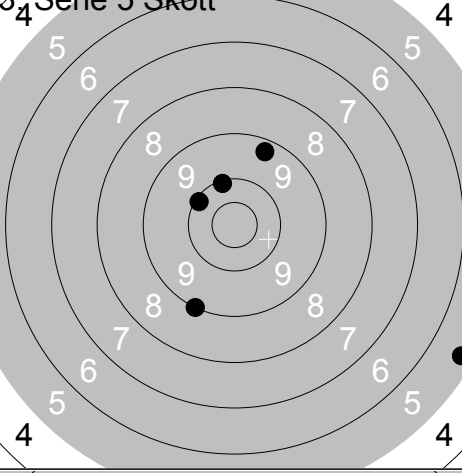
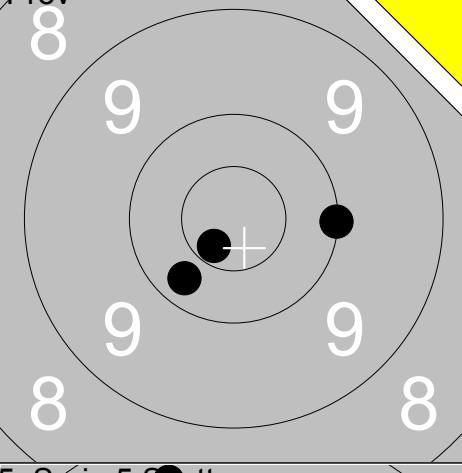
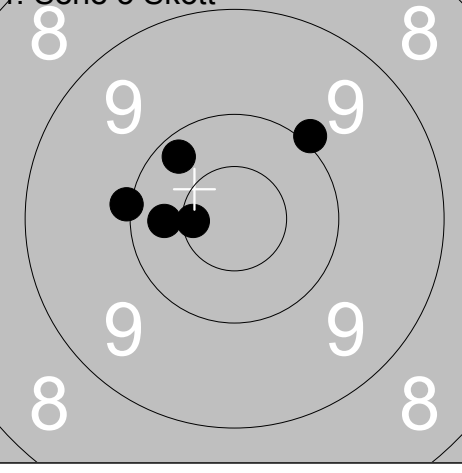
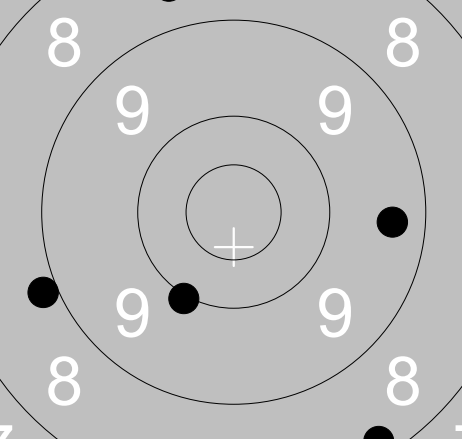
<b>Prov</b> 	1: 10.7x → 2: 10.2 ↙ 3: 9.3 ↗ 4: 9.6 ← 5: 9.9 ↙ <hr/> Serie 47 Total 0	<b>1. Serie 5 Skott</b> 	1: 9.5 → 2: 10.1 ↗ 3: 10.4x ↘ 4: 10.3 ↗ 5: 9.0 ↗ <hr/> Serie 48 Total 48
<b>2. Serie 5 Skott</b> 	1: 10.3 ↘ 2: 10.0 ← 3: 9.4 ↘ 4: 9.9 ↗ 5: 10.3 ↘ <hr/> Serie 48 Total 96	<b>3. Serie 5 Skott</b> 	1: 9.0 ↘ 2: 10.1 ↗ 3: 10.1 ↗ 4: 5.3 ↘ 5: 9.3 ↗ <hr/> Serie 43 Total 139
<b>Prov</b> 	1: 10.7x ↘ 2: 10.3 ↘ 3: 10.0 → <hr/> Serie 30 Total 139	<b>4. Serie 5 Skott</b> 	1: 10.0 ↗ 2: 10.3 ← 3: 10.6x ← 4: 10.2 ↗ 5: 10.0 ← <hr/> Serie 50 Total 189
<b>5. Serie 5 Skott</b> 	1: 10.0 ↘ 2: 8.9 ← 3: 9.4 → 4: 8.2 ↘ 5: 8.6 ↗ <hr/> Serie 43 Total 232		

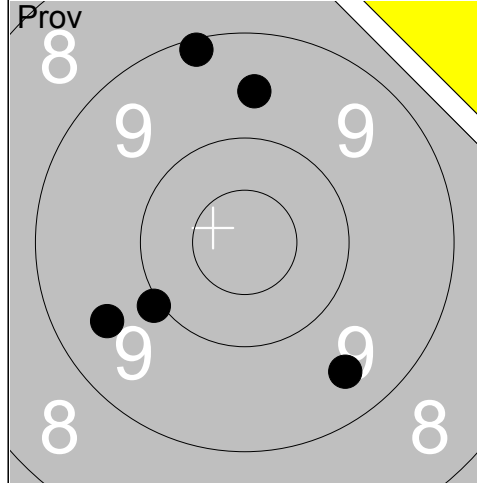

1:	9.1	↑
2:	9.6	↑
3:	9.5	↙
4:	10.0	↙
5:	9.5	↘
Serie		46
Total		0

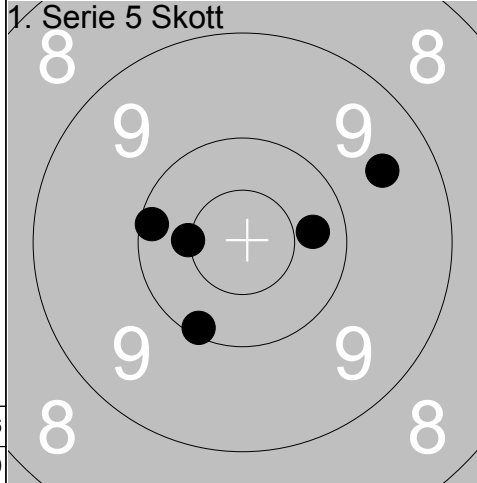

1:	10.3	→
2:	10.1	↓
3:	9.5	→
4:	10.1	↙
5:	10.5x	←
Serie		49
Total		49

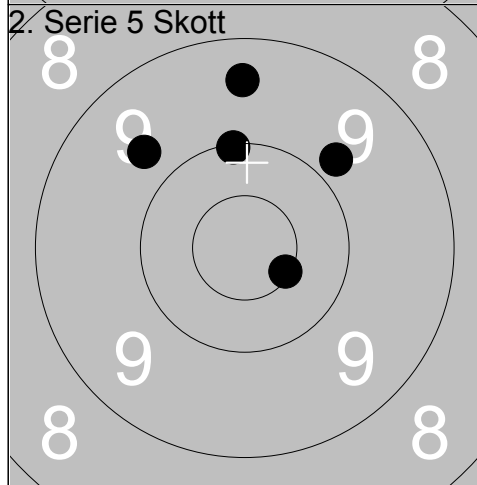

1:	10.5x	→
2:	10.1	↑
3:	9.7	↖
4:	9.4	↑
5:	9.8	↗
Serie		47
Total		96

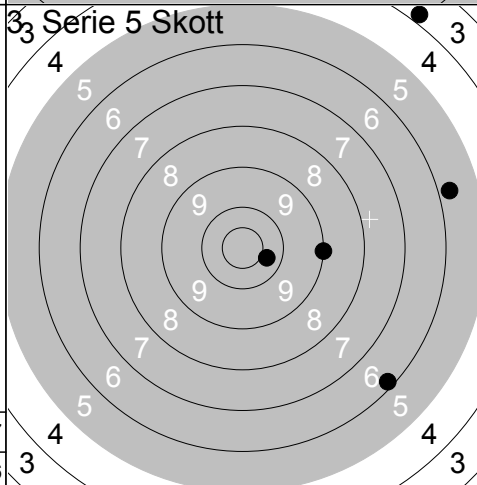

1:	9.0	→
2:	5.7	→
3:	10.4	→
4:	3.8	↗
5:	6.2	↘
Serie		33
Total		129

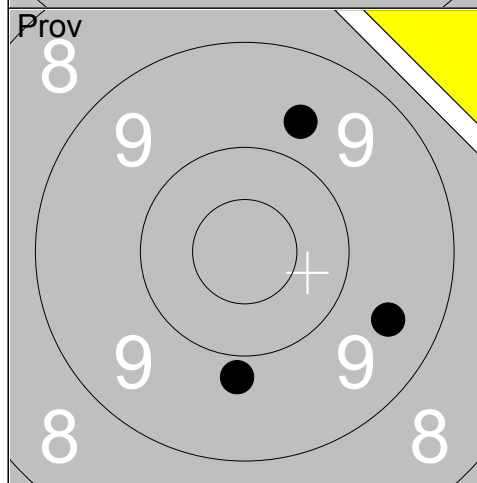

1:	9.7	↗
2:	9.5	→
3:	9.8	↓
Serie		27
Total		129

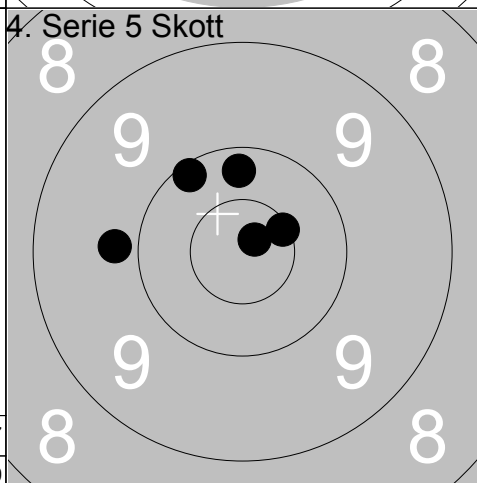

1:	10.8x	↗
2:	10.2	↑
3:	10.5x	↗
4:	10.1	↖
5:	9.8	←
Serie		49
Total		178

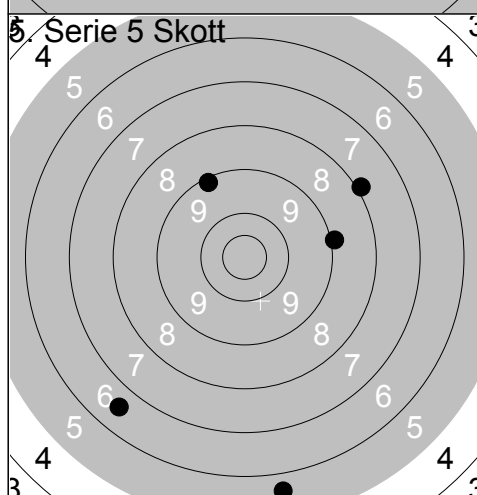

1:	7.9	↗
2:	9.1	↖
3:	8.9	→
4:	5.6	↓
5:	6.6	↙
Serie		35
Total		213



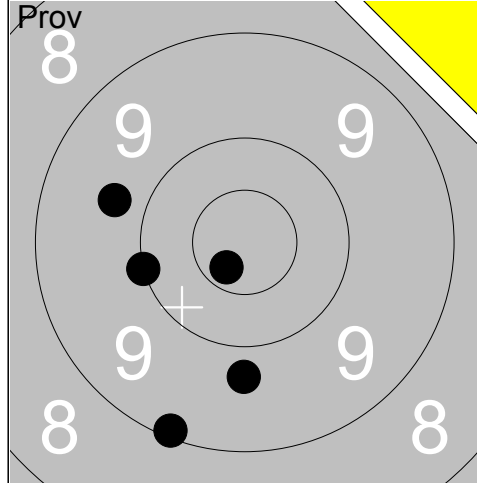

1:	9.7	↓
2:	10.0	←
3:	10.7x	↓
4:	9.1	↓
5:	9.7	←
Serie		47
Total		0

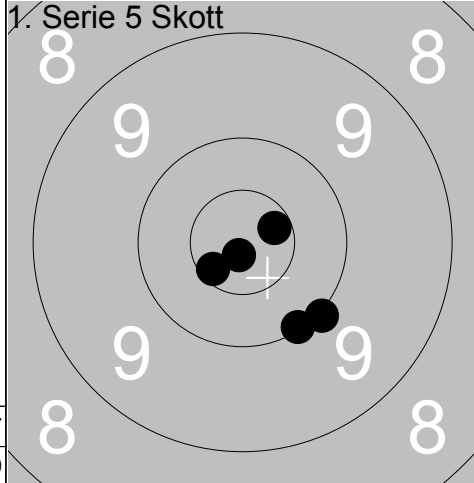

1:	10.0	↓
2:	10.8x	↓
3:	10.6x	→
4:	10.6x	←
5:	10.1	↓
Serie		50
Total		50

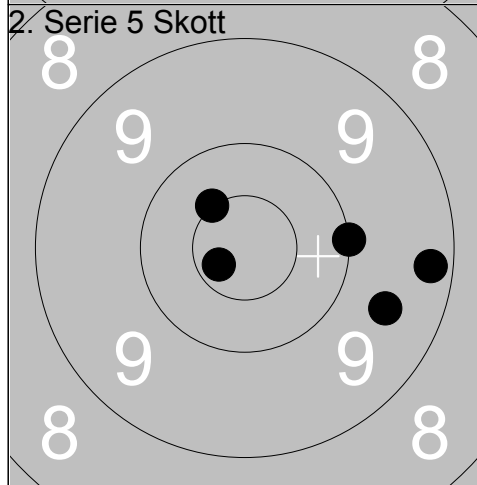

1:	10.0	→
2:	10.5x	↗
3:	10.7x	←
4:	9.6	↘
5:	9.2	→
Serie		48
Total		98

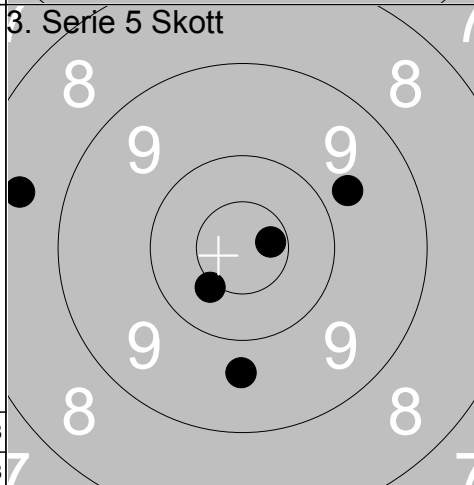

1:	9.7	↓
2:	10.7x	→
3:	8.5	←
4:	10.4x	↓
5:	9.7	→
Serie		46
Total		144

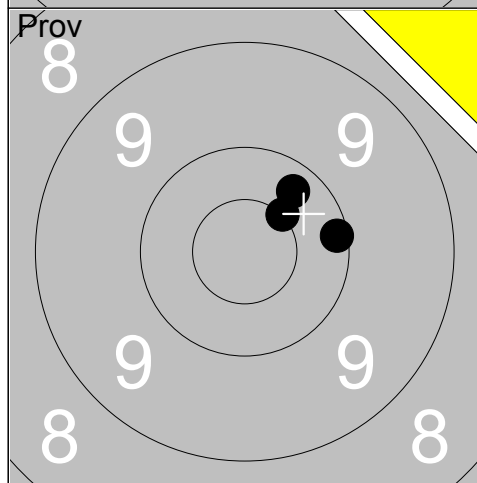

1:	10.3	↗
2:	10.1	→
3:	10.5x	↗
Serie		30
Total		144

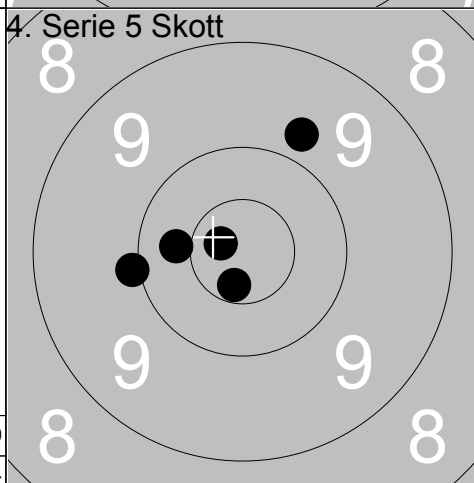

1:	9.8	↗
2:	10.7x	←
3:	10.0	←
4:	10.4	←
5:	10.6x	↓
Serie		49
Total		193

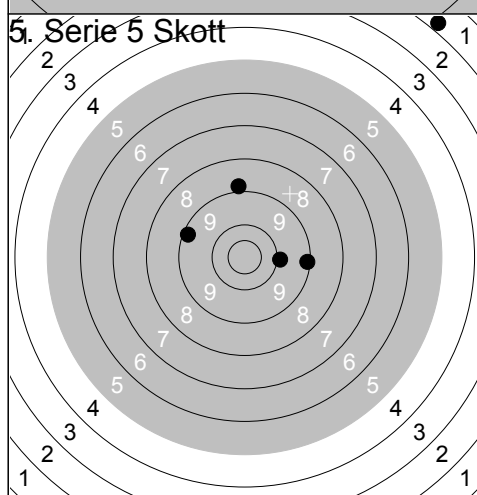

1:	8.9	↑
2:	9.9	→
3:	9.2	←
4:	9.1	→
5:	1.8	↗
Serie		36
Total		229

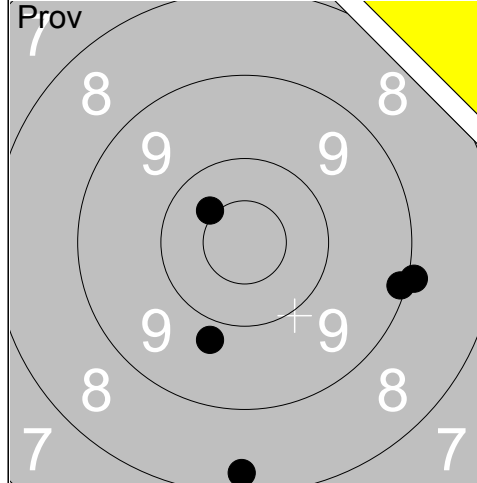

1:	9.1	→
2:	10.4x	↗
3:	9.0	→
4:	8.3	↓
5:	9.8	↓
Serie		45
Total		0

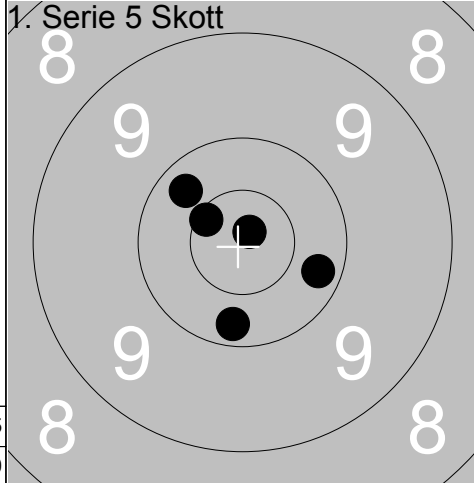

1:	10.6x	↖
2:	10.2	→
3:	10.2	↓
4:	10.8x	↗
5:	10.3	↗
Serie		50
Total		50

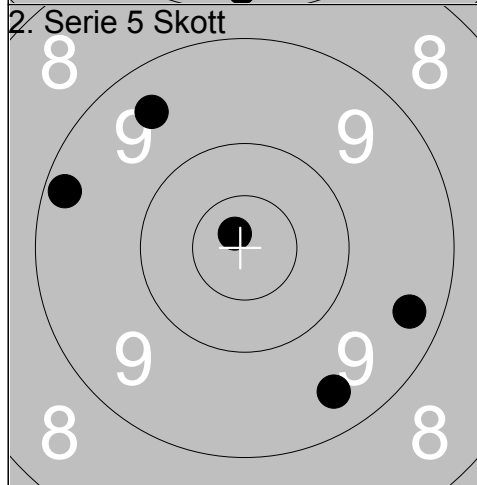

1:	9.2	←
2:	9.5	↗
3:	10.8x	↗
4:	9.3	↓
5:	9.4	↘
Serie		46
Total		96

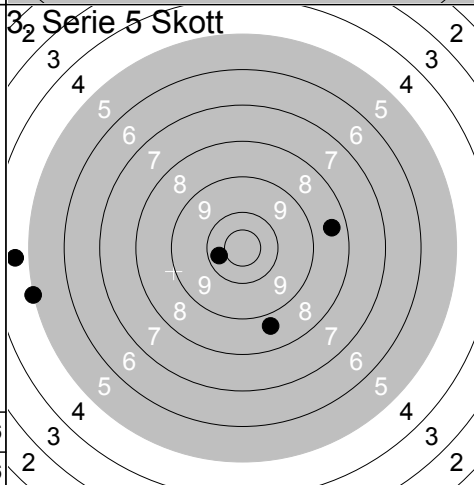

1:	10.3	←
2:	8.7	↓
3:	4.6	←
4:	5.0	←
5:	8.5	→
Serie		35
Total		131

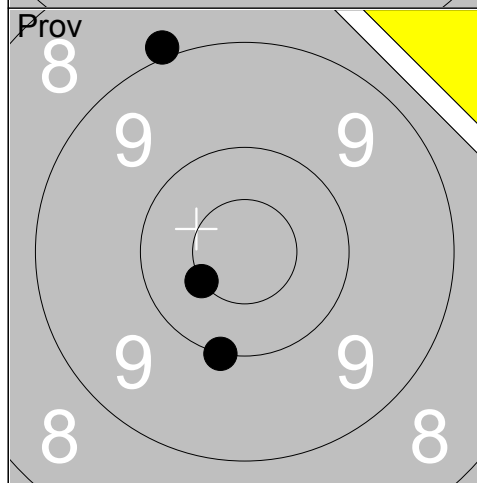

1:	10.5x	↖
2:	10.0	↓
3:	8.9	↗
Serie		28
Total		131

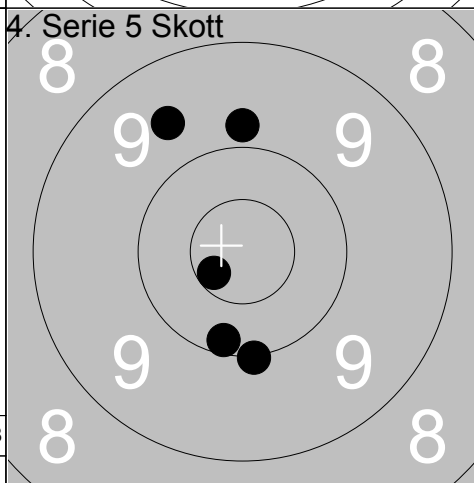

1:	10.2	↓
2:	10.0	↓
3:	9.8	↑
4:	10.6x	↖
5:	9.6	↗
Serie		48
Total		179

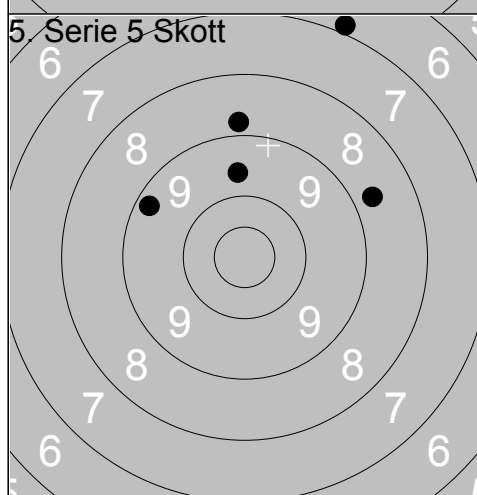

1:	8.7	→
2:	9.6	↑
3:	9.3	↖
4:	6.9	↗
5:	8.8	↑
Serie		40
Total		219

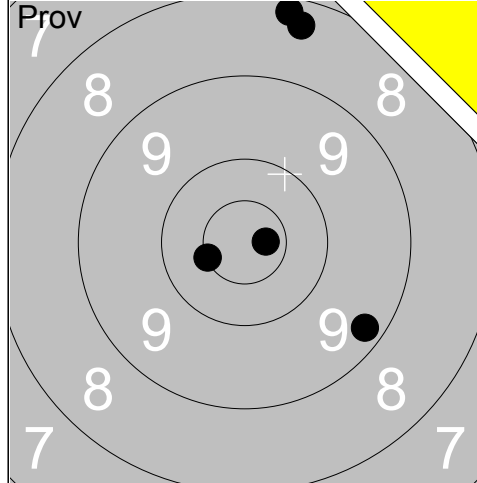

1:	8.2	↑
2:	8.3	↑
3:	10.5x	←
4:	9.3	↘
5:	10.7x	→
Serie		45
Total		0

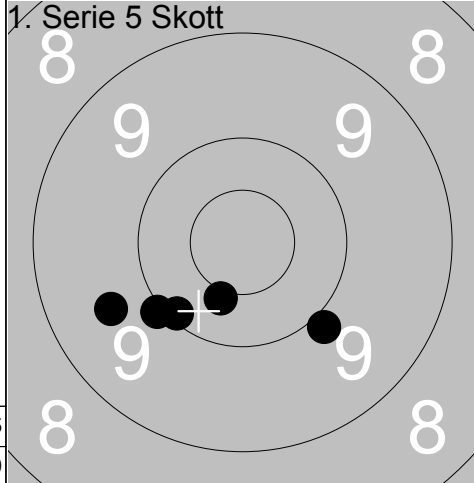

1:	10.0	↙
2:	10.4x	↘
3:	9.9	↘
4:	10.1	↙
5:	9.6	↙
Serie		48
Total		48

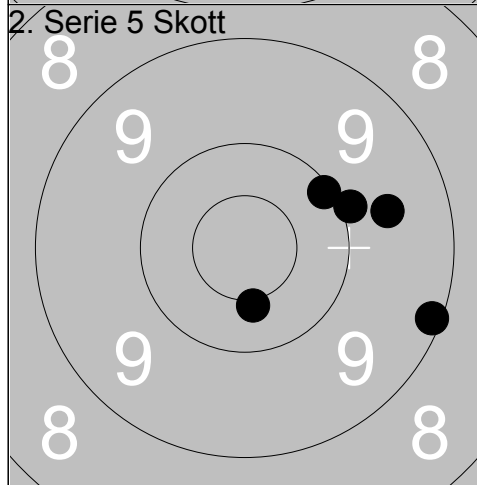

1:	10.1	↗
2:	9.9	→
3:	10.4x	↘
4:	9.1	↗
5:	9.6	→
Serie		47
Total		95

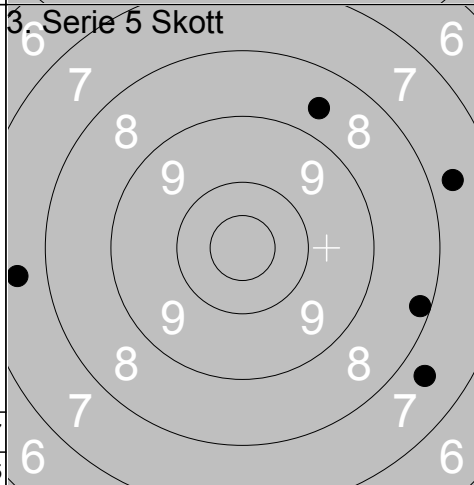

1:	7.6	←
2:	8.2	→
3:	7.6	↘
4:	8.6	↗
5:	7.7	→
Serie		37
Total		132

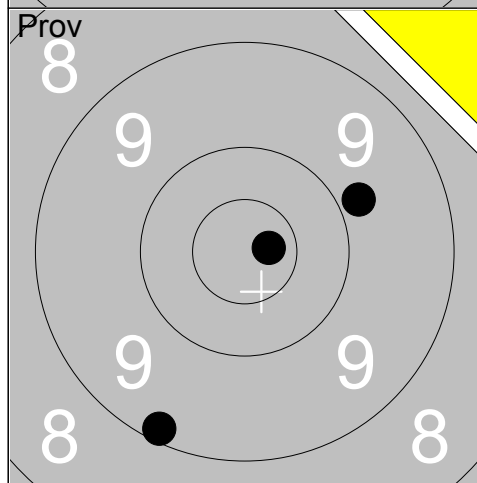

1:	9.8	↗
2:	10.7x	→
3:	9.1	↘
Serie		28
Total		132

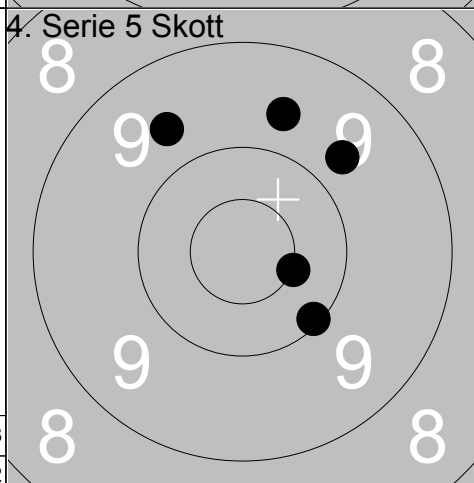

1:	10.5x	→
2:	9.7	↗
3:	9.7	↗
4:	9.7	↗
5:	10.1	↘
Serie		47
Total		179

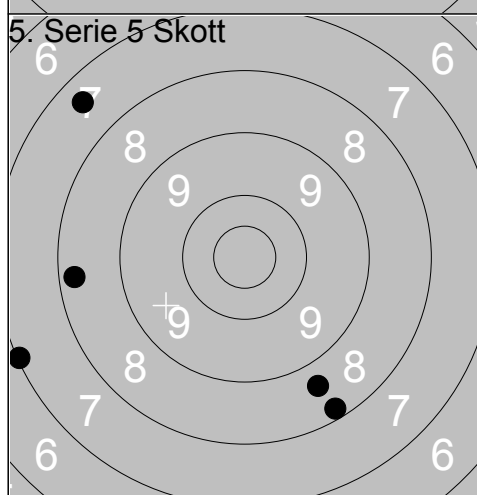

1:	8.7	↘
2:	8.2	↘
3:	8.3	←
4:	7.4	↗
5:	7.1	↙
Serie		38
Total		217

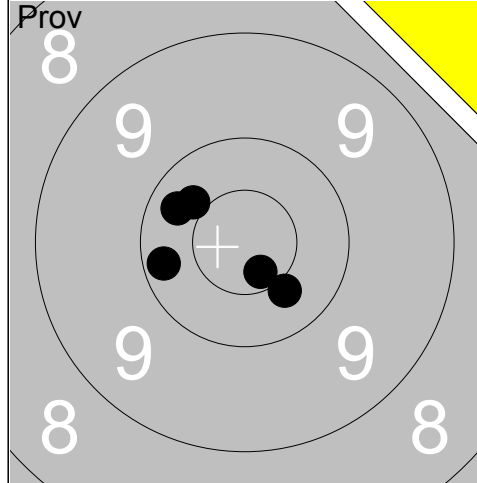

1:	10.4	↘
2:	10.7x	↘
3:	10.2	←
4:	10.3	↗
5:	10.4	↗
Serie		50
Total		0

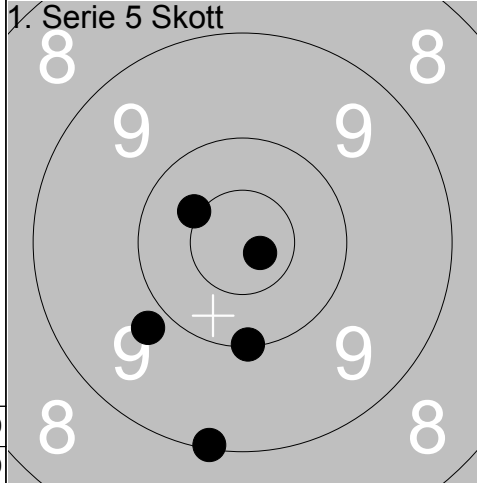

1:	10.0	↓
2:	10.4x	↖
3:	9.1	↓
4:	10.8x	↘
5:	9.8	↙
Serie		48
Total		48

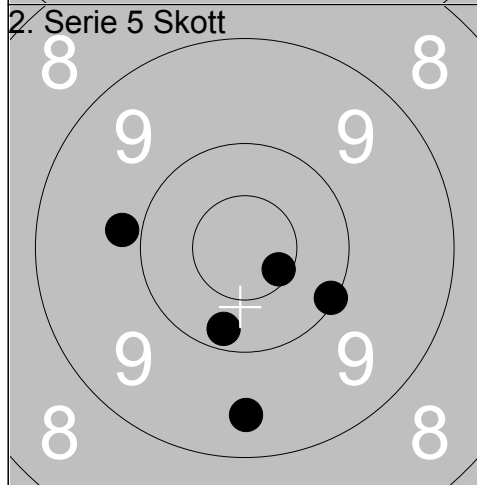

1:	10.1	↘
2:	9.4	↓
3:	9.8	←
4:	10.2	↓
5:	10.6x	↘
Serie		48
Total		96

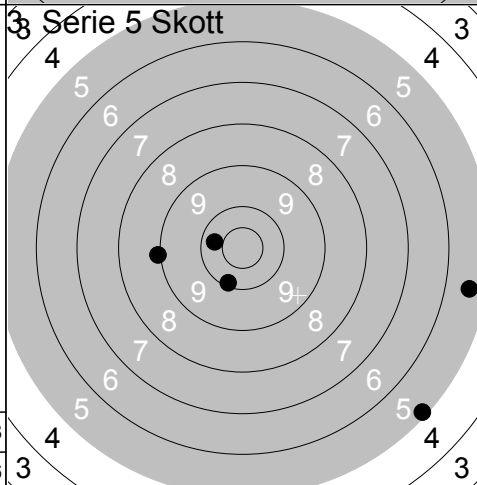

1:	9.0	←
2:	10.1	↓
3:	10.3	←
4:	5.5	→
5:	5.1	↘
Serie		39
Total		135

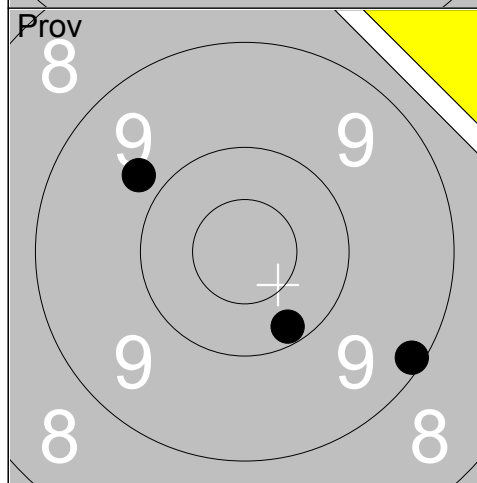

1:	9.8	↗
2:	10.2	↘
3:	9.1	↘
Serie		28
Total		135

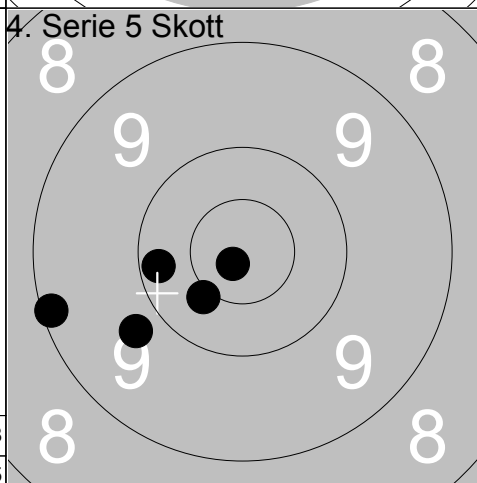

1:	10.8x	↙
2:	10.2	←
3:	9.1	←
4:	10.4x	↙
5:	9.8	↙
Serie		48
Total		183

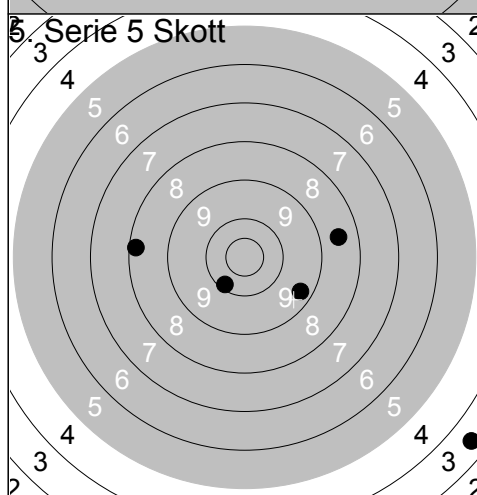

1:	8.2	←
2:	10.1	↙
3:	8.5	→
4:	3.5	↘
5:	9.3	↘
Serie		38
Total		221

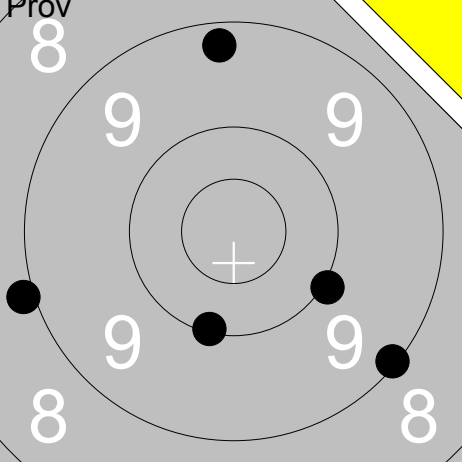
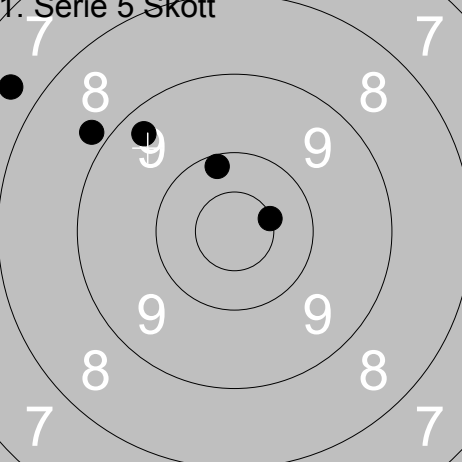
<p>Prov</p> 	<p>1: 9.2 ↑</p> <p>2: 10.0 →</p> <p>3: 9.1 →</p> <p>4: 8.9 ←</p> <p>5: 10.1 ↓</p>	<p>1. Serie 5 Skott</p> 	<p>1: 10.5x →</p> <p>2: 10.2 ↑</p> <p>3: 8.8 ↗</p> <p>4: 7.6 ↗</p> <p>5: 9.3 ↗</p>
Serie 46	Total 0	Serie 44	Total 44

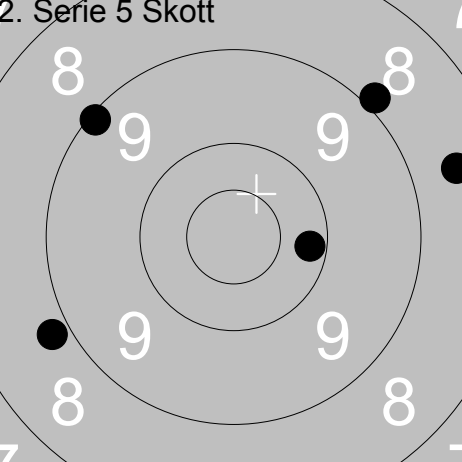
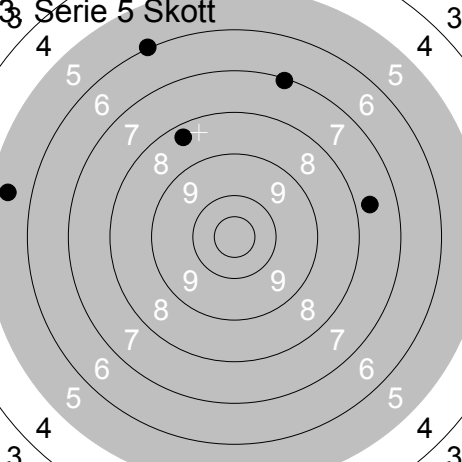
<p>2. Serie 5 Skott</p> 	<p>1: 9.1 ↗</p> <p>2: 8.9 ↗</p> <p>3: 8.5 →</p> <p>4: 10.2 →</p> <p>5: 8.8 ←</p>	<p>3. Serie 5 Skott</p> 	<p>1: 5.5 ←</p> <p>2: 8.3 ↗</p> <p>3: 7.7 →</p> <p>4: 7.1 ↑</p> <p>5: 6.0 ↑</p>
Serie 43	Total 87	Serie 33	Total 120

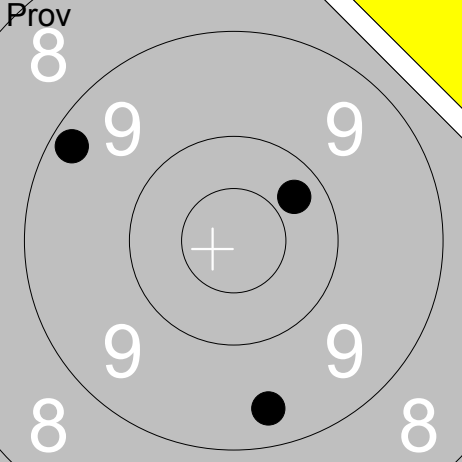
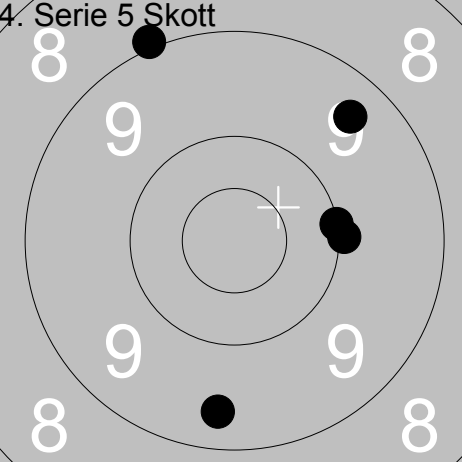
<p>Prov</p> 	<p>1: 9.2 ↗</p> <p>2: 9.4 ↓</p> <p>3: 10.3 ↗</p>	<p>4. Serie 5 Skott</p> 	<p>1: 9.0 ↗</p> <p>2: 9.4 ↗</p> <p>3: 9.4 ↓</p> <p>4: 10.0 →</p> <p>5: 10.0 →</p>
Serie 28	Total 120	Serie 47	Total 167

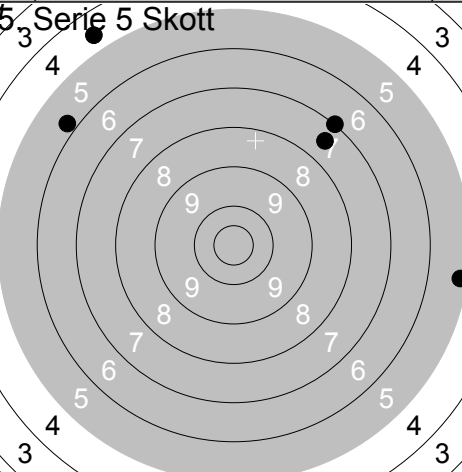
<p>5. Serie 5 Skott</p> 	<p>1: 4.6 ↗</p> <p>2: 5.8 ↗</p> <p>3: 7.5 ↗</p> <p>4: 7.0 ↗</p> <p>5: 5.2 →</p>		
Serie 28	Total 195		

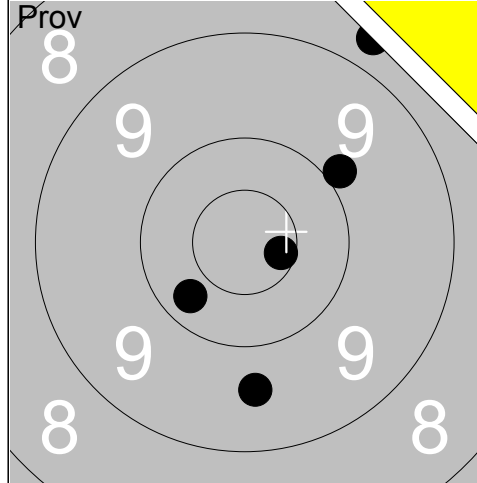

1:	8.7	↗
2:	9.9	↘
3:	10.3	↙
4:	10.6x	→
5:	9.6	↓
Serie		46
Total		0

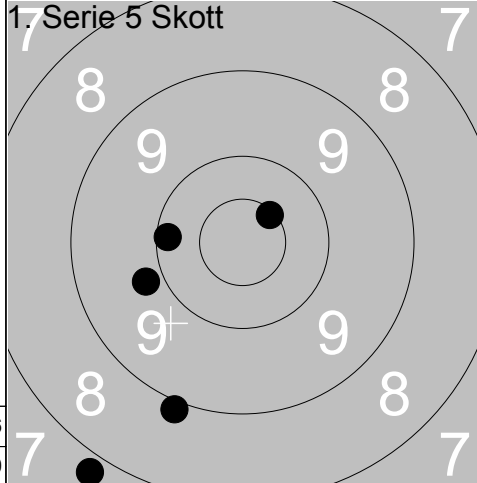

1:	10.5x	↗
2:	9.8	↙
3:	10.1	←
4:	8.9	↓
5:	7.8	↙
Serie		44
Total		44

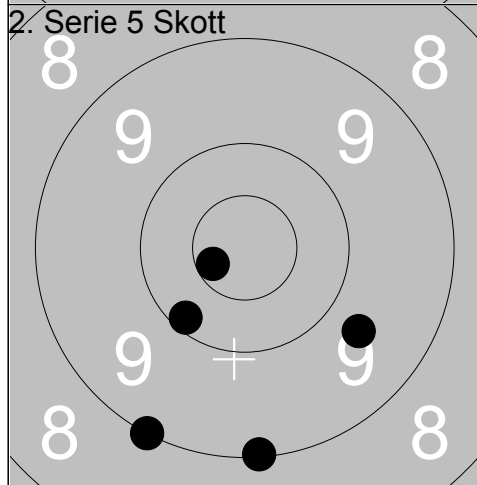

1:	10.6x	↙
2:	9.0	↙
3:	10.1	↙
4:	9.0	↓
5:	9.7	↘
Serie		47
Total		91

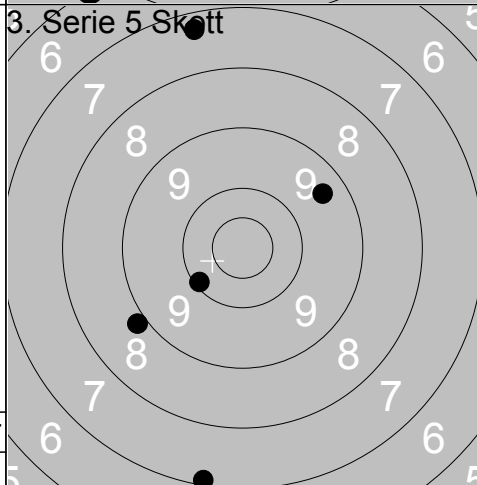

1:	9.4	↗
2:	8.9	↙
3:	10.1	↙
4:	7.1	↓
5:	7.3	↑
Serie		41
Total		132

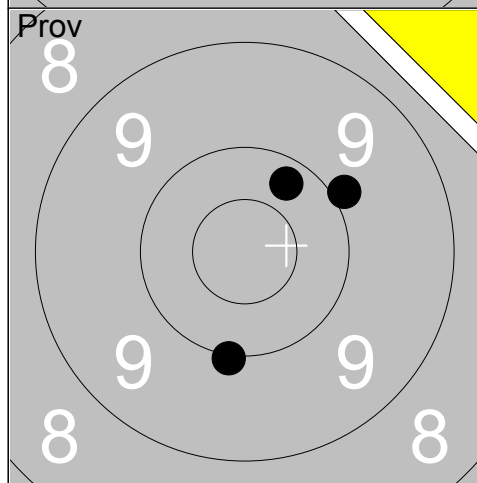

1:	10.2	↗
2:	9.9	↘
3:	10.0	↓
Serie		29
Total		132

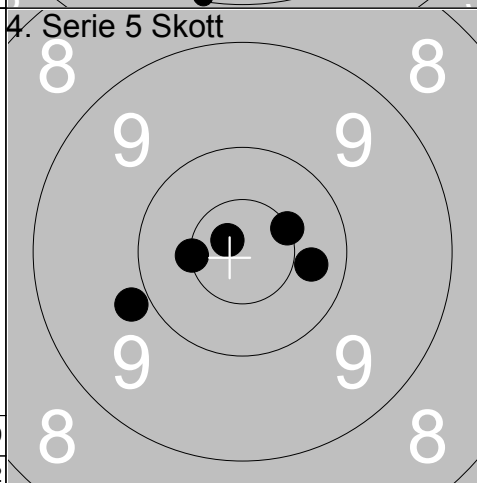

1:	10.3	→
2:	10.5x	↗
3:	9.9	↙
4:	10.8x	↖
5:	10.5x	←
Serie		49
Total		181

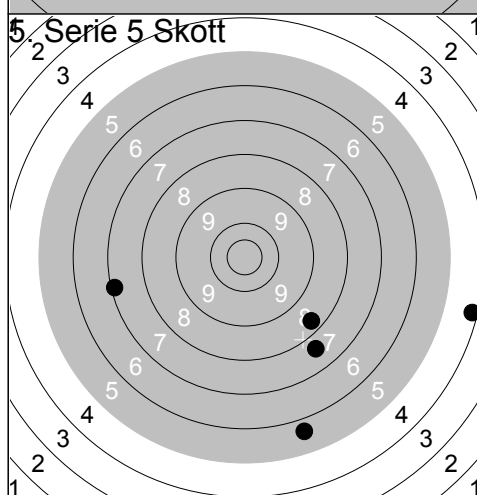

1:	4.2	→
2:	7.7	↙
3:	8.3	↙
4:	5.7	↙
5:	7.1	←
Serie		31
Total		212

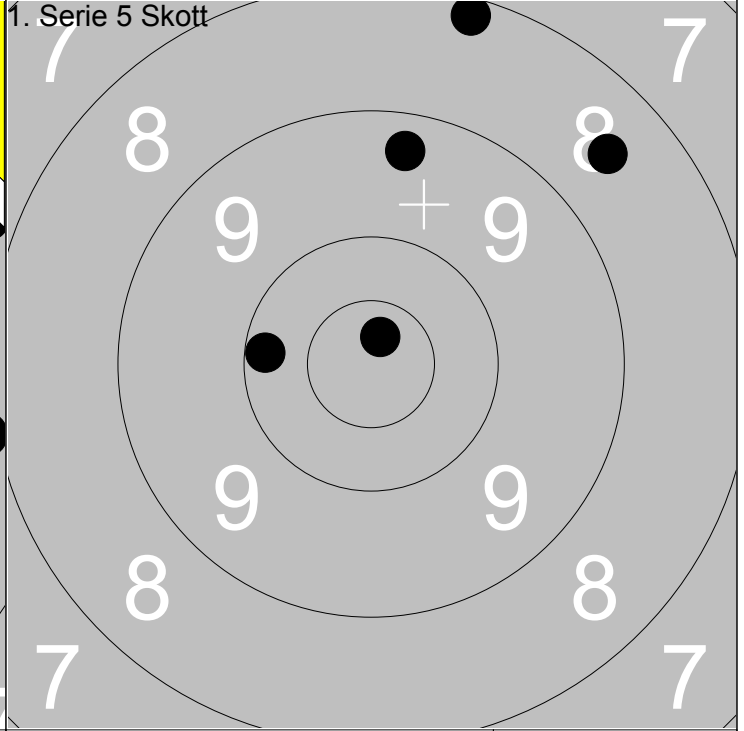
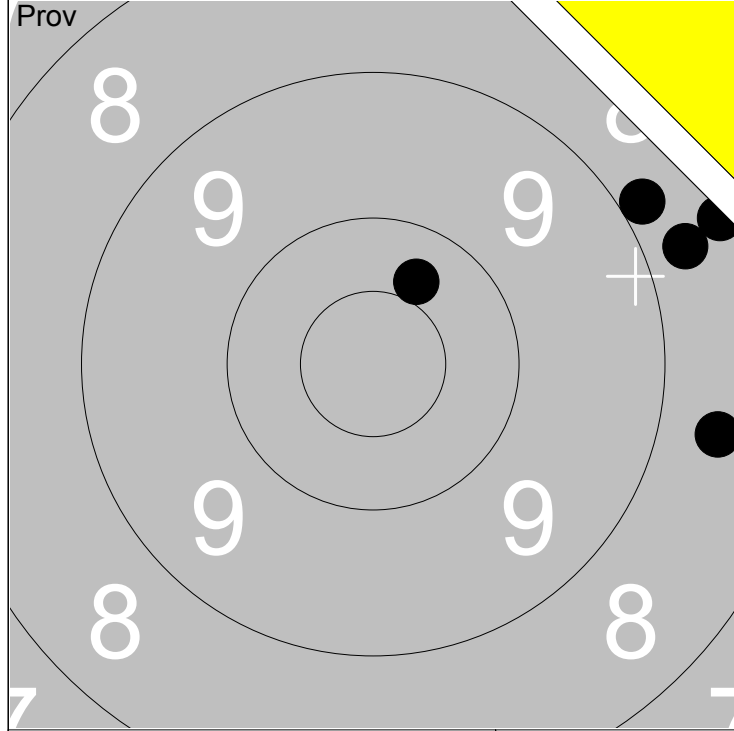

1:	10.4	↗
2:	8.4	→
3:	8.9	↗
4:	8.7	→
5:	8.6	→

Serie	42
Total	0

1:	10.7x	↗
2:	8.5	↗
3:	10.2	←
4:	8.2	↗
5:	9.3	↗

Serie	45
Total	45

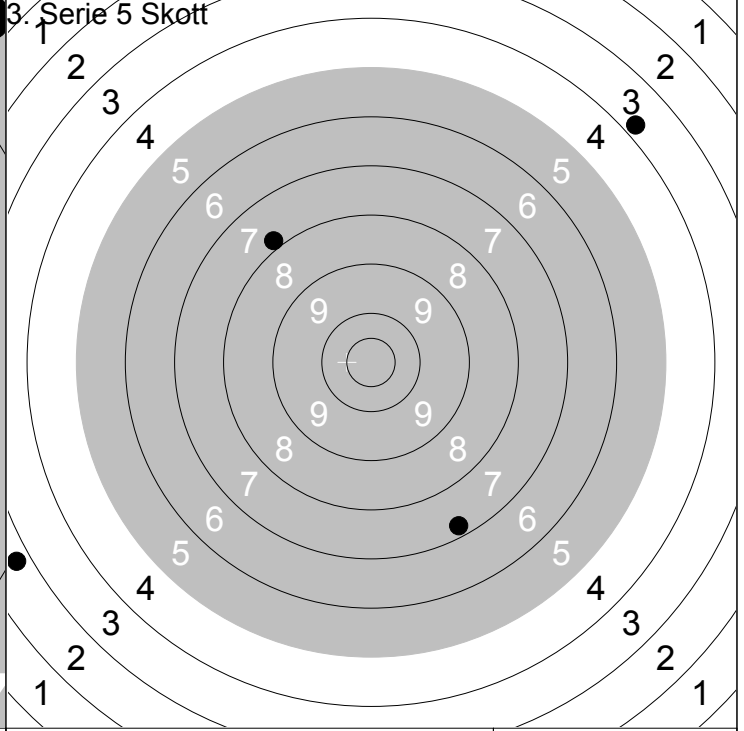
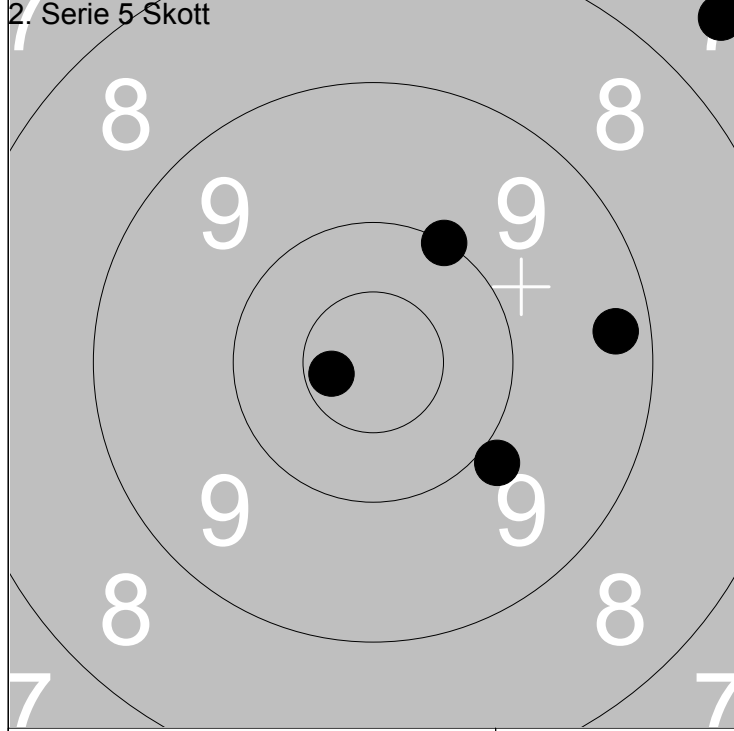

1:	10.0	↗
2:	10.7x	←
3:	9.9	↘
4:	9.3	→
5:	7.5	↗

Serie	45
Total	90

1:	7.9	↖
2:	7.3	↘
3:	2.7	←
4:	3.8	↗
5:	0.0	

Serie	19
Total	109

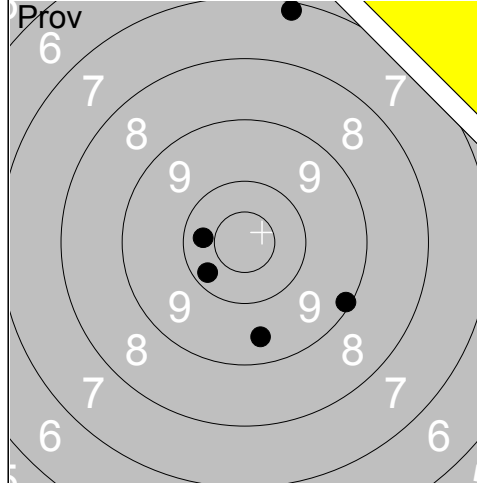

1:	7.2	↑
2:	9.1	→
3:	10.3	←
4:	9.5	↓
5:	10.2	↙
Serie		45
Total		0

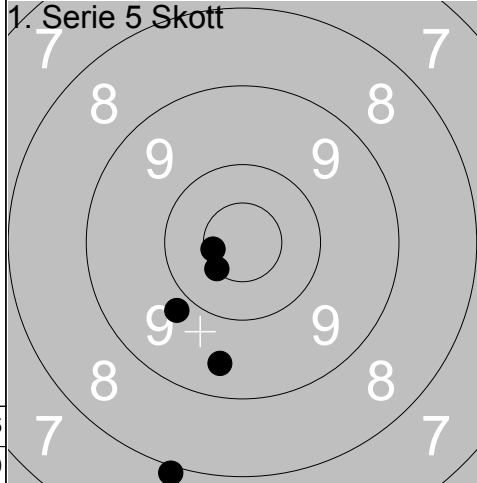

1:	10.5x	↙
2:	7.9	↓
3:	9.5	↓
4:	10.6x	←
5:	9.8	↙
Serie		45
Total		45

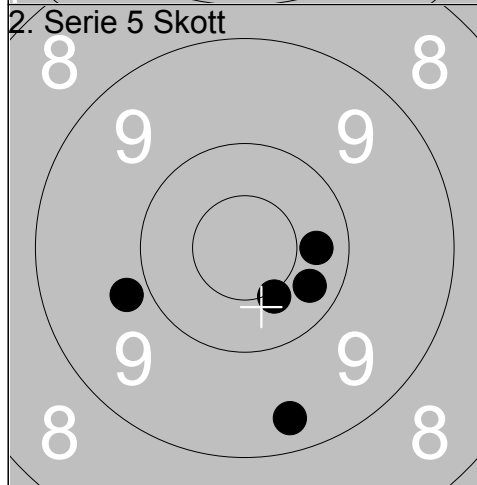

1:	9.3	↓
2:	9.8	←
3:	10.3	→
4:	10.3	→
5:	10.4x	↘
Serie		48
Total		93

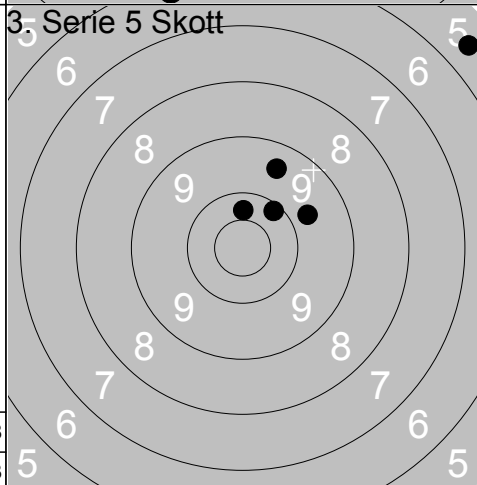

1:	9.5	↑
2:	10.1	↗
3:	9.7	→
4:	10.3	↑
5:	5.6	↗
Serie		43
Total		136

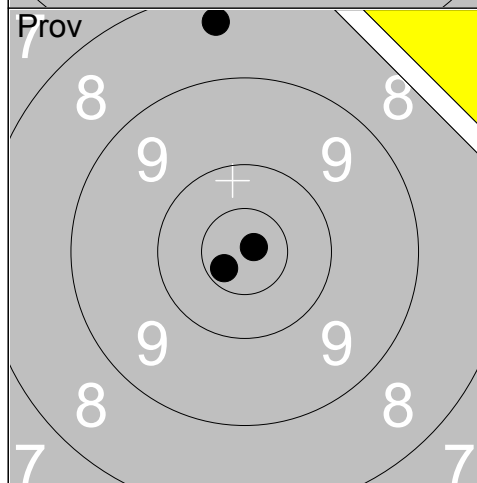

1:	8.4	↑
2:	10.7x	↙
3:	10.8x	↗
Serie		28
Total		136

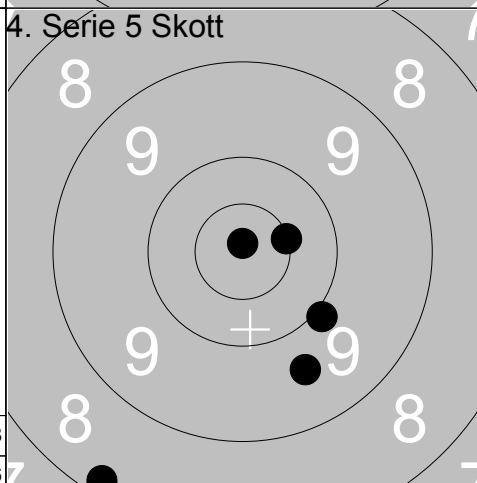

1:	9.9	↘
2:	10.9x	↑
3:	10.5x	→
4:	9.6	↓
5:	8.2	↙
Serie		46
Total		182

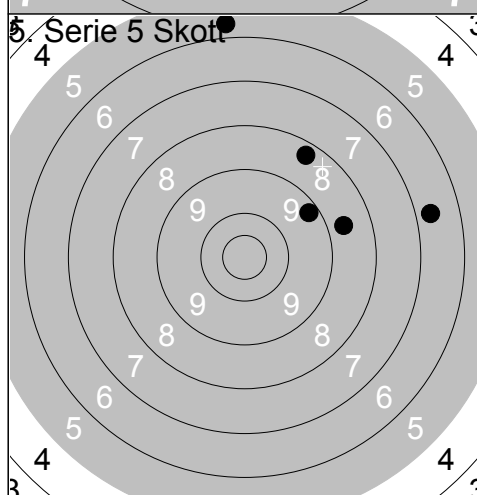

1:	6.7	→
2:	8.7	→
3:	9.3	↗
4:	5.7	↑
5:	8.3	↗
Serie		36
Total		218



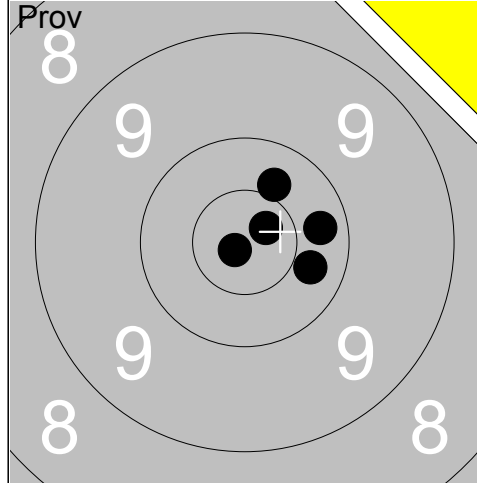

1:	10.3	→
2:	10.7x	↗
3:	10.4	↗
4:	10.8x	↖
5:	10.3	→
Serie		50
Total		0

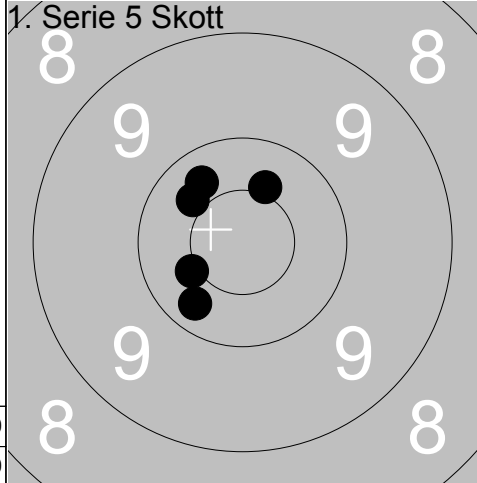

1:	10.3	↖
2:	10.4x	↖
3:	10.4	↗
4:	10.4x	↗
5:	10.3	↖
Serie		50
Total		50

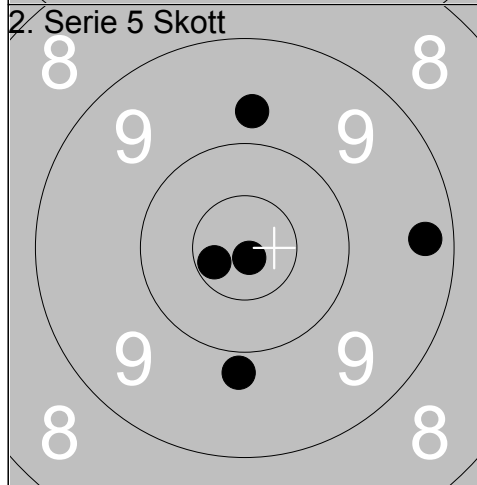

1:	9.3	→
2:	9.7	↑
3:	9.8	↓
4:	10.9x	↓
5:	10.7x	↖
Serie		47
Total		97

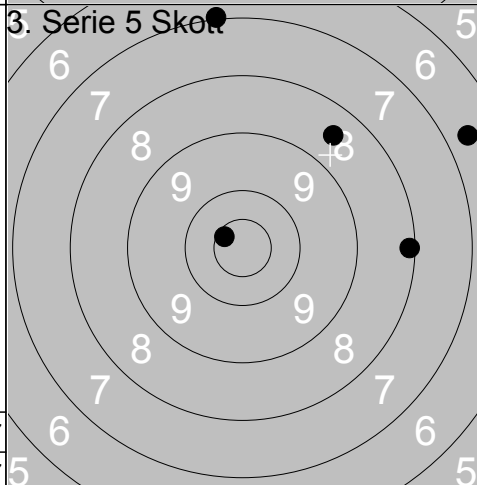

1:	7.0	↑
2:	10.6x	↖
3:	8.1	→
4:	8.5	↗
5:	6.6	↗
Serie		39
Total		136

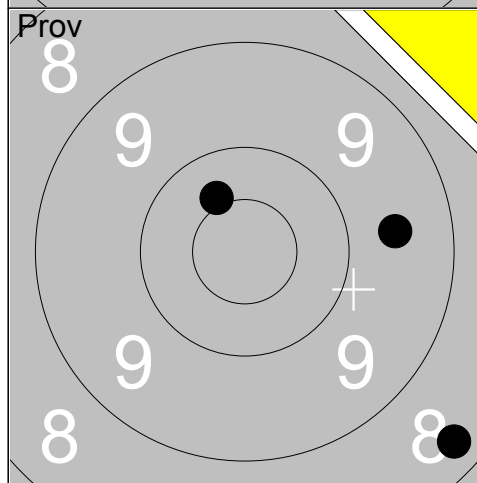

1:	8.3	↘
2:	9.6	→
3:	10.4x	↗
Serie		27
Total		136

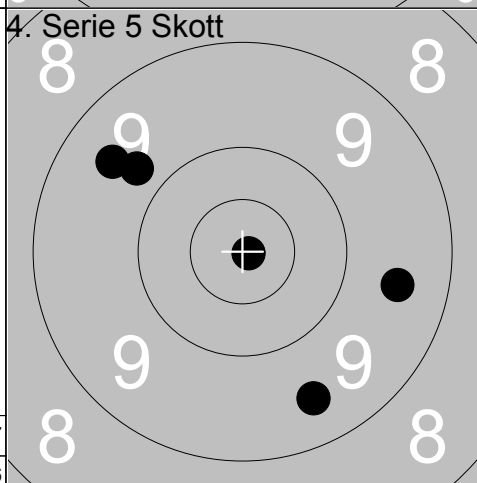

1:	9.5	→
2:	9.5	↘
3:	10.9x	↘
4:	9.7	↗
5:	9.5	↗
Serie		46
Total		182

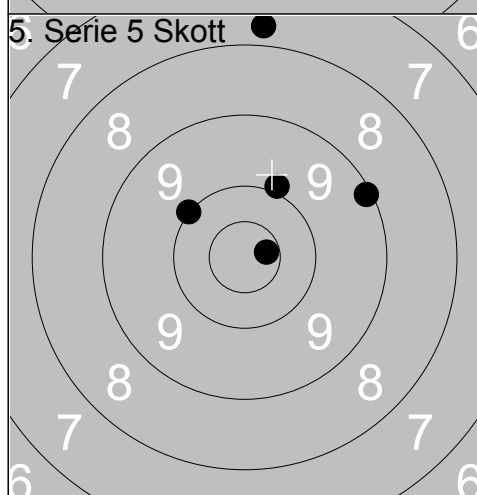

1:	10.0	↖
2:	9.1	↗
3:	10.7x	→
4:	9.9	↗
5:	7.8	↑
Serie		45
Total		227

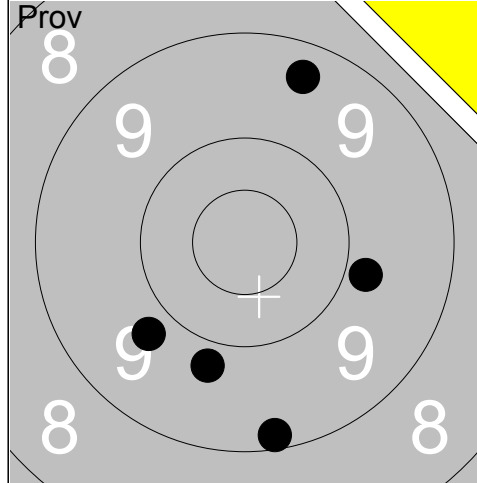

1:	9.8	↙
2:	9.2	↓
3:	9.8	↓
4:	9.4	↗
5:	9.8	→
Serie		45
Total		0

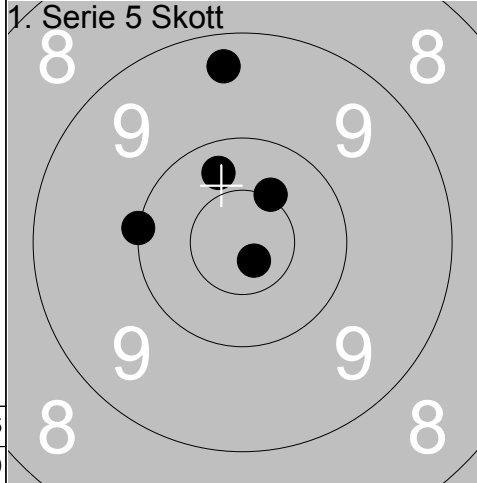

1:	10.0	←
2:	10.3	↗
3:	9.3	↗
4:	10.8x	↓
5:	10.5x	↗
Serie		49
Total		49

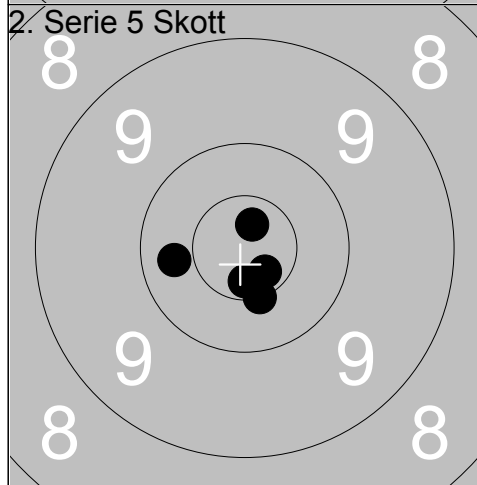

1:	10.3	←
2:	10.7x	↘
3:	10.7x	↓
4:	10.5x	↓
5:	10.7x	↗
Serie		50
Total		99

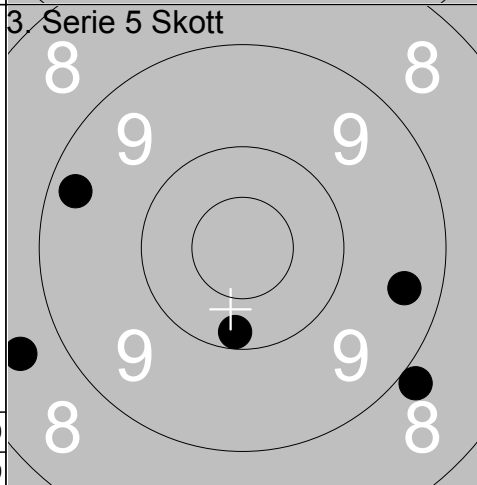

1:	9.4	→
2:	10.2	↓
3:	8.9	↘
4:	8.6	←
5:	9.3	←
Serie		44
Total		143

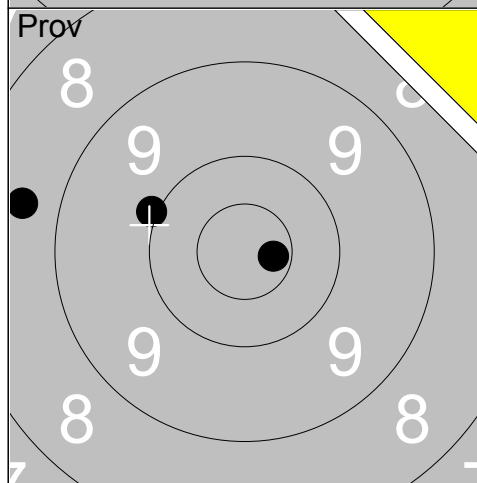

1:	8.6	←
2:	10.7x	→
3:	10.0	↗
Serie		28
Total		143

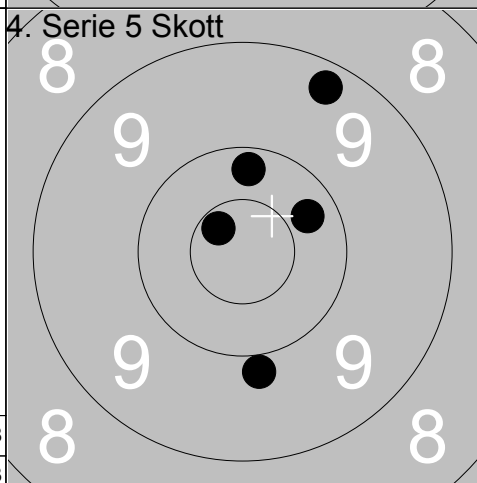

1:	10.7x	↖
2:	10.2	↑
3:	9.3	↗
4:	10.3	↗
5:	9.9	↓
Serie		48
Total		191

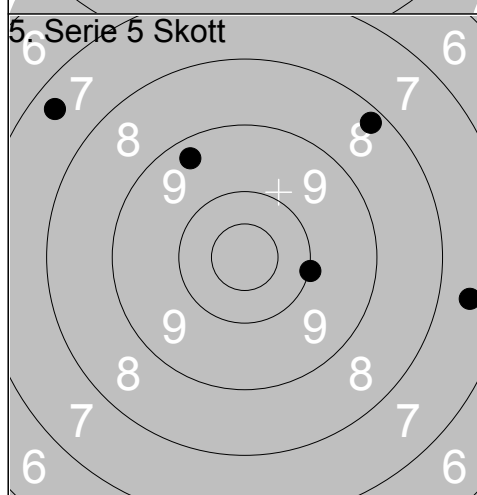

1:	9.3	↗
2:	7.6	→
3:	10.0	→
4:	8.2	↗
5:	7.4	↗
Serie		41
Total		232

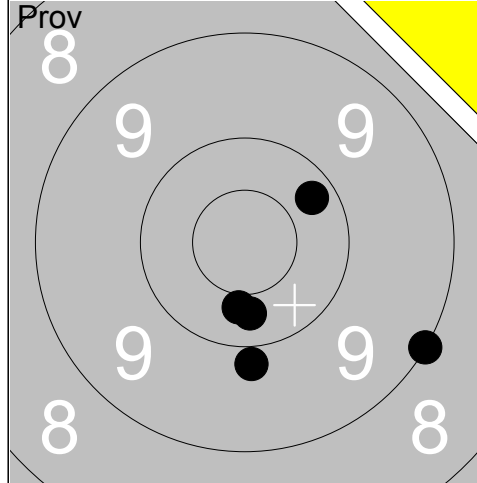

1:	9.9	↓
2:	10.4	↓
3:	10.3	↓
4:	10.2	↗
5:	9.0	↘
Serie		48
Total		0

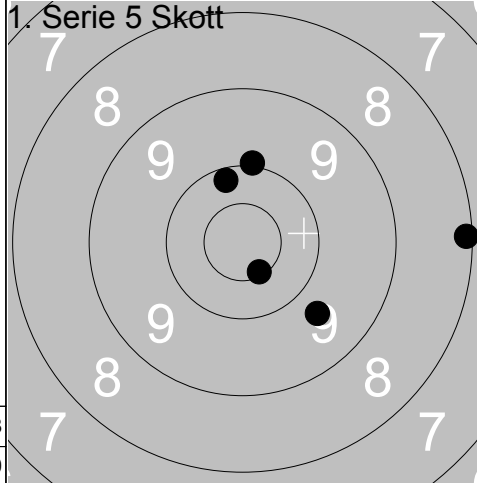

1:	10.2	↑
2:	9.7	↘
3:	10.0	↑
4:	10.5x	↘
5:	8.1	→
Serie		47
Total		47

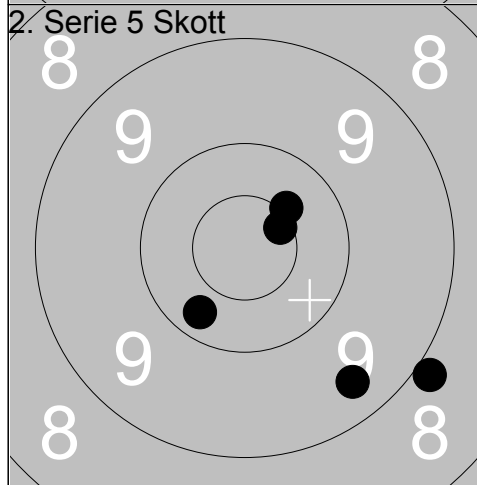

1:	9.4	↘
2:	10.4x	↗
3:	10.3	↘
4:	8.9	↘
5:	10.6x	↗
Serie		47
Total		94

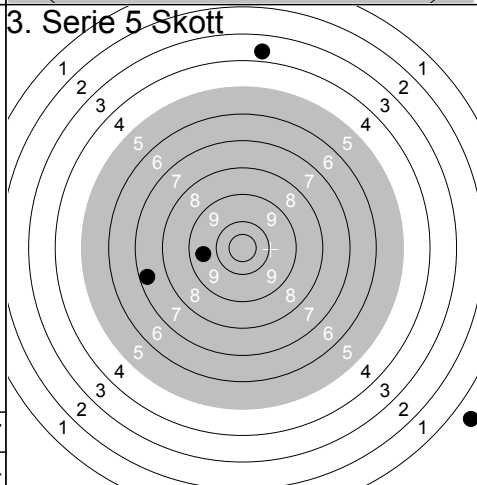

1:	7.3	←
2:	9.5	←
3:	0.0	↘
4:	3.7	↑
5:	0.0	
Serie		19
Total		113

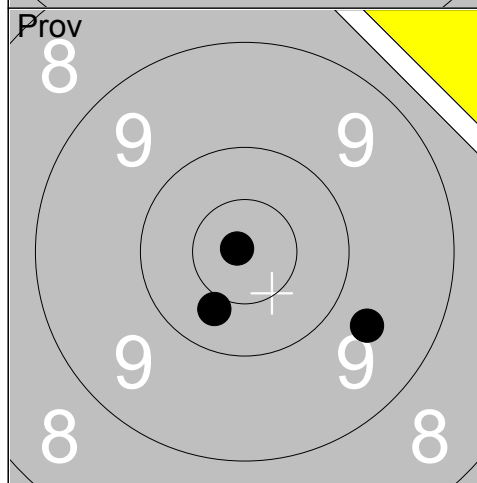

1:	9.7	↘
2:	10.9x	←
3:	10.4	↘
Serie		29
Total		113

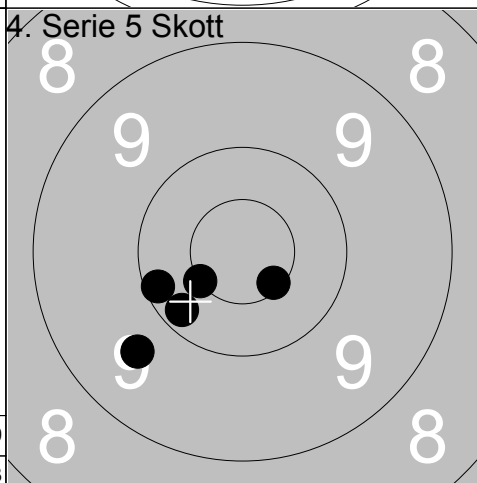

1:	10.5x	←
2:	10.2	↘
3:	9.6	↘
4:	10.6x	↘
5:	10.1	←
Serie		49
Total		162



1:	6.0	↘
2:	10.3	↘
3:	6.5	←
4:	7.0	↑
5:	6.9	→
Serie		35
Total		197

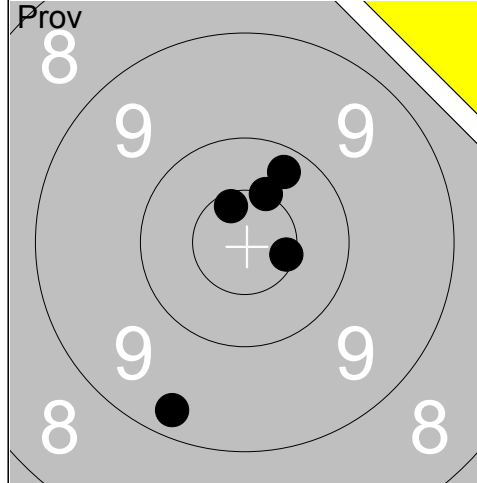

1:	9.3	↘
2:	10.5x	↗
3:	10.6x	↗
4:	10.6x	→
5:	10.2	↗
Serie		49
Total		0

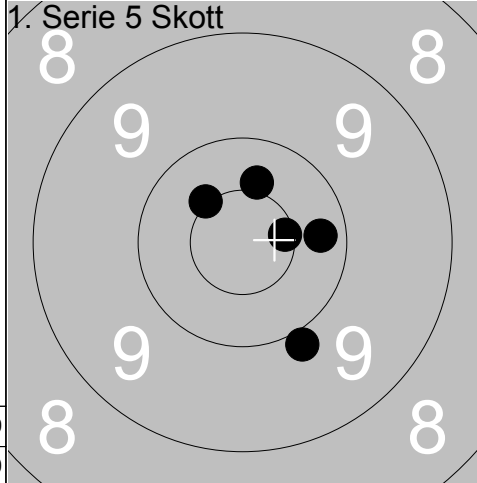

1:	10.4	↗
2:	10.3	→
3:	9.9	↘
4:	10.6x	→
5:	10.5x	↗
Serie		49
Total		49

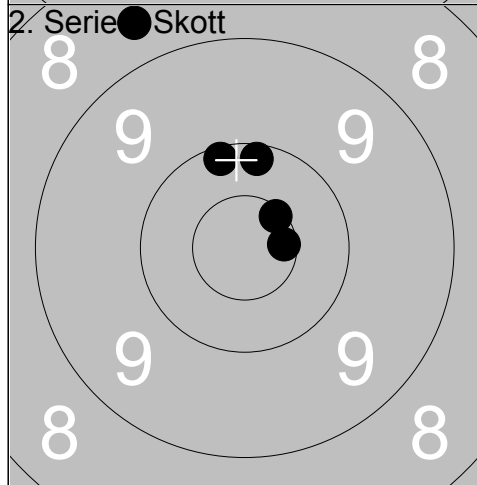

1:	10.6x	↗
2:	10.1	↗
3:	8.6	↗
4:	10.6x	→
5:	10.2	↗
Serie		48
Total		97

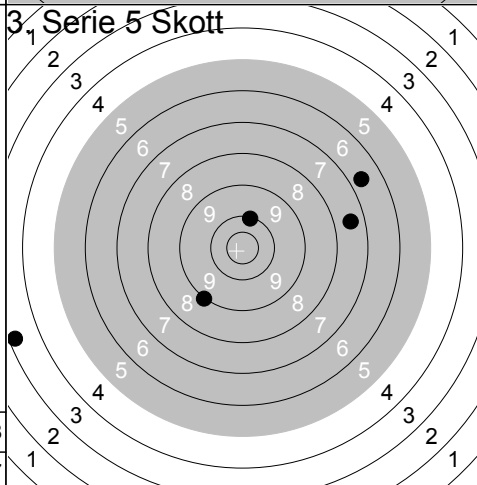

1:	7.5	→
2:	10.1	↗
3:	6.7	↗
4:	9.0	↘
5:	3.2	←
Serie		35
Total		132

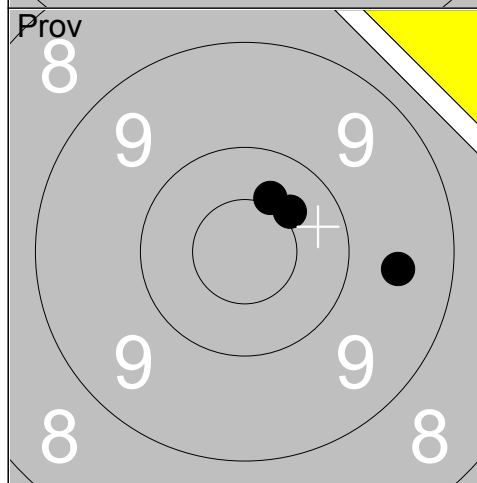

1:	10.4x	↗
2:	10.4x	↗
3:	9.6	→
Serie		29
Total		132

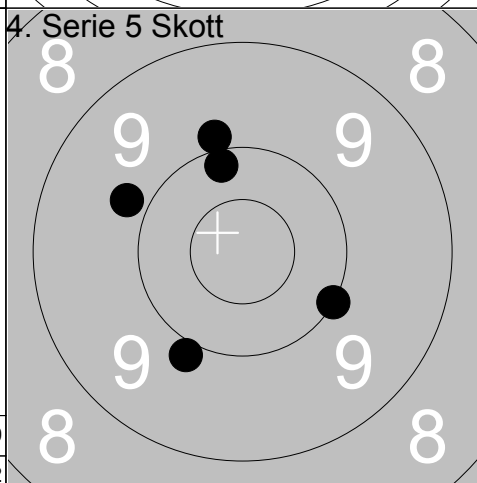

1:	10.2	↗
2:	10.0	→
3:	9.9	↗
4:	9.8	↖
5:	9.9	↘
Serie		47
Total		179

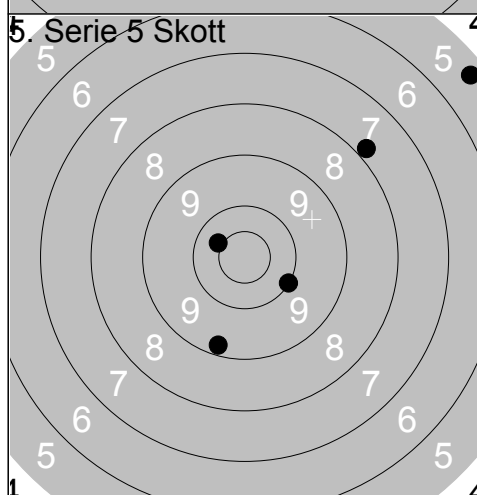

1:	10.4	↖
2:	9.2	↘
3:	10.0	→
4:	7.8	↗
5:	5.3	↗
Serie		41
Total		220

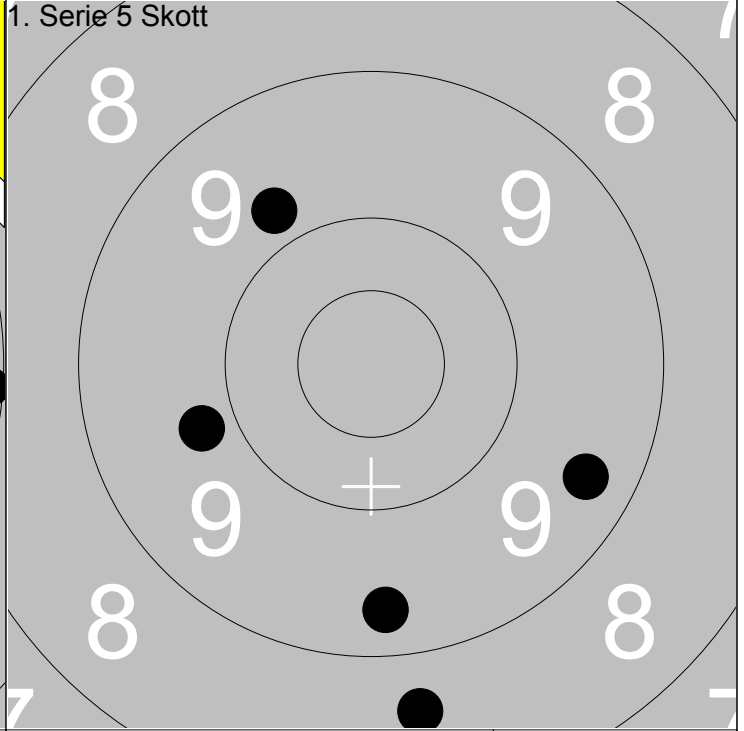
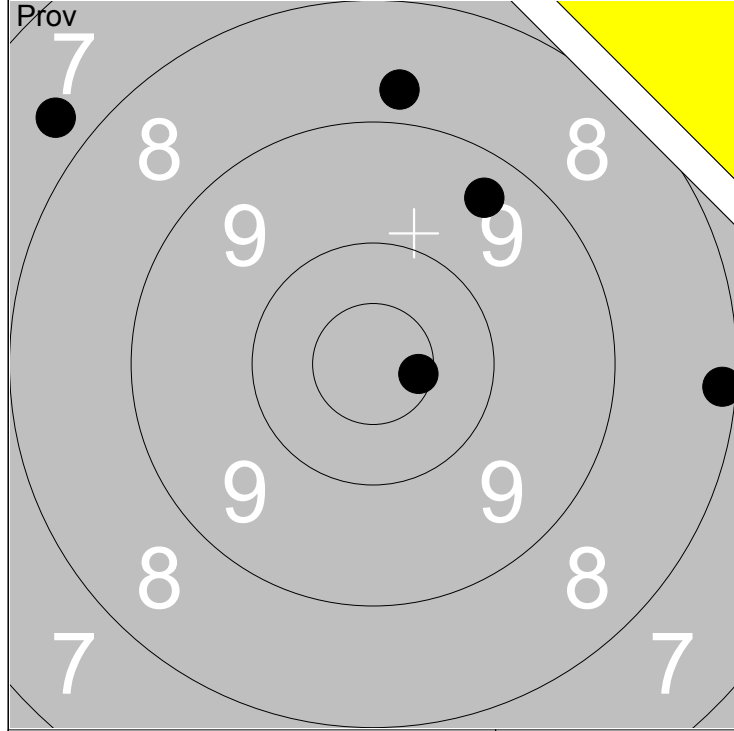

1:	7.7	↖
2:	8.1	→
3:	10.6x	→
4:	9.4	↗
5:	8.8	↑

Serie	42
Total	0

1:	8.6	↓
2:	9.8	←
3:	9.8	↖
4:	9.4	↗
5:	9.3	↓

Serie	44
Total	44

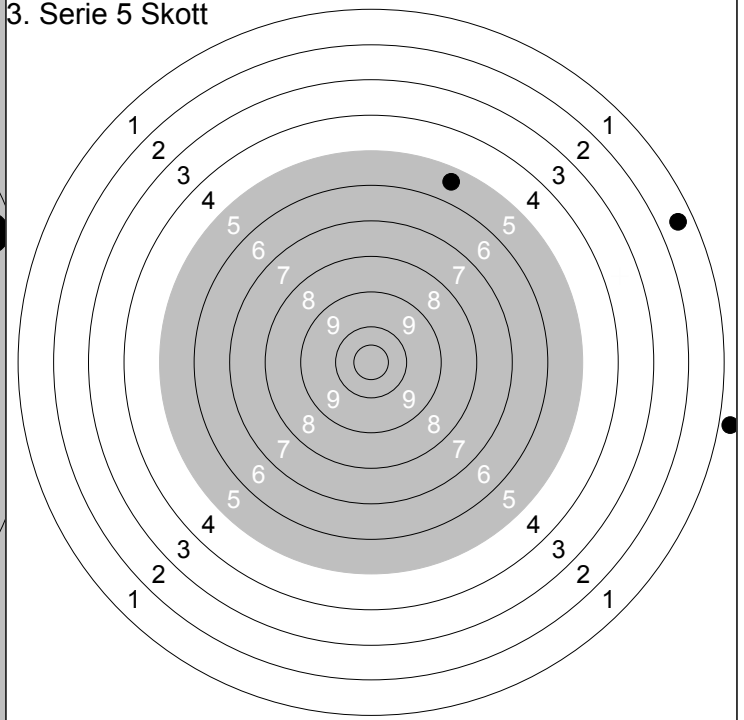
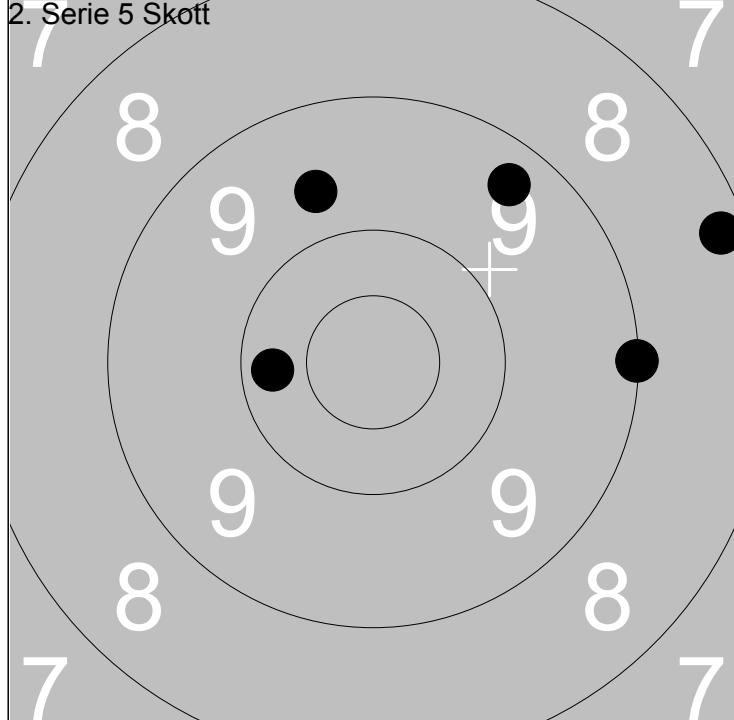

1:	9.3	↗
2:	8.2	→
3:	9.7	↖
4:	10.2	←
5:	9.0	→

Serie	45
Total	89

1:	1.5	↗
2:	5.4	↖
3:	0.0	→
4:	0.0	
5:	0.0	

Serie	6
Total	95