

1: 10.6x →	6: 10.3x ←	Serie	96
2: 10.1 →	7: 8.7 ↓		
3: 9.3 ↗	8: 10.5x →	Total	196
4: 10.5x →	9: 10.3x ↓		
5: 10.0 →	10: 9.6 ↓		

1: 8.8 ↑	Serie	47
2: 10.0 ↙		
3: 10.5x ↘	Total	243
4: 9.5 ↗		
5: 10.3x ↙		

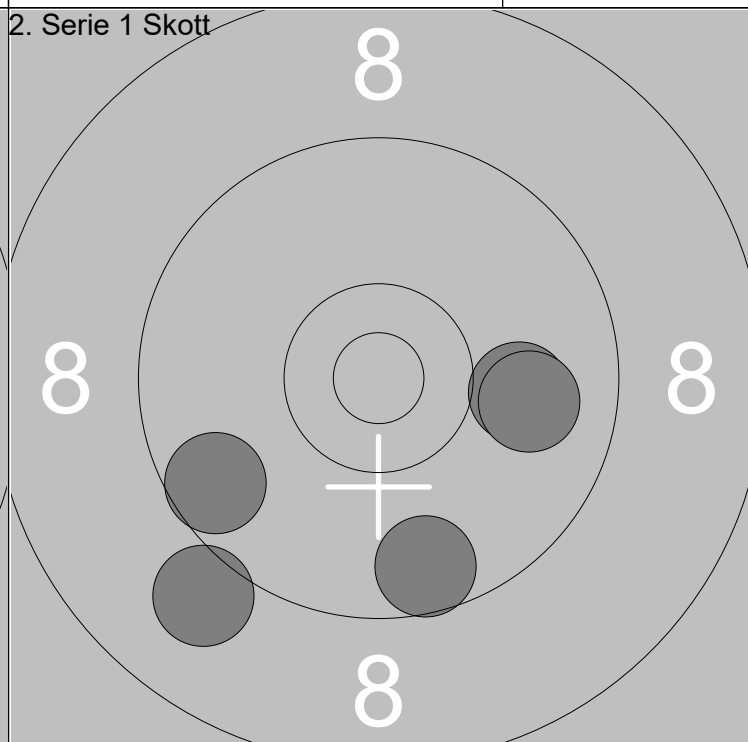
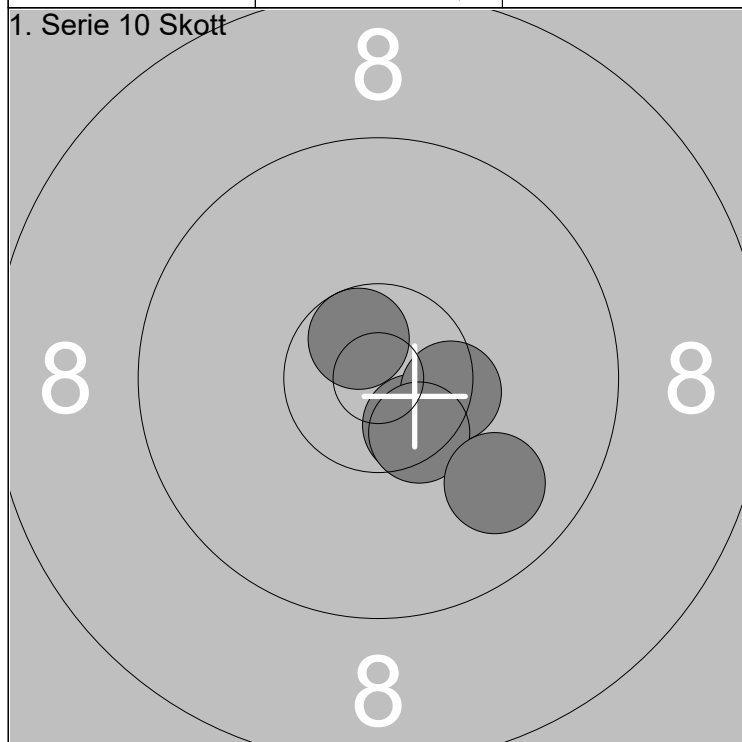

6: 10.5x ↓	Serie	49
7: 10.4x →		
8: 10.5x ↓	Total	292
9: 10.6x ↗		
10: 9.9 ↓		

1: 9.6 ↙	Serie	46
2: 10.0 →		
3: 9.6 ↓	Total	338
4: 9.9 →		
5: 9.0 ↙		

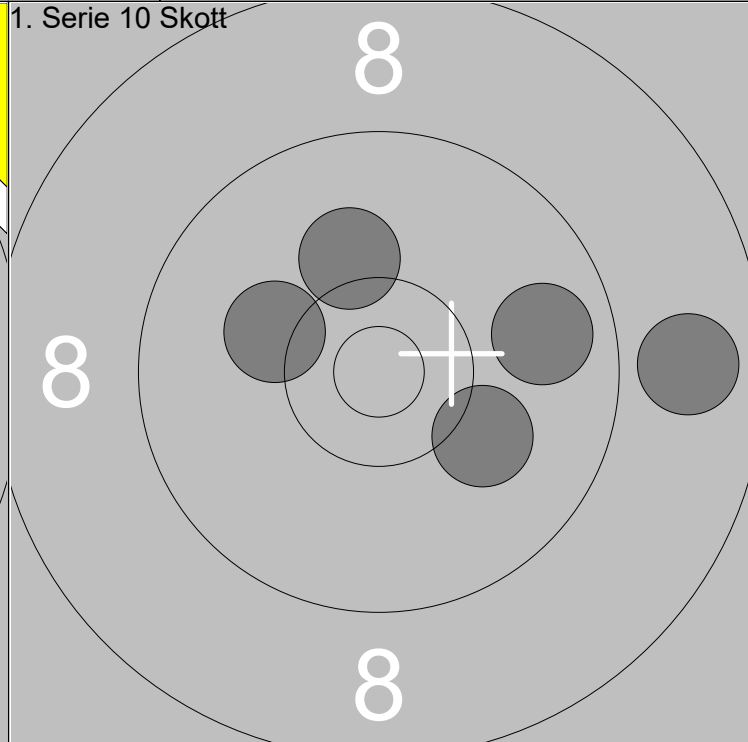
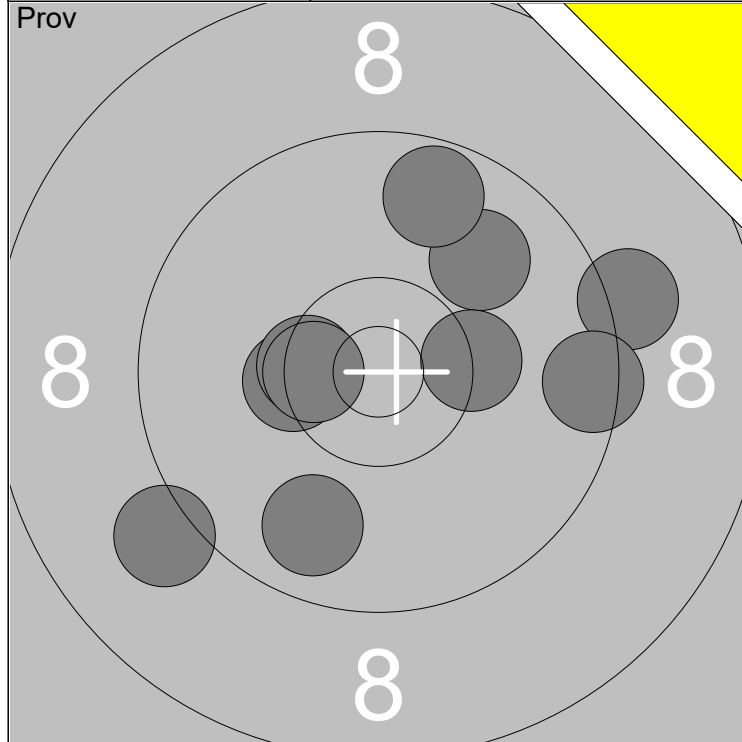

1: 9.1 ↙	6: 10.5x ←	Serie	94
2: 9.8 ↓	7: 9.7 ↑		
3: 10.4x ←	8: 9.5 →	Total	192
4: 9.9 ↗	9: 10.3x →		
5: 9.2 →	10: 10.5x ←		

1: 10.2 ↙	Serie	47
2: 10.1 ↑		
3: 10.1 ↘	Total	239
4: 8.8 →		
5: 9.8 →		

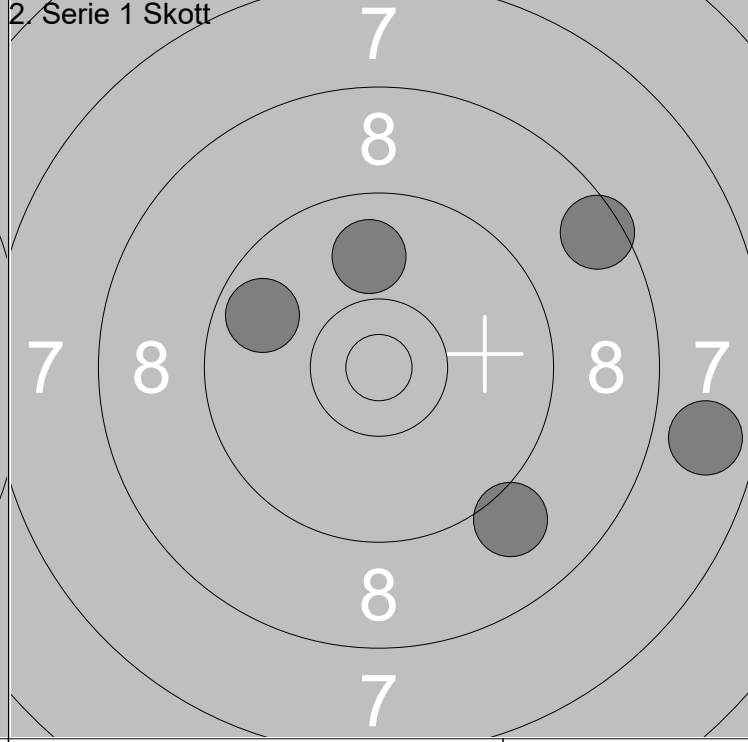
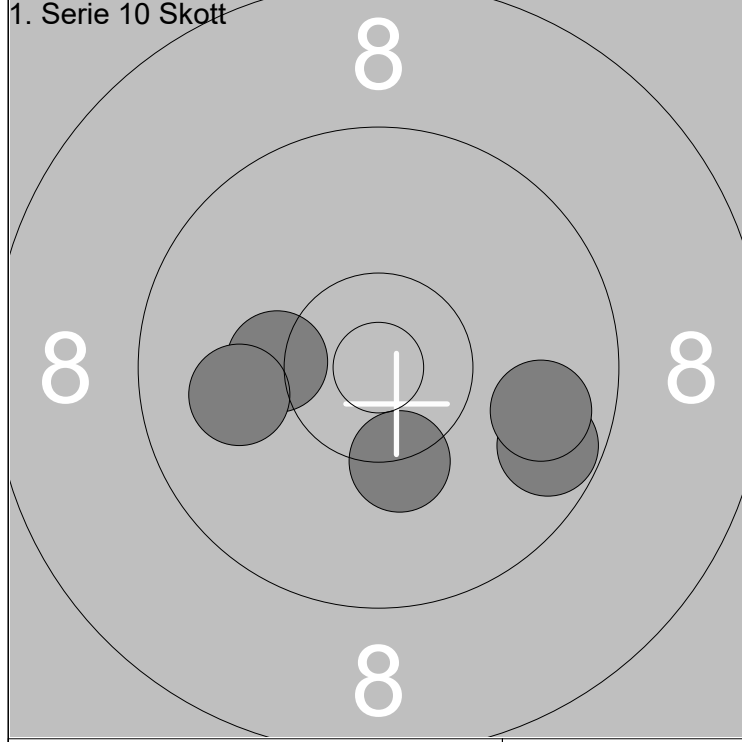

6: 9.7 →	Serie	48
7: 10.3 ←		
8: 9.8 →	Total	287
9: 10.0 ←		
10: 10.3x ↓		

1: 9.0 ↓	Serie	42
2: 7.8 →		
3: 9.7 ↙	Total	329
4: 9.9 ↑		
5: 8.5 ↗		

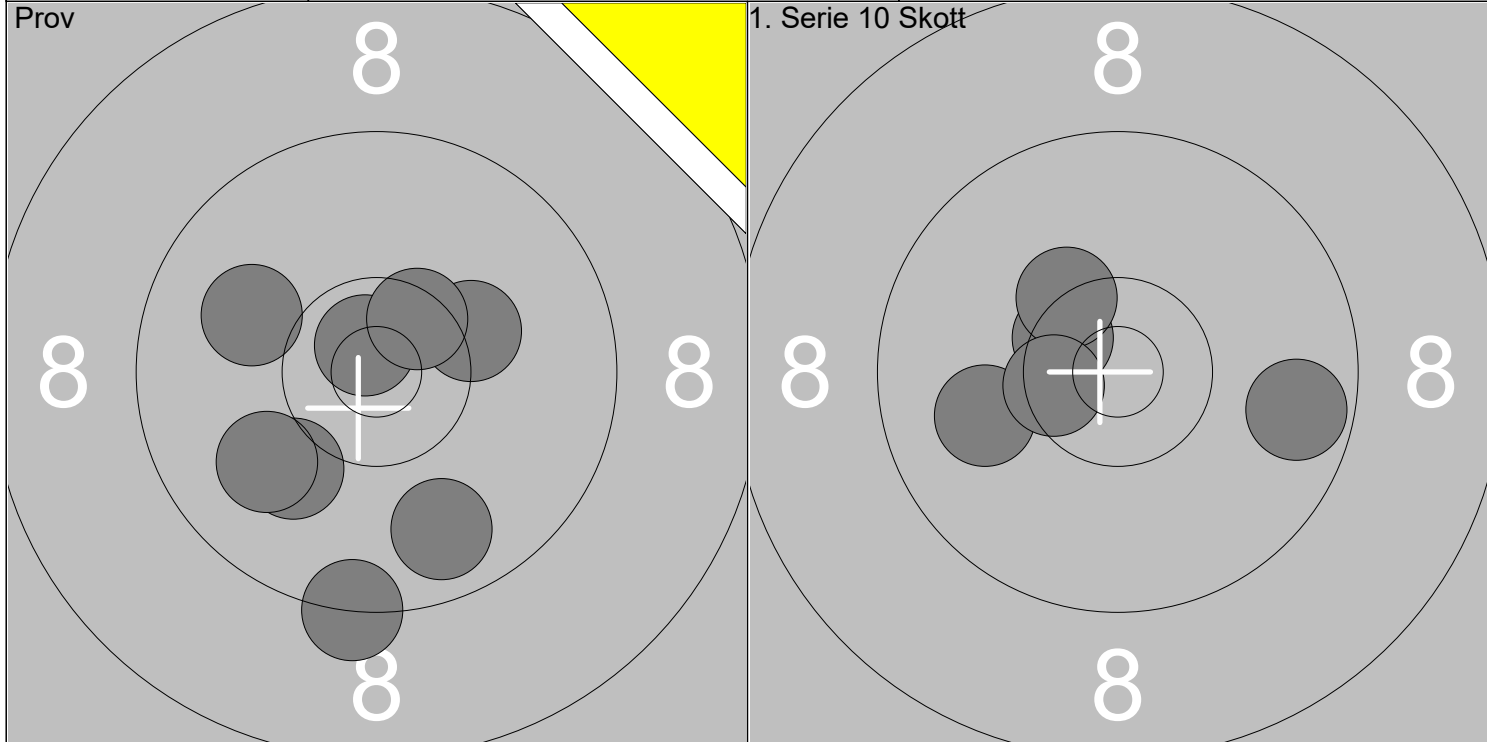

1: 10.8x ↗	6: 9.8 ↓		1: 10.5x ↖		
2: 10.2 →	7: 9.3 ↓	Serie	2: 10.0 ←		Serie
3: 10.1 ↙	8: 10.0 ↙	Total	3: 9.7 →		Total
4: 10.0 ↖		191	4: 10.3x ↗		240
5: 10.5x ↗			5: 10.5x ←		

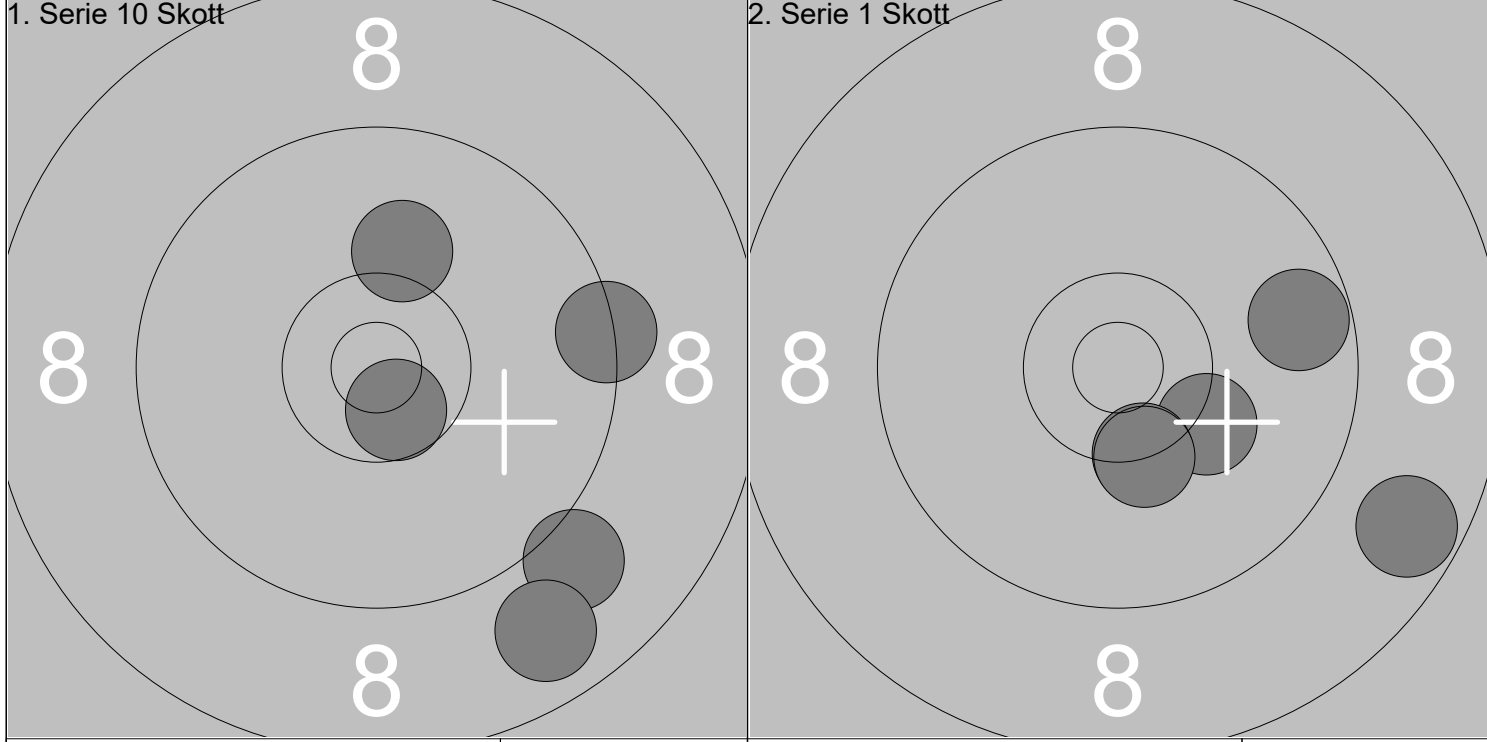

6: 9.1 ↓			1: 9.7 →		
7: 10.1 ↑		Serie	2: 8.7 ↓		Serie
8: 10.6x ↓		Total	3: 10.2 ↓		Total
9: 8.8 ↓		286	4: 10.3x ↓		333
10: 9.4 →			5: 10.3x ↓		

	<p>1: 9.9 ↑</p> <p>2: 10.3 →</p> <p>3: 10.5 ✕</p> <p>4: 10.7 ✕ →</p> <p>5: 10.8 ✕</p> <p>6: 10.8 ✕ →</p> <p>7: 10.5 ✕</p> <p>8: 10.2 ↓</p> <p>9: 10.2 ↑</p> <p>10: 9.5 →</p>		<p>11: 10.0 ↙</p> <p>12: 10.4 ✕</p> <p>13: 10.2 ←</p> <p>14: 9.2 ←</p> <p>15: 8.3 ↓</p>
Serie 98.0		Serie 47.0	
Total 191.0		Total 191.0	

<p>1. Serie 10 Skott</p> 	<p>1: 10.1 →</p> <p>2: 9.2 ↓</p> <p>3: 9.1 ↓</p> <p>4: 9.6 ↑</p> <p>5: 10.6 ✕</p>	<p>1. Serie 10 Skott</p> 	<p>6: 10.5 ✕ ↘</p> <p>7: 10.3 ↓</p> <p>8: 9.3 ↓</p> <p>9: 10.4 ✕ ↗</p> <p>10: 9.6 ←</p>
Serie 47.0		Serie 48.0	
Total 238.0		Total 286.0	

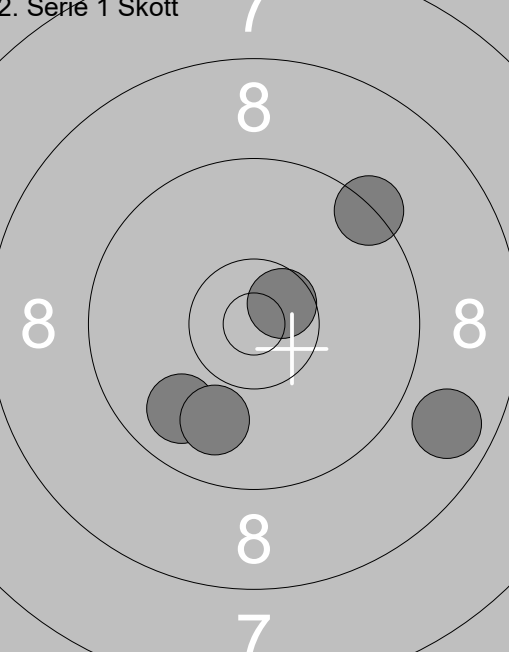
<p>2. Serie 1 Skott</p> 	<p>1: 10.6 ✕ ↗</p> <p>2: 8.8 →</p> <p>3: 9.8 ↙</p> <p>4: 9.9 ↓</p> <p>5: 9.3 ↗</p>		
Serie 45.0			
Total 331.0			

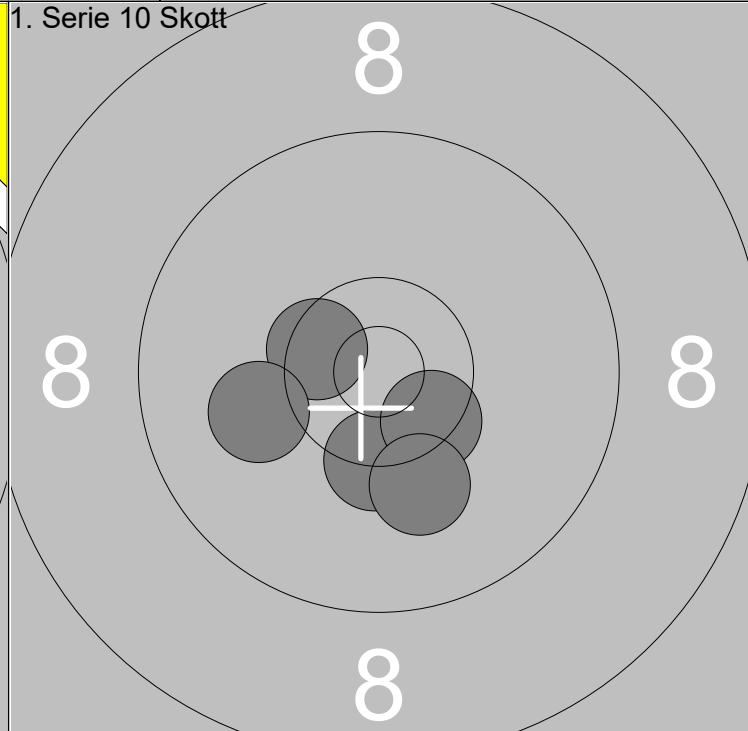
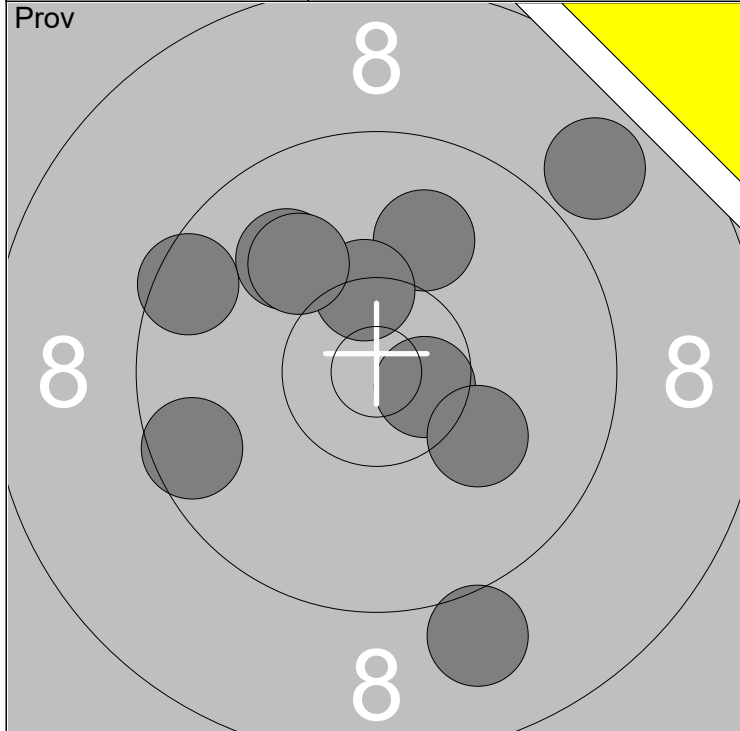

1: 8.9 ↗	6: 9.6 ←		
2: 10.0 ↑	7: 10.6x →		
3: 10.4x ↑	8: 9.5 ↗	Serie	95
4: 10.0 ↗	9: 10.0 ↗	Total	190
5: 9.0 ↓	10: 10.1 ↓		

1: 10.3x ↓		
2: 10.5x ↓		
3: 10.1 ↓	Serie	50
4: 10.5x ←	Total	240
5: 10.1 ←		

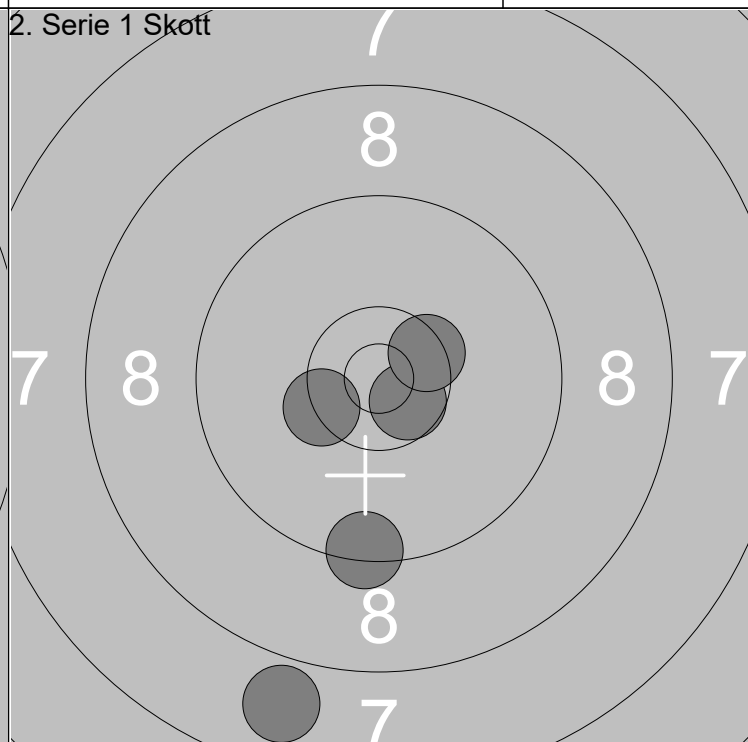
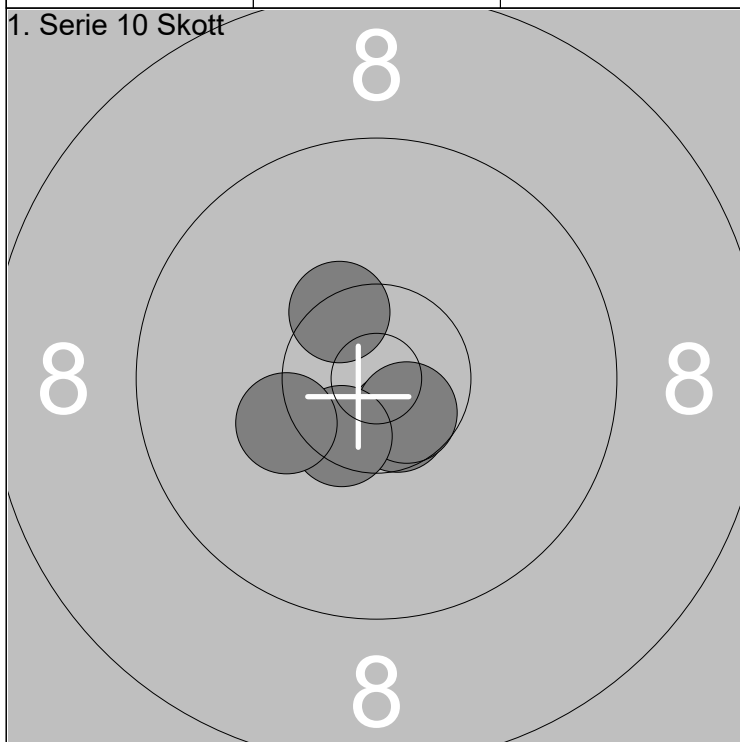

6: 10.6x ↓		
7: 10.4x ↗		
8: 10.6x ↓	Serie	50
9: 10.5x ↓	Total	290
10: 10.3 ←		

1: 9.4 ↓		
2: 10.6x ↓		
3: 10.5x ↗	Serie	46
4: 7.9 ↓	Total	336
5: 10.4x ←		

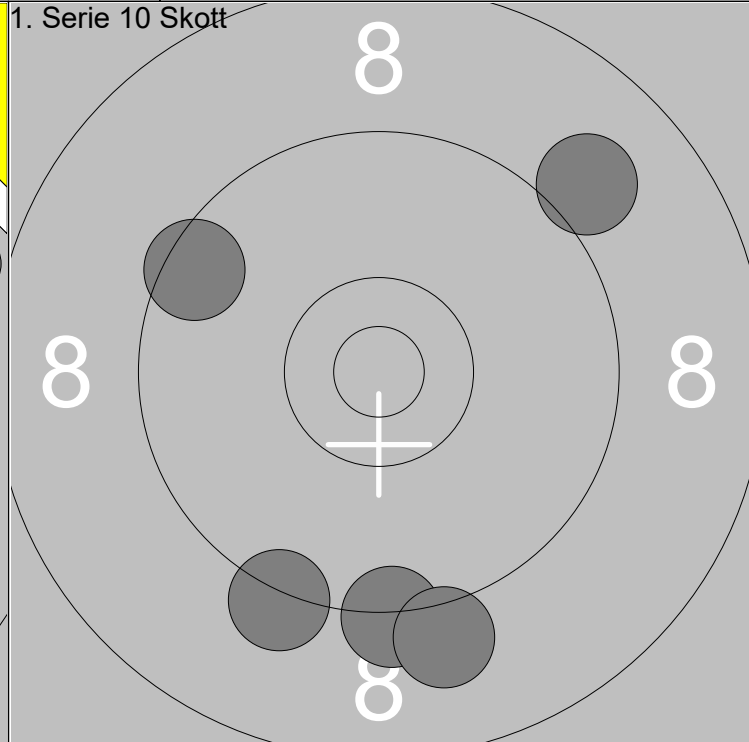
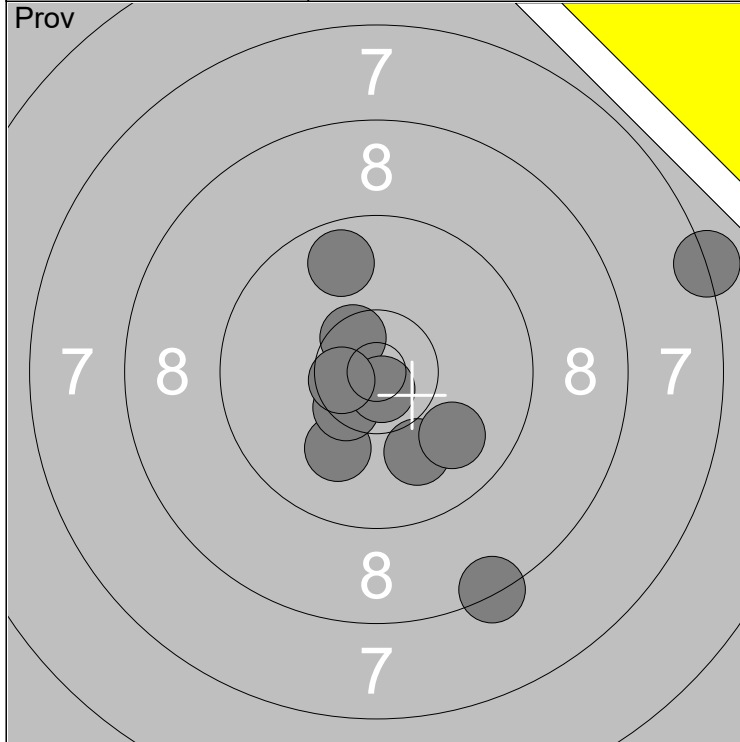

1: 10.1 ↘	6: 7.3 →		
2: 10.0 ↘	7: 9.9 ↘		
3: 10.5x ↙	8: 8.4 ↘	Serie	93
4: 10.5x ↗	9: 9.7 ↗	Total	189
5: 10.8x ↘	10: 10.6x ←		

1: 9.2 ↘			
2: 9.5 ↖			
3: 9.3 ↘	Serie	45	
4: 9.1 ↘	Total	234	
5: 9.0 ↗			

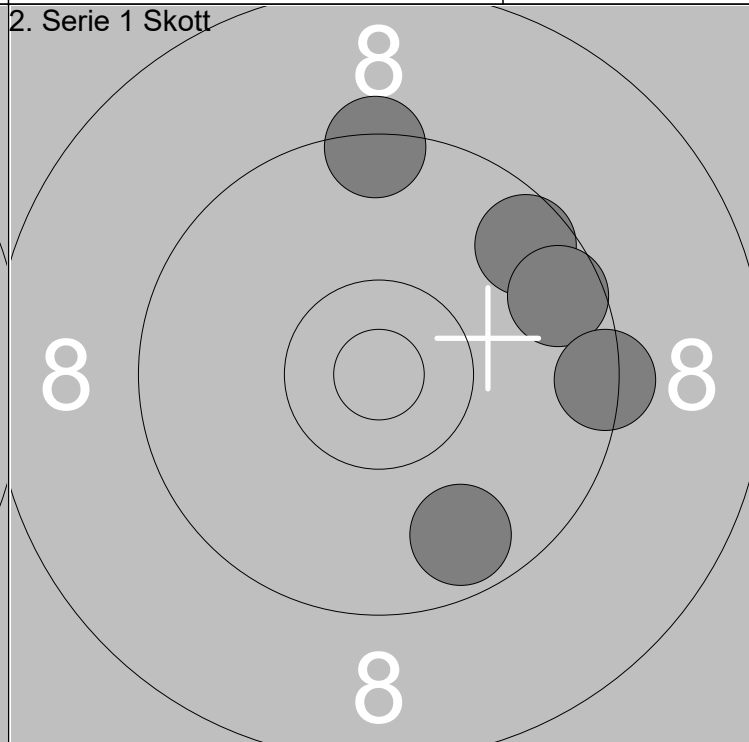
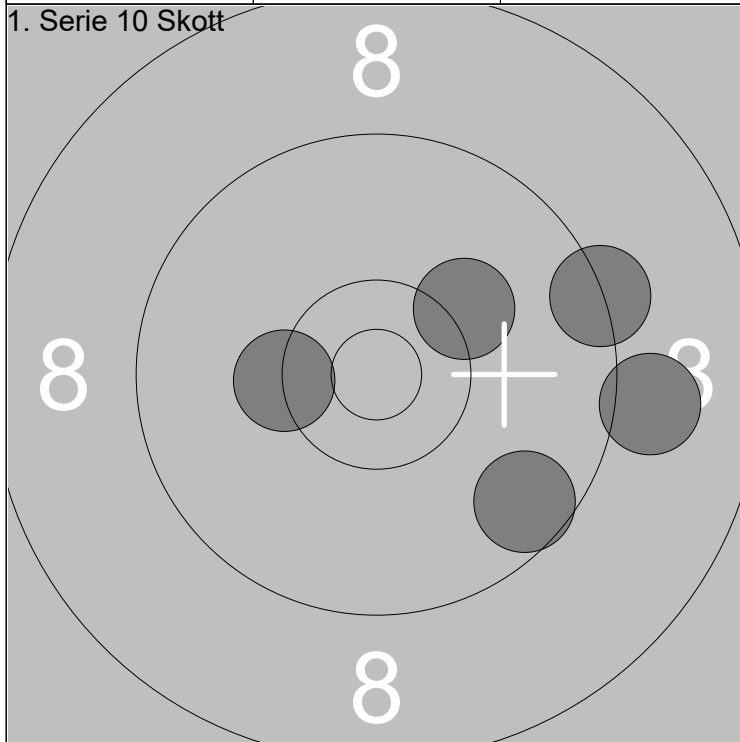

6: 9.3 →			
7: 9.1 →			
8: 10.3x ←	Serie	47	
9: 10.2 ↗	Total	281	
10: 9.6 ↘			

1: 9.4 ↑			
2: 9.6 ↗			
3: 9.7 ↘	Serie	45	
4: 9.6 ↗	Total	326	
5: 9.4 →			

	<p>1: 8.8 ↓</p> <p>2: 8.3 ↓</p> <p>3: 9.3 ↗</p> <p>4: 10.6x↓</p> <p>5: 10.9x↗</p> <p>6: 10.0 ↑</p> <p>7: 9.5 ↓</p> <p>8: 10.7x↓</p> <p>9: 9.8 ↓</p> <p>10: 9.5 ↓</p>		<p>11: 10.0 ↓</p>
Serie 92.0		Serie 10.0	
Total 187.0		Total 187.0	

<p>1. Serie 10 Skott</p>	<p>1: 9.6 ↓</p> <p>2: 9.1 ↑</p> <p>3: 10.0 ↑</p> <p>4: 10.6x↘</p> <p>5: 9.6 →</p>		<p>6: 10.6x↘</p> <p>7: 10.5x↘</p> <p>8: 10.4x↘</p> <p>9: 10.6x↘</p> <p>10: 10.6x↘</p>
Serie 47.0		Serie 50.0	
Total 234.0		Total 284.0	

<p>2. Serie 1 Skott</p>	<p>1: 10.1 ↓</p> <p>2: 10.3x↗</p> <p>3: 10.5x→</p> <p>4: 10.1 ↓</p> <p>5: 10.5x↖</p>		
Serie 50.0			
Total 334.0			

	<p>1: 8.6 ←</p> <p>2: 10.1 ↓</p> <p>3: 10.3x →</p> <p>4: 10.1 ↖</p> <p>5: 9.8 ↗</p> <p>6: 10.4x ←</p> <p>7: 8.8 ←</p> <p>8: 8.8 ↓</p> <p>9: 9.0 ↑</p> <p>10: 9.7 ↙</p>	<p>11: 9.5 ←</p>
8	8	8
7	7	7
Serie 91.0	Serie 9.0	Serie 9.0
Total 187.0	Total 187.0	Total 187.0

<p>1. Serie 10 Skott</p>	<p>1: 9.4 ↖</p> <p>2: 10.5x ←</p> <p>3: 9.7 ↓</p> <p>4: 9.7 ↓</p> <p>5: 10.1 ↖</p>	<p>6: 10.2 ↖</p> <p>7: 9.4 →</p> <p>8: 10.2 ↙</p> <p>9: 9.6 →</p> <p>10: 9.6 →</p>
8	8	8
7	7	7
Serie 47.0	Serie 47.0	Serie 47.0
Total 234.0	Total 234.0	Total 281.0

<p>2. Serie 1 Skott</p>	<p>1: 10.5x ↘</p> <p>2: 10.5x ↘</p> <p>3: 8.9 ↙</p> <p>4: 10.3 ↖</p> <p>5: 9.2 ↓</p>	
8		
7		
Serie 47.0		
Total 328.0		

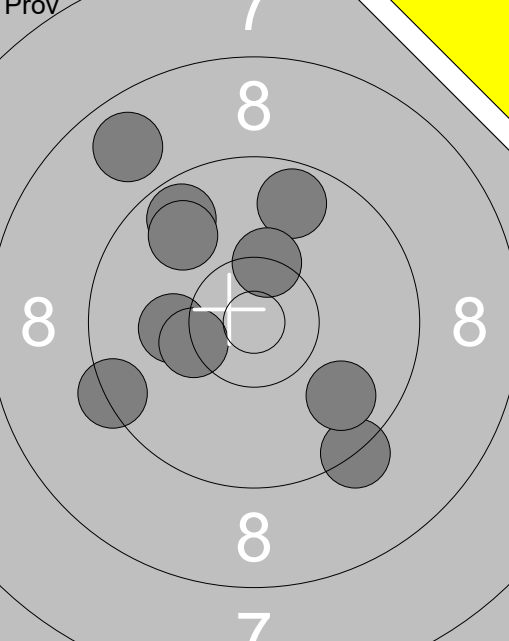
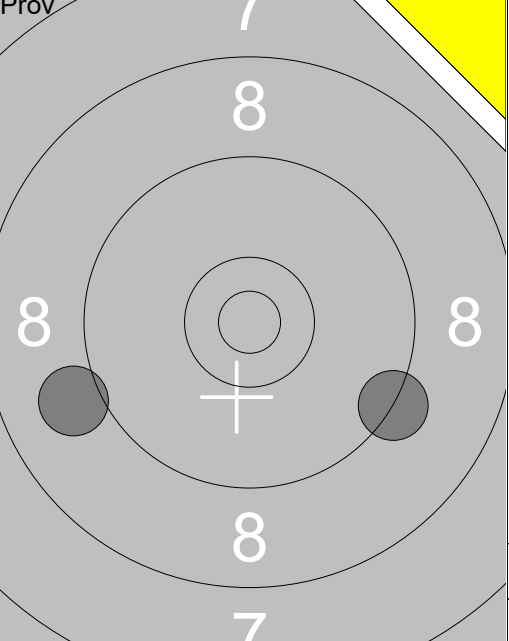
 <p>Prov</p>	<p>1: 9.3 ↘</p> <p>2: 9.8 ↘</p> <p>3: 8.8 ↗</p> <p>4: 9.7 ↗</p> <p>5: 9.8 ↗</p> <p>6: 9.4 ↙</p> <p>7: 10.1 ←</p> <p>8: 10.3 ✕</p> <p>9: 9.7 ↗</p> <p>10: 10.3 ✕ ↗</p>	 <p>Prov</p>	<p>11: 9.3 ↘</p> <p>12: 9.0 ↙</p>
Serie 92.0		Serie 18.0	
Total 187.0		Total 187.0	

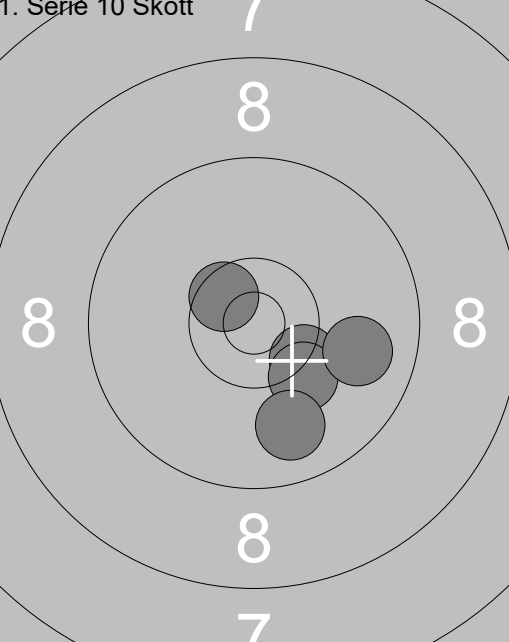
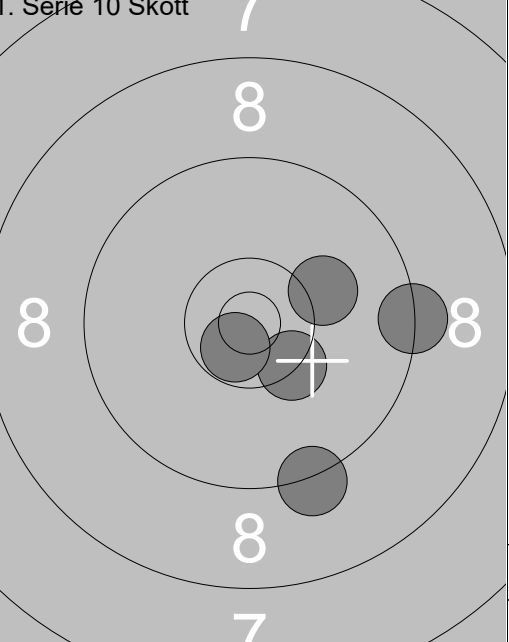
 <p>1. Serie 10 Skott</p>	<p>1: 10.3 ✕ ↘</p> <p>2: 10.2 ↘</p> <p>3: 9.9 →</p> <p>4: 9.9 ↘</p> <p>5: 10.6 ✕ ↘</p>	 <p>1. Serie 10 Skott</p>	<p>6: 10.4 ✕ ↘</p> <p>7: 10.7 ✕ ↘</p> <p>8: 9.3 ↘</p> <p>9: 9.3 →</p> <p>10: 10.2 ↗</p>
Serie 48.0		Serie 48.0	
Total 235.0		Total 283.0	

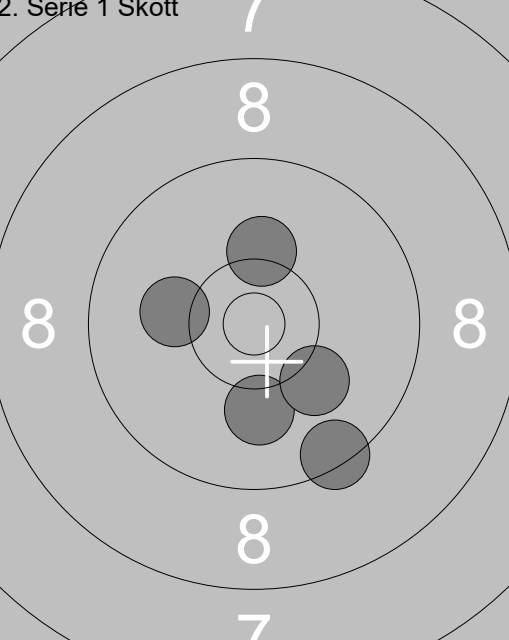
 <p>2. Serie 1 Skott</p>	<p>1: 10.1 ↓</p> <p>2: 10.2 ↑</p> <p>3: 10.1 ↘</p> <p>4: 10.1 ←</p> <p>5: 9.4 ↘</p>		
Serie 49.0			
Total 332.0			

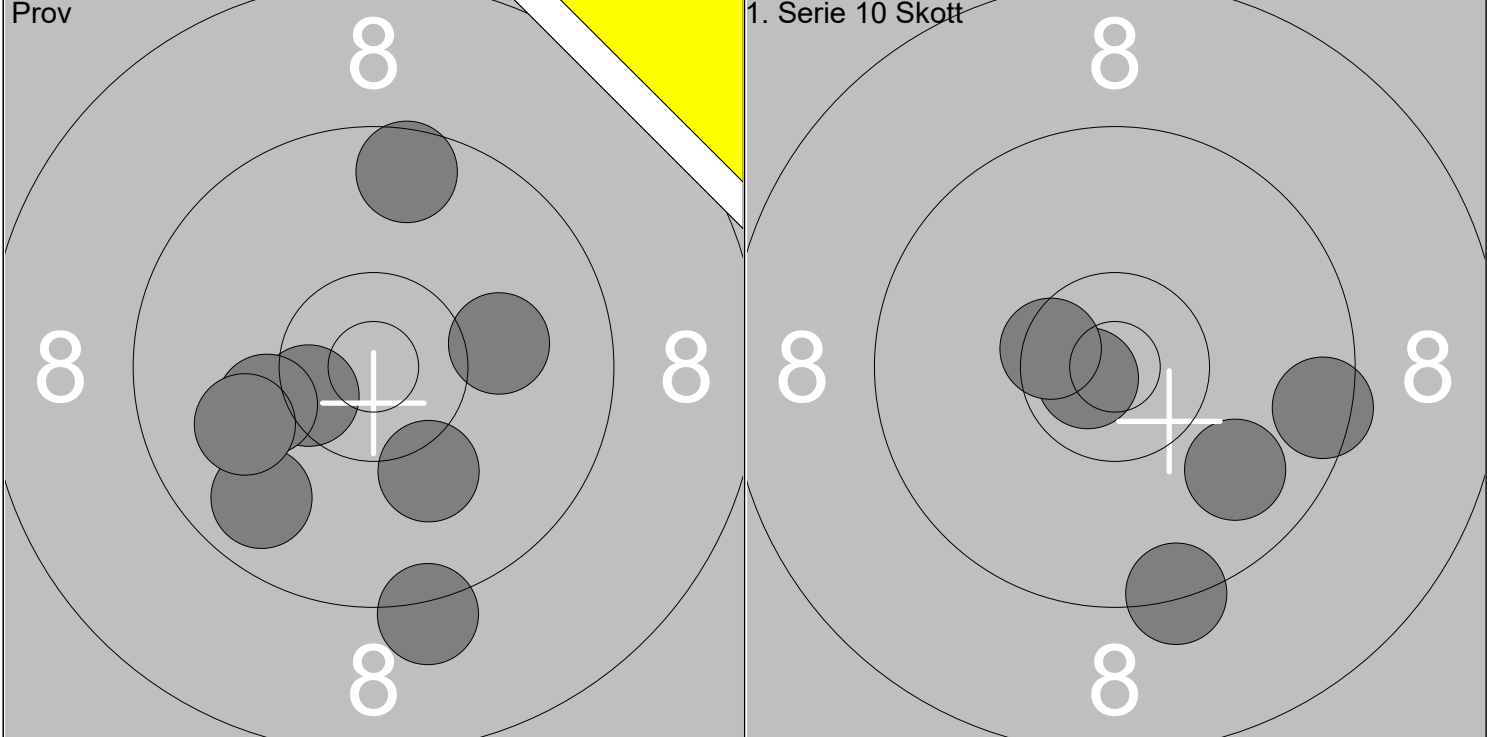

1: 10.1 →	6: 10.2 ←	Serie	77	1: 9.3 ↓	Serie	47
2: 9.8 ↙	7: 10.0 ←			2: 9.9 ↓		
3: 10.5x ←	8: 9.2 ↓	Total	186	3: 10.7x ←	Total	233
4: 9.6 ↑				4: 9.5 →		
5: 10.1 ↓				5: 10.5x ←		

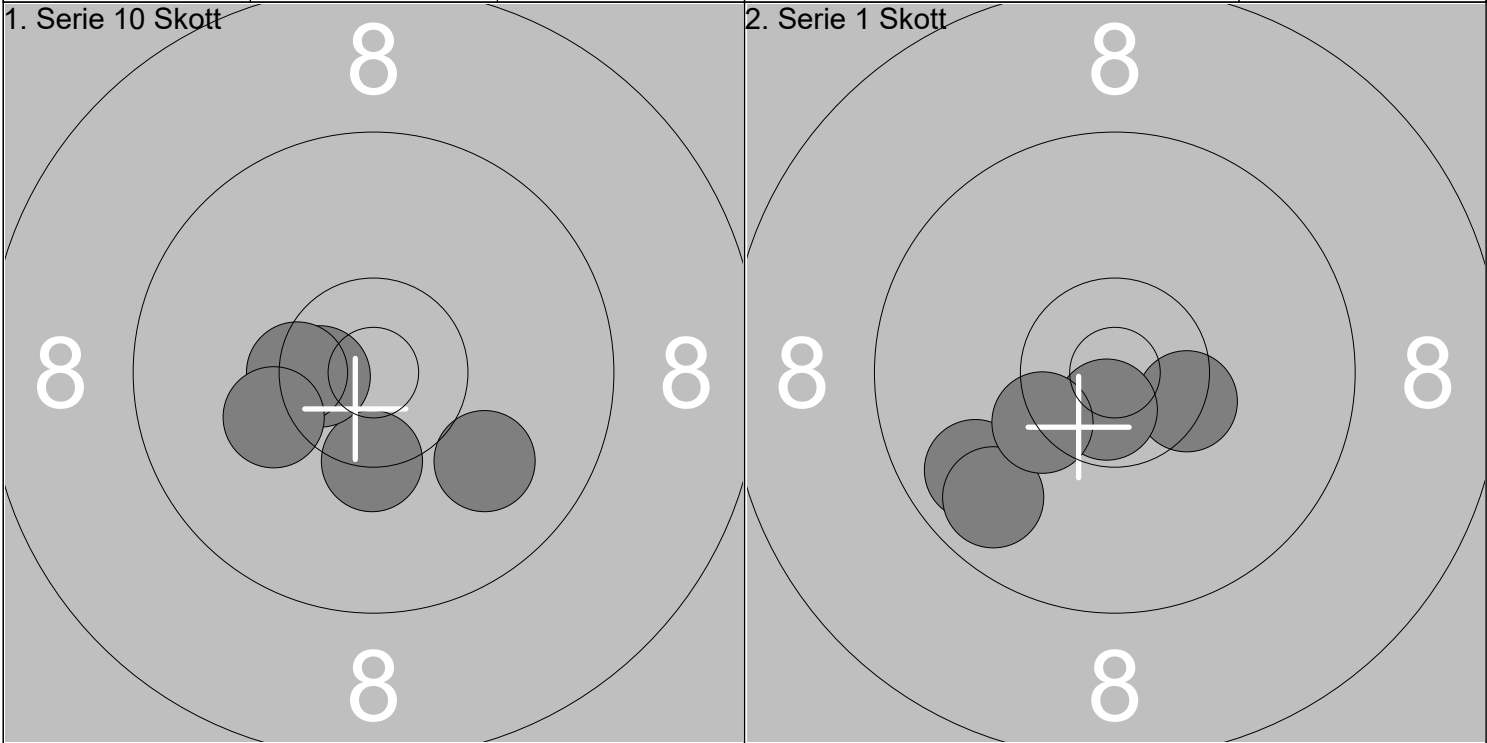

6: 10.0 ↓	Serie	50	1: 10.4x →	Serie	48
7: 10.3x ↓			2: 9.8 ←		
8: 10.6x ←	Total	283	3: 9.8 ←	Total	331
9: 10.4x ←			4: 10.7x ↓		
10: 10.2 ←			5: 10.3x ←		

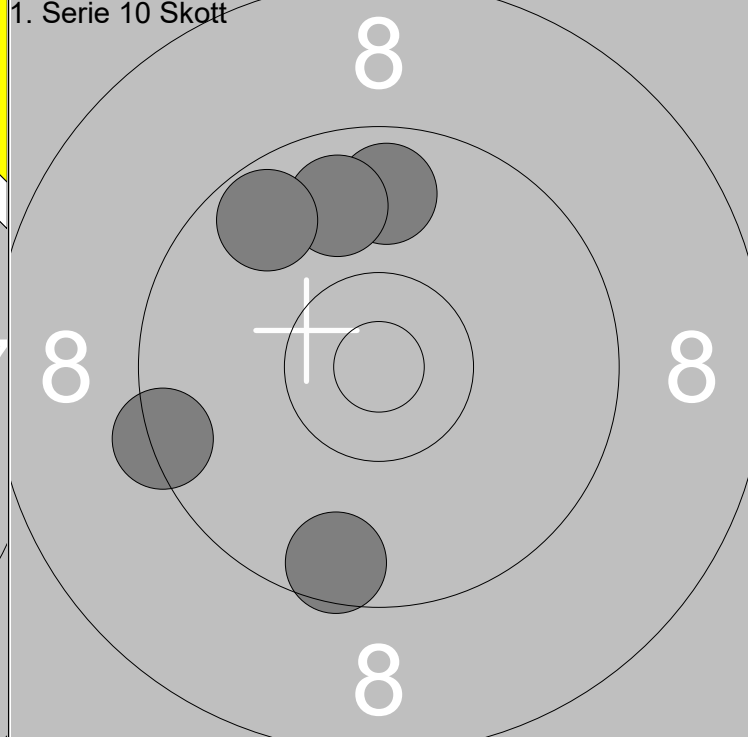
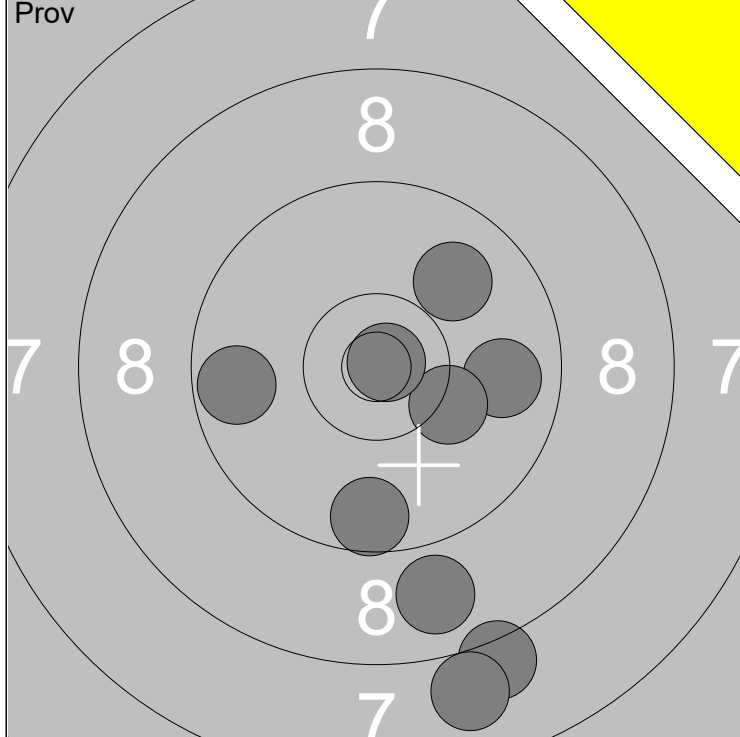

1: 9.9 ↗	6: 7.9 ↓	Serie	79
2: 9.6 ↓	7: 8.9 ↓		
3: 9.7 ←	8: 10.2 →	Total	184
4: 9.8 →	9: 10.9x ↗		
5: 8.1 ↓			

1: 9.8 ↑	Serie	45
2: 9.8 ↑		
3: 9.4 ←	Total	229
4: 9.6 ↓		
5: 9.7 ↖		

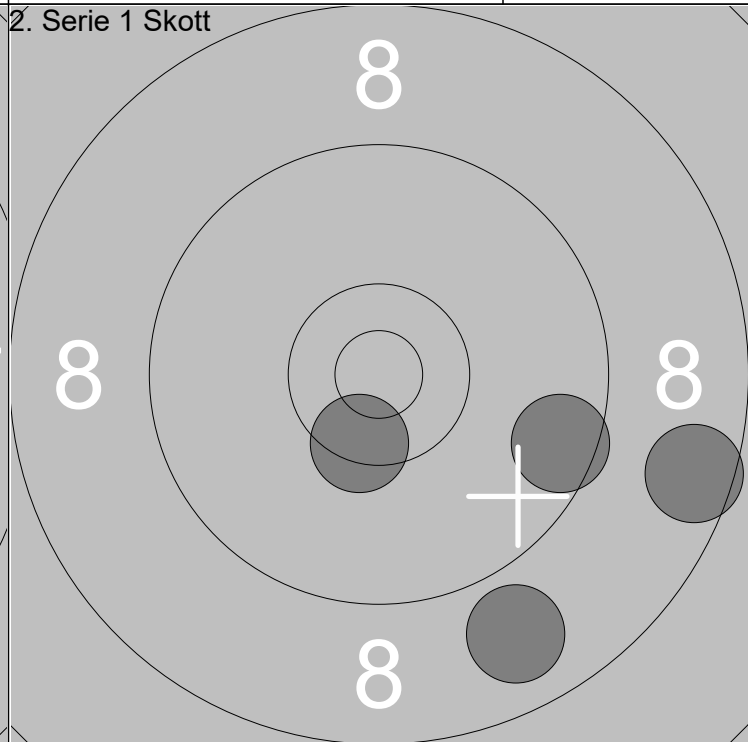
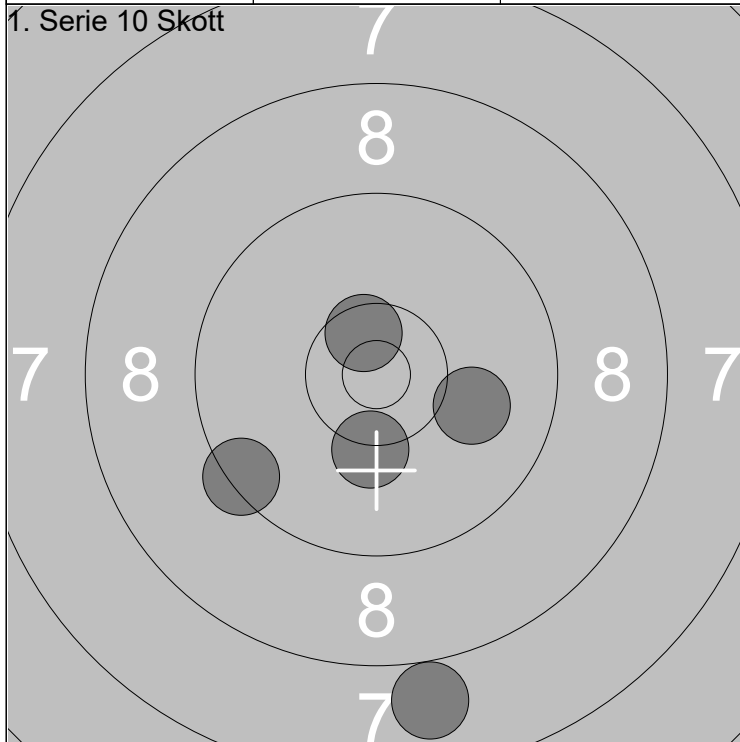

6: 10.6x ↑	Serie	46
7: 7.9 ↓		
8: 10.3 ↓	Total	275
9: 10.0 →		
10: 9.4 ↙		

1: 10.4x ↓	Serie	44
2: 8.6 →		
3: 9.0	Total	319
4: 8.8 ↓		
5: 9.6 →		

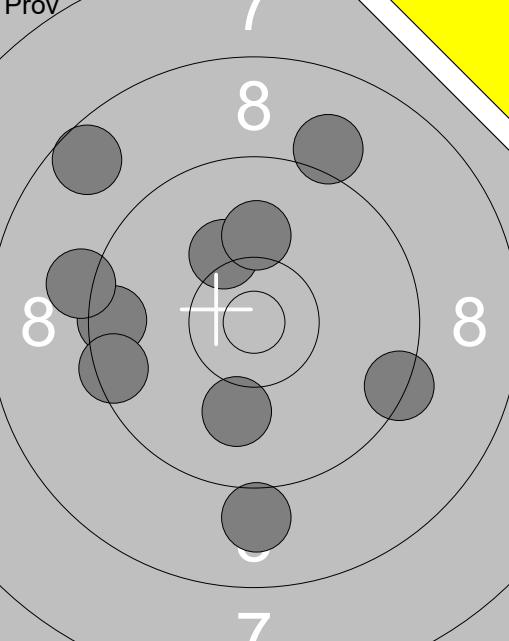
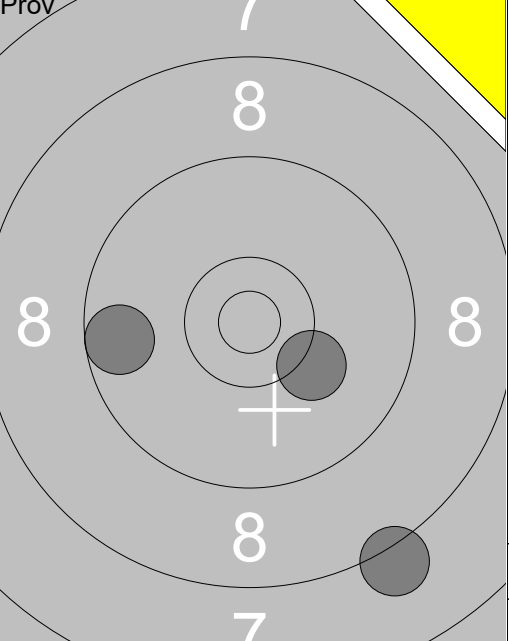
Prov 	1: 9.5 ← 2: 9.2 ← 3: 8.6 ↗ 4: 10.2 ↗ 5: 9.1 ↗ 6: 9.5 ← 7: 10.1 ↗ 8: 9.0 ↓ 9: 9.4 → 10: 10.0 ↓ <hr/> Serie 92.0 <hr/> Total 183.0	Prov 	11: 8.2 ↓ 12: 10.2 ↘ 13: 9.6 ← <hr/> Serie 27.0 <hr/> Total 183.0
------------------------------------------------------------------------------------------	-------------------------------------------------------------------------------------------------------------------------------------------------------------------	--------------------------------------------------------------------------------------------	-------------------------------------------------------------------------------

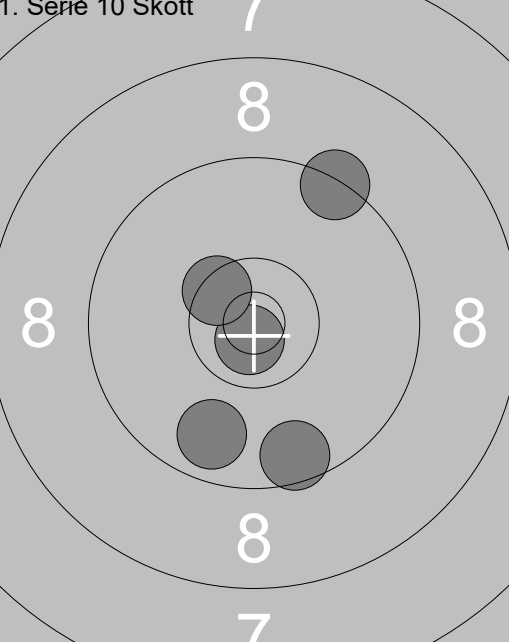
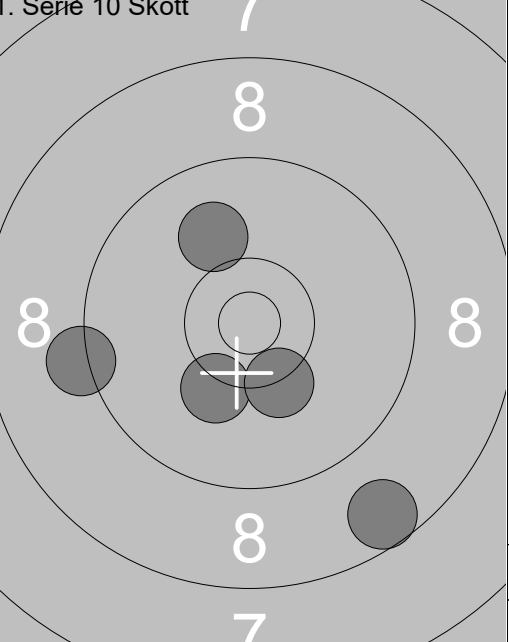
1. Serie 10 Skott 	1: 9.6 ↓ 2: 9.8 ↓ 3: 10.8x ↓ 4: 10.5x ↘ 5: 9.4 ↗ <hr/> Serie 47.0 <hr/> Total 230.0	1. Serie 10 Skott 	6: 10.0 ↗ 7: 10.2 ↓ 8: 8.6 ↓ 9: 10.3 ↓ 10: 9.2 ← <hr/> Serie 47.0 <hr/> Total 277.0
--------------------------------------------------------------------------------------------------------	-------------------------------------------------------------------------------------------------------	----------------------------------------------------------------------------------------------------------	-------------------------------------------------------------------------------------------------------

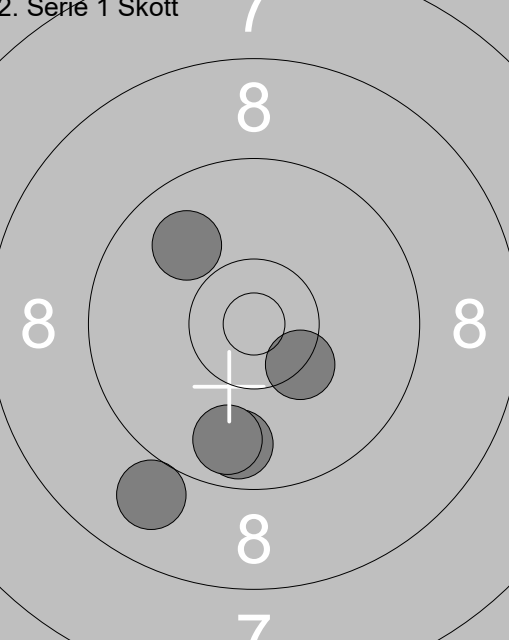
2. Serie 1 Skott 	1: 9.7 ↓ 2: 9.8 ↓ 3: 10.3x ↘ 4: 9.9 ↗ 5: 9.0 ↓ <hr/> Serie 46.0 <hr/> Total 323.0		
--------------------------------------------------------------------------------------------------------	-----------------------------------------------------------------------------------------------------	--	--

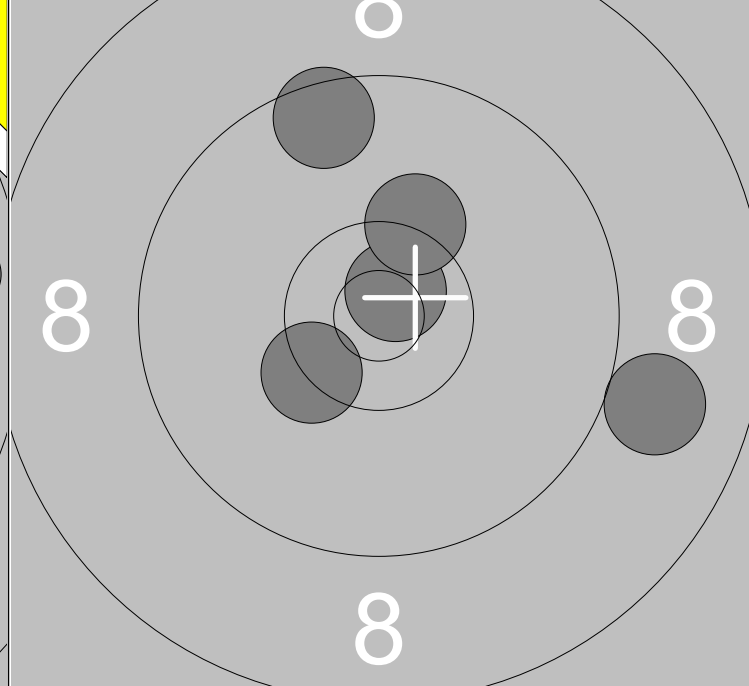
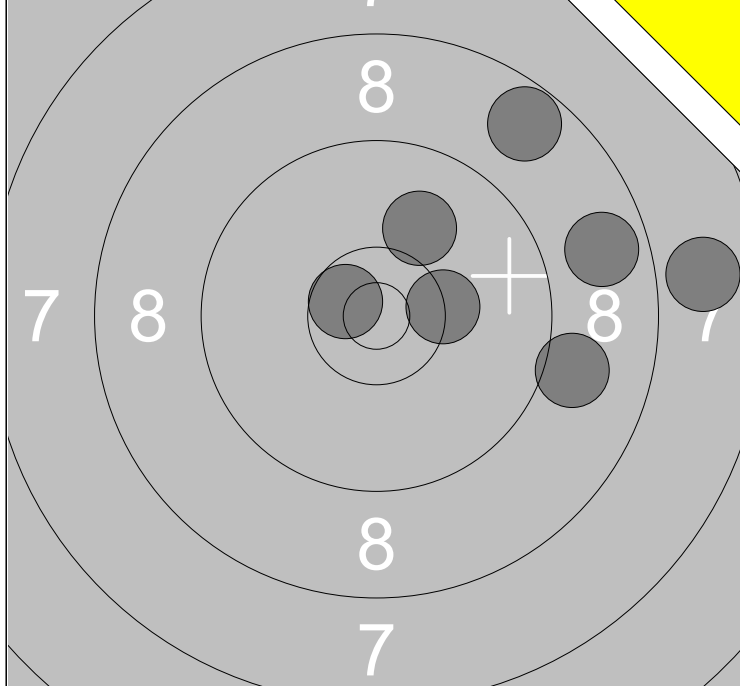

1: 10.0 ↗	6: 8.7 ↗	Serie	62
2: 7.9 →	7: 10.6x ↖		
3: 10.3x →		Total	182
4: 8.7 →			
5: 9.0 →			

1: 9.0 →	Serie	48
2: 10.7x ↗		
3: 10.3 ↗	Total	230
4: 10.3x ↖		
5: 9.5 ↗		

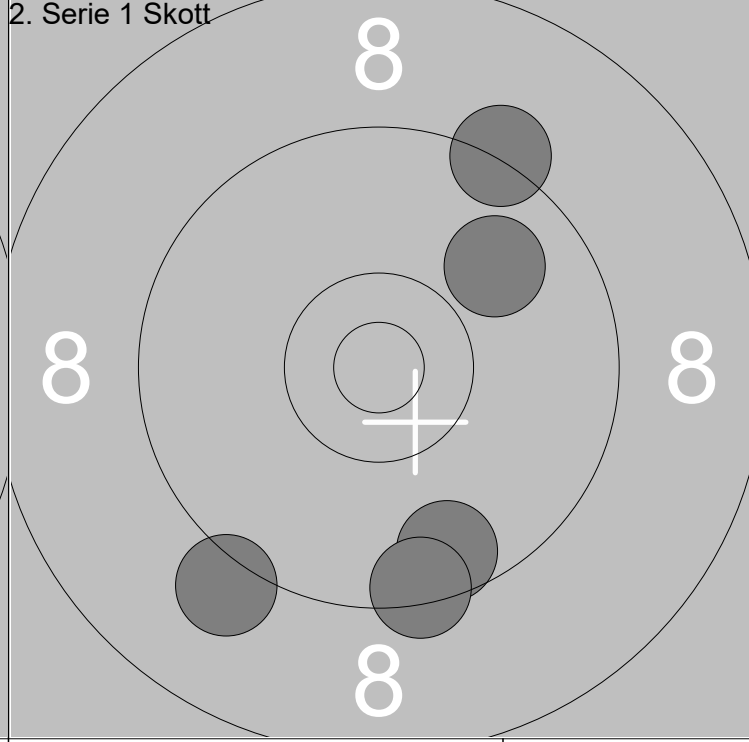
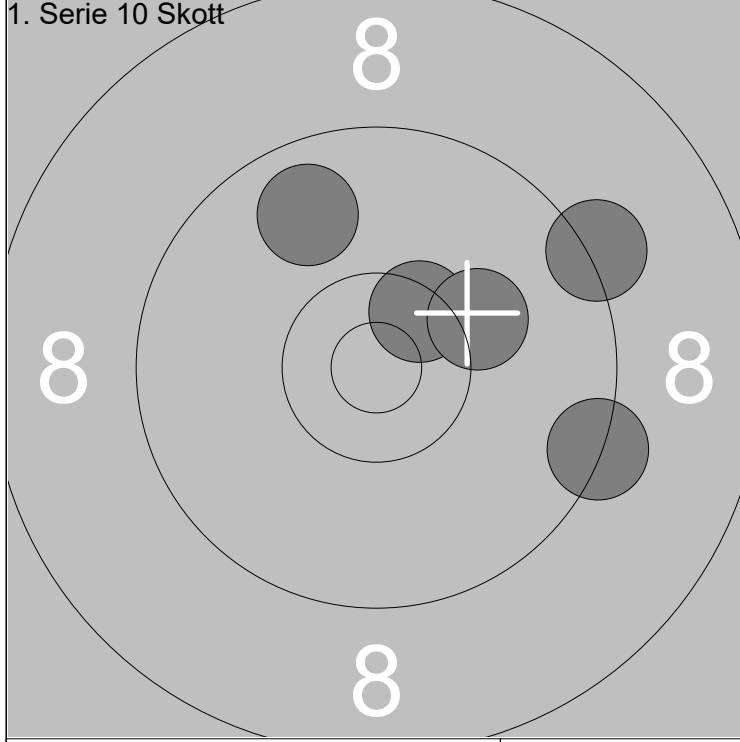

6: 10.5x ↗	Serie	47
7: 10.2 ↗		
8: 9.8 ↗	Total	277
9: 9.2 ↗		
10: 9.3 →		

1: 9.6 ↓	Serie	45
2: 9.3 ↗		
3: 9.9 ↗	Total	322
4: 9.4 ↓		
5: 9.1 ↖		

	<p>1: 9.7 →</p> <p>2: 8.0 →</p> <p>3: 8.4 ↗</p> <p>4: 8.1 →</p> <p>5: 10.7x→</p> <p>6: 10.6x↓</p> <p>7: 9.8 ↗</p> <p>8: 10.3x↘</p> <p>9: 9.7 ↗</p> <p>10: 10.0 ↑</p>		<p>11: 9.3 ↗</p>
Serie 91.0		Serie 9.0	
Total 164.0		Total 164.0	

<p>1. Serie 10 Skott</p>	<p>1: 8.9 ↖</p> <p>2: 7.0 ↖</p> <p>3: 8.4 ↑</p> <p>4: 9.5 ↖</p> <p>5: 9.5 ↘</p>		<p>6: 10.4x↓</p> <p>7: 9.1 ↗</p> <p>8: 9.0 ↘</p> <p>9: 9.9 ↖</p> <p>10: 9.3 ↗</p>
Serie 41.0		Serie 46.0	
Total 205.0		Total 251.0	

<p>2. Serie 1 Skott</p>	<p>1: 8.6 ↑</p> <p>2: 9.6 ↓</p> <p>3: 10.0 →</p> <p>4: 8.9 ↘</p> <p>5: 10.1 ←</p>		
Serie 45.0			
Total 296.0			

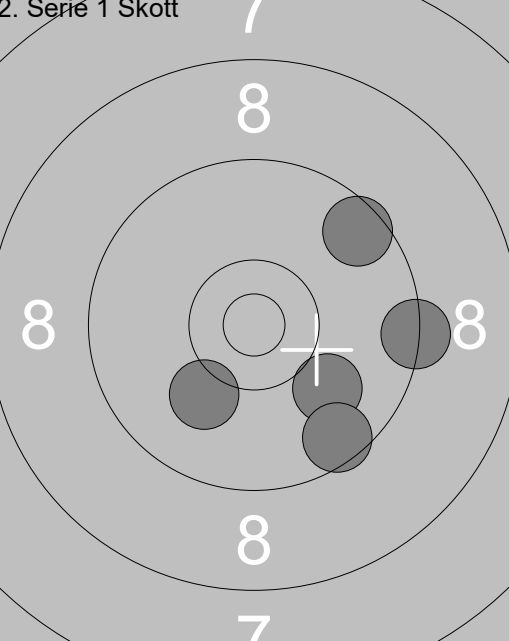
<div style="text-align: center;">Prov</div> 	<table style="width:100%; border-collapse: collapse;"> <tr><td>1: 8.9 ↖</td></tr> <tr><td>2: 10.1 ↑</td></tr> <tr><td>3: 10.3 →</td></tr> <tr><td>4: 10.0 ↘</td></tr> <tr><td>5: 10.1 ↑</td></tr> <tr><td>6: 9.9 ↖</td></tr> <tr><td>7: 9.6 ↑</td></tr> <tr><td>8: 10.1 ↗</td></tr> <tr><td>9: 9.9 →</td></tr> <tr><td>10: 10.0 →</td></tr> <tr><td colspan="2"><hr/></td></tr> <tr><td style="text-align: right;">Serie</td><td style="text-align: left;">95.0</td></tr> <tr><td colspan="2"><hr/></td></tr> <tr><td style="text-align: right;">Total</td><td style="text-align: left;">194.0</td></tr> </table>	1: 8.9 ↖	2: 10.1 ↑	3: 10.3 →	4: 10.0 ↘	5: 10.1 ↑	6: 9.9 ↖	7: 9.6 ↑	8: 10.1 ↗	9: 9.9 →	10: 10.0 →	<hr/>		Serie	95.0	<hr/>		Total	194.0	<div style="text-align: center;">Prov</div> 	<table style="width:100%; border-collapse: collapse;"> <tr><td>11: 10.3x ↘</td></tr> <tr><td colspan="2"><hr/></td></tr> <tr><td style="text-align: right;">Serie</td><td style="text-align: left;">10.0</td></tr> <tr><td colspan="2"><hr/></td></tr> <tr><td style="text-align: right;">Total</td><td style="text-align: left;">194.0</td></tr> </table>	11: 10.3x ↘	<hr/>		Serie	10.0	<hr/>		Total	194.0
1: 8.9 ↖																														
2: 10.1 ↑																														
3: 10.3 →																														
4: 10.0 ↘																														
5: 10.1 ↑																														
6: 9.9 ↖																														
7: 9.6 ↑																														
8: 10.1 ↗																														
9: 9.9 →																														
10: 10.0 →																														
<hr/>																														
Serie	95.0																													
<hr/>																														
Total	194.0																													
11: 10.3x ↘																														
<hr/>																														
Serie	10.0																													
<hr/>																														
Total	194.0																													
<div style="text-align: center;">1. Serie 10 Skott</div> 	<table style="width:100%; border-collapse: collapse;"> <tr><td>1: 10.0 ↘</td></tr> <tr><td>2: 9.9 ↘</td></tr> <tr><td>3: 10.5x ↘</td></tr> <tr><td>4: 10.5x ↘</td></tr> <tr><td>5: 10.4x ↘</td></tr> <tr><td colspan="2"><hr/></td></tr> <tr><td style="text-align: right;">Serie</td><td style="text-align: left;">49.0</td></tr> <tr><td colspan="2"><hr/></td></tr> <tr><td style="text-align: right;">Total</td><td style="text-align: left;">243.0</td></tr> </table>	1: 10.0 ↘	2: 9.9 ↘	3: 10.5x ↘	4: 10.5x ↘	5: 10.4x ↘	<hr/>		Serie	49.0	<hr/>		Total	243.0	<div style="text-align: center;">1. Serie 10 Skott</div> 	<table style="width:100%; border-collapse: collapse;"> <tr><td>6: 10.3 ↘</td></tr> <tr><td>7: 10.1 ↑</td></tr> <tr><td>8: 10.1 ↗</td></tr> <tr><td>9: 10.3 →</td></tr> <tr><td>10: 10.3x →</td></tr> <tr><td colspan="2"><hr/></td></tr> <tr><td style="text-align: right;">Serie</td><td style="text-align: left;">50.0</td></tr> <tr><td colspan="2"><hr/></td></tr> <tr><td style="text-align: right;">Total</td><td style="text-align: left;">293.0</td></tr> </table>	6: 10.3 ↘	7: 10.1 ↑	8: 10.1 ↗	9: 10.3 →	10: 10.3x →	<hr/>		Serie	50.0	<hr/>		Total	293.0	
1: 10.0 ↘																														
2: 9.9 ↘																														
3: 10.5x ↘																														
4: 10.5x ↘																														
5: 10.4x ↘																														
<hr/>																														
Serie	49.0																													
<hr/>																														
Total	243.0																													
6: 10.3 ↘																														
7: 10.1 ↑																														
8: 10.1 ↗																														
9: 10.3 →																														
10: 10.3x →																														
<hr/>																														
Serie	50.0																													
<hr/>																														
Total	293.0																													
<div style="text-align: center;">2. Serie 1 Skott</div> 	<table style="width:100%; border-collapse: collapse;"> <tr><td>1: 10.1 ↘</td></tr> <tr><td>2: 10.0 ↘</td></tr> <tr><td>3: 9.3 →</td></tr> <tr><td>4: 9.6 ↗</td></tr> <tr><td>5: 9.6 ↘</td></tr> <tr><td colspan="2"><hr/></td></tr> <tr><td style="text-align: right;">Serie</td><td style="text-align: left;">47.0</td></tr> <tr><td colspan="2"><hr/></td></tr> <tr><td style="text-align: right;">Total</td><td style="text-align: left;">340.0</td></tr> </table>	1: 10.1 ↘	2: 10.0 ↘	3: 9.3 →	4: 9.6 ↗	5: 9.6 ↘	<hr/>		Serie	47.0	<hr/>		Total	340.0																
1: 10.1 ↘																														
2: 10.0 ↘																														
3: 9.3 →																														
4: 9.6 ↗																														
5: 9.6 ↘																														
<hr/>																														
Serie	47.0																													
<hr/>																														
Total	340.0																													

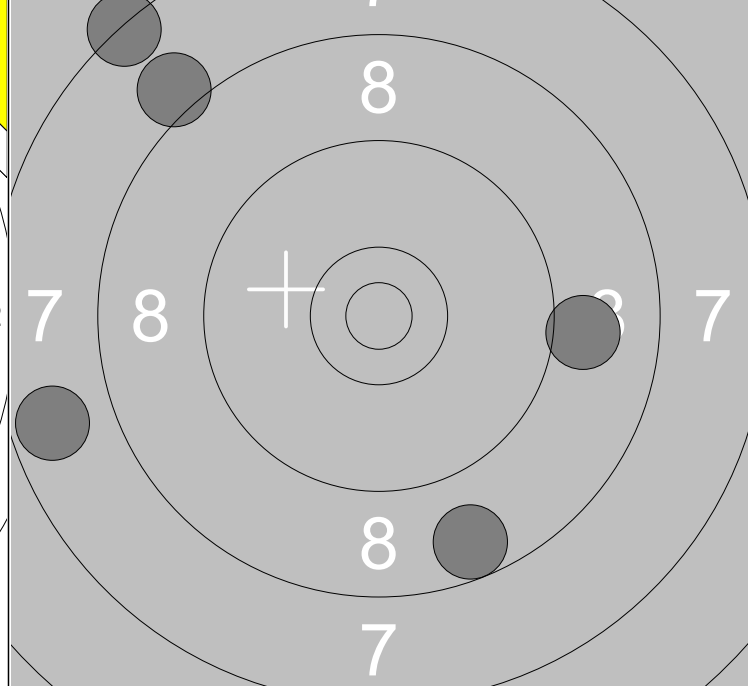
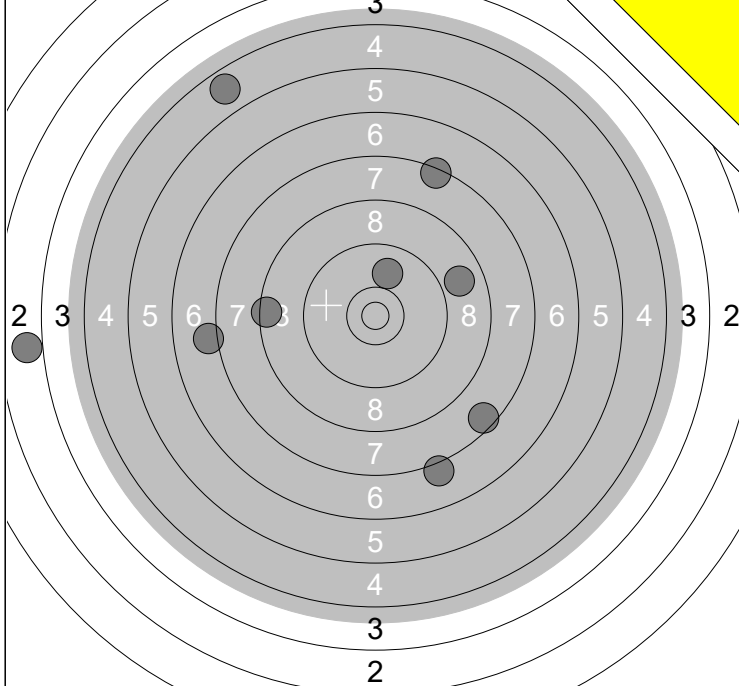

1: 7.1 ←	6: 7.1 ↓	Serie	59
2: 8.9 →	7: 8.5 ←		
3: 4.7 ↗	8: 7.5 ↓	Total	153
4: 7.4 ↗	9: 9.9 ↗		
5: 2.9 ←			

1: 7.3 ↗	Serie	39
2: 8.7 ↓		
3: 8.1 ↗	Total	192
4: 7.7 ←		
5: 9.0 →		

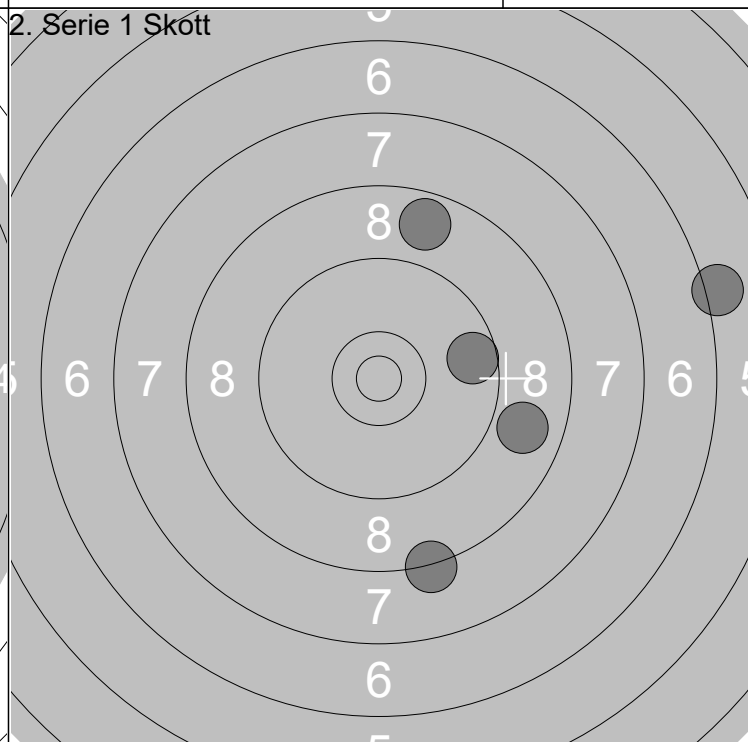
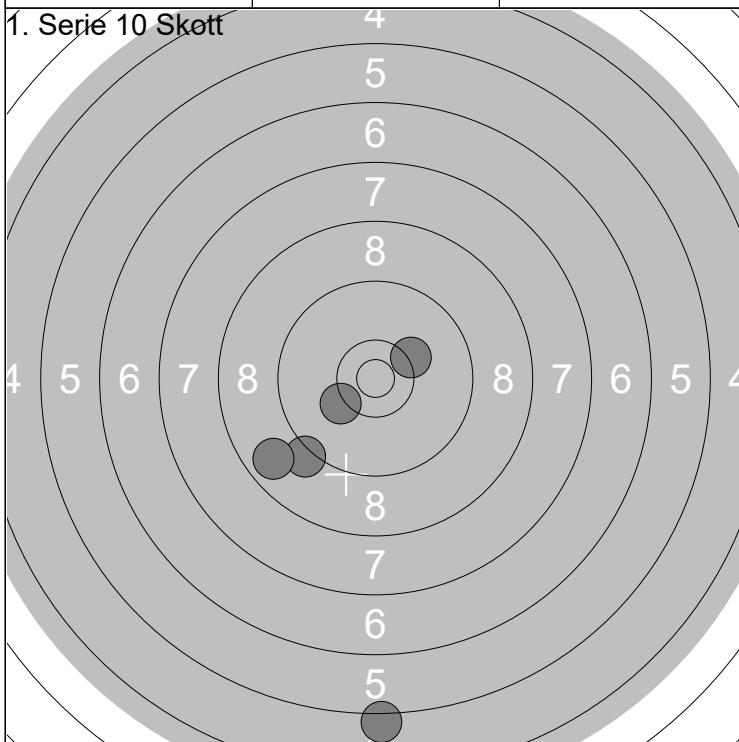

6: 10.2 ↗	Serie	42
7: 9.2 ↓		
8: 10.2 ←	Total	234
9: 8.8 ←		
10: 5.2 ↓		

1: 8.3 ↓	Serie	39
2: 8.9 →		
3: 9.6 →	Total	273
4: 8.7 ↗		
5: 6.1 →		

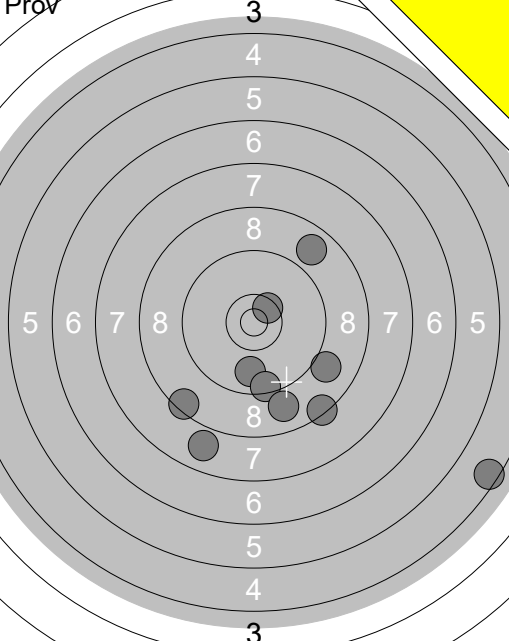
	<p>1: 4.5 ↘</p> <p>2: 9.0 ↘</p> <p>3: 8.8 ↗</p> <p>4: 7.9 ↓</p> <p>5: 8.4 ↓</p> <p>6: 10.5x ↗</p> <p>7: 9.8 ↓</p> <p>8: 9.5 ↓</p> <p>9: 8.5 ↙</p> <p>10: 8.9 ↓</p>		<p>11: 10.4x ↓</p> <p>12: 8.8 →</p> <p>13: 9.7 ↖</p>
Serie 80.0		Serie 27.0	
Total 145.0		Total 145.0	

<p>1. Serie 10 Skott</p> 	<p>1: 8.7 ↖</p> <p>2: 9.8 ↓</p> <p>3: 9.4 ↓</p> <p>4: 8.8 →</p> <p>5: 9.3 →</p>	<p>1. Serie 10 Skott</p> 	<p>6: 8.9 ↗</p> <p>7: 8.3 ↗</p> <p>8: 8.3 →</p> <p>9: 6.1 →</p> <p>10: 9.5 ↙</p>
Serie 43.0		Serie 39.0	
Total 188.0		Total 227.0	

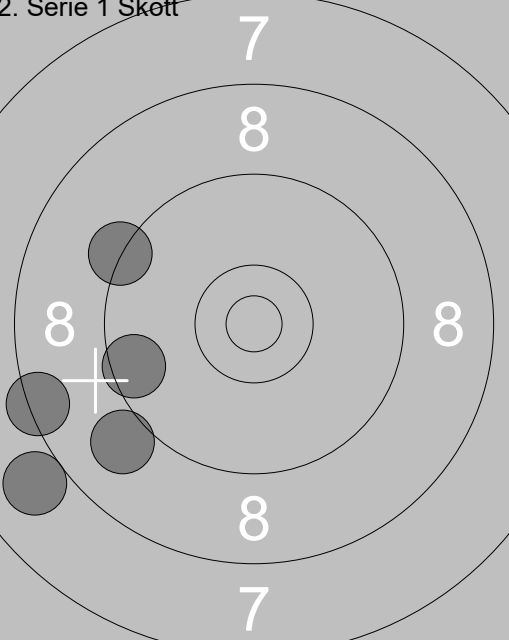
<p>2. Serie 1 Skott</p> 	<p>1: 9.5 ↙</p> <p>2: 9.3 ↖</p> <p>3: 9.0 ↙</p> <p>4: 8.4 ←</p> <p>5: 8.0 ↙</p>		
Serie 43.0			
Total 270.0			

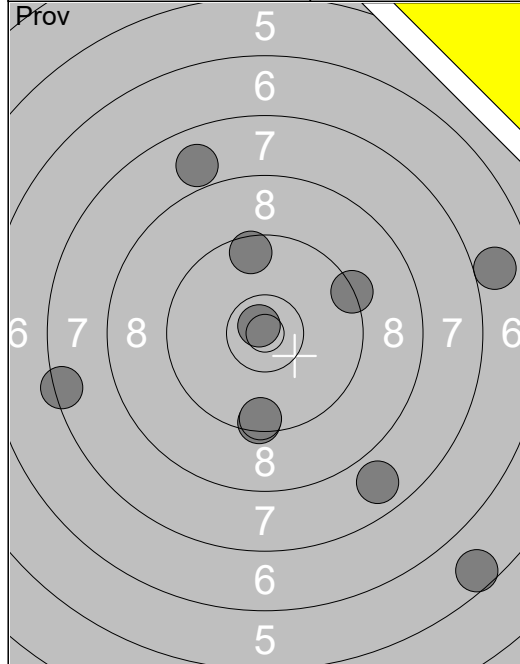

1:	9.4	↓
2:	6.9	→
3:	10.8	↘
4:	5.6	↓
5:	7.9	↑
6:	9.3	→
7:	7.4	←
8:	9.5	↓
9:	9.6	↑
10:	7.8	↓
Serie		78.0
Total		142.0

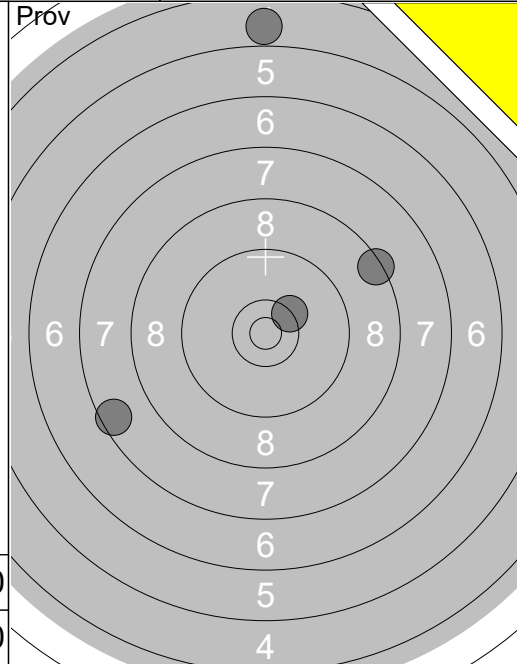

11:	7.5	↙
12:	4.9	↑
13:	8.4	↗
14:	10.3	↘
Serie		29.0
Total		142.0

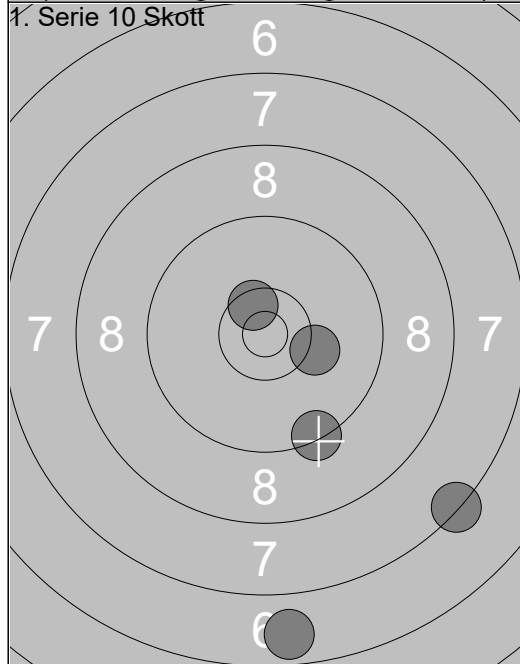

1:	9.4	↓
2:	7.3	↓
3:	10.5	↘
4:	10.2	→
5:	6.7	↓
Serie		42.0
Total		184.0

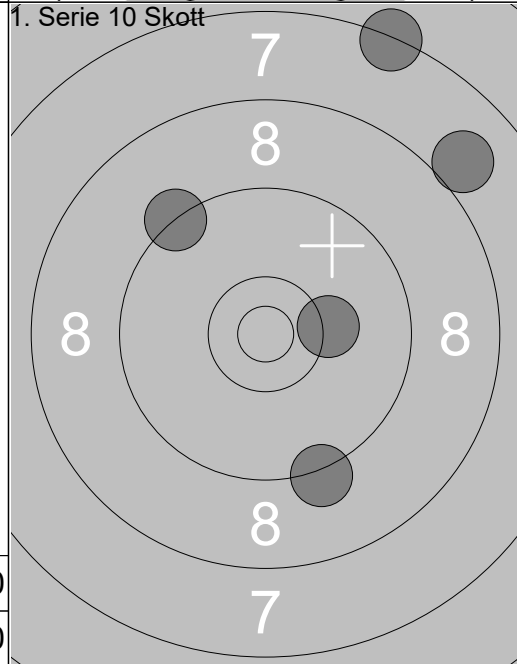

6:	9.2	↓
7:	10.2	→
8:	9.3	↖
9:	7.3	↑
10:	8.0	↗
Serie		43.0
Total		227.0

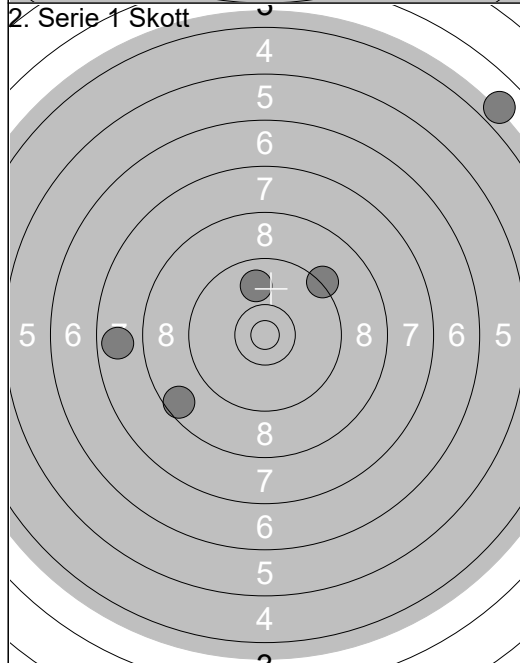

1:	3.9	↗
2:	9.9	↑
3:	8.6	↙
4:	7.7	←
5:	9.3	↗
Serie		36.0
Total		263.0

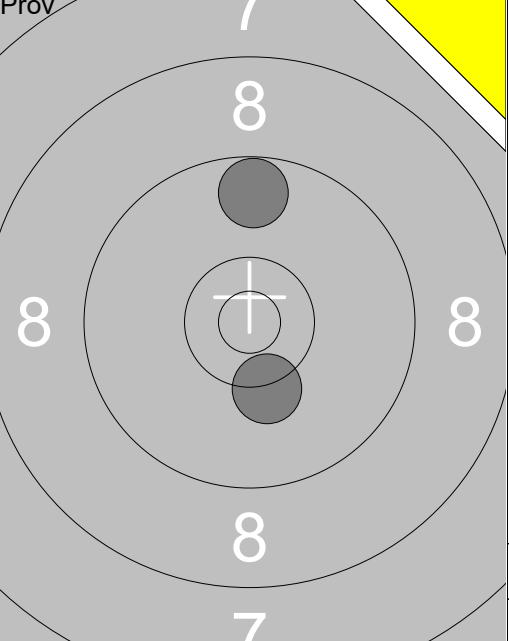
	<p>1: 9.2 ↙</p> <p>2: 8.9 ➤</p> <p>3: 9.3 ↓</p> <p>4: 10.5x↘</p> <p>5: 10.3x↘</p> <p>6: 10.5x➔</p> <p>7: 10.1➔</p> <p>8: 10.4x➔</p> <p>9: 10.8x➔</p> <p>10: 10.8x↗</p>		<p>11: 9.7 ↑</p> <p>12: 10.3 ↓</p>
Serie 96.0		Serie 19.0	
Total 183.0		Total 183.0	

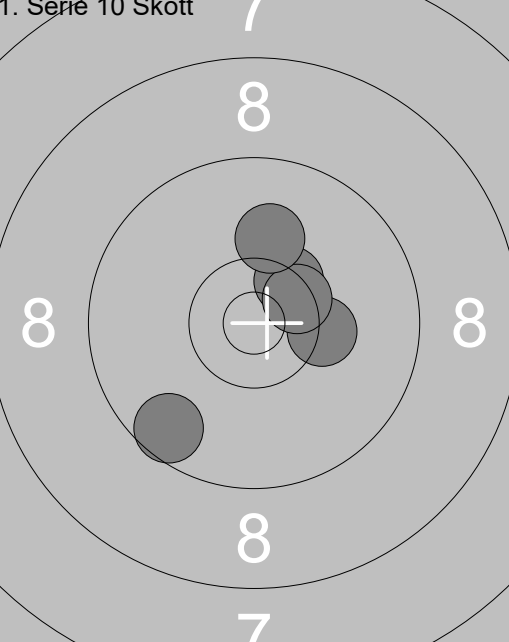
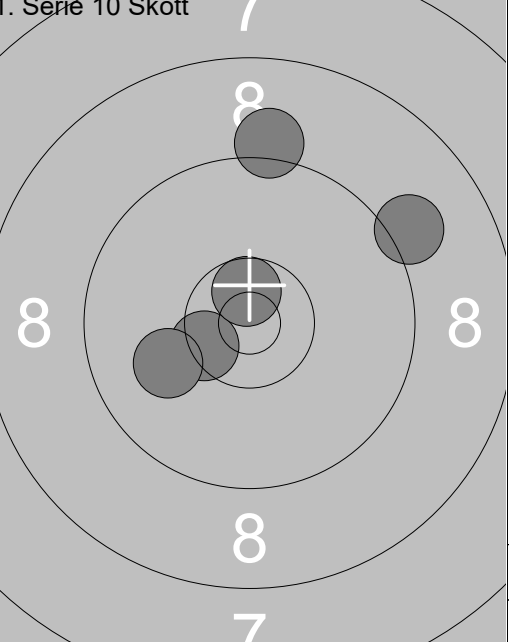
<p>1. Serie 10 Skott</p> 	<p>1: 10.4x↗</p> <p>2: 10.3➔</p> <p>3: 10.5x↗</p> <p>4: 10.1↑</p> <p>5: 9.6 ↙</p>		<p>6: 10.4x↘</p> <p>7: 10.0↙</p> <p>8: 10.6x↑</p> <p>9: 9.1 ↗</p> <p>10: 9.1 ↑</p>
Serie 49.0		Serie 48.0	
Total 232.0		Total 280.0	

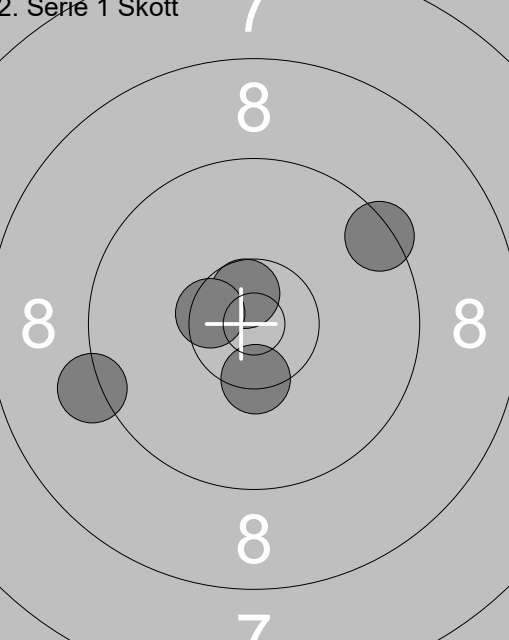
<p>2. Serie 1 Skott</p> 	<p>1: 10.4x↓</p> <p>2: 10.6x↘</p> <p>3: 9.2 ↙</p> <p>4: 10.5x↘</p> <p>5: 9.4 ↗</p>		
Serie 48.0			
Total 328.0			

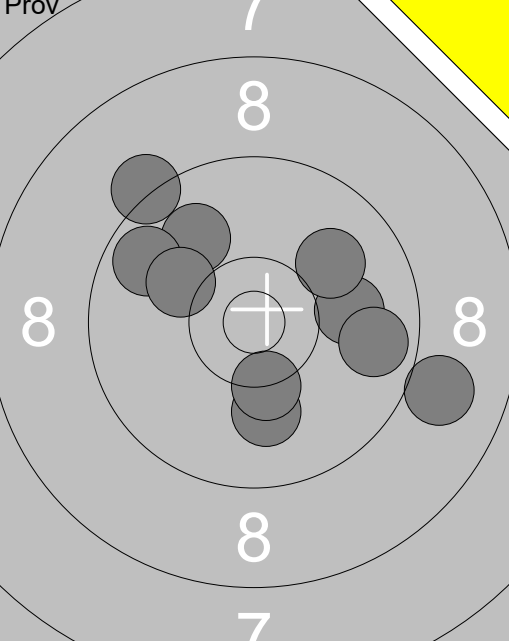
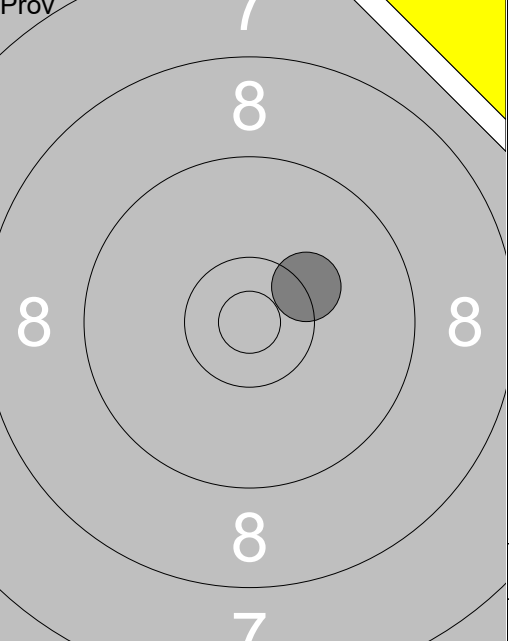
Prov		Prov	
	<p>1: 10.1 ↓</p> <p>2: 10.0 →</p> <p>3: 9.9 ↗</p> <p>4: 9.7 →</p> <p>5: 9.2 ↗</p> <p>6: 9.7 ↖</p> <p>7: 10.0 ↗</p> <p>8: 10.1 ↖</p> <p>9: 9.0 →</p> <p>10: 10.3x ↓</p>		<p>11: 10.3 ↗</p>
Serie	95.0	Serie	10.0
Total	195.0	Total	195.0

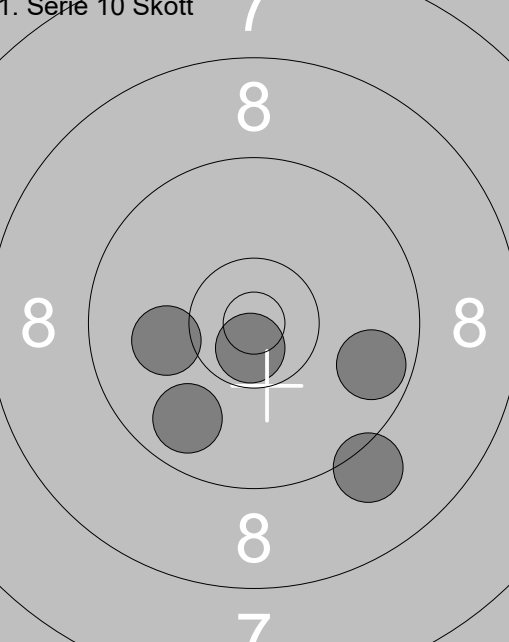
1. Serie 10 Skott		1. Serie 10 Skott	
	<p>1: 9.8 ↓</p> <p>2: 10.1 ←</p> <p>3: 10.7x ↓</p> <p>4: 9.7 →</p> <p>5: 9.1 ↓</p>		<p>6: 10.3x ↖</p> <p>7: 10.1 ↓</p> <p>8: 9.5 ↓</p> <p>9: 8.3 →</p> <p>10: 9.7 ←</p>
Serie	47.0	Serie	46.0
Total	242.0	Total	288.0

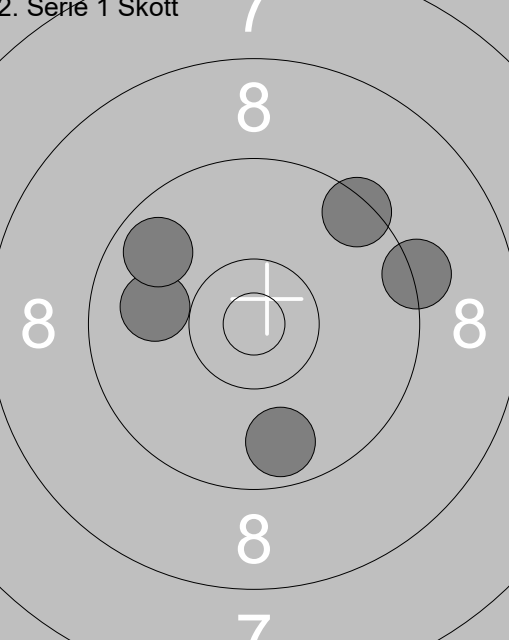
2. Serie 1 Skott			
	<p>1: 9.9 ←</p> <p>2: 9.8 ↖</p> <p>3: 9.7 ↓</p> <p>4: 9.4 ↗</p> <p>5: 9.3 →</p>		
Serie	45.0		
Total	333.0		

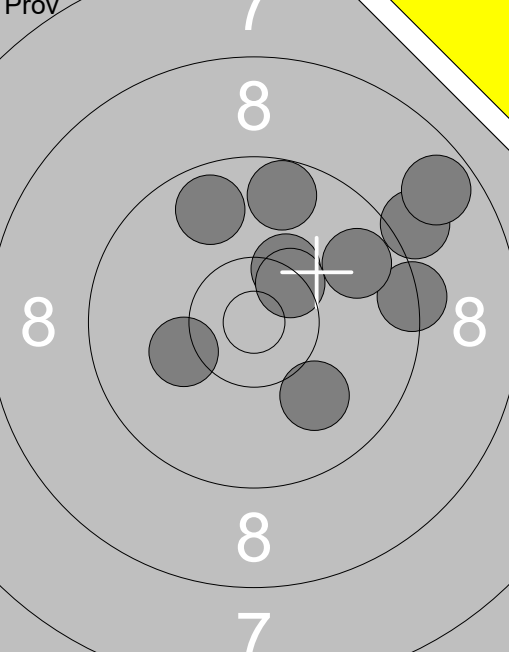
	<p>1: 10.3x ↗</p> <p>2: 9.1 →</p> <p>3: 9.4 →</p> <p>4: 10.4x ↗</p> <p>5: 8.7 →</p> <p>6: 9.7 ↑</p> <p>7: 9.8 →</p> <p>8: 10.0 ↘</p> <p>9: 10.2 ↙</p> <p>10: 9.7 ↑</p>	<p>11: 10.3x ↗</p> <p>12: 10.1 ↘</p> <p>13: 9.8 →</p> <p>14: 9.2 →</p> <p>15: 9.5 →</p>
Serie 93.0		Serie 47.0
Total 195.0		Total 195.0

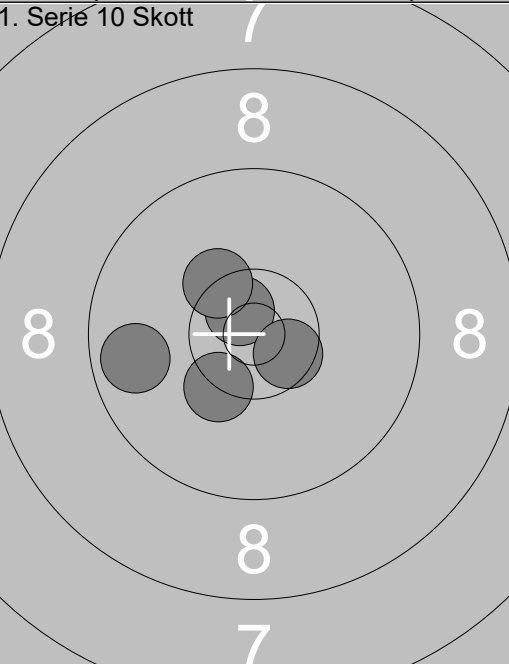
<p>1. Serie 10 Skott</p> 	<p>1: 10.7x ↘</p> <p>2: 10.3x ↘</p> <p>3: 10.3x ↘</p> <p>4: 10.6x ↘</p> <p>5: 9.7 ←</p>	<p>6: 9.2 →</p> <p>7: 10.1 ↘</p> <p>8: 9.7 ←</p> <p>9: 9.5 →</p> <p>10: 10.9x ↘</p>
Serie 49.0		Serie 47.0
Total 244.0		Total 291.0

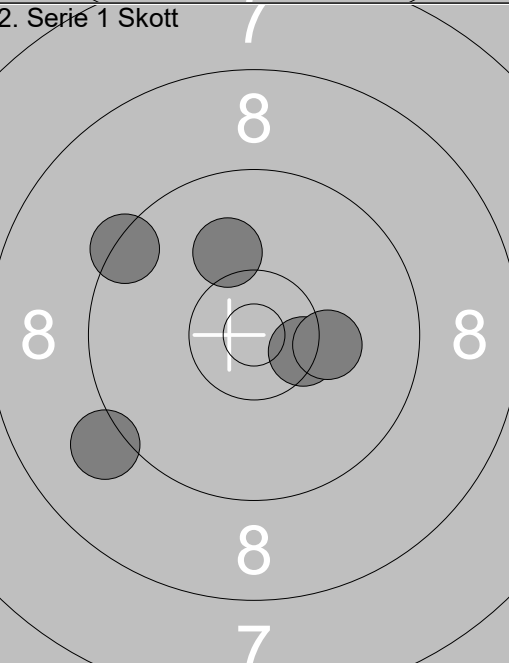
<p>2. Serie 1 Skott</p> 	<p>1: 9.4 ↙</p> <p>2: 9.1 ↙</p> <p>3: 10.4x →</p> <p>4: 10.2 →</p> <p>5: 10.1 ↑</p>	
Serie 48.0		
Total 339.0		

Skjutlag

5

Tavla

3

Casper Fredriksson

Ramselefors

Ramselefors

Sen-L

Vb

09.07.2024

Tavelträffen Korthåll 2024

Ramselefors SKF

Prov



1. Serie 10 Skott

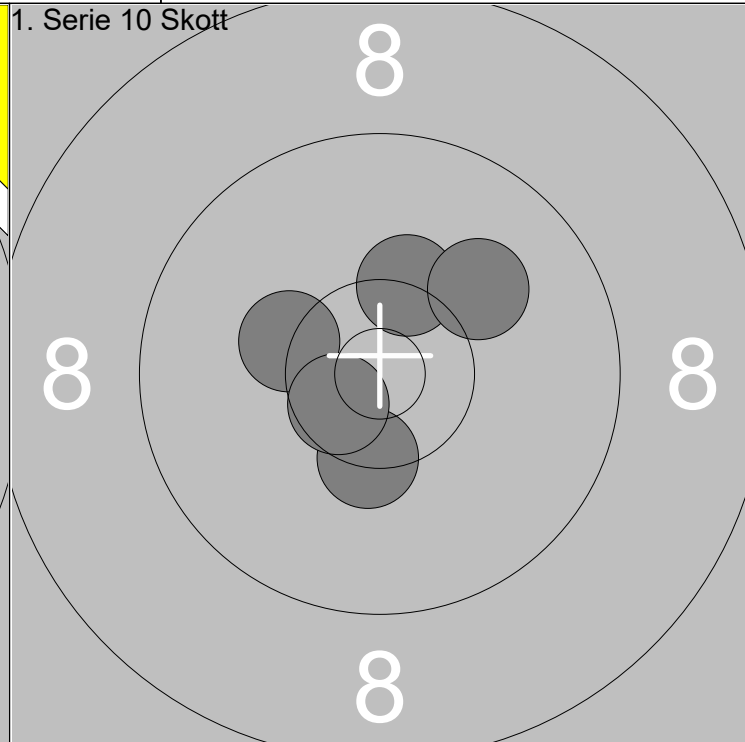

1: 10.6x ↙

2: 10.2 →

3: 10.3x ↘

4: 10.7x ↙

5: 10.2 →

6: 10.1 ↗

7: 10.0 ←

8: 9.7 ↓

9: 10.1 →

10: 10.5x ↓

Serie 99

Total 194

1: 10.3x ↗

2: 10.1 ↗

3: 10.3 ↙

4: 10.4x ↓

5: 10.6x ↙

Serie 50

Total 244

1. Serie 10 Skott

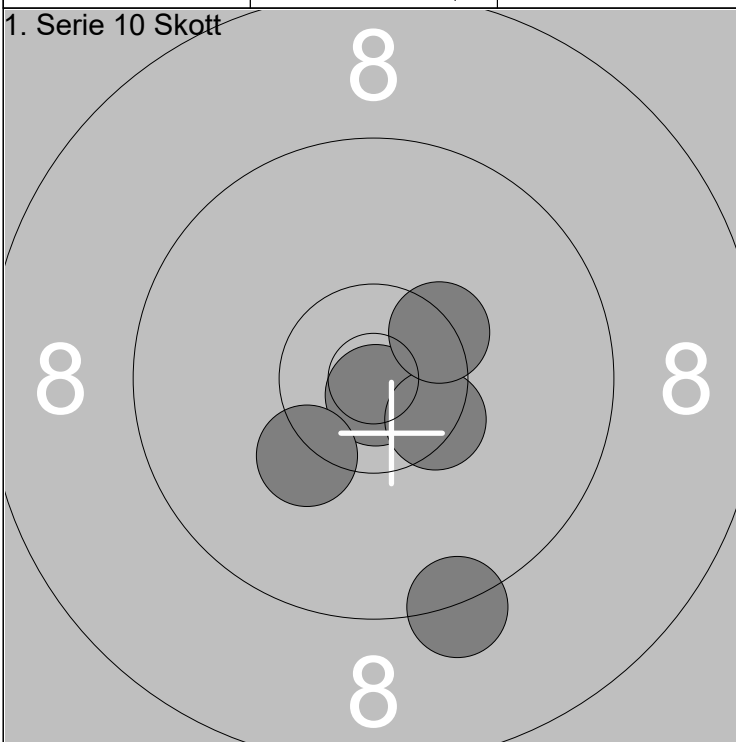

2. Serie 1 Skott

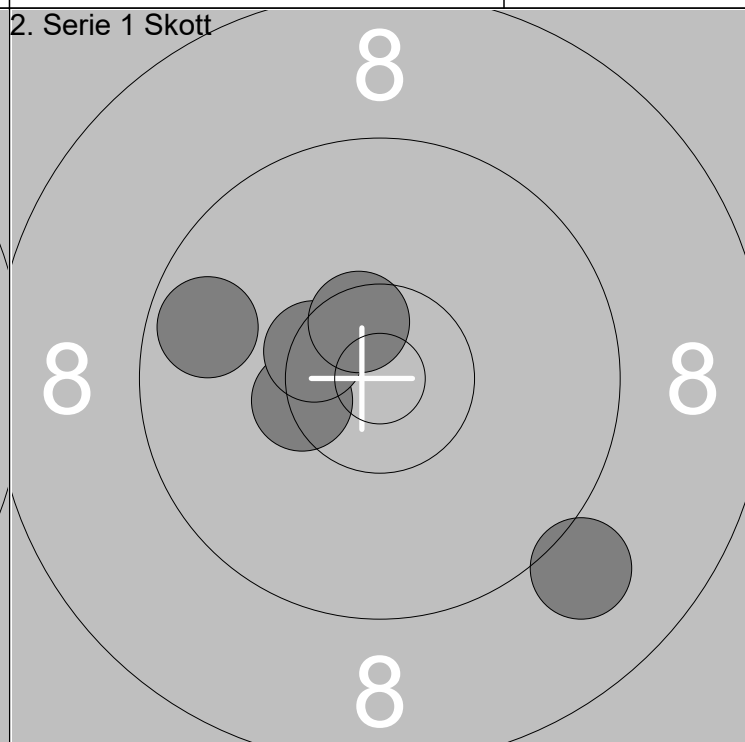

6: 10.8x ↓

7: 9.3 ↓

8: 10.4x ↘

9: 10.3 ↙

10: 10.4x ↗

Serie 49

Total 293

1: 9.7 ↙

2: 10.4x ↙

3: 10.5x ↙

4: 9.1 ↘

5: 10.5x ↗

Serie 48

Total 341

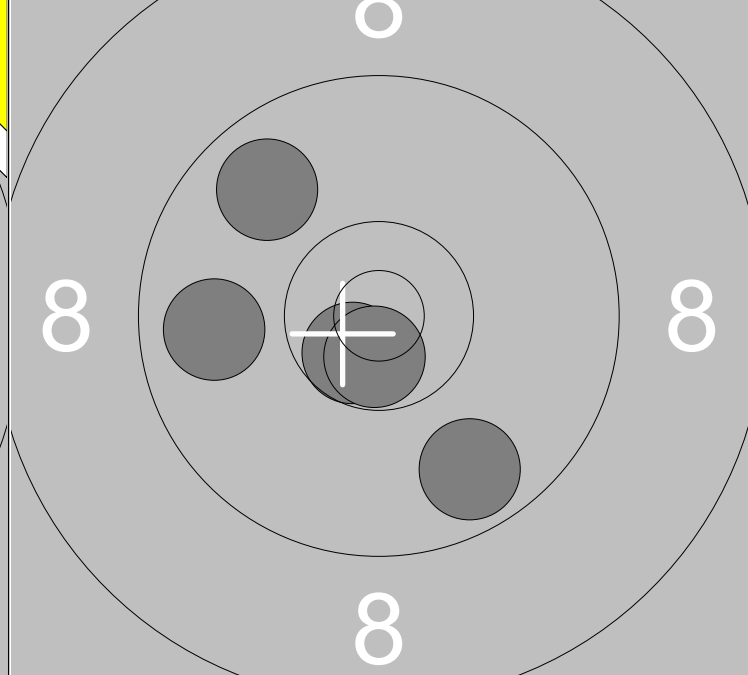
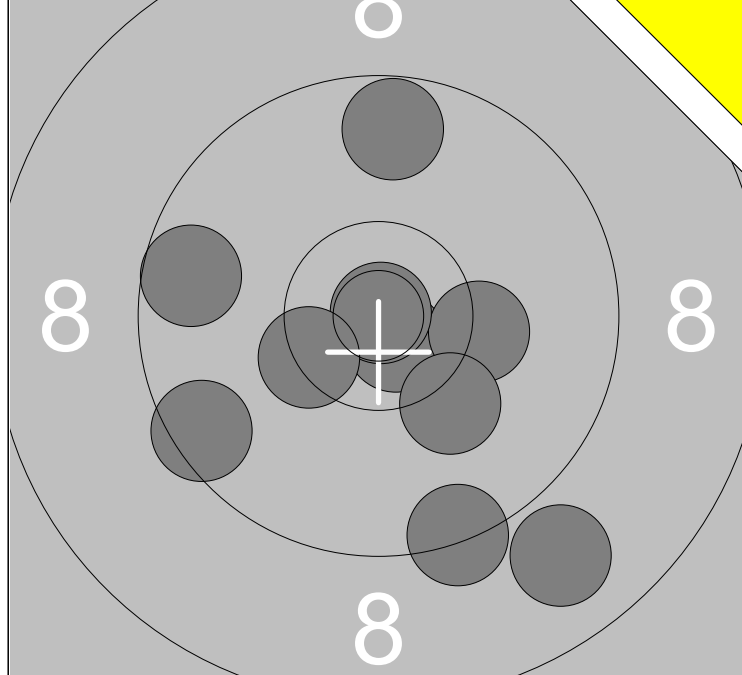

1: 9.3 ↓	6: 9.6 ←	Serie	94
2: 10.7x ↓	7: 10.4x ↙		
3: 10.3 →	8: 8.9 ↓	Total	194
4: 9.7 ↑	9: 9.5 ↙		
5: 10.9x ↗	10: 10.2 ↓		

1: 9.8 ↗	Serie	47
2: 9.8 ←		
3: 9.7 ↓	Total	241
4: 10.6x ↙		
5: 10.7x ↓		

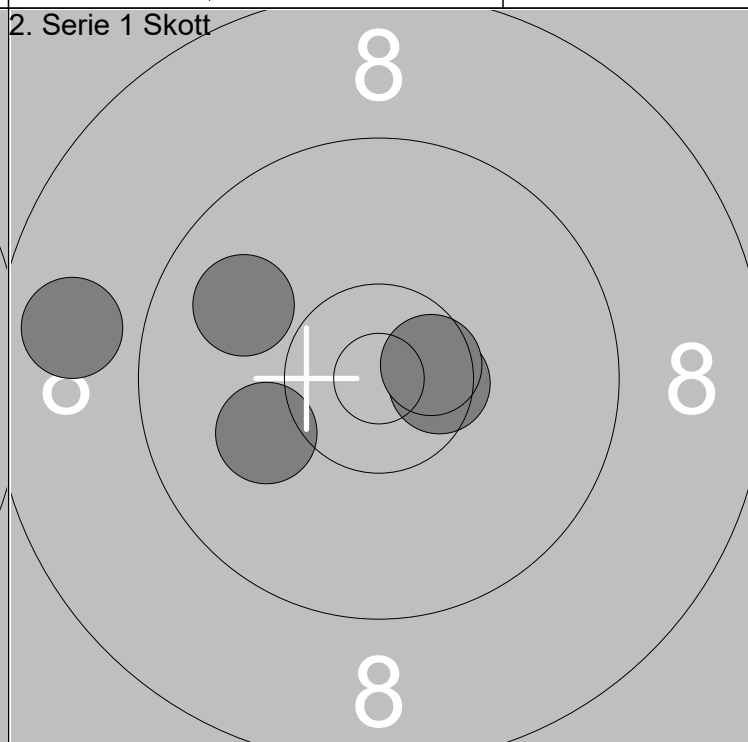
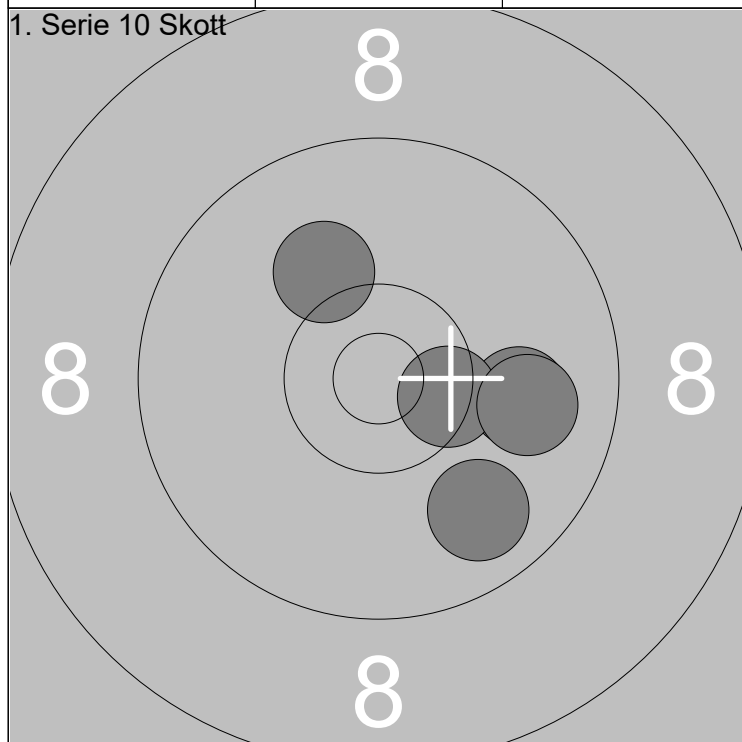

6: 9.8 ↓	Serie	48
7: 10.1 ↗		
8: 10.0 →	Total	289
9: 10.5x →		
10: 9.9 →		

1: 8.8 ←	Serie	47
2: 10.5x →		
3: 9.9 ↗	Total	336
4: 10.1 ↙		
5: 10.6x →		

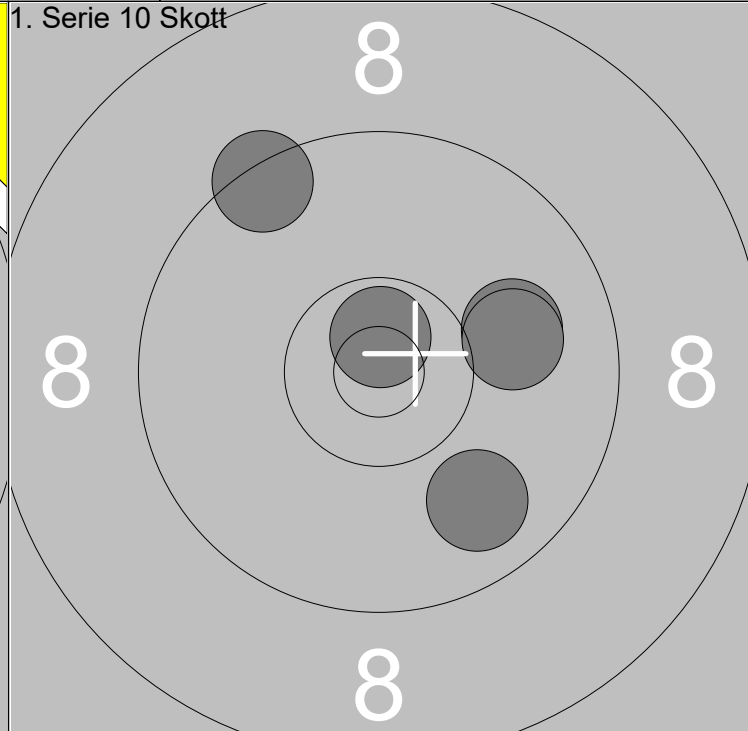
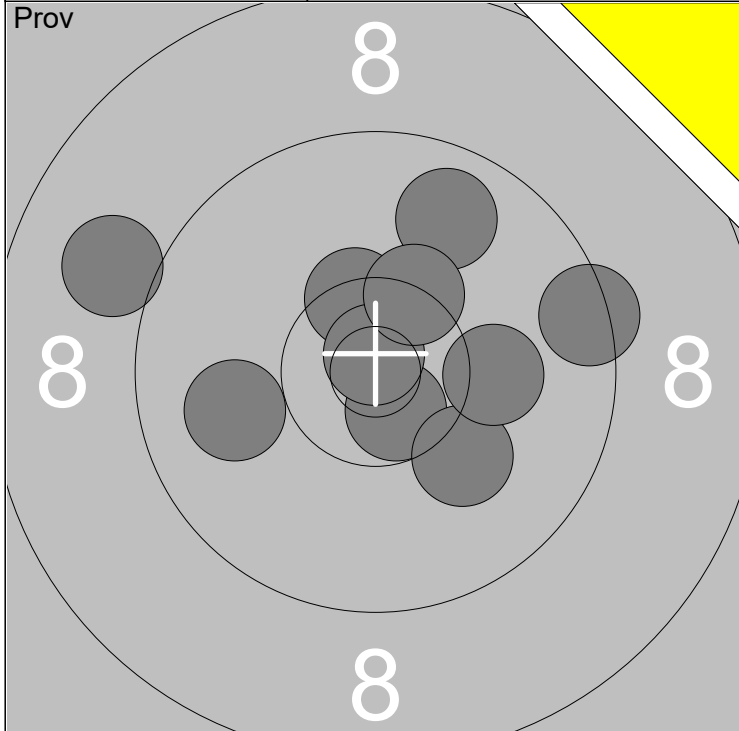

1: 10.4x ↗	6: 10.1 ↘	Serie	96
2: 10.7x ↘	7: 9.8 ↗		
3: 10.8x ↗	8: 10.1 →	Total	194
4: 9.0 ↖	9: 10.4x ↗		
5: 9.9 ←	10: 9.4 →		

1: 9.4 ↖	Serie	48
2: 10.0 →		
3: 9.8 ↘	Total	242
4: 10.7x ↗		
5: 10.0 →		

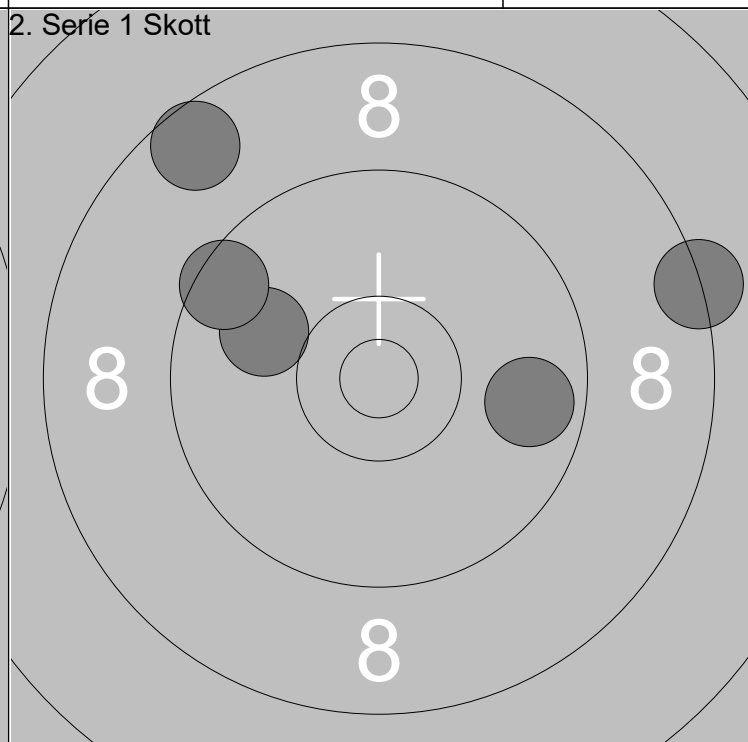
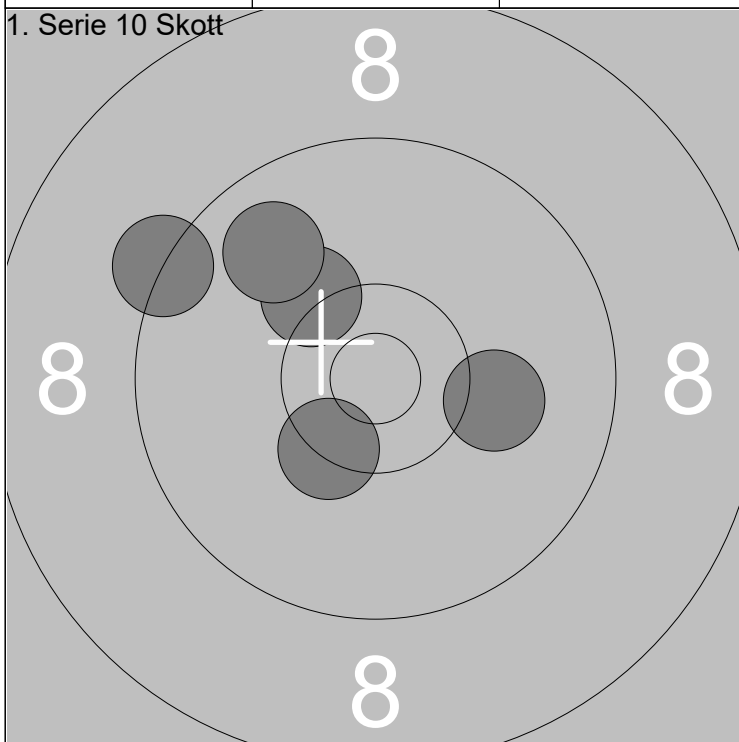

6: 10.2 ↗	Serie	48
7: 9.8 ↗		
8: 10.4x ↘	Total	290
9: 10.1 →		
10: 9.3 ↖		

1: 8.6 ↗	Serie	44
2: 10.0 ↖		
3: 9.5 ↗	Total	334
4: 8.3 →		
5: 9.7 →		

	<p>1: 9.4 ↙</p> <p>2: 9.4 ↘</p> <p>3: 9.2 →</p> <p>4: 8.6 →</p> <p>5: 9.5 ↗</p> <p>6: 9.3 ↖</p> <p>7: 9.7 →</p> <p>8: 10.0 →</p> <p>9: 9.0 ↗</p> <p>10: 10.5x ↘</p>	<p>11: 9.7 ←</p> <p>12: 9.6 ←</p> <p>13: 9.6 ↑</p> <p>14: 10.2 ↖</p> <p>15: 10.8x ↘</p>
Serie 91.0		Serie 47.0
Total 193.0		Total 193.0

<p>1. Serie 10 Skott</p>	<p>1: 10.0 ←</p> <p>2: 10.3 →</p> <p>3: 10.3 ↘</p> <p>4: 10.2 →</p> <p>5: 9.1 ↘</p>	<p>6: 10.3x ↗</p> <p>7: 10.1 ←</p> <p>8: 10.5x ↗</p> <p>9: 8.4 →</p> <p>10: 10.2 ↘</p>
Serie 49.0		Serie 48.0
Total 242.0		Total 290.0

<p>2. Serie 1 Skott</p>	<p>1: 7.2 ←</p> <p>2: 8.9 ↘</p> <p>3: 9.7 →</p> <p>4: 9.4 ↓</p> <p>5: 9.7 ↙</p>	
Serie 42.0		
Total 332.0		

Skjutlag

Tavla

5

7

Kasper Svensson

Ramselefors

Skölvne-Ölanda

Sen-L

Vg

09.07.2024

Tavelträffen Korthåll 2024

Ramselefors SKF

Prov

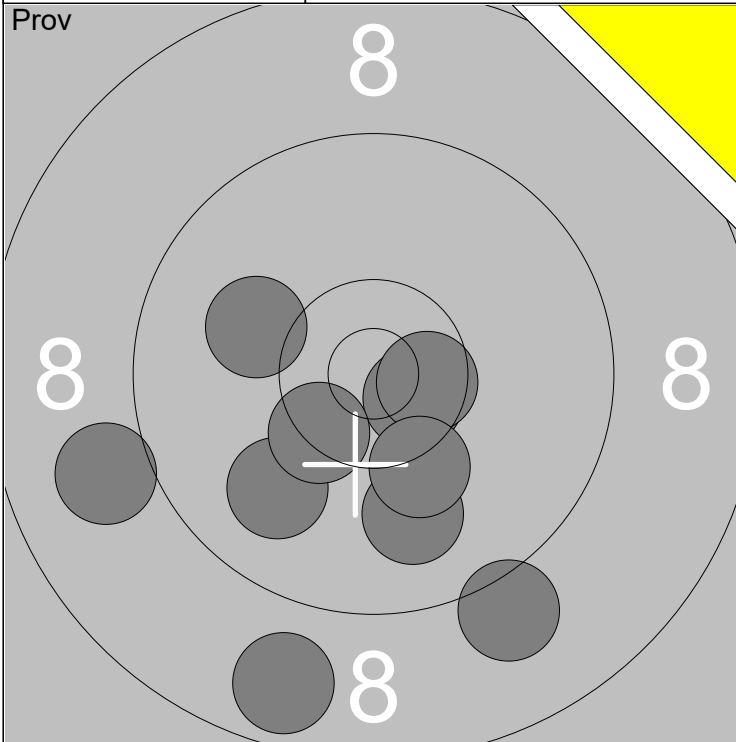

1. Serie 10 Skott

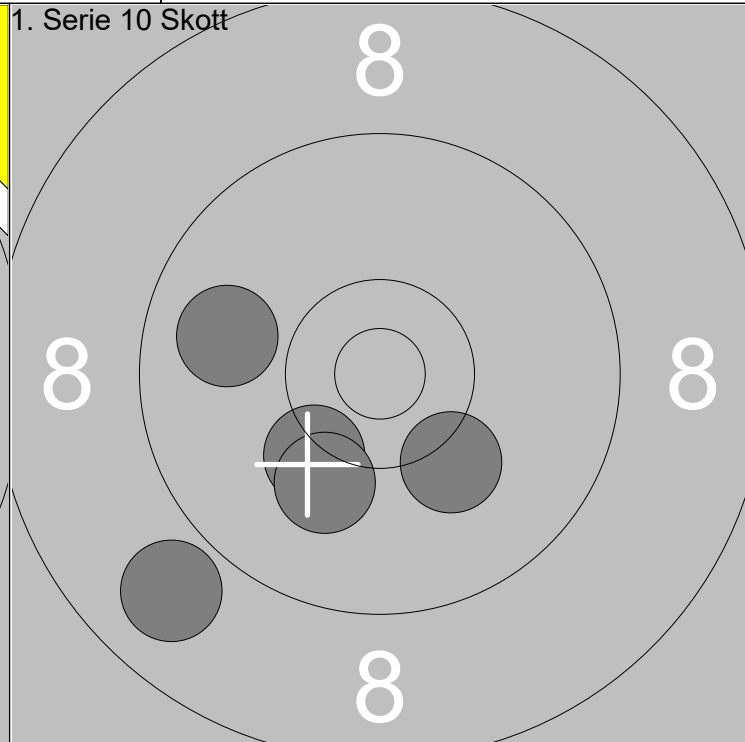

1: 9.1 ↘
2: 10.0 ↘
3: 9.9 ↘
4: 8.7 ↘
5: 10.1 ↙

6: 9.0 ←
7: 10.6x ↘
8: 10.4x ↘
9: 10.6x →
10: 10.2 ↘

Serie 95
Total 191

1: 10.2 ↙
2: 8.9 ↘
3: 10.2 ↘
4: 9.9 ↙
5: 10.1 ↘

Serie 47
Total 238

1. Serie 10 Skott

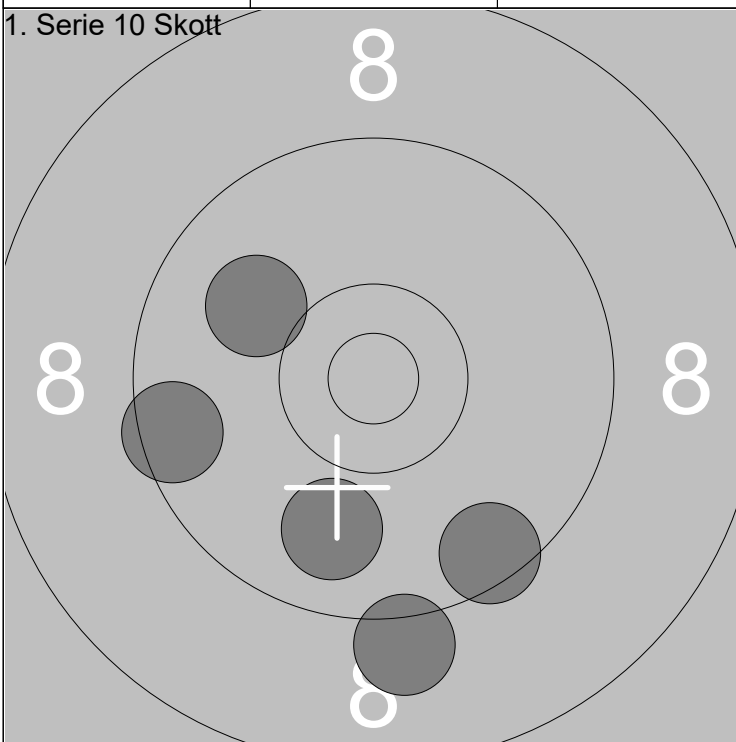

2. Serie 1 Skott

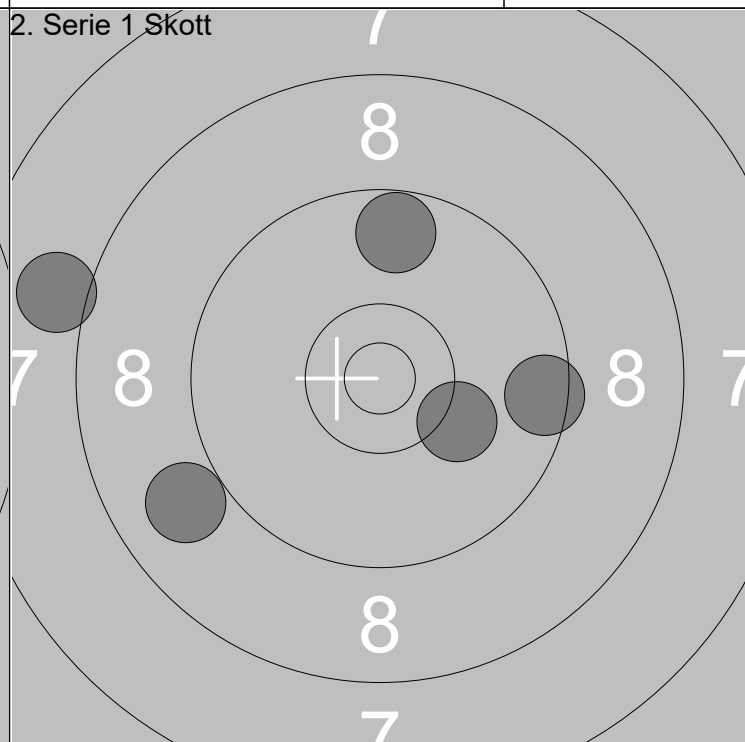

6: 10.0 ↗
7: 9.5 ←
8: 9.9 ↘
9: 9.1 ↘
10: 9.5 ↘

Serie 46
Total 284

1: 8.0 ←
2: 8.9 ↘
3: 10.2 ↘
4: 9.5 →
5: 9.7 ↑

Serie 44
Total 328

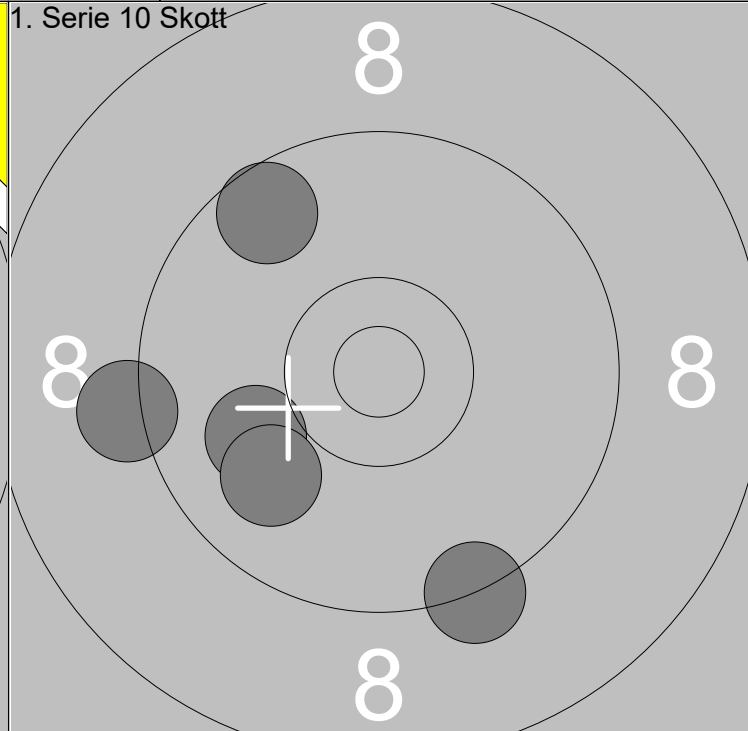
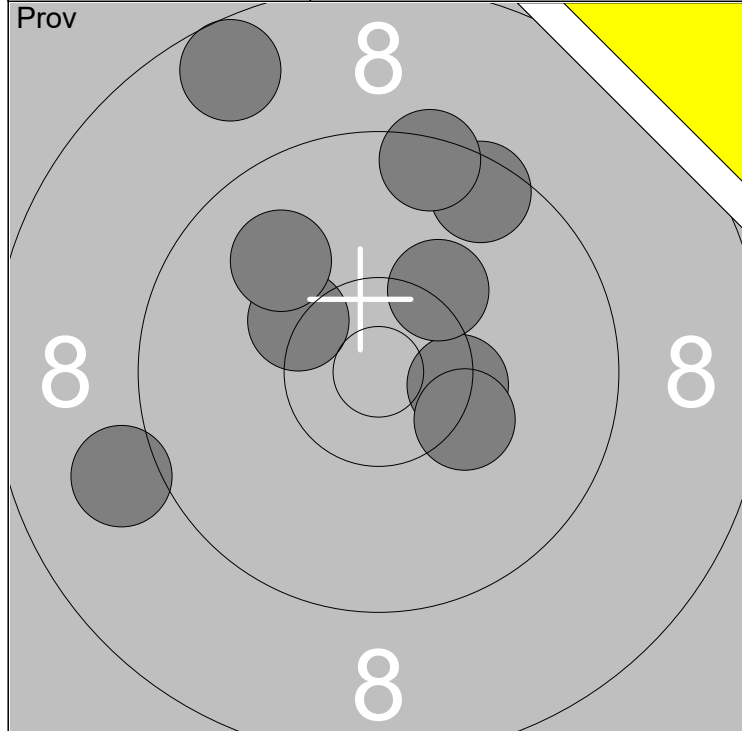

1: 8.6 ↗	7: 10.3 ↗	Serie	84
2: 10.3x ↖	8: 9.9 ↗		
4: 9.5 ↗	9: 10.3 ↘	Total	191
5: 9.5 ↗	10: 9.0 ←		
6: 10.4x →			

1: 9.2 ←	Serie	46
2: 9.3 ↘		
3: 9.6 ↗	Total	237
4: 10.0 ←		
5: 9.9 ↘		

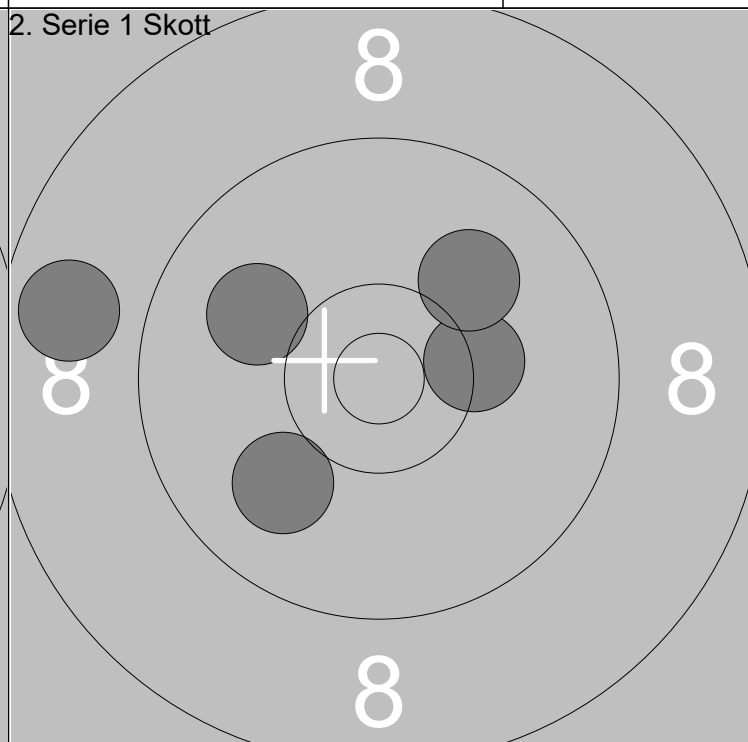
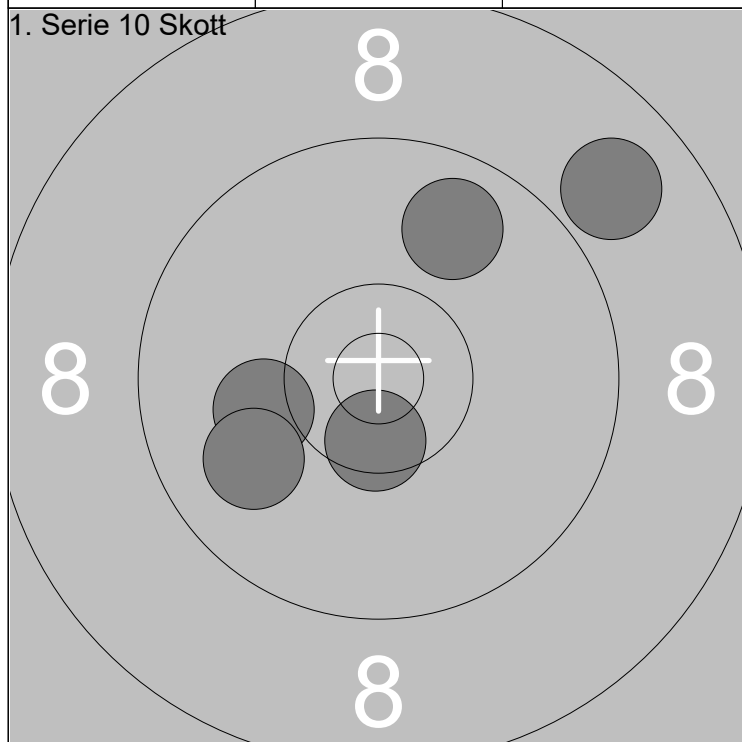

6: 8.9 ↗	Serie	46
7: 9.8 ↗		
8: 10.5x ↓	Total	283
9: 10.1 ←		
10: 9.9 ↖		

1: 8.8 ←	Serie	48
2: 10.0 ←		
3: 10.0 ↘	Total	331
4: 10.3 →		
5: 10.0 ↗		

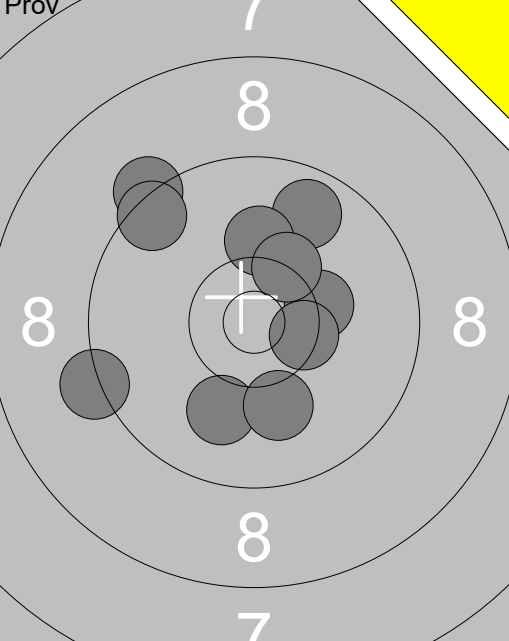
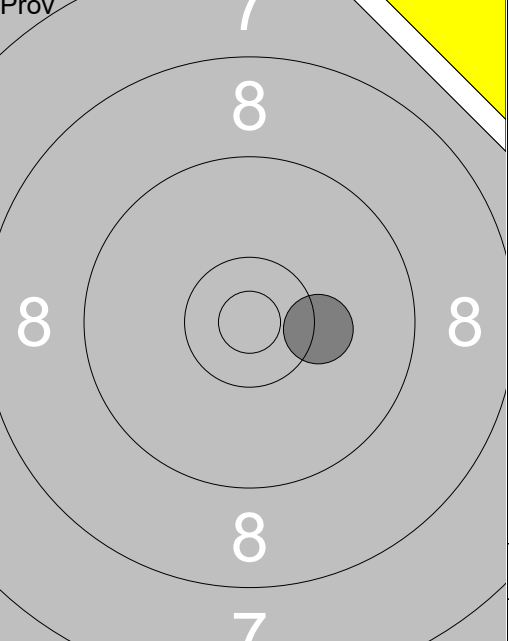
Prov 	1: 9.7 ↗ 2: 9.3 ↖ 3: 10.1 ↑ 4: 10.3 → 5: 10.0 ↓ 6: 10.1 ↓ 7: 10.4x → 8: 9.5 ↖ 9: 9.2 ← 10: 10.3x ↗	Prov 	11: 10.3 →
Serie 96.0		Serie 10.0	
Total 191.0		Total 191.0	

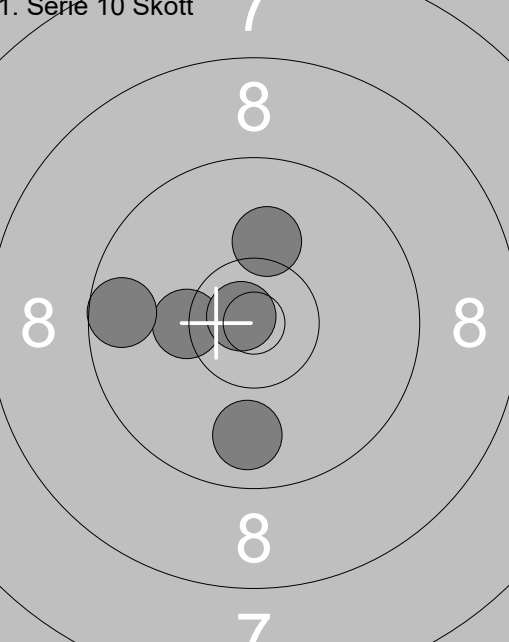
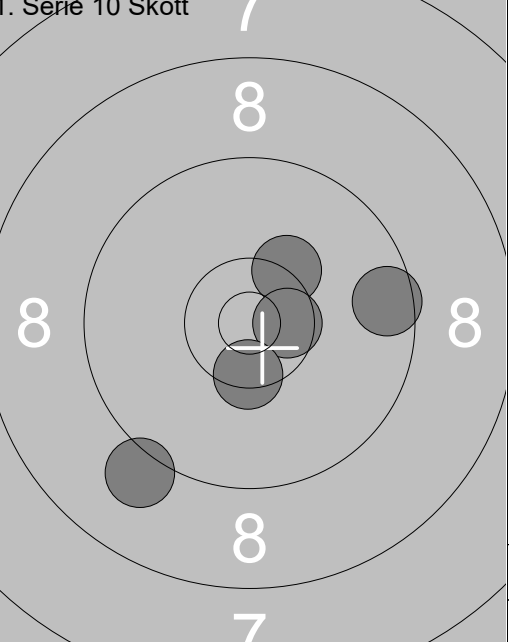
1. Serie 10 Skott 	1: 10.3 ← 2: 9.8 ↓ 3: 10.8x ↘ 4: 10.1 ↑ 5: 9.6 ←	1. Serie 10 Skott 	6: 10.3x ↗ 7: 9.6 → 8: 10.6x → 9: 10.4x ↓ 10: 9.1 ↘
Serie 48.0		Serie 48.0	
Total 239.0		Total 287.0	

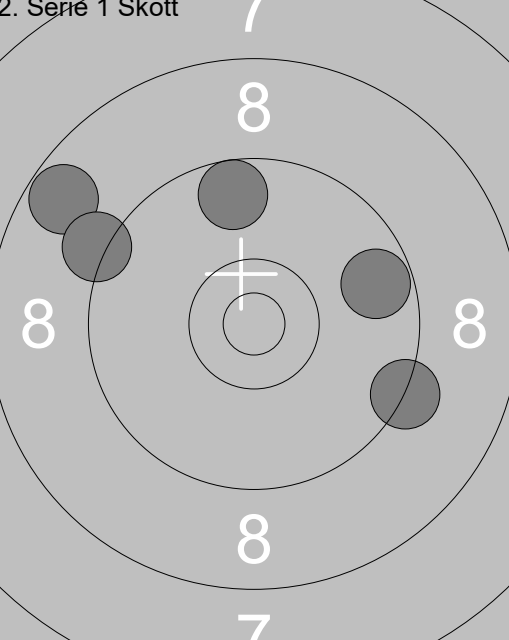
2. Serie 1 Skott 	1: 8.7 ↖ 2: 9.2 ↖ 3: 9.3 → 4: 9.7 → 5: 9.6 ↑		
Serie 44.0			
Total 331.0			

Skjutlag

5

Tavla

10

Maja Lindberg

Ramselefors

Ramselefors

Sen-L

Vb

09.07.2024

Tavelträffen Korthåll 2024

Ramselefors SKF

Prov

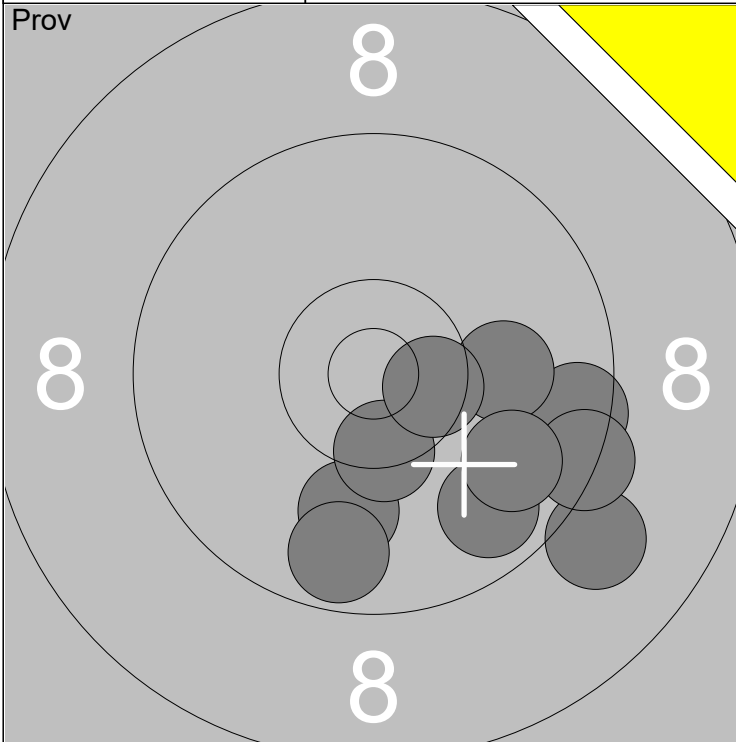

1. Serie 10 Skott

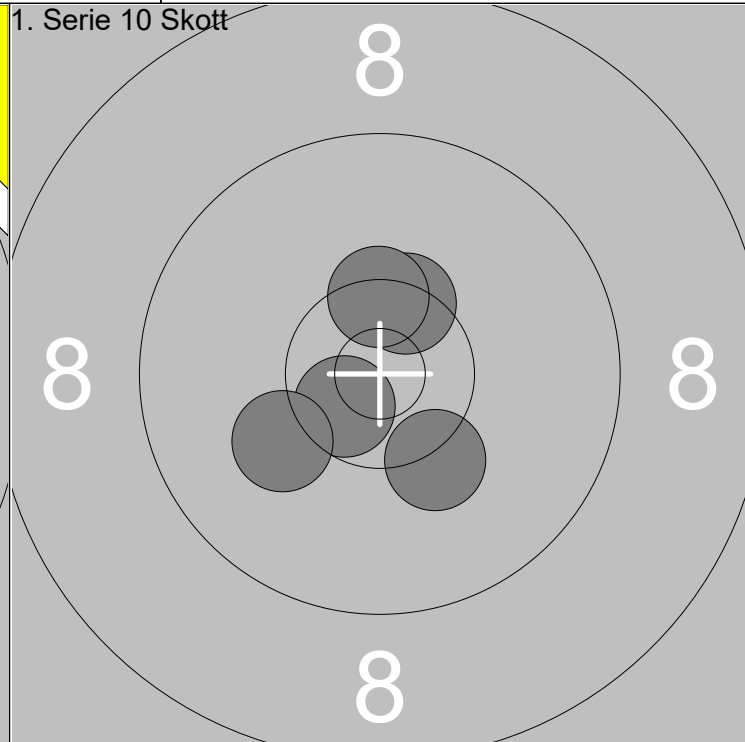

1: 9.0 ↘
2: 9.7 ↘
3: 9.5 →
4: 9.4 ↘
5: 10.0 ↓

6: 10.1 →
7: 10.4x ↓
8: 10.5x →
9: 9.7 ↓
10: 9.8 ↘

Serie	94
Total	190

1: 10.4x ↗
2: 10.6x ↙
3: 10.2 ↘
4: 10.1 ↙
5: 10.4x ↗

Serie	50
Total	240

1. Serie 10 Skott

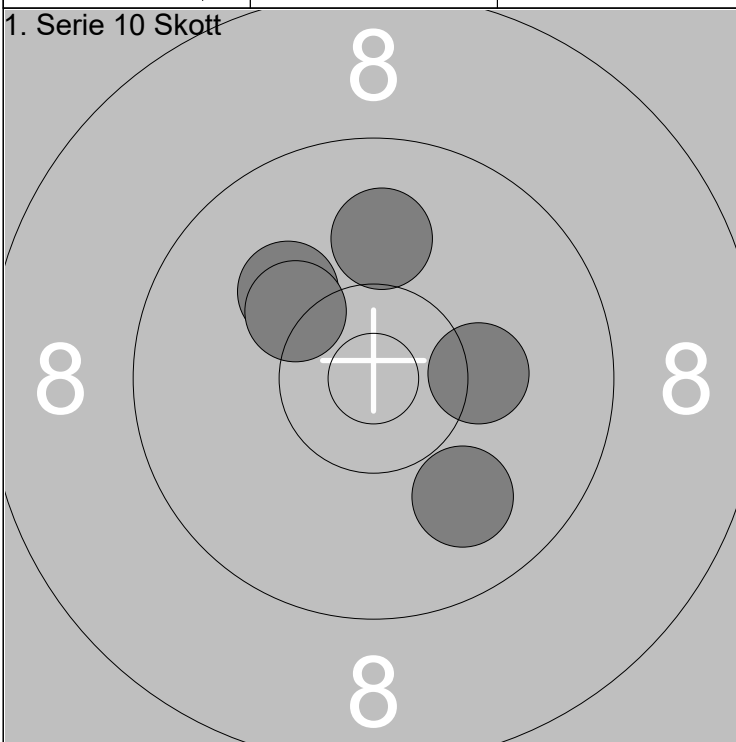

2. Serie 1 Skott

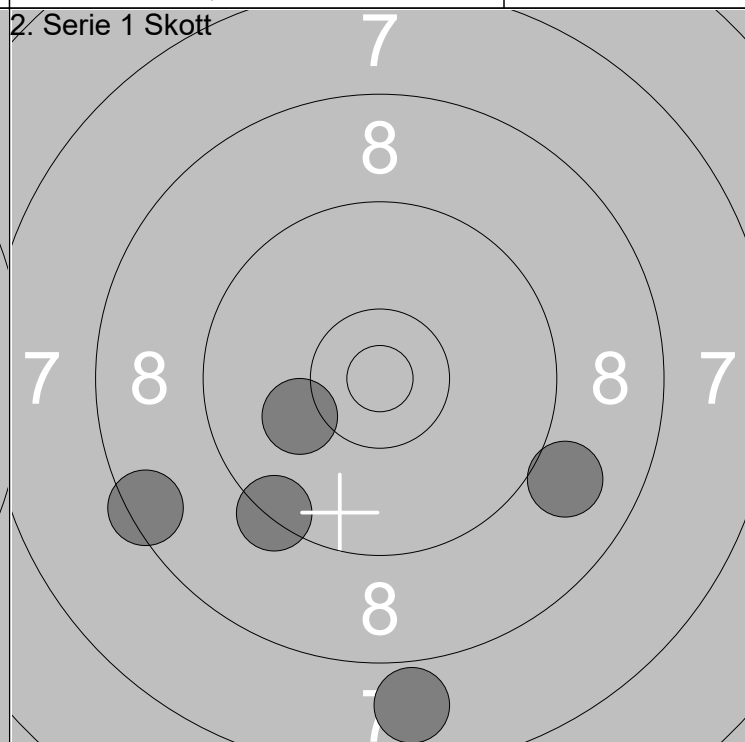

6: 10.1 ↗
7: 10.2 ↗
8: 9.9 ↘
9: 10.2 →
10: 10.0 ↗

Serie	49
Total	289

1: 8.5 ↙
2: 9.4 ↙
3: 9.0 →
4: 7.9 ↓
5: 10.1 ↙

Serie	43
Total	332

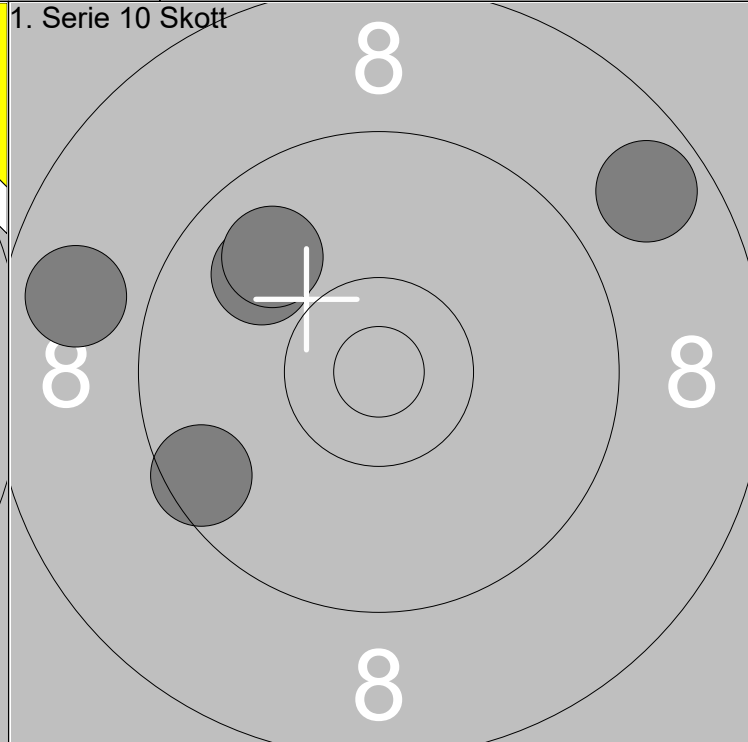
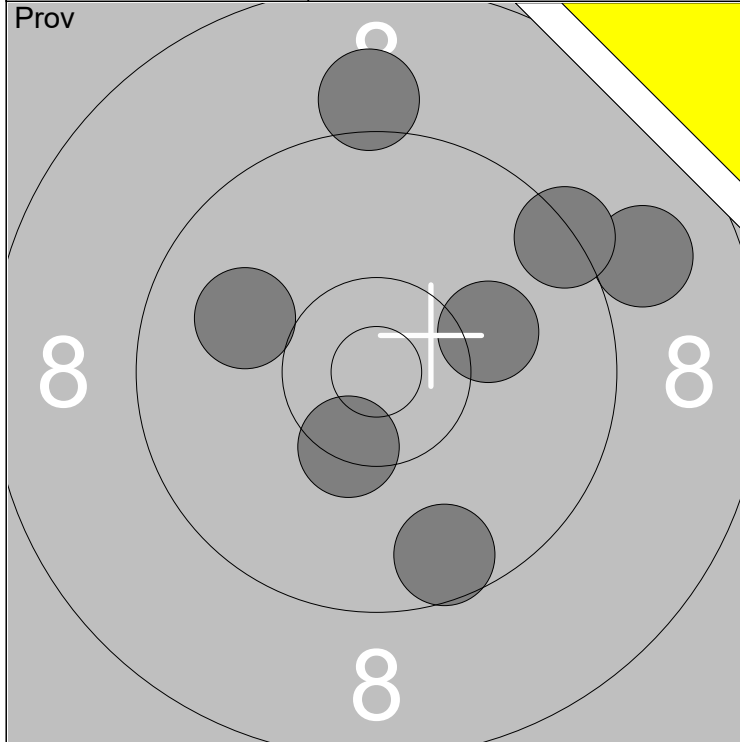

1: 10.1 →	6: 10.4x ↓	Serie	66
2: 9.6 ↓	7: 10.0 ←		
3: 9.0 →		Total	189
4: 9.1 ↑			
5: 9.4 ↗			

1: 8.8 ←	Serie	43
2: 9.9 ↗		
3: 9.5 ↙	Total	232
4: 8.7 ↗		
5: 9.9 ↙		

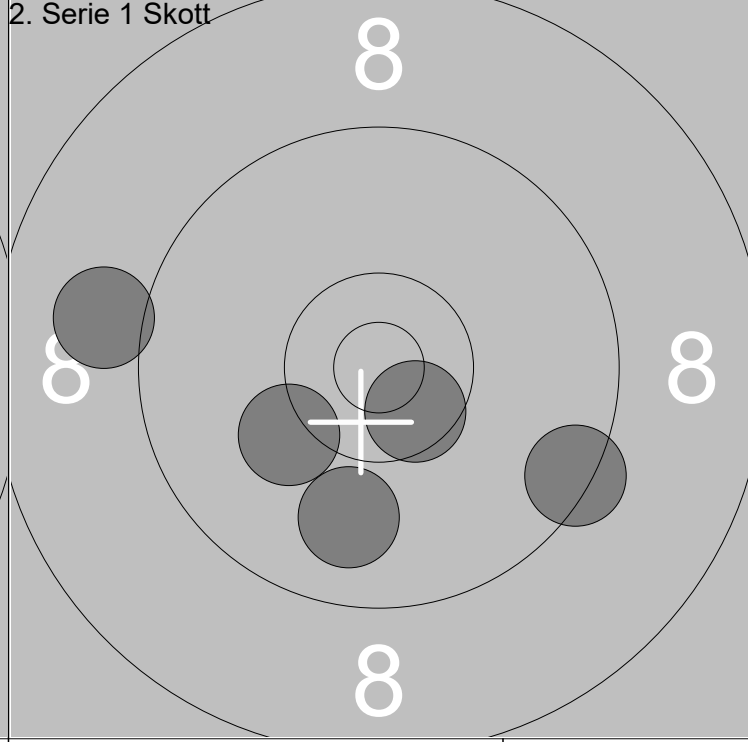
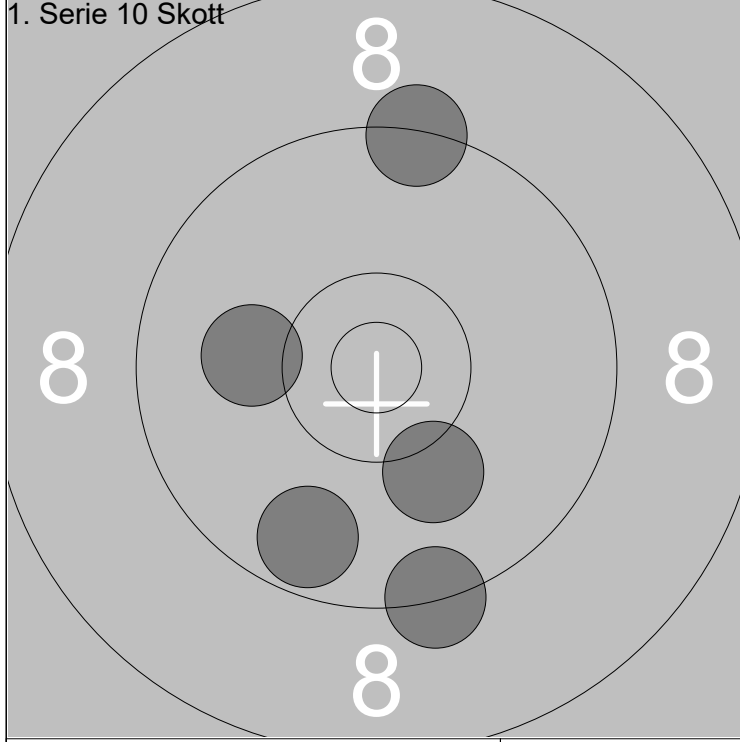

6: 9.3 ↑	Serie	47
7: 10.1 ←		
8: 10.1 ↓	Total	279
9: 9.7 ↓		
10: 9.3 ↓		

1: 9.0 ←	Serie	47
2: 10.6x ↓		
3: 9.4 ↘	Total	326
4: 9.9 ↓		
5: 10.2 ↙		

	<p>1: 9.3 ↑</p> <p>2: 9.1 ↑</p> <p>3: 10.6 ↗</p> <p>4: 10.2 →</p> <p>5: 10.1 ↘</p> <p>6: 10.5 ↘</p> <p>7: 10.4 ↘</p> <p>8: 10.2 ↙</p> <p>9: 10.5 ↘</p> <p>10: 9.2 ↓</p>		<p>11: 9.8 ↓</p> <p>12: 10.1 ↓</p>
Serie 97.0		Serie 19.0	
Total 186.0		Total 186.0	

<p>1. Serie 10 Skott</p>	<p>1: 10.3 ↘</p> <p>2: 10.0 ↓</p> <p>3: 8.2 →</p> <p>4: 10.3 ↘</p> <p>5: 10.2 ↙</p>	<p>1. Serie 10 Skott</p>	<p>6: 10.5 ↗</p> <p>7: 9.7 ↑</p> <p>8: 10.9 ↗</p> <p>9: 9.5 ↗</p> <p>10: 9.8 ↘</p>
Serie 48.0		Serie 47.0	
Total 234.0		Total 281.0	

<p>2. Serie 1 Skott</p>	<p>1: 10.1 ↑</p> <p>2: 10.5 ↗</p> <p>3: 7.7 ↑</p> <p>4: 9.2 ↙</p> <p>5: 10.2 ↓</p>		
Serie 46.0			
Total 327.0			

	<p>1: 9.4 →</p> <p>2: 7.8 ↗</p> <p>3: 8.7 ↗</p> <p>4: 10.7x→</p> <p>5: 8.8 ↗</p> <p>6: 9.6 →</p> <p>7: 8.9 ←</p> <p>8: 9.2 ↘</p> <p>9: 10.3x→</p> <p>10: 8.1 ↗</p>	<p>11: 10.0←</p> <p>12: 9.9 ↗</p>
Serie 86.0		Serie 19.0
Total 183.0		Total 183.0

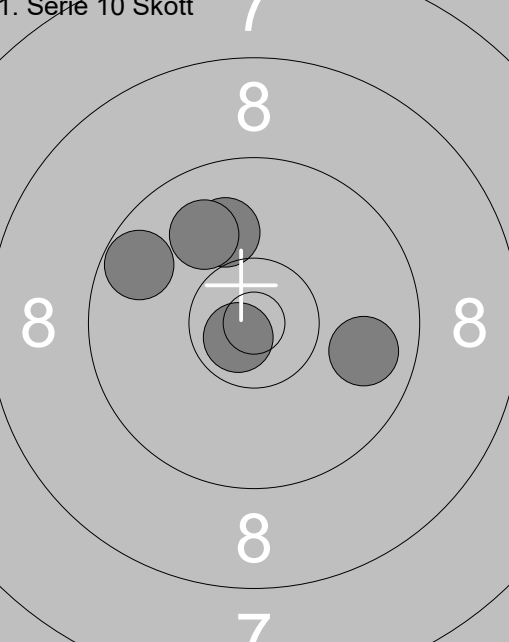
<p>1. Serie 10 Skott</p> 	<p>1: 9.8 →</p> <p>2: 10.0 ↗</p> <p>3: 10.7x↘</p> <p>4: 9.9 ↗</p> <p>5: 9.7 ←</p>	<p>6: 8.6 ↗</p> <p>7: 9.6 →</p> <p>8: 9.3 →</p> <p>9: 9.4 →</p> <p>10: 10.0 ↗</p>
Serie 47.0		Serie 45.0
Total 230.0		Total 275.0

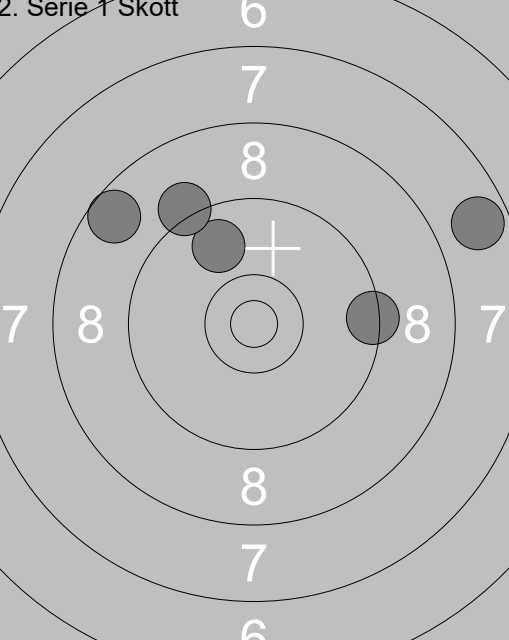
<p>2. Serie 1 Skott</p> 	<p>1: 8.6 ↖</p> <p>2: 9.8 ↗</p> <p>3: 9.4 →</p> <p>4: 7.7 ↗</p> <p>5: 9.2 ↗</p>	
Serie 42.0		
Total 317.0		

<p>Prov</p>	<p>1: 10.5x ↘ 2: 9.7 ↖ 3: 10.0 ↓ 4: 10.4x ↓ 5: 9.4 ↓ 6: 7.7 ↓ 7: 10.1 ← 8: 9.3 → 9: 9.6 ↗ 10: 8.7 →</p>	<p>Prov</p>	<p>11: 9.0 → 12: 10.4x ↗ 13: 9.7 ↓ 14: 9.7 → 15: 9.7 ↖</p>
Serie 91.0		Serie 46.0	
Total 183.0		Total 183.0	

<p>1. Serie 10 Skott</p>	<p>1: 10.5x ↘ 2: 10.0 ↗ 3: 9.9 ↓ 4: 7.6 → 5: 9.2 →</p>	<p>1. Serie 10 Skott</p>	<p>6: 10.0 ↖ 7: 8.2 ↖ 8: 9.5 ↗ 9: 10.7x → 10: 10.2 ↗</p>
Serie 45.0		Serie 47.0	
Total 228.0		Total 275.0	

<p>2. Serie 1 Skott</p>	<p>1: 8.9 ↖ 2: 10.1 ← 3: 8.5 → 4: 9.7 ↑ 5: 10.1 ↓</p>		
Serie 45.0			
Total 320.0			

	<p>1: 10.8x ↘</p> <p>2: 9.5 ↓</p> <p>3: 8.4 ↘</p> <p>4: 8.9 ↘</p> <p>5: 9.9 ↗</p> <p>6: 9.8 →</p> <p>7: 9.4 ↓</p> <p>8: 10.2 ↖</p> <p>9: 9.4 ↓</p> <p>10: 9.7 ↗</p>		<p>11: 9.8 ↑</p> <p>12: 9.6 ↑</p>								
<table style="width:100%; border-collapse: collapse;"> <tr> <td style="border-right: 1px solid black;">Serie</td> <td style="text-align: right;">90.0</td> </tr> <tr> <td style="border-right: 1px solid black;">Total</td> <td style="text-align: right;">181.0</td> </tr> </table>		Serie	90.0	Total	181.0	<table style="width:100%; border-collapse: collapse;"> <tr> <td style="border-right: 1px solid black;">Serie</td> <td style="text-align: right;">18.0</td> </tr> <tr> <td style="border-right: 1px solid black;">Total</td> <td style="text-align: right;">181.0</td> </tr> </table>		Serie	18.0	Total	181.0
Serie	90.0										
Total	181.0										
Serie	18.0										
Total	181.0										

<p>1. Serie 10 Skott</p>	<p>1: 8.9 ↖</p> <p>2: 9.7 →</p> <p>3: 10.6x ↗</p> <p>4: 10.4x ↖</p> <p>5: 10.3x ↘</p>		<p>6: 9.9 ↑</p> <p>7: 9.7 ↘</p> <p>8: 9.4 →</p> <p>9: 9.4 ↖</p> <p>10: 10.1 ↗</p>								
<table style="width:100%; border-collapse: collapse;"> <tr> <td style="border-right: 1px solid black;">Serie</td> <td style="text-align: right;">47.0</td> </tr> <tr> <td style="border-right: 1px solid black;">Total</td> <td style="text-align: right;">228.0</td> </tr> </table>		Serie	47.0	Total	228.0	<table style="width:100%; border-collapse: collapse;"> <tr> <td style="border-right: 1px solid black;">Serie</td> <td style="text-align: right;">46.0</td> </tr> <tr> <td style="border-right: 1px solid black;">Total</td> <td style="text-align: right;">274.0</td> </tr> </table>		Serie	46.0	Total	274.0
Serie	47.0										
Total	228.0										
Serie	46.0										
Total	274.0										

<p>2. Serie 1 Skott</p>	<p>1: 6.1 ←</p> <p>2: 8.6 ←</p> <p>3: 9.9 ←</p> <p>4: 9.2 →</p> <p>5: 10.6x ↘</p>						
<table style="width:100%; border-collapse: collapse;"> <tr> <td style="border-right: 1px solid black;">Serie</td> <td style="text-align: right;">42.0</td> </tr> <tr> <td style="border-right: 1px solid black;">Total</td> <td style="text-align: right;">316.0</td> </tr> </table>		Serie	42.0	Total	316.0		
Serie	42.0						
Total	316.0						

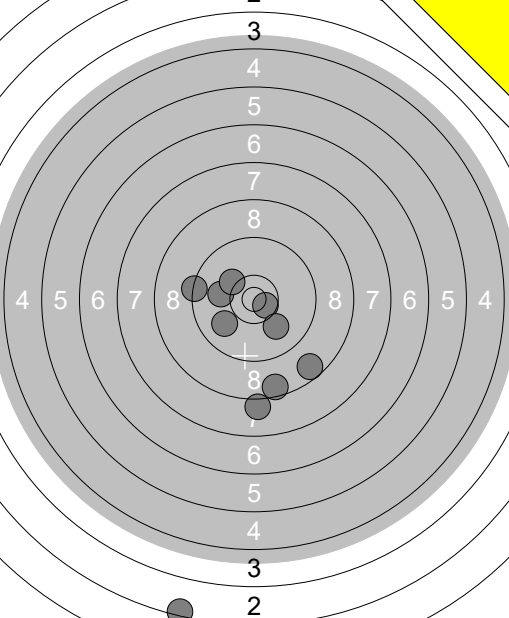
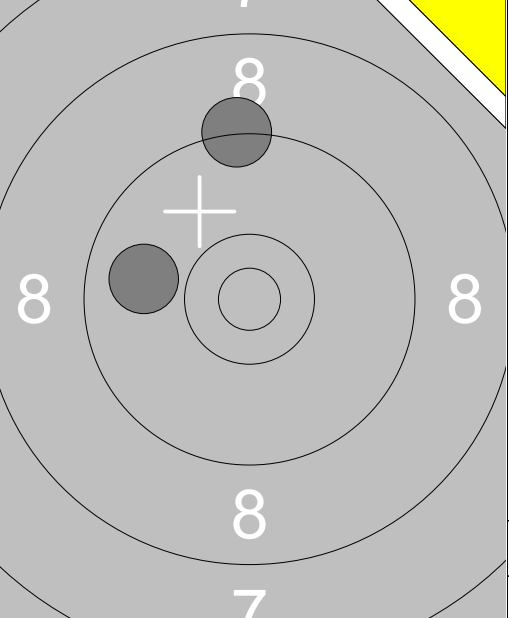
Prov	Prov	
		11: 9.3 ↑ 12: 9.9 ←
1: 2.4 ↓ 2: 8.5 ↓ 3: 9.3 ← 4: 8.1 ↓ 5: 8.6 ↓ 6: 10.6x → 7: 10.0 ← 8: 10.0 ↓ 9: 10.2 ↖ 10: 9.9 ↙	1: 9.3 ↓ 2: 8.5 ↓ 3: 9.3 ← 4: 8.1 ↓ 5: 8.6 ↓ 6: 10.6x → 7: 10.0 ← 8: 10.0 ↓ 9: 10.2 ↖ 10: 9.9 ↙	Serie 84.0 Total 177.0
Serie 84.0 Total 177.0	Serie 18.0 Total 177.0	

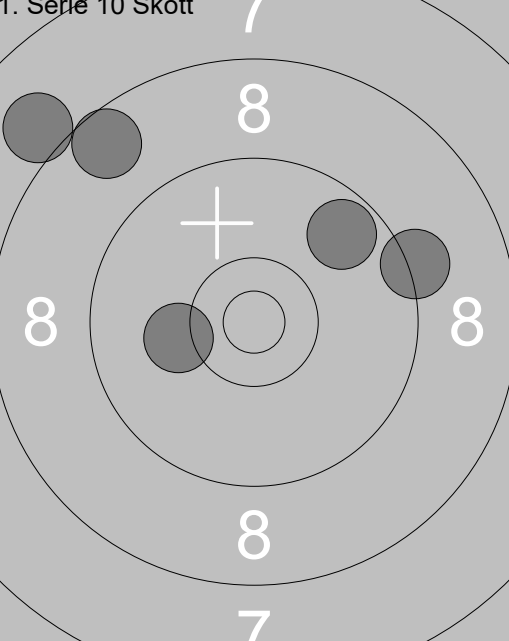
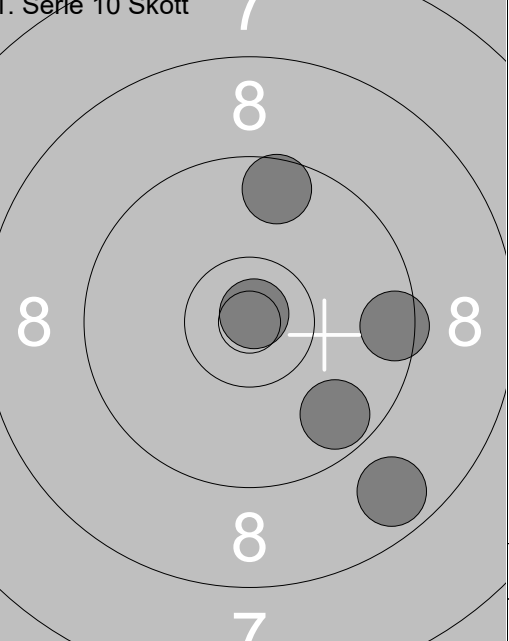
1. Serie 10 Skott	1. Serie 10 Skott	
		6: 8.7 ↓ 7: 10.9x ↗ 8: 9.7 ↓ 9: 9.5 → 10: 9.6 ↑
1: 9.2 → 2: 9.7 ↗ 3: 8.6 ↗ 4: 8.0 ↗ 5: 10.2 ←	1: 9.2 → 2: 9.7 ↗ 3: 8.6 ↗ 4: 8.0 ↗ 5: 10.2 ←	Serie 44.0 Total 221.0
Serie 44.0 Total 221.0	Serie 45.0 Total 266.0	

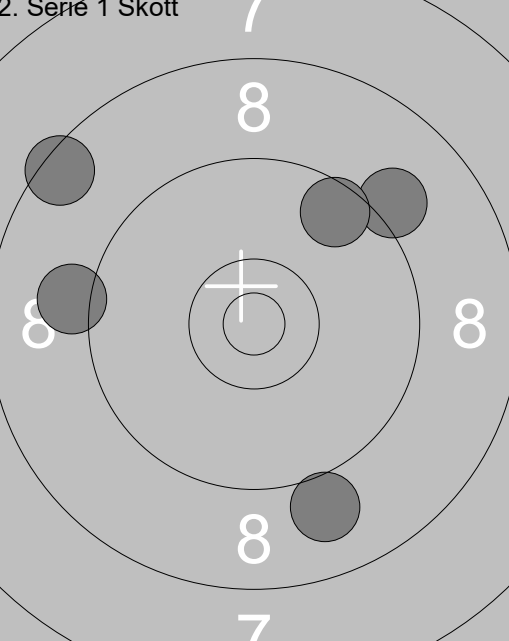
2. Serie 1 Skott		
		
1: 8.5 ↖ 2: 9.1 ← 3: 9.0 ↓ 4: 9.1 ↗ 5: 9.6 ↗		Serie 44.0 Total 310.0
Serie 44.0 Total 310.0		

	<p>1: 9.3 ↗</p> <p>2: 9.7 ↑</p> <p>3: 10.3 →</p> <p>4: 8.8 ↑</p> <p>5: 9.4 ↘</p> <p>6: 9.0 ↑</p> <p>7: 8.6 ↗</p> <p>8: 8.0 →</p> <p>9: 6.9 ↘</p> <p>10: 8.8 ↘</p>		<p>11: 10.1 ↖</p> <p>12: 9.7 ↑</p> <p>13: 9.4 ↘</p>								
<table style="width:100%; border-collapse: collapse;"> <tr> <td style="border-right: 1px solid black;">Serie</td> <td style="text-align: right;">84.0</td> </tr> <tr> <td style="border-right: 1px solid black;">Total</td> <td style="text-align: right;">175.0</td> </tr> </table>		Serie	84.0	Total	175.0	<table style="width:100%; border-collapse: collapse;"> <tr> <td style="border-right: 1px solid black;">Serie</td> <td style="text-align: right;">28.0</td> </tr> <tr> <td style="border-right: 1px solid black;">Total</td> <td style="text-align: right;">175.0</td> </tr> </table>		Serie	28.0	Total	175.0
Serie	84.0										
Total	175.0										
Serie	28.0										
Total	175.0										

<p>1. Serie 10 Skott</p>	<p>1: 9.7 ↓</p> <p>2: 8.7 ↖</p> <p>3: 10.1 ↘</p> <p>4: 9.0 ←</p> <p>5: 9.4 →</p>		<p>6: 8.1 ↖</p> <p>7: 9.0 ↘</p> <p>8: 10.5 ↖</p> <p>9: 8.7 ↗</p> <p>10: 9.7 →</p>								
<table style="width:100%; border-collapse: collapse;"> <tr> <td style="border-right: 1px solid black;">Serie</td> <td style="text-align: right;">45.0</td> </tr> <tr> <td style="border-right: 1px solid black;">Total</td> <td style="text-align: right;">220.0</td> </tr> </table>		Serie	45.0	Total	220.0	<table style="width:100%; border-collapse: collapse;"> <tr> <td style="border-right: 1px solid black;">Serie</td> <td style="text-align: right;">44.0</td> </tr> <tr> <td style="border-right: 1px solid black;">Total</td> <td style="text-align: right;">264.0</td> </tr> </table>		Serie	44.0	Total	264.0
Serie	45.0										
Total	220.0										
Serie	44.0										
Total	264.0										

<p>2. Serie 1 Skott</p>	<p>1: 10.3 ↖</p> <p>2: 9.8 ↖</p> <p>3: 8.6 ↓</p> <p>4: 9.1 ↑</p> <p>5: 10.3 ↖</p>						
<table style="width:100%; border-collapse: collapse;"> <tr> <td style="border-right: 1px solid black;">Serie</td> <td style="text-align: right;">46.0</td> </tr> <tr> <td style="border-right: 1px solid black;">Total</td> <td style="text-align: right;">310.0</td> </tr> </table>		Serie	46.0	Total	310.0		
Serie	46.0						
Total	310.0						

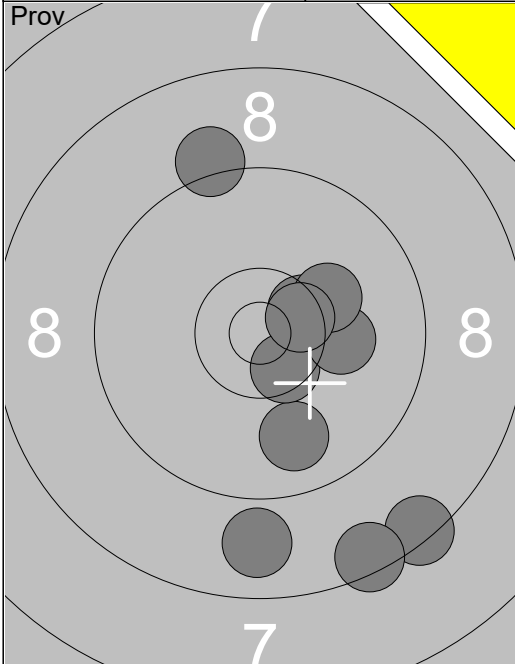

1:	8.4	↘
2:	9.9	↘
3:	10.5x	↘
4:	10.1	→
5:	8.9	↘
6:	8.5	↘
7:	10.5x	↗
8:	10.2	↗
9:	9.2	↑
10:	10.5x	↗
Serie		92.0
Total		194.0

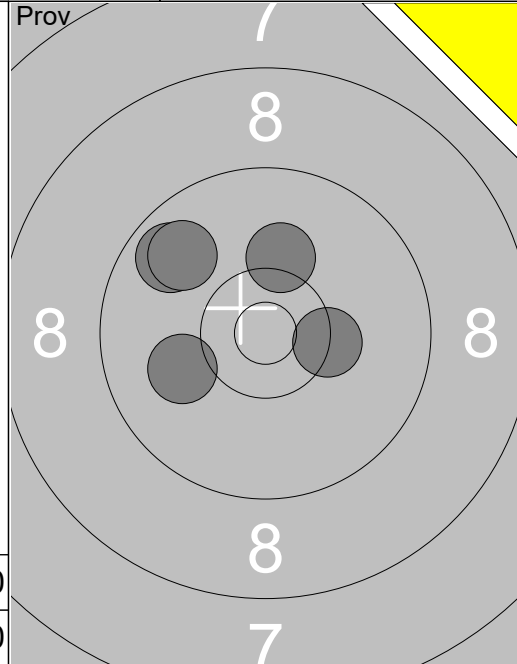

11:	10.2	↑
12:	10.3x	→
13:	9.7	↖
14:	10.0	↖
15:	9.8	↖
Serie		48.0
Total		194.0

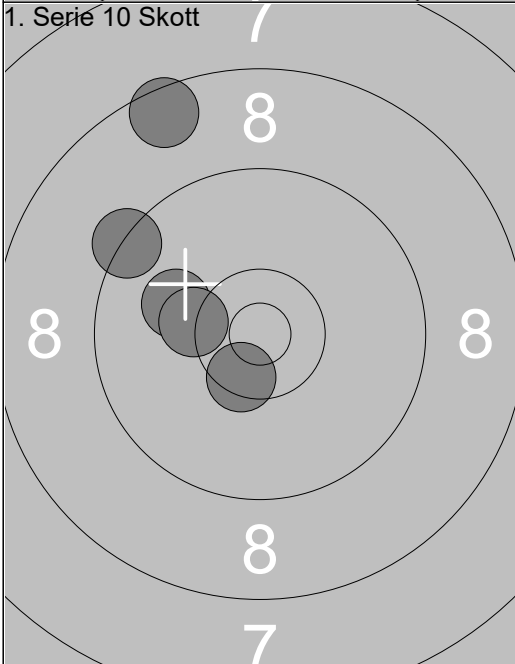

1:	8.5	↑
2:	9.3	↖
3:	10.1	↖
4:	10.3	↖
5:	10.5x	↘
Serie		47.0
Total		241.0

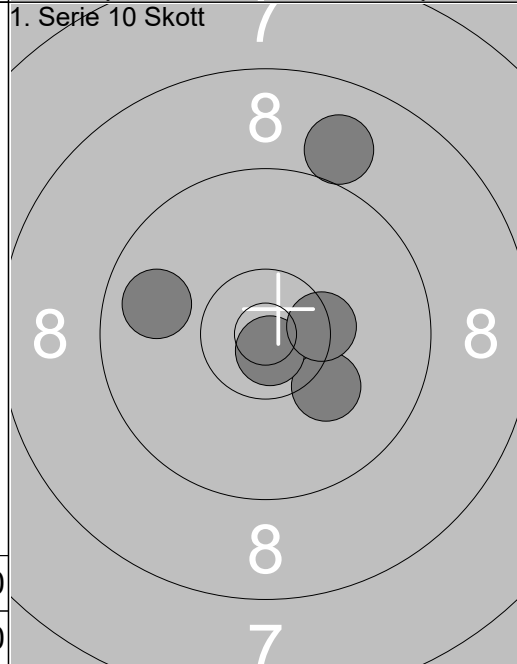

6:	9.0	↑
7:	10.2	↘
8:	10.8x	↘
9:	9.8	↖
10:	10.4x	→
Serie		48.0
Total		289.0

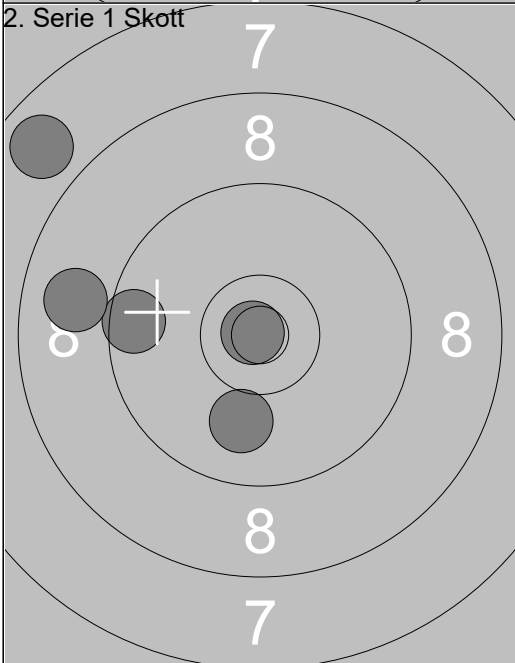

1:	7.8	↖
2:	9.6	↖
3:	10.9x	↖
4:	10.0	↘
5:	8.9	↖
Serie		44.0
Total		333.0

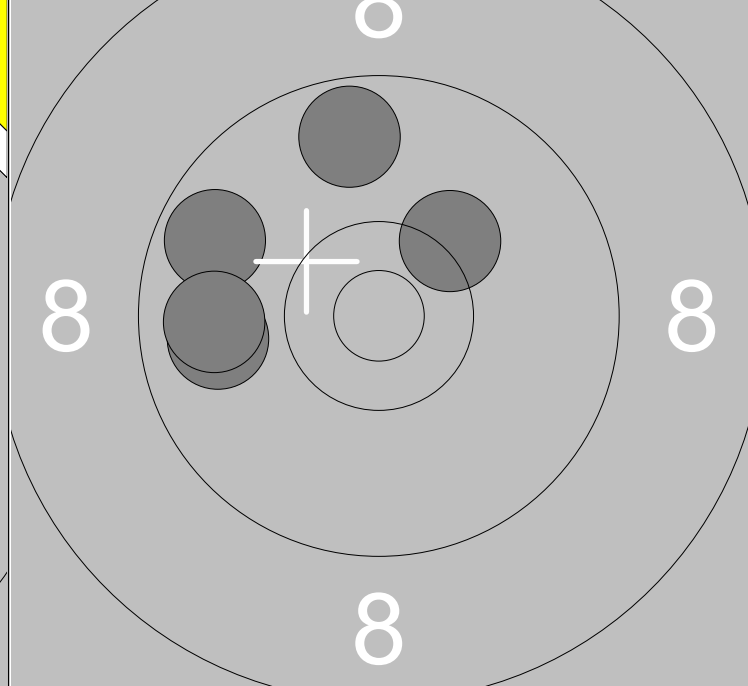
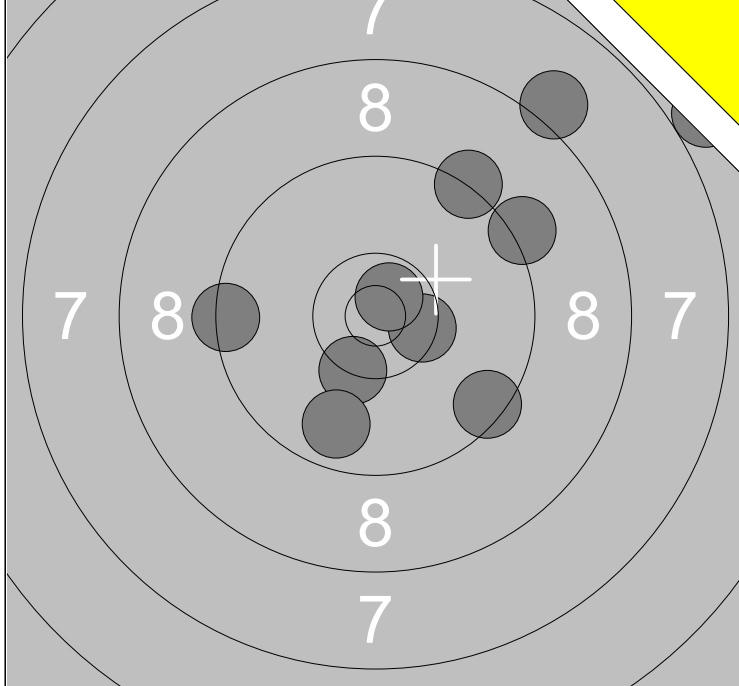

1: 9.3 ↗	6: 9.8 ↓	Serie	89
2: 8.1 ↗	7: 9.5 ↘		
3: 6.9 ↗	8: 9.2 ↗	Total	192
4: 10.3x ↓	9: 9.4 ←		
5: 10.4x →	10: 10.7x ↗		

1: 9.7 ↖	Serie	46
2: 9.8 ←		
3: 10.2 ↗	Total	238
4: 9.7 ↑		
5: 9.8 ←		

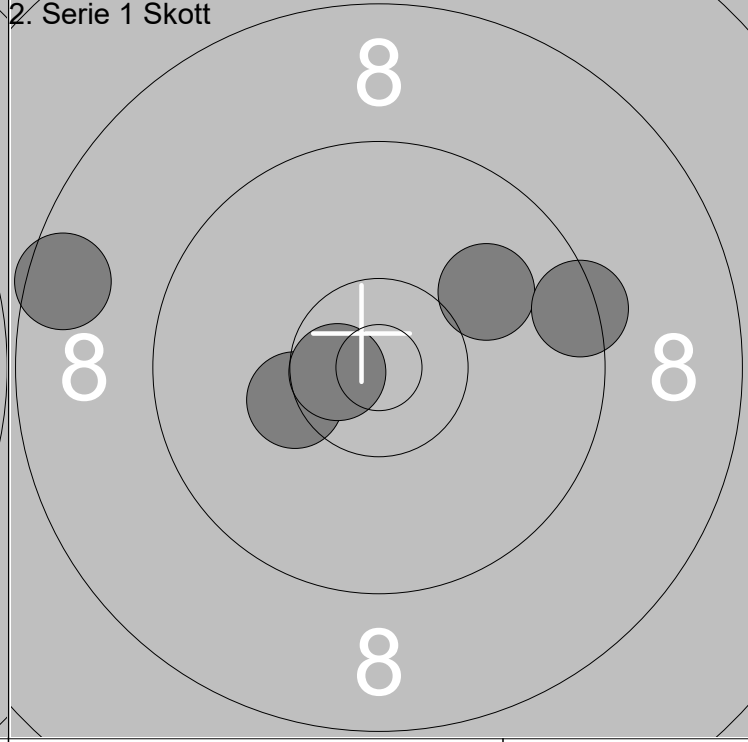
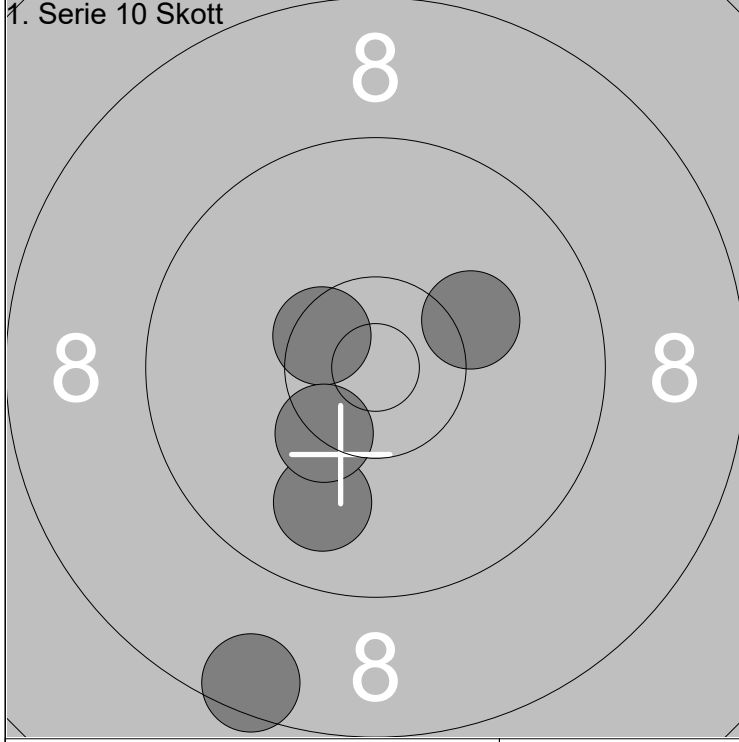

6: 8.5 ↓	Serie	47
7: 10.5x ↖		
8: 9.9 ↓	Total	285
9: 10.2 ↗		
10: 10.4x ↓		

1: 8.6 ↖	Serie	47
2: 10.3x ↖		
3: 10.0 ↗	Total	332
4: 9.4 →		
5: 10.6x ←		

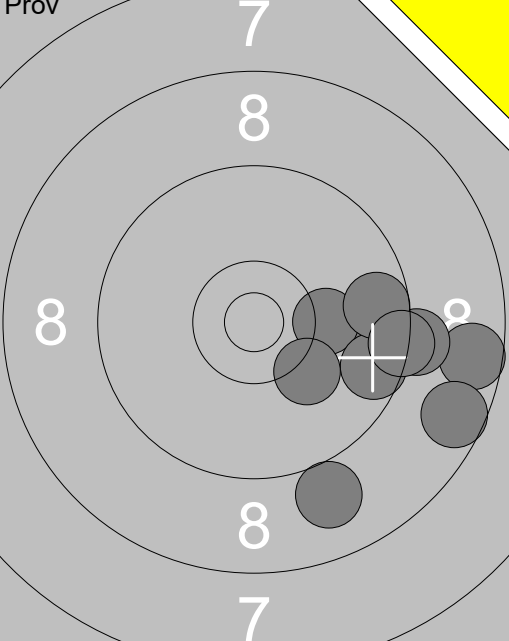
	<p>1: 8.6 →</p> <p>2: 9.7 →</p> <p>3: 10.2 →</p> <p>4: 9.2 →</p> <p>5: 8.6 →</p> <p>6: 9.6 →</p> <p>7: 9.6 →</p> <p>8: 9.0 ↓</p> <p>9: 9.4 →</p> <p>10: 10.2 ↓</p>	<p>Prov</p>  <p>11: 10.7x ↗</p> <p>12: 10.0 ↙</p> <p>13: 10.2 ↘</p> <p>14: 10.5x ↘</p>
Serie 90.0		Serie 40.0
Total 186.0		Total 186.0

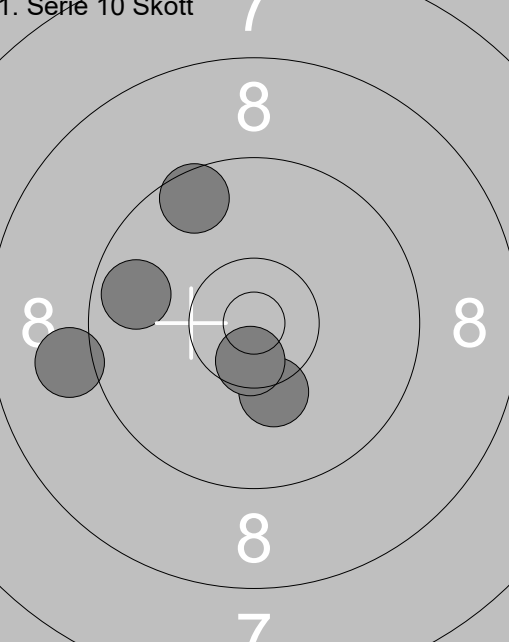
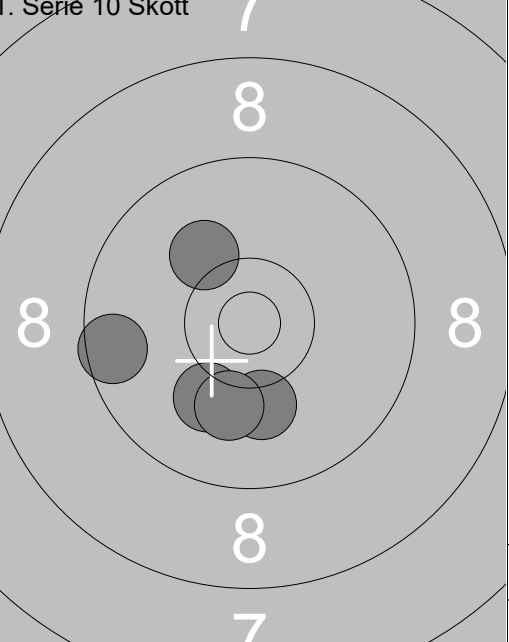
<p>1. Serie 10 Skott</p> 	<p>1: 9.6 ↗</p> <p>2: 10.2 ↓</p> <p>3: 10.6x ↓</p> <p>4: 9.7 ←</p> <p>5: 9.1 ←</p>	<p>1. Serie 10 Skott</p>  <p>6: 10.1 ↓</p> <p>7: 10.1 ↓</p> <p>8: 10.1 ↓</p> <p>9: 10.1 ↗</p> <p>10: 9.6 ←</p>
Serie 47.0		Serie 49.0
Total 233.0		Total 282.0

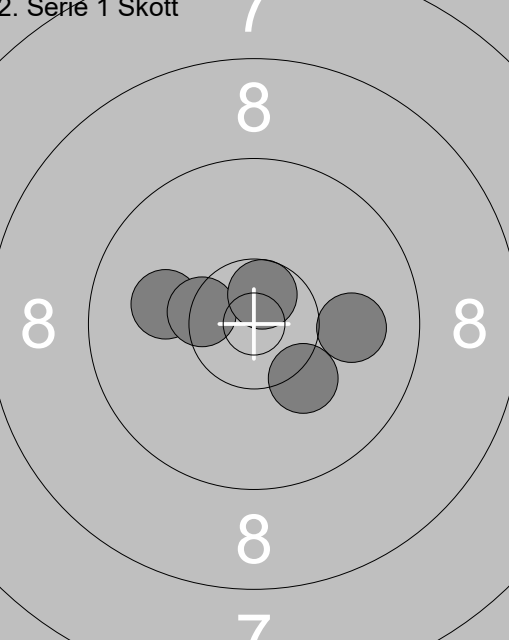
<p>2. Serie 1 Skott</p> 	<p>1: 10.0 ←</p> <p>2: 10.4x ←</p> <p>3: 10.2 ↓</p> <p>4: 10.0 →</p> <p>5: 10.6x ↗</p>	
Serie 50.0		
Total 332.0		

	<p>1: 10.4x ➤</p> <p>2: 6.2 →</p> <p>3: 7.7 ➤</p> <p>4: 8.3 ↗</p> <p>5: 10.4x ➤</p> <p>6: 8.2 ↗</p> <p>7: 9.2 ➤</p> <p>8: 9.8 ↗</p> <p>10: 10.5x ➤</p>		<p>11: 9.9 ↗</p> <p>12: 9.0 ↖</p> <p>13: 9.6 ↓</p> <p>14: 9.0 ←</p> <p>15: 9.8 ➤</p> <p>16: 10.1 ↑</p> <p>17: 6.4 ↖</p>
Serie 77.0		Serie 61.0	
Total 186.0		Total 186.0	

<p>1. Serie 10 Skott</p>	<p>1: 9.9 ↖</p> <p>2: 10.4x ✓</p> <p>3: 8.8 ↘</p> <p>4: 8.3 ↘</p> <p>5: 8.3 ↖</p>		<p>6: 9.3 ↖</p> <p>7: 9.2 ↖</p> <p>8: 10.0 ↓</p> <p>9: 9.7 ➤</p> <p>10: 9.7 ←</p>
Serie 43.0		Serie 46.0	
Total 229.0		Total 275.0	

<p>2. Serie 1 Skott</p>	<p>1: 9.0 ←</p> <p>2: 10.5x ✗</p> <p>3: 8.3 ↘</p> <p>4: 10.7x ↗</p> <p>5: 9.6 ↓</p>		
Serie 46.0			
Total 321.0			

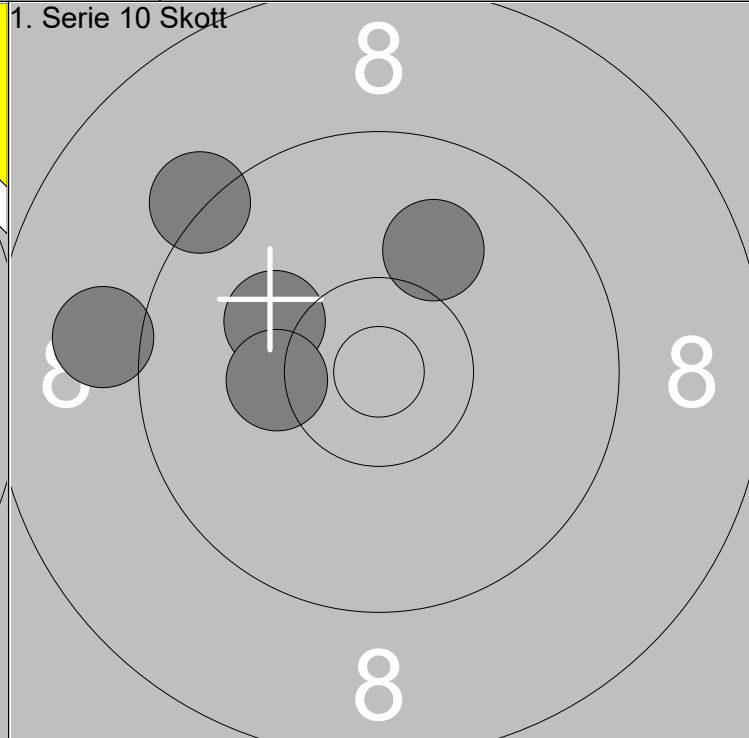
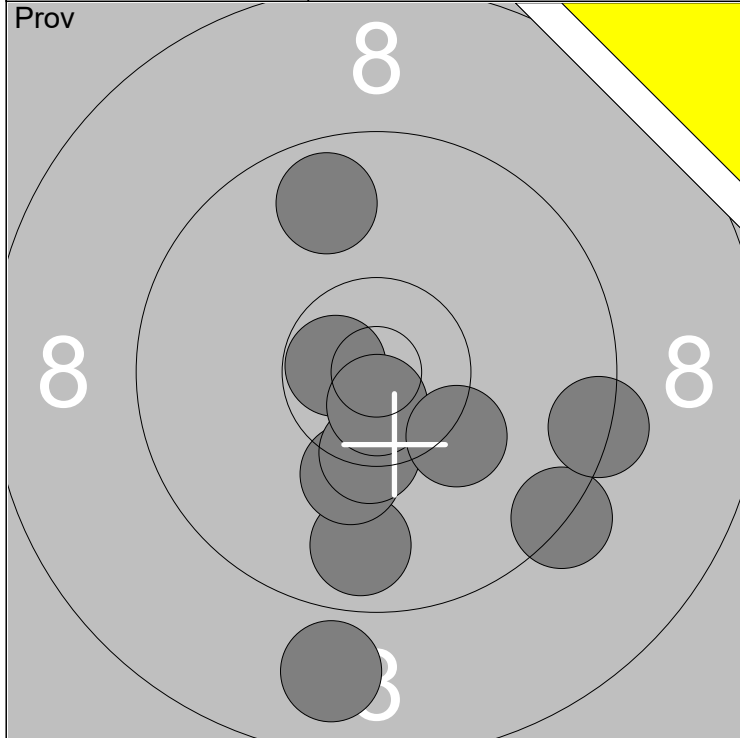

1: 8.9 ↓	6: 10.4x ↓		
2: 9.8 ↓	7: 10.7x ←		
3: 9.3 ↘	8: 9.4 →	Serie	94
4: 9.7 ↑	9: 10.7x ↓	Total	185
5: 10.2 ↓	10: 10.2 ↘		

1: 10.0 ↗			
2: 9.0 ←			
3: 10.2 ↖	Serie	48	Total
4: 10.2 ←			
5: 9.3 ↖			

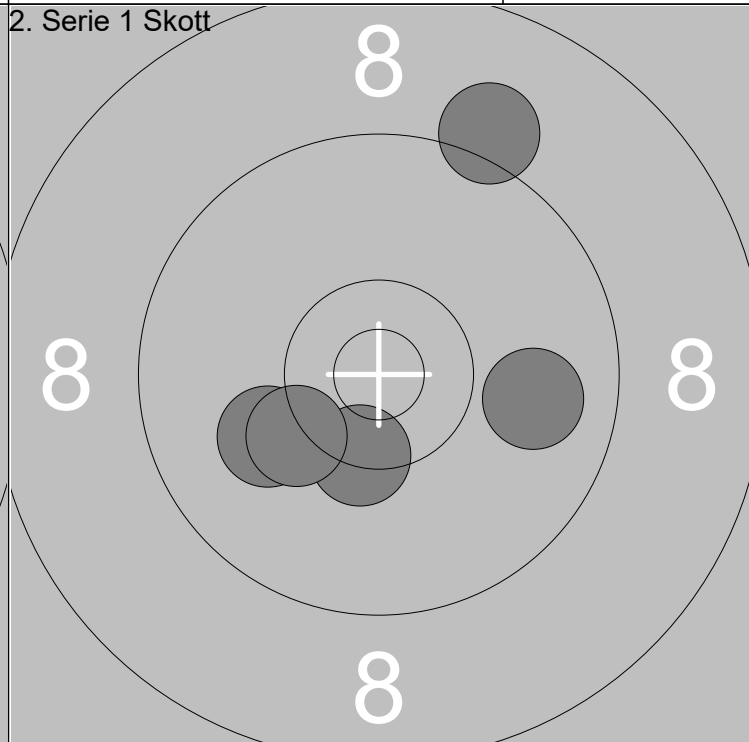
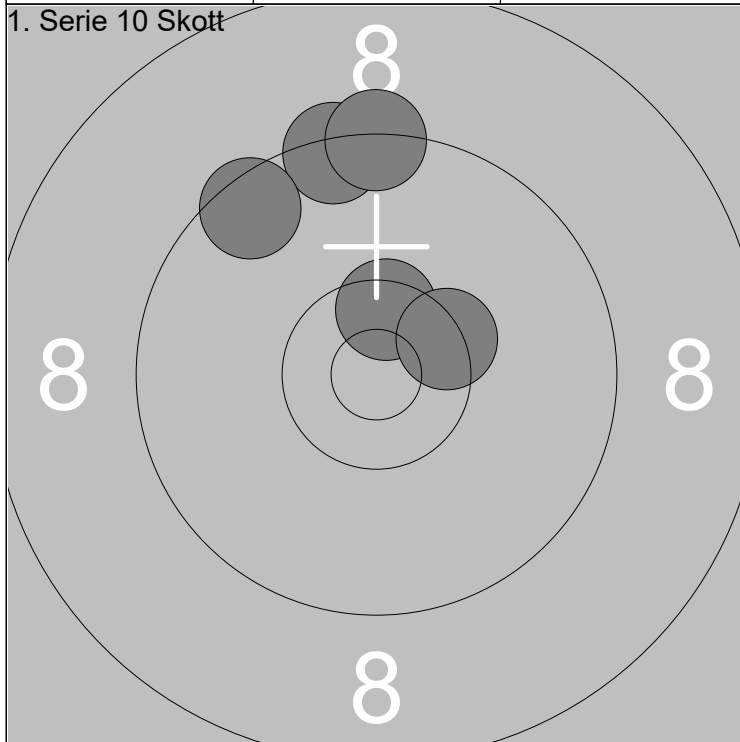

6: 10.5x ↑			
7: 9.4 ↑			
8: 9.3 ↑	Serie	47	Total
9: 10.4x ↗			
10: 9.5 ↖			

1: 10.4x ↓			
2: 10.1 ←			
3: 10.2 ↖	Serie	48	Total
4: 9.9 →			
5: 9.1 ↗			

	<p>1: 9.5 ↘ 2: 8.0 ↘ 3: 9.8 ↓ 4: 10.2 ↘ 5: 9.6 ↘ 6: 9.2 → 7: 9.5 → 8: 8.6 → 9: 10.7x→ 10: 9.4 ↙</p>	
Serie 90.0		Serie 51.0
Total 185.0		Total 185.0

<p>1. Serie 10 Skott</p>	<p>1: 7.6 ↑ 2: 8.9 ↑ 3: 10.4x↘ 4: 9.7 ↙ 5: 9.8 ↙</p>	<p>1. Serie 10 Skott</p>
Serie 43.0		Serie 49.0
Total 228.0		Total 277.0

<p>2. Serie 1 Skott</p>	<p>1: 8.4 ↙ 2: 8.9 ↑ 3: 9.7 ↗ 4: 9.3 → 5: 9.1 ↙</p>	
Serie 43.0		
Total 320.0		

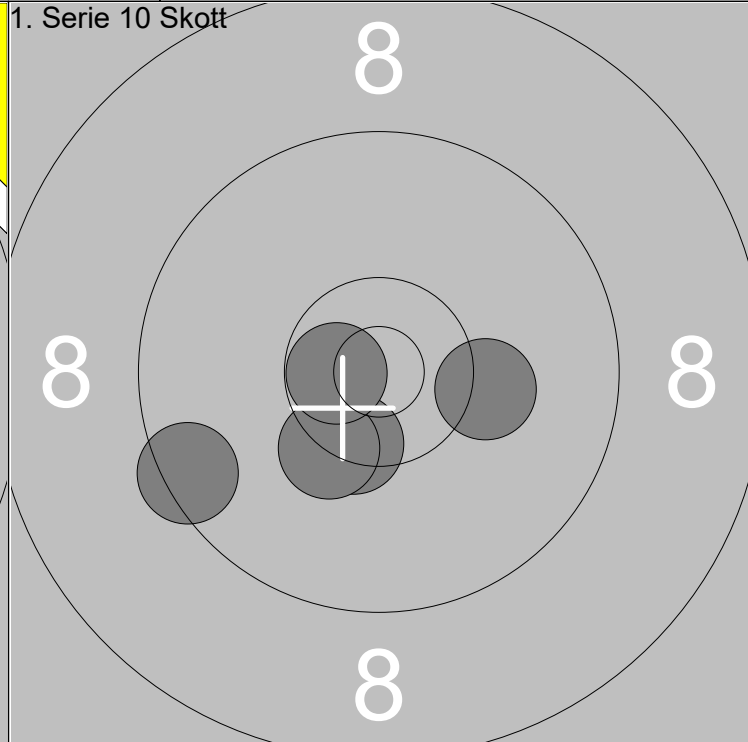
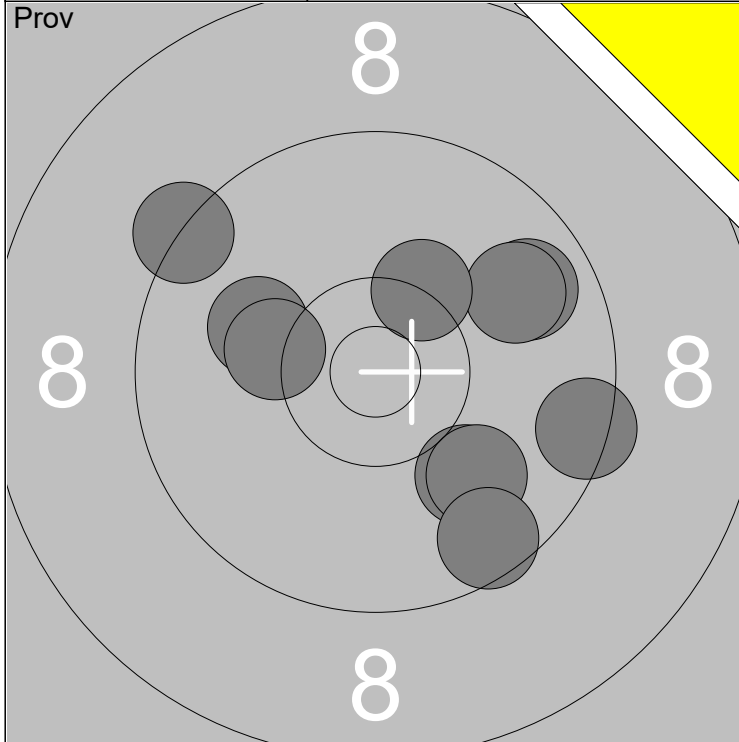

1: 9.4 →	6: 10.2 ←	Serie	95
2: 9.8 ↗	7: 10.0 ↘		
3: 9.8 ↗	8: 10.0 ↘	Total	187
4: 10.1 ←	9: 9.6 ↘		
5: 10.3x ↗	10: 9.3 ↗		

1: 9.5 ←	Serie	49
2: 10.4x ↓		
3: 10.3x ↓	Total	236
4: 10.2 →		
5: 10.7x ←		

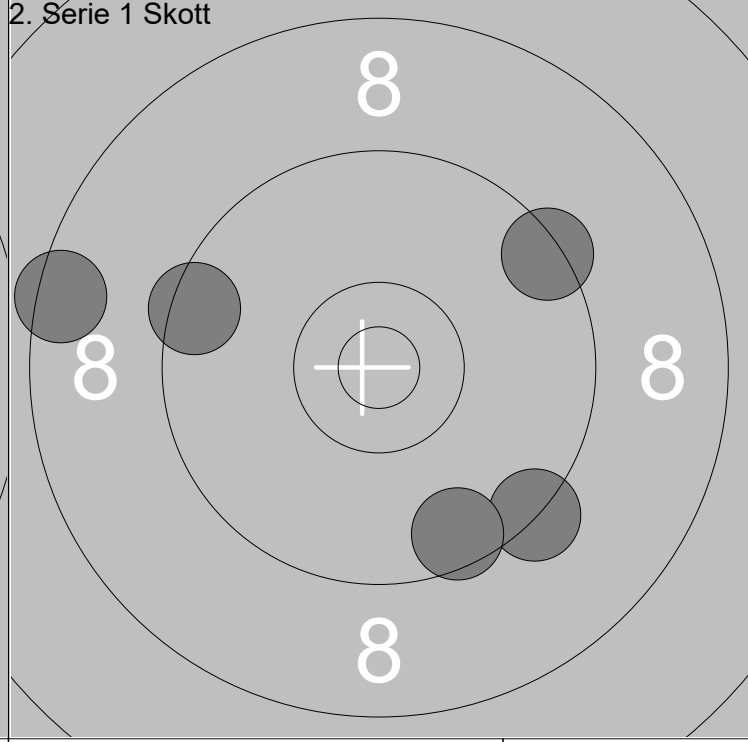
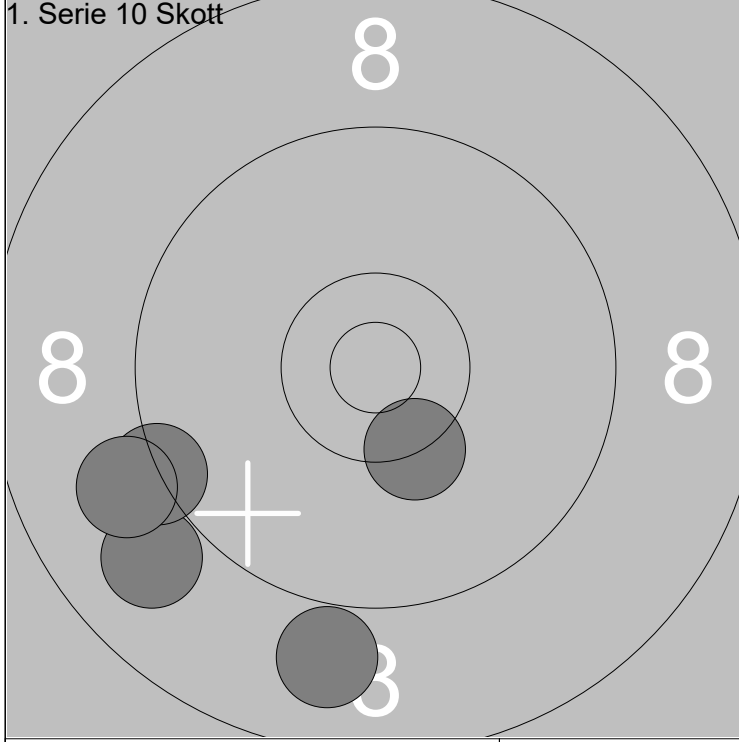

6: 8.9 ↓	Serie	44
7: 8.9 ←		
8: 10.3x ↓	Total	280
9: 9.3 ←		
10: 9.1 ←		

1: 9.5 ←	Serie	44
2: 9.3 ↓		
3: 8.5 ←	Total	324
4: 9.6 ↓		
5: 9.4 ↗		

	<p>1: 9.5 →</p> <p>2: 10.5x↓</p> <p>3: 10.0 →</p> <p>4: 10.4x↖</p> <p>5: 10.9x↗</p> <p>6: 10.3x→</p> <p>7: 10.2 ↑</p> <p>9: 10.7x→</p> <p>10: 10.5x↗</p>		<p>11: 10.5x↖</p>
Serie 89.0		Serie 10.0	
Total 187.0		Total 187.0	

<p>1. Serie 10 Skott</p>	<p>1: 9.9 ↖</p> <p>2: 10.0 →</p> <p>3: 10.5x↗</p> <p>4: 10.4x↖</p> <p>5: 10.4x→</p>	<p>1. Serie 10 Skott</p>	<p>6: 9.0 ↖</p> <p>7: 9.0 ←</p> <p>8: 7.8 ←</p> <p>9: 10.5x↖</p> <p>10: 9.3 ↖</p>
Serie 49.0		Serie 44.0	
Total 236.0		Total 280.0	

<p>2. Serie 1 Skott</p>	<p>1: 8.7 →</p> <p>2: 10.0 ↑</p> <p>3: 10.7x↗</p> <p>4: 10.2 ↖</p> <p>5: 9.1 ↘</p>		
Serie 47.0			
Total 327.0			

	<p>Prov</p> <ol style="list-style-type: none"> 1: 9.8 ↗ 2: 10.3x↘ 3: 9.6 → 4: 10.5x↗ 5: 9.7 ↗ 6: 9.6 ↘ 7: 9.9 ↖ 8: 9.7 → 9: 10.4x↖ 10: 9.9 ↗ <table border="1" style="width:100%; border-collapse: collapse; margin-top: 5px;"> <tr> <td style="text-align: right;">Serie</td> <td style="text-align: right;">93.0</td> </tr> <tr> <td style="text-align: right;">Total</td> <td style="text-align: right;">186.0</td> </tr> </table>	Serie	93.0	Total	186.0		<p>Prov</p> <ol style="list-style-type: none"> 11: 9.6 → 12: 10.2 ↘ <table border="1" style="width:100%; border-collapse: collapse; margin-top: 5px;"> <tr> <td style="text-align: right;">Serie</td> <td style="text-align: right;">19.0</td> </tr> <tr> <td style="text-align: right;">Total</td> <td style="text-align: right;">186.0</td> </tr> </table>	Serie	19.0	Total	186.0
Serie	93.0										
Total	186.0										
Serie	19.0										
Total	186.0										

<p>1. Serie 10 Skott</p>	<ol style="list-style-type: none"> 1: 10.7x↘ 2: 9.6 ↗ 3: 9.9 ← 4: 9.7 ↘ 5: 10.7x↗ <table border="1" style="width:100%; border-collapse: collapse; margin-top: 5px;"> <tr> <td style="text-align: right;">Serie</td> <td style="text-align: right;">47.0</td> </tr> <tr> <td style="text-align: right;">Total</td> <td style="text-align: right;">233.0</td> </tr> </table>	Serie	47.0	Total	233.0	<p>1. Serie 10 Skott</p>	<ol style="list-style-type: none"> 6: 9.1 → 7: 9.6 ↖ 8: 9.8 ↗ 9: 6.5 ← 10: 9.6 ← <table border="1" style="width:100%; border-collapse: collapse; margin-top: 5px;"> <tr> <td style="text-align: right;">Serie</td> <td style="text-align: right;">42.0</td> </tr> <tr> <td style="text-align: right;">Total</td> <td style="text-align: right;">275.0</td> </tr> </table>	Serie	42.0	Total	275.0
Serie	47.0										
Total	233.0										
Serie	42.0										
Total	275.0										

<p>2. Serie 1 Skott</p>	<ol style="list-style-type: none"> 1: 6.4 ↘ 2: 8.8 ← 3: 9.3 ← 4: 9.4 ↗ 5: 8.5 ← <table border="1" style="width:100%; border-collapse: collapse; margin-top: 5px;"> <tr> <td style="text-align: right;">Serie</td> <td style="text-align: right;">40.0</td> </tr> <tr> <td style="text-align: right;">Total</td> <td style="text-align: right;">315.0</td> </tr> </table>	Serie	40.0	Total	315.0		
Serie	40.0						
Total	315.0						

	<p>1: 9.8 →</p> <p>2: 10.5 ↘</p> <p>3: 9.8 ↑</p> <p>4: 9.9 ↑</p> <p>5: 10.0 →</p> <p>6: 9.6 ↗</p> <p>7: 10.2 ↑</p> <p>8: 10.3 ↗</p> <p>9: 8.7 ↗</p> <p>10: 10.1 ↗</p>		<p>11: 9.6 ↗</p> <p>12: 10.4 ↘</p>
Serie 94.0		Serie 19.0	
Total 182.0		Total 182.0	

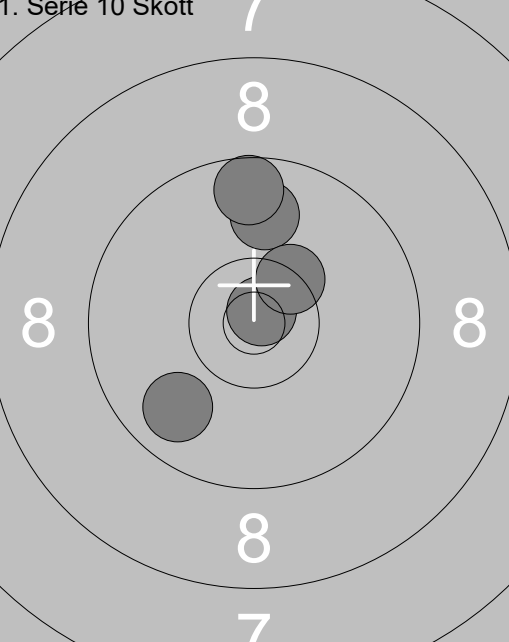
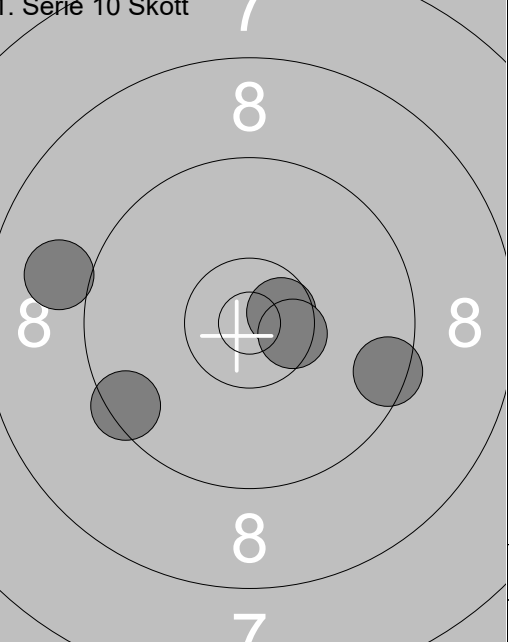
<p>1. Serie 10 Skott</p> 	<p>1: 9.8 ↘</p> <p>2: 10.8 ↗</p> <p>3: 9.9 ↑</p> <p>4: 9.6 ↑</p> <p>5: 10.4 ↗</p>	<p>1. Serie 10 Skott</p> 	<p>6: 9.5 ↘</p> <p>7: 10.6 ↗</p> <p>8: 9.0 ↖</p> <p>9: 9.5 →</p> <p>10: 10.5 ↗</p>
Serie 47.0		Serie 47.0	
Total 229.0		Total 276.0	

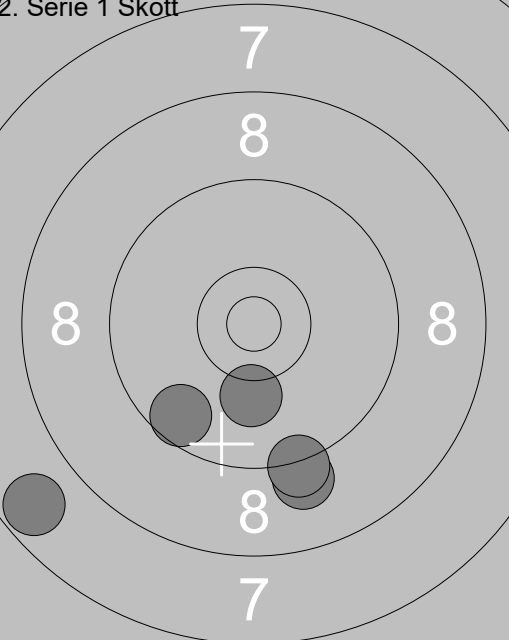
<p>2. Serie 1 Skott</p> 	<p>1: 9.1 ↓</p> <p>2: 10.1 ↓</p> <p>3: 9.2 ↓</p> <p>4: 7.7 ↖</p> <p>5: 9.6 ↘</p>		
Serie 44.0			
Total 320.0			

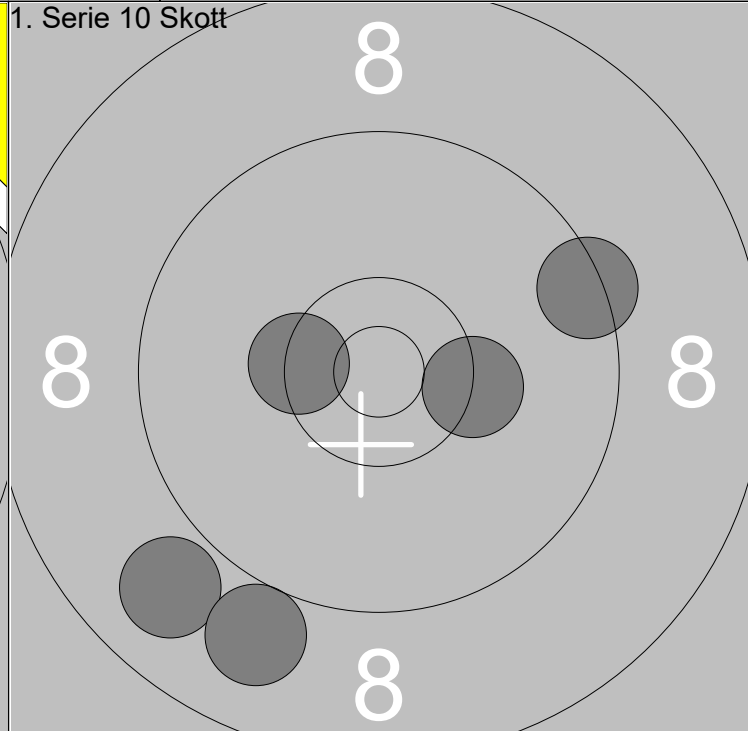
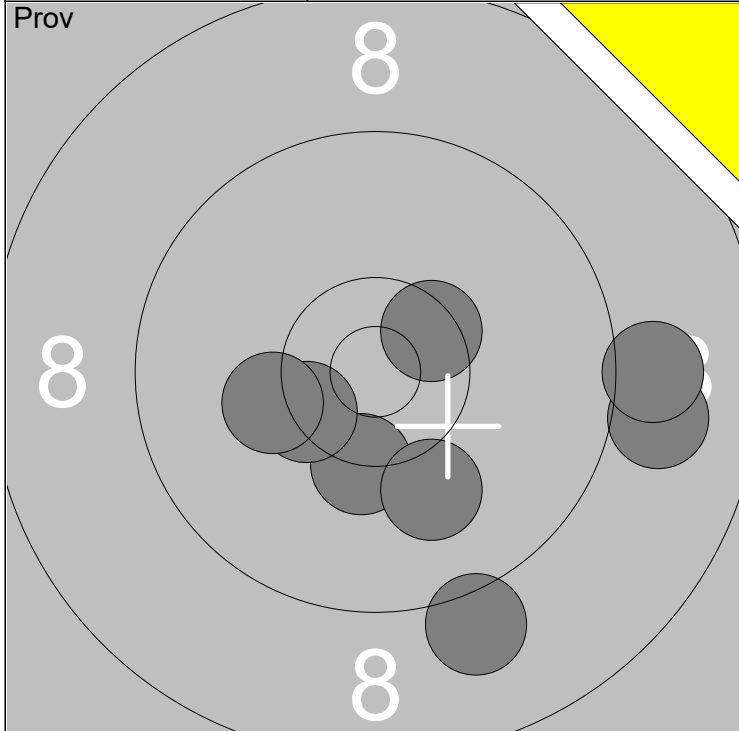

1: 10.3x ↓	6: 10.2 ←	Serie	77
2: 9.0 →	7: 10.1 ↓		
3: 9.0 →	8: 10.5x ↗	Total	182
4: 10.4x ↙			
5: 9.1 ↓			

1: 8.9 ↙	Serie	46
2: 9.4 →		
3: 10.3x →	Total	228
4: 10.4x ↙		
5: 9.0 ↓		

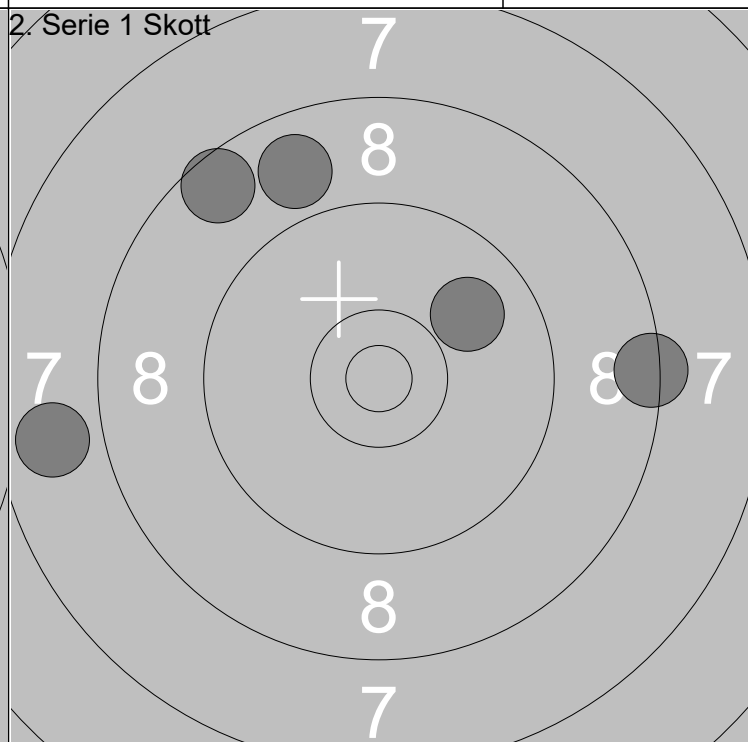
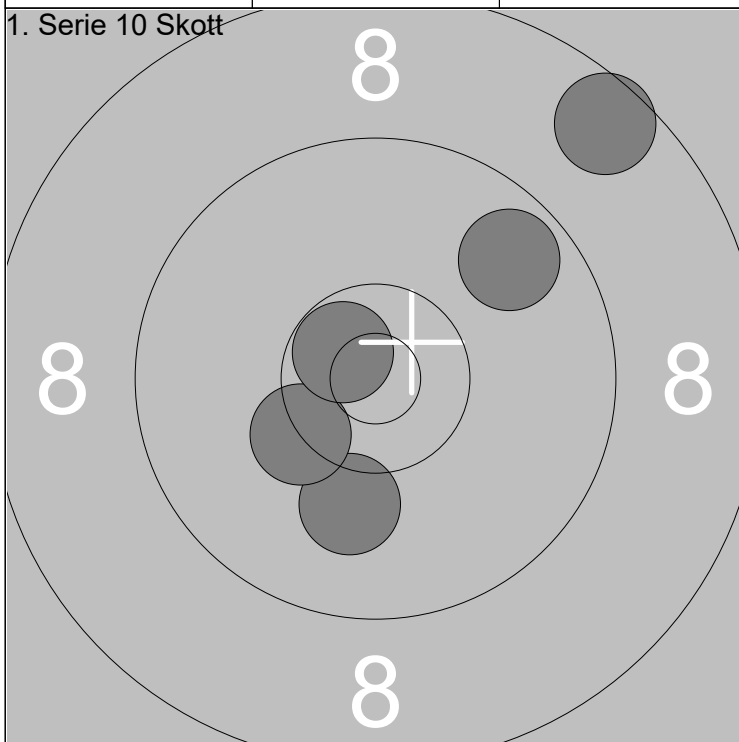

6: 10.1 ↓	Serie	47
7: 8.6 ↗		
8: 10.3x ↙	Total	275
9: 10.7x ↖		
10: 9.7 ↗		

1: 9.9 ↗	Serie	40
2: 8.8 ↖		
3: 8.4 →	Total	315
4: 8.6 ↖		
5: 7.8 ←		

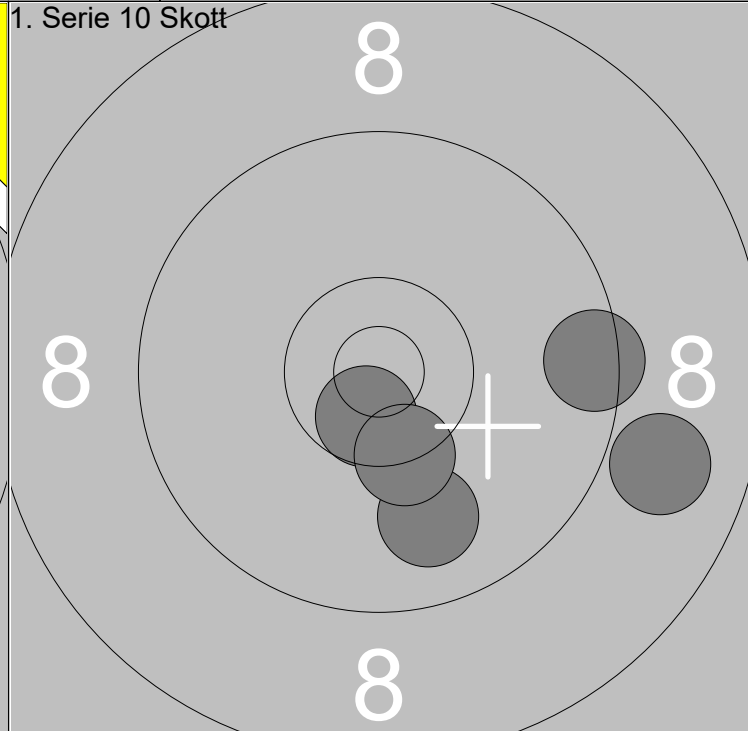
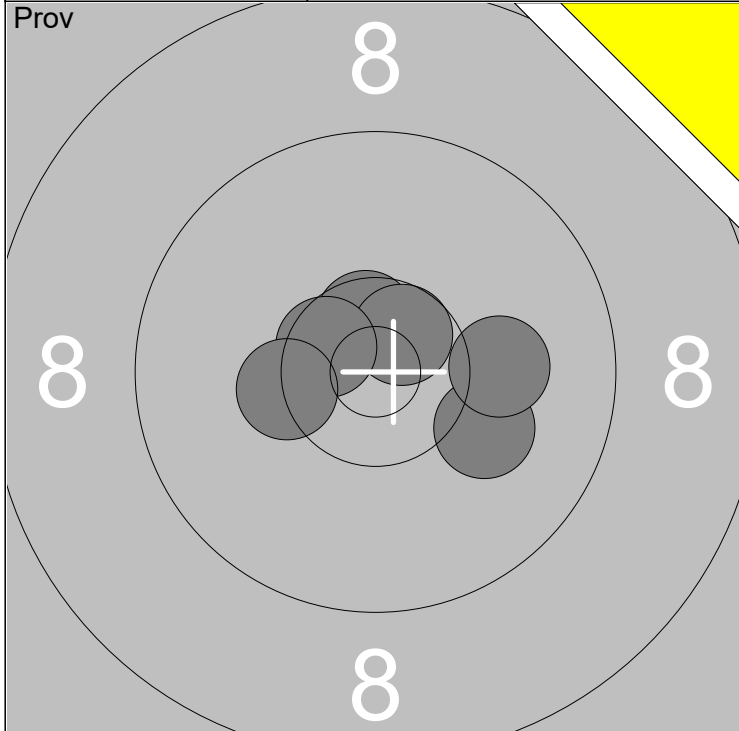

1: 10.6x ↗	6: 10.1 →		
2: 10.6x ↗		Serie	60
3: 10.6x ↖			
4: 10.1 →		Total	179
5: 10.3x ←			

1: 9.5 →			
2: 10.6x ↘		Serie	46
3: 9.9 ↘			
4: 10.4x ↘		Total	225
5: 8.9 →			

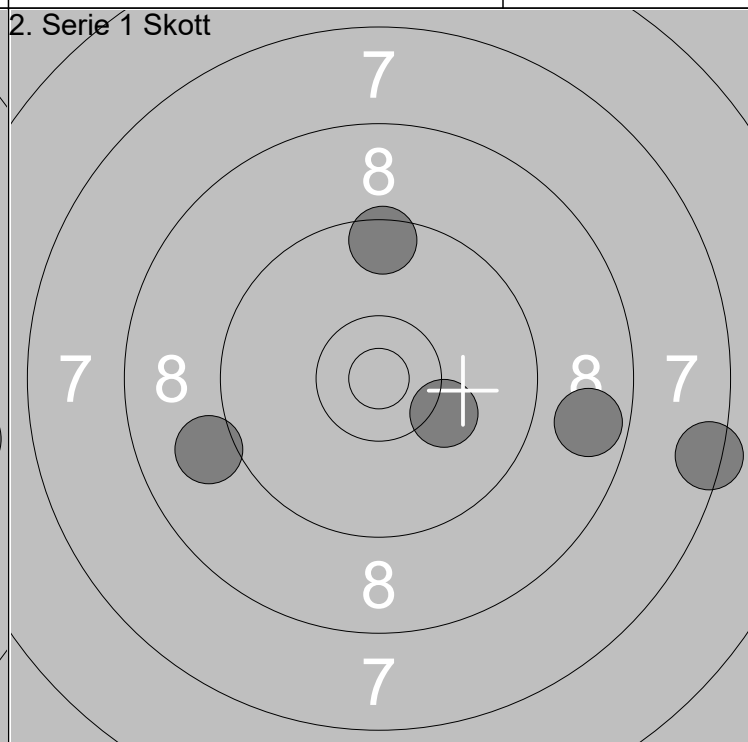
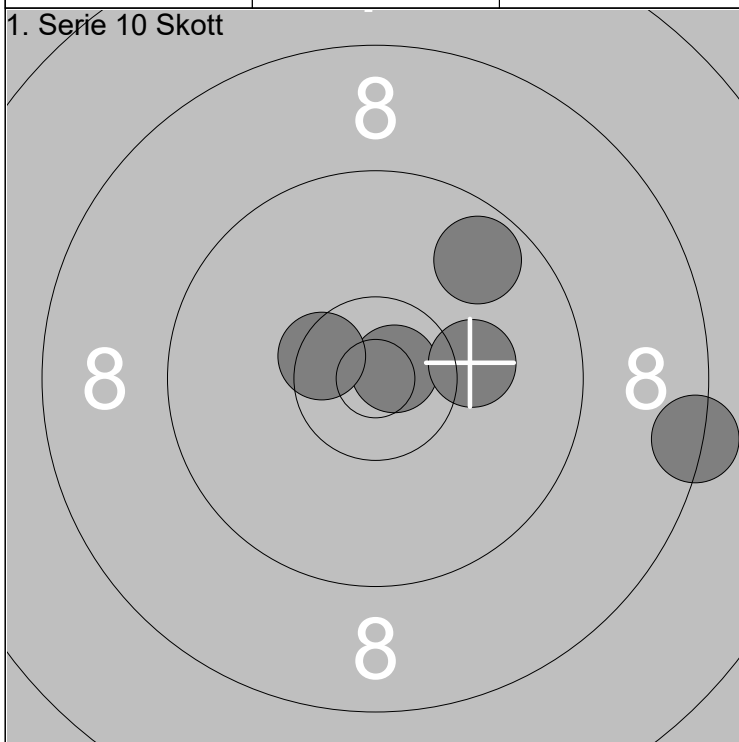

6: 10.8x ↗			
7: 8.4 →		Serie	47
8: 10.2 →			
9: 10.5x ↖		Total	272
10: 9.7 ↗			

1: 9.5 ↗			
2: 8.7 →		Serie	43
3: 7.4 →			
4: 9.0 ↖		Total	315
5: 10.2 ↘			

	1: 10.5x ↘ 2: 10.4x → 3: 9.8 → 4: 10.3x ↗ 5: 8.7 → 6: 10.0 ↘ 7: 10.2 ↘ 8: 10.5x ↗ 9: 9.4 ↗ 10: 10.0 ↗		11: 9.2 ↗
Serie	96.0	Serie	9.0
Total	175.0	Total	175.0

1. Serie 10 Skott 	1: 9.6 ↗ 2: 10.5x ↘ 3: 10.4x ↘ 4: 10.3 ↘ 5: 9.8 ↖		
Serie	48.0	Serie	46.0
Total	223.0	Total	269.0

2. Serie 1 Skott 	1: 9.8 ↘ 2: 9.2 ↗ 3: 9.6 ← 4: 9.0 ↖ 5: 7.3 ←		
Serie	43.0		
Total	312.0		

Skjutlag

6

Tavla

8

Roger Hjalström

Ramselefors

Ununge

Sen-S

St

09.07.2024

Tavelträffen Korthäll 2024

Ramselefors SKF

Prov

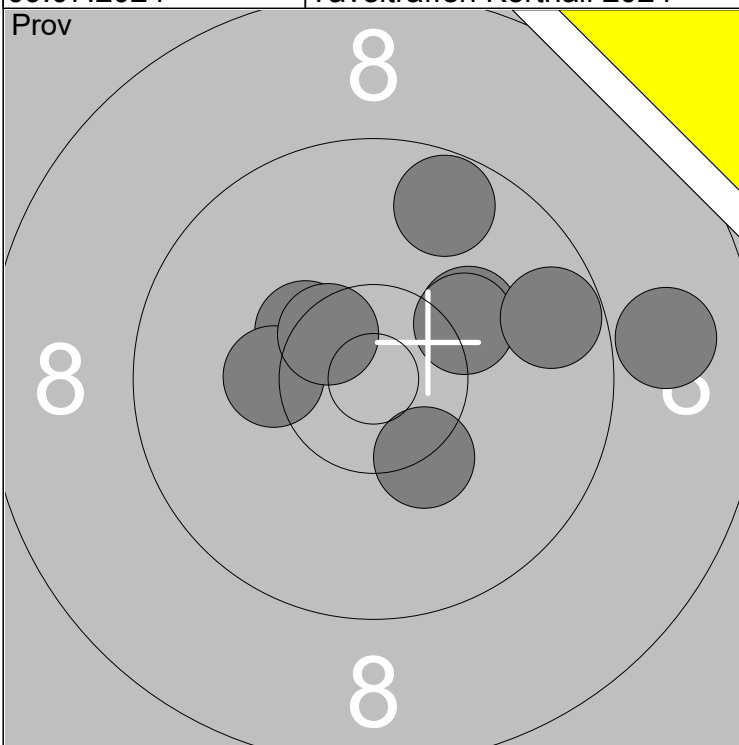

1. Serie 10 Skott

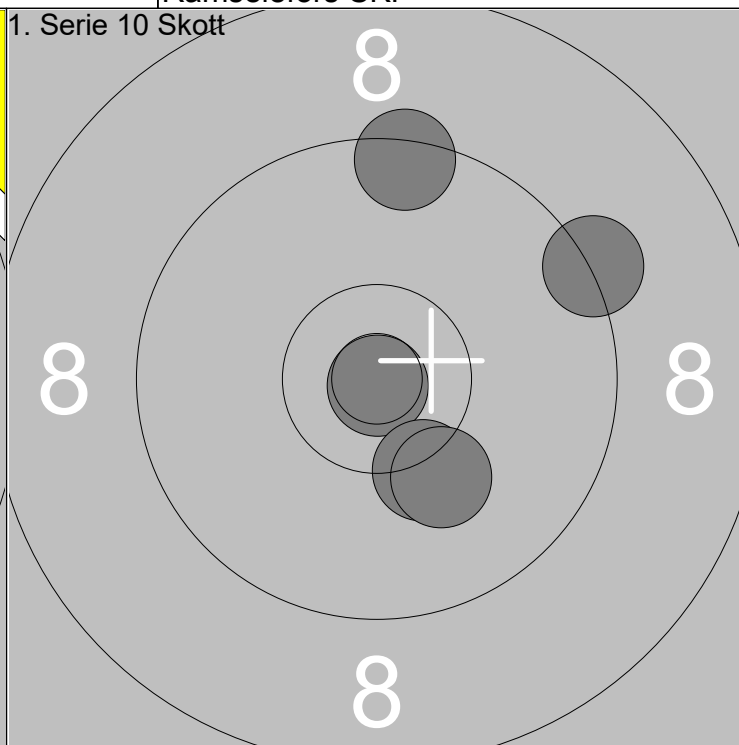

1: 10.2 ↗
 2: 10.4x ↖
 3: 10.2 ↗
 4: 8.9 →
 5: 9.7 →

6: 10.3 ←
 7: 9.7 ↗
 8: 10.3x ↘
 9: 10.5x ↖

Serie 86
 Total 175

1: 10.9x ↓
 2: 10.2 ↓
 3: 10.1 ↓
 4: 9.3 ↗
 5: 9.4 ↑

Serie 48
 Total 223

1. Serie 10 Skott

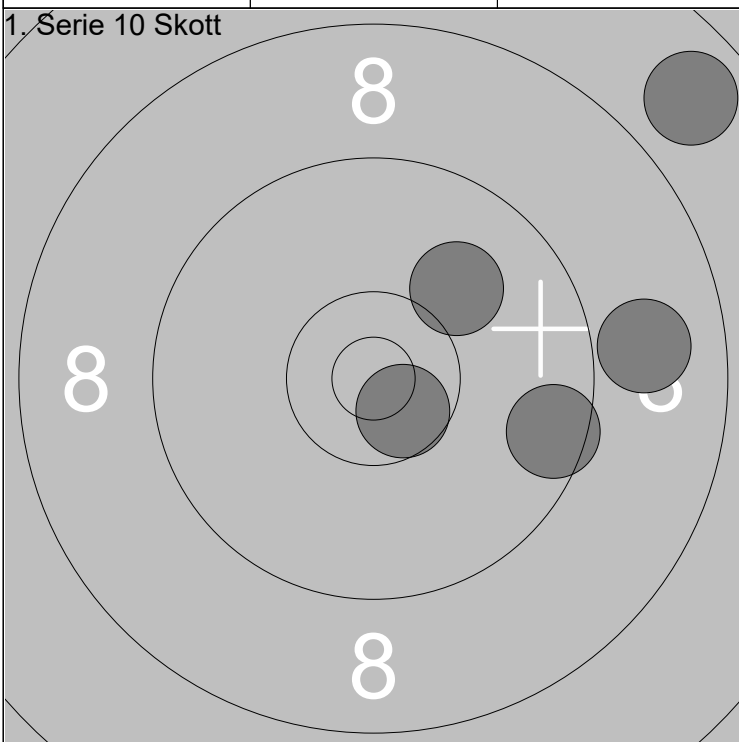

2. Serie 1 Skott

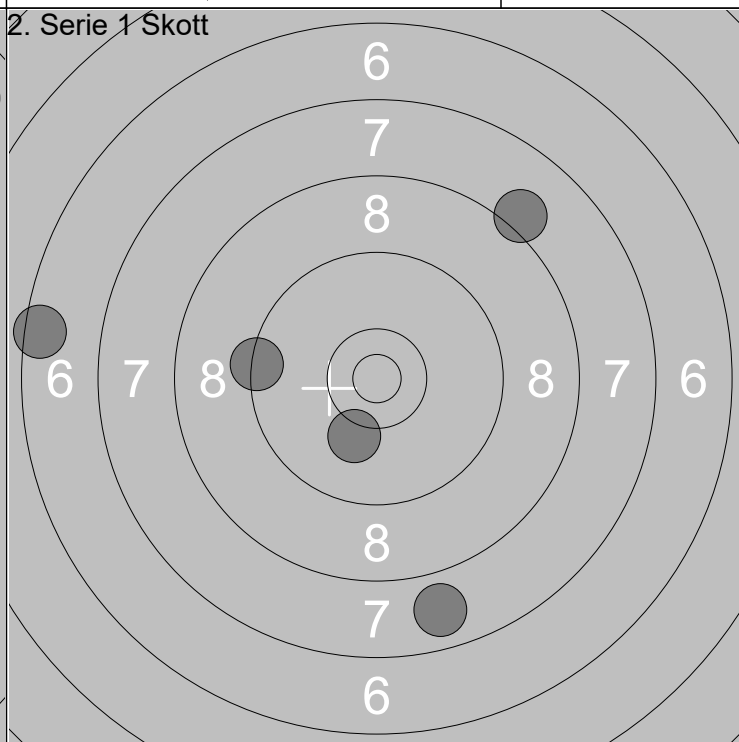

6: 10.0 ↗
 7: 8.9 →
 8: 7.8 ↗
 9: 9.5 →
 10: 10.6x ↓

Serie 44
 Total 267

1: 9.4 ←
 2: 6.5 ←
 3: 7.8 ↓
 4: 10.1 ↓
 5: 8.1 ↗

Serie 40
 Total 307

	<p>1: 9.4 →</p> <p>2: 10.3 ↗</p> <p>3: 9.5 ←</p> <p>4: 9.8 ↓</p> <p>5: 10.3x ↓</p> <p>6: 9.0 ↗</p> <p>7: 9.3 ↗</p> <p>8: 9.8 ↗</p> <p>9: 8.9 ←</p> <p>10: 9.4 ←</p>		<p>11: 10.3x ↓</p>
Serie 91.0		Serie 10.0	
Total 174.0		Total 174.0	

<p>1. Serie 10 Skott</p>	<p>1: 10.2 ↓</p> <p>2: 8.7 ↓</p> <p>3: 9.7 ↓</p> <p>4: 10.2 →</p> <p>5: 9.5 →</p>		<p>6: 8.6 ↗</p> <p>7: 8.8 ↗</p> <p>8: 9.0 ↓</p> <p>9: 8.7 ↓</p> <p>10: 9.5 ↓</p>
Serie 46.0		Serie 42.0	
Total 220.0		Total 262.0	

<p>2. Serie 1 Skott</p>	<p>1: 5.4 →</p> <p>2: 9.8 ←</p> <p>3: 9.2 ↓</p> <p>4: 8.9 ↗</p> <p>5: 7.5 ↗</p>		
Serie 38.0			
Total 300.0			

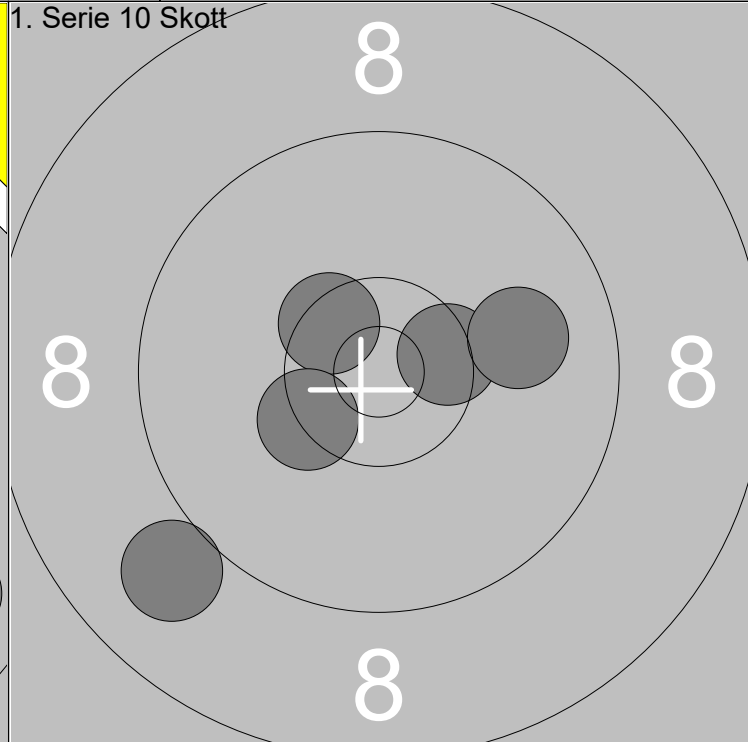
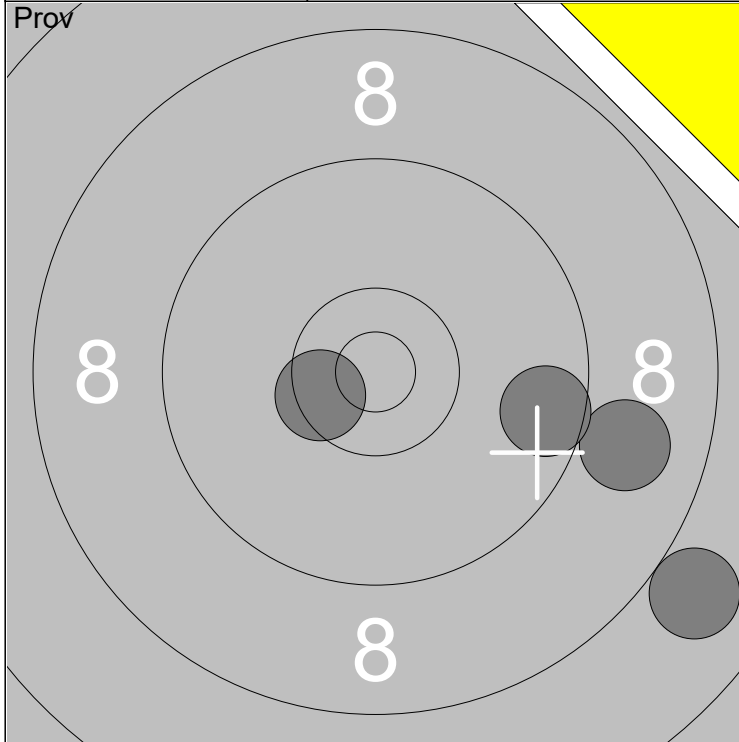

1: 7.9 ↘	
2: 8.9 →	
3: 9.6 →	
4: 10.5x ←	
Serie	34
Total	171

1: 10.5x →	
2: 10.5x ↖	
3: 10.4x ↙	
4: 10.0 →	
5: 9.0 ↙	
Serie	49
Total	220

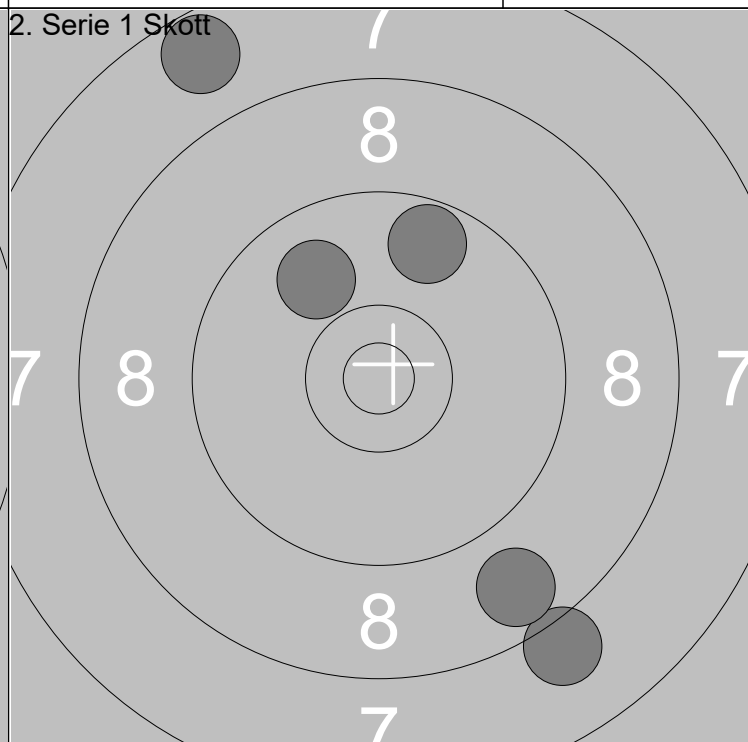
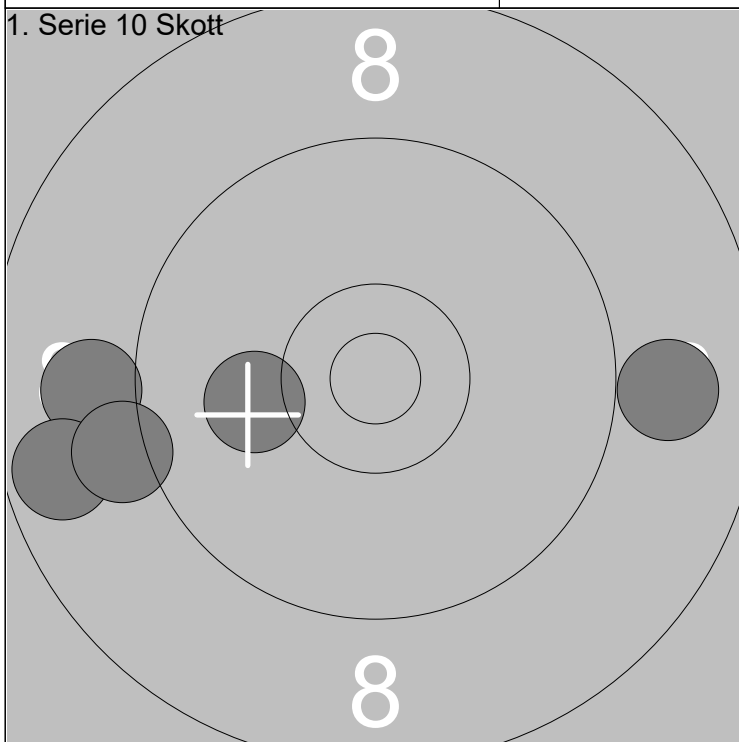

6: 10.1 ←	
7: 9.0 ←	
8: 8.7 ←	
9: 9.1 ←	
10: 8.9 →	
Serie	44
Total	264

1: 8.1 ↘	
2: 7.7 ↗	
3: 9.9 ↗	
4: 8.7 ↘	
5: 9.7 ↗	
Serie	41
Total	305

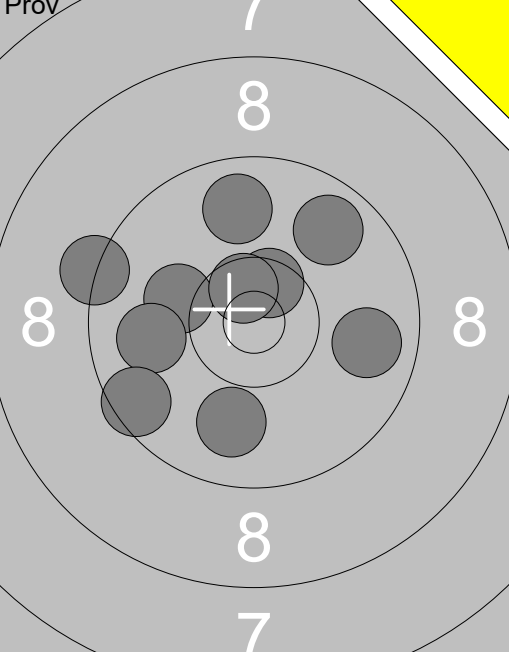
	<p>1: 10.5x ↗</p> <p>2: 9.8 →</p> <p>3: 9.8 ↗</p> <p>4: 9.8 ↑</p> <p>5: 10.2 ↙</p> <p>6: 10.6x ↗</p> <p>7: 9.9 ↓</p> <p>8: 9.9 ←</p> <p>9: 9.3 ↙</p> <p>10: 9.5 ↙</p>	<p>11: 9.8 ↗</p>
Serie 93.0		Serie 9.0
Total 170.0		Total 170.0

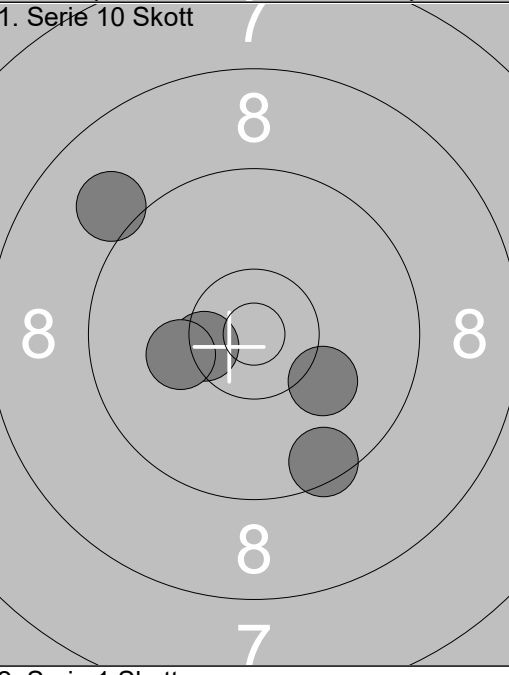
<p>1. Serie 10 Skott</p> 	<p>1: 9.5 ↓</p> <p>2: 10.4x ↙</p> <p>3: 10.2 ↙</p> <p>4: 10.1 ↘</p> <p>5: 9.0 ↗</p>	<p>6: 8.8 ↘</p> <p>7: 7.6 ↘</p> <p>8: 10.0 ↙</p> <p>9: 9.0 ↓</p> <p>10: 9.4 ←</p>
Serie 48.0		Serie 43.0
Total 218.0		Total 261.0

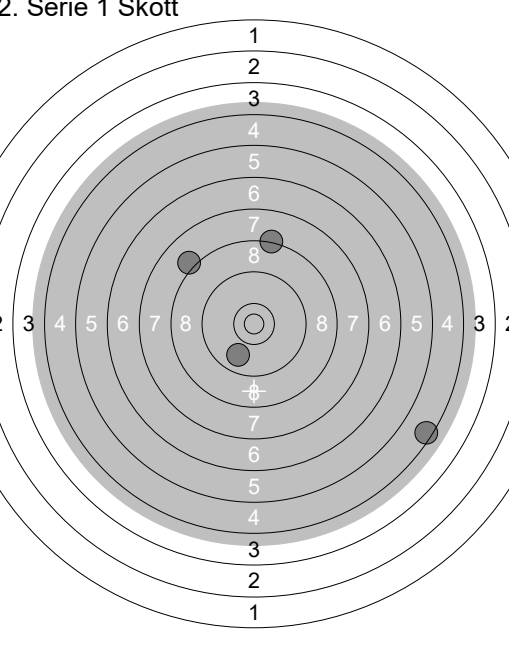
<p>2. Serie 1 Skott</p> 	<p>1: 4.5 ↘</p> <p>2: 0.0 ↓</p> <p>3: 8.1 ↗</p> <p>4: 9.9 ↓</p> <p>5: 8.3 ↑</p>	
Serie 29.0		
Total 290.0		

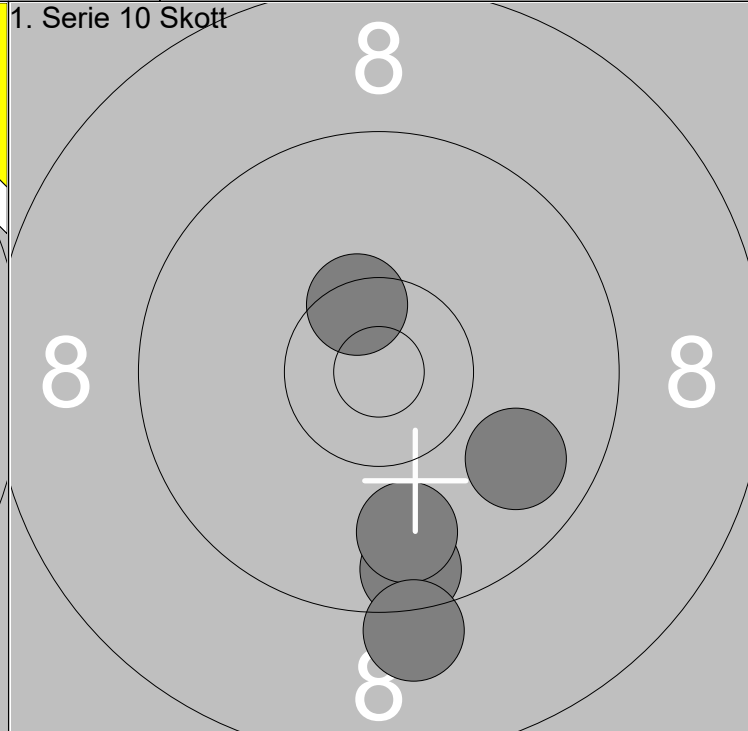
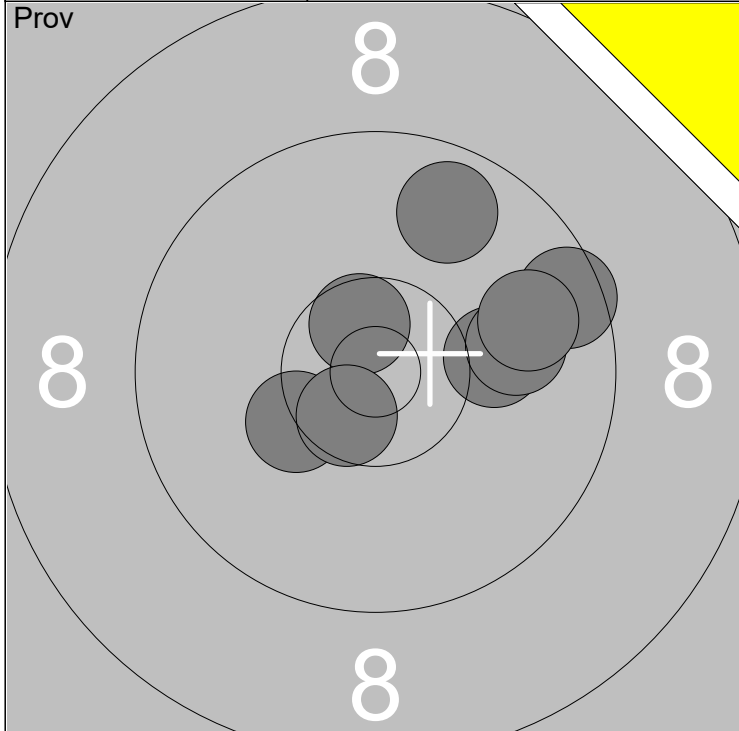

1: 10.1 →	6: 9.8 →	Serie	77
2: 9.5 →	7: 10.3x ↙		
3: 9.7 ↗	8: 10.6x ↘	Total	165
4: 10.6x ↗			
5: 10.0 →			

1: 9.6 ↓	Serie	46
2: 9.8 ↓		
3: 9.8 →	Total	211
4: 10.5x ↗		
5: 9.2 ↓		

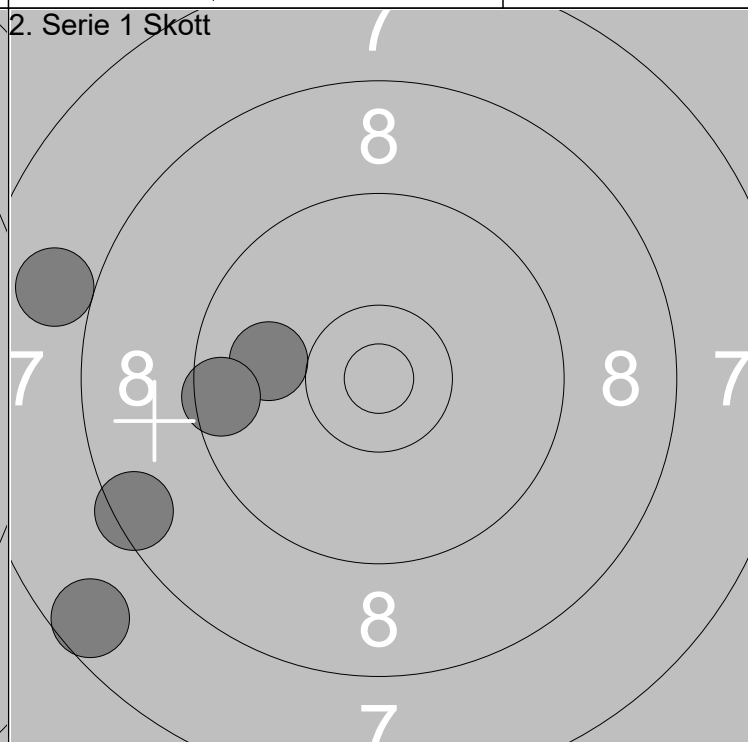
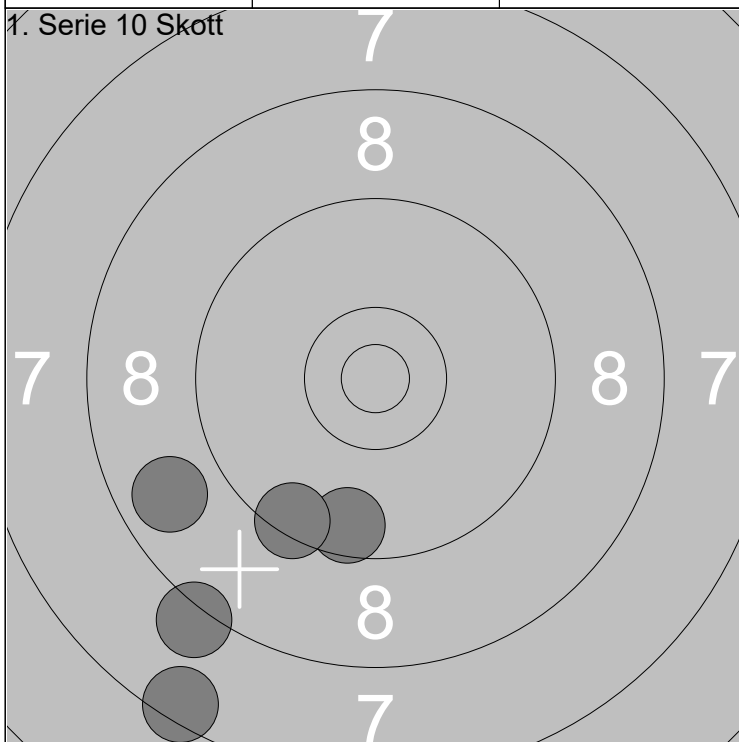

6: 8.2 ↘	Serie	41
7: 9.6 ↓		
8: 9.4 ↓	Total	252
9: 7.5 ↓		
10: 8.8 ↙		

1: 7.6 ↙	Serie	41
2: 10.0 ←		
3: 8.5 ↙	Total	293
4: 9.5 ←		
5: 7.9 ↙		

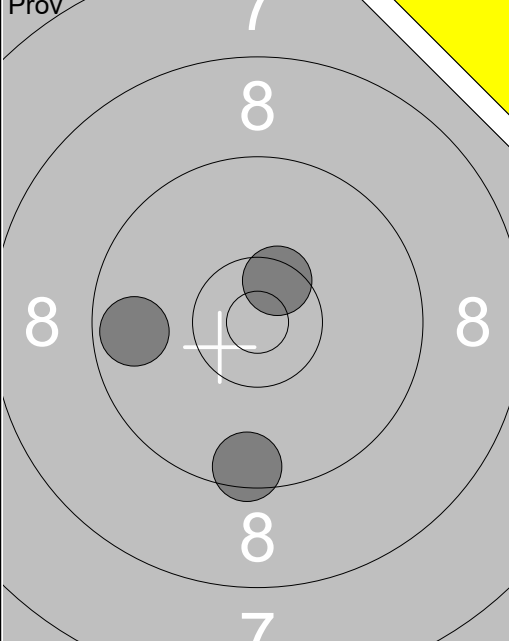
	<p>1: 9.8 ↘</p> <p>2: 8.6 ➤</p> <p>3: 9.9 ➔</p> <p>4: 8.9 ↙</p> <p>5: 10.1 ↑</p> <p>6: 9.7 ↖</p> <p>7: 9.9 ➔</p> <p>8: 10.3x↑</p> <p>9: 10.3 ➔</p> <p>10: 10.0 ↙</p>		<p>11: 9.5 ↓</p> <p>12: 10.5x↗</p> <p>13: 9.7 ←</p>
Serie 92.0		Serie 28.0	
Total 162.0		Total 162.0	

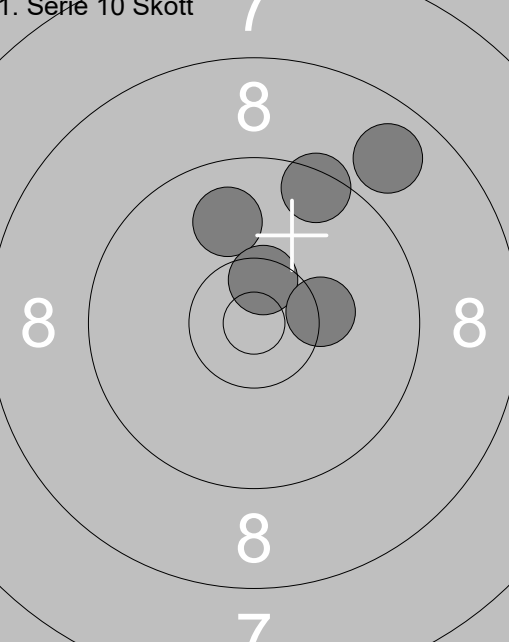
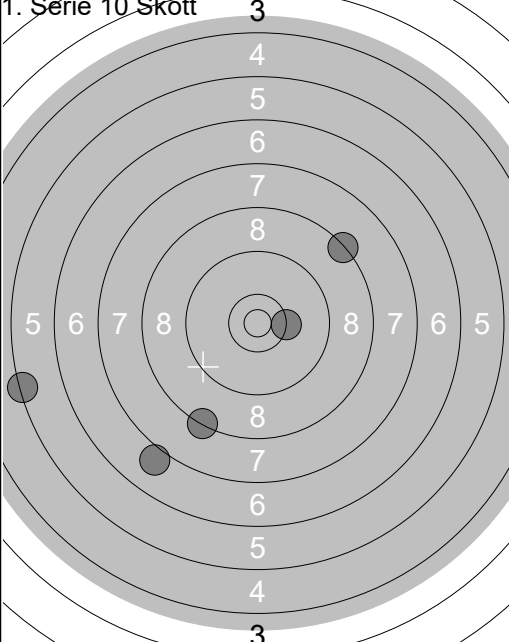
<p>1. Serie 10 Skott</p> 	<p>1: 9.9 ↑</p> <p>2: 10.5x↗</p> <p>3: 8.8 ↗</p> <p>4: 9.5 ↑</p> <p>5: 10.3 ➔</p>	<p>1. Serie 10 Skott</p> 	<p>6: 8.3 ↘</p> <p>7: 8.3 ↗</p> <p>8: 5.4 ←</p> <p>9: 7.0 ↘</p> <p>10: 10.3x➔</p>
Serie 46.0		Serie 38.0	
Total 208.0		Total 246.0	

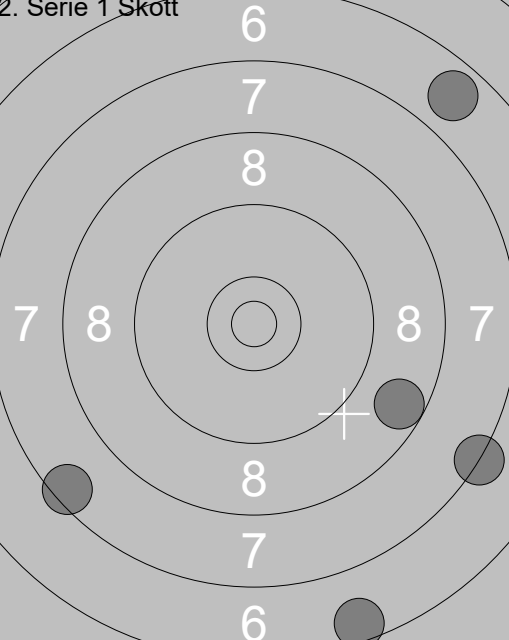
<p>2. Serie 1 Skott</p> 	<p>1: 7.5 ↙</p> <p>2: 6.8 ↗</p> <p>3: 8.6 ➤</p> <p>4: 6.6 ↓</p> <p>5: 7.3 ➤</p>		
Serie 34.0			
Total 280.0			

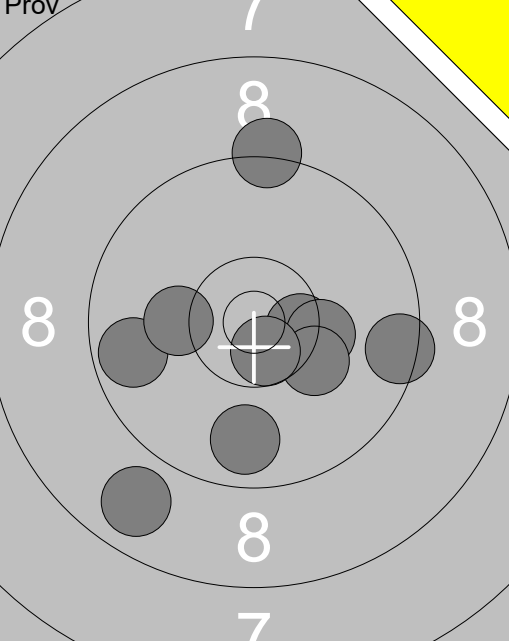
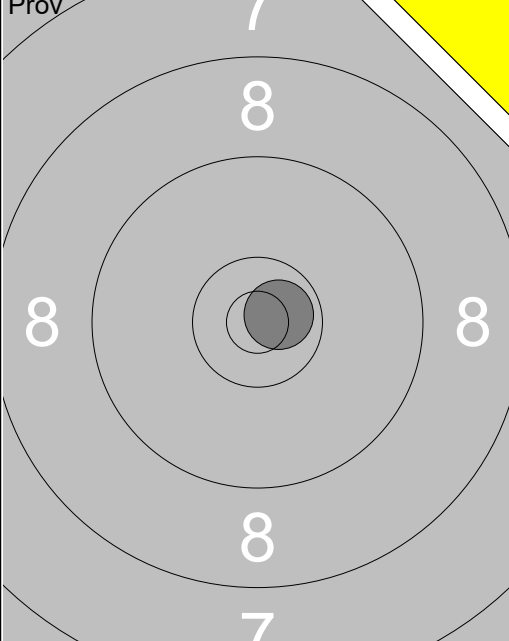
	<p>1: 9.7 ←</p> <p>2: 9.5 →</p> <p>3: 10.5x➤</p> <p>4: 9.8 ↓</p> <p>5: 10.3➤</p> <p>6: 10.2➤</p> <p>7: 10.6x↘</p> <p>8: 8.8 ↙</p> <p>9: 9.3 ↑</p> <p>10: 10.2←</p>		<p>11: 10.7x➤</p>
Serie 94.0		Serie 10.0	
Total 191.0		Total 191.0	

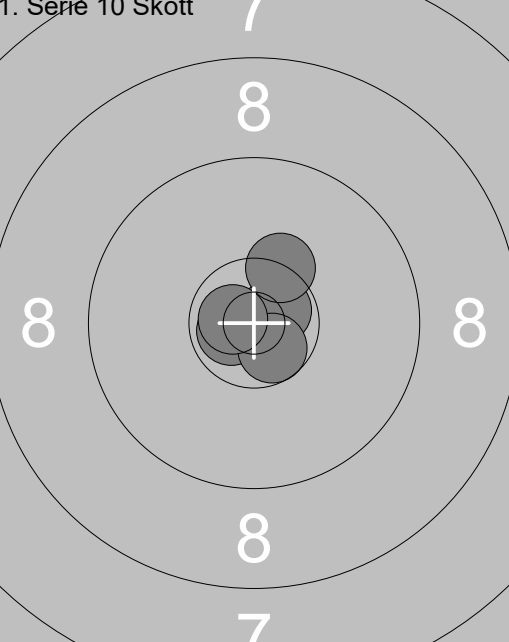
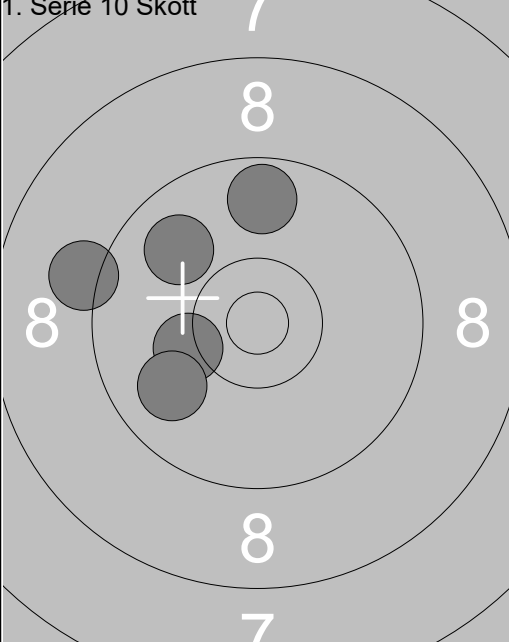
<p>1. Serie 10 Skott</p> 	<p>1: 10.7x➤</p> <p>2: 10.7x↘</p> <p>3: 10.3x↗</p> <p>4: 10.6x↘</p> <p>5: 10.7x↘</p>		<p>6: 9.9 ↖</p> <p>7: 9.2 ←</p> <p>8: 9.7 ↑</p> <p>9: 10.2←</p> <p>10: 9.9 ↙</p>
Serie 50.0		Serie 46.0	
Total 241.0		Total 287.0	

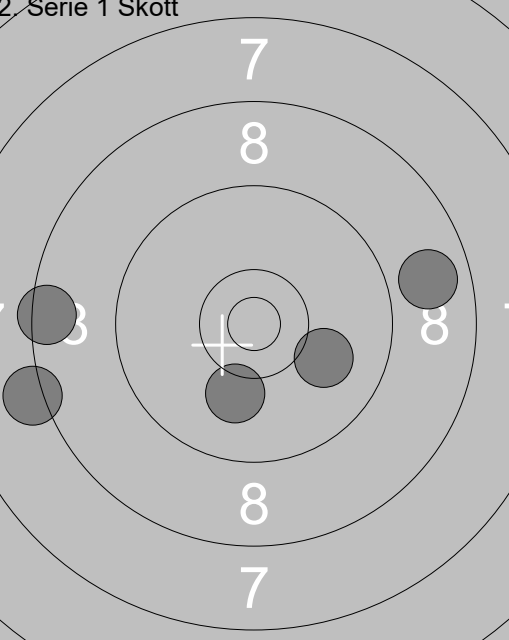
<p>2. Serie 1 Skott</p> 	<p>1: 10.0➤</p> <p>2: 8.5 ←</p> <p>3: 8.8 →</p> <p>4: 8.2 ←</p> <p>5: 10.1 ↓</p>		
Serie 44.0			
Total 331.0			

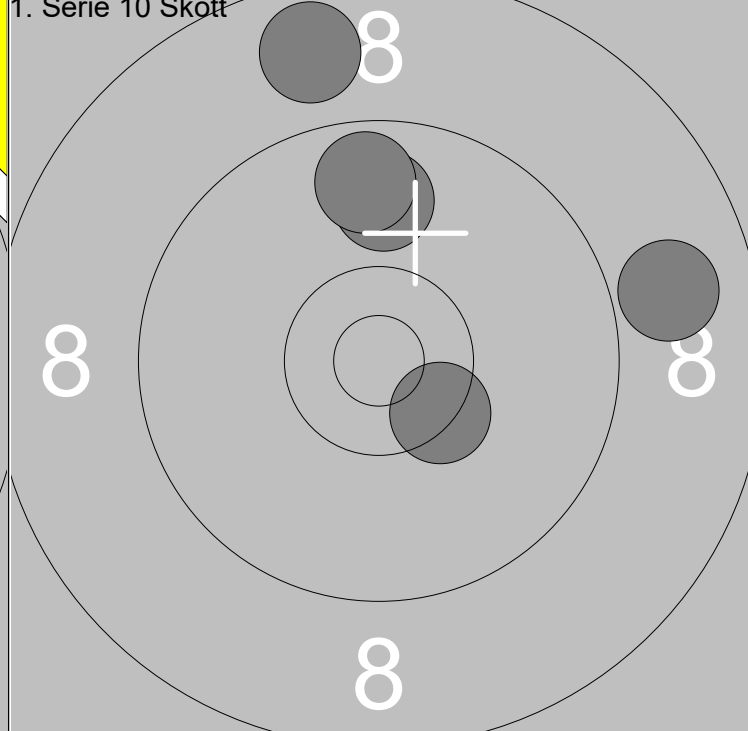
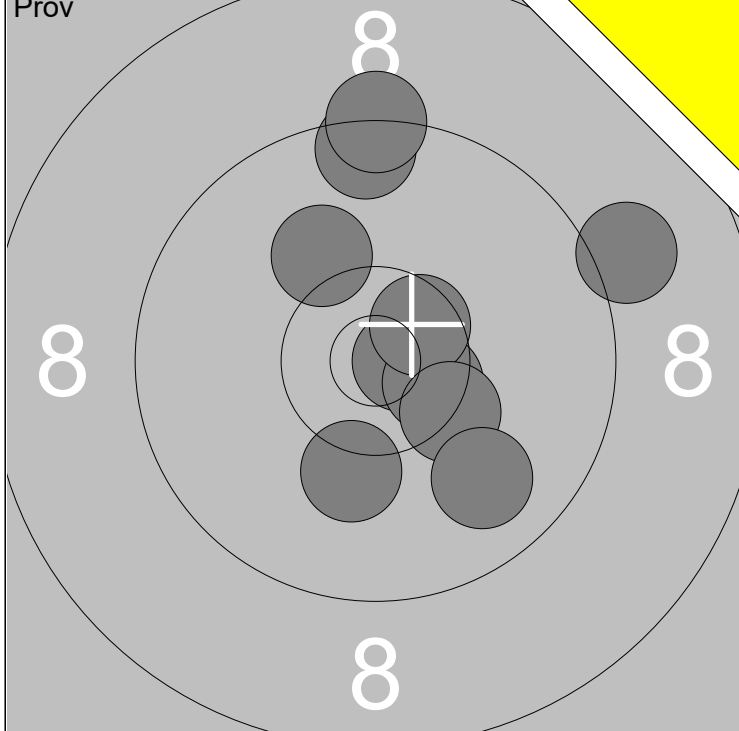

1: 9.5	↑	6: 10.8x	→	Serie	96
2: 10.1	↖	7: 10.5x	→		
3: 9.3	↑	8: 10.6x	↗	Total	184
4: 10.2	↓	9: 10.3x	↘		
5: 9.1	↗	10: 9.9	↘		

1: 8.9	→	Serie	44
2: 8.8	↑		
3: 9.8	↑	Total	228
4: 9.7	↑		
5: 10.4x	↘		

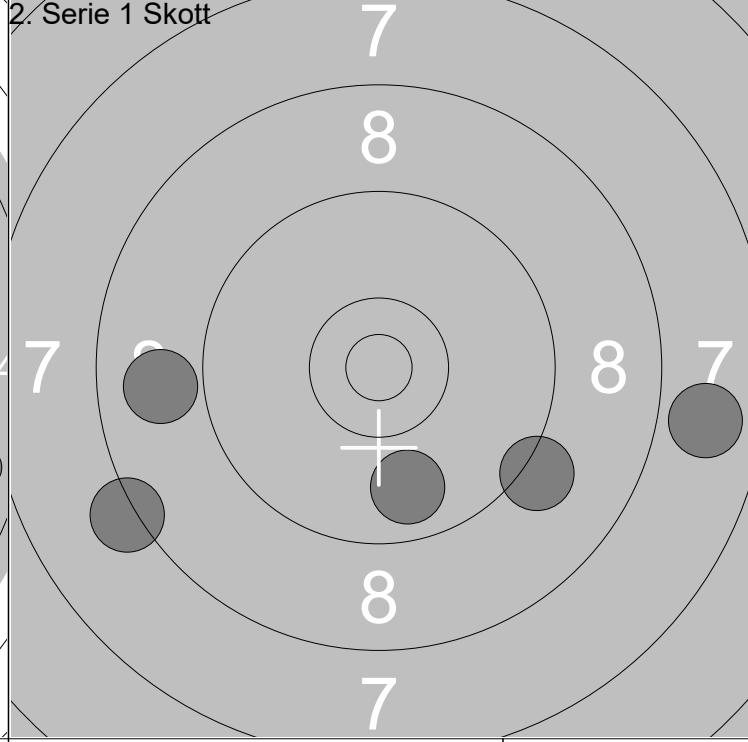
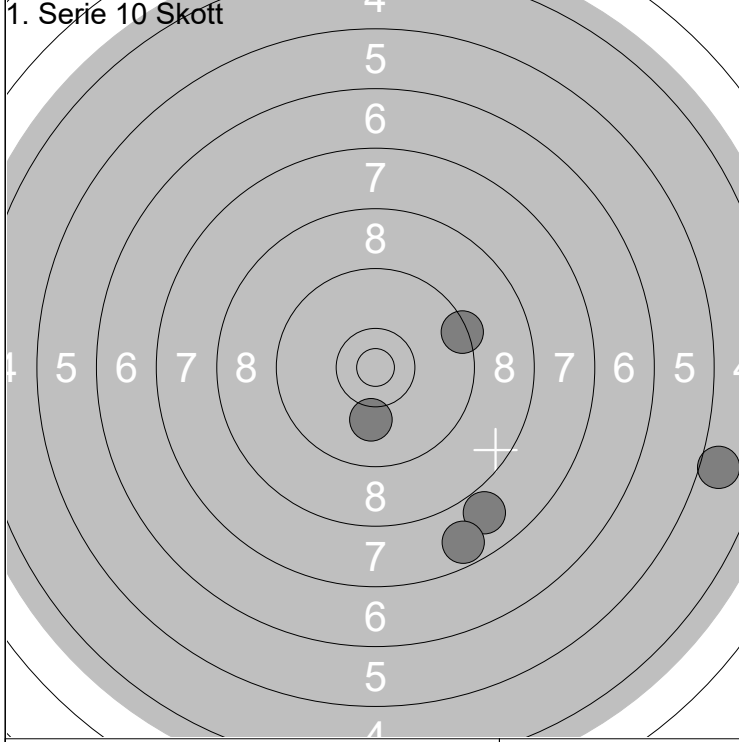

6: 9.4	→	Serie	38
7: 7.9	↘		
8: 5.0	→	Total	266
9: 10.1	↓		
10: 7.7	↘		

1: 7.9	→	Serie	41
2: 8.9	←		
3: 9.8	↓	Total	307
4: 9.2	↘		
5: 8.2	↙		

	<p>1: 9.6 ↘</p> <p>2: 7.9 →</p> <p>3: 10.6x→</p> <p>4: 10.1↖</p> <p>5: 10.8x↓</p> <p>6: 9.1 →</p> <p>7: 9.0 →</p> <p>8: 10.1→</p> <p>9: 9.7 ↗</p> <p>10: 9.7 →</p>		<p>11: 9.4 →</p> <p>12: 9.9 ↖</p> <p>13: 9.8 ↖</p> <p>14: 9.3 ↖</p> <p>15: 9.1 ↗</p>
Serie 92.0		Serie 45.0	
Total 182.0		Total 182.0	

<p>1. Serie 10 Skott</p>	<p>1: 9.7 ↘</p> <p>2: 7.9 ↖</p> <p>3: 8.4 ↗</p> <p>4: 10.0→</p> <p>5: 8.6 ↖</p>	<p>1. Serie 10 Skott</p>	<p>6: 8.7 ↖</p> <p>7: 10.0 ↗</p> <p>8: 8.4 →</p> <p>9: 9.4 →</p> <p>10: 6.8 ↖</p>
Serie 42.0		Serie 41.0	
Total 224.0		Total 265.0	

<p>2. Serie 1 Skott</p>	<p>1: 10.0↗</p> <p>2: 7.9 →</p> <p>3: 8.8 ↗</p> <p>4: 8.7 →</p> <p>5: 8.1 →</p>		
Serie 41.0			
Total 306.0			

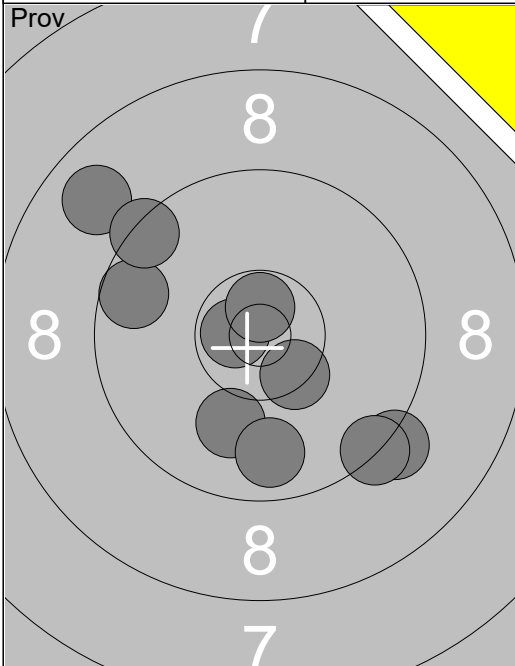

11:	9.6	↗
14:	10.5	↗
Serie	19.0	
Total	182.0	

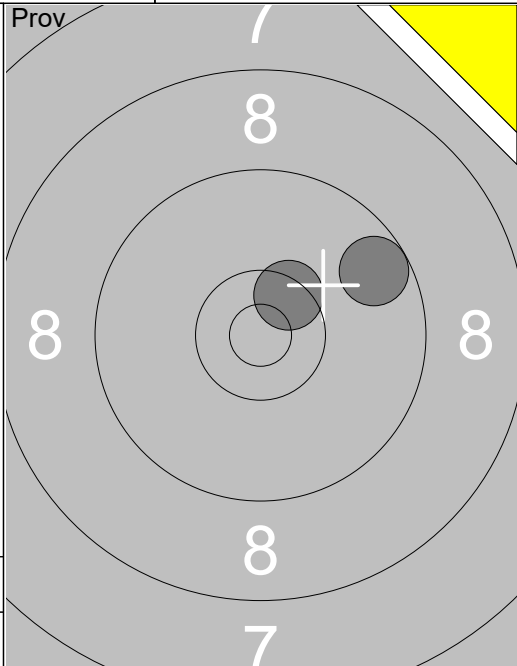

6:	7.0	↓
7:	9.3	→
8:	9.9	↓
9:	9.8	↓
10:	10.3	↘
Serie	44.0	
Total	268.0	

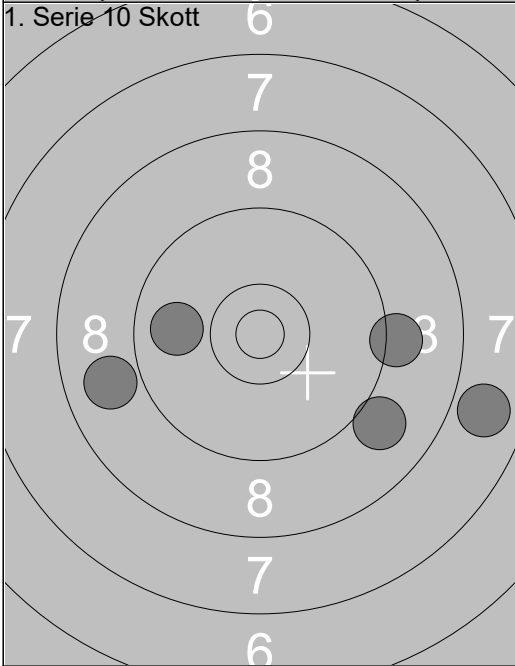

Serie	48.0	
Total	316.0	

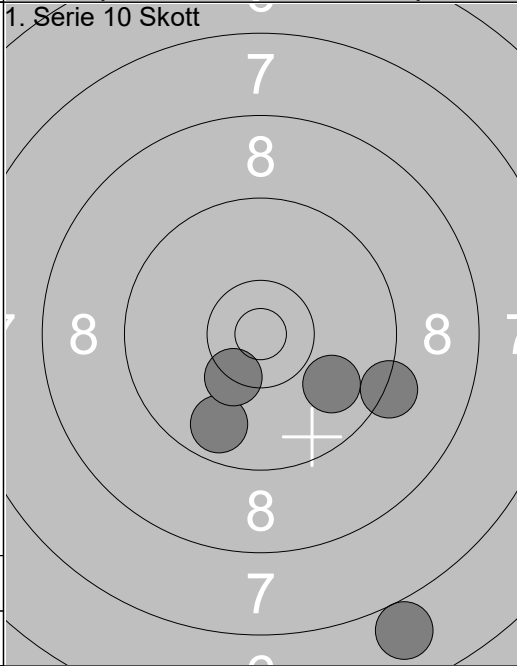

Serie	48.0	
Total	316.0	

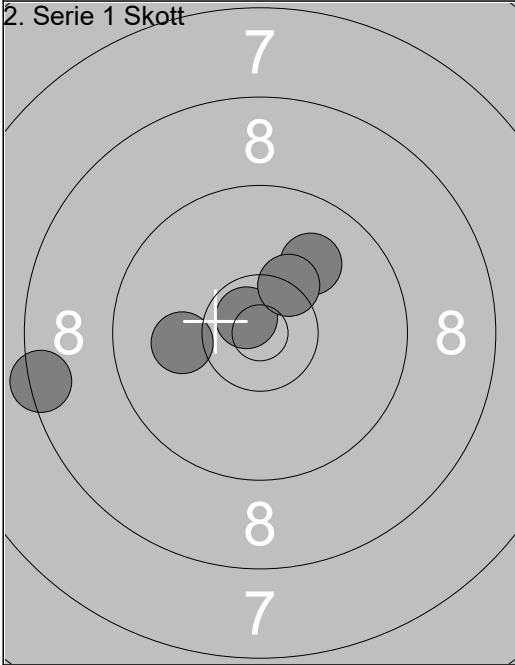

Serie	48.0	
Total	316.0	

Serie	48.0	
Total	316.0	

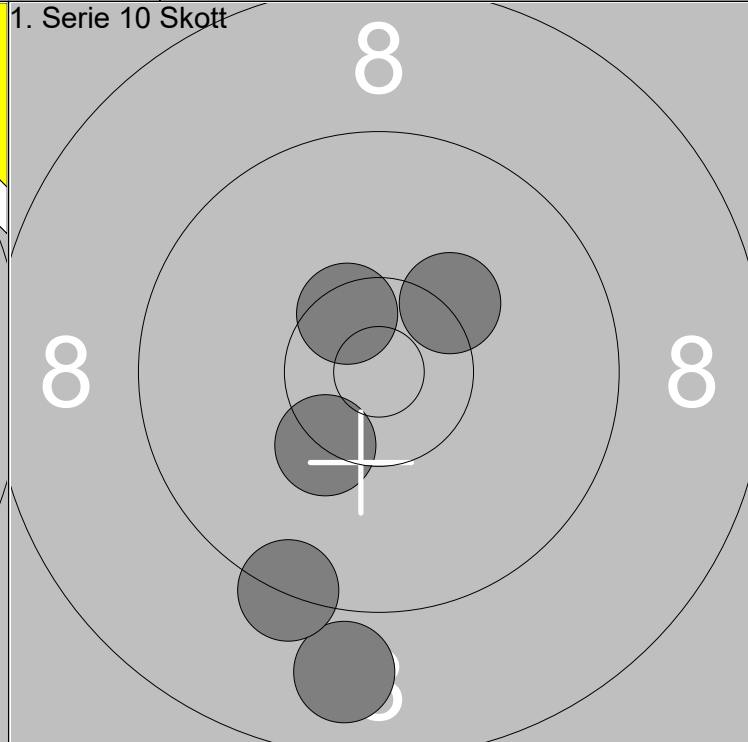
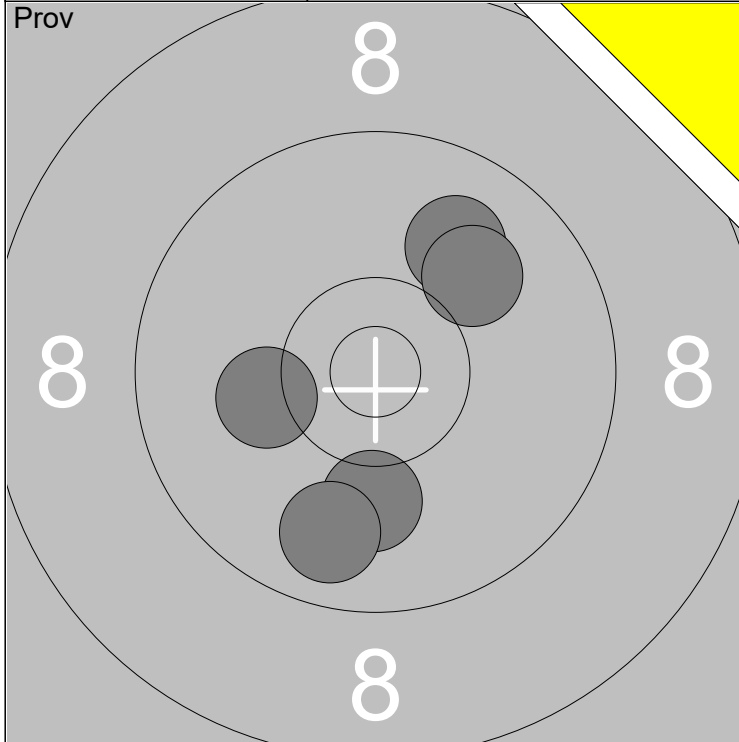

1: 10.1	↓	Serie	48
2: 9.9	↗		
3: 10.0	↗		
4: 9.8	↓		
5: 10.2	←		
Total		182	

1: 8.9	↓	Serie	47
2: 10.3x	↙		
3: 10.5x	↖		
4: 10.3	↗		
5: 9.3	↓		
Total		229	

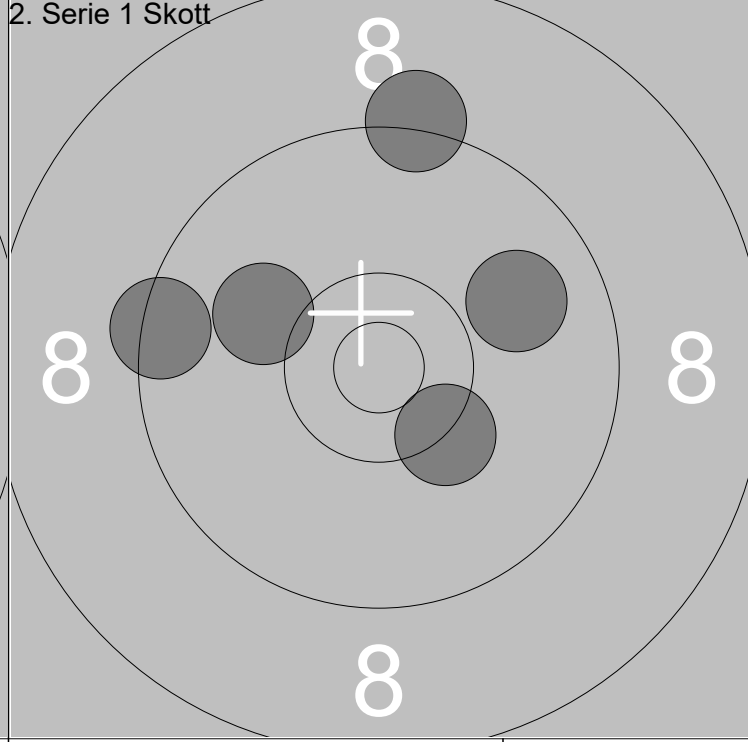
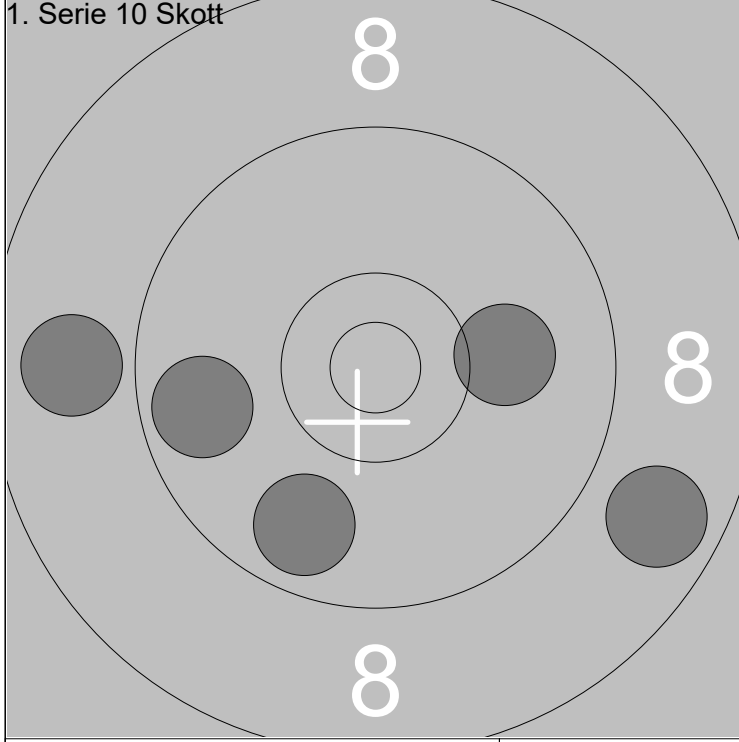

6: 8.8	→	Serie	44
7: 9.8	↓		
8: 8.9	←		
9: 9.7	←		
10: 10.1	→		
Total		273	

1: 9.4	←	Serie	47
2: 10.3x	↘		
3: 9.9	↗		
4: 10.1	↖		
5: 9.2	↑		
Total		320	

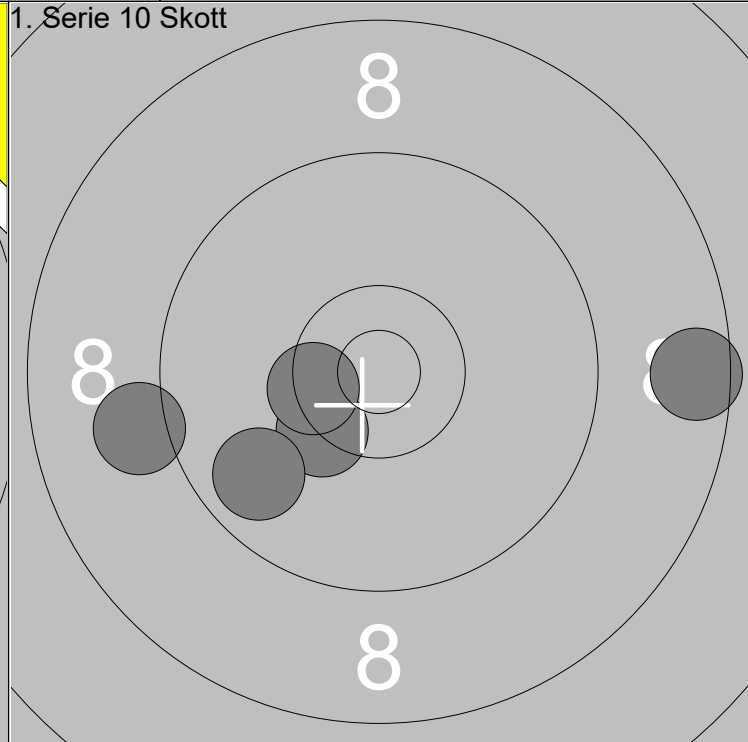
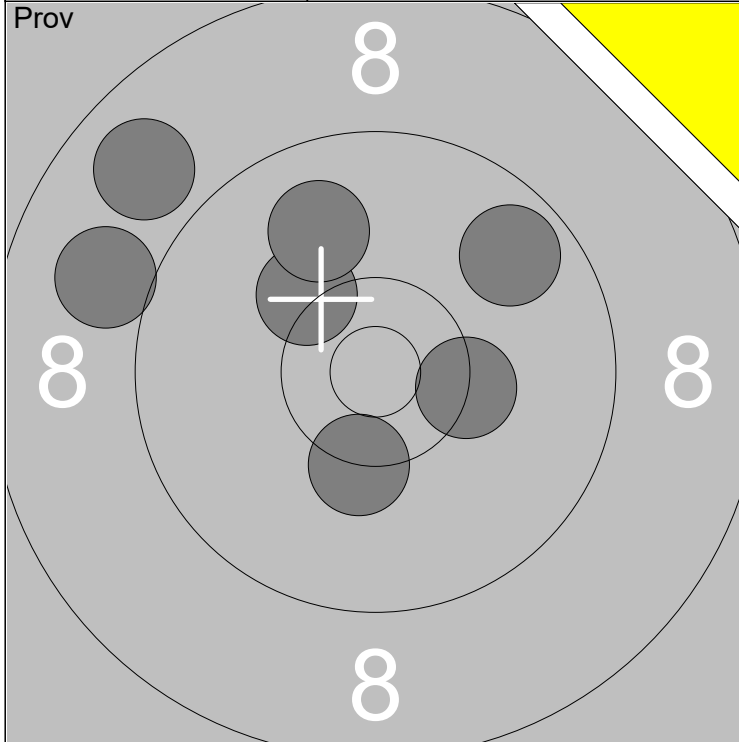

1: 10.3x →	6: 9.7 ↗	Serie	65
2: 10.3x ↓	7: 9.9 ↖		
3: 10.2 ↗		Total	181
4: 8.8 ↗			
5: 9.0 ←			

1: 10.3x ↙	Serie	46
2: 9.1 ←		
3: 8.6 →	Total	227
4: 10.4x ←		
5: 9.8 ↙		

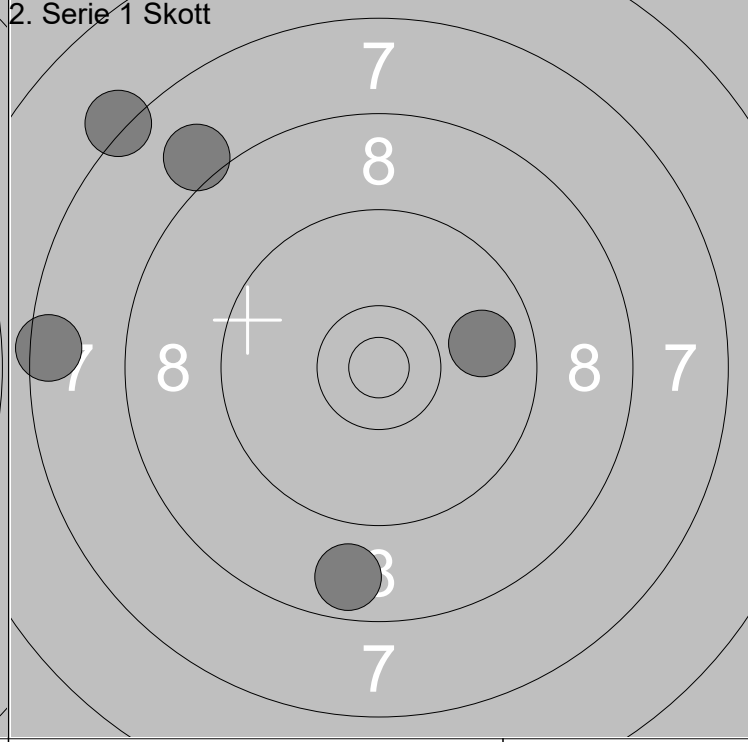
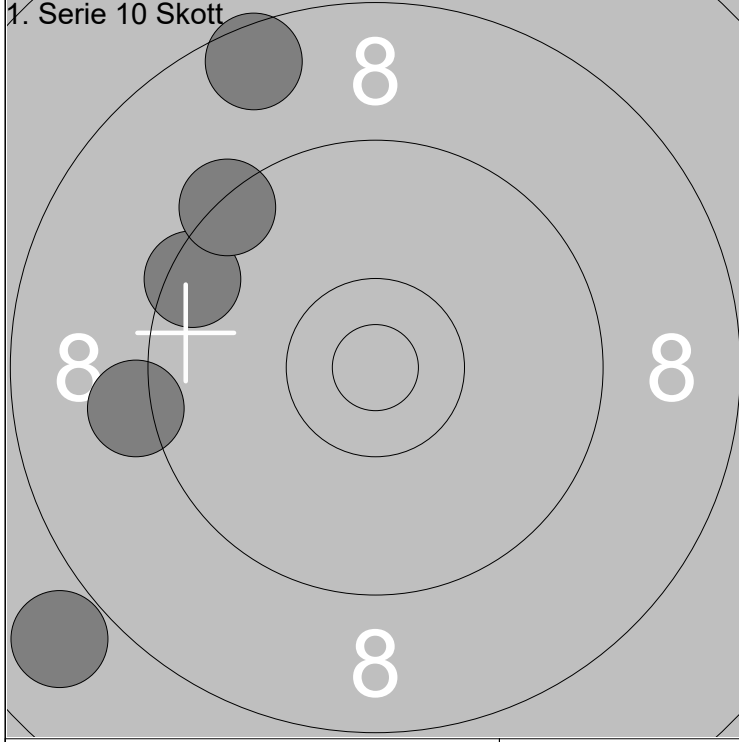

6: 7.9 ↙	Serie	42
7: 9.5 ↖		
8: 9.2 ←	Total	269
9: 8.6 ↗		
10: 9.4 ↗		

1: 9.9 →	Serie	39
2: 7.5 ←		
3: 7.2 ↖	Total	308
4: 8.7 ↓		
5: 8.0 ↖		

	<p>1: 8.6 →</p> <p>2: 10.5x ↗</p> <p>3: 8.8 ↗</p> <p>4: 8.8 →</p> <p>5: 9.3 ↗</p> <p>6: 10.0 ↗</p> <p>7: 9.4 →</p> <p>8: 9.4 ↖</p> <p>9: 10.2 ↓</p> <p>10: 7.8 →</p>		<p>11: 9.1 ↗</p> <p>12: 9.5 ↘</p> <p>13: 10.2 ↗</p>
Serie 88.0		Serie 28.0	
Total 180.0		Total 180.0	

<p>1. Serie 10 Skott</p>	<p>1: 9.3 ↖</p> <p>2: 9.9 →</p> <p>3: 9.7 ↙</p> <p>4: 9.5 ↖</p> <p>5: 10.2 ↓</p>	<p>1. Serie 10 Skott</p>	<p>6: 9.1 ←</p> <p>7: 7.1 ←</p> <p>8: 10.0 ↖</p> <p>9: 9.0 ←</p> <p>10: 8.9 ↗</p>
Serie 46.0		Serie 43.0	
Total 226.0		Total 269.0	

<p>2. Serie 1 Skott</p>	<p>1: 10.6x ➤</p> <p>2: 8.2 ←</p> <p>3: 10.5x ↙</p> <p>4: 10.4x ↙</p> <p>5: 8.7 ←</p>		
Serie 46.0			
Total 315.0			

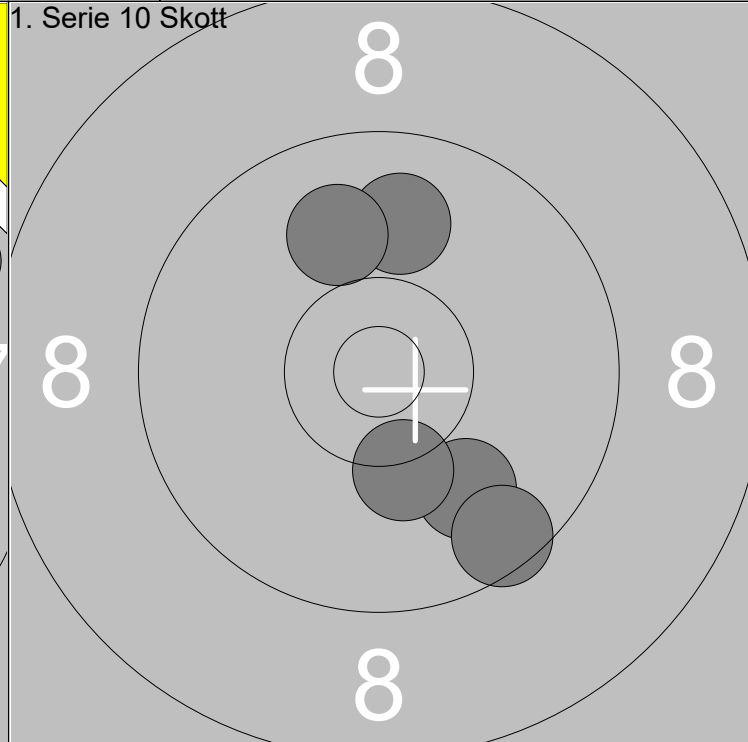
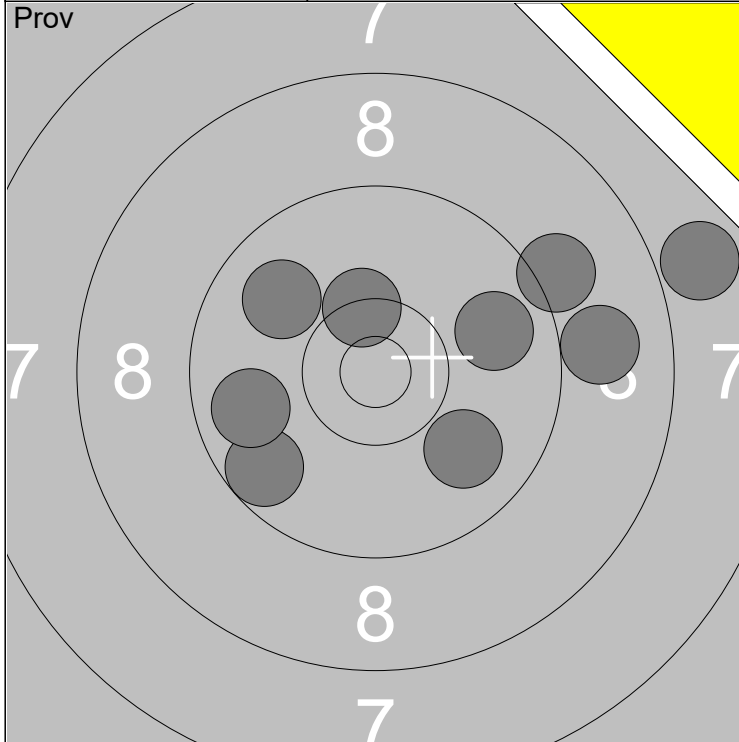

1: 7.9 →	6: 9.8 ←	Serie	79
2: 9.9 ↘	7: 9.9 ↗		
3: 8.9 →	8: 10.4x ↑	Total	179
4: 9.1 ↗	9: 9.8 →		
5: 9.7 ↙			

1: 9.9 ↘	Serie	47
2: 9.9 ↑		
3: 10.3 ↘	Total	226
4: 9.5 ↘		
5: 10.0 ↑		

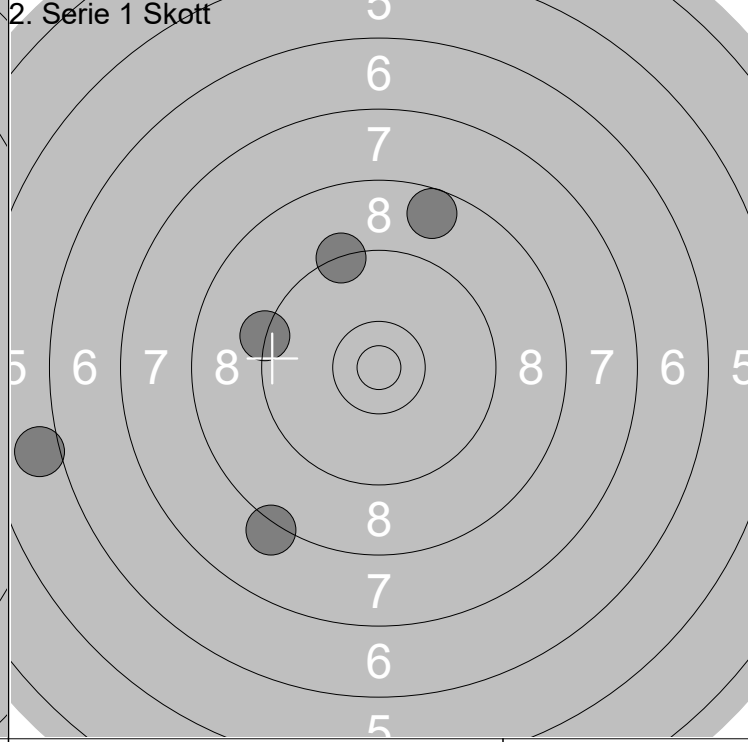
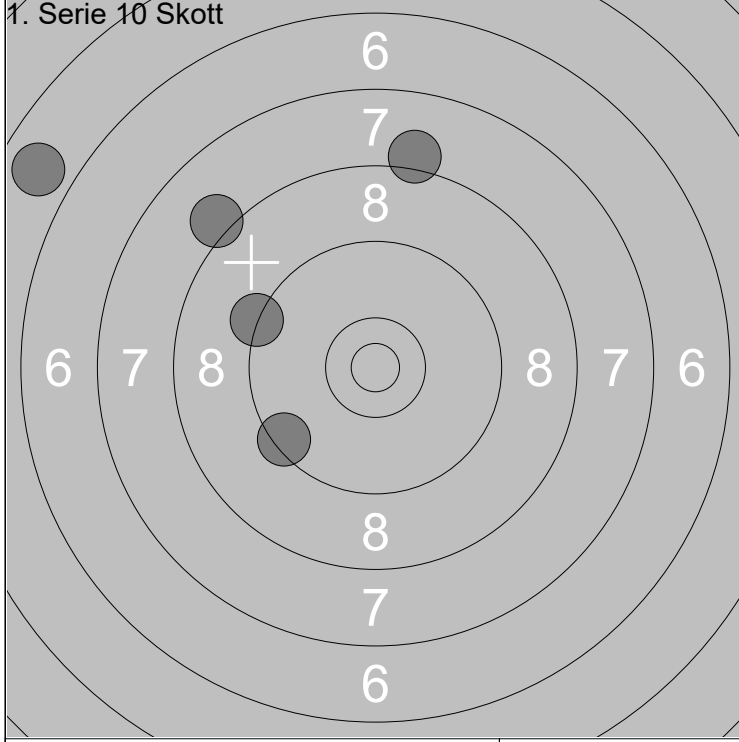

6: 9.4 ↙	Serie	39
7: 5.8 ↗		
8: 9.3 ↗	Total	265
9: 8.1 ↗		
10: 8.1 ↑		

1: 8.2 ↙	Serie	40
2: 6.0 ←		
3: 9.3 ↗	Total	305
4: 8.6 ↑		
5: 9.3 ←		

Prov 	1: 9.5 ← 2: 9.7 ← 3: 10.3 ↗ 4: 10.4x→ 5: 9.9 ↑ 6: 10.2 ↓ 7: 10.5x↘ 8: 9.6 ← 9: 10.2 ↑ 10: 10.3x↗	Prov 	11: 9.4 ↓
Serie 96.0		Serie 9.0	
Total 179.0		Total 179.0	

1. Serie 10 Skott 	1: 10.6x↘ 2: 10.4x→ 3: 10.2 ↑ 4: 10.7x↘ 5: 10.5x↘	1. Serie 10 Skott 	6: 9.4 → 7: 9.4 ↓ 8: 7.3 ← 9: 8.4 ← 10: 10.1 ←
Serie 50.0		Serie 43.0	
Total 229.0		Total 272.0	

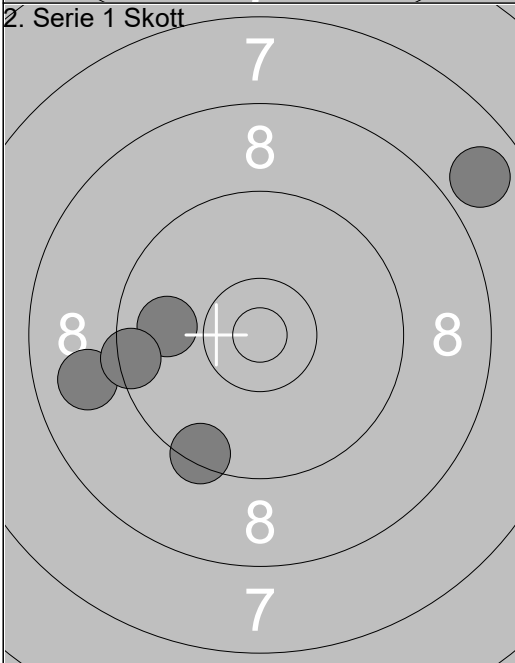
2. Serie 1 Skott 	1: 9.9 ← 2: 8.9 ← 3: 9.4 ← 4: 7.8 ↗ 5: 9.4 ↓		
Serie 42.0			
Total 314.0			

Skjutlag

6

Tavla

23

Jan Wallerström

Ramselefors

Ununge

Vet-S

St

09.07.2024

Tavelträffen Korthåll 2024

Ramselefors SKF

Prov

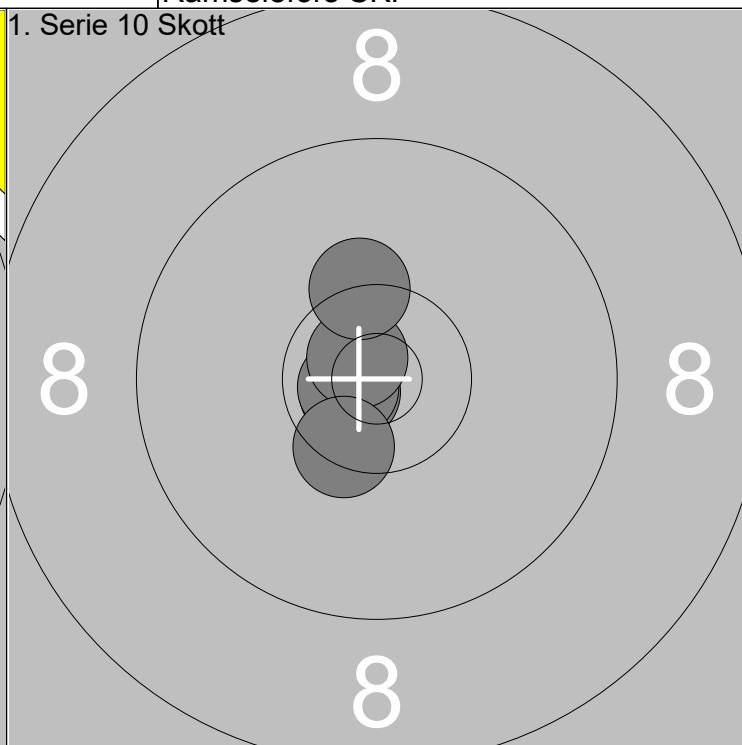

1: 10.2 →
2: 10.3x ←
3: 10.1 →
4: 9.8 →
5: 9.0 ↗

6: 9.3 ←
7: 10.0 →
8: 10.3x ↑
9: 9.0 ↓
10: 10.7x ↘

Serie 96

Total 178

1: 10.7x ←
2: 10.7x ←
3: 10.7x ↖
4: 10.4x ↓
5: 10.3x ↑

Serie 50

Total 228

1. Serie 10 Skott

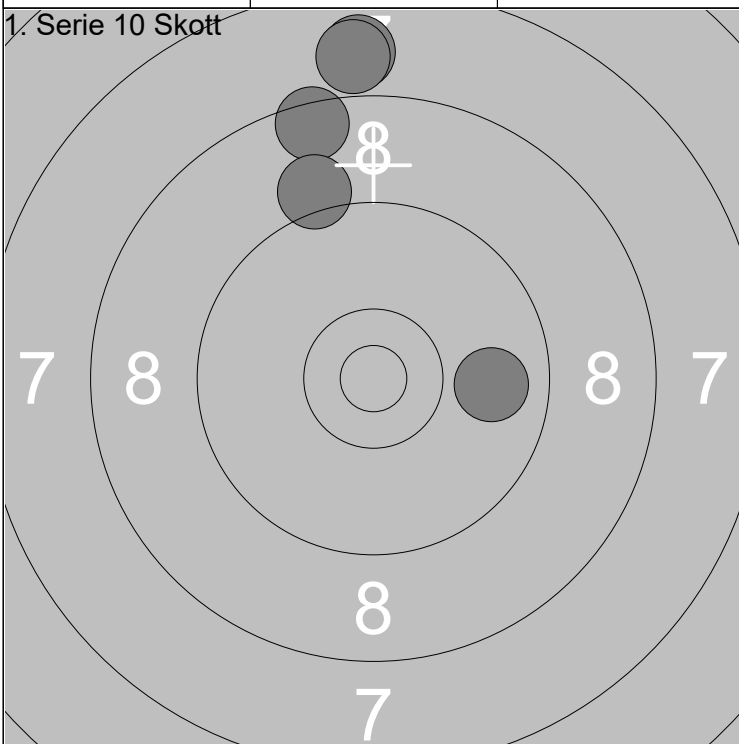

2. Serie 1 Skott

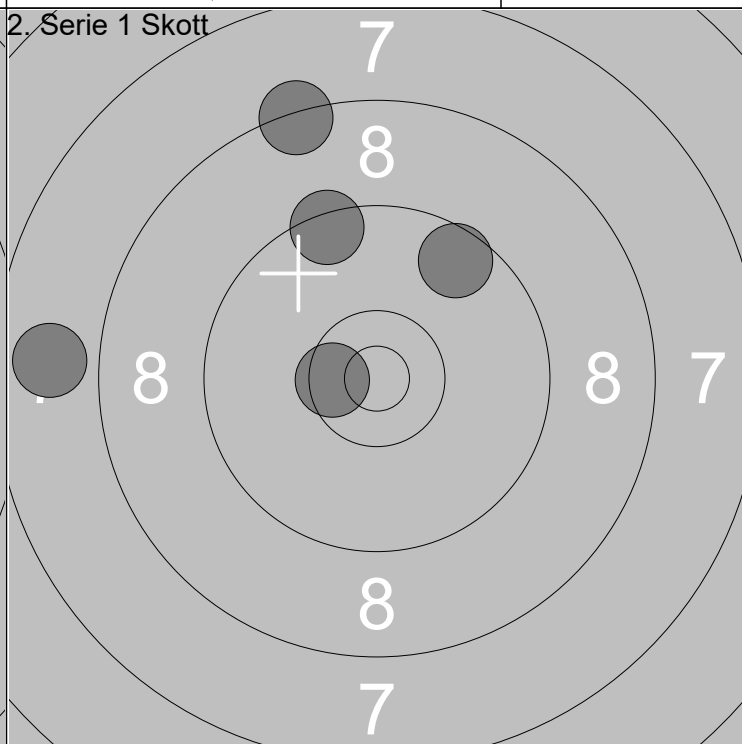

6: 8.5 ↑
7: 9.8 →
8: 7.9 ↑
9: 9.1 ↑
10: 7.9 ↑

Serie 40

Total 268

1: 9.4 ↑
2: 8.4 ↑
3: 9.6 ↗
4: 10.5x ←
5: 7.8 ←

Serie 43

Total 311

	<p>1: 9.7 ↖</p> <p>2: 10.5x↓</p> <p>3: 9.2 ↗</p> <p>4: 10.2 ↑</p> <p>5: 10.0 ↑</p> <p>6: 10.1 ↘</p> <p>7: 10.6x↗</p> <p>8: 10.1 ↖</p> <p>9: 10.1 ↓</p> <p>10: 10.1 ↓</p>	<p>11: 10.9x↖</p> <p>12: 9.8 ↑</p> <p>13: 10.1 ↘</p>
Serie 98.0		Serie 29.0
Total 178.0		Total 178.0

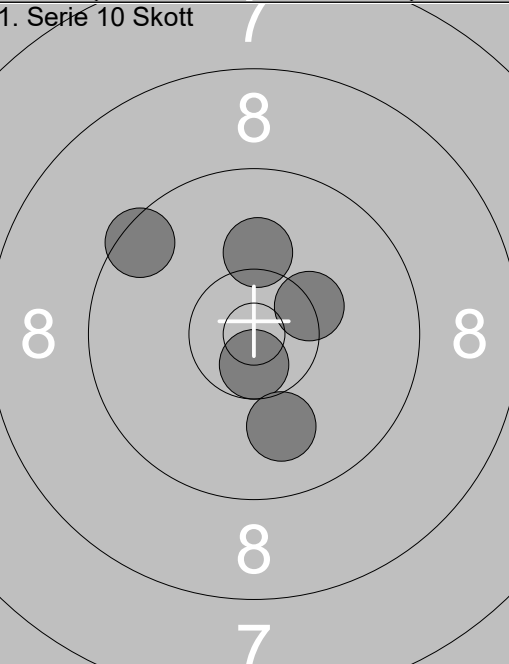
<p>1. Serie 10 Skott</p> 	<p>1: 10.1 ↑</p> <p>2: 9.5 ↖</p> <p>3: 10.3x↗</p> <p>4: 10.6x↓</p> <p>5: 10.0 ↓</p>	<p>6: 7.5 ↓</p> <p>7: 9.7 ↖</p> <p>8: 9.2 ↗</p> <p>9: 9.2 ←</p> <p>10: 10.1 ↑</p>
Serie 49.0		Serie 44.0
Total 227.0		Total 271.0

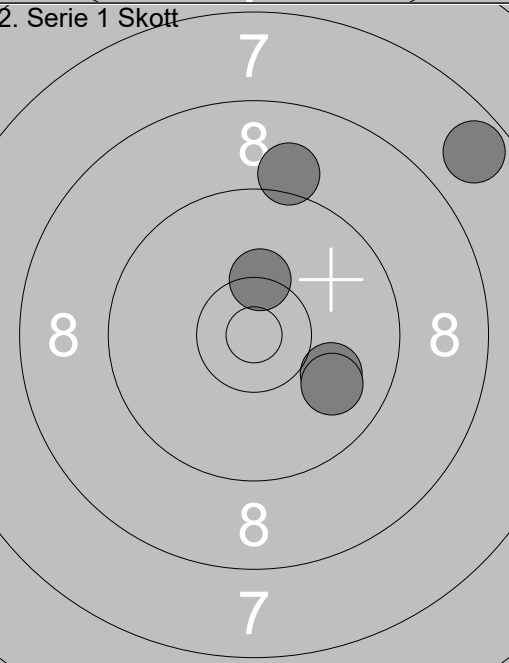
<p>2. Serie 1 Skott</p> 	<p>1: 10.0 ↘</p> <p>2: 9.1 ↑</p> <p>3: 10.3x↑</p> <p>4: 7.7 ↗</p> <p>5: 9.9 ↘</p>	
Serie 45.0		
Total 316.0		