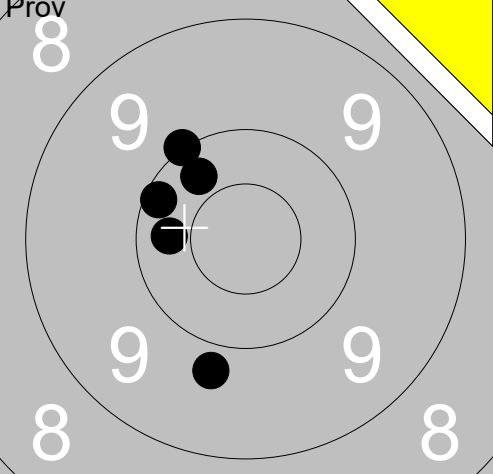
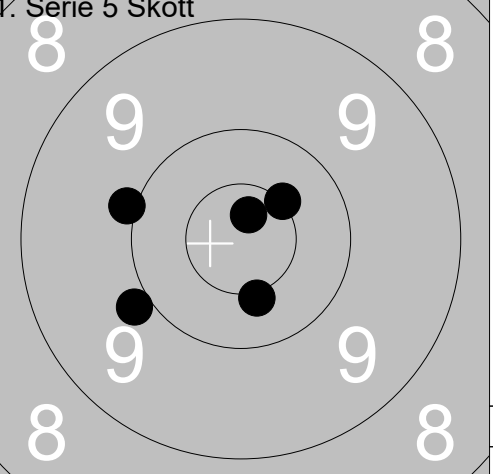
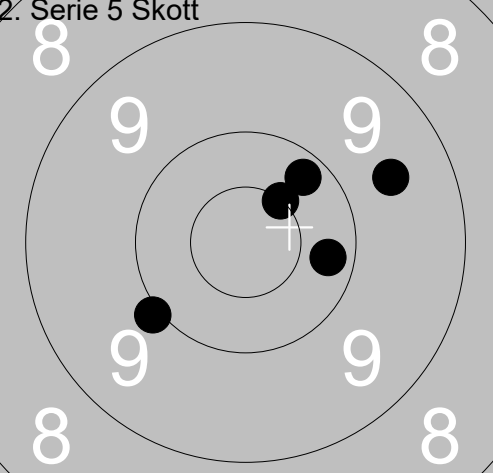
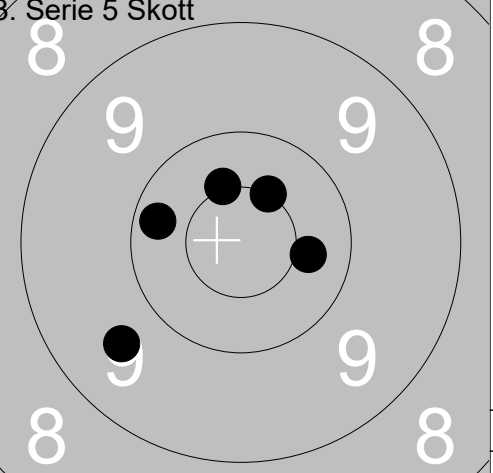
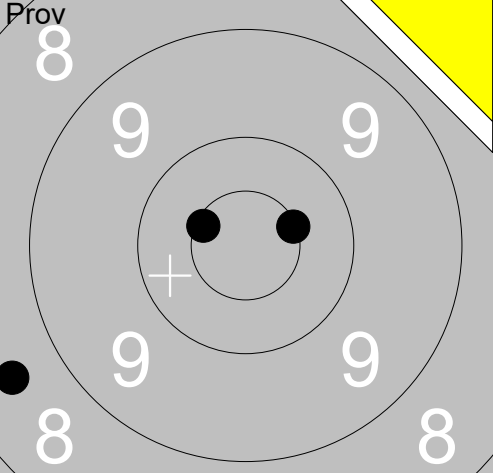
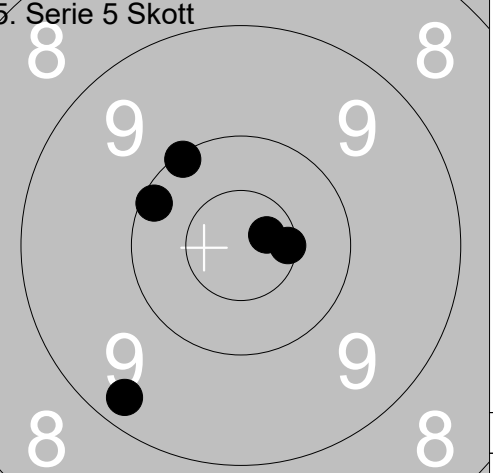
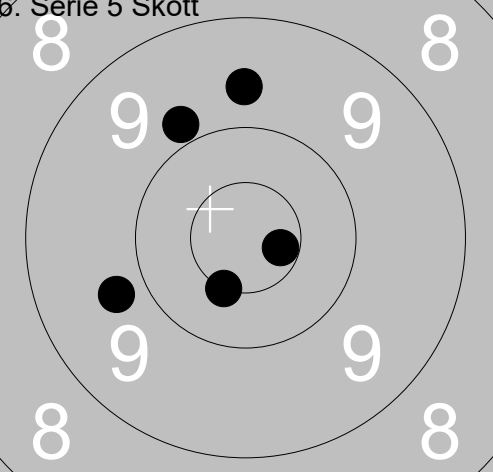
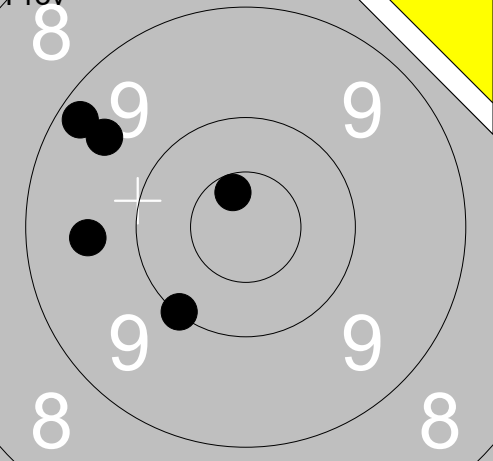
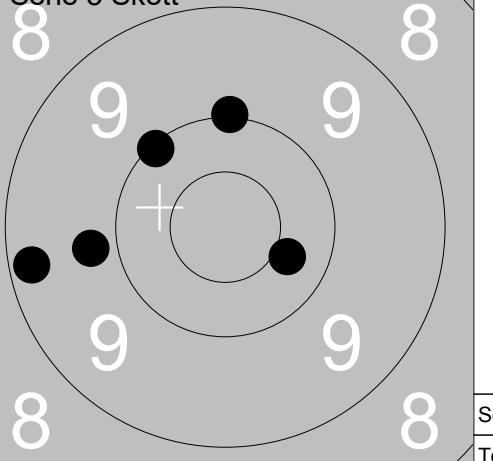
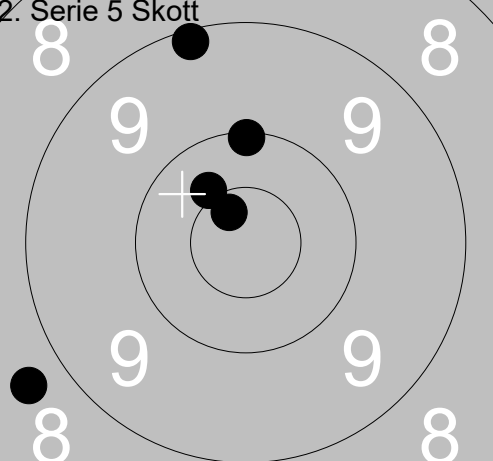
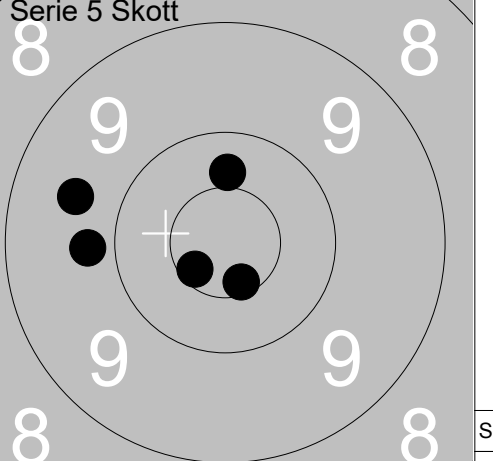
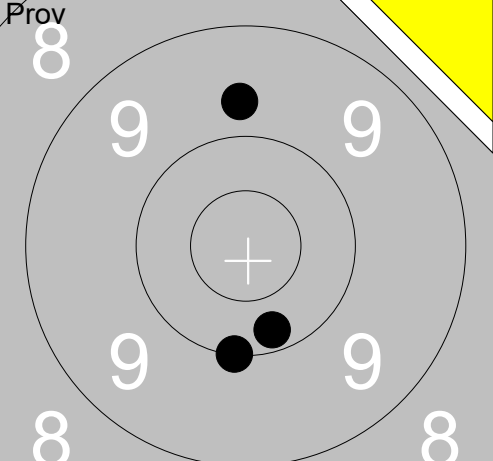
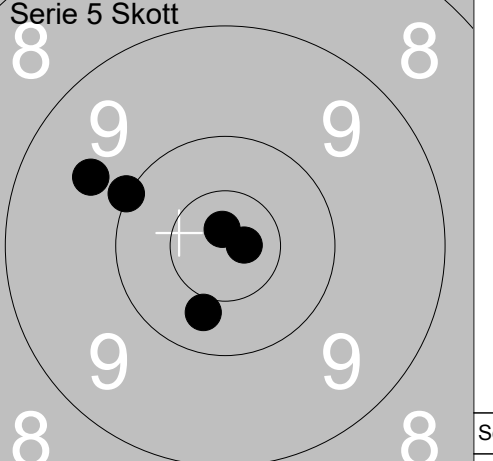
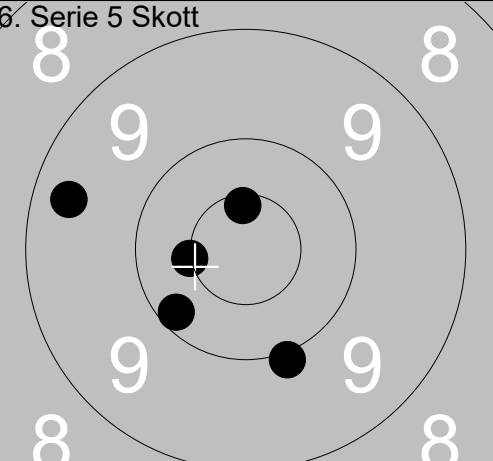

<p>Prov</p>  <p style="text-align: right;">Serie 49.0 Total 0.0</p>	<p>1. Serie 5 Skott</p>  <p style="text-align: right;">Serie 48.0 Total 48.0</p>	<table style="width:100%; border-collapse: collapse;"> <tr><td>1:</td><td>10.0</td><td>↗</td></tr> <tr><td>2:</td><td>10.1</td><td>↖</td></tr> <tr><td>3:</td><td>10.3</td><td>←</td></tr> <tr><td>4:</td><td>10.3</td><td>↗</td></tr> <tr><td>5:</td><td>9.8</td><td>↓</td></tr> </table>	1:	10.0	↗	2:	10.1	↖	3:	10.3	←	4:	10.3	↗	5:	9.8	↓
1:	10.0	↗															
2:	10.1	↖															
3:	10.3	←															
4:	10.3	↗															
5:	9.8	↓															

<p>2. Serie 5 Skott</p>  <p style="text-align: right;">Serie 49.0 Total 97.0</p>	<p>3. Serie 5 Skott</p>  <p style="text-align: right;">Serie 49.0 Total 146.0</p>	<table style="width:100%; border-collapse: collapse;"> <tr><td>1:</td><td>10.5x</td><td>↗</td></tr> <tr><td>2:</td><td>10.2</td><td>→</td></tr> <tr><td>3:</td><td>10.0</td><td>↖</td></tr> <tr><td>4:</td><td>10.2</td><td>↗</td></tr> <tr><td>5:</td><td>9.6</td><td>→</td></tr> </table>	1:	10.5x	↗	2:	10.2	→	3:	10.0	↖	4:	10.2	↗	5:	9.6	→
1:	10.5x	↗															
2:	10.2	→															
3:	10.0	↖															
4:	10.2	↗															
5:	9.6	→															

<p>Prov</p>  <p style="text-align: right;">Serie 28.0 Total 146.0</p>	<p>5. Serie 5 Skott</p>  <p style="text-align: right;">Serie 49.0 Total 195.0</p>	<table style="width:100%; border-collapse: collapse;"> <tr><td>1:</td><td>10.6x</td><td>↖</td></tr> <tr><td>2:</td><td>10.5x</td><td>→</td></tr> <tr><td>3:</td><td>8.6</td><td>←</td></tr> </table>	1:	10.6x	↖	2:	10.5x	→	3:	8.6	←
1:	10.6x	↖									
2:	10.5x	→									
3:	8.6	←									

<p>6. Serie 5 Skott</p>  <p style="text-align: right;">Serie 47.0 Total 242.0</p>		<table style="width:100%; border-collapse: collapse;"> <tr><td>1:</td><td>10.1</td><td>↖</td></tr> <tr><td>2:</td><td>10.7x</td><td>→</td></tr> <tr><td>3:</td><td>9.3</td><td>↖</td></tr> <tr><td>4:</td><td>10.1</td><td>↗</td></tr> <tr><td>5:</td><td>10.6x</td><td>→</td></tr> </table>	1:	10.1	↖	2:	10.7x	→	3:	9.3	↖	4:	10.1	↗	5:	10.6x	→
1:	10.1	↖															
2:	10.7x	→															
3:	9.3	↖															
4:	10.1	↗															
5:	10.6x	→															

<p>Prov</p> 	<p>1: 9.5 ↖ 2: 9.6 ← 3: 9.2 ↗ 4: 10.0 ↘ 5: 10.6x ↑</p>	<p>1. Serie 5 Skott</p> 	<p>1: 10.0 ↑ 2: 9.8 ← 3: 10.4 → 4: 9.2 ← 5: 10.1 ↗</p>
<p>Serie 47.0</p> <p>Total 0.0</p>		<p>Serie 48.0</p> <p>Total 48.0</p>	
<p>2. Serie 5 Skott</p> 	<p>1: 10.1 ↑ 2: 9.1 ↑ 3: 10.4 ↗ 4: 8.7 ↙ 5: 10.7x ↗</p>	<p>3. Serie 5 Skott</p> 	<p>1: 9.8 ← 2: 9.6 ← 3: 10.4 ↑ 4: 10.6x ↓ 5: 10.6x ↙</p>
<p>Serie 47.0</p> <p>Total 95.0</p>		<p>Serie 48.0</p> <p>Total 143.0</p>	
<p>Prov</p> 	<p>1: 10.2 ↓ 2: 9.7 ↑ 3: 10.0 ↓</p>	<p>5. Serie 5 Skott</p> 	<p>1: 10.4 ↓ 2: 9.7 ← 3: 10.8x → 4: 10.8x ↑ 5: 10.0 ↙</p>
<p>Serie 29.0</p> <p>Total 143.0</p>		<p>Serie 49.0</p> <p>Total 192.0</p>	
<p>6. Serie 5 Skott</p> 	<p>1: 10.5x ← 2: 10.0 ↓ 3: 9.4 ← 4: 10.2 ↙ 5: 10.6x ↑</p>		
<p>Serie 49.0</p> <p>Total 241.0</p>			

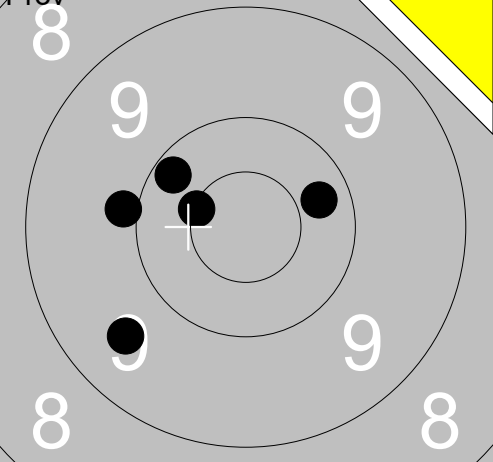
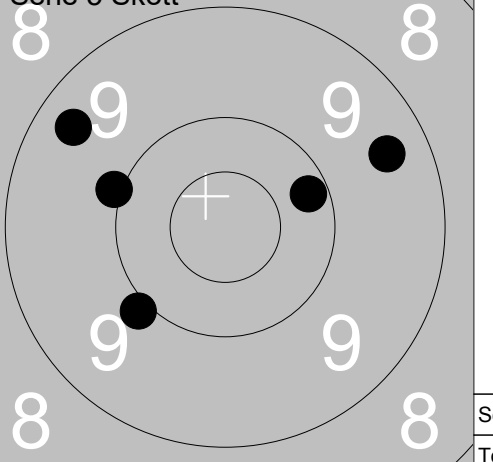
<p>Prov</p> 	<p>1: 10.2 ↖ 2: 9.6 ↙ 3: 9.9 ← 4: 10.3 → 5: 10.5x ↖</p>	<p>1. Serie 5 Skott</p> 	<p>1: 10.0 ↖ 2: 9.4 → 3: 9.4 ↖ 4: 9.9 ↙ 5: 10.2 →</p>
Serie 48.0		Serie 47.0	
Total 0.0		Total 47.0	

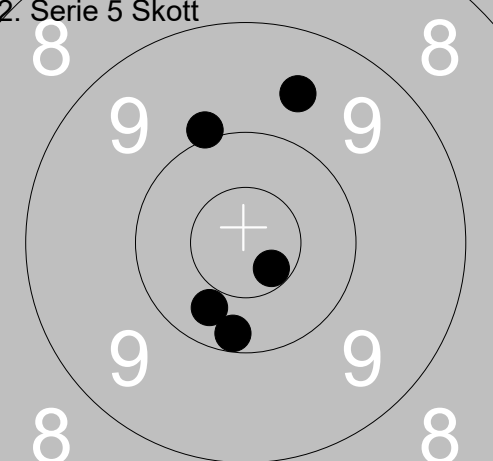
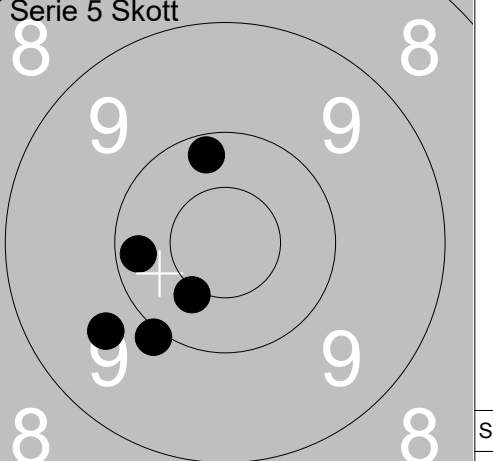
<p>2. Serie 5 Skott</p> 	<p>1: 9.6 ↗ 2: 9.9 ↗ 3: 10.3 ↙ 4: 10.2 ↘ 5: 10.6x ↘</p>	<p>3. Serie 5 Skott</p> 	<p>1: 10.2 ↗ 2: 10.0 ↘ 3: 9.7 ↙ 4: 10.4x ↘ 5: 10.2 ←</p>
Serie 48.0		Serie 49.0	
Total 95.0		Total 144.0	

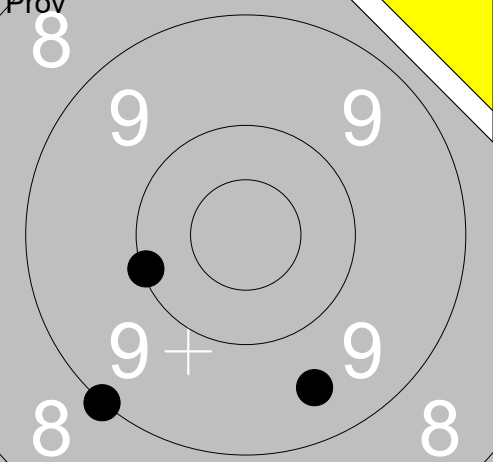
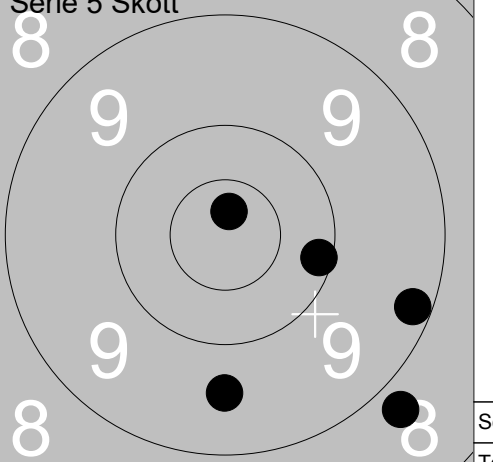
<p>Prov</p> 	<p>1: 10.1 ← 2: 9.0 ↙ 3: 9.5 ↘</p>	<p>5. Serie 5 Skott</p> 	<p>1: 10.8x ↗ 2: 9.2 → 3: 9.6 ↘ 4: 10.1 → 5: 8.8 ↘</p>
Serie 28.0		Serie 46.0	
Total 144.0		Total 190.0	

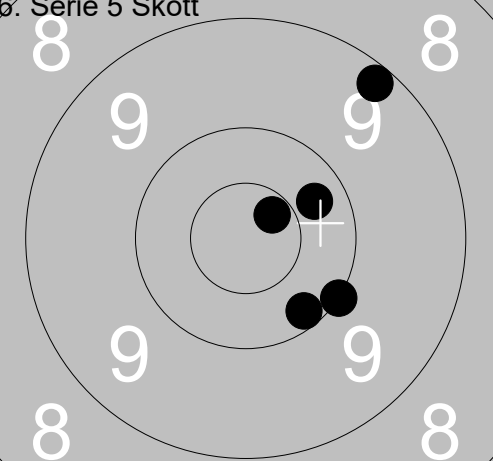
<p>6. Serie 5 Skott</p> 	<p>1: 9.2 ↗ 2: 10.2 ↘ 3: 10.0 ↘ 4: 10.3 → 5: 10.7x ↗</p>		
Serie 49.0			
Total 239.0			

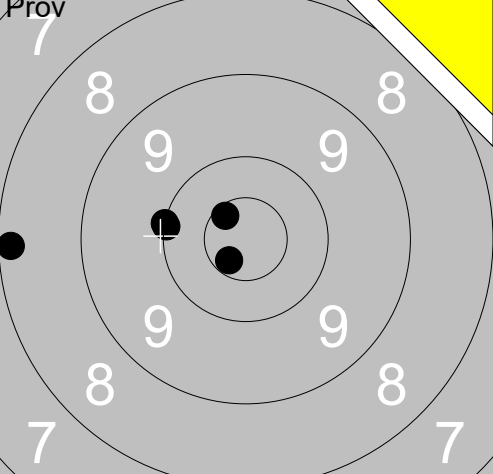
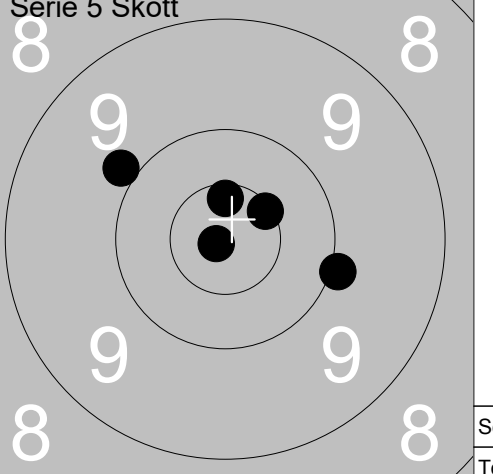
<p>Prov</p> 	<p>1: 8.2 ← 2: 10.6x ↗ 3: 10.6x ↘ 4: 10.0 ← 5: 10.0 ←</p>	<p>1. Serie 5 Skott</p> 	<p>1: 9.9 ↖ 2: 10.0 → 3: 10.6x ↑ 4: 10.9x ← 5: 10.5x ↗</p>
Serie 48.0		Serie 49.0	
Total 0.0		Total 49.0	

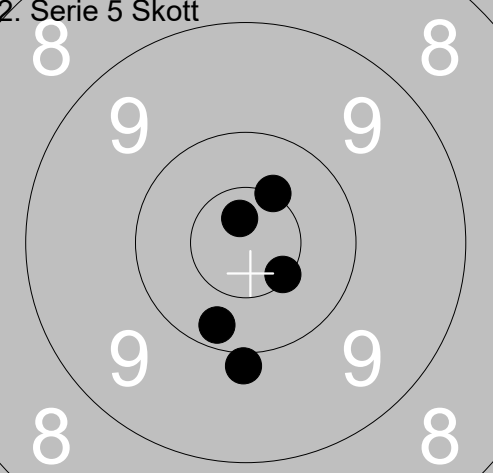
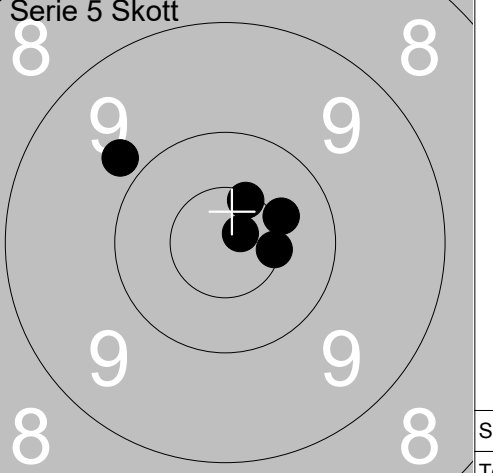
<p>2. Serie 5 Skott</p> 	<p>1: 9.9 ↓ 2: 10.5x ↘ 3: 10.2 ↘ 4: 10.5x ↗ 5: 10.7x ↑</p>	<p>3. Serie 5 Skott</p> 	<p>1: 9.8 ↖ 2: 10.8x ↗ 3: 10.4x ↗ 4: 10.5x → 5: 10.6x ↗</p>
Serie 49.0		Serie 49.0	
Total 98.0		Total 147.0	

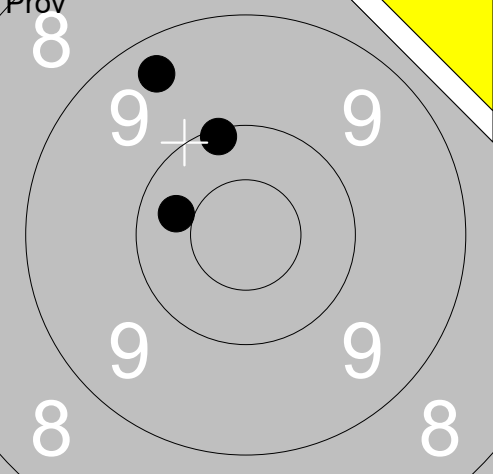
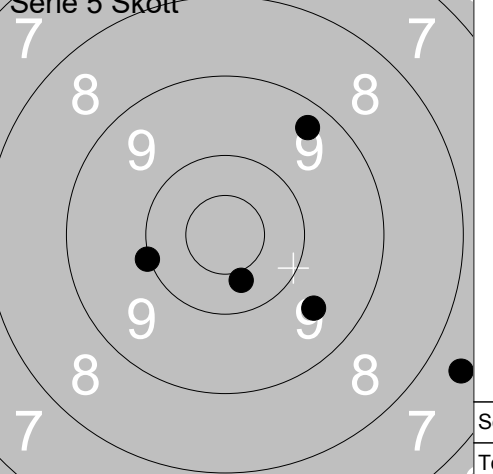
<p>Prov</p> 	<p>1: 9.4 ↗ 2: 10.1 ↑ 3: 10.3 ←</p>	<p>5. Serie 5 Skott</p> 	<p>1: 9.3 ↗ 2: 10.4 ↓ 3: 10.0 ← 4: 9.6 ↓ 5: 7.6 ↓</p>
Serie 29.0		Serie 45.0	
Total 147.0		Total 192.0	

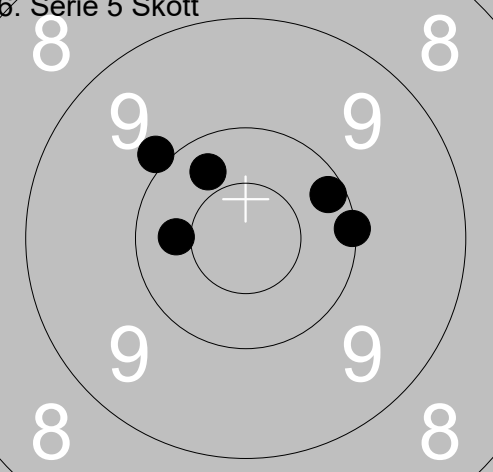
<p>6. Serie 5 Skott</p> 	<p>1: 10.2 ↗ 2: 10.1 → 3: 10.3 ↗ 4: 9.9 ↗ 5: 10.4 ←</p>		
Serie 49.0			
Total 241.0			

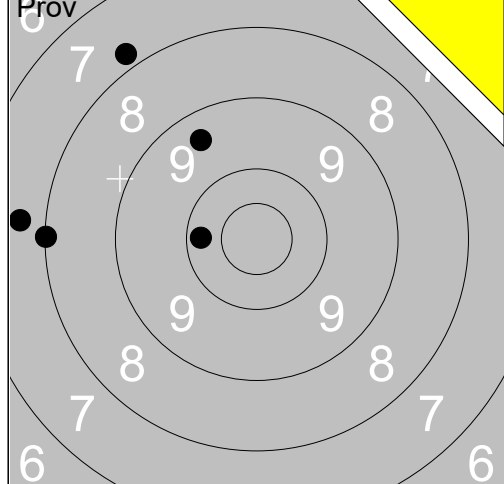

1:	9.4	↗
2:	7.7	←
3:	7.8	↗
4:	8.0	←
5:	10.2	←

Serie	41.0
Total	0.0

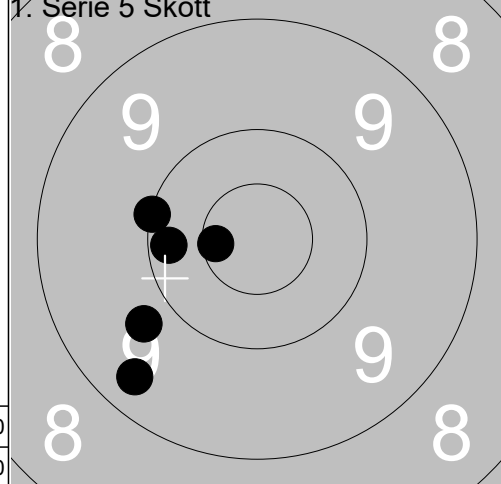

1:	10.6x	←
2:	9.7	↙
3:	9.4	↘
4:	10.0	←
5:	10.2	←

Serie	48.0
Total	48.0

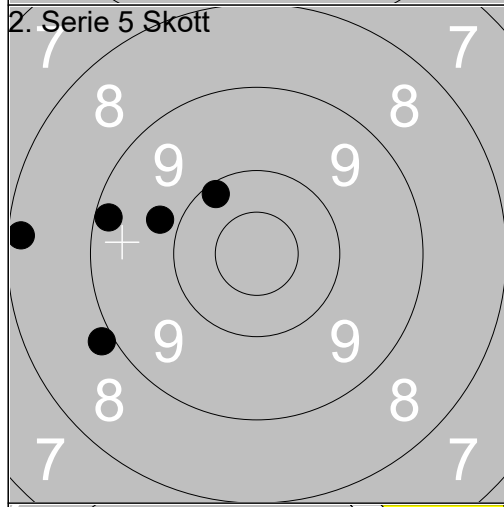

1:	10.1	↗
2:	9.8	↙
3:	9.2	↙
4:	8.2	←
5:	8.9	↙

Serie	44.0
Total	92.0

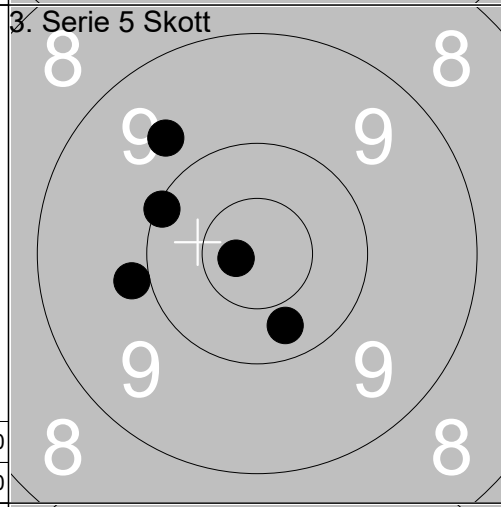

1:	10.1	↙
2:	9.7	↗
3:	10.3	↘
4:	10.8x	←
5:	9.9	←

Serie	48.0
Total	140.0

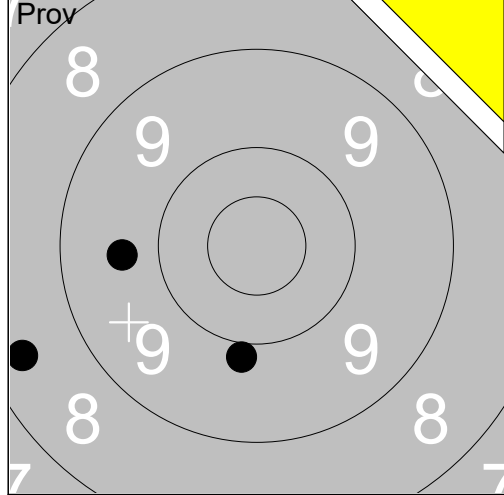

1:	9.7	←
2:	9.9	↓
3:	8.4	←

Serie	26.0
Total	140.0

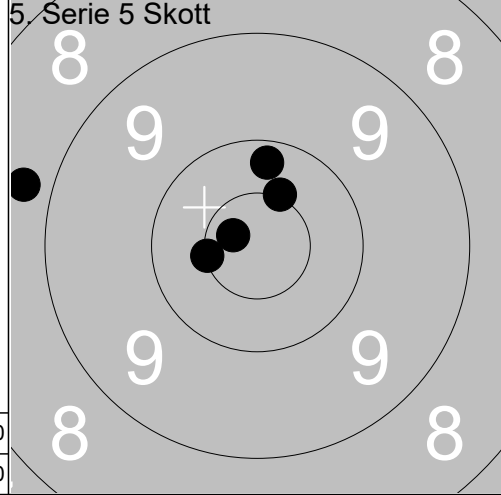

1:	10.7x	↙
2:	8.8	←
3:	10.5x	←
4:	10.5x	↗
5:	10.2	↑

Serie	48.0
Total	188.0

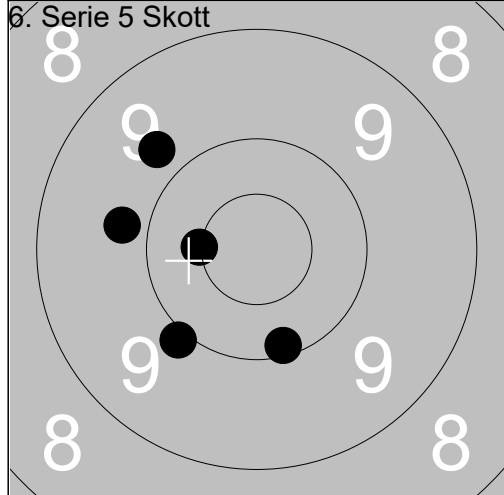

1:	10.1	↓
2:	9.8	↗
3:	10.5x	←
4:	9.9	↘
5:	9.8	←

Serie	47.0
Total	235.0

<p>Prov</p>	<p>1: 9.6 ↑ 2: 10.5x ↗ 3: 10.6x ← 4: 9.7 ← 5: 8.3 ←</p> <p>Serie 46.0 Total 0.0</p>	<p>1. Serie 5 Skott</p>	<p>1: 9.7 ← 2: 10.4 ← 3: 9.6 ← 4: 10.0 ↘ 5: 9.1 ↗</p> <p>Serie 47.0 Total 47.0</p>
-------------	---	-------------------------	--

<p>2. Serie 5 Skott</p>	<p>1: 10.0 ← 2: 10.0 ← 3: 10.0 ↗ 4: 10.0 ↗ 5: 8.9 ↓</p> <p>Serie 48.0 Total 95.0</p>	<p>3. Serie 5 Skott</p>	<p>1: 10.8x ↓ 2: 10.3 ← 3: 9.2 ↑ 4: 9.9 ↑ 5: 8.5 ↗</p> <p>Serie 46.0 Total 141.0</p>
-------------------------	--	-------------------------	--

<p>Prov</p>	<p>1: 9.3 ↑ 2: 9.8 ↑ 3: 9.8 →</p> <p>Serie 27.0 Total 141.0</p>	<p>5. Serie 5 Skott</p>	<p>1: 9.5 ↑ 2: 10.4 ← 3: 10.8x ↑ 4: 8.9 → 5: 9.0 ←</p> <p>Serie 46.0 Total 187.0</p>
-------------	---	-------------------------	--

<p>6. Serie 5 Skott</p>	<p>1: 9.8 ↖ 2: 9.0 ↓ 3: 9.5 ↓ 4: 10.1 ↓ 5: 9.4 ←</p> <p>Serie 46.0 Total 233.0</p>		
-------------------------	--	--	--

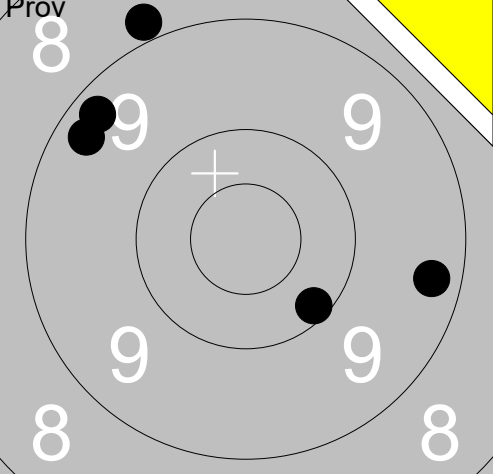
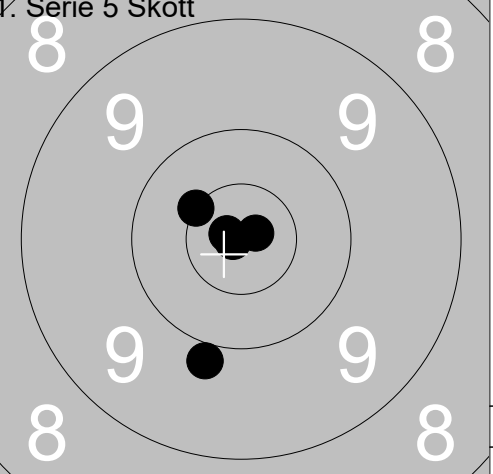
<p>Prov</p> 	<p>1: 9.3 ↗ 2: 9.3 ↗ 3: 10.1 ↘ 4: 8.8 ↗ 5: 9.3 →</p> <p>Serie 45.0 Total 0.0</p>	<p>1. Serie 5 Skott</p> 	<p>1: 10.8x → 2: 10.5x ↖ 3: 9.9 ↓ 4: 10.8x ↖ 5: 10.9x ←</p> <p>Serie 49.0 Total 49.0</p>
--	--	--	--

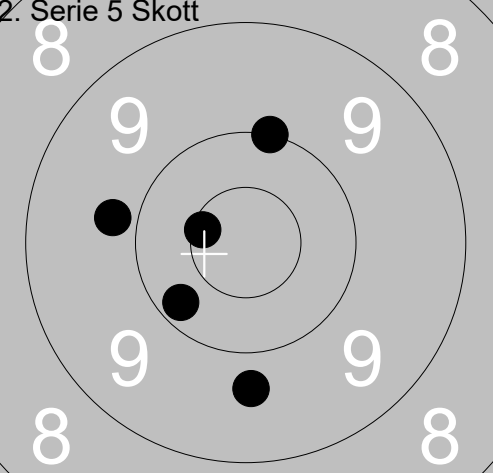
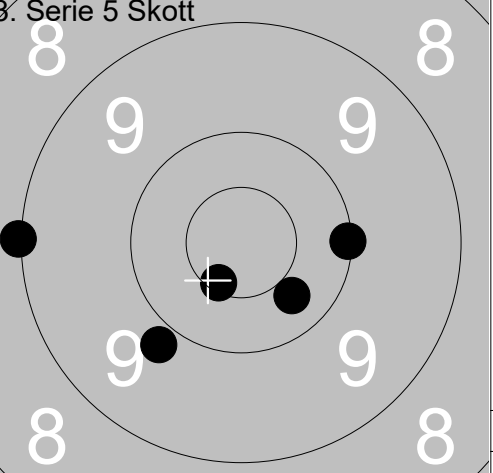
<p>2. Serie 5 Skott</p> 	<p>1: 10.6x ← 2: 9.7 ↓ 3: 10.0 ↑ 4: 9.8 ← 5: 10.2 ↙</p> <p>Serie 48.0 Total 97.0</p>	<p>3. Serie 5 Skott</p> 	<p>1: 10.3 ↘ 2: 10.1 → 3: 9.0 ← 4: 9.8 ↘ 5: 10.6x ↘</p> <p>Serie 48.0 Total 145.0</p>
---	--	---	---

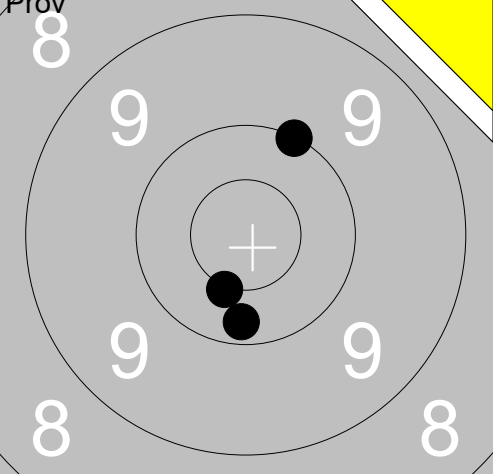
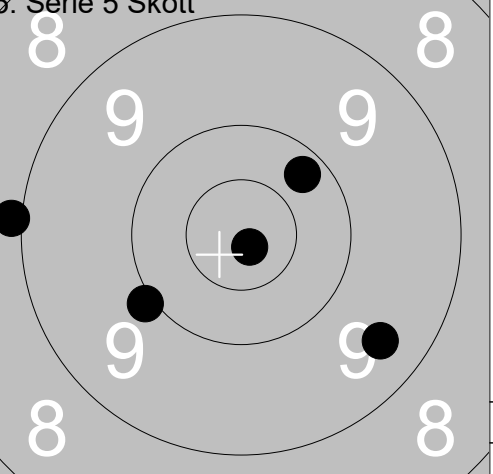
<p>Prov</p> 	<p>1: 10.2 ↓ 2: 10.5x ↓ 3: 10.0 ↑</p> <p>Serie 30.0 Total 145.0</p>	<p>5. Serie 5 Skott</p> 	<p>1: 10.2 ↗ 2: 10.8x ↓ 3: 9.4 ↘ 4: 8.9 ← 5: 10.0 ↙</p> <p>Serie 47.0 Total 192.0</p>
--	---	--	---

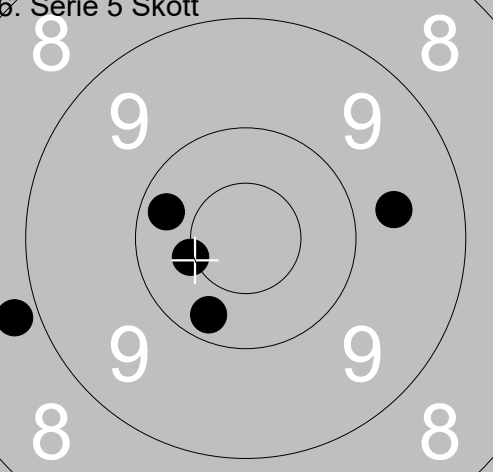
<p>6. Serie 5 Skott</p> 	<p>1: 9.7 → 2: 10.2 ↖ 3: 8.8 ← 4: 10.2 ↘ 5: 10.5x ←</p> <p>Serie 47.0 Total 239.0</p>		
--	---	--	--

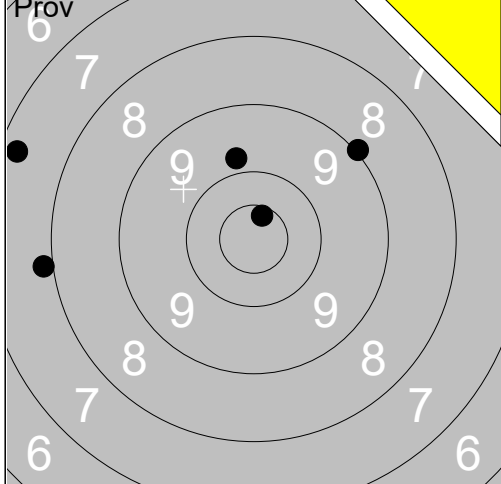

1:	7.9	←
2:	7.3	←
3:	10.6x	↑
4:	9.8	↑
5:	9.0	↗
Serie		42.0
Total		0.0

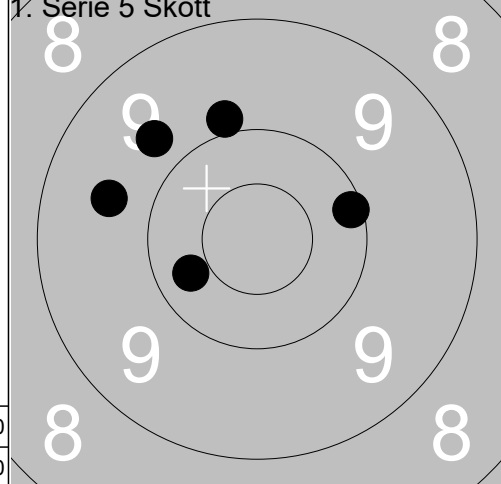

1:	10.1	→
2:	9.9	↑
3:	9.6	←
4:	9.7	↗
5:	10.3	←
Serie		47.0
Total		47.0

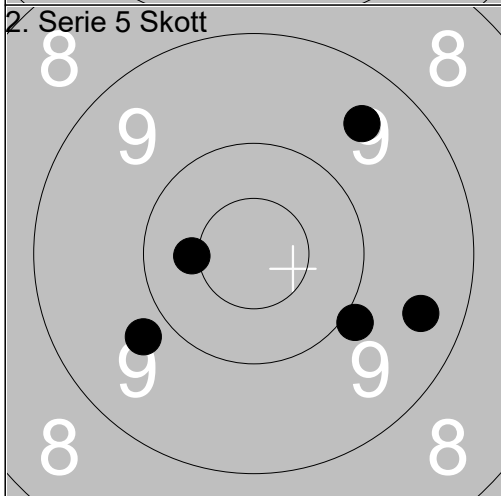

1:	9.4	→
2:	9.9	→
3:	10.4x	←
4:	9.5	↗
5:	9.8	←
Serie		46.0
Total		93.0

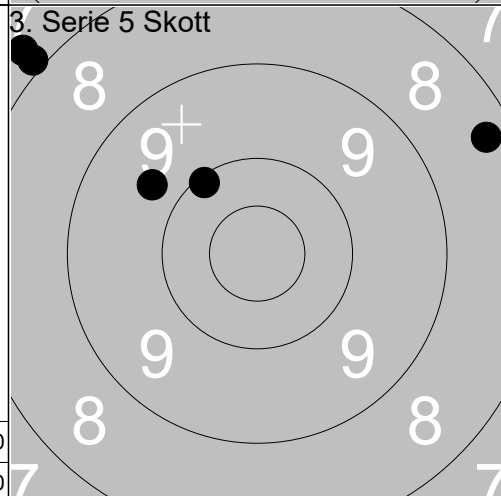

1:	10.1	↖
2:	8.3	→
3:	9.7	↖
4:	7.8	↗
5:	7.9	↗
Serie		41.0
Total		134.0

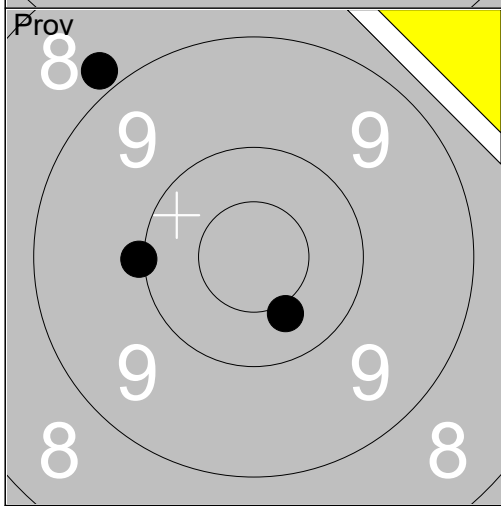

1:	10.0	←
2:	10.4	↘
3:	8.8	↗
Serie		28.0
Total		134.0

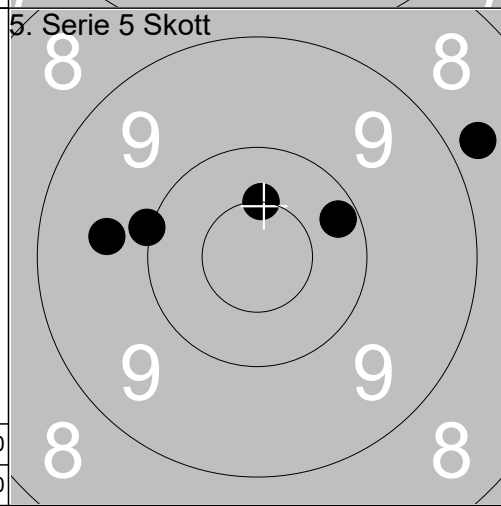

1:	10.0	←
2:	9.6	←
3:	10.2	→
4:	10.5x	↑
5:	8.8	↗
Serie		47.0
Total		181.0

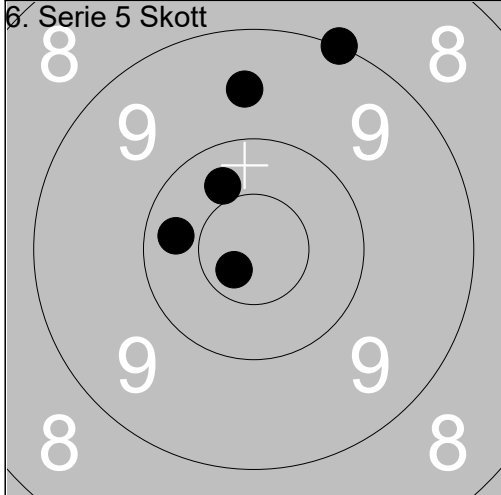

1:	10.4	↗
2:	10.7x	↘
3:	9.0	↗
4:	9.6	↑
5:	10.3	←
Serie		48.0
Total		229.0

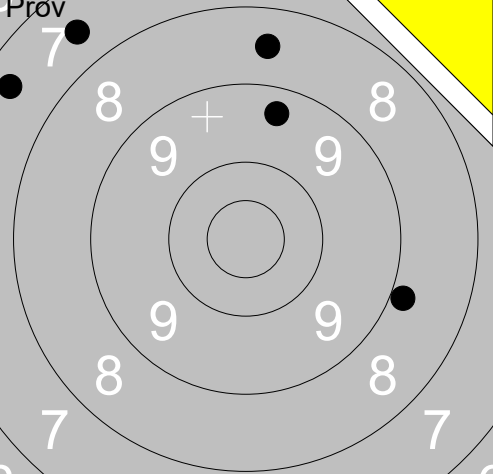
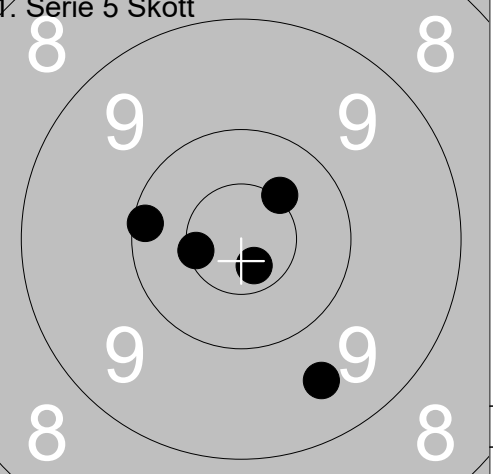

<p>Prov</p> 	<p>1: 8.5 ↑</p> <p>2: 7.4 ↗</p> <p>3: 7.6 ↗</p> <p>4: 9.4 ↑</p> <p>5: 8.9 ↘</p>	<p>1. Serie 5 Skott</p> 	<p>1: 10.6x ←</p> <p>2: 10.5x ↗</p> <p>3: 10.7x ↓</p> <p>4: 10.1 ←</p> <p>5: 9.6 ↓</p>
Serie 39.0		Serie 49.0	
Total 0.0		Total 49.0	

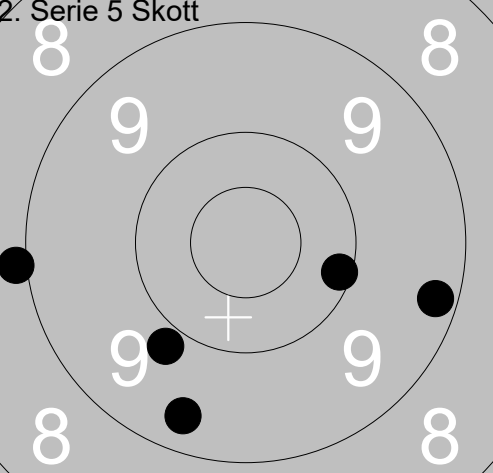
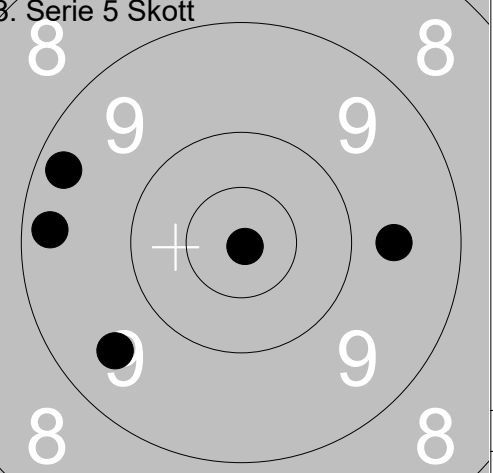
<p>2. Serie 5 Skott</p> 	<p>1: 10.1 →</p> <p>2: 8.9 ←</p> <p>3: 9.2 →</p> <p>4: 9.8 ↓</p> <p>5: 9.4 ↓</p>	<p>3. Serie 5 Skott</p> 	<p>1: 9.6 →</p> <p>2: 9.5 ↘</p> <p>3: 9.3 ↗</p> <p>4: 9.3 ←</p> <p>5: 10.9x ↓</p>
Serie 45.0		Serie 46.0	
Total 94.0		Total 140.0	

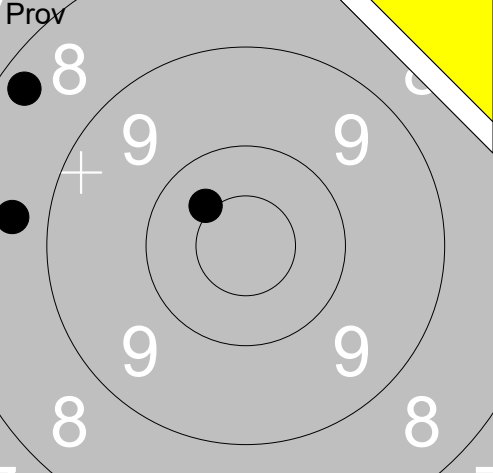
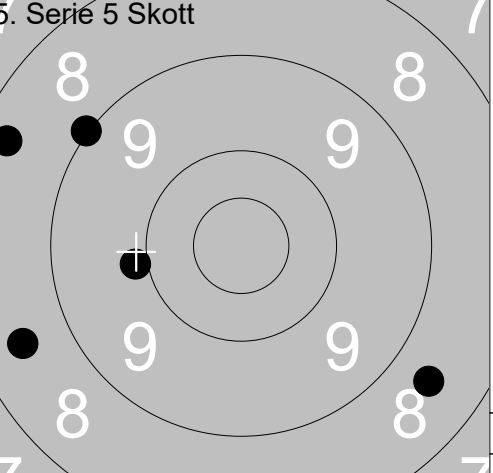
<p>Prov</p> 	<p>1: 8.7 ←</p> <p>2: 10.4x ↗</p> <p>3: 8.3 ↗</p>	<p>5. Serie 5 Skott</p> 	<p>1: 8.6 ↘</p> <p>2: 8.3 ↗</p> <p>3: 8.5 ←</p> <p>4: 9.0 ↗</p> <p>5: 9.9 ←</p>
Serie 26.0		Serie 42.0	
Total 140.0		Total 182.0	

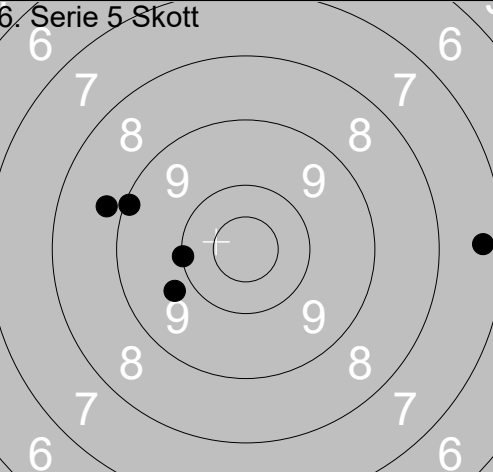
<p>6. Serie 5 Skott</p> 	<p>1: 10.0 ←</p> <p>2: 7.4 →</p> <p>3: 9.8 ←</p> <p>4: 8.8 ←</p> <p>5: 9.1 ↗</p>		
Serie 43.0			
Total 225.0			

<p>Prov</p>	<p>1. Serie 5 Skott</p>	
1: 9.8 ← 2: 8.6 ← 3: 8.4 ↗ 4: 9.4 ← 5: 9.9 ←	1: 10.0 ↖ 2: 10.1 ← 3: 8.8 ↗ 4: 10.2 ↗ 5: 9.7 ↗	
Serie 43.0 Total 0.0	Serie 47.0 Total 47.0	

<p>2. Serie 5 Skott</p>	<p>3. Serie 5 Skott</p>	
1: 10.1 ↑ 2: 10.0 → 3: 9.6 ↗ 4: 9.8 ← 5: 10.8x ←	1: 10.2 ↓ 2: 10.2 ← 3: 10.0 ↗ 4: 10.4x ↗ 5: 8.9 ↖	
Serie 48.0 Total 95.0	Serie 48.0 Total 143.0	

<p>Prov</p>	<p>5. Serie 5 Skott</p>	
1: 8.9 ↓ 2: 10.0 ↖ 3: 8.9 ↑	1: 10.2 ↖ 2: 10.7x ← 3: 10.1 ↓ 4: 10.3 ← 5: 9.1 ↗	
Serie 26.0 Total 143.0	Serie 49.0 Total 192.0	

<p>6. Serie 5 Skott</p>		
1: 9.6 ↓ 2: 10.4x ↗ 3: 10.2 → 4: 10.8x ↘ 5: 10.8x ↗		
Serie 49.0 Total 241.0		

Skjutlag

Tavla

1

19

Emma Eriksson

Ramselefors

Ramselefors

D

Vb

07.07.2024

Tavelträffen A 2024

Ramselefors SKF

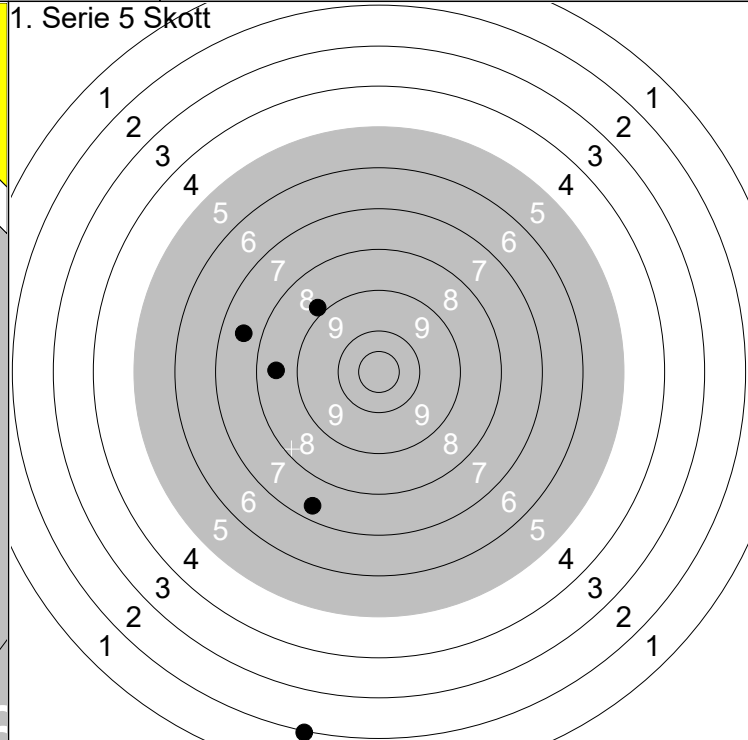
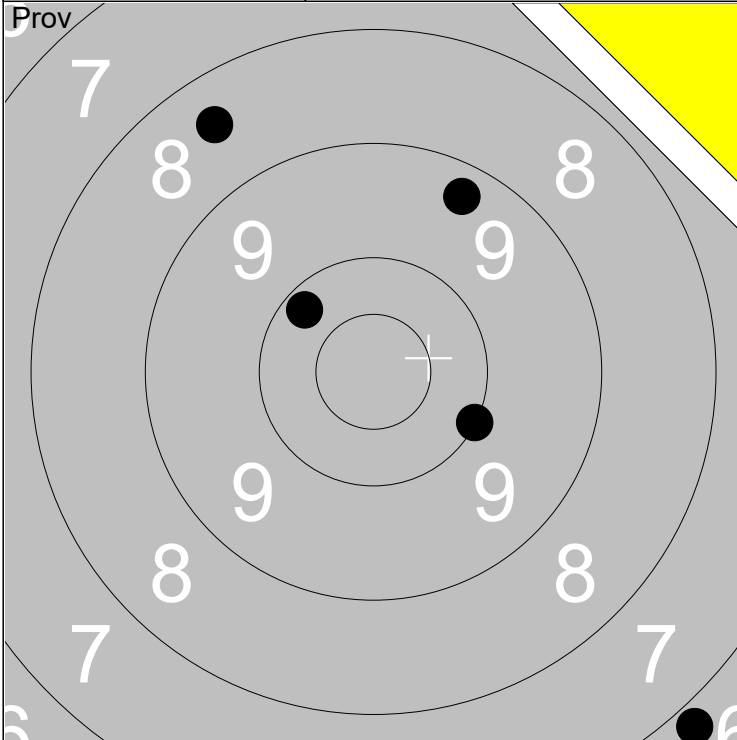

1:	10.2	↗
2:	9.3	↗
3:	10.0	↘
4:	8.5	↗
5:	6.8	↘

Serie	43
Total	0

1:	8.9	↗
2:	7.6	↖
3:	2.0	↘
4:	8.5	↖
5:	7.4	↘

Serie	32
Total	32

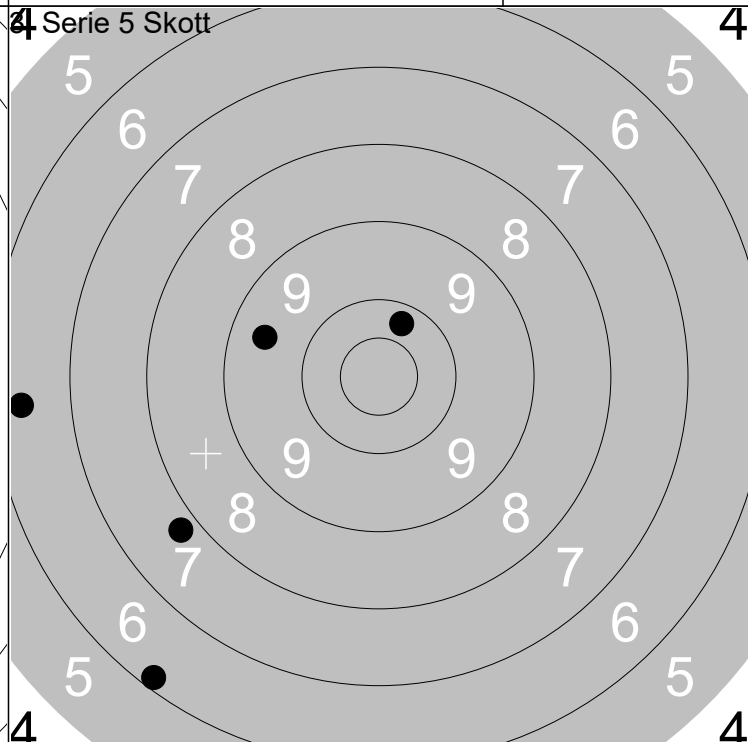
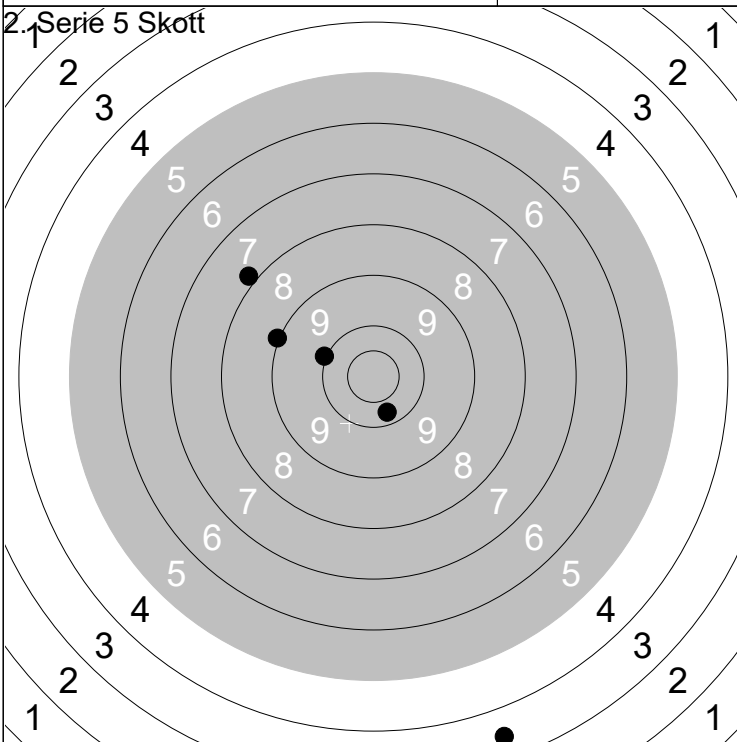



1:	10.3	↘
2:	7.9	↗
3:	10.0	↗
4:	9.0	↗
5:	3.5	↘

Serie	39
Total	71

1:	10.3	↗
2:	6.4	↖
3:	7.8	↘
4:	9.5	↖
5:	6.2	↘

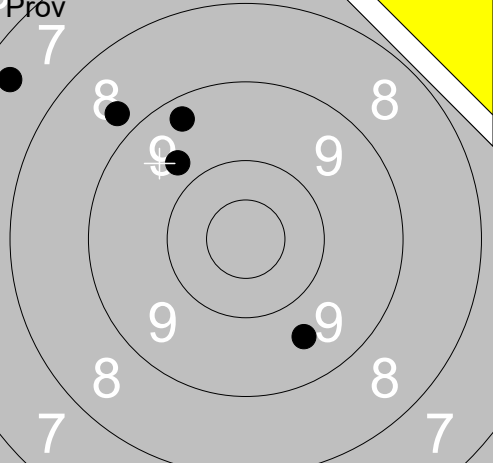
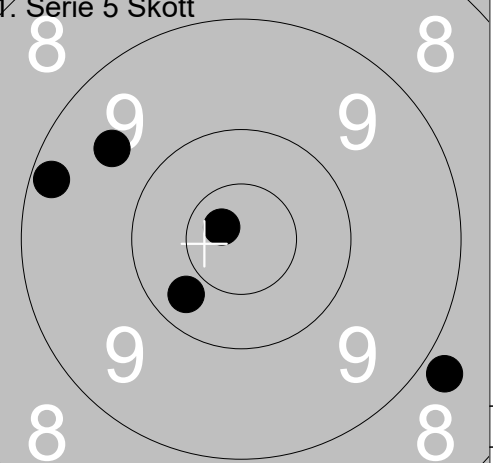
Serie	38
Total	109

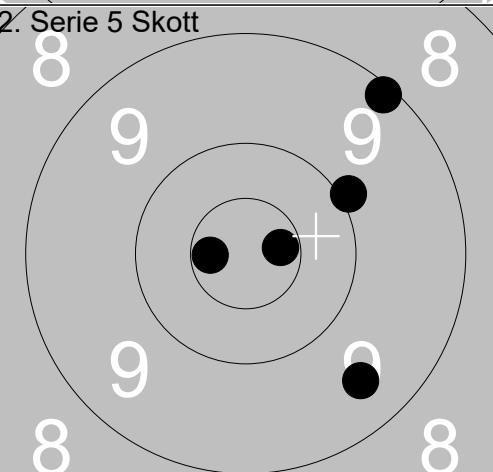
<p>Prov</p> 	<p>1: 8.7 ↗ 2: 7.4 ↗ 3: 9.7 ↗ 4: 9.6 ↘ 5: 9.3 ↗</p>	<p>1. Serie 5 Skott</p> 	<p>1: 10.8x ↗ 2: 10.3 ↘ 3: 9.2 ← 4: 8.8 ↘ 5: 9.6 ↗</p>
Serie 42.0		Serie 46.0	
Total 0.0		Total 46.0	

<p>2. Serie 5 Skott</p> 	<p>1: 10.7x → 2: 10.6x ← 3: 9.5 ↘ 4: 9.1 ↗ 5: 10.0 ↗</p>	<p>3. Serie 5 Skott</p> 	<p>1: 9.8 ↓ 2: 10.1 ↘ 3: 10.6x ← 4: 9.7 → 5: 9.6 ↘</p>
Serie 48.0		Serie 47.0	
Total 94.0		Total 141.0	

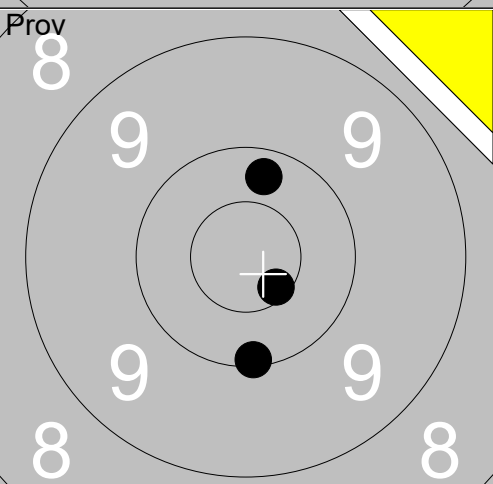
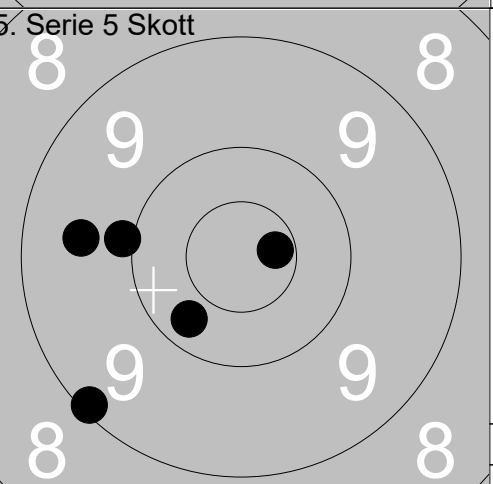
<p>Prov</p> 	<p>1: 10.3 ↑ 2: 10.1 ↓ 3: 10.6x ↘</p>	<p>5. Serie 5 Skott</p> 	<p>1: 10.3 ↘ 2: 10.7x → 3: 9.9 ← 4: 9.6 ← 5: 9.1 ↘</p>
Serie 30.0		Serie 47.0	
Total 141.0		Total 188.0	

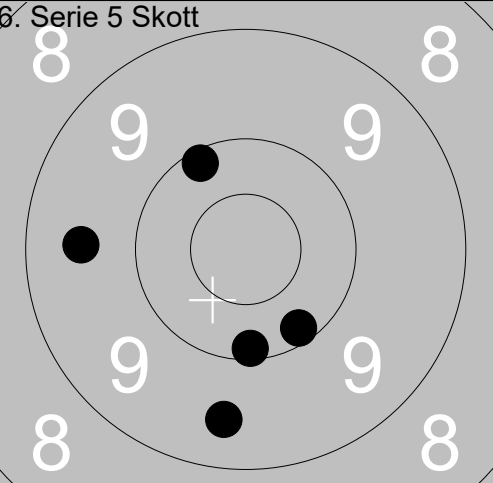
<p>6. Serie 5 Skott</p> 	<p>1: 10.2 ↓ 2: 10.1 ↓ 3: 9.5 ← 4: 9.5 ↓ 5: 10.1 ↗</p>		
Serie 48.0			
Total 236.0			

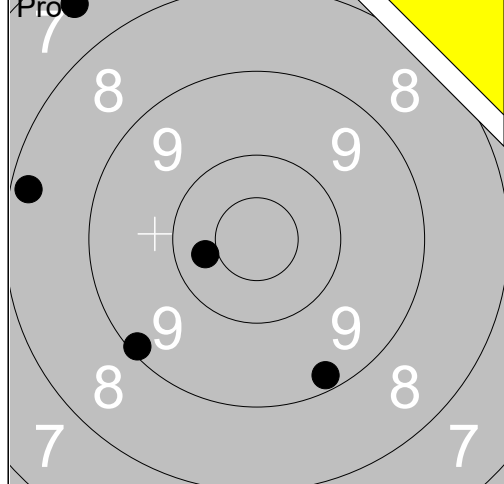

1:	7.5	↗
2:	8.2	↖
3:	10.4	↙
4:	9.1	↘
5:	9.2	↘
Serie		43.0
Total		0.0

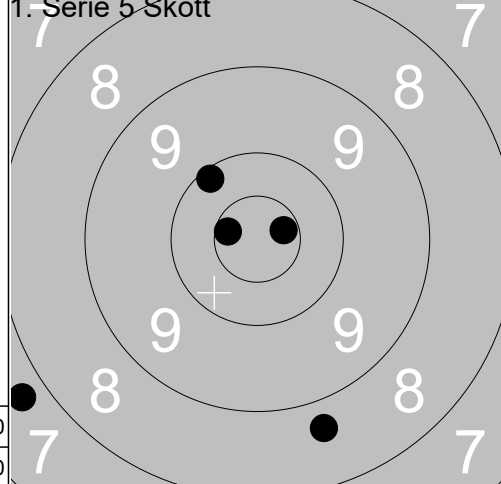

1:	10.7x	→
2:	8.7	↓
3:	10.1	↗
4:	10.6x	↖
5:	7.7	↙
Serie		45.0
Total		45.0

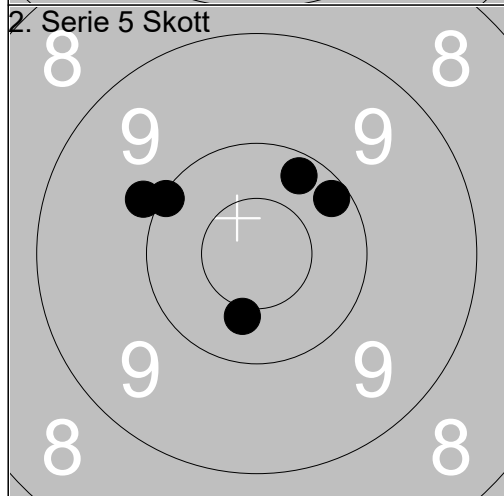

1:	10.4	↓
2:	10.2	↗
3:	10.2	↗
4:	9.9	↖
5:	10.1	↗
Serie		49.0
Total		94.0

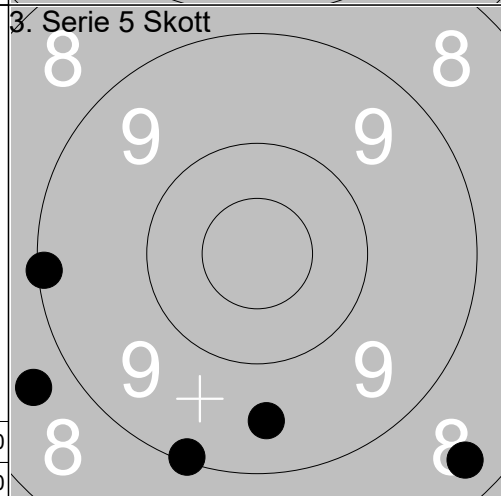

1:	8.4	↘
2:	9.5	↓
3:	9.1	↓
4:	8.7	↖
5:	9.1	↖
Serie		43.0
Total		137.0

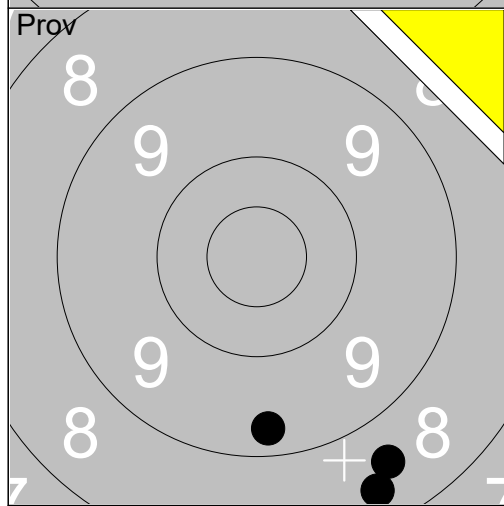

1:	8.4	↓
2:	8.6	↓
3:	9.3	↓
Serie		25.0
Total		137.0

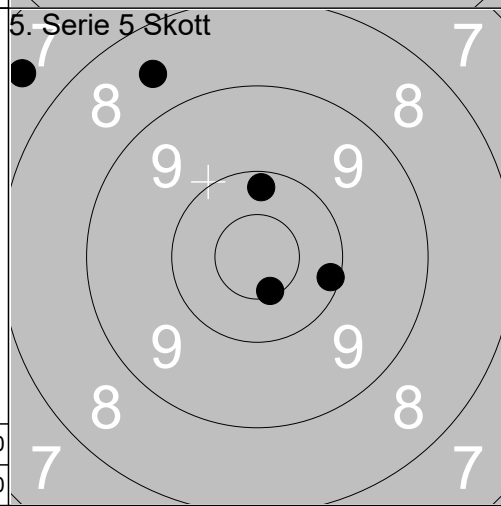

1:	10.1	→
2:	10.6x	↓
3:	8.6	↗
4:	10.2	↑
5:	7.5	↗
Serie		45.0
Total		182.0

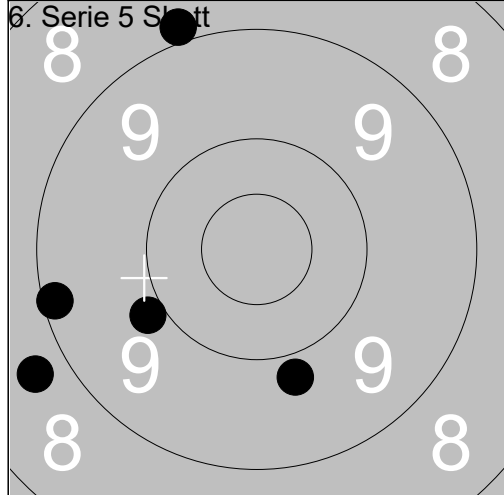

1:	8.9	↗
2:	9.8	↓
3:	9.1	↖
4:	8.7	↖
5:	9.9	↖
Serie		43.0
Total		225.0

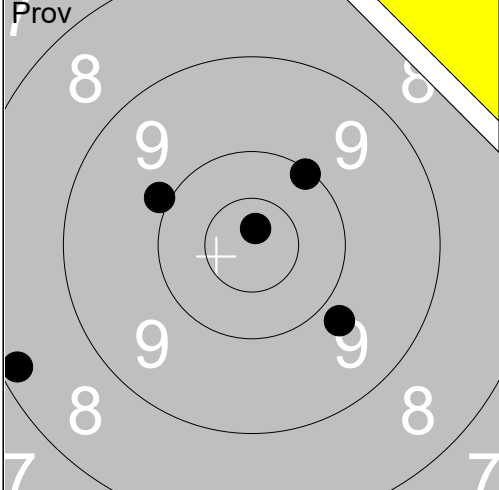
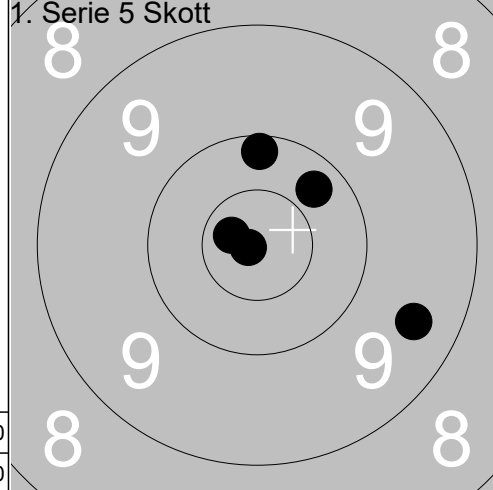
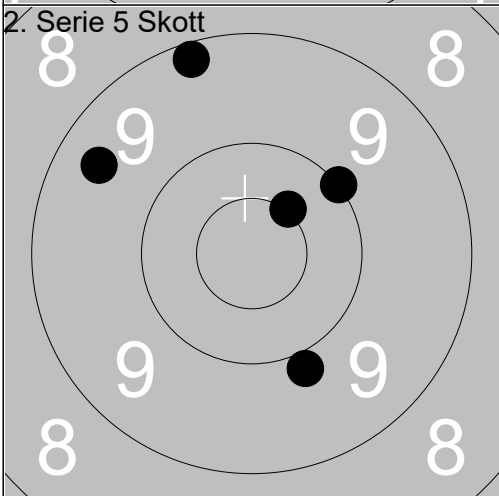
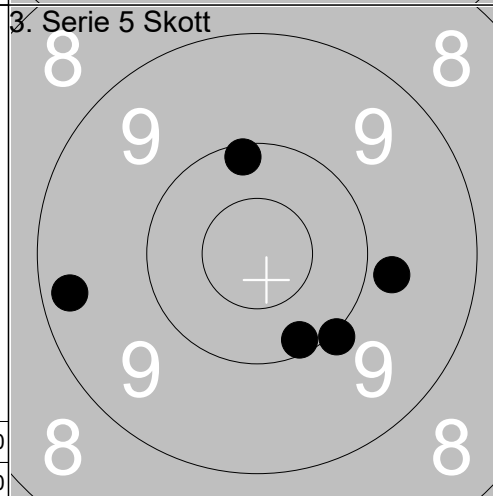
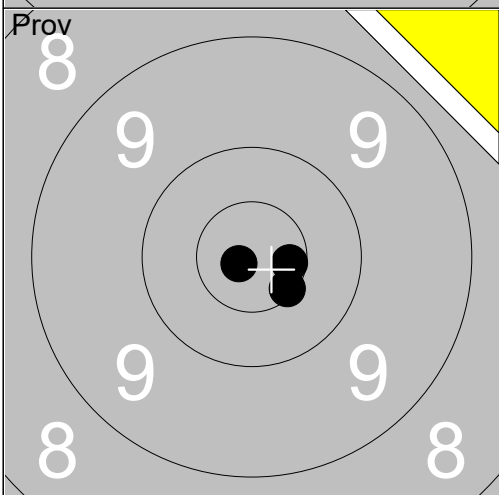
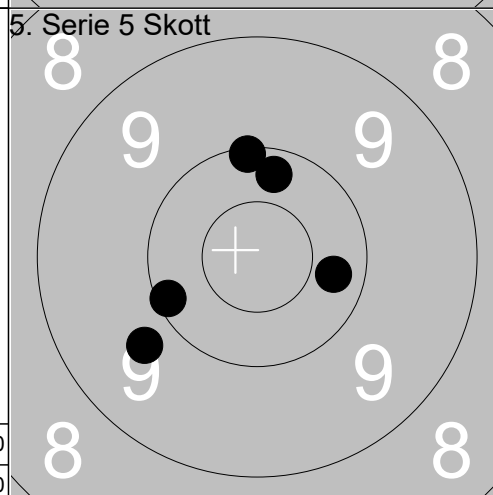
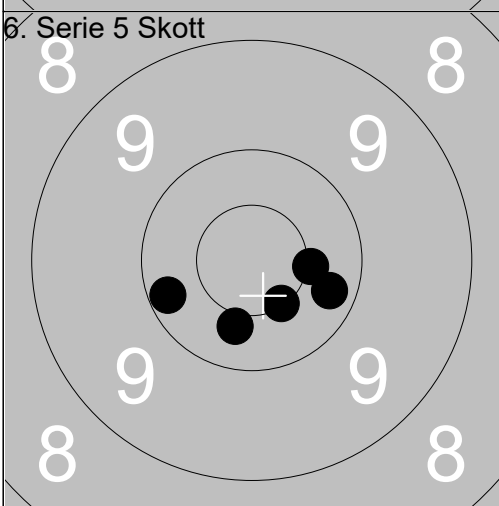
Prov  <p style="text-align: right; font-size: 2em; font-weight: bold;">7</p>	1: 8.2 ↙ 2: 10.8x ↑ 3: 10.1 ↗ 4: 9.9 ↖ 5: 9.8 ↘	1. Serie 5 Skott 	1: 10.7x ↖ 2: 10.2 ↑ 3: 10.3 ↗ 4: 9.4 → 5: 10.9x ←
Serie 46.0 Total 0.0		Serie 49.0 Total 49.0	
2. Serie 5 Skott  <p style="text-align: right; font-size: 2em; font-weight: bold;">8</p>	1: 9.4 ↖ 2: 9.2 ↑ 3: 10.0 ↗ 4: 9.9 ↘ 5: 10.5x ↗	3. Serie 5 Skott 	1: 9.3 ← 2: 10.0 ↘ 3: 9.8 → 4: 10.1 ↑ 5: 10.1 ↘
Serie 47.0 Total 96.0		Serie 48.0 Total 144.0	
Prov  <p style="text-align: right; font-size: 2em; font-weight: bold;">8</p>	1: 10.6x → 2: 10.5x ↘ 3: 10.8x ←	4. Serie 5 Skott 	1: 9.7 ↖ 2: 10.3 → 3: 10.1 ↖ 4: 10.1 ↑ 5: 10.2 ↑
Serie 30.0 Total 144.0		Serie 49.0 Total 193.0	
5. Serie 5 Skott  <p style="text-align: right; font-size: 2em; font-weight: bold;">8</p>	1: 10.4x → 2: 10.4 ↘ 3: 10.5x ↘ 4: 10.2 ↖ 5: 10.2 →		
Serie 50.0 Total 243.0			

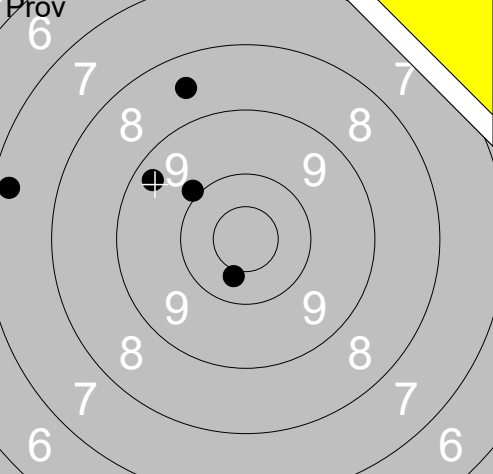
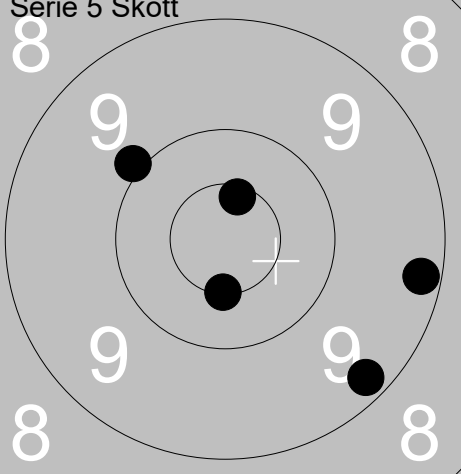
<p>Prov</p> 	<p>1: 7.3 ← 2: 8.5 ↗ 3: 10.4 ↘ 4: 9.9 ↗ 5: 9.3 ↗</p>	<p>1. Serie 5 Skott</p> 	<p>1: 10.6x ↗ 2: 9.2 → 3: 10.5x ↘ 4: 9.9 ↗ 5: 9.2 ↘</p>
Serie 43.0		Serie 47.0	
Total 0.0		Total 47.0	

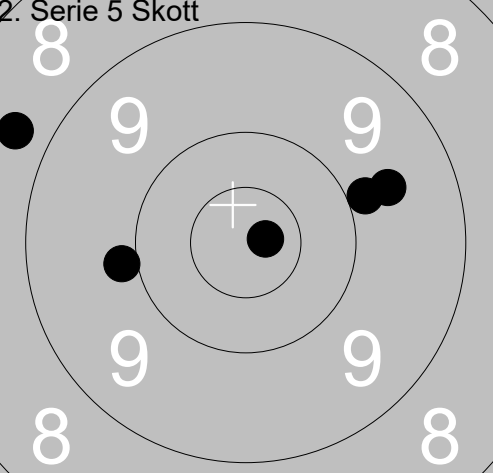
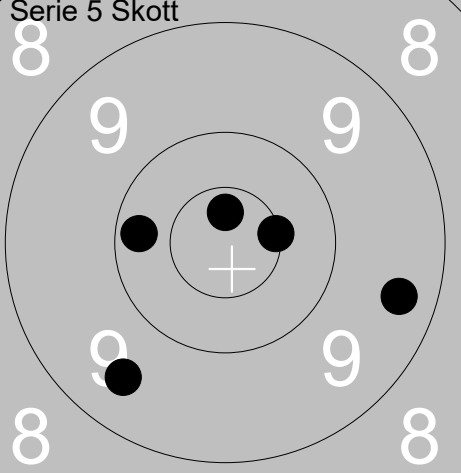
<p>2. Serie 5 Skott</p> 	<p>1: 10.8x → 2: 9.6 → 3: 9.9 ← 4: 8.7 ← 5: 9.9 →</p>	<p>3. Serie 5 Skott</p> 	<p>1: 9.5 ↘ 2: 10.2 ← 3: 9.4 → 4: 10.5x → 5: 10.7x ↑</p>
Serie 45.0		Serie 48.0	
Total 92.0		Total 140.0	

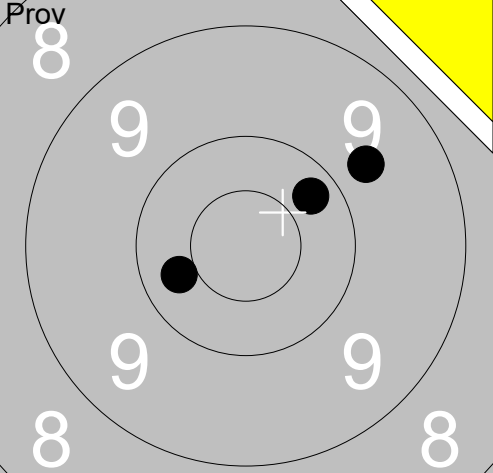
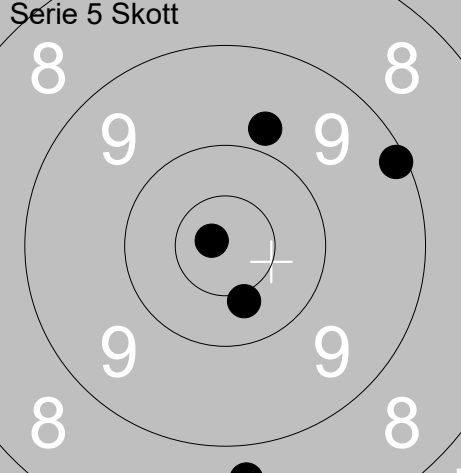
<p>Prov</p> 	<p>1: 9.7 ↗ 2: 10.3 ↗ 3: 10.3 ←</p>	<p>5. Serie 5 Skott</p> 	<p>1: 9.8 ↗ 2: 9.1 ↗ 3: 10.4 ↘ 4: 10.8x ← 5: 8.7 ↘</p>
Serie 29.0		Serie 46.0	
Total 140.0		Total 186.0	

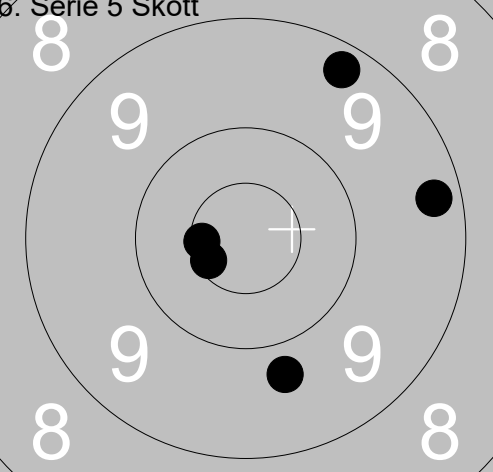
<p>6. Serie 5 Skott</p> 	<p>1: 9.7 ↘ 2: 9.3 → 3: 9.3 ↗ 4: 10.6x ← 5: 10.6x ←</p>		
Serie 47.0			
Total 233.0			

<p>Prov</p>	<p>1. Serie 5 Skott</p>	<p>1: 9.2 ←</p> <p>2: 9.4 ↗</p> <p>3: 7.9 ↗</p> <p>4: 8.8 ←</p> <p>5: 9.6 ↘</p>
Serie 42.0	Serie 47.0	
Total 0.0	Total 47.0	

<p>2. Serie 5 Skott</p>	<p>3. Serie 5 Skott</p>	<p>1: 10.2 ↖</p> <p>2: 10.4 ↗</p> <p>3: 9.6 →</p> <p>4: 10.2 ↑</p> <p>5: 10.7x ↘</p>
Serie 49.0	Serie 47.0	
Total 96.0	Total 143.0	

<p>Prov</p>	<p>5. Serie 5 Skott</p>	<p>1: 9.7 ←</p> <p>2: 10.5x ←</p> <p>3: 10.3 ↓</p>
Serie 29.0	Serie 49.0	
Total 143.0	Total 192.0	

<p>6. Serie 5 Skott</p>		<p>1: 9.5 →</p> <p>2: 10.0 →</p> <p>3: 10.6x ↗</p> <p>4: 10.2 ↘</p> <p>5: 9.8 ↓</p>
Serie 48.0		
Total 240.0		

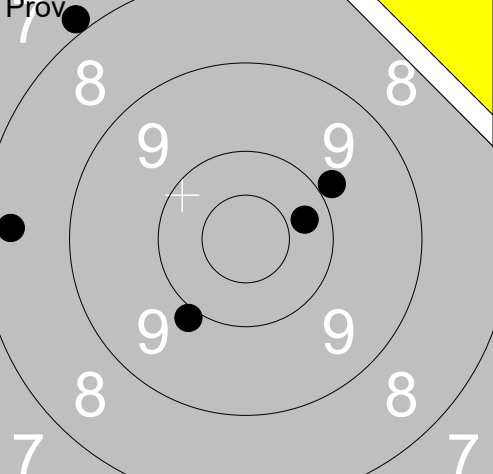
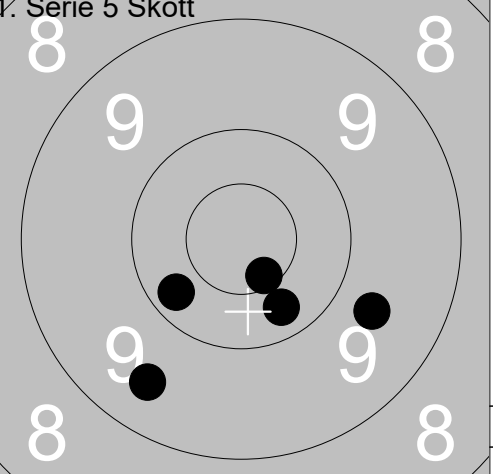

<p>Prov</p> 	<p>1: 7.9 ↗ 2: 8.4 ← 3: 9.9 ↓ 4: 9.9 ↘ 5: 10.3 →</p> <hr/> <p>Serie 43.0 Total 0.0</p>	<p>1. Serie 5 Skott</p> 	<p>1: 9.5 ↓ 2: 9.7 → 3: 10.2 ↘ 4: 10.6x ↓ 5: 10.3 ↓</p> <hr/> <p>Serie 48.0 Total 48.0</p>
--	--	--	--

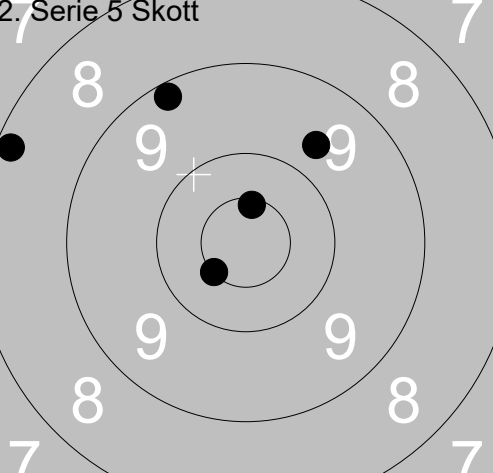
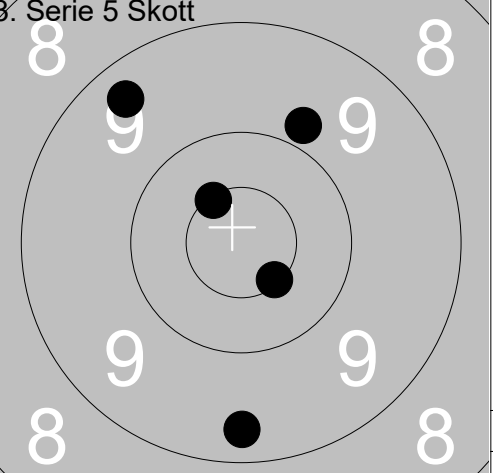
<p>2. Serie 5 Skott</p> 	<p>1: 9.7 ↗ 2: 10.5x ↘ 3: 8.2 ← 4: 10.6x ↑ 5: 9.2 ↗</p> <hr/> <p>Serie 46.0 Total 94.0</p>	<p>3. Serie 5 Skott</p> 	<p>1: 10.5x ↗ 2: 9.3 ↓ 3: 9.8 ↗ 4: 9.4 ↗ 5: 10.5x ↓</p> <hr/> <p>Serie 47.0 Total 141.0</p>
---	--	---	---

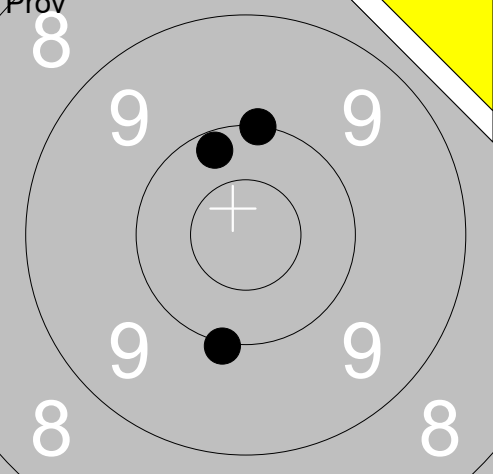
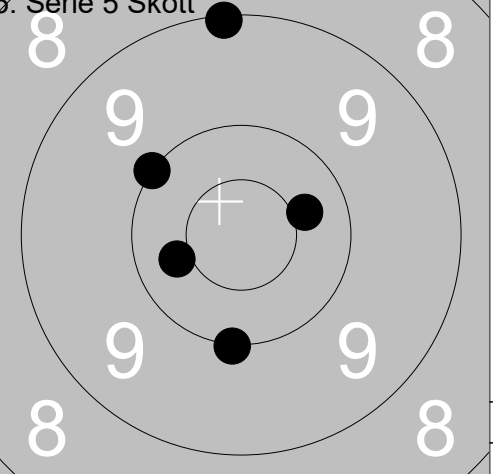
<p>Prov</p> 	<p>1: 10.0 ↑ 2: 10.2 ↑ 3: 10.0 ↓</p> <hr/> <p>Serie 30.0 Total 141.0</p>	<p>5. Serie 5 Skott</p> 	<p>1: 10.4 → 2: 10.0 ↓ 3: 10.0 ↗ 4: 10.4 ← 5: 9.1 ↑</p> <hr/> <p>Serie 49.0 Total 190.0</p>
--	--	--	---

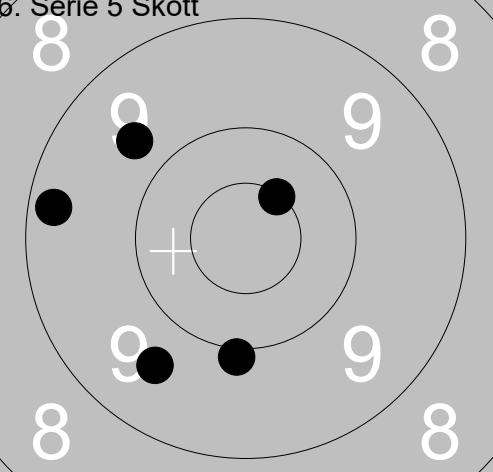
<p>6. Serie 5 Skott</p> 	<p>1: 10.5x ↗ 2: 9.3 ← 3: 10.0 ↓ 4: 9.7 ↗ 5: 9.6 ↓</p> <hr/> <p>Serie 47.0 Total 237.0</p>		
--	--	--	--

Skjutlag

Tavla

2

7

Berndt Steffen

Ramselefors

Frötuna

C

St

07.07.2024

Tavelträffen A 2024

Ramselefors SKF

Prov

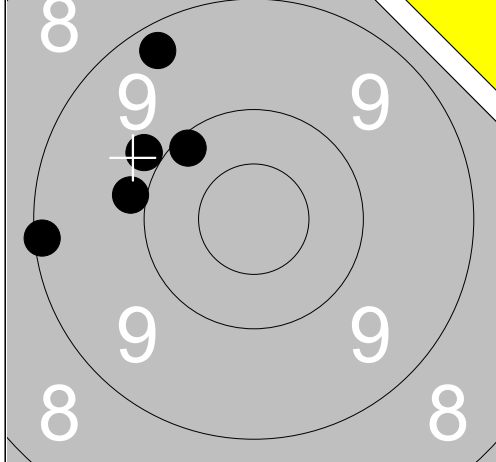

1: 10.1 ↗  
 2: 9.1 ←  
 3: 9.9 ↗  
 4: 9.3 ↗  
 5: 9.9 ←

Serie 46.0

Total 0.0

1. Serie 5 Skott

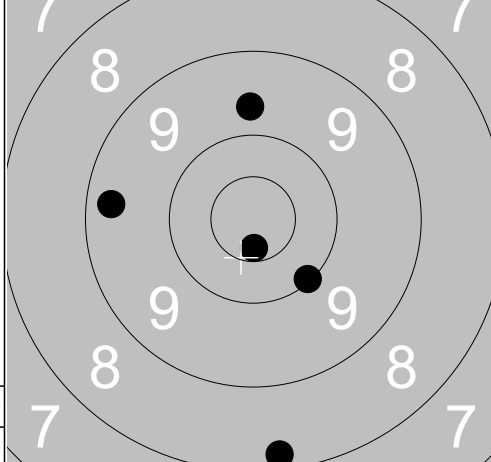

1: 9.7 ↑  
 2: 9.3 ←  
 3: 10.6x ↓  
 4: 8.2 ↓  
 5: 10.1 ↓

Serie 46.0

Total 46.0

2. Serie 5 Skott

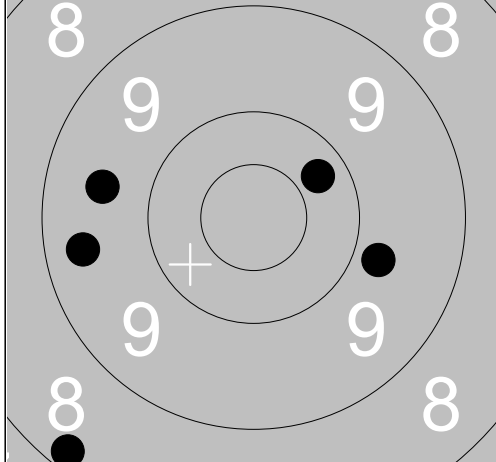

1: 10.3 ↗  
 2: 9.4 ←  
 3: 9.8 ↗  
 4: 9.6 ←  
 5: 8.2 ↓

Serie 45.0

Total 91.0

3. Serie 5 Skott

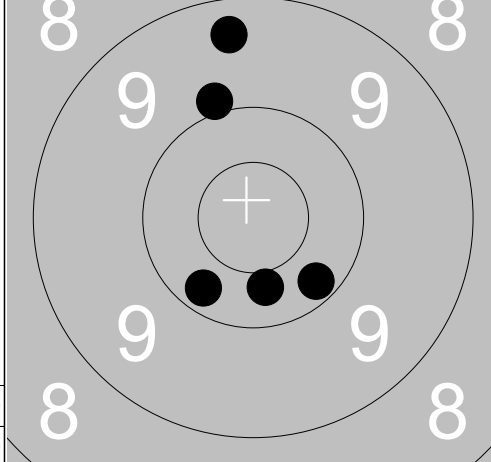

1: 10.2 ↘  
 2: 10.4 ↓  
 3: 10.2 ↘  
 4: 9.9 ↗  
 5: 9.4 ↑

Serie 48.0

Total 139.0

Prov

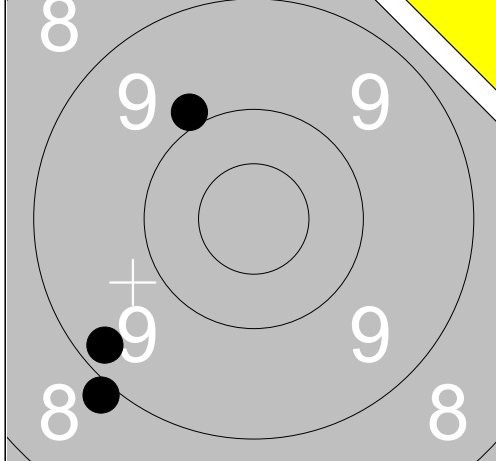

1: 9.9 ↗  
 2: 9.3 ↓  
 3: 8.9 ↓

Serie 26.0

Total 139.0

5. Serie 5 Skott

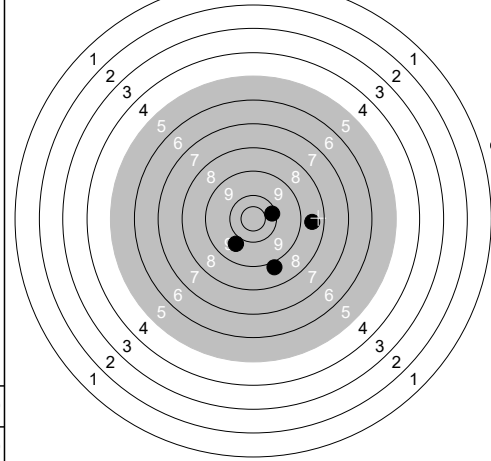

1: 0.0 →  
 2: 10.2 →  
 3: 8.5 →  
 4: 8.8 ↓  
 5: 9.8 ↓

Serie 35.0

Total 174.0

6. Serie 5 Skott

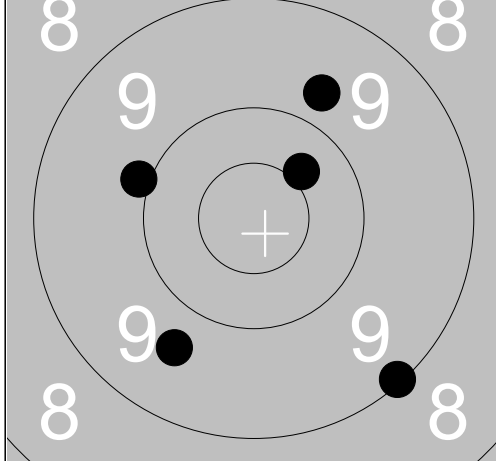

1: 10.4 ↗  
 2: 9.1 ↓  
 3: 9.7 ↗  
 4: 9.7 ↓  
 5: 9.9 ←

Serie 46.0

Total 220.0

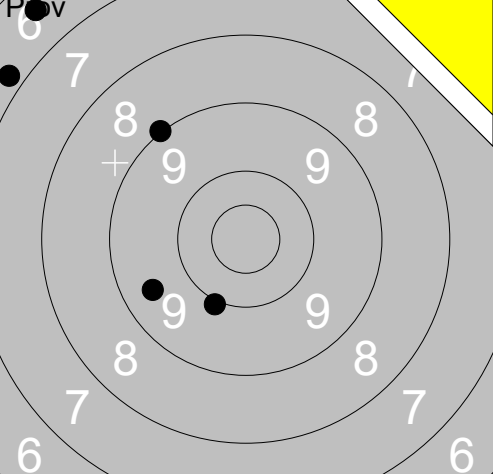
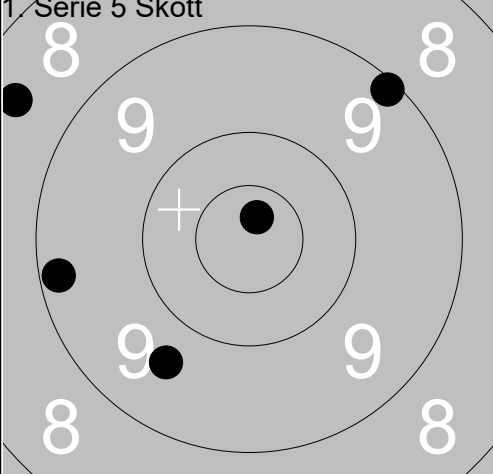
 <p>Prov</p>	<p>1: 10.0 ↘ 2: 6.5 ↗ 3: 6.8 ↗ 4: 9.5 ↖ 5: 9.0 ↗</p>	<p>1. Serie 5 Skott</p>  <p>1: 9.2 ← 2: 9.6 ↘ 3: 8.5 ↖ 4: 9.1 ↗ 5: 10.7x ↗</p>
Serie 40.0		Serie 45.0
Total 0.0		Total 45.0

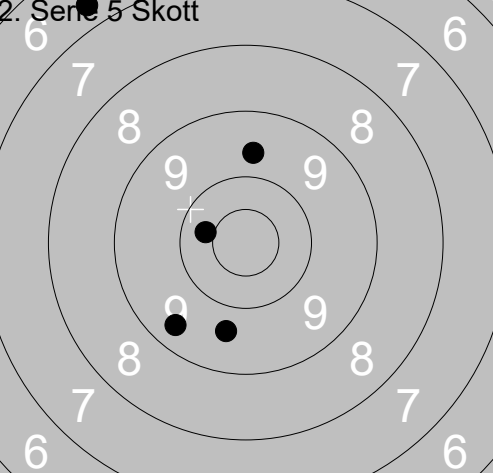
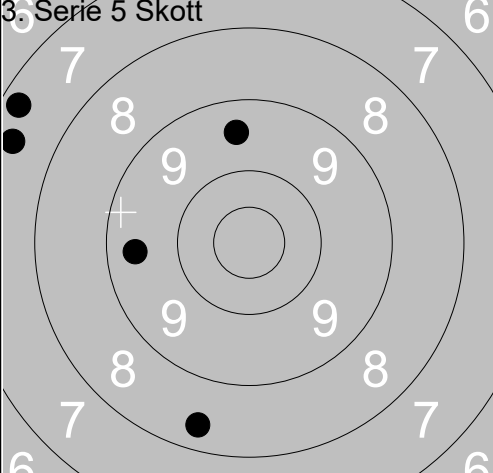
 <p>2. Serie 5 Skott</p>	<p>1: 10.4 ← 2: 6.7 ↗ 3: 9.7 ↘ 4: 9.7 ↑ 5: 9.4 ↘</p>	<p>3. Serie 5 Skott</p>  <p>1: 9.5 ↑ 2: 8.4 ↘ 3: 7.4 ↖ 4: 9.4 ← 5: 7.3 ↖</p>
Serie 43.0		Serie 40.0
Total 88.0		Total 128.0

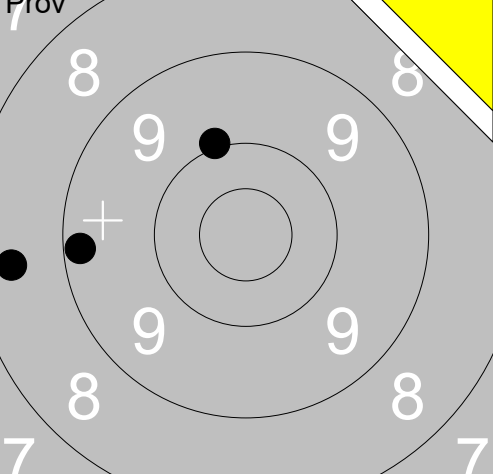
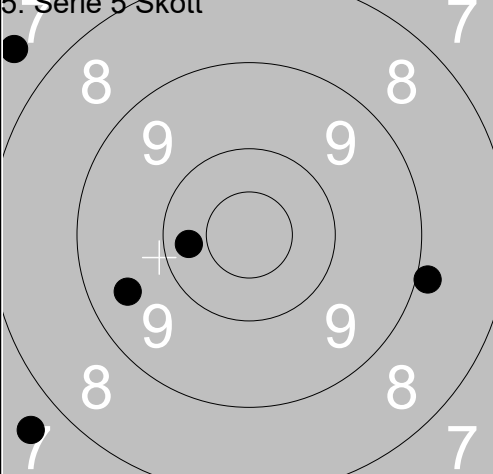
 <p>Prov</p>	<p>1: 9.2 ← 2: 10.0 ↑ 3: 8.4 ←</p>	<p>5. Serie 5 Skott</p>  <p>1: 9.5 ← 2: 10.3 ← 3: 8.9 → 4: 7.6 ↘ 5: 7.6 ↖</p>
Serie 27.0		Serie 41.0
Total 128.0		Total 169.0

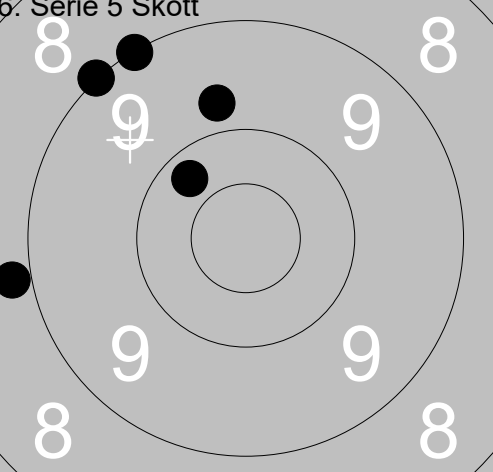
 <p>6. Serie 5 Skott</p>	<p>1: 9.8 ↑ 2: 10.3 ↗ 3: 9.0 ↗ 4: 9.0 ↗ 5: 8.9 ←</p>	
Serie 45.0		
Total 214.0		

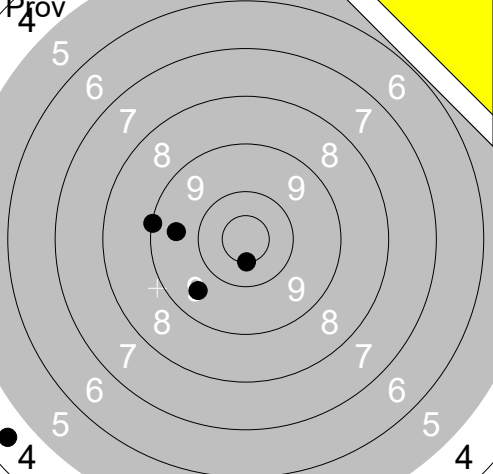
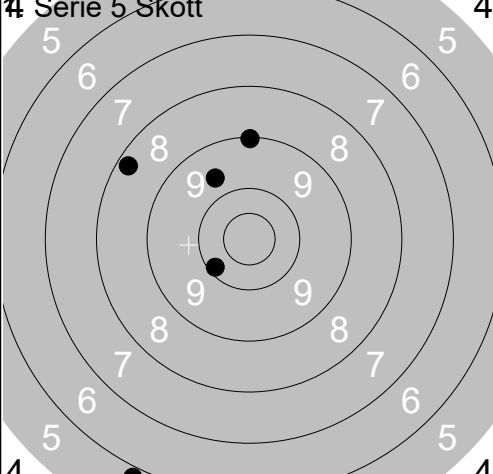
<p><b>1. Prov</b></p>  <p style="text-align: right; font-weight: bold;">4</p>	<p>1: 9.6 ←</p> <p>2: 4.5 ↙</p> <p>3: 9.1 ←</p> <p>4: 9.6 ↙</p> <p>5: 10.5x ↓</p>	<p><b>4. Serie 5 Skott</b></p>  <p style="text-align: right; font-weight: bold;">4</p>	<p>1: 10.1 ↙</p> <p>2: 9.1 ↑</p> <p>3: 8.3 ↙</p> <p>4: 9.7 ↗</p> <p>5: 5.8 ↓</p>
Serie 41.0	Total 0.0	Serie 41.0	Total 41.0

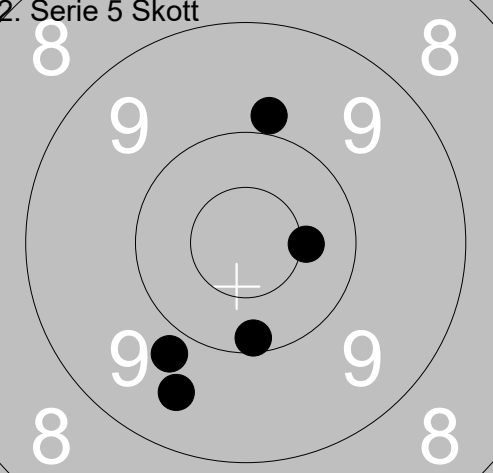
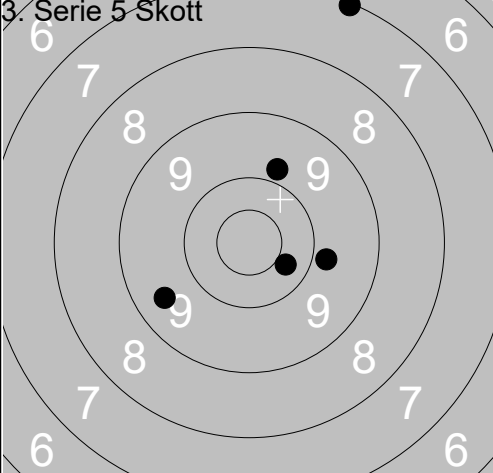
<p><b>2. Serie 5 Skott</b></p>  <p style="text-align: right; font-weight: bold;">4</p>	<p>1: 9.8 ↙</p> <p>2: 9.9 ↑</p> <p>3: 10.1 ↓</p> <p>4: 10.4x →</p> <p>5: 9.5 ↙</p>	<p><b>3. Serie 5 Skott</b></p>  <p style="text-align: right; font-weight: bold;">4</p>	<p>1: 9.8 →</p> <p>2: 7.1 ↑</p> <p>3: 9.8 ↑</p> <p>4: 10.3 ↘</p> <p>5: 9.5 ↙</p>
Serie 47.0	Total 88.0	Serie 44.0	Total 132.0

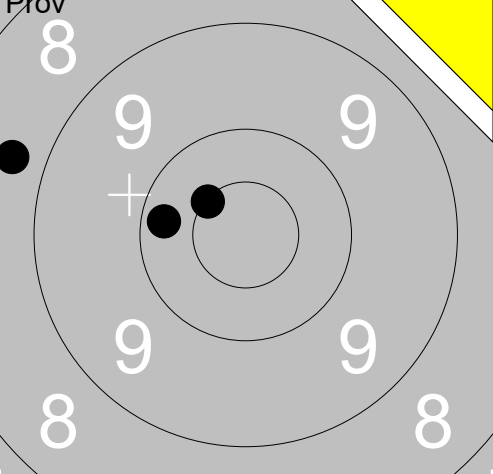
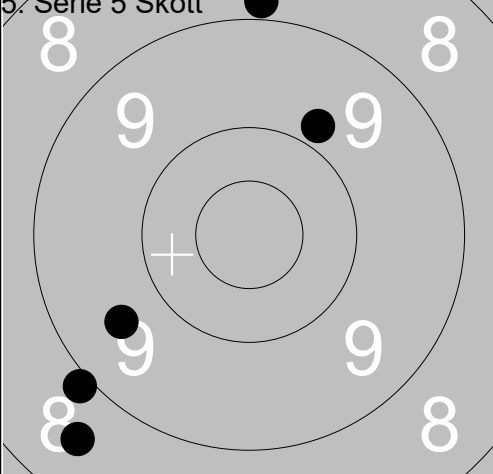
<p><b>3. Prov</b></p>  <p style="text-align: right; font-weight: bold;">4</p>	<p>1: 10.5x ↘</p> <p>2: 10.2 ←</p> <p>3: 8.7 ←</p>	<p><b>5. Serie 5 Skott</b></p>  <p style="text-align: right; font-weight: bold;">4</p>	<p>1: 8.9 ↙</p> <p>2: 9.8 ↗</p> <p>3: 9.6 ↙</p> <p>4: 8.5 ↙</p> <p>5: 8.9 ↑</p>
Serie 28.0	Total 132.0	Serie 42.0	Total 174.0

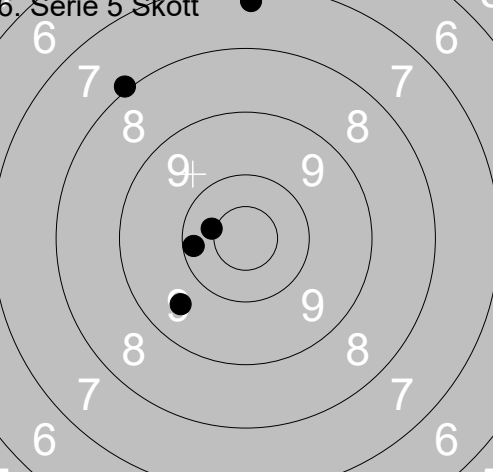
<p><b>6. Serie 5 Skott</b></p>  <p style="text-align: right; font-weight: bold;">4</p>	<p>1: 10.4x ←</p> <p>2: 10.2 ←</p> <p>3: 8.0 ↘</p> <p>4: 9.6 ↙</p> <p>5: 7.3 ↑</p>		
Serie 44.0	Total 218.0		

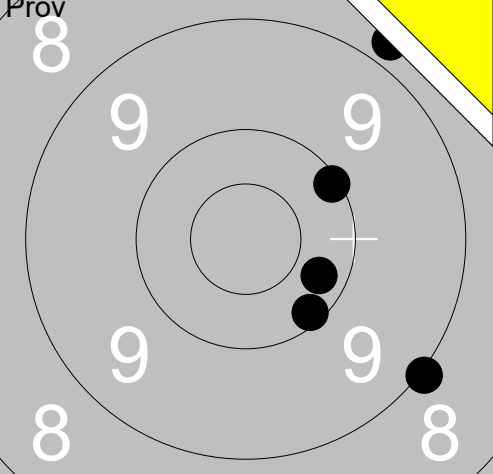
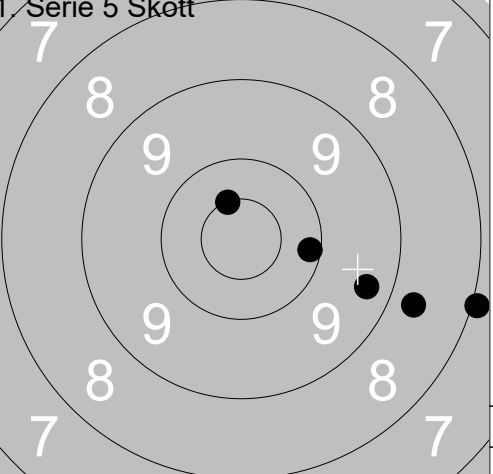
<p>Prov</p> 	<p>1: 10.3 ↘ 2: 10.1 ↘ 3: 9.0 ↘ 4: 10.1 ↗ 5: 8.8 ↗</p> <p>Serie 47.0 Total 0.0</p>	<p>1. Serie 5 Skott</p> 	<p>1: 10.1 → 2: 10.5x ↗ 3: 9.4 ↘ 4: 8.0 ↘ 5: 8.7 ↘</p> <p>Serie 45.0 Total 45.0</p>
--	--	--	---

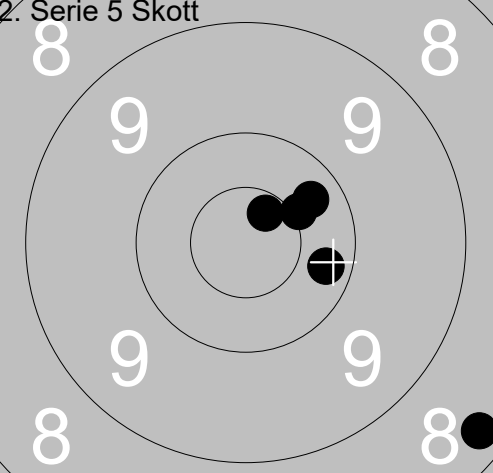
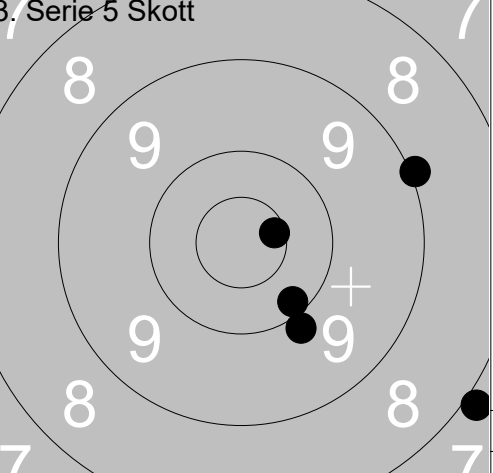
<p>2. Serie 5 Skott</p> 	<p>1: 10.2 → 2: 10.3 ↗ 3: 10.4x ↗ 4: 10.7x ↗ 5: 8.3 ↘</p> <p>Serie 48.0 Total 93.0</p>	<p>3. Serie 5 Skott</p> 	<p>1: 10.6x → 2: 10.2 ↘ 3: 9.9 ↘ 4: 9.0 ↗ 5: 7.9 ↘</p> <p>Serie 45.0 Total 138.0</p>
---	--	---	--

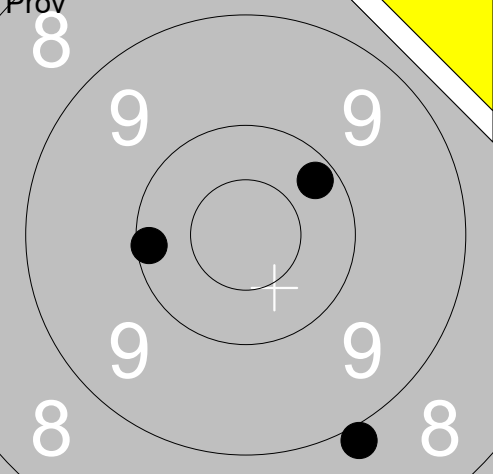
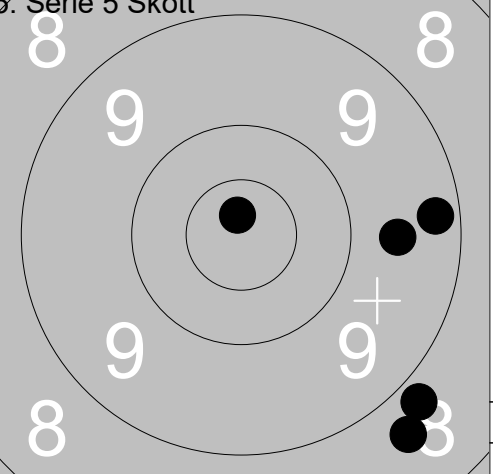
<p>Prov</p> 	<p>1: 10.1 ← 2: 10.2 ↗ 3: 8.9 ↘</p> <p>Serie 28.0 Total 138.0</p>	<p>5. Serie 5 Skott</p> 	<p>1: 9.3 → 2: 9.6 → 3: 8.7 ↘ 4: 8.8 ↘ 5: 10.8x ↗</p> <p>Serie 44.0 Total 182.0</p>
--	---	--	---

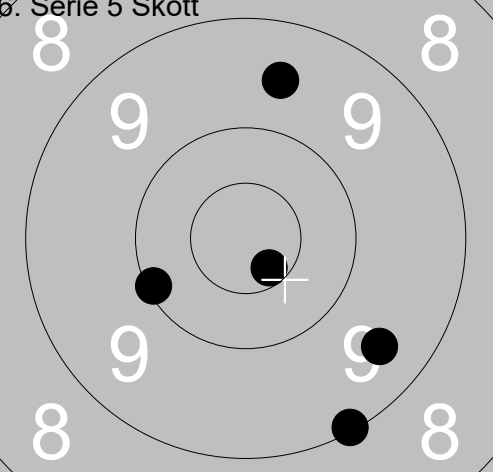
<p>6. Serie 5 Skott</p> 	<p>1: 10.1 ← 2: 10.6x ↘ 3: 9.5 ↘ 4: 9.1 ↘ 5: 9.6 ↗</p> <p>Serie 47.0 Total 229.0</p>		
--	--	--	--

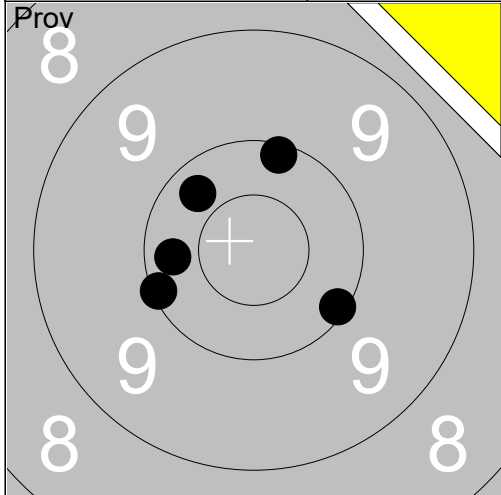

1: 10.1 ↘  
 2: 10.1 ↑  
 3: 10.3 ←  
 4: 10.3 ↗  
 5: 10.1 ←

Serie	50.0
Total	0.0

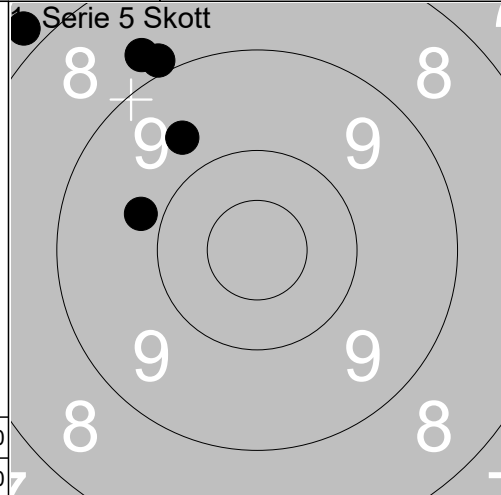

1: 9.7 ↗  
 2: 8.8 ↗  
 3: 9.8 ←  
 4: 8.9 ↗  
 5: 7.8 ↗

Serie	41.0
Total	41.0

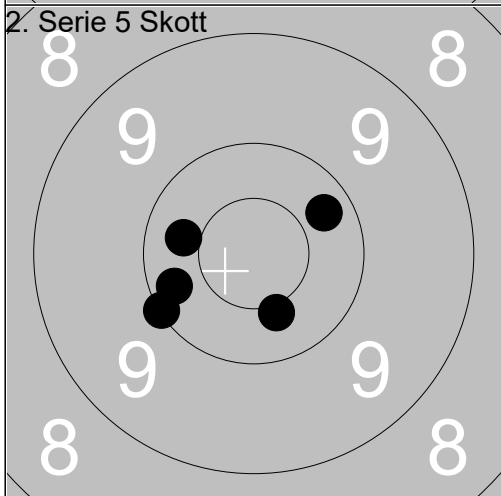

1: 10.3 ←  
 2: 10.3 ↗  
 3: 10.4x ↓  
 4: 10.2 ←  
 5: 10.0 ←

Serie	50.0
Total	91.0

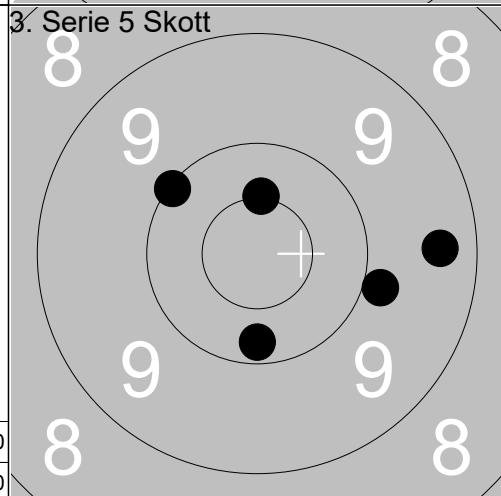

1: 10.2 ↓  
 2: 9.9 →  
 3: 9.4 →  
 4: 10.5x ↑  
 5: 10.1 ↗

Serie	48.0
Total	139.0

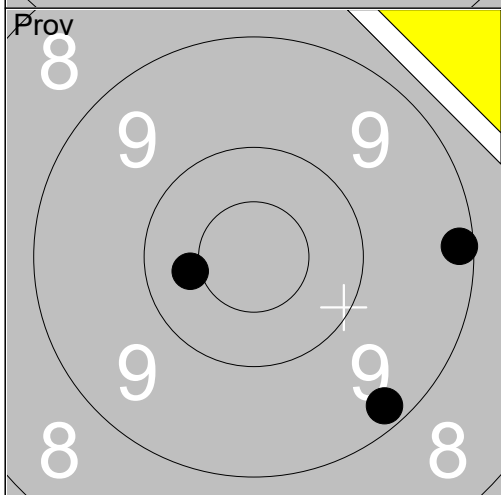

1: 9.2 ↘  
 2: 9.2 →  
 3: 10.4 ←

Serie	28.0
Total	139.0

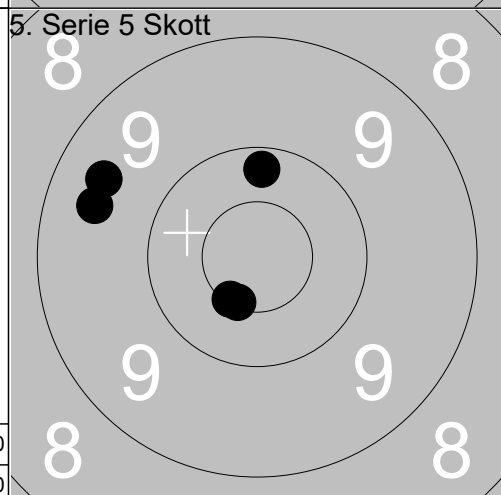

1: 10.2 ↑  
 2: 10.5x ↓  
 3: 9.5 ↗  
 4: 9.5 ←  
 5: 10.5x ↓

Serie	48.0
Total	187.0

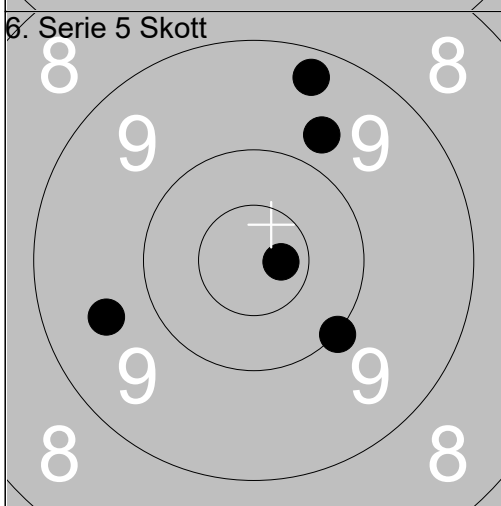

1: 9.7 ↗  
 2: 10.7x →  
 3: 9.3 ↑  
 4: 10.0 ↘  
 5: 9.6 ←

Serie	47.0
Total	234.0

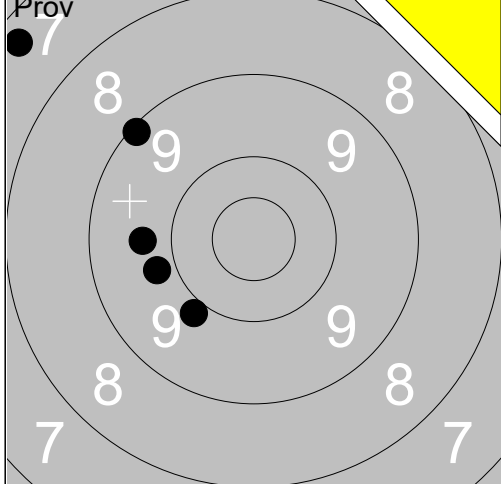

1:	9.1	↖
2:	7.3	↗
3:	9.9	↘
4:	9.7	←
5:	9.8	←
Serie		43.0
Total		0.0

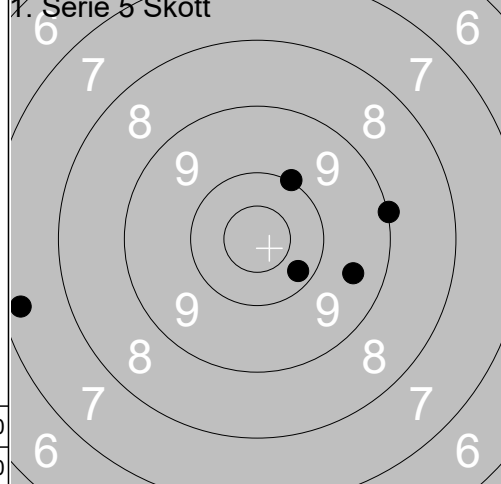

1:	7.3	←
2:	10.0	↗
3:	9.5	↘
4:	9.0	→
5:	10.2	↘
Serie		45.0
Total		45.0

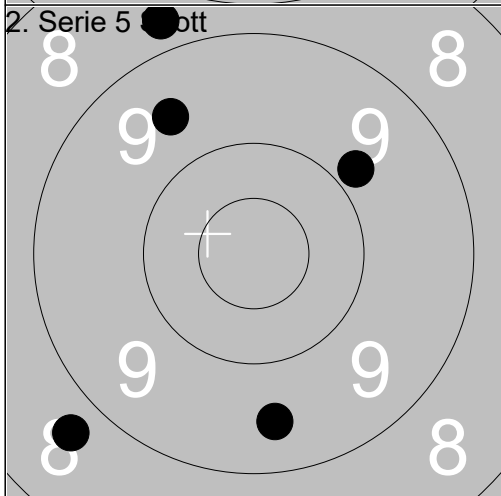

1:	9.6	↗
2:	9.8	↗
3:	8.7	↘
4:	9.5	↘
5:	8.8	↗
Serie		43.0
Total		88.0

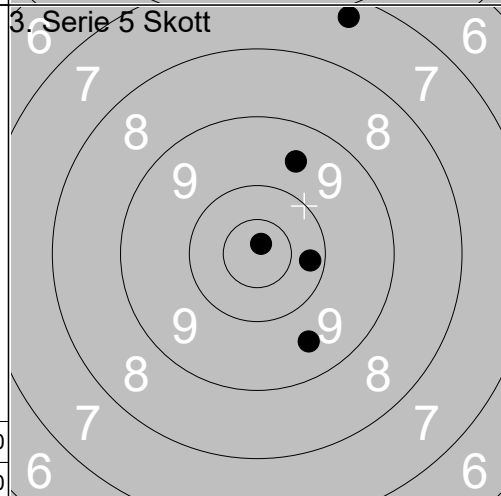

1:	9.6	↗
2:	10.2	→
3:	9.5	↘
4:	7.3	↗
5:	10.8x	↗
Serie		45.0
Total		133.0

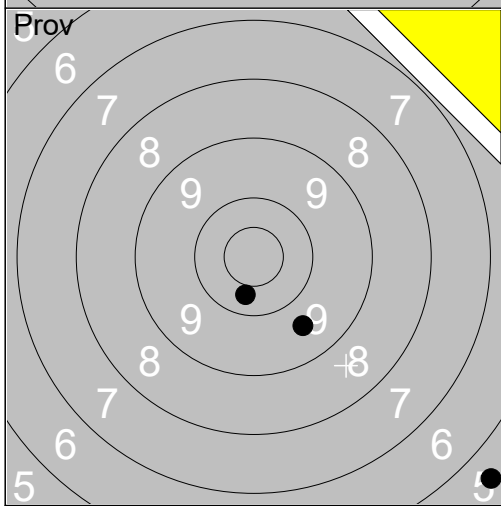

1:	9.6	↘
2:	5.6	↘
3:	10.3	↘
Serie		24.0
Total		133.0

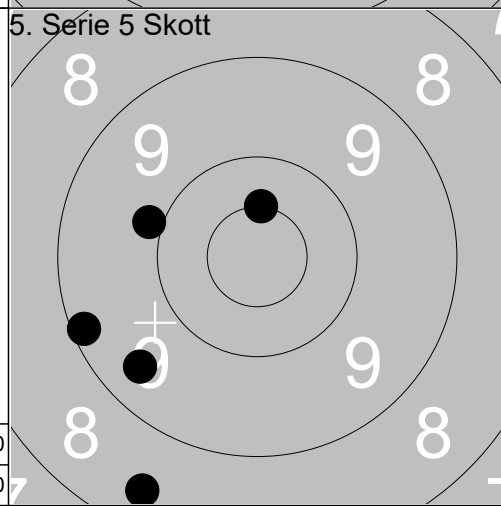

1:	9.9	←
2:	10.5x	↗
3:	9.1	←
4:	9.4	↘
5:	8.4	↘
Serie		45.0
Total		178.0

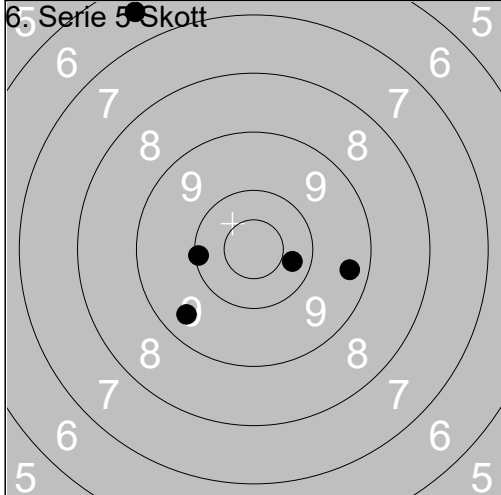

1:	9.4	→
2:	10.3	→
3:	10.1	←
4:	6.5	↗
5:	9.4	↘
Serie		44.0
Total		222.0

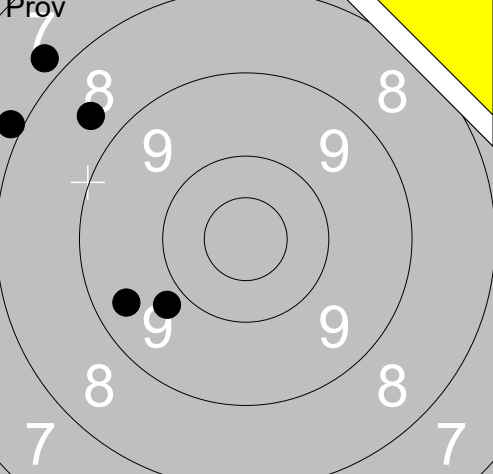
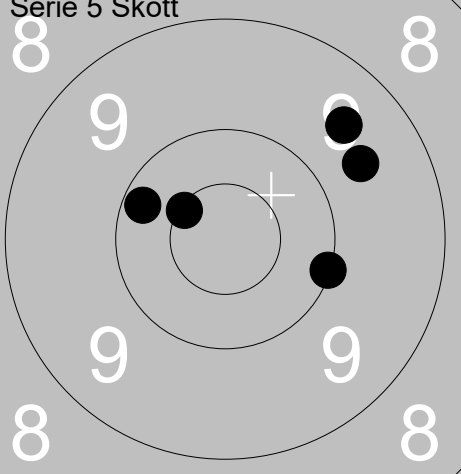
<p>Prov</p>  <table border="1" style="width:100%; border-collapse: collapse;"> <tr><td>1:</td><td>7.8</td><td>↗</td></tr> <tr><td>2:</td><td>8.6</td><td>↗</td></tr> <tr><td>3:</td><td>7.9</td><td>↗</td></tr> <tr><td>4:</td><td>9.4</td><td>↖</td></tr> <tr><td>5:</td><td>9.8</td><td>↖</td></tr> <tr><td colspan="2">Serie</td><td>40.0</td></tr> <tr><td colspan="2">Total</td><td>0.0</td></tr> </table>	1:	7.8	↗	2:	8.6	↗	3:	7.9	↗	4:	9.4	↖	5:	9.8	↖	Serie		40.0	Total		0.0	<p>1. Serie 5 Skott</p>  <table border="1" style="width:100%; border-collapse: collapse;"> <tr><td>1:</td><td>9.6</td><td>↗</td></tr> <tr><td>2:</td><td>10.2</td><td>↖</td></tr> <tr><td>3:</td><td>9.5</td><td>↗</td></tr> <tr><td>4:</td><td>10.5x</td><td>↖</td></tr> <tr><td>5:</td><td>10.0</td><td>→</td></tr> <tr><td colspan="2">Serie</td><td>48.0</td></tr> <tr><td colspan="2">Total</td><td>48.0</td></tr> </table>	1:	9.6	↗	2:	10.2	↖	3:	9.5	↗	4:	10.5x	↖	5:	10.0	→	Serie		48.0	Total		48.0	
1:	7.8	↗																																										
2:	8.6	↗																																										
3:	7.9	↗																																										
4:	9.4	↖																																										
5:	9.8	↖																																										
Serie		40.0																																										
Total		0.0																																										
1:	9.6	↗																																										
2:	10.2	↖																																										
3:	9.5	↗																																										
4:	10.5x	↖																																										
5:	10.0	→																																										
Serie		48.0																																										
Total		48.0																																										

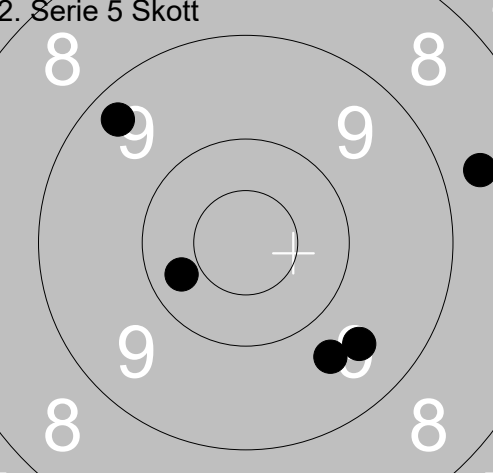
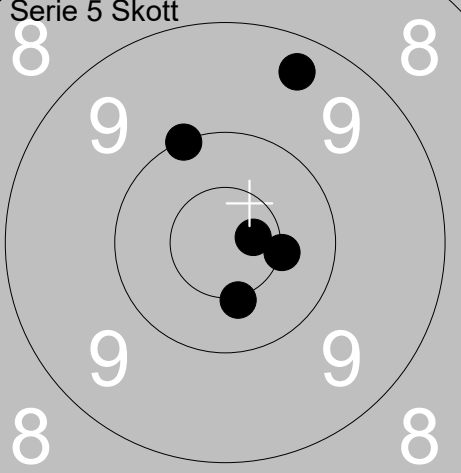
<p>2. Serie 5 Skott</p>  <table border="1" style="width:100%; border-collapse: collapse;"> <tr><td>1:</td><td>9.3</td><td>↗</td></tr> <tr><td>2:</td><td>10.3</td><td>↖</td></tr> <tr><td>3:</td><td>9.7</td><td>↘</td></tr> <tr><td>4:</td><td>8.7</td><td>→</td></tr> <tr><td>5:</td><td>9.6</td><td>↘</td></tr> <tr><td colspan="2">Serie</td><td>45.0</td></tr> <tr><td colspan="2">Total</td><td>93.0</td></tr> </table>	1:	9.3	↗	2:	10.3	↖	3:	9.7	↘	4:	8.7	→	5:	9.6	↘	Serie		45.0	Total		93.0	<p>3. Serie 5 Skott</p>  <table border="1" style="width:100%; border-collapse: collapse;"> <tr><td>1:</td><td>9.3</td><td>↗</td></tr> <tr><td>2:</td><td>10.0</td><td>↗</td></tr> <tr><td>3:</td><td>10.5x</td><td>↘</td></tr> <tr><td>4:</td><td>10.7x</td><td>→</td></tr> <tr><td>5:</td><td>10.5x</td><td>→</td></tr> <tr><td colspan="2">Serie</td><td>49.0</td></tr> <tr><td colspan="2">Total</td><td>142.0</td></tr> </table>	1:	9.3	↗	2:	10.0	↗	3:	10.5x	↘	4:	10.7x	→	5:	10.5x	→	Serie		49.0	Total		142.0	
1:	9.3	↗																																										
2:	10.3	↖																																										
3:	9.7	↘																																										
4:	8.7	→																																										
5:	9.6	↘																																										
Serie		45.0																																										
Total		93.0																																										
1:	9.3	↗																																										
2:	10.0	↗																																										
3:	10.5x	↘																																										
4:	10.7x	→																																										
5:	10.5x	→																																										
Serie		49.0																																										
Total		142.0																																										

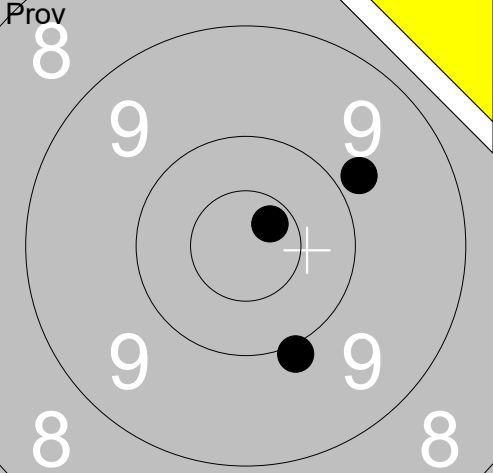
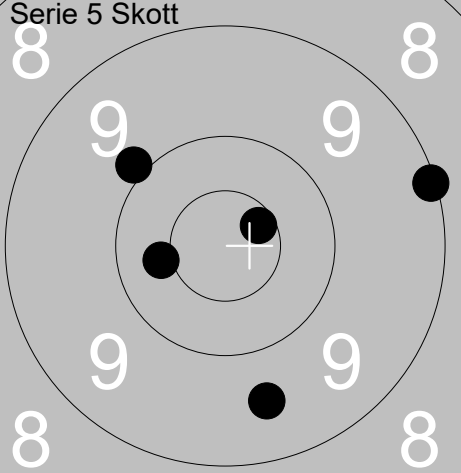
<p>Prov</p>  <table border="1" style="width:100%; border-collapse: collapse;"> <tr><td>1:</td><td>9.8</td><td>↗</td></tr> <tr><td>2:</td><td>10.7x</td><td>↗</td></tr> <tr><td>3:</td><td>9.9</td><td>↘</td></tr> <tr><td colspan="2">Serie</td><td>28.0</td></tr> <tr><td colspan="2">Total</td><td>142.0</td></tr> </table>	1:	9.8	↗	2:	10.7x	↗	3:	9.9	↘	Serie		28.0	Total		142.0	<p>5. Serie 5 Skott</p>  <table border="1" style="width:100%; border-collapse: collapse;"> <tr><td>1:</td><td>9.1</td><td>→</td></tr> <tr><td>2:</td><td>10.6x</td><td>↗</td></tr> <tr><td>3:</td><td>10.4</td><td>↖</td></tr> <tr><td>4:</td><td>9.9</td><td>↗</td></tr> <tr><td>5:</td><td>9.6</td><td>↘</td></tr> <tr><td colspan="2">Serie</td><td>47.0</td></tr> <tr><td colspan="2">Total</td><td>189.0</td></tr> </table>	1:	9.1	→	2:	10.6x	↗	3:	10.4	↖	4:	9.9	↗	5:	9.6	↘	Serie		47.0	Total		189.0	
1:	9.8	↗																																				
2:	10.7x	↗																																				
3:	9.9	↘																																				
Serie		28.0																																				
Total		142.0																																				
1:	9.1	→																																				
2:	10.6x	↗																																				
3:	10.4	↖																																				
4:	9.9	↗																																				
5:	9.6	↘																																				
Serie		47.0																																				
Total		189.0																																				

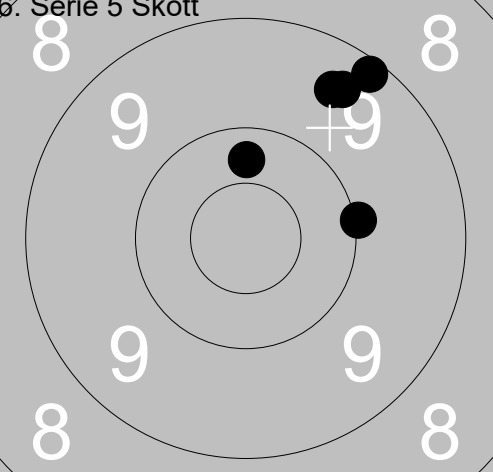
<p>6. Serie 5 Skott</p>  <table border="1" style="width:100%; border-collapse: collapse;"> <tr><td>1:</td><td>9.5</td><td>↗</td></tr> <tr><td>2:</td><td>9.2</td><td>↗</td></tr> <tr><td>3:</td><td>9.4</td><td>↗</td></tr> <tr><td>4:</td><td>10.3</td><td>↑</td></tr> <tr><td>5:</td><td>10.0</td><td>→</td></tr> <tr><td colspan="2">Serie</td><td>47.0</td></tr> <tr><td colspan="2">Total</td><td>236.0</td></tr> </table>	1:	9.5	↗	2:	9.2	↗	3:	9.4	↗	4:	10.3	↑	5:	10.0	→	Serie		47.0	Total		236.0		
1:	9.5	↗																					
2:	9.2	↗																					
3:	9.4	↗																					
4:	10.3	↑																					
5:	10.0	→																					
Serie		47.0																					
Total		236.0																					



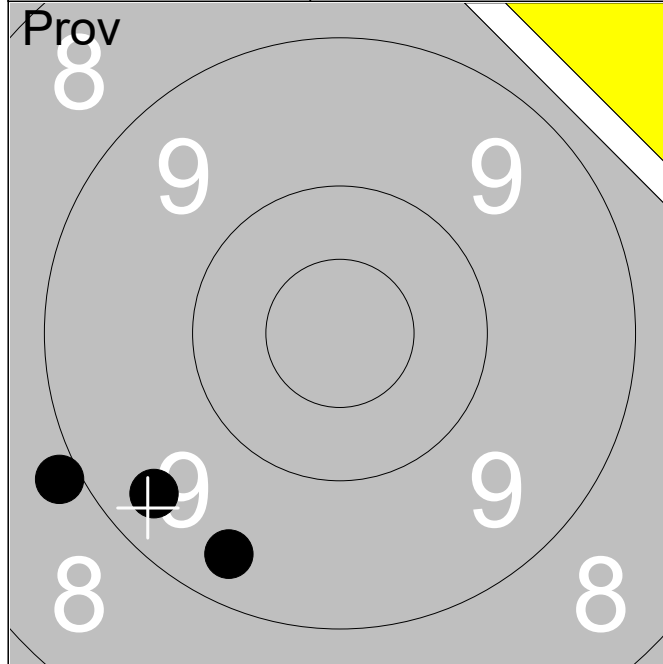

	1:	8.9	↙
	2:	9.4	↙
	3:	9.4	↙
<b>Serie</b>			<b>26.0</b>
<b>Total</b>			<b>0.0</b>

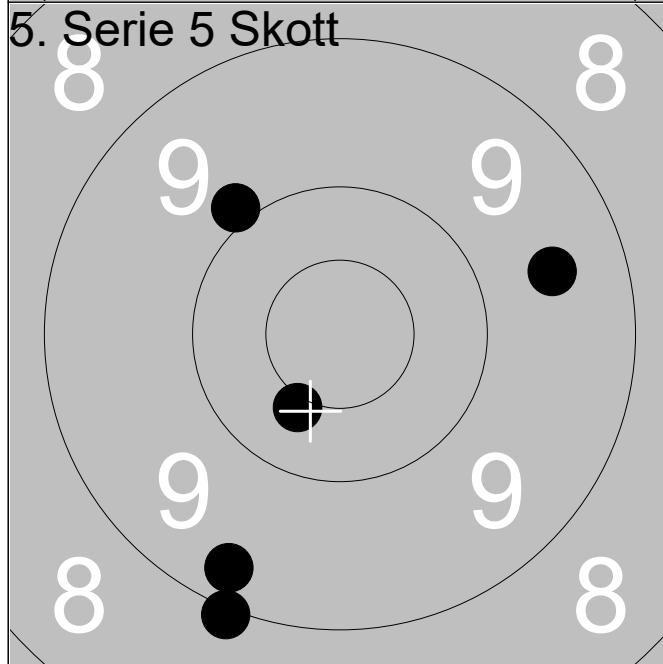

	1:	9.5	→
	2:	9.9	↖
	3:	9.3	↙
	4:	10.4x	↙
	5:	9.0	↙
<b>Serie</b>			<b>46.0</b>
<b>Total</b>			<b>46.0</b>

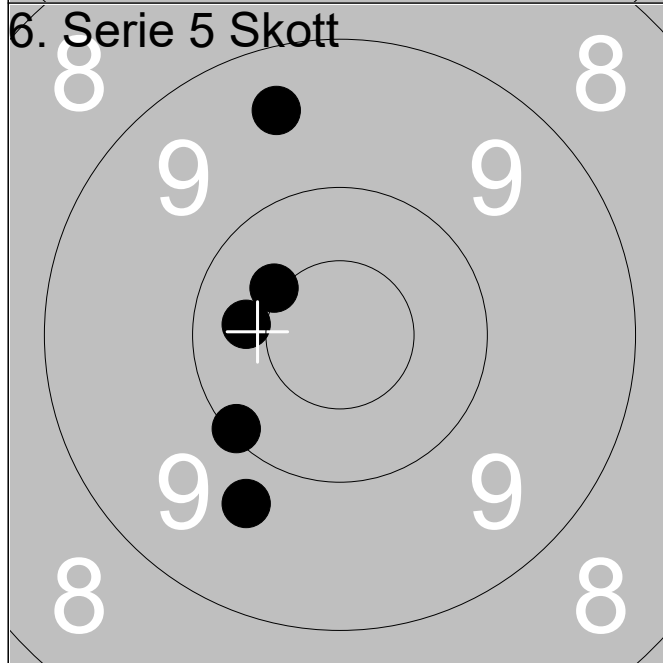

	1:	10.1	↙
	2:	9.5	↖
	3:	9.7	↙
	4:	10.4x	↖
	5:	10.4	↙
<b>Serie</b>			<b>48.0</b>
<b>Total</b>			<b>94.0</b>

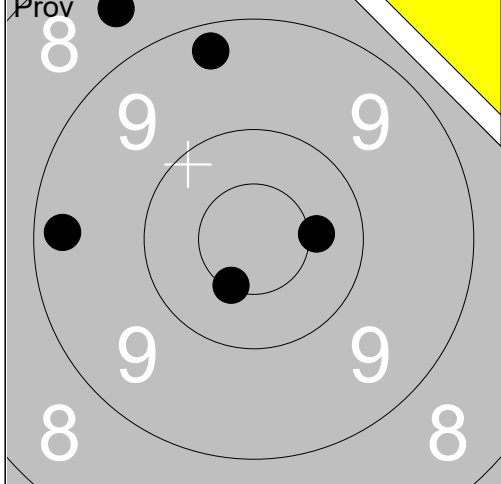

1:	9.3	↗
2:	10.4x	→
3:	10.5x	↘
4:	8.6	↗
5:	9.3	←
Serie		46.0
Total		0.0

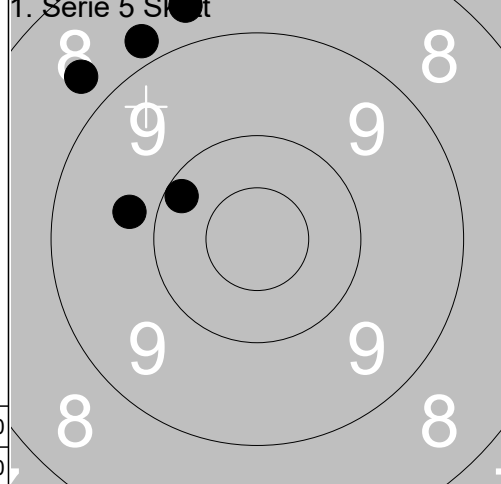

1:	8.7	↗
2:	9.8	←
3:	10.2	↗
4:	8.7	↗
5:	8.8	↗
Serie		43.0
Total		43.0

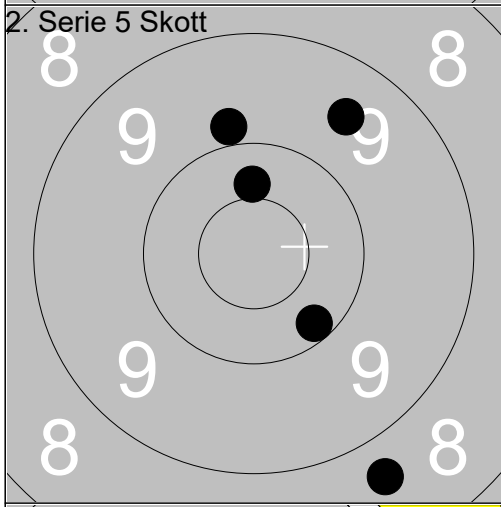

1:	9.5	↗
2:	10.4	↑
3:	9.9	↑
4:	10.2	↘
5:	8.7	↘
Serie		46.0
Total		89.0

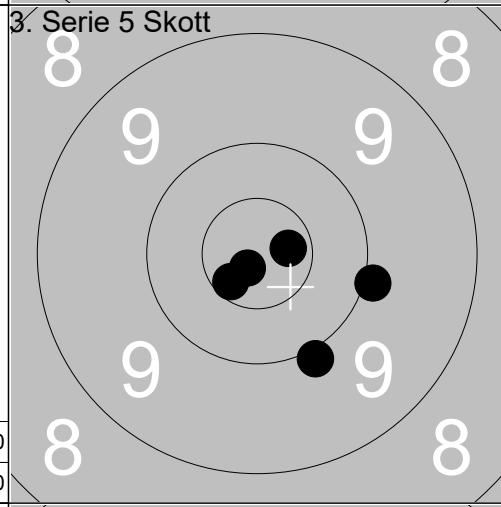

1:	10.6x	↘
2:	9.9	→
3:	10.7x	→
4:	10.8x	↘
5:	9.9	↘
Serie		48.0
Total		137.0

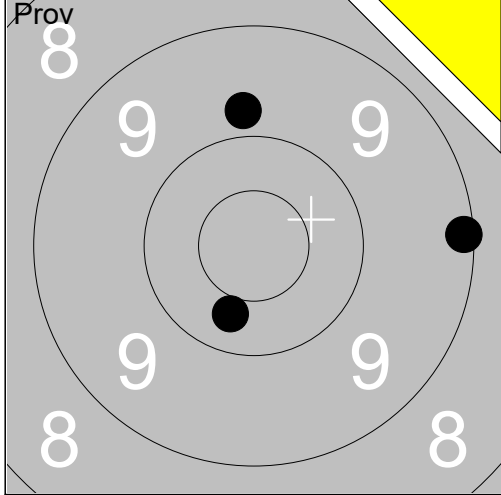

1:	9.1	→
2:	9.8	↑
3:	10.3	↘
Serie		28.0
Total		137.0

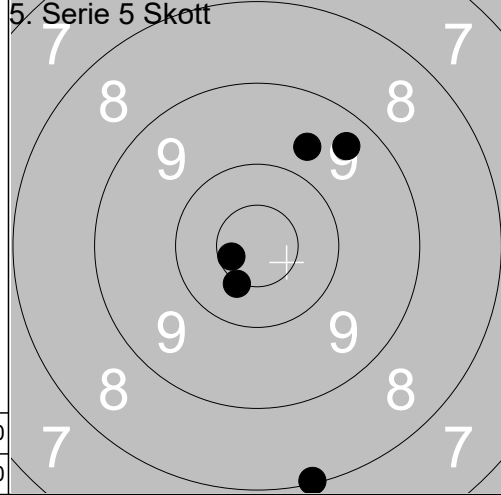

1:	9.4	↗
2:	9.7	↗
3:	8.1	↘
4:	10.6x	←
5:	10.5x	↘
Serie		46.0
Total		183.0

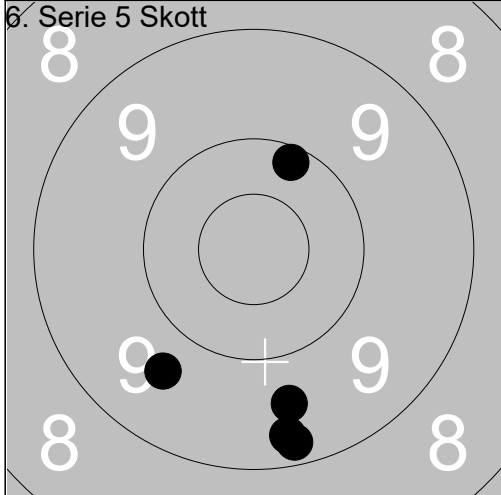

1:	9.7	↘
2:	9.2	↘
3:	10.2	↗
4:	9.6	↘
5:	9.3	↘
Serie		46.0
Total		229.0

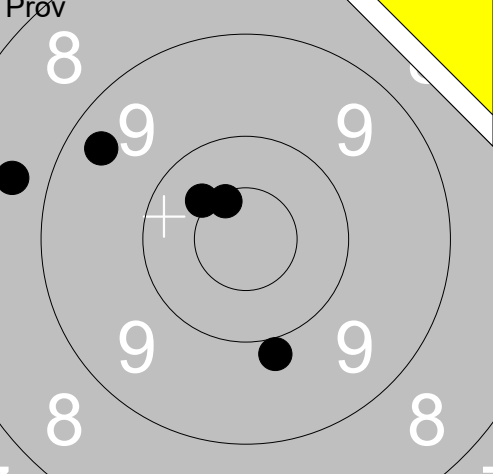
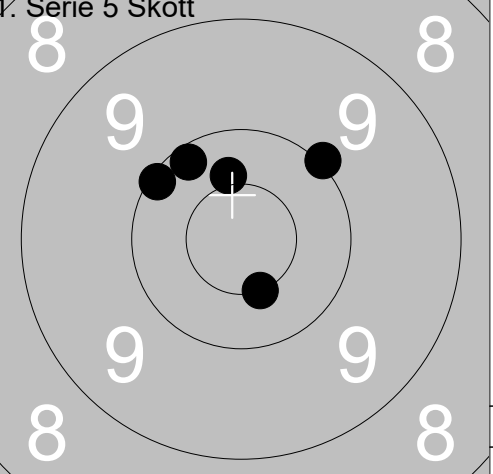
<p>Pröv</p>  <table border="1" style="width:100%; border-collapse: collapse;"> <tr><td>1:</td><td>10.4x</td><td>↗</td></tr> <tr><td>2:</td><td>8.7</td><td>←</td></tr> <tr><td>3:</td><td>9.4</td><td>↗</td></tr> <tr><td>4:</td><td>10.6x</td><td>↗</td></tr> <tr><td>5:</td><td>9.9</td><td>↘</td></tr> </table>	1:	10.4x	↗	2:	8.7	←	3:	9.4	↗	4:	10.6x	↗	5:	9.9	↘	<p>1. Serie 5 Skott</p>  <table border="1" style="width:100%; border-collapse: collapse;"> <tr><td>1:</td><td>10.1</td><td>↖</td></tr> <tr><td>2:</td><td>10.4</td><td>↑</td></tr> <tr><td>3:</td><td>10.0</td><td>↗</td></tr> <tr><td>4:</td><td>10.2</td><td>↗</td></tr> <tr><td>5:</td><td>10.5x</td><td>↘</td></tr> </table>	1:	10.1	↖	2:	10.4	↑	3:	10.0	↗	4:	10.2	↗	5:	10.5x	↘	
1:	10.4x	↗																														
2:	8.7	←																														
3:	9.4	↗																														
4:	10.6x	↗																														
5:	9.9	↘																														
1:	10.1	↖																														
2:	10.4	↑																														
3:	10.0	↗																														
4:	10.2	↗																														
5:	10.5x	↘																														
Serie 46.0	Serie 50.0																															
Total 0.0	Total 50.0																															

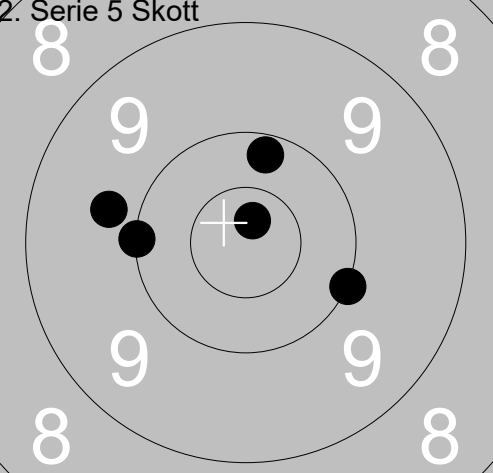
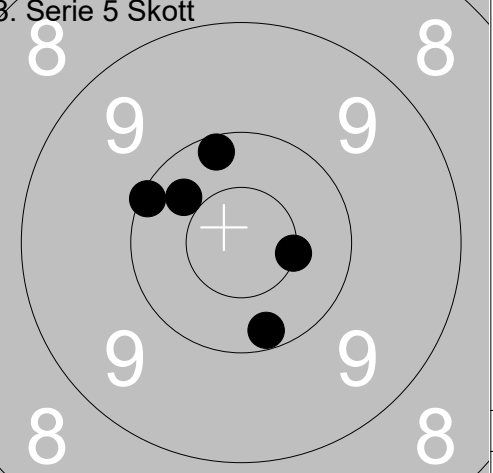
<p>2. Serie 5 Skott</p>  <table border="1" style="width:100%; border-collapse: collapse;"> <tr><td>1:</td><td>10.2</td><td>↑</td></tr> <tr><td>2:</td><td>9.8</td><td>←</td></tr> <tr><td>3:</td><td>10.8x</td><td>↑</td></tr> <tr><td>4:</td><td>10.0</td><td>→</td></tr> <tr><td>5:</td><td>10.0</td><td>←</td></tr> </table>	1:	10.2	↑	2:	9.8	←	3:	10.8x	↑	4:	10.0	→	5:	10.0	←	<p>3. Serie 5 Skott</p>  <table border="1" style="width:100%; border-collapse: collapse;"> <tr><td>1:</td><td>10.3</td><td>↖</td></tr> <tr><td>2:</td><td>10.2</td><td>↑</td></tr> <tr><td>3:</td><td>10.5x</td><td>→</td></tr> <tr><td>4:</td><td>10.1</td><td>↖</td></tr> <tr><td>5:</td><td>10.2</td><td>↘</td></tr> </table>	1:	10.3	↖	2:	10.2	↑	3:	10.5x	→	4:	10.1	↖	5:	10.2	↘	
1:	10.2	↑																														
2:	9.8	←																														
3:	10.8x	↑																														
4:	10.0	→																														
5:	10.0	←																														
1:	10.3	↖																														
2:	10.2	↑																														
3:	10.5x	→																														
4:	10.1	↖																														
5:	10.2	↘																														
Serie 49.0	Serie 50.0																															
Total 99.0	Total 149.0																															

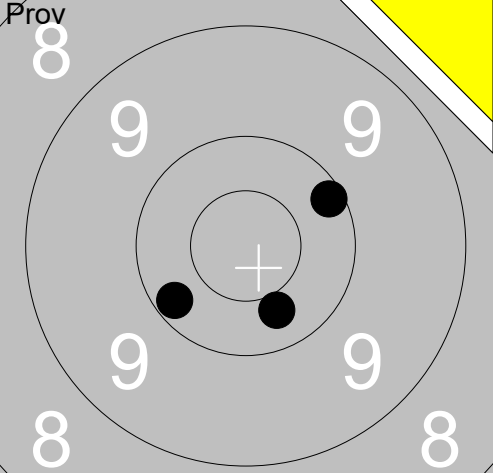
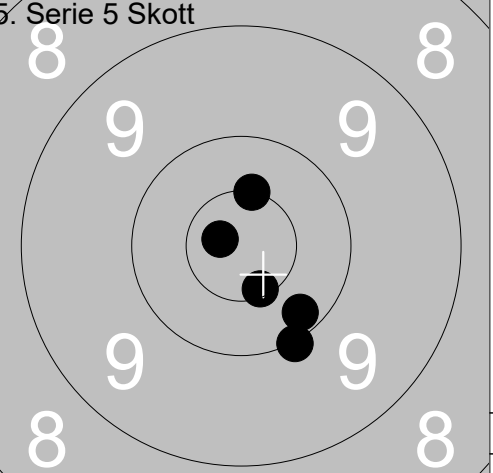
<p>Pröv</p>  <table border="1" style="width:100%; border-collapse: collapse;"> <tr><td>1:</td><td>10.1</td><td>↗</td></tr> <tr><td>2:</td><td>10.3</td><td>↘</td></tr> <tr><td>3:</td><td>10.2</td><td>←</td></tr> </table>	1:	10.1	↗	2:	10.3	↘	3:	10.2	←	<p>5. Serie 5 Skott</p>  <table border="1" style="width:100%; border-collapse: collapse;"> <tr><td>1:</td><td>10.6x</td><td>↘</td></tr> <tr><td>2:</td><td>10.0</td><td>↘</td></tr> <tr><td>3:</td><td>10.8x</td><td>↖</td></tr> <tr><td>4:</td><td>10.5x</td><td>↑</td></tr> <tr><td>5:</td><td>10.2</td><td>↘</td></tr> </table>	1:	10.6x	↘	2:	10.0	↘	3:	10.8x	↖	4:	10.5x	↑	5:	10.2	↘	
1:	10.1	↗																								
2:	10.3	↘																								
3:	10.2	←																								
1:	10.6x	↘																								
2:	10.0	↘																								
3:	10.8x	↖																								
4:	10.5x	↑																								
5:	10.2	↘																								
Serie 30.0	Serie 50.0																									
Total 149.0	Total 199.0																									

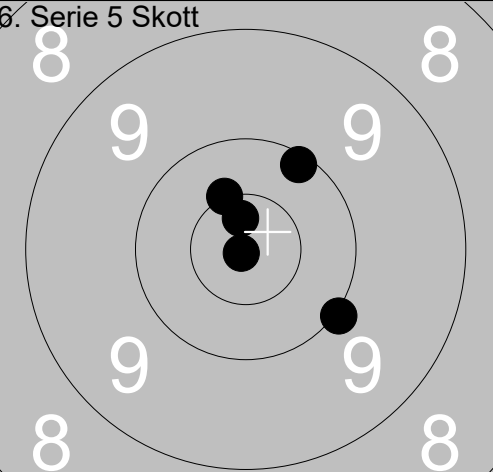
<p>6. Serie 5 Skott</p>  <table border="1" style="width:100%; border-collapse: collapse;"> <tr><td>1:</td><td>10.0</td><td>↘</td></tr> <tr><td>2:</td><td>10.7x</td><td>↑</td></tr> <tr><td>3:</td><td>10.5x</td><td>↗</td></tr> <tr><td>4:</td><td>10.9x</td><td>↖</td></tr> <tr><td>5:</td><td>10.1</td><td>↗</td></tr> </table>	1:	10.0	↘	2:	10.7x	↑	3:	10.5x	↗	4:	10.9x	↖	5:	10.1	↗		
1:	10.0	↘															
2:	10.7x	↑															
3:	10.5x	↗															
4:	10.9x	↖															
5:	10.1	↗															
Serie 50.0																	
Total 249.0																	

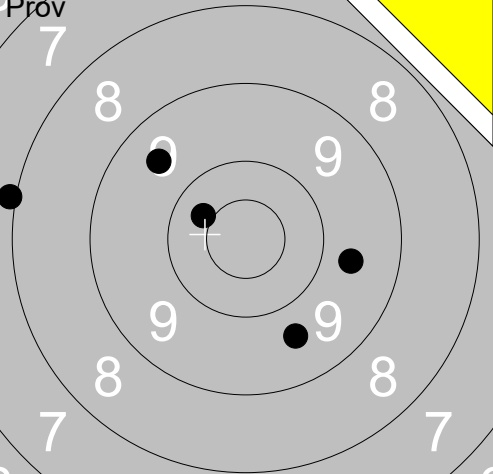
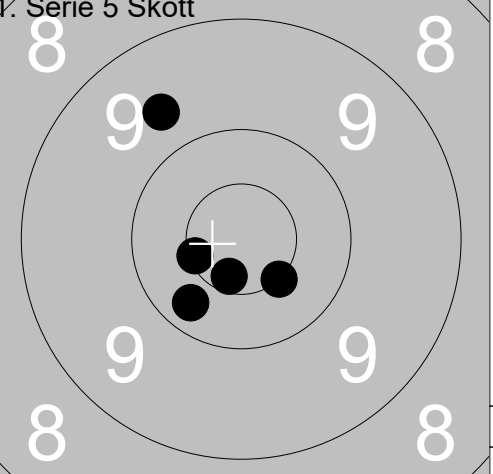
<p>Prov</p> 	<p>1: 8.0 ←</p> <p>2: 9.5 ↗</p> <p>3: 10.4 ↗</p> <p>4: 9.7 →</p> <p>5: 9.6 ↘</p>	<p>1. Serie 5 Skott</p> 	<p>1: 9.7 ↖</p> <p>2: 10.5x ←</p> <p>3: 10.5x ↘</p> <p>4: 10.3 ↘</p> <p>5: 10.6x ↘</p>
Serie 45.0		Serie 49.0	
Total 0.0		Total 49.0	

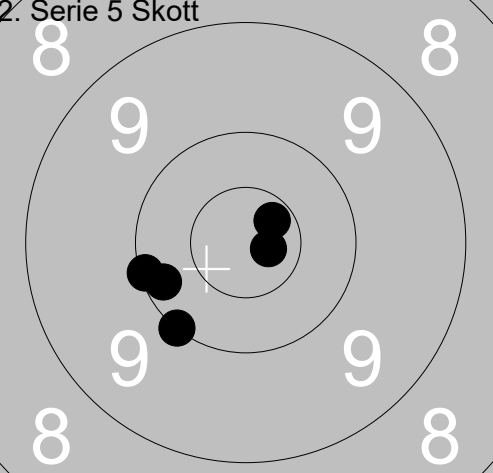
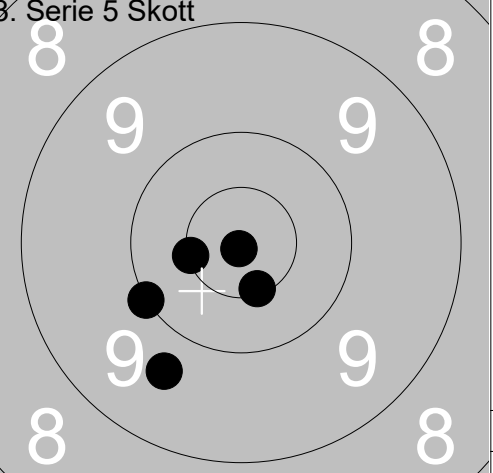
<p>2. Serie 5 Skott</p> 	<p>1: 10.8x →</p> <p>2: 10.7x ↗</p> <p>3: 10.2 ←</p> <p>4: 10.0 ↘</p> <p>5: 10.1 ←</p>	<p>3. Serie 5 Skott</p> 	<p>1: 10.5x ←</p> <p>2: 10.9x ↘</p> <p>3: 10.0 ←</p> <p>4: 10.5x ↘</p> <p>5: 9.7 ↘</p>
Serie 50.0		Serie 49.0	
Total 99.0		Total 148.0	

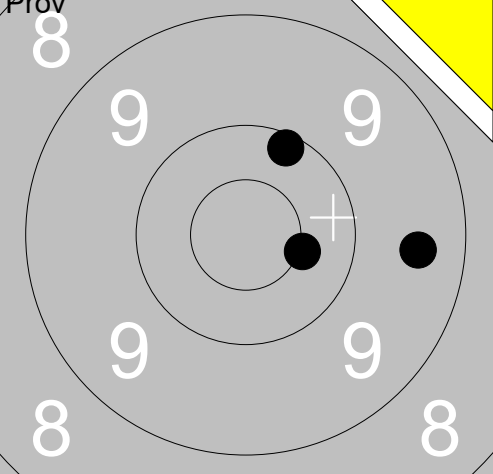
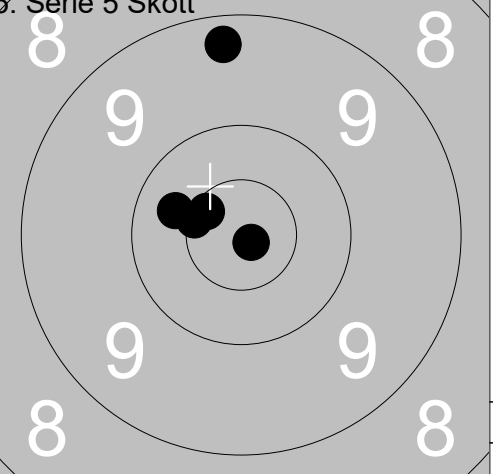
<p>Prov</p> 	<p>1: 9.5 →</p> <p>2: 10.5x →</p> <p>3: 10.1 ↗</p>	<p>5. Serie 5 Skott</p> 	<p>1: 9.3 ↑</p> <p>2: 10.6x ↖</p> <p>3: 10.4 ←</p> <p>4: 10.5x ←</p> <p>5: 10.8x ↘</p>
Serie 29.0		Serie 49.0	
Total 148.0		Total 197.0	

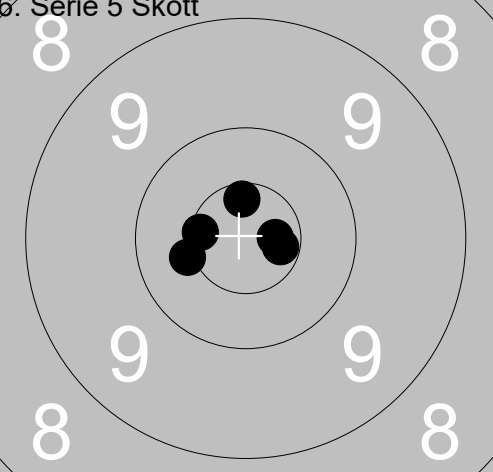
<p>6. Serie 5 Skott</p> 	<p>1: 10.7x →</p> <p>2: 10.6x ←</p> <p>3: 10.6x ↑</p> <p>4: 10.4x ←</p> <p>5: 10.7x →</p>		
Serie 50.0			
Total 247.0			

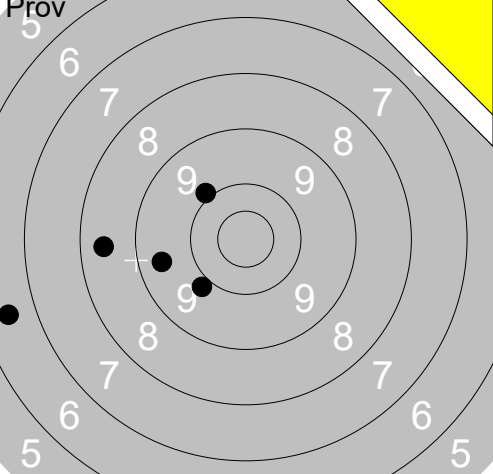
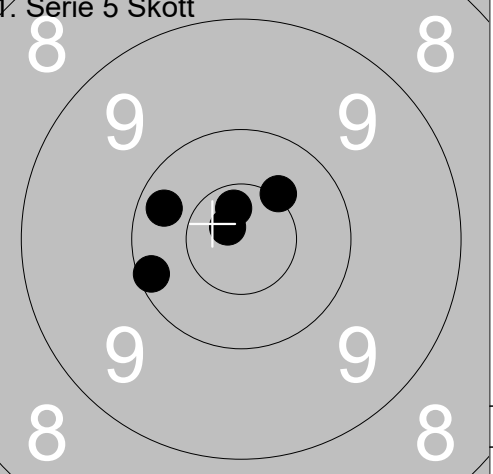
<p>Prov</p>  <table border="1" style="width:100%; border-collapse: collapse;"> <tr><td>1:</td><td>6.5</td><td>←</td></tr> <tr><td>2:</td><td>8.4</td><td>←</td></tr> <tr><td>3:</td><td>9.9</td><td>↙</td></tr> <tr><td>4:</td><td>9.5</td><td>←</td></tr> <tr><td>5:</td><td>9.9</td><td>↖</td></tr> <tr><td colspan="2">Serie</td><td>41.0</td></tr> <tr><td colspan="2">Total</td><td>0.0</td></tr> </table>	1:	6.5	←	2:	8.4	←	3:	9.9	↙	4:	9.5	←	5:	9.9	↖	Serie		41.0	Total		0.0	<p>1. Serie 5 Skott</p>  <table border="1" style="width:100%; border-collapse: collapse;"> <tr><td>1:</td><td>10.3</td><td>↖</td></tr> <tr><td>2:</td><td>10.1</td><td>←</td></tr> <tr><td>3:</td><td>10.7x</td><td>↑</td></tr> <tr><td>4:</td><td>10.5x</td><td>↗</td></tr> <tr><td>5:</td><td>10.8x</td><td>↖</td></tr> <tr><td colspan="2">Serie</td><td>50.0</td></tr> <tr><td colspan="2">Total</td><td>50.0</td></tr> </table>	1:	10.3	↖	2:	10.1	←	3:	10.7x	↑	4:	10.5x	↗	5:	10.8x	↖	Serie		50.0	Total		50.0	
1:	6.5	←																																										
2:	8.4	←																																										
3:	9.9	↙																																										
4:	9.5	←																																										
5:	9.9	↖																																										
Serie		41.0																																										
Total		0.0																																										
1:	10.3	↖																																										
2:	10.1	←																																										
3:	10.7x	↑																																										
4:	10.5x	↗																																										
5:	10.8x	↖																																										
Serie		50.0																																										
Total		50.0																																										

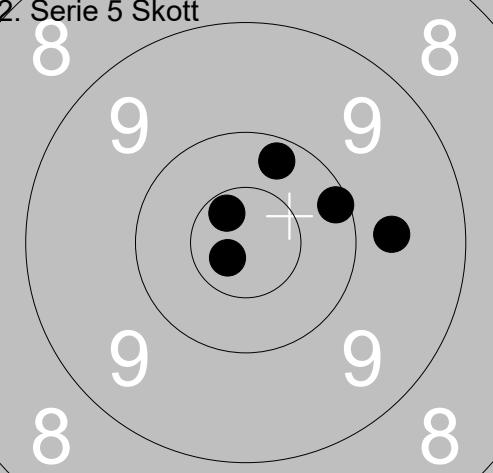
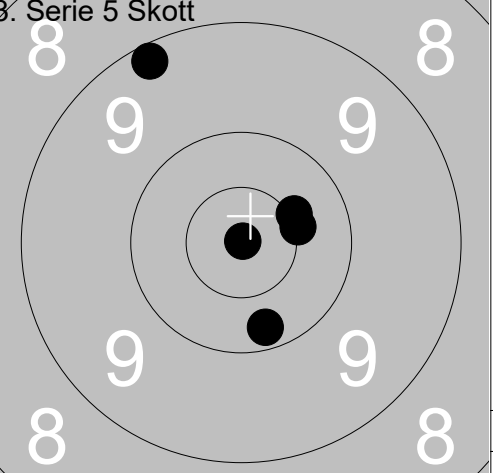
<p>2. Serie 5 Skott</p>  <table border="1" style="width:100%; border-collapse: collapse;"> <tr><td>1:</td><td>10.8x</td><td>↙</td></tr> <tr><td>2:</td><td>10.1</td><td>→</td></tr> <tr><td>3:</td><td>9.7</td><td>→</td></tr> <tr><td>4:</td><td>10.7x</td><td>↖</td></tr> <tr><td>5:</td><td>10.2</td><td>↑</td></tr> <tr><td colspan="2">Serie</td><td>49.0</td></tr> <tr><td colspan="2">Total</td><td>99.0</td></tr> </table>	1:	10.8x	↙	2:	10.1	→	3:	9.7	→	4:	10.7x	↖	5:	10.2	↑	Serie		49.0	Total		99.0	<p>3. Serie 5 Skott</p>  <table border="1" style="width:100%; border-collapse: collapse;"> <tr><td>1:</td><td>10.9x</td><td>↗</td></tr> <tr><td>2:</td><td>9.2</td><td>↖</td></tr> <tr><td>3:</td><td>10.2</td><td>↓</td></tr> <tr><td>4:</td><td>10.4x</td><td>↗</td></tr> <tr><td>5:</td><td>10.5x</td><td>→</td></tr> <tr><td colspan="2">Serie</td><td>49.0</td></tr> <tr><td colspan="2">Total</td><td>148.0</td></tr> </table>	1:	10.9x	↗	2:	9.2	↖	3:	10.2	↓	4:	10.4x	↗	5:	10.5x	→	Serie		49.0	Total		148.0	
1:	10.8x	↙																																										
2:	10.1	→																																										
3:	9.7	→																																										
4:	10.7x	↖																																										
5:	10.2	↑																																										
Serie		49.0																																										
Total		99.0																																										
1:	10.9x	↗																																										
2:	9.2	↖																																										
3:	10.2	↓																																										
4:	10.4x	↗																																										
5:	10.5x	→																																										
Serie		49.0																																										
Total		148.0																																										

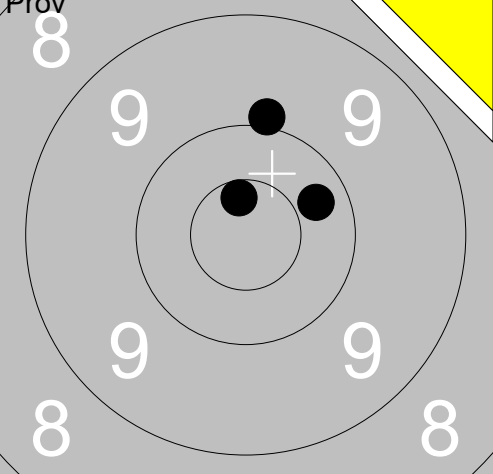
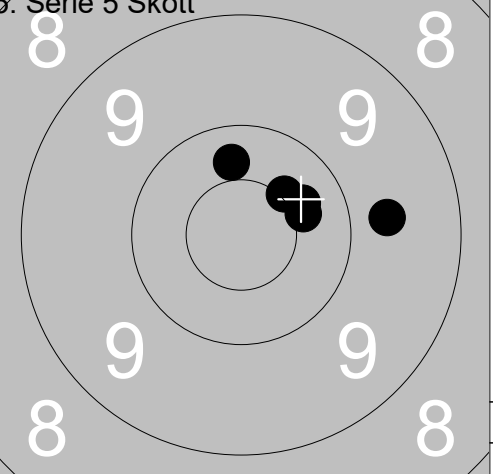
<p>Prov</p>  <table border="1" style="width:100%; border-collapse: collapse;"> <tr><td>1:</td><td>10.6x</td><td>↑</td></tr> <tr><td>2:</td><td>10.3</td><td>↗</td></tr> <tr><td>3:</td><td>9.9</td><td>↑</td></tr> <tr><td colspan="2">Serie</td><td>29.0</td></tr> <tr><td colspan="2">Total</td><td>148.0</td></tr> </table>	1:	10.6x	↑	2:	10.3	↗	3:	9.9	↑	Serie		29.0	Total		148.0	<p>5. Serie 5 Skott</p>  <table border="1" style="width:100%; border-collapse: collapse;"> <tr><td>1:</td><td>10.3</td><td>↑</td></tr> <tr><td>2:</td><td>10.4</td><td>↗</td></tr> <tr><td>3:</td><td>10.5x</td><td>↗</td></tr> <tr><td>4:</td><td>10.4</td><td>↗</td></tr> <tr><td>5:</td><td>9.7</td><td>→</td></tr> <tr><td colspan="2">Serie</td><td>49.0</td></tr> <tr><td colspan="2">Total</td><td>197.0</td></tr> </table>	1:	10.3	↑	2:	10.4	↗	3:	10.5x	↗	4:	10.4	↗	5:	9.7	→	Serie		49.0	Total		197.0	
1:	10.6x	↑																																				
2:	10.3	↗																																				
3:	9.9	↑																																				
Serie		29.0																																				
Total		148.0																																				
1:	10.3	↑																																				
2:	10.4	↗																																				
3:	10.5x	↗																																				
4:	10.4	↗																																				
5:	9.7	→																																				
Serie		49.0																																				
Total		197.0																																				

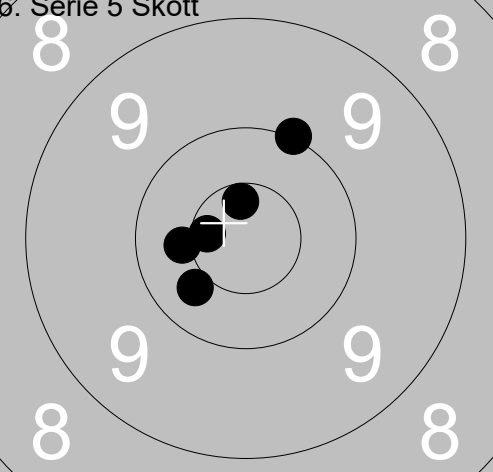
<p>6. Serie 5 Skott</p>  <table border="1" style="width:100%; border-collapse: collapse;"> <tr><td>1:</td><td>10.4</td><td>←</td></tr> <tr><td>2:</td><td>10.4</td><td>↙</td></tr> <tr><td>3:</td><td>10.6x</td><td>↑</td></tr> <tr><td>4:</td><td>10.0</td><td>↗</td></tr> <tr><td>5:</td><td>10.6x</td><td>←</td></tr> <tr><td colspan="2">Serie</td><td>50.0</td></tr> <tr><td colspan="2">Total</td><td>247.0</td></tr> </table>	1:	10.4	←	2:	10.4	↙	3:	10.6x	↑	4:	10.0	↗	5:	10.6x	←	Serie		50.0	Total		247.0		
1:	10.4	←																					
2:	10.4	↙																					
3:	10.6x	↑																					
4:	10.0	↗																					
5:	10.6x	←																					
Serie		50.0																					
Total		247.0																					

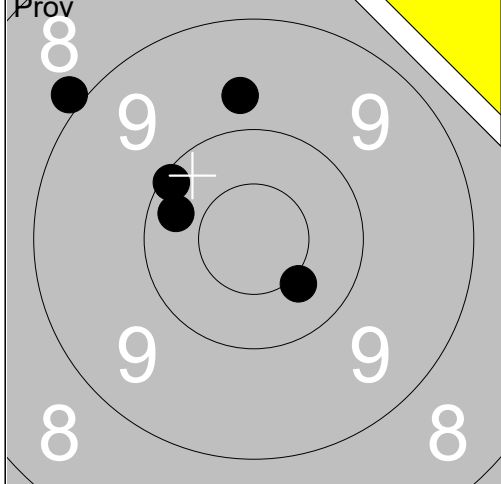

1:	8.9	↗
2:	9.7	↑
3:	10.4x	↘
4:	10.3	↖
5:	10.1	↗
Serie		47.0
Total		0.0

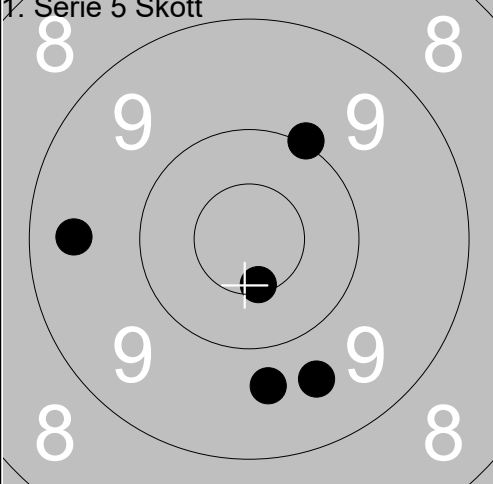

1:	9.4	←
2:	10.6x	↓
3:	9.7	↓
4:	10.0	↗
5:	9.6	↘
Serie		47.0
Total		47.0

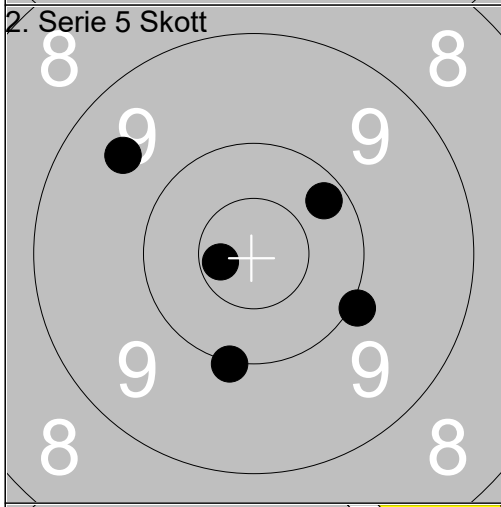

1:	10.0	↘
2:	10.0	↓
3:	9.5	↗
4:	10.2	↗
5:	10.7x	←
Serie		49.0
Total		96.0

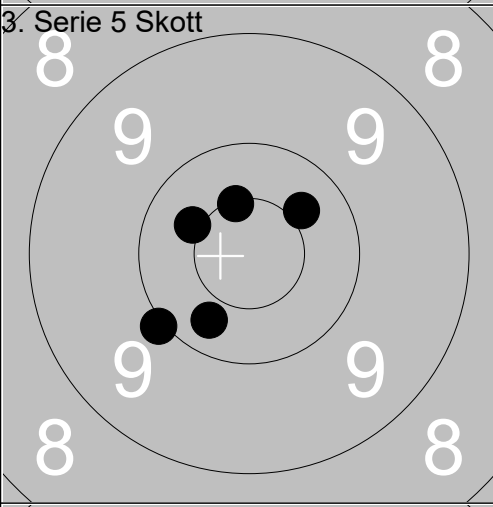

1:	10.3	↘
2:	10.5x	↑
3:	10.4	↗
4:	10.4x	↖
5:	10.0	↘
Serie		50.0
Total		146.0

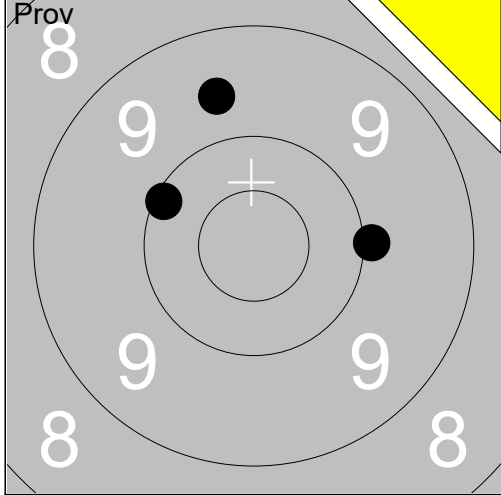

1:	9.6	↑
2:	10.1	↖
3:	10.0	→
Serie		29.0
Total		146.0

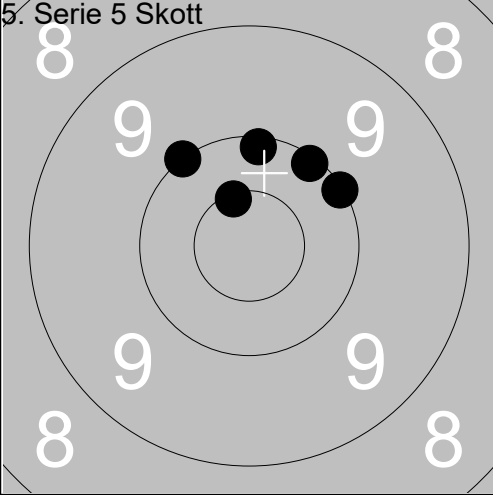

1:	10.1	↗
2:	10.1	↗
3:	10.5x	↑
4:	10.1	↑
5:	10.0	↖
Serie		50.0
Total		196.0

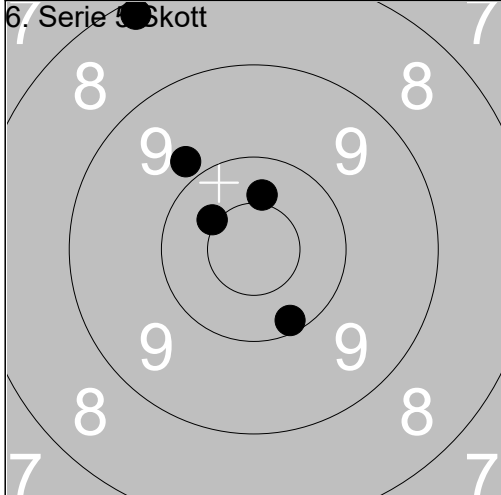

1:	10.2	↓
2:	10.4	↑
3:	9.8	↗
4:	8.2	↗
5:	10.4x	↗
Serie		47.0
Total		243.0

<p>Prov</p>	<p>1. Serie 5 Skott</p>	
1: 8.6 ← 2: 9.7 ← 3: 9.2 ← 4: 9.2 ↗ 5: 10.3 ↗	1: 9.9 ↗ 2: 10.6x ↗ 3: 10.6x ↖ 4: 10.8x ↖ 5: 10.1 ↖	
Serie 45.0 Total 0.0	Serie 49.0 Total 49.0	

<p>2. Serie 5 Skott</p>	<p>3. Serie 5 Skott</p>	
1: 9.9 ↗ 2: 10.4 ↓ 3: 10.2 ↗ 4: 10.0 ← 5: 9.7 →	1: 9.7 ← 2: 10.0 ↗ 3: 10.1 ← 4: 9.9 ↘ 5: 10.4 ↖	
Serie 48.0 Total 97.0	Serie 48.0 Total 145.0	

<p>Prov</p>	<p>4. Serie 5 Skott</p>	
1: 10.8x → 2: 10.5x ↘ 3: 9.9 ↘	1: 9.9 ↘ 2: 10.1 ↗ 3: 10.6x ↘ 4: 10.1 ↗ 5: 9.7 →	
Serie 29.0 Total 145.0	Serie 48.0 Total 193.0	

<p>5. Serie 5 Skott</p>		
1: 10.6x ↗ 2: 10.4 ↘ 3: 10.5x ↗ 4: 10.6x ↘ 5: 10.3 ↗		
Serie 50.0 Total 243.0		

<p>Prov</p>	<p>1: 9.2 ↙ 2: 9.7 ← 3: 8.7 ← 4: 9.0 ← 5: 10.1 ←</p>	<p>1. Serie 5 Skott</p>	<p>1: 9.6 ↗ 2: 9.4 ↗ 3: 8.2 ↗ 4: 10.1 ↗ 5: 9.1 ↗</p>
Serie 45.0		Serie 45.0	
Total 0.0		Total 45.0	

<p>2. Serie 5 Skott</p>	<p>1: 10.6x ↘ 2: 10.2 ← 3: 10.4x → 4: 9.6 ← 5: 10.7x →</p>	<p>3. Serie 5 Skott</p>	<p>1: 10.5x ↘ 2: 9.2 ← 3: 10.1 ↘ 4: 8.4 ↘ 5: 9.8 ←</p>
Serie 49.0		Serie 46.0	
Total 94.0		Total 140.0	

<p>Prov</p>	<p>1: 9.6 ↘ 2: 10.1 ↘ 3: 10.4 ←</p>	<p>5. Serie 5 Skott</p>	<p>1: 9.8 ↑ 2: 9.9 → 3: 10.8x ↓ 4: 9.9 ↗ 5: 10.0 ←</p>
Serie 29.0		Serie 47.0	
Total 140.0		Total 187.0	

<p>6. Serie 5 Skott</p>	<p>1: 10.4 ↗ 2: 10.1 ← 3: 10.4x ← 4: 9.9 ← 5: 9.7 ↗</p>		
Serie 48.0			
Total 235.0			



Skjutlag

Tavla

3

13

Dan-Ivan Karlsson

Ramselefors

Ramselefors

C

Vb

07.07.2024

Tavelträffen A 2024

Ramselefors SKF

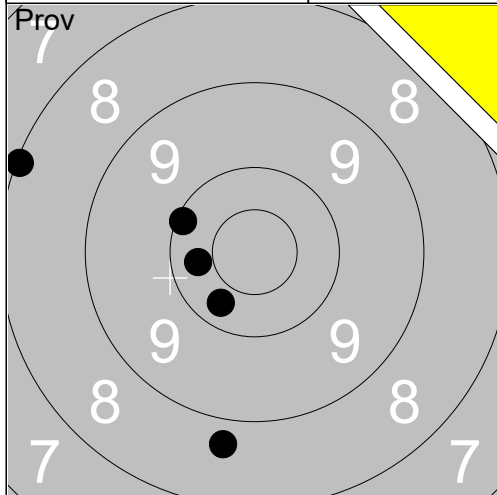

1: 8.1 ↖  
 2: 10.3 ↘  
 3: 10.3 ←  
 4: 8.7 ↘  
 5: 10.1 ↖

Serie 46.0  
 Total 0.0

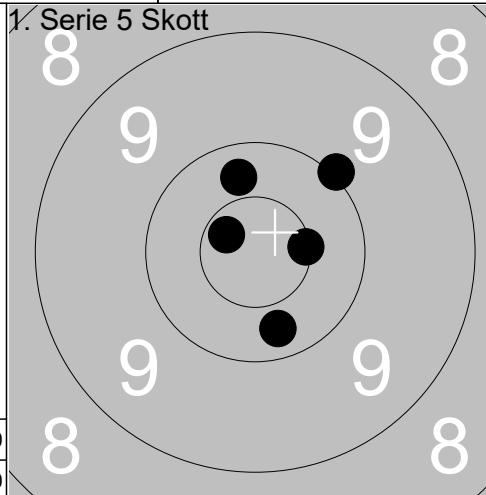

1: 10.3 ↓  
 2: 10.0 ↗  
 3: 10.3 ↑  
 4: 10.5x →  
 5: 10.7x ↖

Serie 50.0  
 Total 50.0

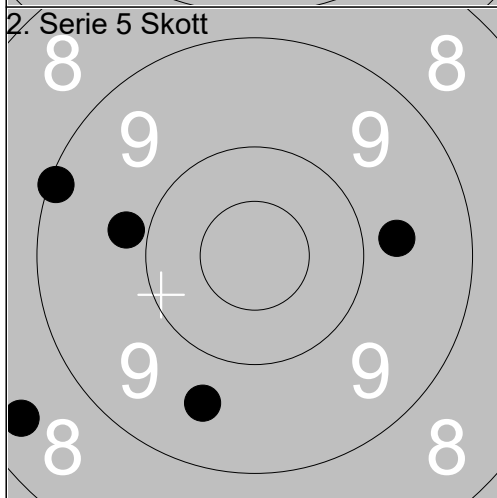

1: 9.6 ↓  
 2: 9.8 ←  
 3: 8.4 ↙  
 4: 9.7 →  
 5: 9.1 ↖

Serie 44.0  
 Total 94.0

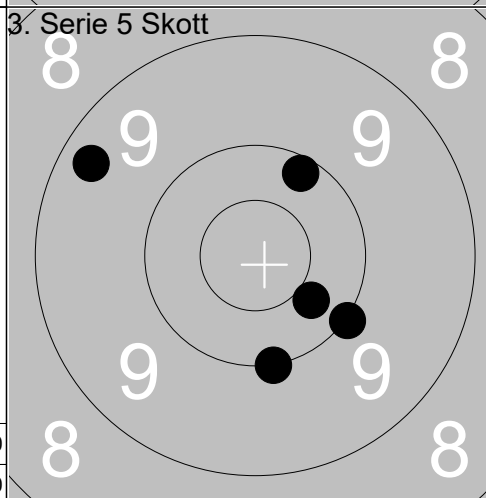

1: 10.0 ↓  
 2: 10.3 ↘  
 3: 10.2 ↗  
 4: 10.0 ↘  
 5: 9.3 ↗

Serie 49.0  
 Total 143.0

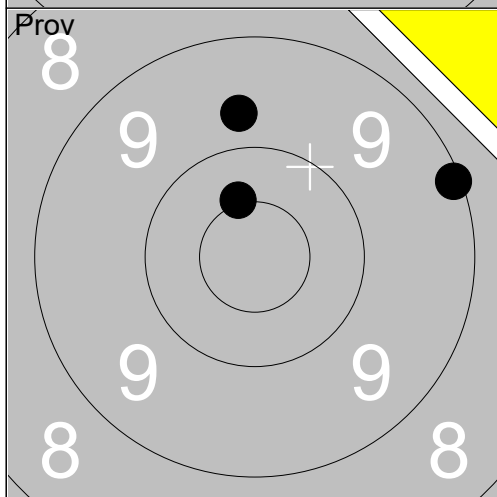

1: 10.5x ↑  
 2: 9.1 →  
 3: 9.7 ↑

Serie 28.0  
 Total 143.0

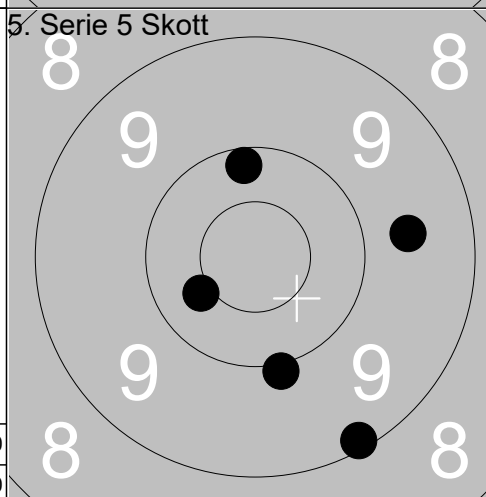

1: 9.6 →  
 2: 10.2 ↑  
 3: 10.0 ↓  
 4: 9.1 ↘  
 5: 10.4 ↖

Serie 48.0  
 Total 191.0

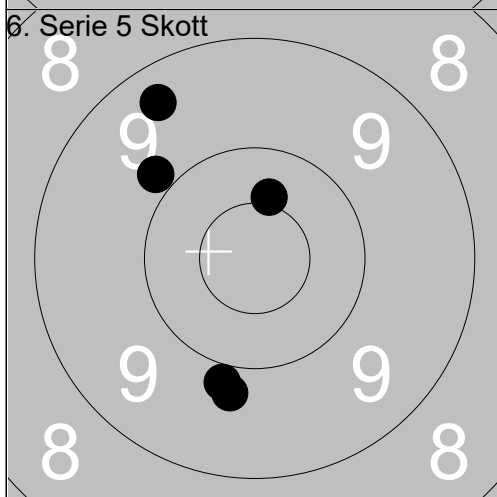

1: 9.4 ↗  
 2: 10.4x ↑  
 3: 9.9 ↘  
 4: 9.8 ↖  
 5: 9.8 ↓

Serie 46.0  
 Total 237.0

<p>Prov</p>	<p>1: 7.6 ← 2: 8.5 ↗ 3: 10.5x ← 4: 9.0 ↗ 5: 10.4 ↗</p>	<p>1. Serie 5 Skott</p>	<p>1: 10.2 ↑ 2: 9.8 ↗ 3: 10.1 ↗ 4: 10.5x ↗ 5: 9.1 ↗</p>								
<table style="width:100%; border-collapse: collapse;"> <tr> <td style="width:80%;">Serie</td> <td style="text-align:right;">44.0</td> </tr> <tr> <td>Total</td> <td style="text-align:right;">0.0</td> </tr> </table>		Serie	44.0	Total	0.0	<table style="width:100%; border-collapse: collapse;"> <tr> <td style="width:80%;">Serie</td> <td style="text-align:right;">48.0</td> </tr> <tr> <td>Total</td> <td style="text-align:right;">48.0</td> </tr> </table>		Serie	48.0	Total	48.0
Serie	44.0										
Total	0.0										
Serie	48.0										
Total	48.0										

<p>2. Serie 5 Skott</p>	<p>1: 8.1 ↓ 2: 10.7x ↗ 3: 9.7 ↓ 4: 10.8x ↗ 5: 10.0 ↓</p>	<p>3. Serie 5 Skott</p>	<p>1: 9.4 ↖ 2: 10.3 ↗ 3: 10.8x ↗ 4: 10.4x → 5: 10.2 ↓</p>								
<table style="width:100%; border-collapse: collapse;"> <tr> <td style="width:80%;">Serie</td> <td style="text-align:right;">47.0</td> </tr> <tr> <td>Total</td> <td style="text-align:right;">95.0</td> </tr> </table>		Serie	47.0	Total	95.0	<table style="width:100%; border-collapse: collapse;"> <tr> <td style="width:80%;">Serie</td> <td style="text-align:right;">49.0</td> </tr> <tr> <td>Total</td> <td style="text-align:right;">144.0</td> </tr> </table>		Serie	49.0	Total	144.0
Serie	47.0										
Total	95.0										
Serie	49.0										
Total	144.0										

<p>Prov</p>	<p>1: 10.4 ↑ 2: 9.4 → 3: 9.4 →</p>	<p>5. Serie 5 Skott</p>	<p>1: 10.2 ↗ 2: 9.5 ↑ 3: 9.7 ↖ 4: 10.7x ↑ 5: 10.6x ↓</p>								
<table style="width:100%; border-collapse: collapse;"> <tr> <td style="width:80%;">Serie</td> <td style="text-align:right;">28.0</td> </tr> <tr> <td>Total</td> <td style="text-align:right;">144.0</td> </tr> </table>		Serie	28.0	Total	144.0	<table style="width:100%; border-collapse: collapse;"> <tr> <td style="width:80%;">Serie</td> <td style="text-align:right;">48.0</td> </tr> <tr> <td>Total</td> <td style="text-align:right;">192.0</td> </tr> </table>		Serie	48.0	Total	192.0
Serie	28.0										
Total	144.0										
Serie	48.0										
Total	192.0										

<p>6. Serie 5 Skott</p>	<p>1: 10.0 ↓ 2: 10.6x ↓ 3: 10.8x ↓ 4: 9.7 ↖ 5: 9.5 ↖</p>						
<table style="width:100%; border-collapse: collapse;"> <tr> <td style="width:80%;">Serie</td> <td style="text-align:right;">48.0</td> </tr> <tr> <td>Total</td> <td style="text-align:right;">240.0</td> </tr> </table>		Serie	48.0	Total	240.0		
Serie	48.0						
Total	240.0						

<p>Prov</p>	<p>1: 8.6 ← 2: 9.7 ← 3: 9.3 ↗ 4: 10.6x ↘ 5: 9.6 ↓</p>	<p>1. Serie 5 Skott</p>	<p>1: 10.4x → 2: 9.6 ← 3: 10.6x ← 4: 9.6 ← 5: 9.4 ↓</p>
<p>Serie 45.0</p>		<p>Serie 47.0</p>	
<p>Total 0.0</p>		<p>Total 47.0</p>	

<p>2. Serie 5 Skott</p>	<p>1: 10.2 ↗ 2: 10.2 ↖ 3: 10.3 ↗ 4: 10.6x ← 5: 10.0 ←</p>	<p>3. Serie 5 Skott</p>	<p>1: 10.7x → 2: 9.8 ← 3: 10.5x ↗ 4: 10.3 ← 5: 10.4 ←</p>
<p>Serie 50.0</p>		<p>Serie 49.0</p>	
<p>Total 97.0</p>		<p>Total 146.0</p>	

<p>Prov</p>	<p>1: 10.1 → 2: 9.3 ↗ 3: 9.7 ↖</p>	<p>5. Serie 5 Skott</p>	<p>1: 9.7 → 2: 10.3 → 3: 9.9 ↘ 4: 10.1 → 5: 10.4 ↘</p>
<p>Serie 28.0</p>		<p>Serie 48.0</p>	
<p>Total 146.0</p>		<p>Total 194.0</p>	

<p>6. Serie 5 Skott</p>	<p>1: 9.7 ← 2: 10.2 ↓ 3: 9.1 ↘ 4: 9.4 → 5: 10.3 ↓</p>		
<p>Serie 47.0</p>			
<p>Total 241.0</p>			

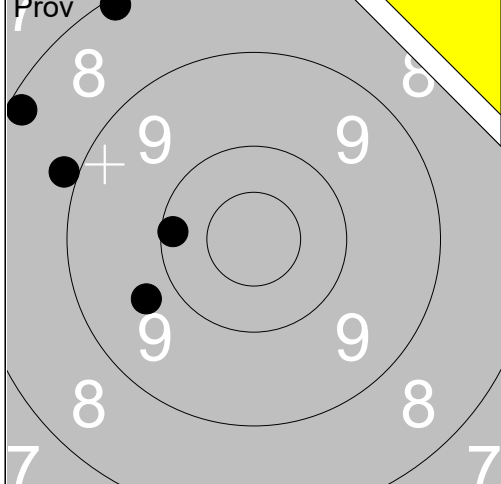

1:	8.1	↗
2:	8.2	↗
3:	8.9	↗
4:	10.1	↖
5:	9.7	↖
Serie		43.0
Total		0.0

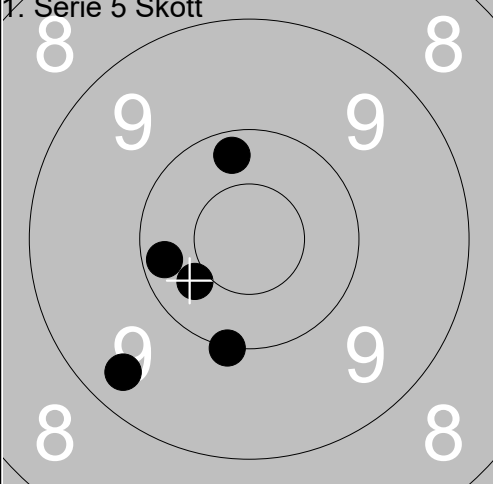

1:	10.2	↑
2:	10.0	↓
3:	9.4	↘
4:	10.4	↘
5:	10.2	←
Serie		49.0
Total		49.0

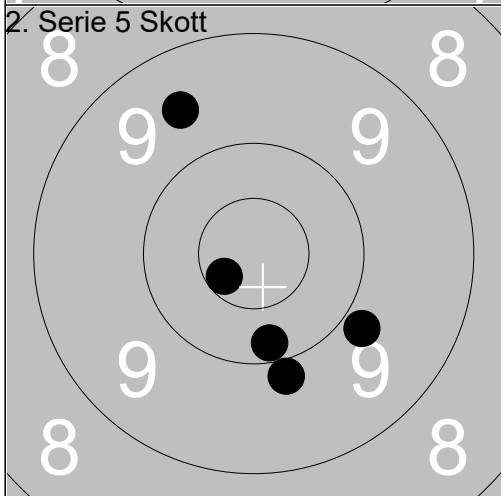

1:	10.6x	↙
2:	9.9	↓
3:	10.2	↘
4:	9.6	↗
5:	9.8	↘
Serie		47.0
Total		96.0

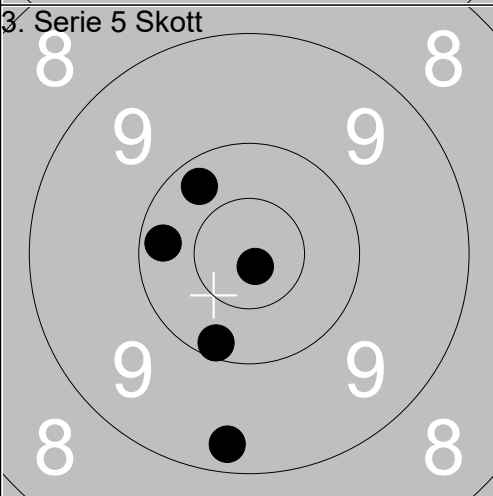

1:	9.3	↓
2:	10.2	↘
3:	10.8x	↘
4:	10.2	←
5:	10.2	↗
Serie		49.0
Total		145.0

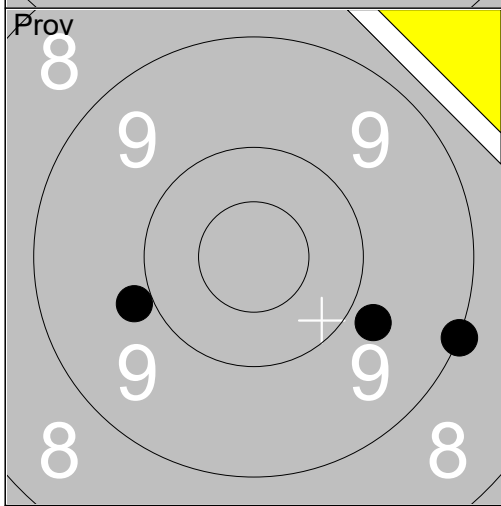

1:	9.8	↘
2:	9.0	→
3:	9.9	←
Serie		27.0
Total		145.0

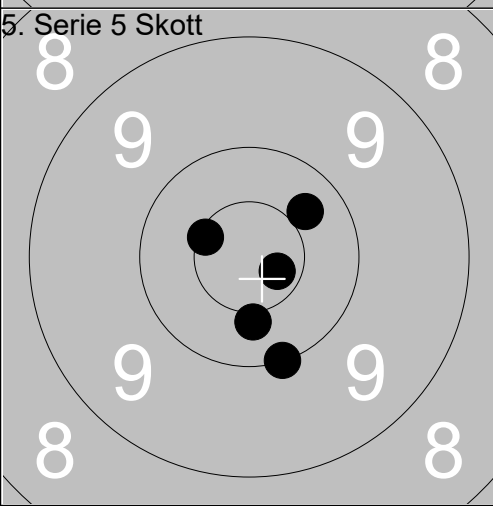

1:	10.0	↓
2:	10.7x	→
3:	10.3	↗
4:	10.4	↓
5:	10.5x	↖
Serie		50.0
Total		195.0

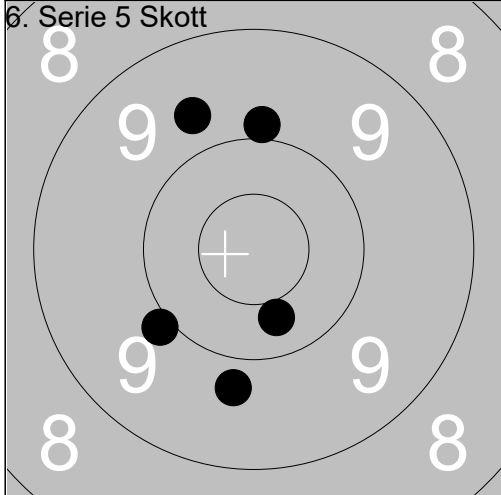

1:	9.7	↗
2:	9.9	↘
3:	9.9	↑
4:	9.8	↓
5:	10.3	↓
Serie		46.0
Total		241.0

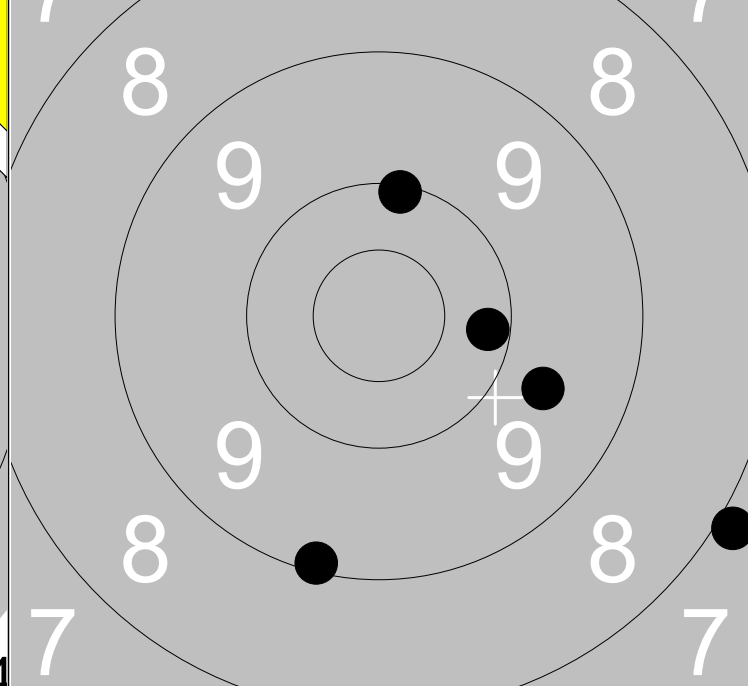
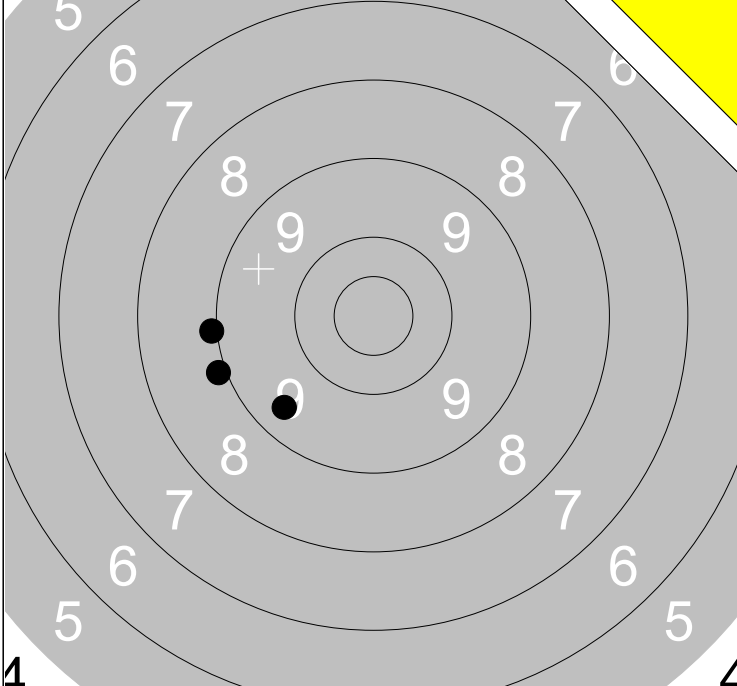

1:	6.4	↑			
2:	9.0	←			
3:	9.4	↙			
4:	8.9	←			

Serie	32				
Total	0				

1:	7.9	→			
2:	9.1	↓			
3:	9.7	→			
4:	10.2	→			
5:	10.1	↑			

Serie	45				
Total	45				

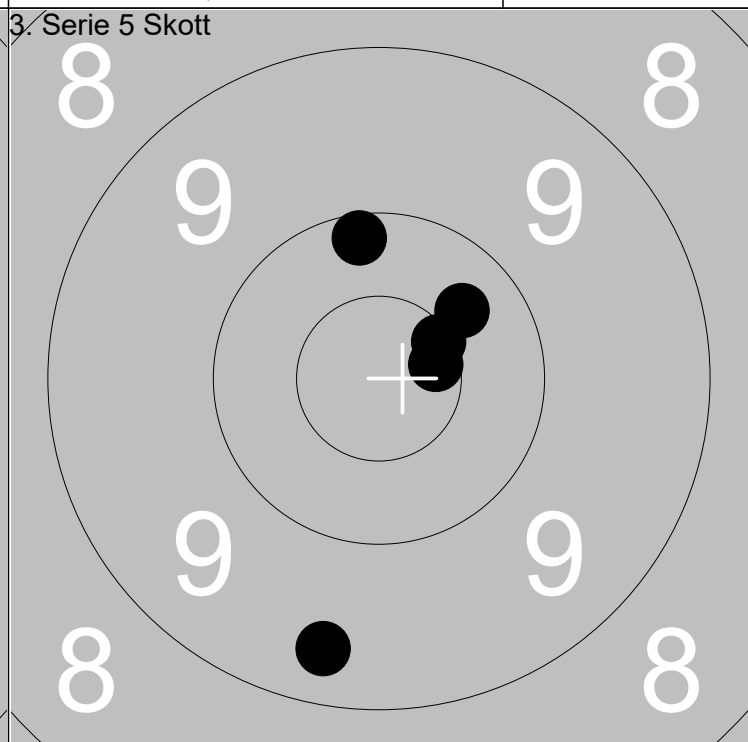
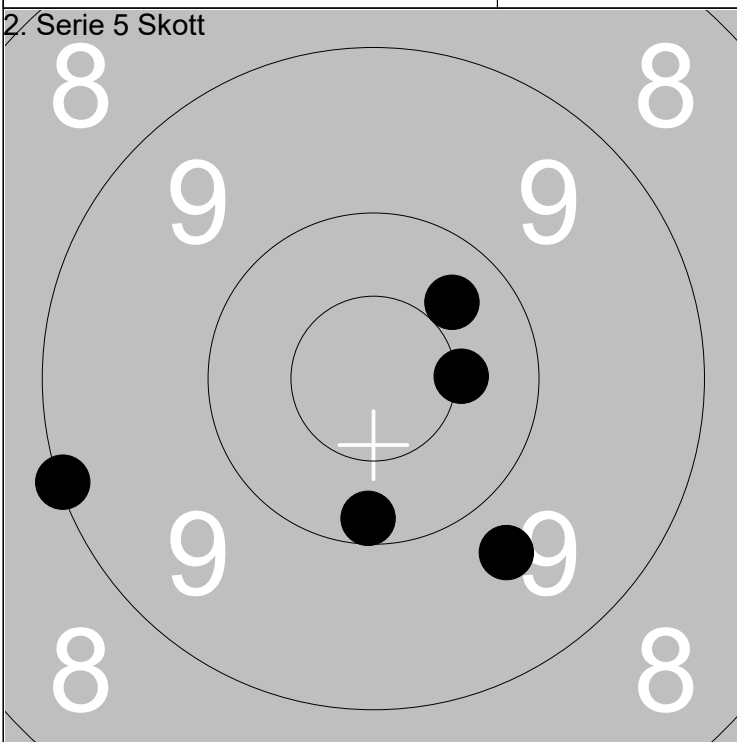

1:	9.1	←			
2:	9.7	↘			
3:	10.2	↓			
4:	10.3	↗			
5:	10.5x	→			

Serie	48				
Total	93				

1:	10.4	↗			
2:	10.2	↑			
3:	10.6x	→			
4:	9.4	↓			
5:	10.6x	↗			

Serie	49				
Total	142				

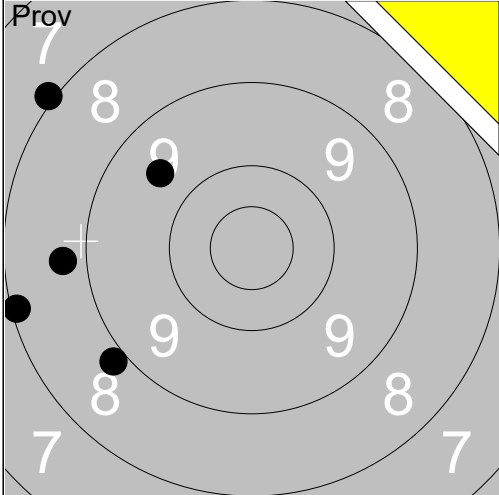
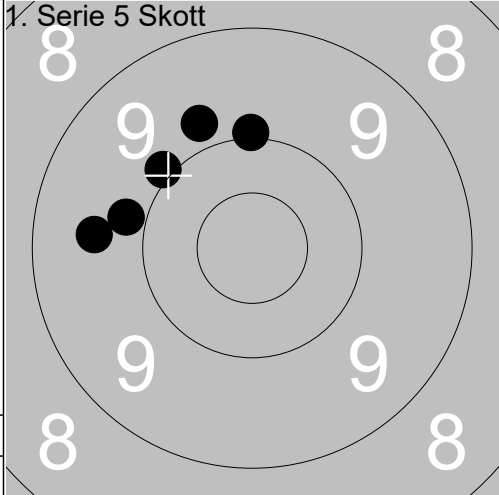
 <p>7 8 8 9 9 8 7</p>	<p>1: 8.9 ↙ 2: 8.1 ← 3: 8.0 ↗ 4: 8.7 ← 5: 9.6 ↗</p>	<p>1. Serie 5 Skott</p>  <p>8 9 9 8 9 9 8</p>	<p>1: 9.9 ↖ 2: 10.0 ↑ 3: 9.8 ↗ 4: 9.8 ← 5: 9.6 ←</p>								
	<table border="1" style="width:100%; border-collapse: collapse;"> <tr><td style="width:50%;">Serie</td><td style="text-align: right;">41.0</td></tr> <tr><td>Total</td><td style="text-align: right;">0.0</td></tr> </table>	Serie	41.0	Total	0.0		<table border="1" style="width:100%; border-collapse: collapse;"> <tr><td style="width:50%;">Serie</td><td style="text-align: right;">46.0</td></tr> <tr><td>Total</td><td style="text-align: right;">46.0</td></tr> </table>	Serie	46.0	Total	46.0
Serie	41.0										
Total	0.0										
Serie	46.0										
Total	46.0										

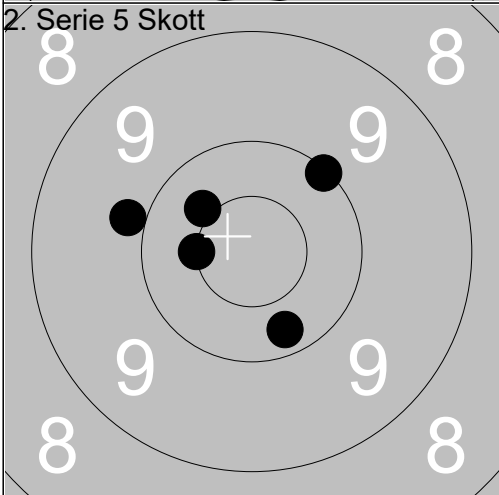
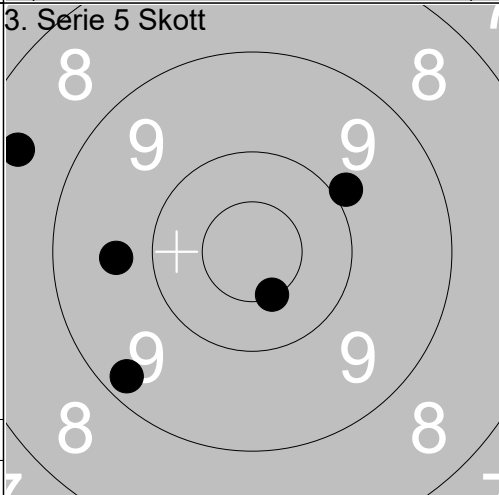
<p>2. Serie 5 Skott</p>  <p>8 9 9 8 9 9 8</p>	<p>1: 10.2 ↓ 2: 10.5x ← 3: 10.1 ↗ 4: 10.4 ↗ 5: 9.9 ←</p>	<p>3. Serie 5 Skott</p>  <p>8 9 9 8 9 9 8</p>	<p>1: 9.9 ↗ 2: 10.5x ↓ 3: 9.3 ↙ 4: 8.5 ← 5: 9.7 ←</p>								
	<table border="1" style="width:100%; border-collapse: collapse;"> <tr><td style="width:50%;">Serie</td><td style="text-align: right;">49.0</td></tr> <tr><td>Total</td><td style="text-align: right;">95.0</td></tr> </table>	Serie	49.0	Total	95.0		<table border="1" style="width:100%; border-collapse: collapse;"> <tr><td style="width:50%;">Serie</td><td style="text-align: right;">45.0</td></tr> <tr><td>Total</td><td style="text-align: right;">140.0</td></tr> </table>	Serie	45.0	Total	140.0
Serie	49.0										
Total	95.0										
Serie	45.0										
Total	140.0										

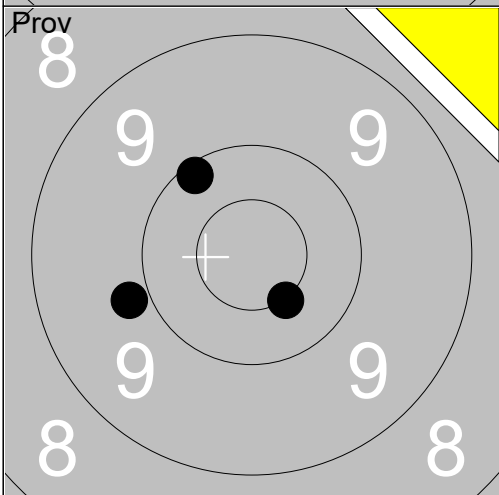
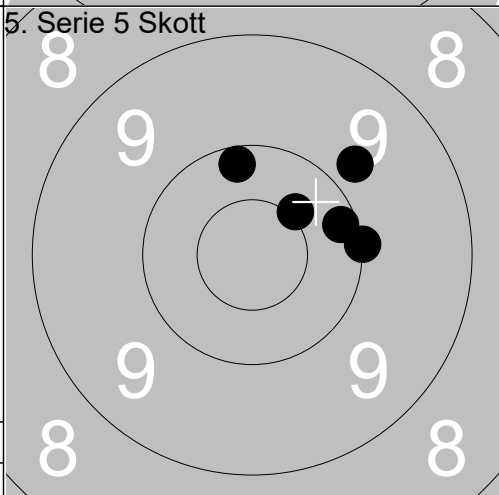
<p>Provschytte</p>  <p>8 9 9 8 9 9 8</p>	<p>1: 10.5x ↓ 2: 10.1 ↗ 3: 9.8 ←</p>	<p>5. Serie 5 Skott</p>  <p>8 9 9 8 9 9 8</p>	<p>1: 9.8 ↗ 2: 10.4x ↗ 3: 10.2 ↑ 4: 10.0 → 5: 10.2 →</p>								
	<table border="1" style="width:100%; border-collapse: collapse;"> <tr><td style="width:50%;">Serie</td><td style="text-align: right;">29.0</td></tr> <tr><td>Total</td><td style="text-align: right;">140.0</td></tr> </table>	Serie	29.0	Total	140.0		<table border="1" style="width:100%; border-collapse: collapse;"> <tr><td style="width:50%;">Serie</td><td style="text-align: right;">49.0</td></tr> <tr><td>Total</td><td style="text-align: right;">189.0</td></tr> </table>	Serie	49.0	Total	189.0
Serie	29.0										
Total	140.0										
Serie	49.0										
Total	189.0										

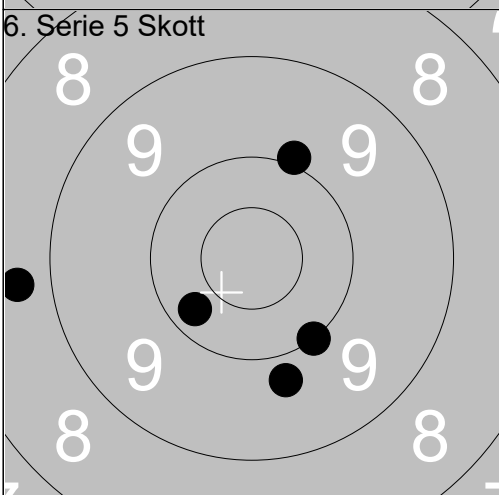
<p>6. Serie 5 Skott</p>  <p>8 9 9 8 9 9 8</p>	<p>1: 8.7 ← 2: 10.0 ↓ 3: 10.3 ↙ 4: 9.9 ↗ 5: 9.8 ↓</p>						
	<table border="1" style="width:100%; border-collapse: collapse;"> <tr><td style="width:50%;">Serie</td><td style="text-align: right;">46.0</td></tr> <tr><td>Total</td><td style="text-align: right;">235.0</td></tr> </table>	Serie	46.0	Total	235.0		
Serie	46.0						
Total	235.0						

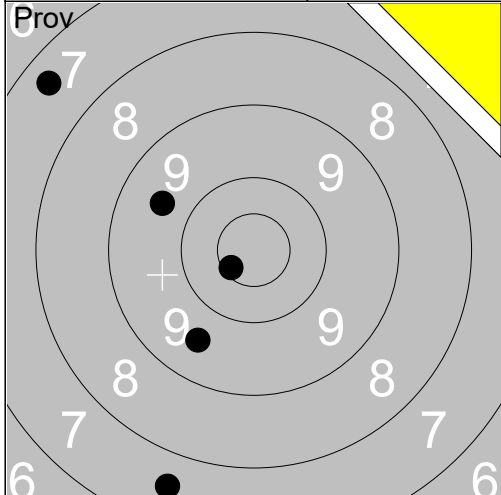

1:	7.4	↖
2:	7.6	↓
3:	10.6x	↙
4:	9.6	↖
5:	9.6	↓

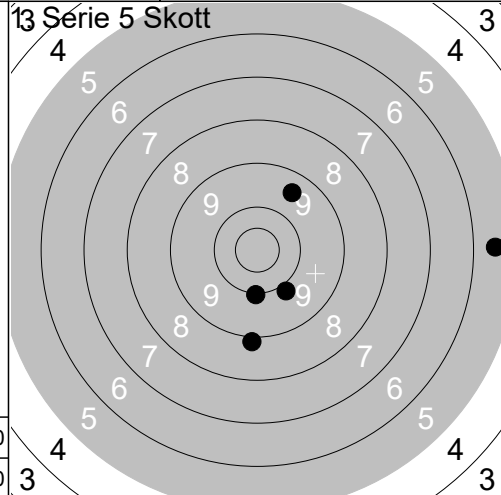

1:	9.5	↗
2:	10.0	↓
3:	8.9	↓
4:	9.9	↘
5:	5.5	→

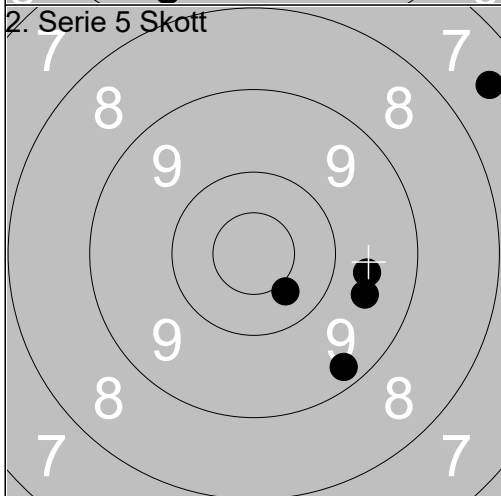

1:	10.4	↘
2:	9.6	→
3:	9.3	↘
4:	7.5	↗
5:	9.6	→

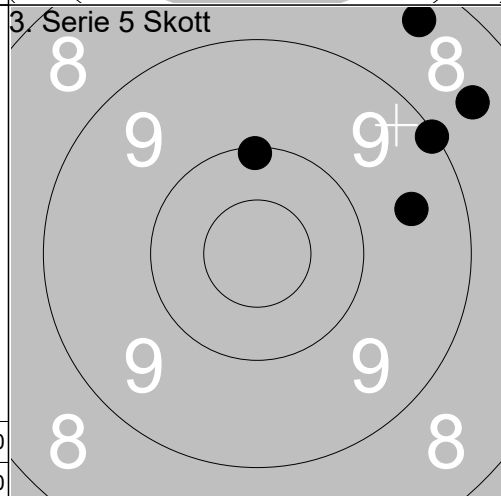

1:	8.6	↗
2:	10.1	↑
3:	9.1	↗
4:	8.4	↗
5:	9.5	→

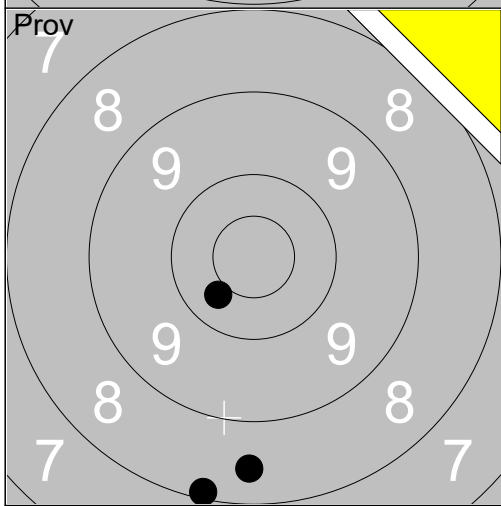

1:	10.4	↘
2:	8.1	↓
3:	8.5	↓

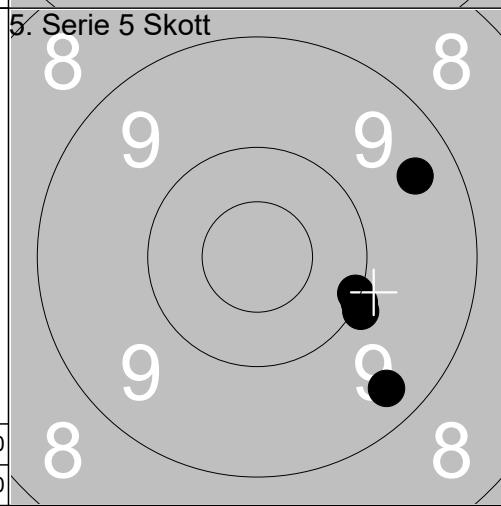

1:	9.4	↗
2:	10.0	↘
3:	9.4	↘
4:	10.1	↘
5:	10.0	↘

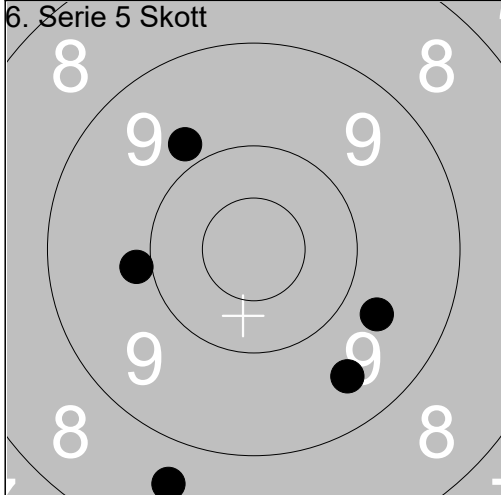

1:	9.9	←
2:	9.5	↘
3:	9.8	↗
4:	9.7	↘
5:	8.6	↓

Serie	42.0
Total	0.0
Serie	41.0
Total	41.0
Serie	44.0
Total	85.0
Serie	26.0
Total	129.0
Serie	48.0
Total	177.0
Serie	44.0
Total	221.0

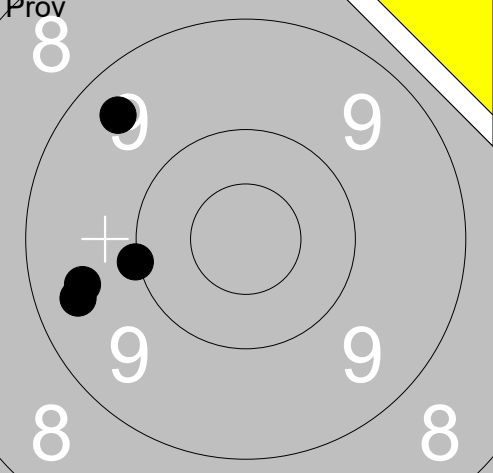
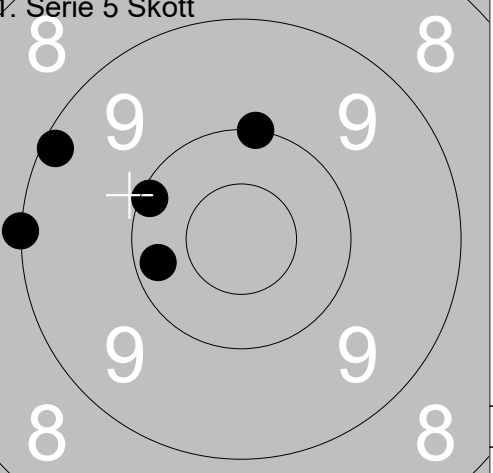
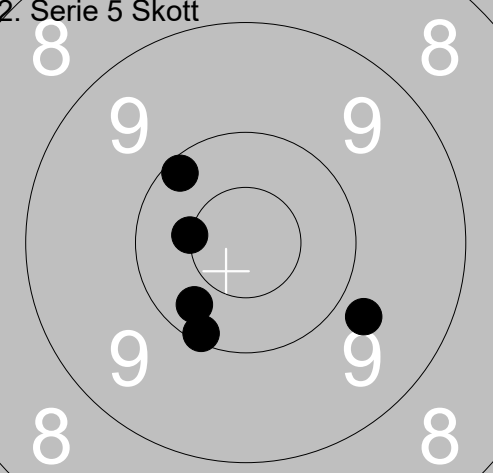
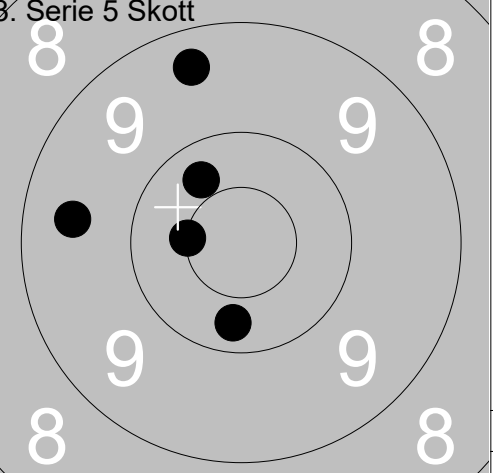
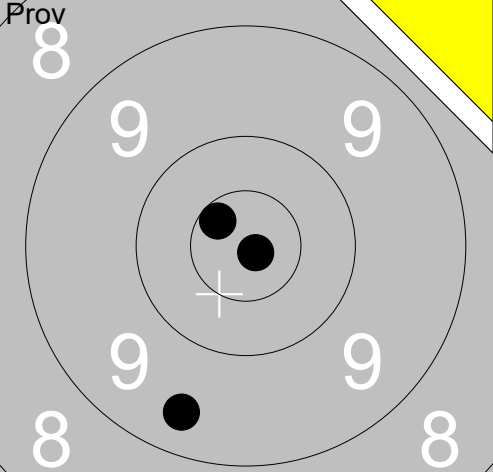
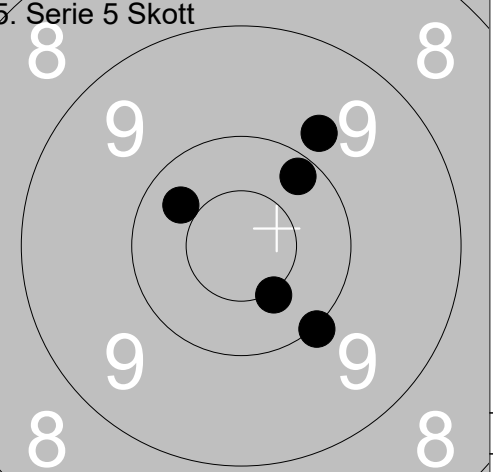
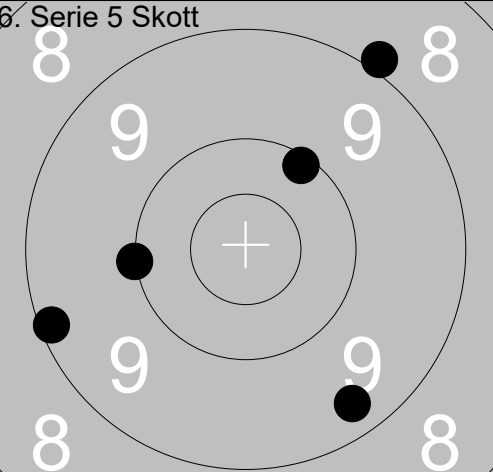
<p>Prov</p>  <p style="text-align: right;">Serie 37.0 Total 0.0</p>	<p>1. Serie 5 Skott</p>  <p style="text-align: right;">Serie 48.0 Total 48.0</p>	<table style="width:100%; border-collapse: collapse;"> <tr><td>1: 10.0</td><td>←</td></tr> <tr><td>2: 9.4</td><td>←</td></tr> <tr><td>3: 9.4</td><td>↗</td></tr> <tr><td>4: 9.5</td><td>←</td></tr> </table> <table style="width:100%; border-collapse: collapse;"> <tr><td>1: 9.1</td><td>↖</td></tr> <tr><td>2: 10.1</td><td>↖</td></tr> <tr><td>3: 9.0</td><td>←</td></tr> <tr><td>4: 10.0</td><td>↑</td></tr> <tr><td>5: 10.2</td><td>←</td></tr> </table>	1: 10.0	←	2: 9.4	←	3: 9.4	↗	4: 9.5	←	1: 9.1	↖	2: 10.1	↖	3: 9.0	←	4: 10.0	↑	5: 10.2	←		
1: 10.0	←																					
2: 9.4	←																					
3: 9.4	↗																					
4: 9.5	←																					
1: 9.1	↖																					
2: 10.1	↖																					
3: 9.0	←																					
4: 10.0	↑																					
5: 10.2	←																					
<p>2. Serie 5 Skott</p>  <p style="text-align: right;">Serie 49.0 Total 97.0</p>	<p>3. Serie 5 Skott</p>  <p style="text-align: right;">Serie 48.0 Total 145.0</p>	<table style="width:100%; border-collapse: collapse;"> <tr><td>1: 10.1</td><td>↗</td></tr> <tr><td>2: 10.5x</td><td>←</td></tr> <tr><td>3: 9.8</td><td>↘</td></tr> <tr><td>4: 10.1</td><td>↘</td></tr> <tr><td>5: 10.3</td><td>↘</td></tr> </table> <table style="width:100%; border-collapse: collapse;"> <tr><td>1: 10.3</td><td>↓</td></tr> <tr><td>2: 9.5</td><td>←</td></tr> <tr><td>3: 10.5x</td><td>←</td></tr> <tr><td>4: 9.4</td><td>↗</td></tr> <tr><td>5: 10.3</td><td>↗</td></tr> </table>	1: 10.1	↗	2: 10.5x	←	3: 9.8	↘	4: 10.1	↘	5: 10.3	↘	1: 10.3	↓	2: 9.5	←	3: 10.5x	←	4: 9.4	↗	5: 10.3	↗
1: 10.1	↗																					
2: 10.5x	←																					
3: 9.8	↘																					
4: 10.1	↘																					
5: 10.3	↘																					
1: 10.3	↓																					
2: 9.5	←																					
3: 10.5x	←																					
4: 9.4	↗																					
5: 10.3	↗																					
<p>Prov</p>  <p style="text-align: right;">Serie 29.0 Total 145.0</p>	<p>5. Serie 5 Skott</p>  <p style="text-align: right;">Serie 49.0 Total 194.0</p>	<table style="width:100%; border-collapse: collapse;"> <tr><td>1: 10.8x</td><td>↘</td></tr> <tr><td>2: 10.6x</td><td>↗</td></tr> <tr><td>3: 9.4</td><td>↘</td></tr> </table> <table style="width:100%; border-collapse: collapse;"> <tr><td>1: 10.3</td><td>↖</td></tr> <tr><td>2: 10.5x</td><td>↘</td></tr> <tr><td>3: 10.2</td><td>↗</td></tr> <tr><td>4: 10.0</td><td>↘</td></tr> <tr><td>5: 9.8</td><td>↗</td></tr> </table>	1: 10.8x	↘	2: 10.6x	↗	3: 9.4	↘	1: 10.3	↖	2: 10.5x	↘	3: 10.2	↗	4: 10.0	↘	5: 9.8	↗				
1: 10.8x	↘																					
2: 10.6x	↗																					
3: 9.4	↘																					
1: 10.3	↖																					
2: 10.5x	↘																					
3: 10.2	↗																					
4: 10.0	↘																					
5: 9.8	↗																					
<p>6. Serie 5 Skott</p>  <p style="text-align: right;">Serie 46.0 Total 240.0</p>																						



<b>Prov</b> 	1: 7.6 ← 2: 8.3 ↗ 3: 8.0 ↗ 4: 9.7 ↑ 5: 9.1 ↓ <hr/> Serie 41.0 Total 0.0	<b>1. Serie 5 Skott</b> 	1: 9.3 → 2: 10.1 ↓ 3: 8.6 ↓ 4: 9.6 ↓ 5: 8.8 ↓ <hr/> Serie 44.0 Total 44.0
-----------------	---	-----------------------------	---

<b>2. Serie 5 Skott</b> 	1: 8.6 ↗ 2: 9.7 ↗ 3: 10.5x ↑ 4: 10.0 → 5: 9.8 ↓ <hr/> Serie 46.0 Total 90.0	<b>3. Serie 5 Skott</b> 	1: 9.2 → 2: 7.4 ↗ 3: 8.9 ↗ 4: 7.4 ↑ 5: 8.8 → <hr/> Serie 39.0 Total 129.0
-----------------------------	---	-----------------------------	---

<b>Prov</b> 	1: 9.6 → 2: 9.0 ← 3: 9.8 → <hr/> Serie 27.0 Total 129.0	<b>5. Serie 5 Skott</b> 	1: 10.0 ↓ 2: 8.8 → 3: 10.1 ↗ 4: 9.0 ↓ 5: 10.4x ↓ <hr/> Serie 47.0 Total 176.0
-----------------	---	-----------------------------	---

<b>6. Serie 5 Skott</b> 	1: 6.7 ↗ 2: 10.1 ↗ 3: 10.6x ↗ 4: 7.1 ↓ 5: 8.3 ↑ <hr/> Serie 41.0 Total 217.0		
-----------------------------	--	--	--