

<p>Prov</p> 	<p>1: 10.3 ↙ 2: 8.7 ↗ 3: 10.3 →</p> <p>Serie 28.0 Total 0.0</p>	<p>1. Serie 5 Skott</p> 	<p>1: 8.7 ↓ 2: 8.0 ↓ 3: 9.7 ↓ 4: 8.9 ↗ 5: 10.2 ↗</p> <p>Serie 43.0 Total 43.0</p>
--	---	--	---

<p>2. Serie 5 Skott</p> 	<p>1: 10.1 ↓ 2: 8.5 ↗ 3: 9.2 ↗ 4: 7.7 ↗ 5: 8.6 ↗</p> <p>Serie 42.0 Total 85.0</p>	<p>3. Serie 5 Skott</p> 	<p>1: 9.3 ↓ 2: 10.7x → 3: 10.2 ↓ 4: 9.4 ← 5: 8.9 ←</p> <p>Serie 46.0 Total 131.0</p>
---	---	---	--

<p>Prov</p> 	<p>1: 9.6 ↗ 2: 10.0 ↑ 3: 10.2 ↑</p> <p>Serie 29.0 Total 131.0</p>	<p>4. Serie 10 Skott</p> 	<p>1: 9.1 ↓ 2: 10.2 → 3: 8.1 ↓ 4: 10.1 ↑ 5: 10.4x ↓</p> <p>Serie 47.0 Total 178.0</p>
--	---	---	---

<p>4. Serie 10 Skott</p> 	<p>6: 10.4 ↑ 7: 9.8 ↓ 8: 10.7x ↑ 9: 8.9 → 10: 10.4 ↗</p> <p>Serie 47.0 Total 225.0</p>		
---	--	--	--

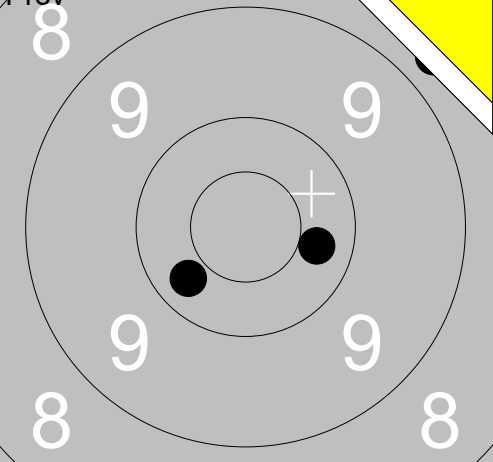
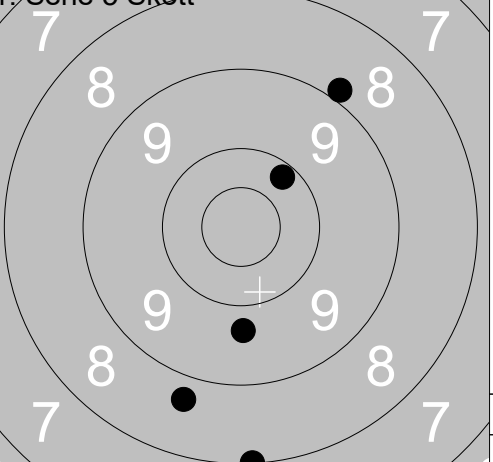
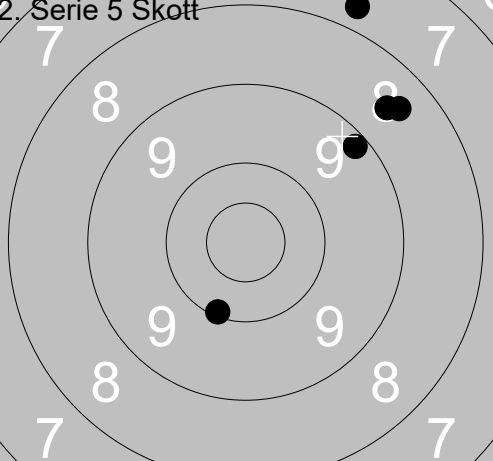
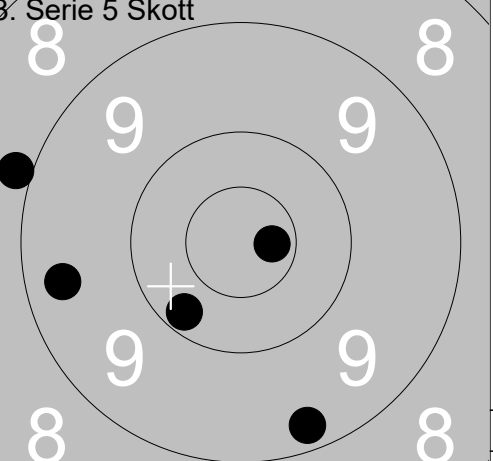
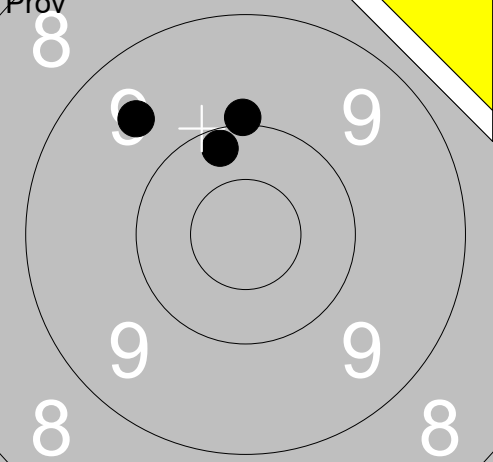
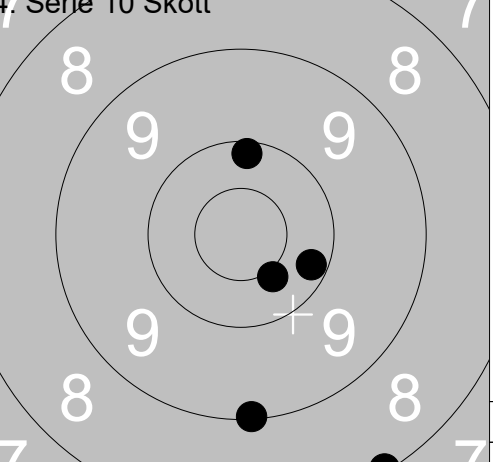
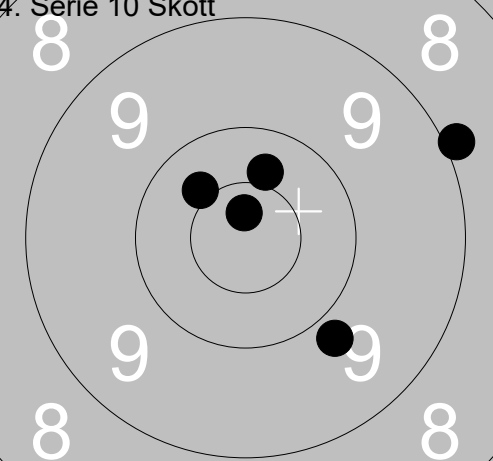
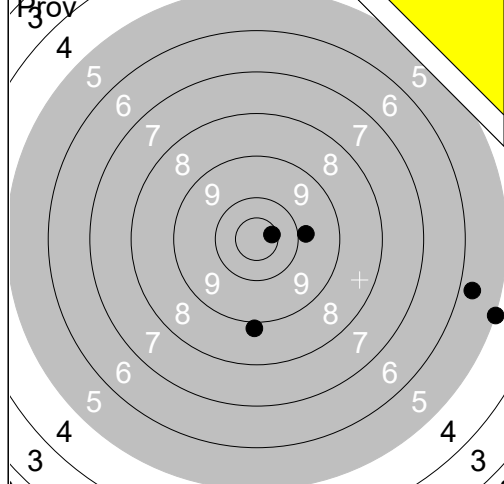

1:	5.0	→
2:	5.7	→
3:	8.9	↓
4:	9.8	→
5:	10.6x	→

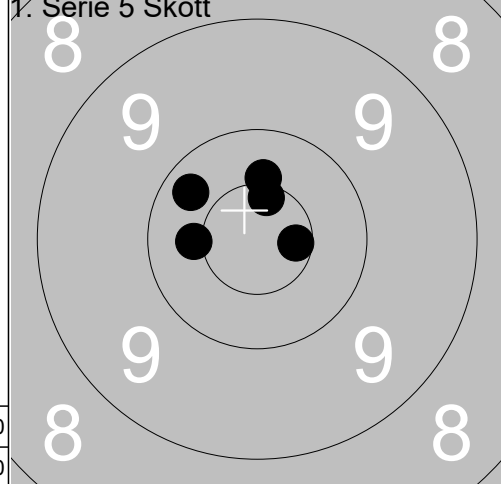

1:	10.6x	↑
2:	10.4x	←
3:	10.3	↖
4:	10.6x	→
5:	10.4x	↑

Serie	37.0
Total	0.0

Serie	50.0
Total	50.0

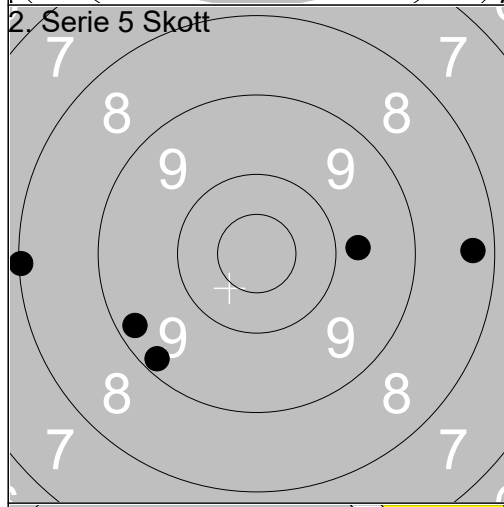

1:	8.1	←
2:	9.2	←
3:	8.3	→
4:	9.2	↙
5:	9.8	→

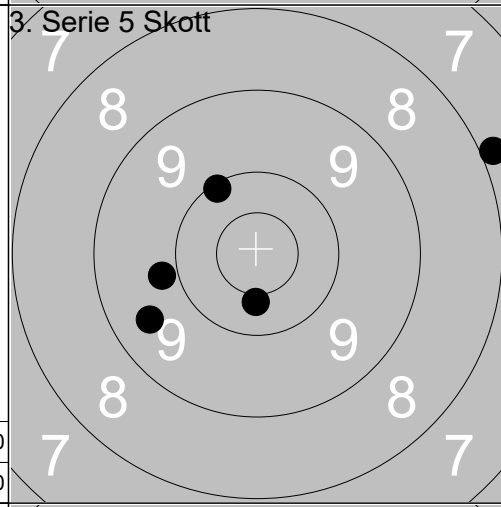

1:	10.1	↖
2:	10.4	↓
3:	9.8	←
4:	9.5	↙
5:	7.9	→

Serie	43.0
Total	93.0

Serie	45.0
Total	138.0

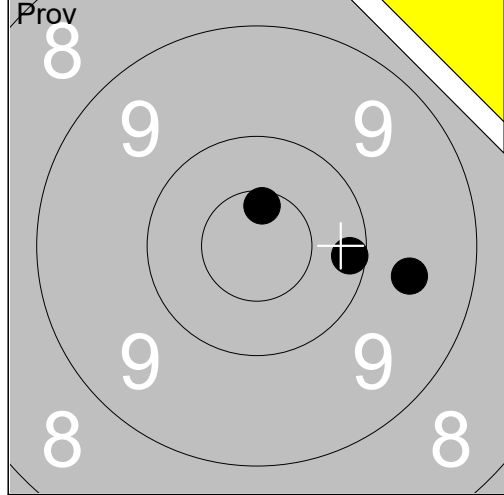

1:	9.6	→
2:	10.6x	↑
3:	10.2	→

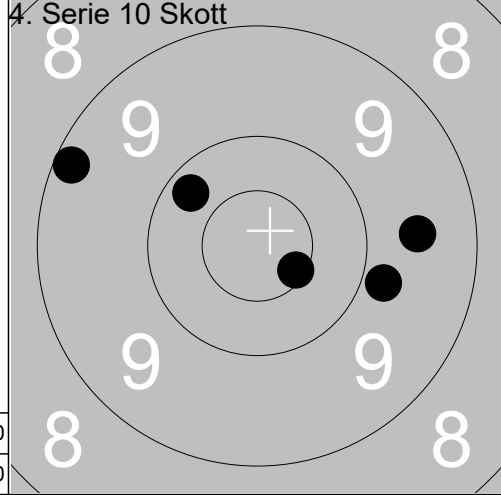

1:	9.2	↖
2:	9.6	→
3:	10.6x	↘
4:	9.8	→
5:	10.2	↗

Serie	29.0
Total	138.0

Serie	47.0
Total	185.0

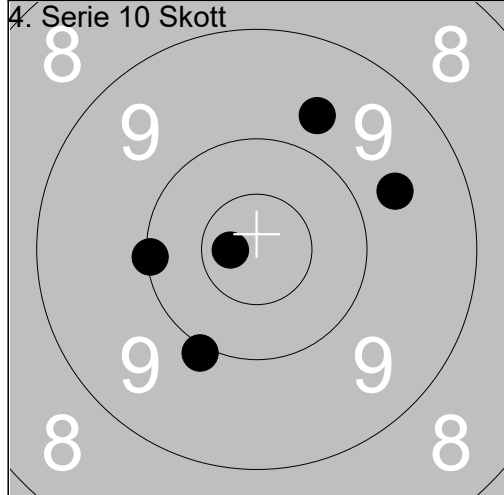

6:	10.0	↘
7:	10.7x	←
8:	9.7	→
9:	9.7	↑
10:	10.1	←

Serie	48.0
Total	233.0

<p>Prov</p>	<p>1. Serie 5 Skott</p>	
Serie 45.0 Total 0.0	Serie 47.0 Total 47.0	

<p>2. Serie 5 Skott</p>	<p>3. Serie 5 Skott</p>	
Serie 42.0 Total 89.0	Serie 44.0 Total 133.0	

<p>Prov</p>	<p>4. Serie 10 Skott</p>	
Serie 27.0 Total 133.0	Serie 43.0 Total 176.0	

<p>4. Serie 10 Skott</p>		
Serie 43.0 Total 219.0		

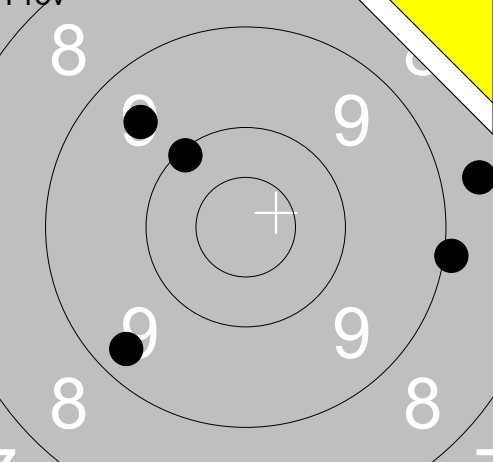
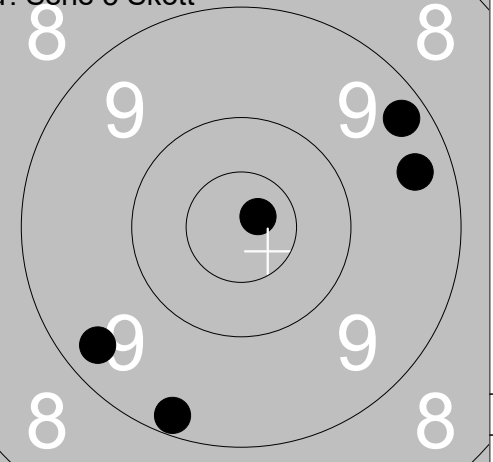
<p>Prov</p> 	<p>1: 9.0 →</p> <p>2: 8.6 →</p> <p>3: 9.5 ↗</p> <p>4: 10.1 ↗</p> <p>5: 9.3 ↘</p>	<p>1. Serie 5 Skott</p> 	<p>1: 9.3 ↙</p> <p>2: 9.2 ↓</p> <p>3: 10.8x ↗</p> <p>4: 9.3 ↗</p> <p>5: 9.4 →</p>
Serie 45.0		Serie 46.0	
Total 0.0		Total 46.0	

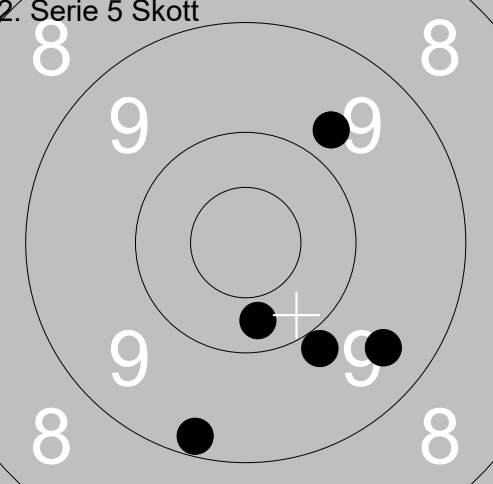
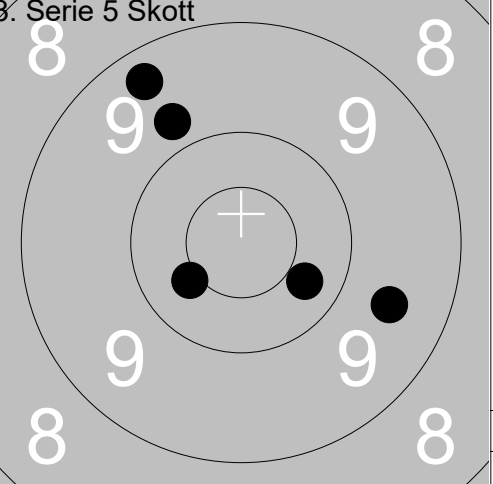
<p>2. Serie 5 Skott</p> 	<p>1: 9.9 ↓</p> <p>2: 10.3 ↓</p> <p>3: 9.7 ↗</p> <p>4: 9.2 ↓</p> <p>5: 9.5 ↘</p>	<p>3. Serie 5 Skott</p> 	<p>1: 10.4x ↙</p> <p>2: 10.3 →</p> <p>3: 9.6 →</p> <p>4: 9.8 ↗</p> <p>5: 9.3 ↗</p>
Serie 46.0		Serie 47.0	
Total 92.0		Total 139.0	

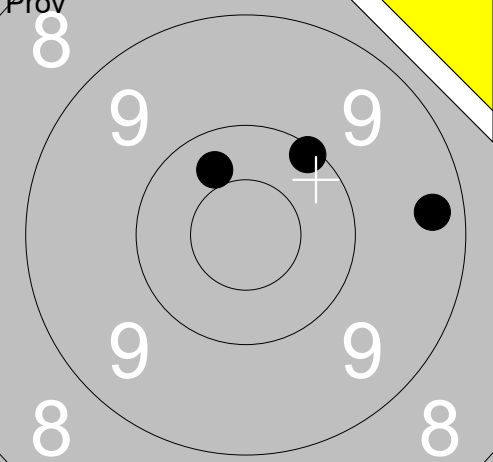
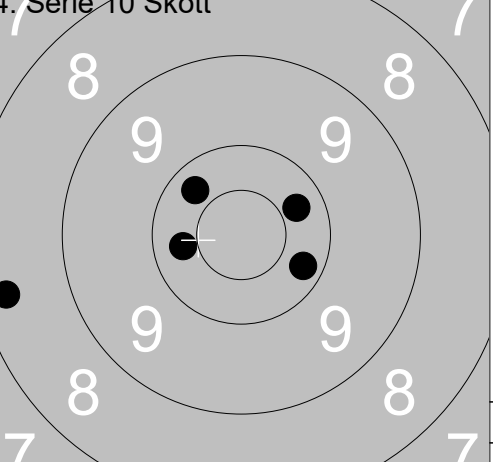
<p>Prov</p> 	<p>1: 9.3 →</p> <p>2: 10.1 ↗</p> <p>3: 10.3 ↗</p>	<p>4. Serie 10 Skott</p> 	<p>1: 8.3 ←</p> <p>2: 10.3 ↗</p> <p>3: 10.2 →</p> <p>4: 10.3 ←</p> <p>5: 10.3 ↗</p>
Serie 29.0		Serie 48.0	
Total 139.0		Total 187.0	

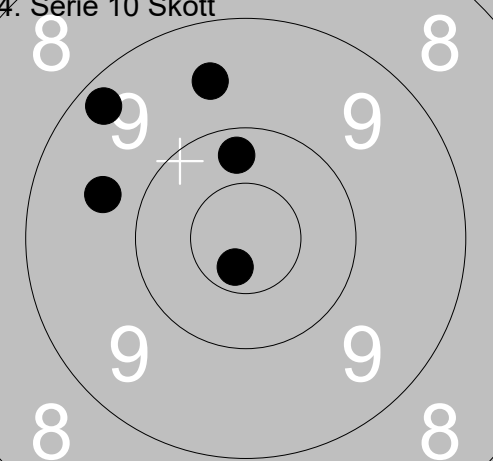
<p>4. Serie 10 Skott</p> 	<p>6: 9.6 ↑</p> <p>7: 9.3 ↗</p> <p>8: 10.7x ↓</p> <p>9: 9.7 ←</p> <p>10: 10.2 ↑</p>		
Serie 47.0			
Total 234.0			

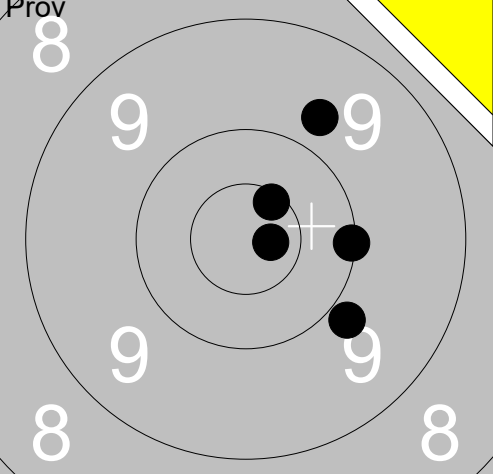
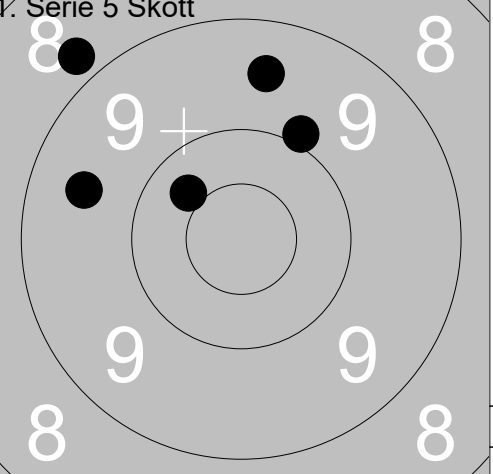
<p>Prov</p> 	<p>1: 9.7 ↗ 2: 10.1 → 3: 10.7x → 4: 10.6x ↗ 5: 9.9 ↘</p>	<p>1. Serie 5 Skott</p> 	<p>1: 9.5 ↗ 2: 8.8 ↗ 3: 10.4 ↗ 4: 9.5 ← 5: 9.9 ↗</p>
Serie 48.0		Serie 45.0	
Total 0.0		Total 45.0	

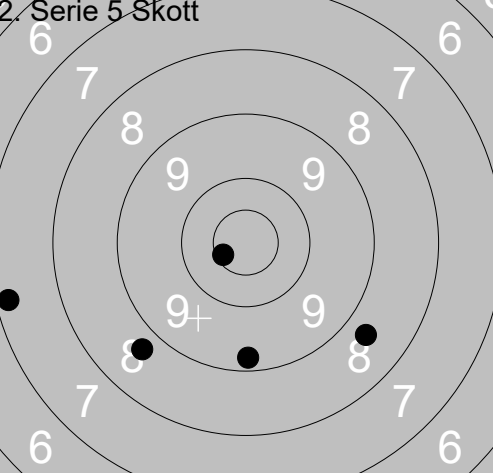
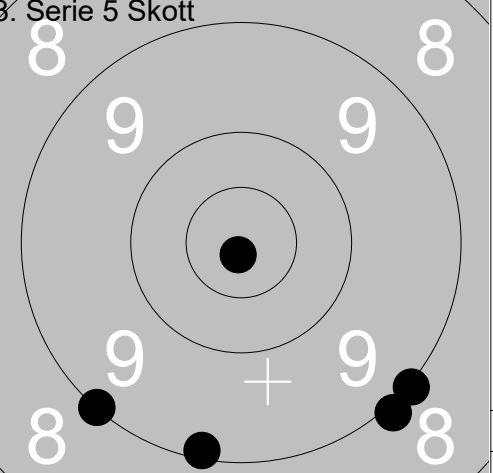
<p>2. Serie 5 Skott</p> 	<p>1: 9.2 ↓ 2: 8.7 ↘ 3: 8.7 ↘ 4: 7.2 ← 5: 10.6x ←</p>	<p>3. Serie 5 Skott</p> 	<p>1: 9.1 ↓ 2: 9.0 ↘ 3: 9.0 ↘ 4: 9.0 ↘ 5: 10.8x ↓</p>
Serie 42.0		Serie 46.0	
Total 87.0		Total 133.0	

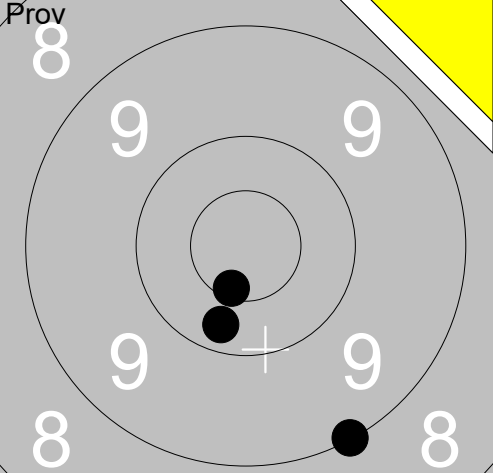
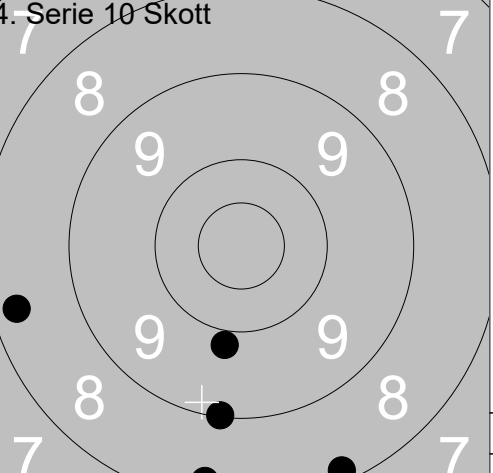
<p>Prov</p> 	<p>1: 10.6x ↓ 2: 10.3 ↓ 3: 9.0 ↓</p>	<p>4. Serie 10 Skott</p> 	<p>1: 8.3 ← 2: 9.0 ↓ 3: 8.2 ↓ 4: 9.9 ↓ 5: 8.3 ↓</p>
Serie 29.0		Serie 42.0	
Total 133.0		Total 175.0	

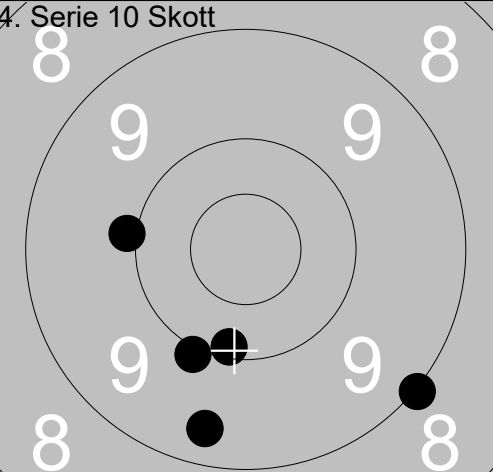
<p>4. Serie 10 Skott</p> 	<p>6: 10.1 ↓ 7: 10.0 ↓ 8: 9.0 ↘ 9: 9.4 ↓ 10: 9.9 ←</p>		
Serie 47.0			
Total 222.0			

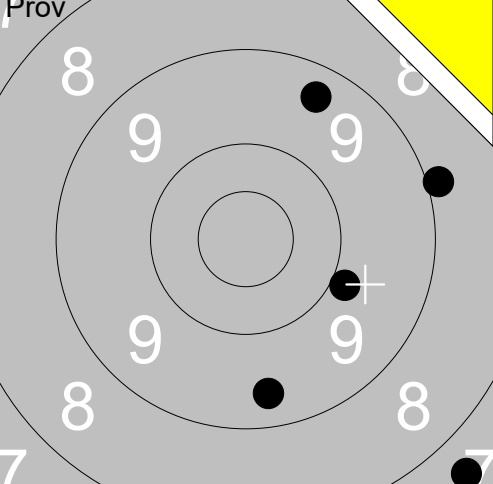
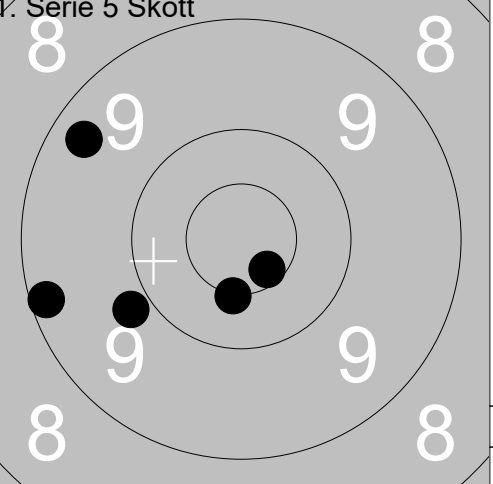
 <p>Prov</p>	<p>1: 7.6 ↘ 2: 9.9 → 3: 8.9 → 4: 9.4 ↓ 5: 9.4 ↗</p>	<p>1. Serie 5 Skott</p> 	<p>1: 10.5x ↓ 2: 9.3 ↗ 3: 9.2 ← 4: 10.6x ↓ 5: 9.8 ↙</p>
<p>Serie 42.0</p>		<p>Serie 47.0</p>	
<p>Total 0.0</p>		<p>Total 47.0</p>	

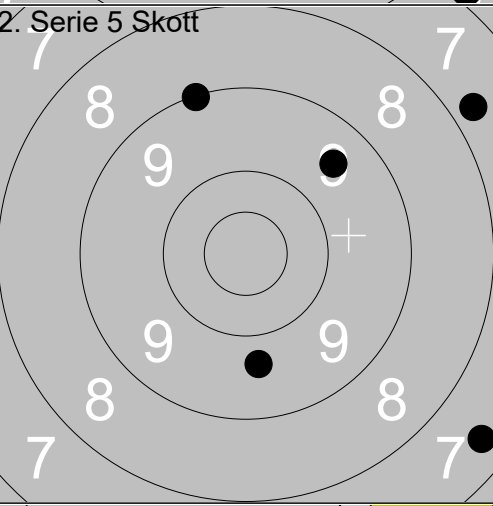
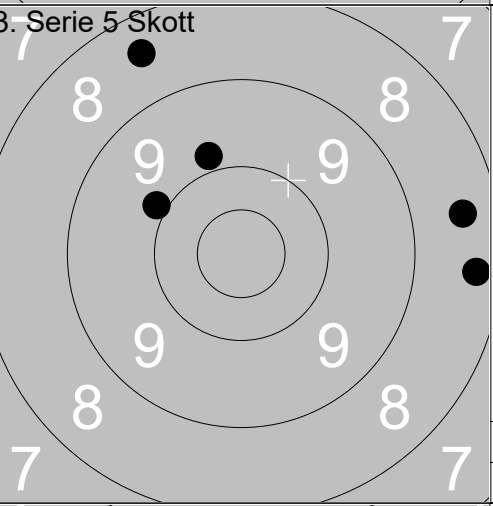
 <p>2. Serie 5 Skott</p>	<p>1: 9.7 ↓ 2: 7.4 ↘ 3: 7.8 ↗ 4: 9.0 ↗ 5: 9.5 ↗</p>	<p>3. Serie 5 Skott</p> 	<p>1: 8.4 → 2: 8.3 → 3: 8.5 ↗ 4: 9.9 ↗ 5: 9.8 ↗</p>
<p>Serie 41.0</p>		<p>Serie 42.0</p>	
<p>Total 88.0</p>		<p>Total 130.0</p>	

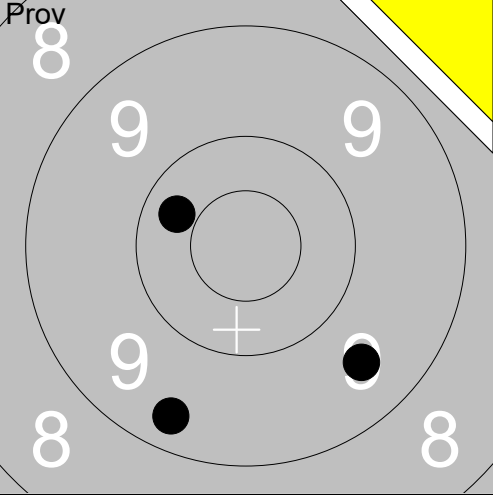
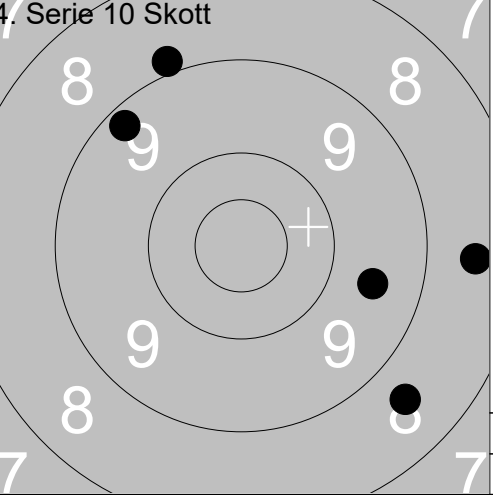
 <p>Prov</p>	<p>1: 9.3 ↓ 2: 10.3 ↗ 3: 9.5 ↓</p>	<p>4. Serie 10 Skott</p> 	<p>1: 9.2 ↗ 2: 8.9 ↗ 3: 8.5 → 4: 8.6 ↓ 5: 9.6 ↓</p>
<p>Serie 28.0</p>		<p>Serie 42.0</p>	
<p>Total 130.0</p>		<p>Total 172.0</p>	

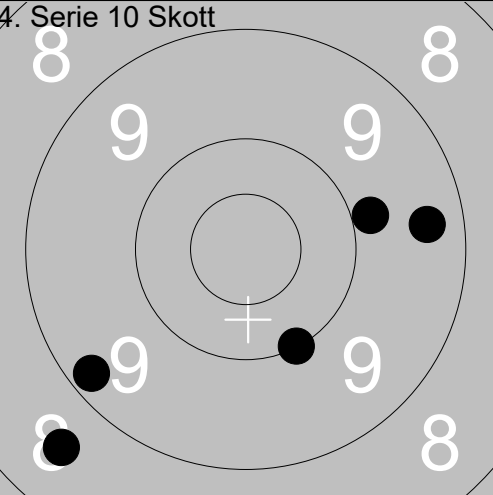
 <p>4. Serie 10 Skott</p>	<p>6: 9.2 ↙ 7: 8.6 ↙ 8: 10.0 ↓ 9: 9.9 → 10: 9.4 →</p>		
<p>Serie 45.0</p>			
<p>Total 217.0</p>			

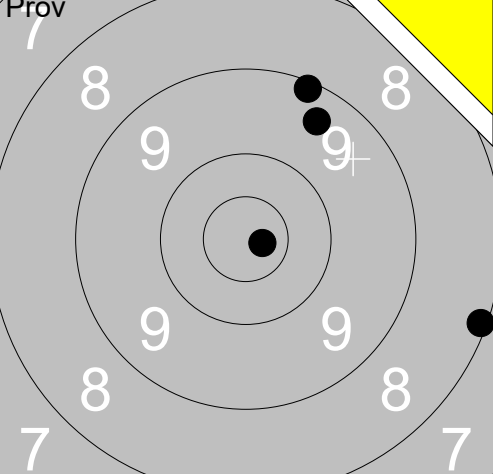
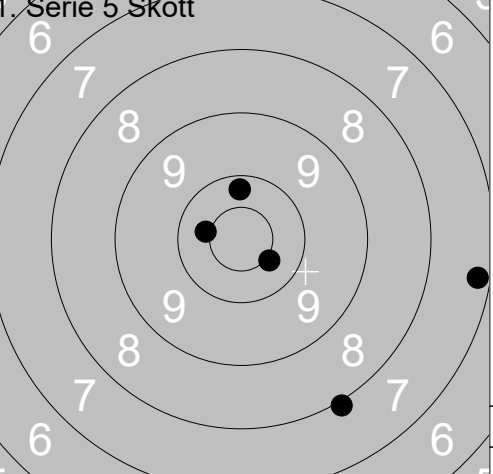
<p>Prov</p> 	<p>1. Serie 5 Skott</p> 	
1: 9.1 ↑ 2: 7.8 ↑ 3: 9.4 ↑ 4: 10.8x → 5: 8.1 ↘	1: 10.2 ↑ 2: 10.4x ← 3: 10.4x ↘ 4: 8.0 ↘ 5: 7.2 →	
Serie 43.0 Total 0.0	Serie 45.0 Total 45.0	

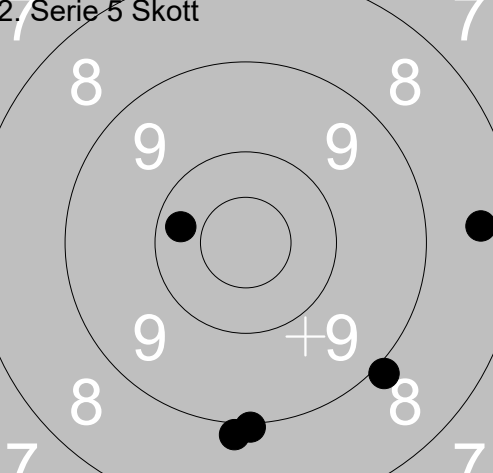
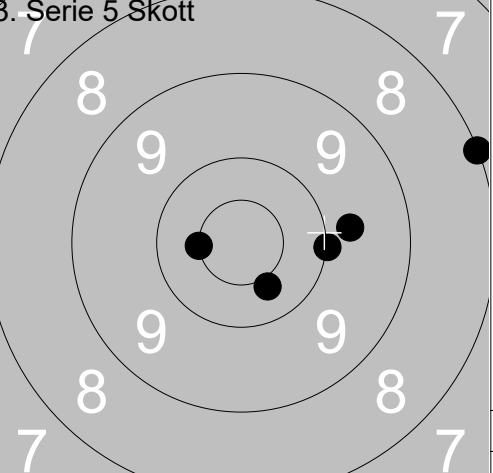
<p>2. Serie 5 Skott</p> 	<p>3. Serie 5 Skott</p> 	
1: 8.4 → 2: 9.0 ↓ 3: 8.9 ↘ 4: 8.9 ↓ 5: 10.3 ←	1: 8.0 → 2: 10.4 ↘ 3: 9.7 → 4: 10.0 → 5: 10.5x ←	
Serie 43.0 Total 88.0	Serie 47.0 Total 135.0	

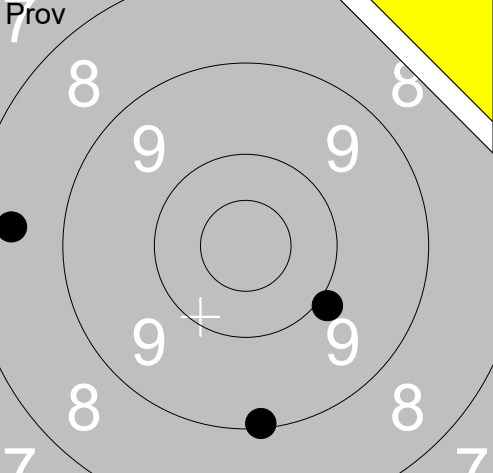
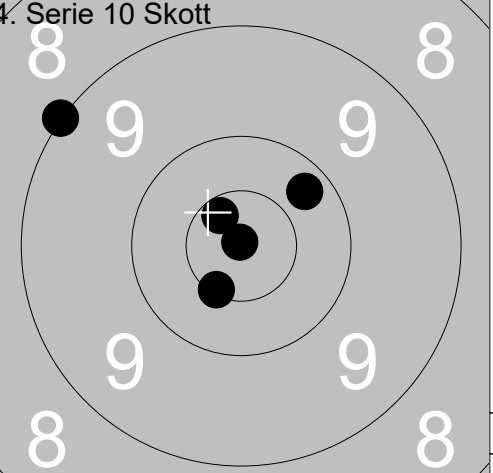
<p>Prov</p> 	<p>4. Serie 10 Skott</p> 	
1: 9.9 ↘ 2: 8.5 ← 3: 9.1 ↓	1: 9.0 ↖ 2: 10.6x ↗ 3: 10.9x ↗ 4: 10.2 ↗ 5: 10.5x ↘	
Serie 26.0 Total 135.0	Serie 49.0 Total 184.0	

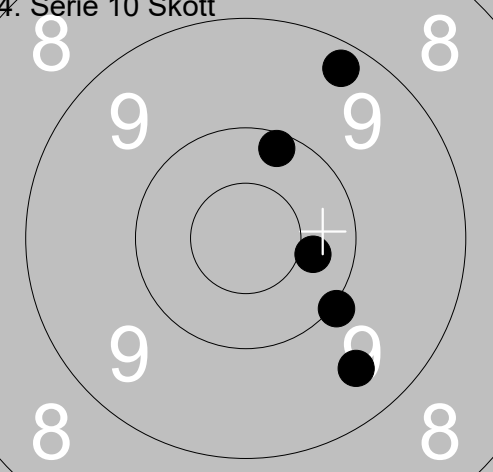
<p>4. Serie 10 Skott</p> 		
6: 10.2 ↑ 7: 9.5 ↘ 8: 9.3 ↑ 9: 10.4 → 10: 10.0 ↘		
Serie 48.0 Total 232.0		

<p>Prov</p>	<p>1: 8.8 ↘ 2: 9.4 ↙ 3: 9.9 ↘ 4: 9.3 ↑ 5: 10.0 →</p>	<p>1. Serie 5 Skott</p>	<p>1: 9.8 ↘ 2: 10.4x ↑ 3: 9.2 ↙ 4: 9.2 ↑ 5: 9.4 ↑</p>
Serie 45.0		Serie 46.0	
Total 0.0		Total 46.0	

<p>2. Serie 5 Skott</p>	<p>1: 10.6x ← 2: 6.9 ← 3: 9.9 → 4: 8.4 ↑ 5: 6.7 →</p>	<p>3. Serie 5 Skott</p>	<p>1: 8.8 ← 2: 10.2 ↘ 3: 10.2 → 4: 8.3 → 5: 4.7 →</p>
Serie 39.0		Serie 40.0	
Total 85.0		Total 125.0	

<p>Prov</p>	<p>1: 10.1 ↑ 2: 9.4 ↘ 3: 9.8 ←</p>	<p>4. Serie 10 Skott</p>	<p>1: 8.7 ↘ 2: 9.8 → 3: 8.5 ↗ 4: 8.9 ↘ 5: 10.4 ↑</p>
Serie 28.0		Serie 43.0	
Total 125.0		Total 168.0	

<p>4. Serie 10 Skott</p>	<p>6: 10.0 ← 7: 9.4 → 8: 9.4 → 9: 10.0 ↘ 10: 7.1 ↓</p>		
Serie 45.0			
Total 213.0			

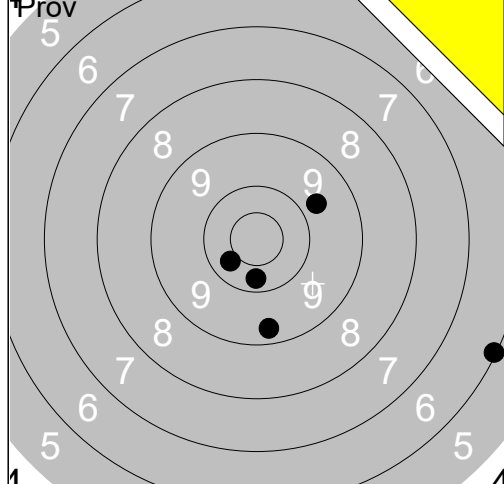

1: 6.1 →
 2: 10.3 ↓
 3: 9.7 ↗
 4: 9.3 ↓
 5: 10.4 ↙

Serie	44.0
Total	0.0

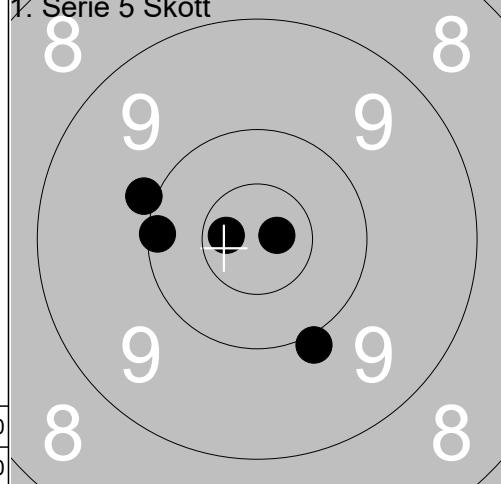

1: 10.7x ←
 2: 10.8x →
 3: 9.9 ↖
 4: 10.1 ←
 5: 9.9 ↘

Serie	48.0
Total	48.0

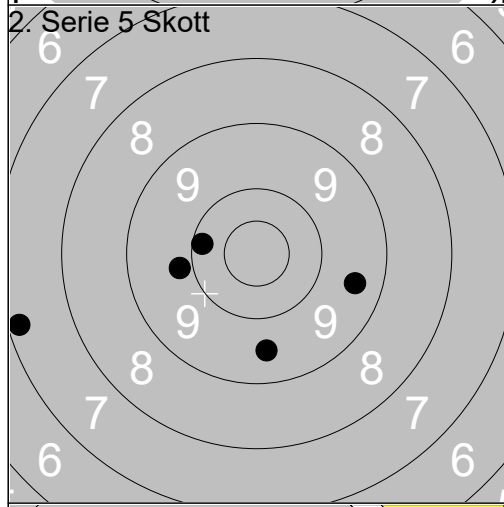

1: 9.5 →
 2: 7.2 ←
 3: 9.8 ←
 4: 9.5 ↓
 5: 10.2 ←

Serie	44.0
Total	92.0

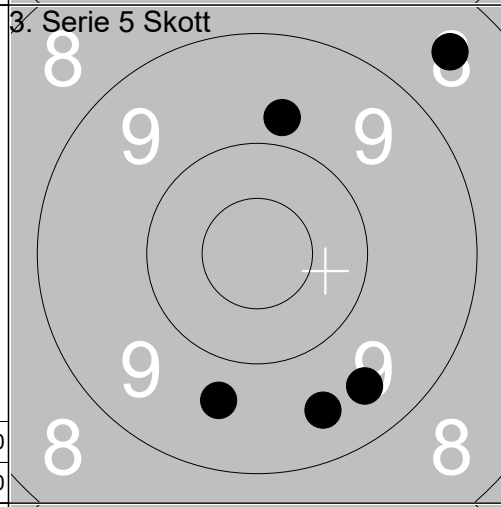

1: 9.8 ↑
 2: 9.7 ↓
 3: 9.5 ↘
 4: 9.5 ↓
 5: 8.5 ↗

Serie	44.0
Total	136.0

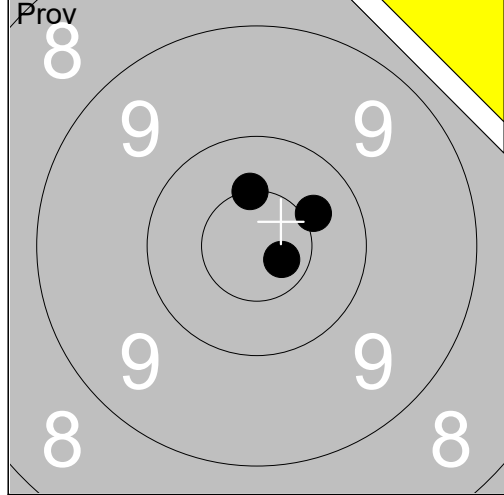

1: 10.5x ↑
 2: 10.4 ↗
 3: 10.7x ↘

Serie	30.0
Total	136.0

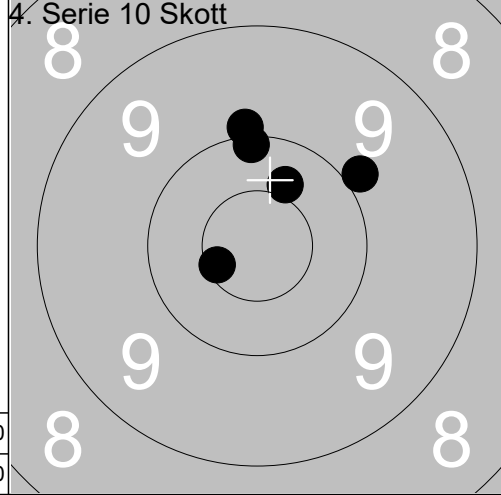

1: 10.6x ←
 2: 9.9 ↗
 3: 10.4 ↗
 4: 10.1 ↑
 5: 9.9 ↑

Serie	48.0
Total	184.0

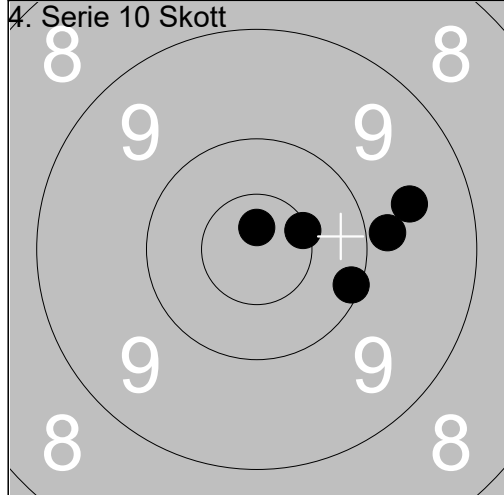

6: 10.8x ↑
 7: 10.1 →
 8: 9.8 →
 9: 9.6 →
 10: 10.5x →

Serie	48.0
Total	232.0

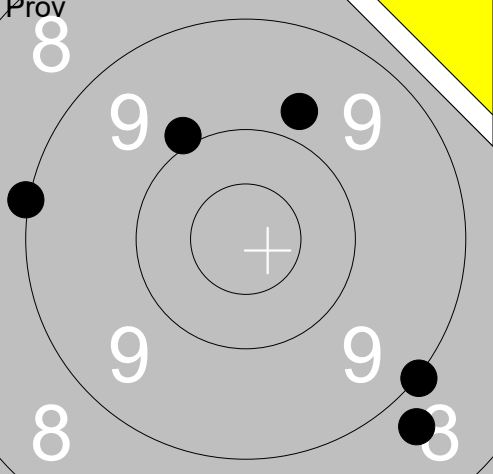
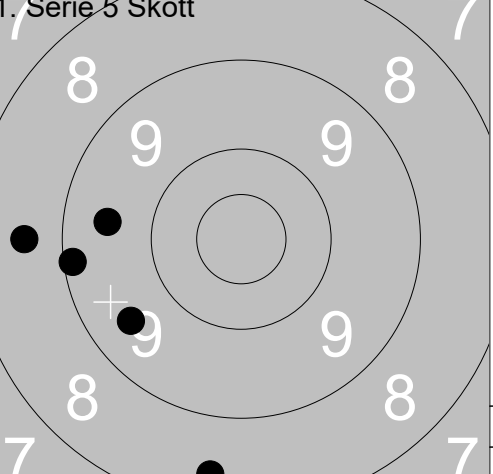
<p>Prov</p> 	<p>1: 8.7 ↘ 2: 9.0 ↘ 3: 9.9 ↗ 4: 9.8 ↗ 5: 9.0 ←</p> <hr/> <p>Serie 44.0 Total 0.0</p>	<p>1. Serie 5 Skott</p> 	<p>1: 8.4 ↓ 2: 9.5 ↙ 3: 9.5 ← 4: 9.1 ← 5: 8.6 ←</p> <hr/> <p>Serie 43.0 Total 43.0</p>
--	---	--	--

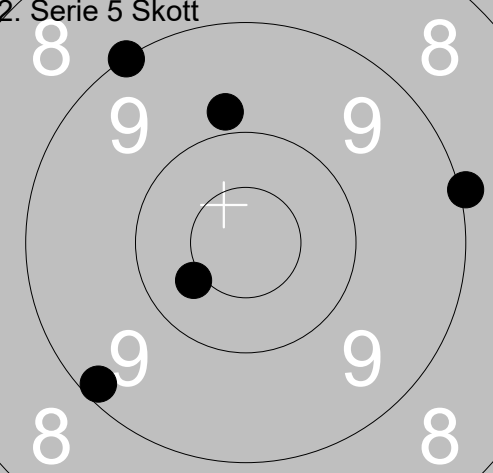
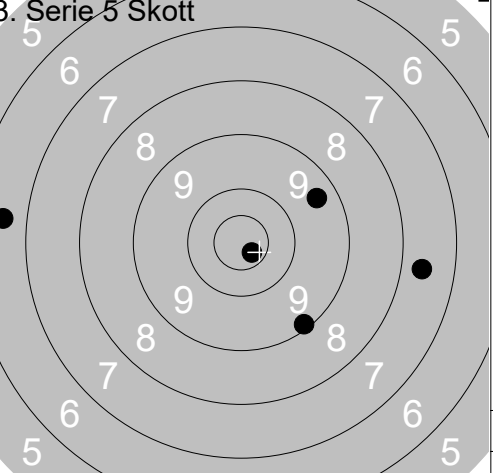
<p>2. Serie 5 Skott</p> 	<p>1: 10.4 ↙ 2: 9.8 ↑ 3: 9.2 ↘ 4: 9.0 → 5: 9.0 ↗</p> <hr/> <p>Serie 46.0 Total 89.0</p>	<p>3. Serie 5 Skott</p> 	<p>1: 9.4 ↗ 2: 7.6 → 3: 10.7x ↘ 4: 6.6 ← 5: 9.1 ↘</p> <hr/> <p>Serie 41.0 Total 130.0</p>
---	---	---	---

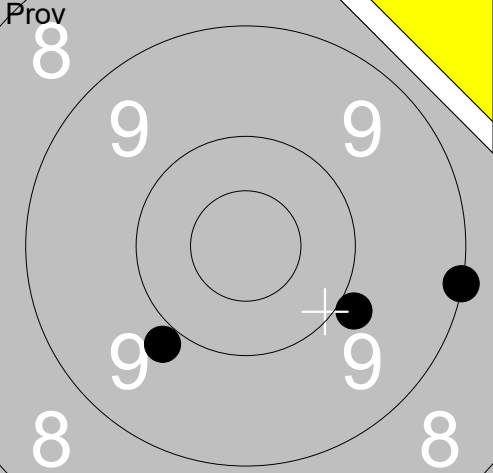
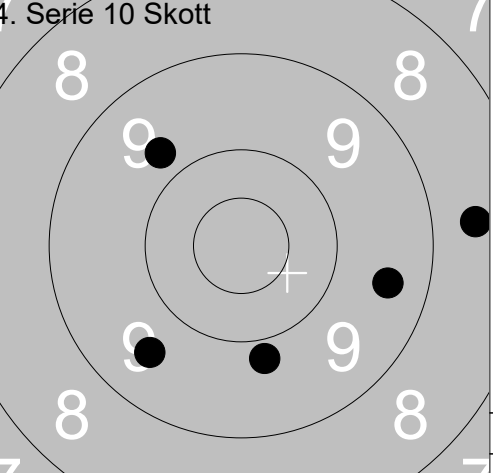
<p>Prov</p> 	<p>1: 9.0 → 2: 9.9 ↘ 3: 9.9 ↘</p> <hr/> <p>Serie 27.0 Total 130.0</p>	<p>4. Serie 10 Skott</p> 	<p>1: 9.6 ↘ 2: 9.5 → 3: 8.6 → 4: 9.8 ↘ 5: 9.7 ↗</p> <hr/> <p>Serie 44.0 Total 174.0</p>
--	---	---	---

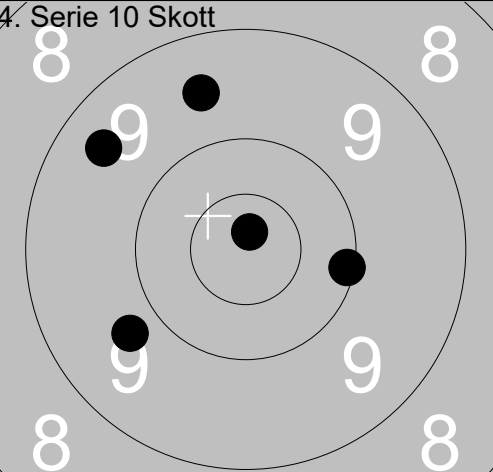
<p>4. Serie 10 Skott</p> 	<p>6: 10.1 → 7: 10.8x ↑ 8: 9.7 ↙ 9: 9.4 ↗ 10: 9.6 ↑</p> <hr/> <p>Serie 47.0 Total 221.0</p>		
---	---	--	--

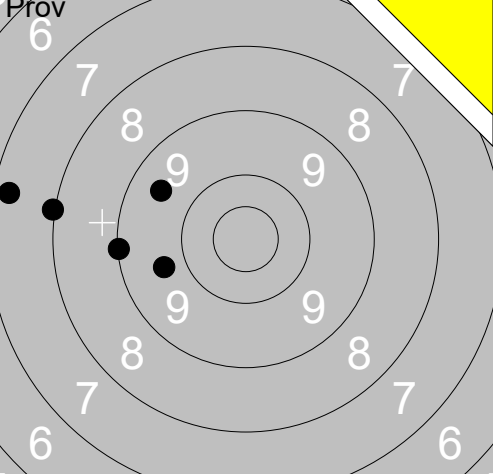
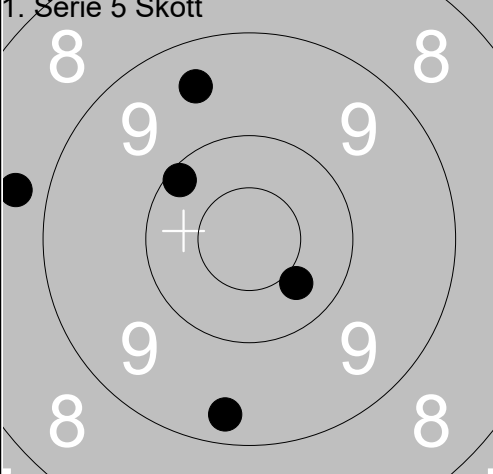
<p>Prov</p> 	<p>1: 7.3 ← 2: 8.0 ← 3: 9.0 ← 4: 9.5 ↗ 5: 9.7 ←</p> <p>Serie 42.0 Total 0.0</p>	<p>1. Serie 5 Skott</p> 	<p>1: 10.4 ↘ 2: 8.7 ← 3: 10.1 ↗ 4: 9.5 ↗ 5: 9.3 ↓</p> <p>Serie 46.0 Total 46.0</p>
--	---	--	--

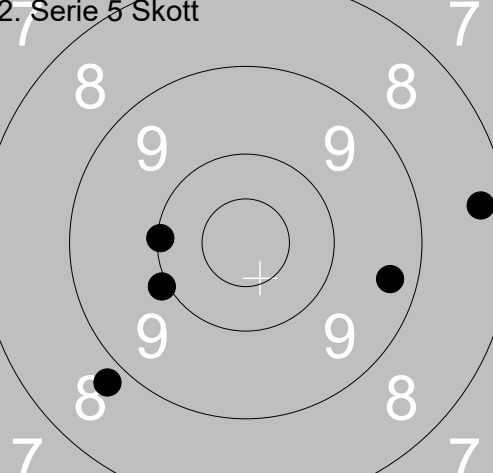
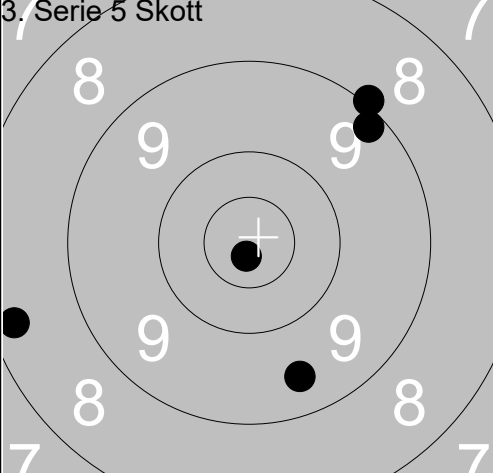
<p>2. Serie 5 Skott</p> 	<p>1: 10.1 ← 2: 10.0 ← 3: 9.3 → 4: 8.8 ↘ 5: 8.3 →</p> <p>Serie 45.0 Total 91.0</p>	<p>3. Serie 5 Skott</p> 	<p>1: 8.3 ← 2: 10.8x ↓ 3: 9.5 ↓ 4: 9.2 ↗ 5: 9.0 ↗</p> <p>Serie 45.0 Total 136.0</p>
---	--	---	---

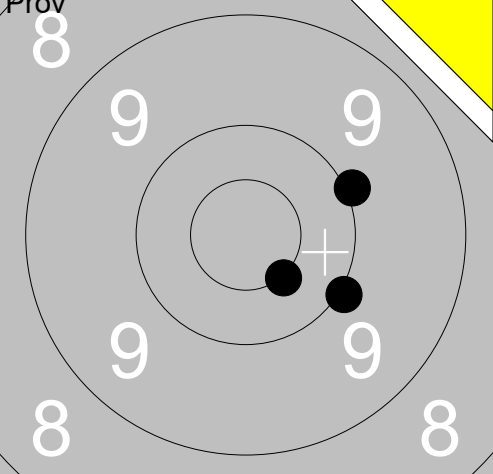
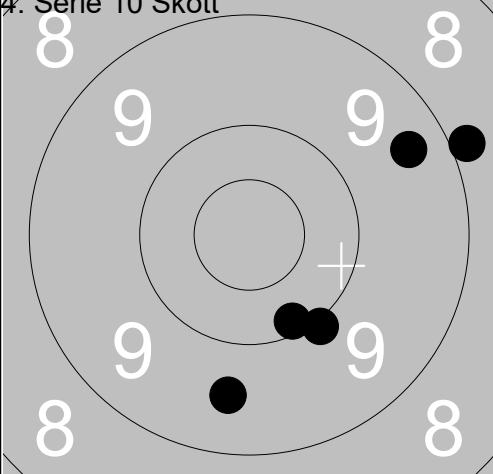
<p>Prov</p> 	<p>1: 10.0 ↘ 2: 10.5x ↓ 3: 10.0 →</p> <p>Serie 30.0 Total 136.0</p>	<p>4. Serie 10 Skott</p> 	<p>1: 10.1 ↓ 2: 8.9 ↗ 3: 9.4 ↗ 4: 10.0 ↓ 5: 9.6 ↓</p> <p>Serie 46.0 Total 182.0</p>
--	---	---	---

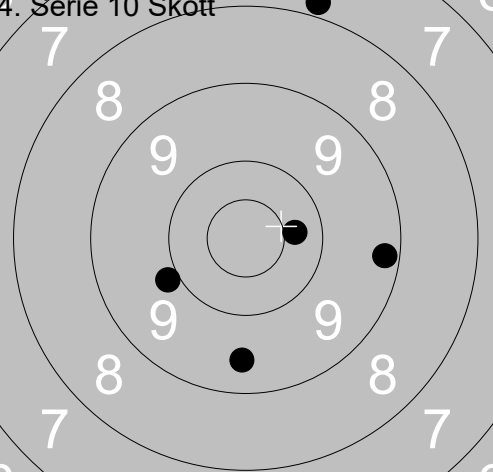
<p>4. Serie 10 Skott</p> 	<p>6: 7.8 ↑ 7: 9.2 → 8: 10.4 → 9: 9.9 ↘ 10: 9.5 ↓</p> <p>Serie 44.0 Total 226.0</p>		
---	---	--	--

<p>Prov</p>	<p>1: 9.6 →</p> <p>2: 9.7 ↘</p> <p>3: 10.2 ↗</p> <p>4: 9.8 ↗</p> <p>5: 10.6x ↗</p>	<p>1. Serie 5 Skott</p>	<p>1: 9.5 ↘</p> <p>2: 9.6 ↘</p> <p>3: 9.8 ↘</p> <p>4: 9.5 ↗</p> <p>5: 10.0 ↑</p>
Serie 47.0		Serie 46.0	
Total 0.0		Total 46.0	

<p>2. Serie 5 Skott</p>	<p>1: 5.3 →</p> <p>2: 9.4 →</p> <p>3: 7.5 ↗</p> <p>4: 8.1 →</p> <p>5: 10.5x ↑</p>	<p>3. Serie 5 Skott</p>	<p>1: 9.6 →</p> <p>2: 9.5 ↘</p> <p>3: 9.3 ←</p> <p>4: 10.2 →</p> <p>5: 9.5 ←</p>
Serie 39.0		Serie 46.0	
Total 85.0		Total 131.0	

<p>Prov</p>	<p>1: 10.1 ↗</p> <p>2: 10.2 ↑</p> <p>3: 9.0 ↘</p>	<p>4. Serie 10 Skott</p>	<p>1: 10.5x ↑</p> <p>2: 8.9 ↘</p> <p>3: 9.6 →</p> <p>4: 9.7 ←</p> <p>5: 8.8 →</p>
Serie 29.0		Serie 44.0	
Total 131.0		Total 175.0	

<p>4. Serie 10 Skott</p>	<p>6: 9.2 ↓</p> <p>7: 9.1 ↙</p> <p>8: 9.9 ↘</p> <p>9: 9.3 ↓</p> <p>10: 8.6 ↘</p>		
Serie 44.0			
Total 219.0			

<p>Prov</p>	<p>1: 10.2 ↗ 2: 9.9 ↓ 3: 10.3 ↗ 4: 9.7 ↘ 5: 9.8 ↙</p>	<p>1. Serie 5 Skott</p>	<p>1: 10.7x ↗ 2: 10.1 ↙ 3: 10.0 ← 4: 10.7x ↘ 5: 10.2 ↗</p>
Serie 47.0		Serie 50.0	
Total 0.0		Total 50.0	

<p>2. Serie 5 Skott</p>	<p>1: 9.7 → 2: 9.2 ← 3: 9.7 ↗ 4: 8.0 ↓ 5: 10.3 →</p>	<p>3. Serie 5 Skott</p>	<p>1: 10.5x → 2: 9.8 ↘ 3: 10.1 ↓ 4: 9.1 → 5: 10.2 ↘</p>
Serie 45.0		Serie 48.0	
Total 95.0		Total 143.0	

<p>Prov</p>	<p>1: 9.6 ↗ 2: 7.1 → 3: 9.4 ↘</p>	<p>4. Serie 10 Skott</p>	<p>1: 10.0 ↗ 2: 10.3 ↘ 3: 10.2 → 4: 10.6x ← 5: 10.2 →</p>
Serie 25.0		Serie 50.0	
Total 143.0		Total 193.0	

<p>4. Serie 10 Skott</p>	<p>6: 10.3 ↗ 7: 9.6 → 8: 10.2 ↓ 9: 10.2 ↗ 10: 9.8 ←</p>		
Serie 48.0			
Total 241.0			

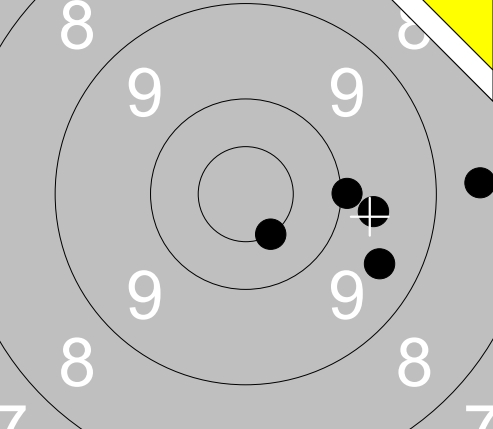
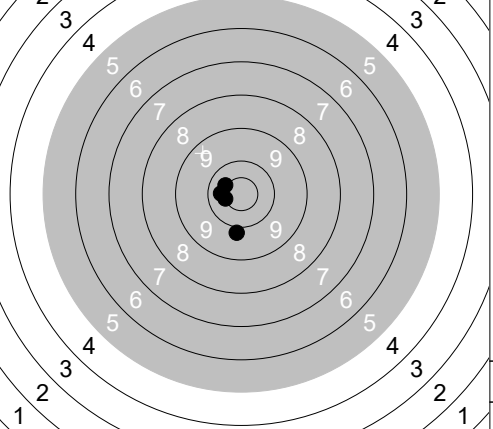
<p>Prov</p> 	<p>1: 10.0 →</p> <p>2: 10.5x ↓</p> <p>3: 9.5 ↓</p> <p>4: 9.7 →</p> <p>5: 8.6 →</p>	<p>1. Serie 5 Skott</p> 	<p>1: 10.4x ↖</p> <p>2: 2.7 ↗</p> <p>3: 10.4 ←</p> <p>4: 10.5x ←</p> <p>5: 9.8 ↓</p>
Serie 46.0		Serie 41.0	
Total 0.0		Total 41.0	

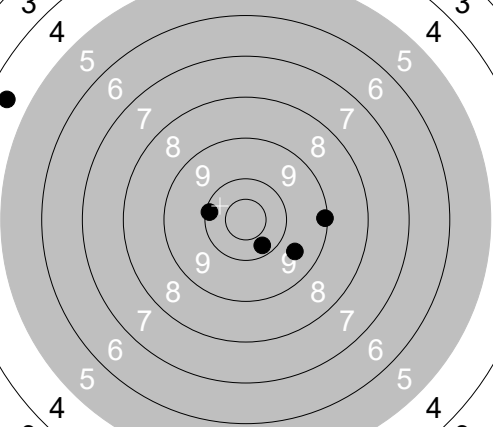
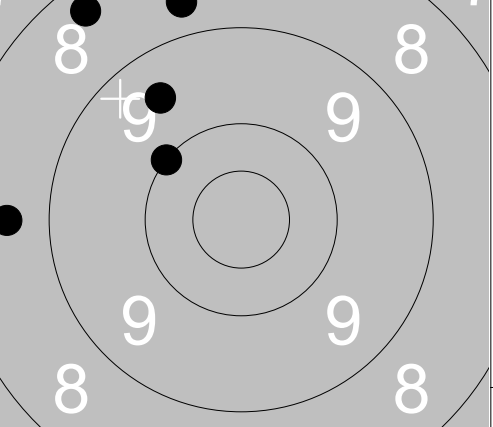
<p>2. Serie 5 Skott</p> 	<p>1: 10.2 ↓</p> <p>2: 10.1 ←</p> <p>3: 4.5 ↗</p> <p>4: 9.6 ↓</p> <p>5: 9.1 →</p>	<p>3. Serie 5 Skott</p> 	<p>1: 10.0 ↖</p> <p>2: 8.7 ↗</p> <p>3: 9.5 ↗</p> <p>4: 8.3 ↗</p> <p>5: 8.6 ←</p>
Serie 42.0		Serie 43.0	
Total 83.0		Total 126.0	

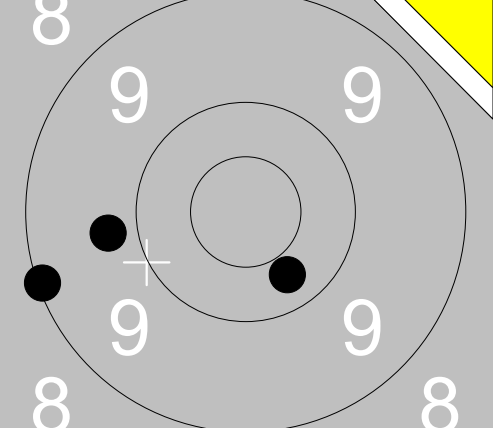
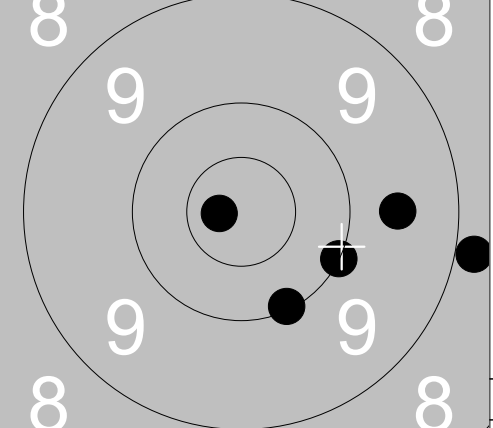
<p>Prov</p> 	<p>1: 9.8 ←</p> <p>2: 10.3 ↓</p> <p>3: 9.1 ←</p>	<p>4. Serie 10 Skott</p> 	<p>1: 10.8x ←</p> <p>2: 9.6 →</p> <p>3: 10.1 ↓</p> <p>4: 10.0 ↓</p> <p>5: 8.9 →</p>
Serie 28.0		Serie 47.0	
Total 126.0		Total 173.0	

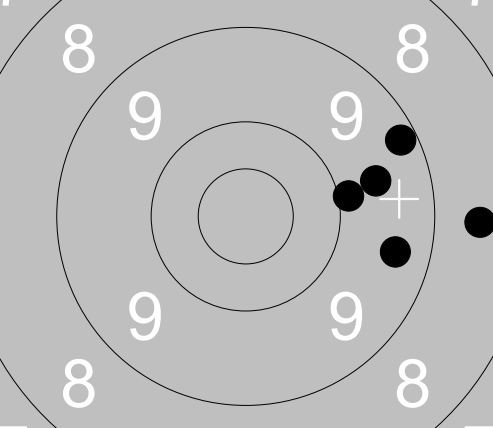
<p>4. Serie 10 Skott</p> 	<p>6: 9.2 →</p> <p>7: 9.4 →</p> <p>8: 9.9 →</p> <p>9: 9.6 →</p> <p>10: 8.5 →</p>		
Serie 44.0			
Total 217.0			

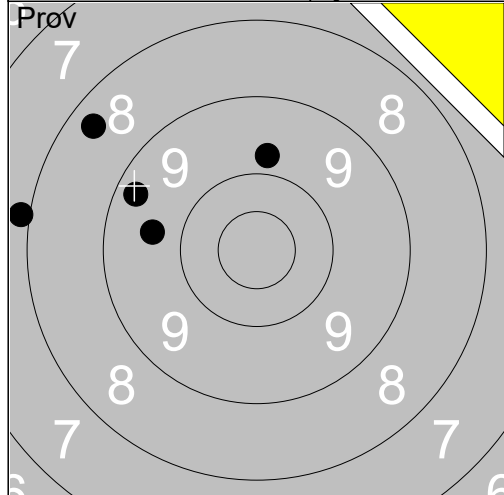

1:	7.9	←
2:	9.3	↖
3:	8.4	↗
4:	9.6	←
5:	9.8	↑

Serie	42.0
Total	0.0

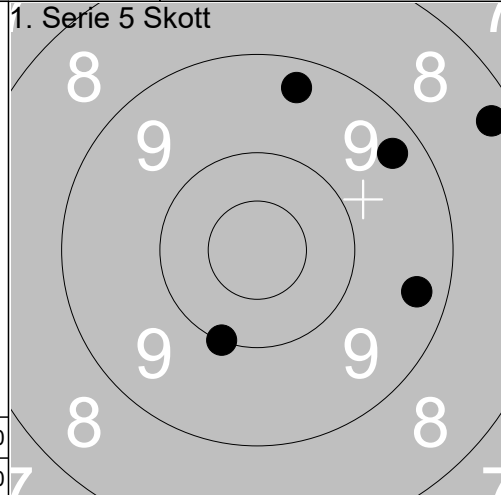

1:	10.0	↓
2:	8.3	↗
3:	9.3	→
4:	9.3	↗
5:	9.3	↑

Serie	45.0
Total	45.0

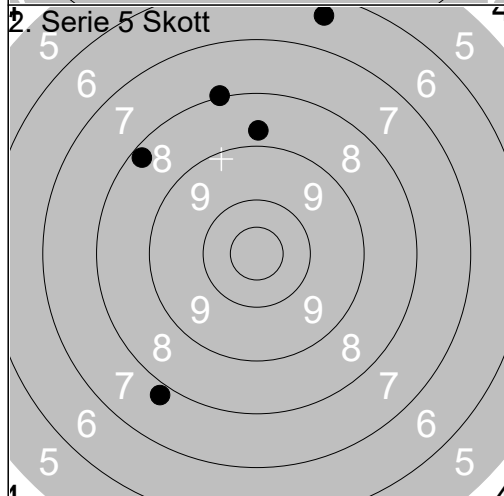

1:	7.8	↙
2:	6.4	↑
3:	8.2	↖
4:	8.0	↑
5:	8.7	↑

Serie	37.0
Total	82.0

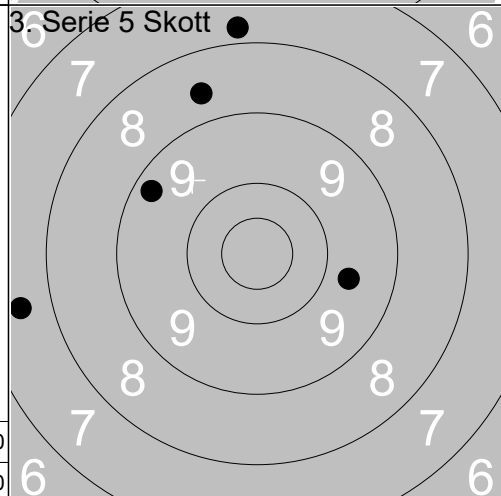

1:	7.6	←
2:	9.3	↖
3:	8.6	↑
4:	7.8	↑
5:	9.7	→

Serie	40.0
Total	122.0

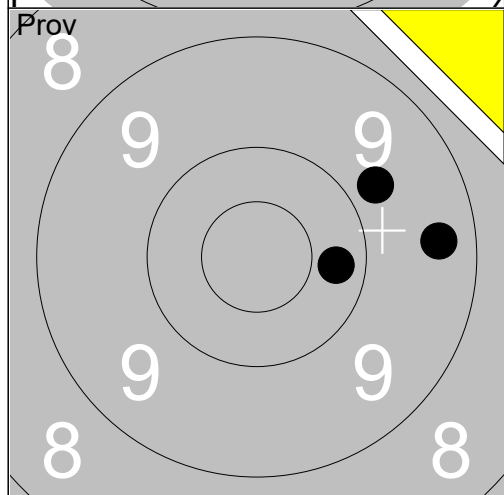

1:	9.8	↗
2:	9.4	→
3:	10.3	→

Serie	28.0
Total	122.0

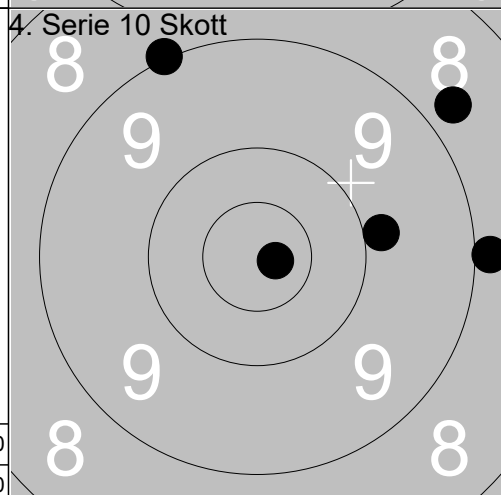

1:	9.0	↖
2:	8.8	↗
3:	9.9	→
4:	8.9	→
5:	10.8x	→

Serie	44.0
Total	166.0

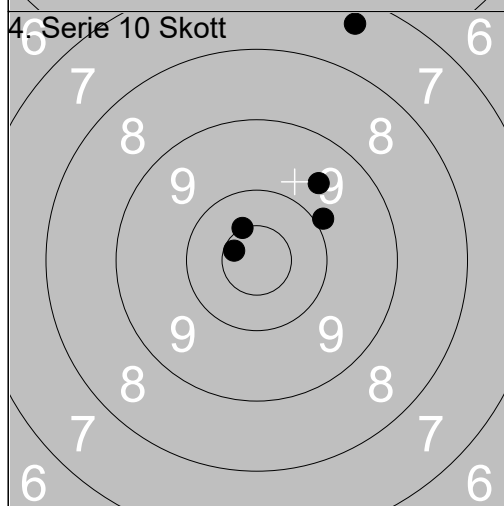

6:	7.4	↑
7:	9.9	↗
8:	10.5x	↖
9:	10.6x	↖
10:	9.6	↗

Serie	45.0
Total	211.0

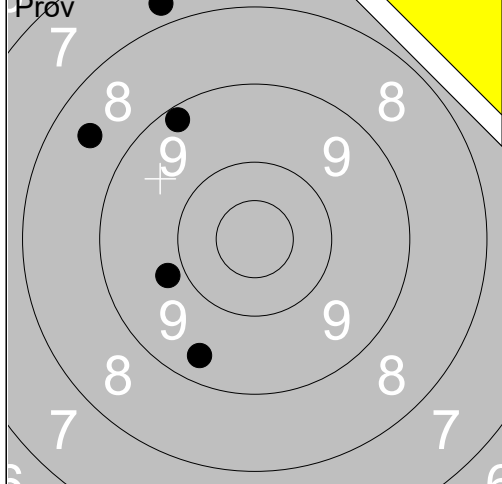

1:	9.4	↘
2:	9.8	←
3:	9.2	↗
4:	8.5	↗
5:	7.7	↗

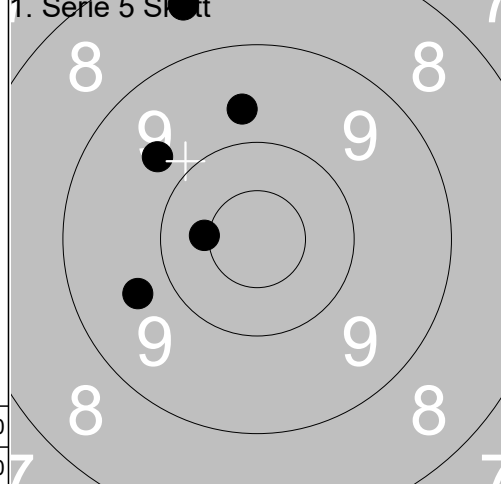

1:	8.5	↑
2:	9.7	↑
3:	9.7	←
4:	9.7	↖
5:	10.4x	←

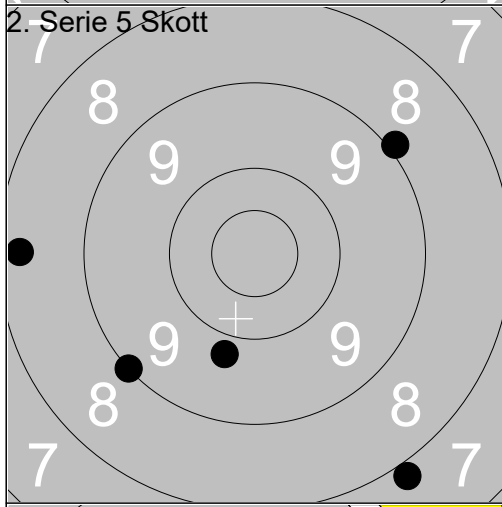

1:	7.9	↘
2:	8.3	←
3:	9.0	↙
4:	8.9	↗
5:	9.8	↓

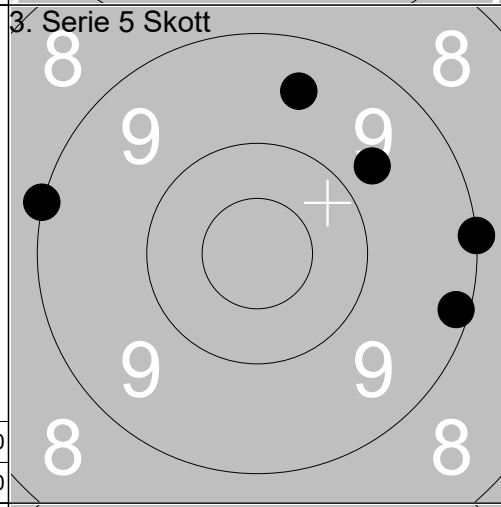

1:	9.2	→
2:	9.7	↗
3:	9.5	↑
4:	9.0	→
5:	9.0	←

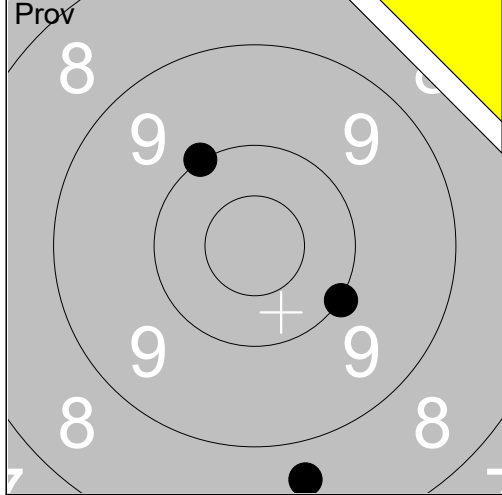

1:	8.6	↘
2:	10.0	↘
3:	10.0	↗

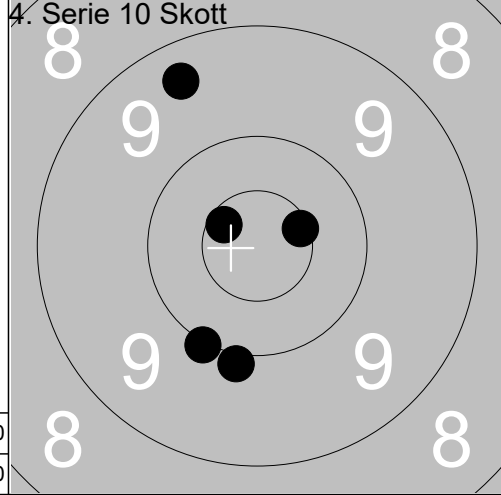

1:	9.4	↖
2:	10.6x	↖
3:	10.0	↘
4:	10.6x	↗
5:	9.9	↓

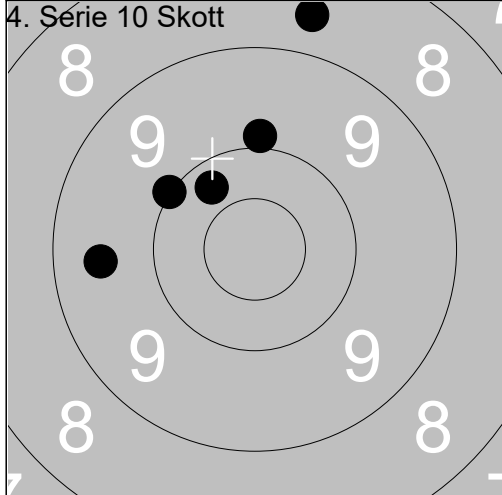

6:	9.5	←
7:	10.3	↗
8:	9.9	↑
9:	10.0	↗
10:	8.6	↑

Serie	48.0
Total	179.0

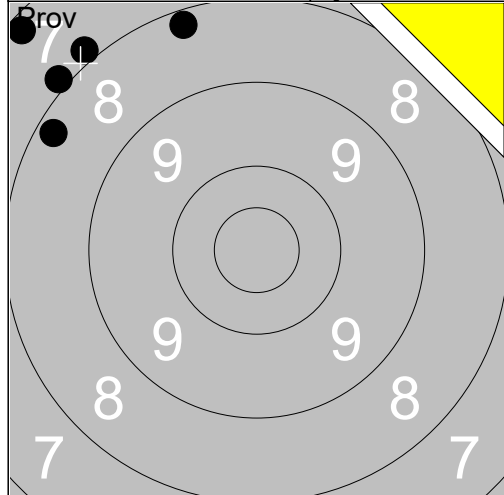

1:	7.9	↗
2:	8.2	↗
3:	7.2	↗
4:	8.2	↗
5:	7.9	↗
Serie		37.0
Total		0.0

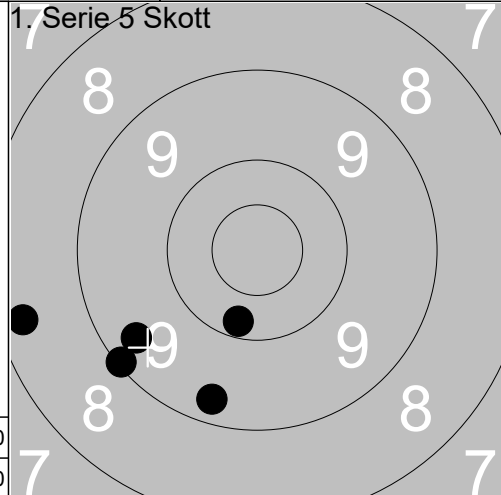

1:	10.2	↓
2:	8.3	←
3:	9.4	↙
4:	9.1	↙
5:	9.3	↓
Serie		45.0
Total		45.0

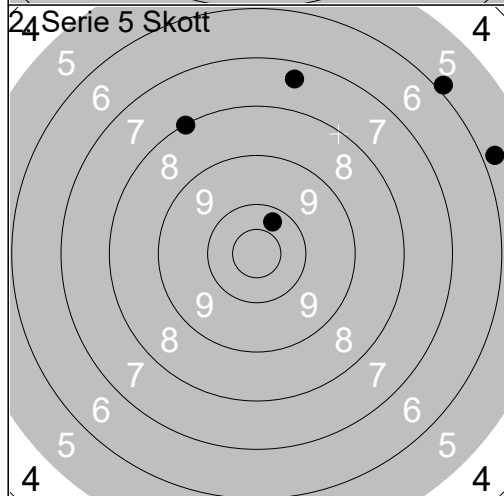

1:	5.8	→
2:	8.0	↖
3:	10.3	↗
4:	5.9	↗
5:	7.4	↑
Serie		35.0
Total		80.0

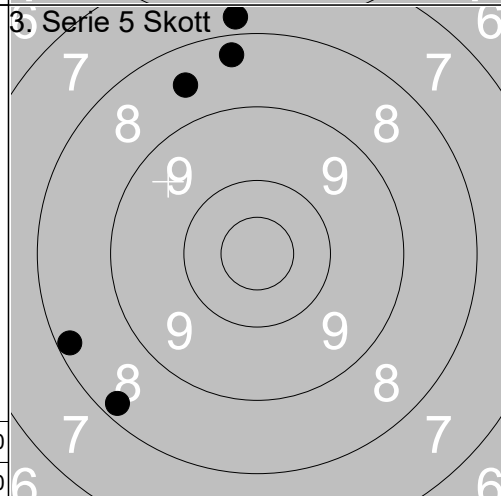

1:	8.2	←
2:	8.2	↙
3:	8.3	↑
4:	7.8	↑
5:	8.5	↖
Serie		39.0
Total		119.0

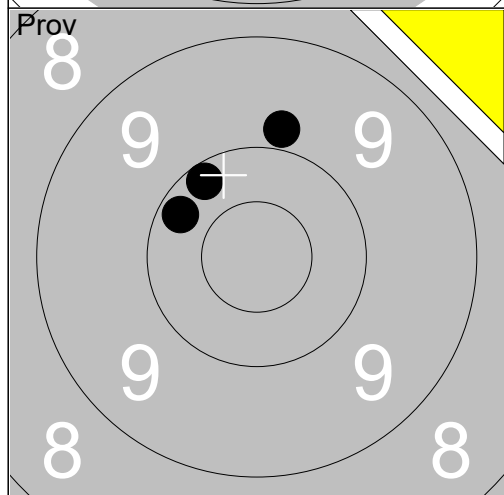

1:	10.2	↖
2:	9.8	↑
3:	10.2	↖
Serie		29.0
Total		119.0

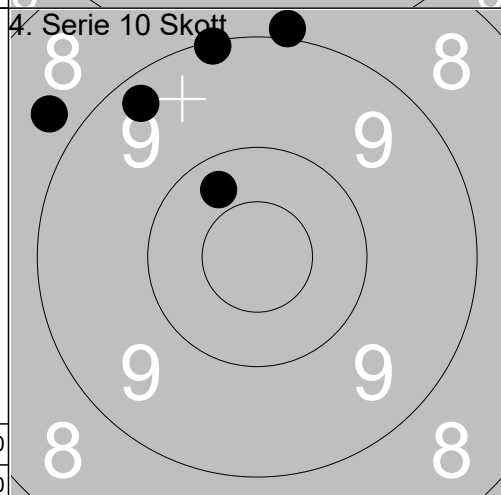

1:	10.3	↖
2:	8.9	↑
3:	9.1	↑
4:	8.7	↖
5:	9.3	↖
Serie		44.0
Total		163.0

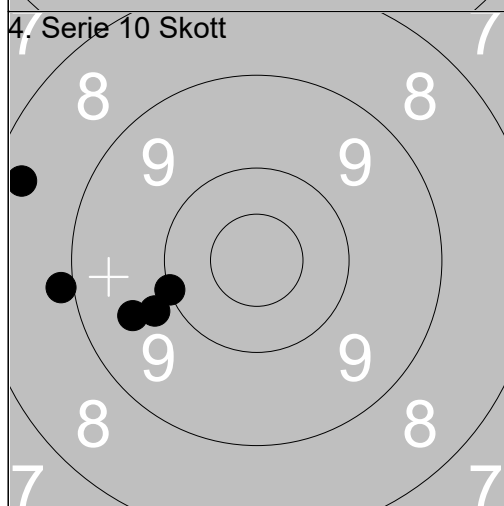

6:	8.4	←
7:	8.9	←
8:	9.8	←
9:	9.6	←
10:	10.0	←
Serie		44.0
Total		207.0

<p>Prov</p>	<p>1: 10.5x ↓</p> <p>2: 8.9 →</p> <p>3: 10.2 →</p> <p>4: 9.2 ↑</p> <p>5: 9.4 ↓</p>	<p>1. Serie 5 Skott</p>		<p>1: 10.1 →</p> <p>2: 9.9 →</p> <p>3: 10.0 ←</p> <p>4: 10.5x ←</p> <p>5: 10.3 ↑</p>
Serie 46.0				Serie 49.0
Total 0.0				Total 49.0

<p>2. Serie 5 Skott</p>	<p>1: 6.4 ↑</p> <p>2: 8.3 ↑</p> <p>3: 10.3 ↗</p> <p>4: 9.9 ←</p> <p>5: 8.9 ←</p>	<p>3. Serie 5 Skott</p>		<p>1: 7.8 ↑</p> <p>2: 7.3 ←</p> <p>3: 10.3 ↖</p> <p>4: 10.1 ↓</p> <p>5: 8.1 ↙</p>
Serie 41.0				Serie 42.0
Total 90.0				Total 132.0

<p>Prov</p>	<p>1: 9.6 ↓</p> <p>2: 10.5x →</p> <p>3: 10.3 ←</p>	<p>4. Serie 10 Skott</p>		<p>1: 10.7x ↑</p> <p>2: 8.6 ↑</p> <p>3: 10.1 →</p> <p>4: 10.1 ↓</p> <p>5: 9.1 ↗</p>
Serie 29.0				Serie 47.0
Total 132.0				Total 179.0

<p>4. Serie 10 Skott</p>	<p>6: 9.8 ↗</p> <p>7: 9.8 →</p> <p>8: 10.4 ↓</p> <p>9: 9.4 ↗</p> <p>10: 10.3 ↓</p>			
Serie 47.0				
Total 226.0				

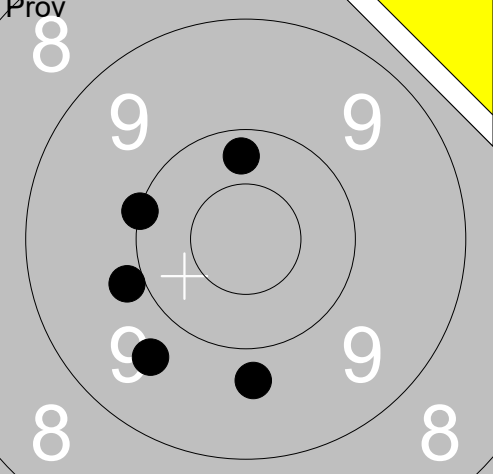
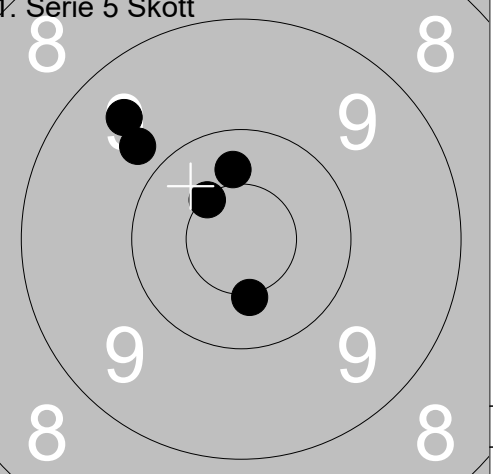
<p>Prov</p> 	<p>1: 9.9 ←</p> <p>2: 9.7 ↙</p> <p>3: 9.7 ↓</p> <p>4: 10.0 ←</p> <p>5: 10.3 ↑</p>	<p>1. Serie 5 Skott</p> 	<p>1: 9.8 ↖</p> <p>2: 9.5 ↗</p> <p>3: 10.5x ↗</p> <p>4: 10.5x ↓</p> <p>5: 10.4 ↑</p>
Serie 47.0		Serie 48.0	
Total 0.0		Total 48.0	

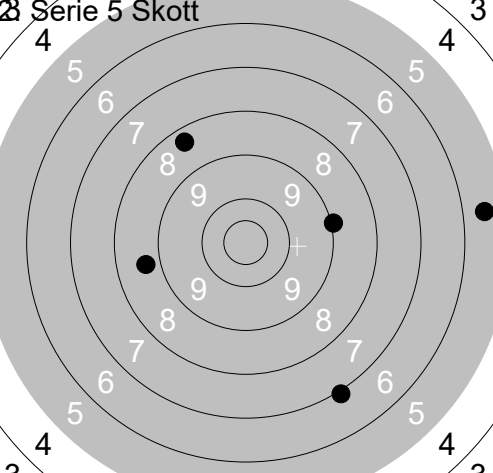
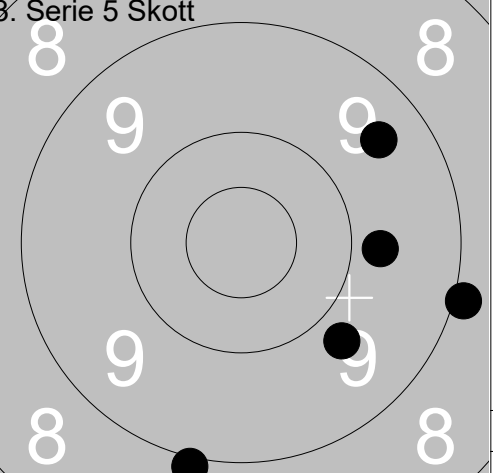
<p>2. Serie 5 Skott</p> 	<p>1: 8.7 ←</p> <p>2: 7.0 ↘</p> <p>3: 8.3 ↗</p> <p>4: 5.5 →</p> <p>5: 9.0 →</p>	<p>3. Serie 5 Skott</p> 	<p>1: 9.8 ↘</p> <p>2: 8.9 →</p> <p>3: 8.9 ↓</p> <p>4: 9.5 ↗</p> <p>5: 9.8 →</p>
Serie 37.0		Serie 43.0	
Total 85.0		Total 128.0	

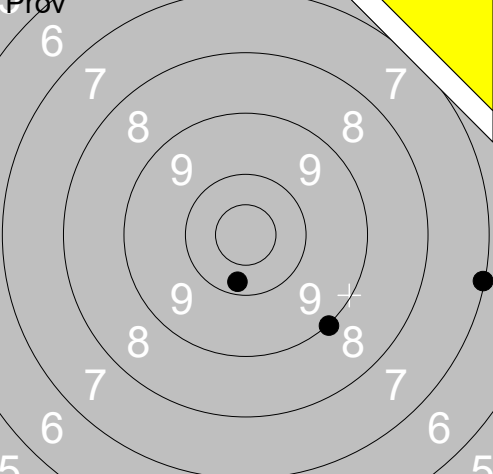
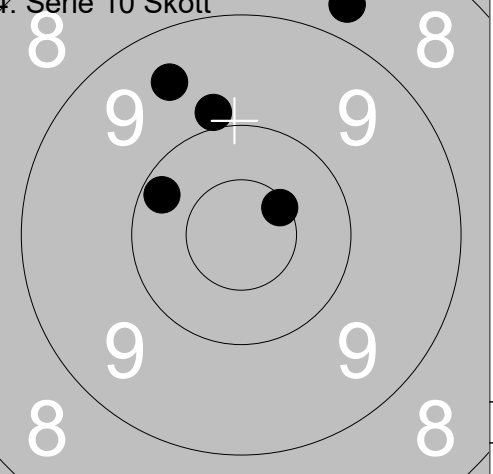
<p>Prov</p> 	<p>1: 7.1 →</p> <p>2: 9.0 ↘</p> <p>3: 10.2 ↓</p>	<p>4. Serie 10 Skott</p> 	<p>1: 8.7 ↗</p> <p>2: 10.6x ↗</p> <p>3: 9.5 ↗</p> <p>4: 9.9 ↑</p> <p>5: 10.2 ↖</p>
Serie 26.0		Serie 46.0	
Total 128.0		Total 174.0	

<p>4. Serie 10 Skott</p> 	<p>6: 8.0 ↓</p> <p>7: 9.3 ←</p> <p>8: 9.0 ↙</p> <p>9: 8.5 ↓</p> <p>10: 9.2 ↙</p>		
Serie 43.0			
Total 217.0			

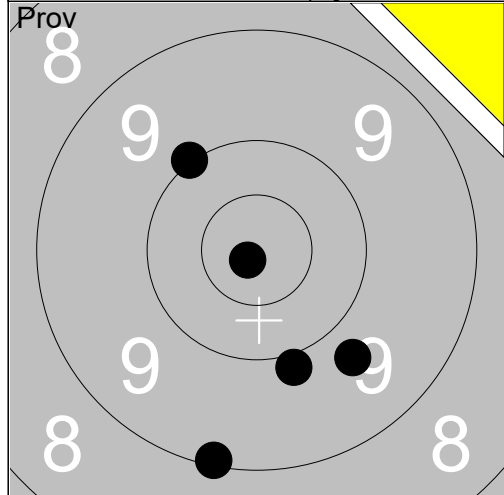

1:	9.9	↓
2:	9.1	↓
3:	10.0	↗
4:	9.7	↓
5:	10.8x	↓
Serie		47.0
Total		0.0

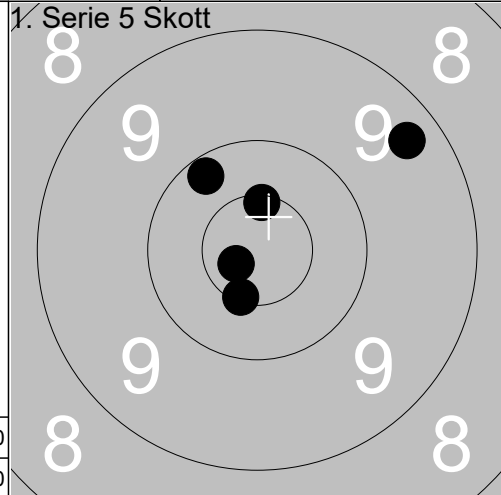

1:	10.5x	↑
2:	10.5x	↓
3:	9.3	↗
4:	10.2	↗
5:	10.7x	↙
Serie		49.0
Total		49.0

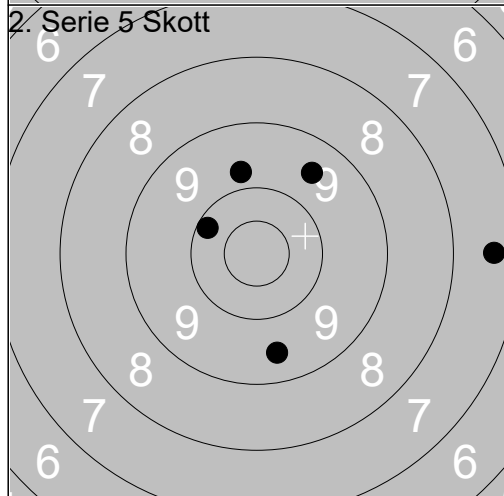

1:	9.8	↑
2:	7.4	→
3:	10.2	↖
4:	9.5	↓
5:	9.5	↗
Serie		44.0
Total		93.0

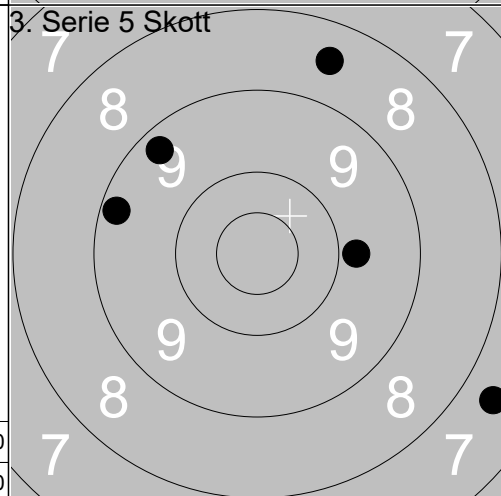

1:	9.8	→
2:	8.5	↑
3:	9.2	↖
4:	7.6	↓
5:	9.3	↗
Serie		42.0
Total		135.0

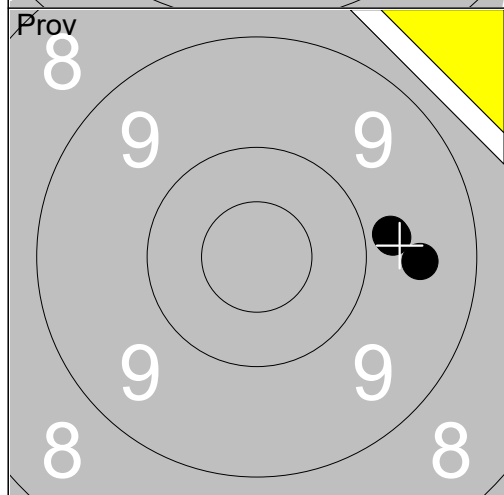

1:	9.8	→
2:	9.5	→
3:	9.8	→
Serie		27.0
Total		135.0

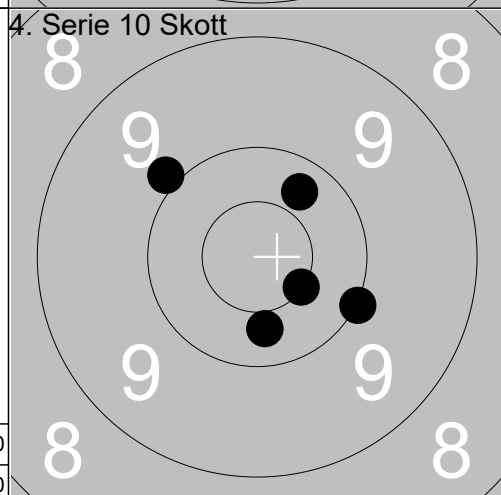

1:	9.9	↖
2:	10.3	↓
3:	10.5x	↘
4:	10.0	↘
5:	10.3	↗
Serie		49.0
Total		184.0

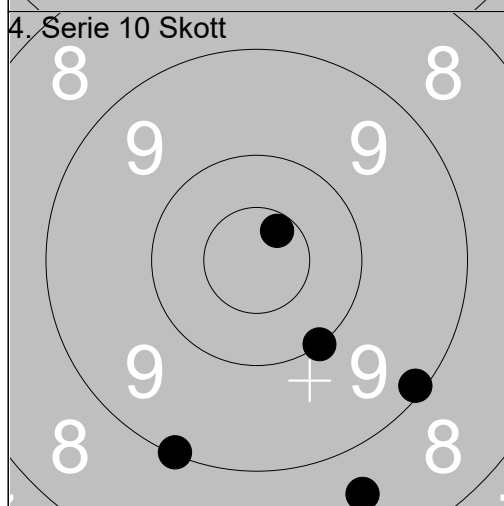

6:	10.6x	↗
7:	8.6	↓
8:	9.1	↓
9:	10.0	↓
10:	9.1	↓
Serie		46.0
Total		230.0

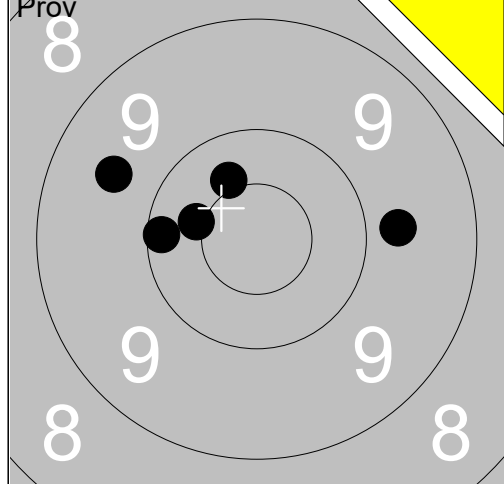

1:	10.4x	←
2:	10.1	←
3:	9.6	↗
4:	9.7	→
5:	10.4	↗
Serie		48.0
Total		0.0

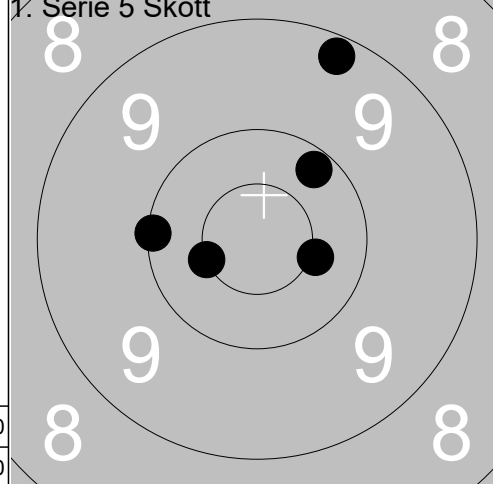

1:	9.2	↗
2:	10.1	←
3:	10.5x	←
4:	10.2	↗
5:	10.4x	→
Serie		49.0
Total		49.0

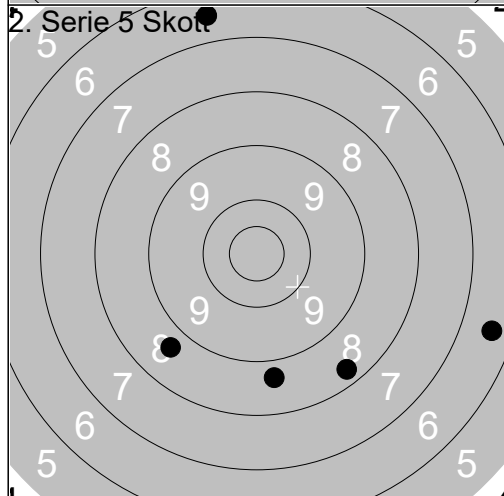

1:	8.3	↘
2:	6.5	↑
3:	8.7	↘
4:	6.4	→
5:	8.7	↘
Serie		36.0
Total		85.0

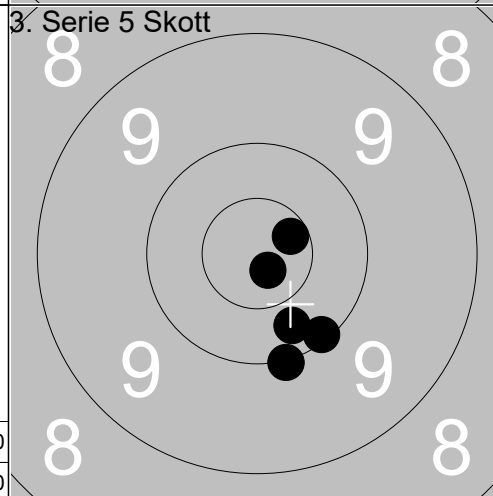

1:	10.1	↘
2:	10.6x	↗
3:	10.0	↘
4:	10.8x	↘
5:	10.3	↘
Serie		50.0
Total		135.0

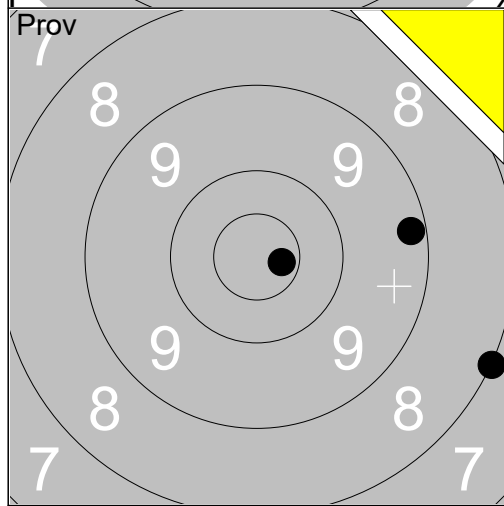

1:	9.2	→
2:	8.0	↘
3:	10.7x	→
Serie		27.0
Total		135.0

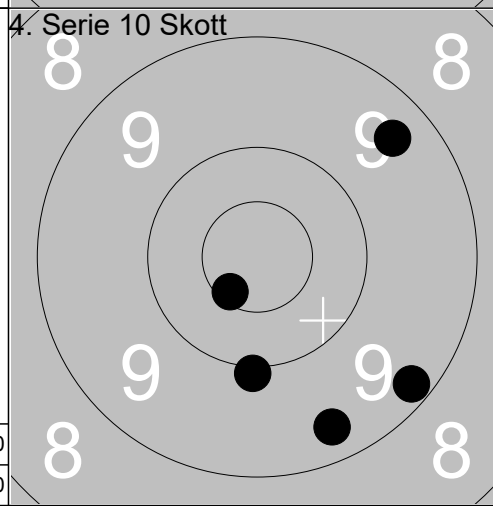

1:	9.2	↘
2:	10.0	↘
3:	10.6x	↘
4:	9.3	↘
5:	9.4	↗
Serie		47.0
Total		182.0

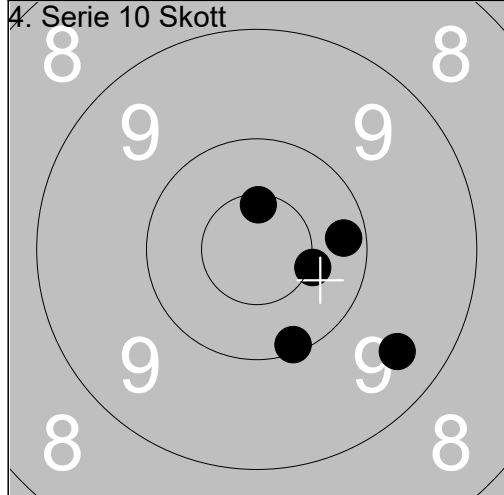

6:	9.5	↘
7:	10.2	→
8:	10.6x	↑
9:	10.5x	↘
10:	10.1	↘
Serie		49.0
Total		231.0

<p>Prov</p>	<p>1. Serie 5 Skott</p>	
1: 10.2 ↘ 2: 9.8 ↓ 3: 10.5x ↓ 4: 10.4 ↘ 5: 10.2 ↗	1: 9.2 → 2: 9.6 ↑ 3: 10.5x ↖ 4: 9.8 → 5: 10.5x ←	
Serie 49.0	Serie 47.0	
Total 0.0	Total 47.0	

<p>2. Serie 5 Skott</p>	<p>3. Serie 5 Skott</p>	
1: 9.2 ← 2: 8.6 → 3: 10.7x ↓ 4: 9.5 ↗ 5: 8.5 ↗	1: 9.5 ↖ 2: 9.6 ← 3: 9.2 ↙ 4: 10.0 → 5: 10.3 ↓	
Serie 44.0	Serie 47.0	
Total 91.0	Total 138.0	

<p>Prov</p>	<p>4. Serie 10 Skott</p>	
1: 9.0 → 2: 9.1 ↓ 3: 8.3 ↓	1: 9.1 ↑ 2: 10.7x ↓ 3: 9.4 ← 4: 10.4x ↓ 5: 9.9 ←	
Serie 26.0	Serie 47.0	
Total 138.0	Total 185.0	

<p>4. Serie 10 Skott</p>		
6: 10.1 ↓ 7: 9.8 ↗ 8: 10.3 ↓ 9: 9.2 ↓ 10: 8.5 ↓		
Serie 46.0		
Total 231.0		

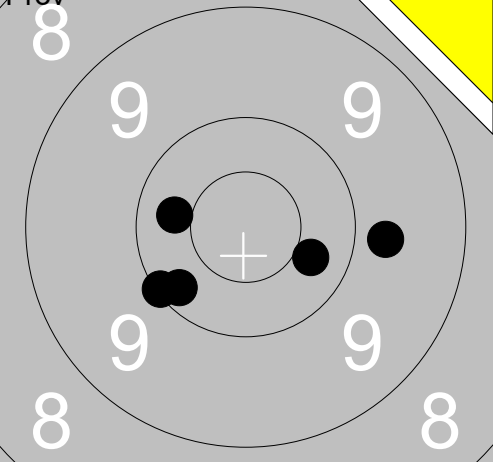
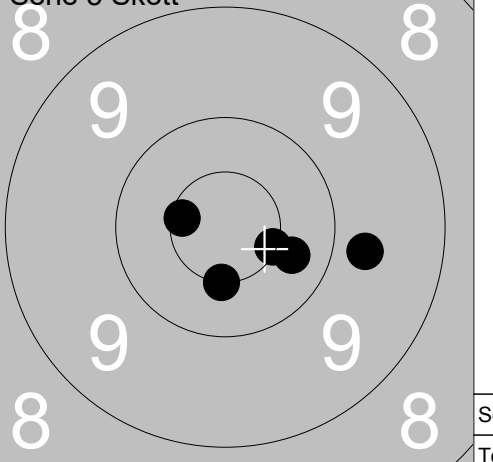
<p>Prov</p> 	<p>1: 10.3 →</p> <p>2: 9.8 →</p> <p>3: 10.3 ←</p> <p>4: 10.2 ↙</p> <p>5: 10.1 ↙</p>	<p>1. Serie 5 Skott</p> 	<p>1: 10.5x →</p> <p>2: 10.3 →</p> <p>3: 9.7 →</p> <p>4: 10.6x ←</p> <p>5: 10.5x ↓</p>
Serie 49.0	Total 0.0	Serie 49.0	Total 49.0

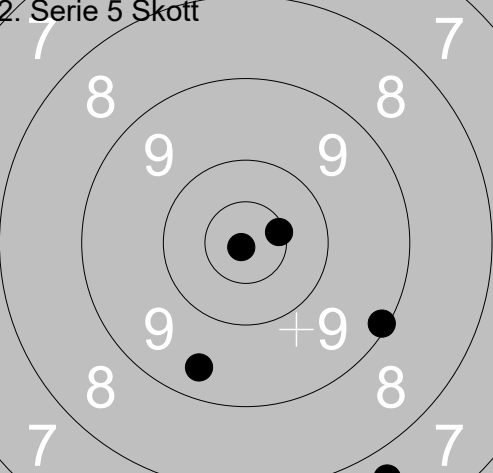
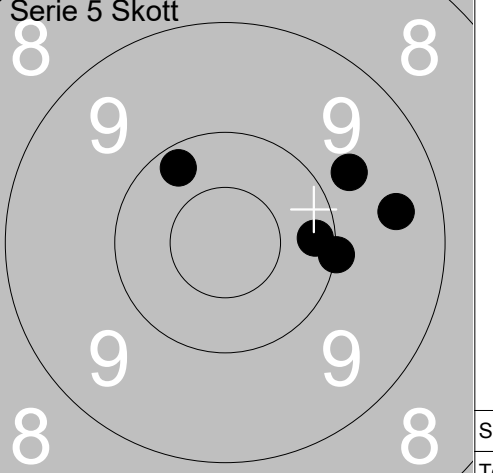
<p>2. Serie 5 Skott</p> 	<p>1: 10.6x →</p> <p>2: 9.4 ↓</p> <p>3: 7.7 ↓</p> <p>4: 10.9x ↙</p> <p>5: 9.1 →</p>	<p>3. Serie 5 Skott</p> 	<p>1: 9.5 →</p> <p>2: 9.7 ↗</p> <p>3: 10.0 →</p> <p>4: 10.2 →</p> <p>5: 10.2 ↗</p>
Serie 45.0	Total 94.0	Serie 48.0	Total 142.0

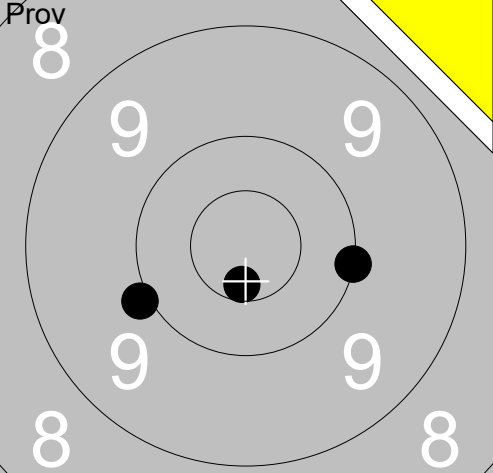
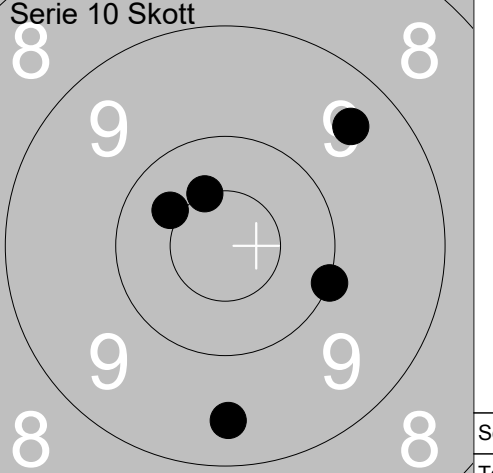
<p>Prov</p> 	<p>1: 9.9 ←</p> <p>2: 10.6x ↓</p> <p>3: 10.0 →</p>	<p>4. Serie 10 Skott</p> 	<p>1: 9.5 ↗</p> <p>2: 10.0 →</p> <p>3: 10.5x ↗</p> <p>4: 9.4 ↓</p> <p>5: 10.4 ↗</p>
Serie 29.0	Total 142.0	Serie 48.0	Total 190.0

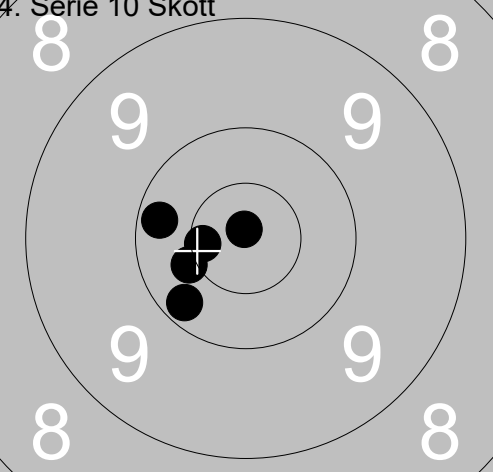
<p>4. Serie 10 Skott</p> 	<p>6: 10.6x ←</p> <p>7: 10.4x ←</p> <p>8: 10.9x ↑</p> <p>9: 10.2 ↙</p> <p>10: 10.2 ←</p>		
Serie 50.0	Total 240.0		

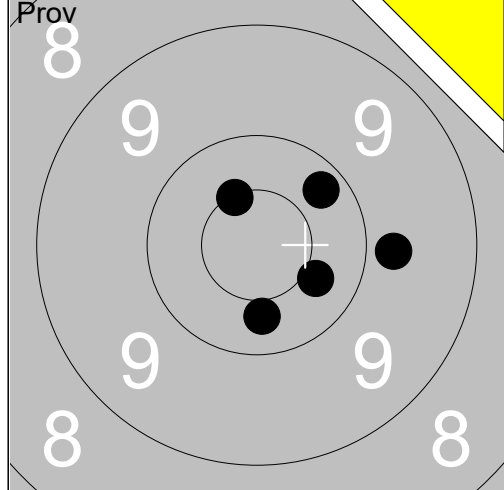

1:	10.2	↗
2:	10.5x	↗
3:	10.3	↓
4:	10.4	↘
5:	9.8	→
Serie		49.0
Total		0.0

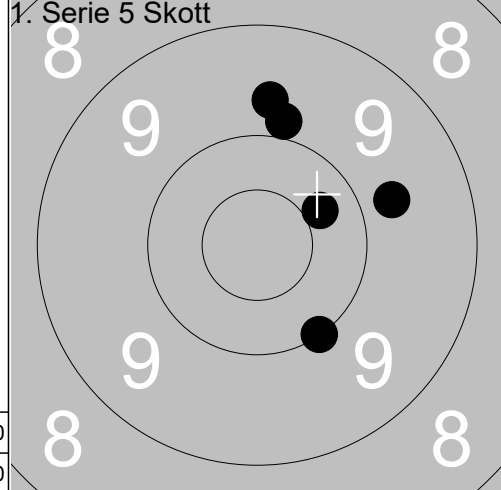

1:	10.0	↘
2:	9.9	↑
3:	10.3	↗
4:	9.7	↑
5:	9.7	↗
Serie		47.0
Total		47.0

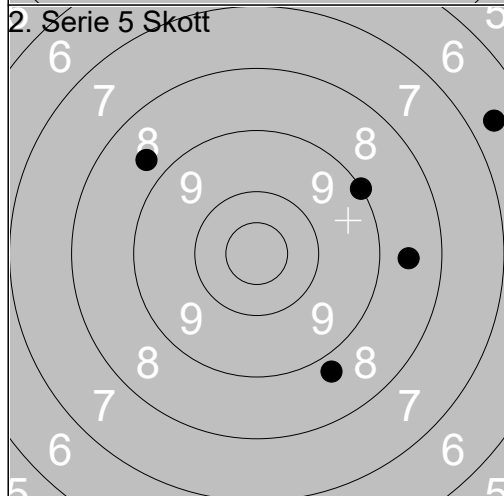

1:	8.6	→
2:	9.0	↗
3:	8.8	↓
4:	8.7	↗
5:	6.6	↗
Serie		39.0
Total		86.0

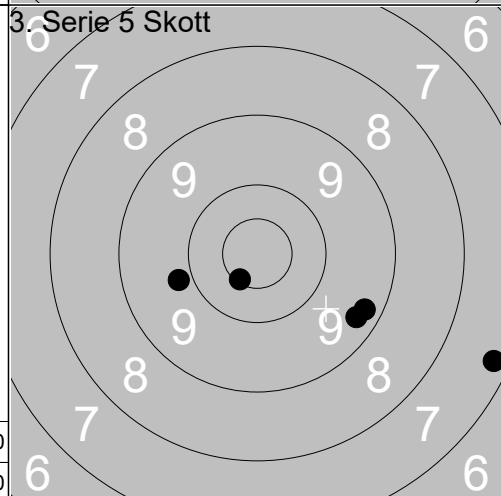

1:	9.8	←
2:	9.3	↘
3:	10.5x	↘
4:	9.3	↘
5:	7.3	↘
Serie		44.0
Total		130.0

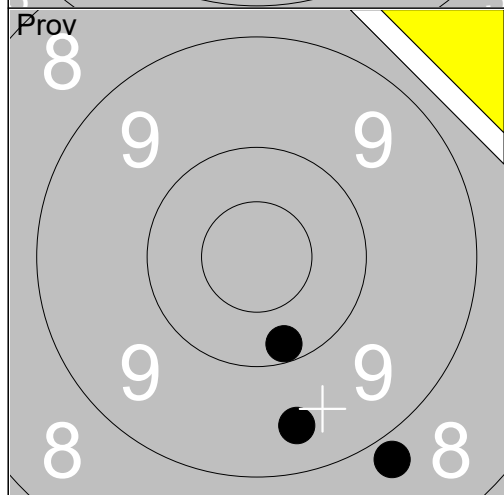

1:	8.8	↘
2:	10.2	↘
3:	9.5	↘
Serie		27.0
Total		130.0

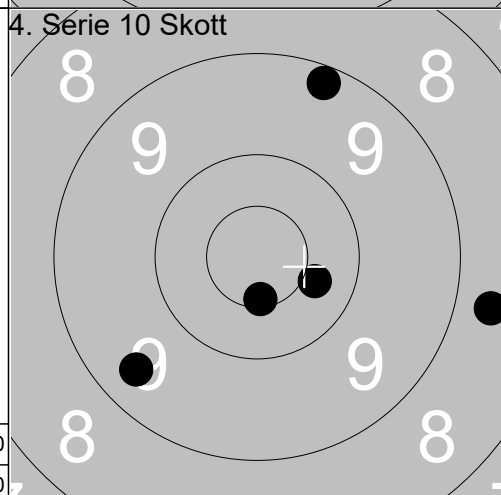

1:	9.2	↑
2:	8.7	→
3:	9.4	↙
4:	10.6x	↓
5:	10.4	↘
Serie		46.0
Total		176.0

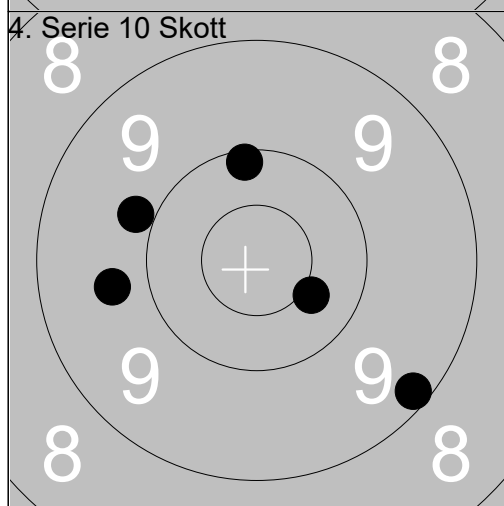

6:	9.2	↘
7:	10.1	↑
8:	9.7	←
9:	9.9	↙
10:	10.4	↘
Serie		47.0
Total		223.0

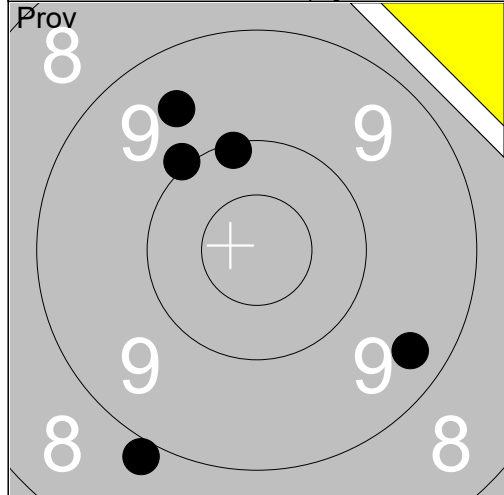

1:	9.6	↗
2:	10.0	↗
3:	9.4	↘
4:	10.1	↗
5:	8.9	↘
Serie		46.0
Total		0.0

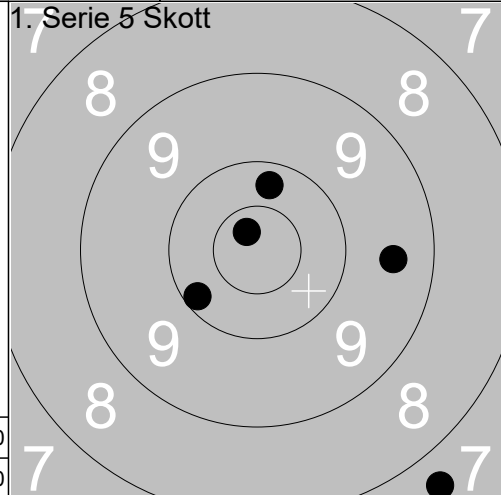

1:	10.7x	↗
2:	7.7	↘
3:	10.3	↗
4:	9.5	→
5:	10.2	↙
Serie		46.0
Total		46.0

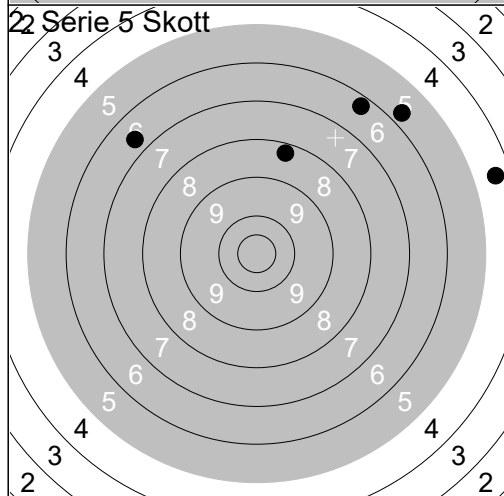

1:	6.7	↘
2:	5.7	↗
3:	8.3	↗
4:	4.4	→
5:	6.3	↗
Serie		29.0
Total		75.0

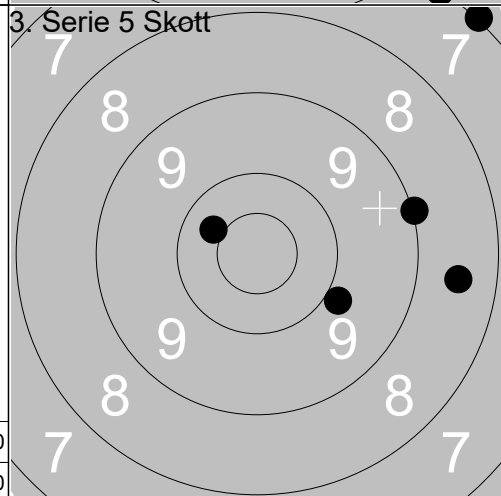

1:	7.0	↗
2:	8.5	→
3:	10.4	↗
4:	9.0	→
5:	9.9	↘
Serie		43.0
Total		118.0

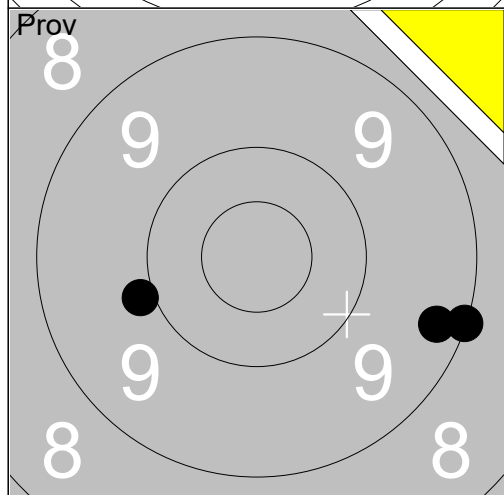

1:	9.3	→
2:	9.0	→
3:	9.9	←
Serie		27.0
Total		118.0

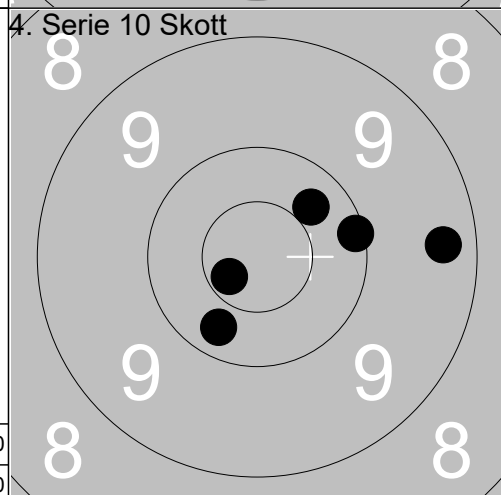

1:	10.3	↘
2:	10.7x	↙
3:	10.1	→
4:	10.3	↗
5:	9.3	→
Serie		49.0
Total		167.0

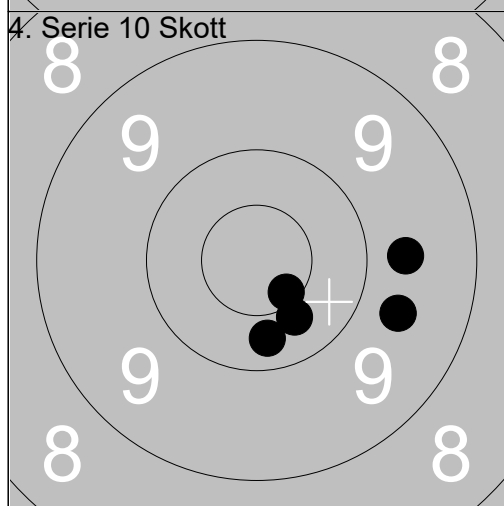

6:	9.7	→
7:	10.3	↘
8:	9.7	→
9:	10.6x	↘
10:	10.4	↘
Serie		48.0
Total		215.0

<p>Prov</p>	<p>1. Serie 5 Skott</p>	
1: 10.0 ← 2: 9.0 ↑ 3: 9.6 ↑ 4: 9.2 → 5: 10.5x ↗	1: 9.2 ↗ 2: 10.5x ↘ 3: 10.0 → 4: 9.5 ↗ 5: 9.4 ↘	
Serie 47.0 Total 0.0	Serie 47.0 Total 47.0	

<p>2. Serie 5 Skott</p>	<p>3. Serie 5 Skott</p>	
1: 6.4 ↑ 2: 9.1 → 3: 4.0 ↓ 4: 0.0 ↗ 5: 4.9 ↘	1: 9.8 ↗ 2: 5.9 ← 3: 7.7 ← 4: 10.1 ↓ 5: 10.3 →	
Serie 23.0 Total 70.0	Serie 41.0 Total 111.0	

<p>Prov</p>	<p>4. Serie 10 Skott</p>	
1: 9.8 ↗ 2: 10.6x ← 3: 10.4 ↓	1: 9.5 ↗ 2: 10.4 ↘ 3: 8.9 → 4: 10.0 → 5: 9.7 ↘	
Serie 29.0 Total 111.0	Serie 46.0 Total 157.0	

<p>4. Serie 10 Skott</p>		
6: 10.6x ↗ 7: 10.2 ↘ 8: 10.4 ← 9: 9.1 ↓ 10: 7.8 ↓		
Serie 46.0 Total 203.0		

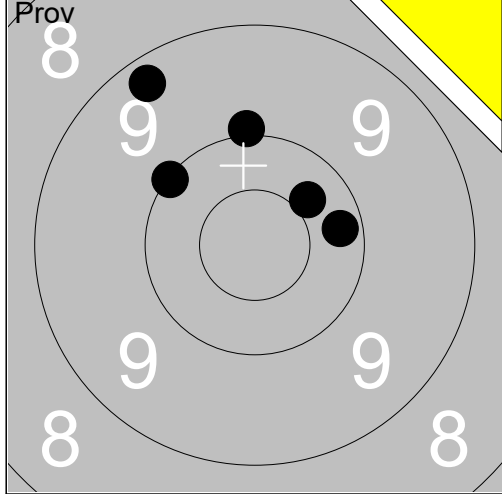

1:	9.3	↗
2:	10.0	↗
3:	10.0	↑
4:	10.2	→
5:	10.4	↗
Serie		49.0
Total		0.0

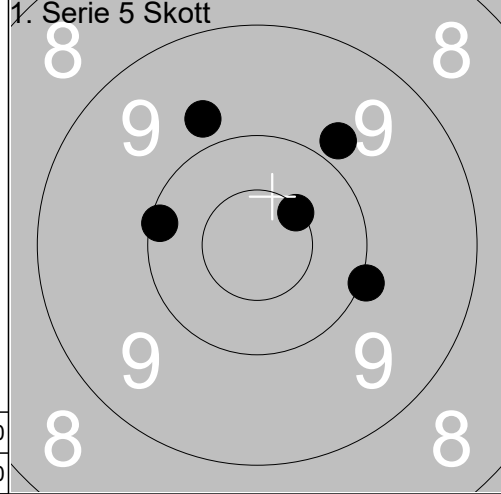

1:	10.5x	↗
2:	9.8	↗
3:	9.8	↑
4:	10.0	→
5:	10.1	↖
Serie		48.0
Total		48.0

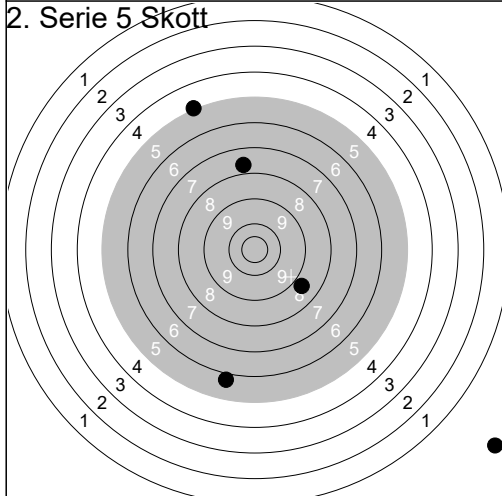

1:	0.0	↘
2:	5.0	↗
3:	5.8	↘
4:	7.7	↑
5:	8.7	↘
Serie		25.0
Total		73.0

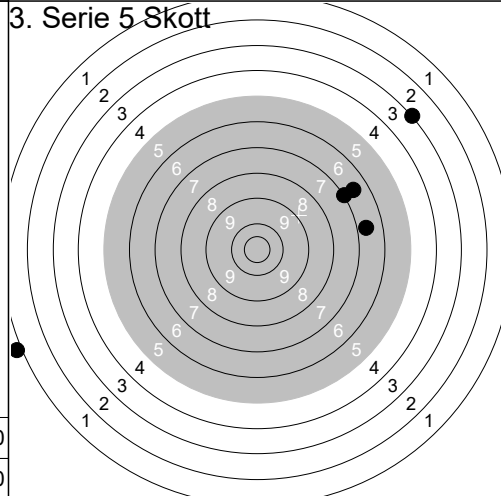

1:	6.6	↗
2:	0.0	↖
3:	3.0	↗
4:	6.7	→
5:	7.0	↗
Serie		22.0
Total		95.0

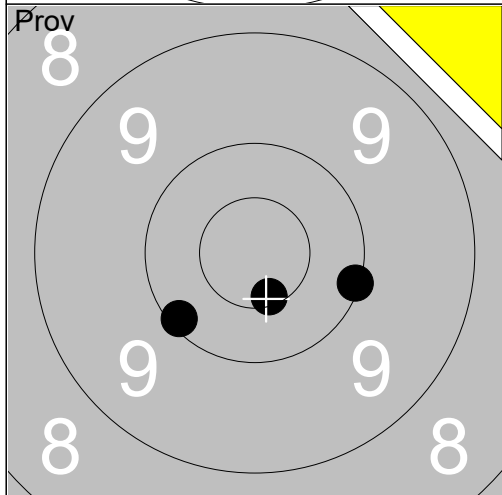

1:	10.1	→
2:	10.6x	↘
3:	10.1	↖
Serie		30.0
Total		95.0

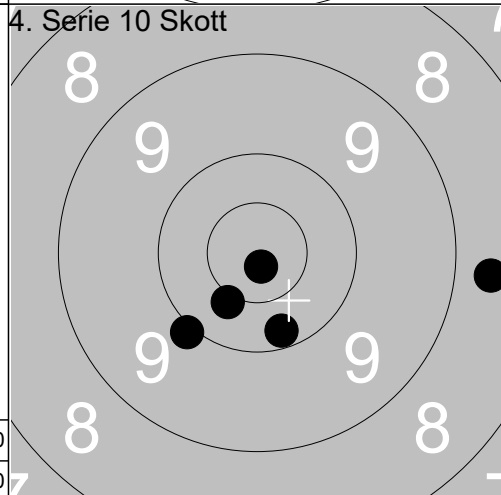

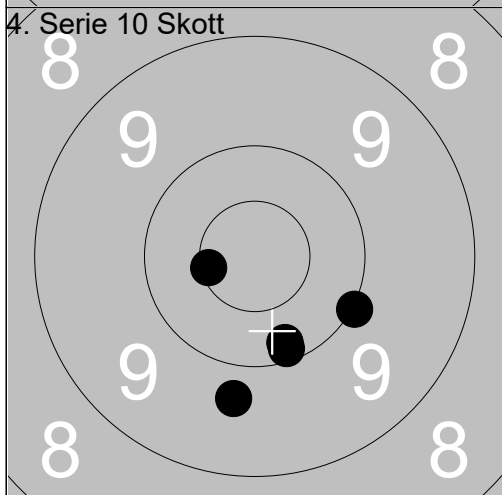

1:	8.7	→
2:	10.2	↘
3:	10.8x	↘
4:	10.0	↘
5:	10.4x	↘
Serie		48.0
Total		143.0

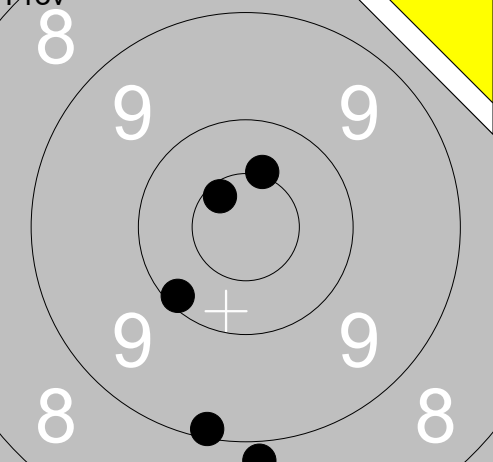
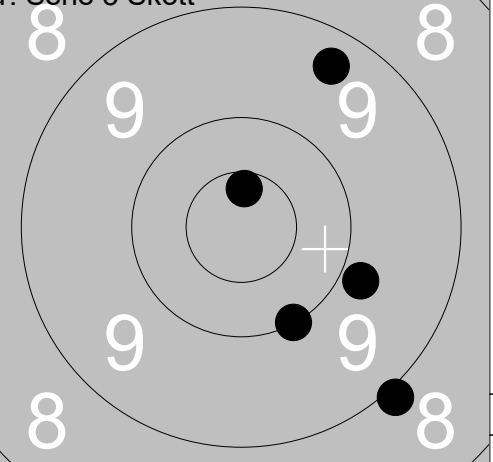

6:	10.6x	↖
7:	10.0	↘
8:	10.1	↘
9:	10.2	↘
10:	9.7	↘
Serie		49.0
Total		192.0

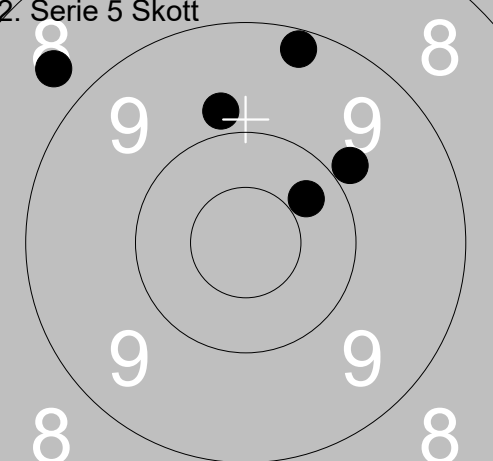
<p>Prov</p> 	<p>1: 8.8 ↓ 2: 10.1 ↙ 3: 10.6x ↘ 4: 10.5x ↑ 5: 9.1 ↓</p>	<p>1. Serie 5 Skott</p> 	<p>1: 10.0 ↓ 2: 8.9 ↓ 3: 9.8 ↘ 4: 10.6x ↑ 5: 9.4 ↗</p>
Serie 47.0		Serie 46.0	
Total 0.0		Total 46.0	

<p>2. Serie 5 Skott</p> 	<p>1: 9.8 ↑ 2: 10.3 ↗ 3: 9.9 ↗ 4: 8.7 ↖ 5: 9.2 ↑</p>	<p>3. Serie 5 Skott</p> 	<p>1: 10.1 ↗ 2: 8.9 ↓ 3: 10.3 ↑ 4: 9.6 ↗ 5: 8.8 ↑</p>
Serie 45.0		Serie 45.0	
Total 91.0		Total 136.0	

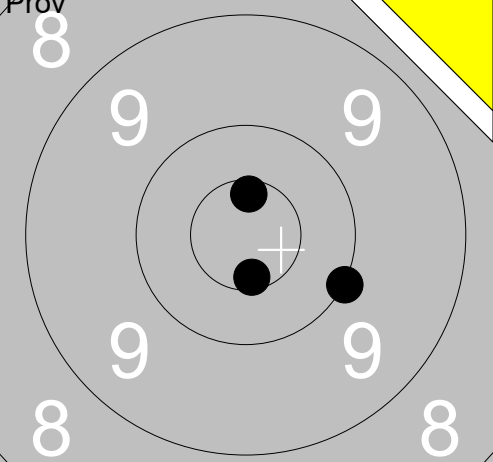
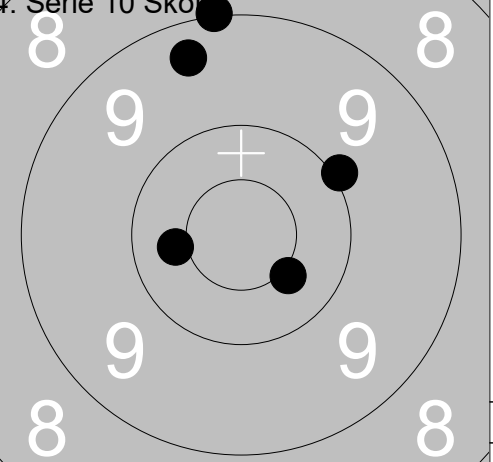
<p>Prov</p> 	<p>1: 10.6x ↑ 2: 10.0 → 3: 10.6x ↓</p>	<p>4. Serie 10 Skott</p> 	<p>1: 10.4 ← 2: 9.3 ↑ 3: 10.0 ↗ 4: 9.0 ↑ 5: 10.4x ↓</p>
Serie 30.0		Serie 48.0	
Total 136.0		Total 184.0	

<p>4. Serie 10 Skott</p> 	<p>6: 10.6x ← 7: 10.2 ↑ 8: 9.4 ↑ 9: 10.3 ↑ 10: 10.6x →</p>		
Serie 49.0			
Total 233.0			

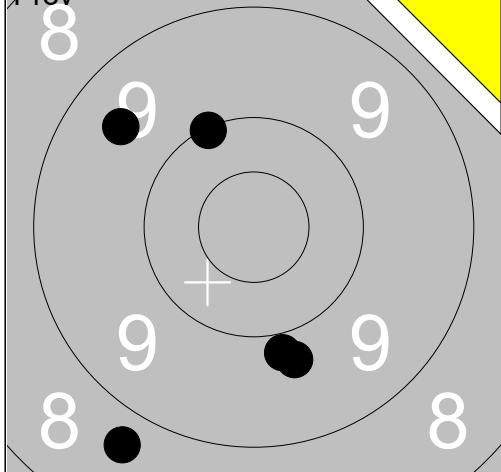

1:	9.9	↓
2:	10.0	↗
3:	9.5	↗
4:	8.7	↓
5:	9.8	↓
Serie		45.0
Total		0.0

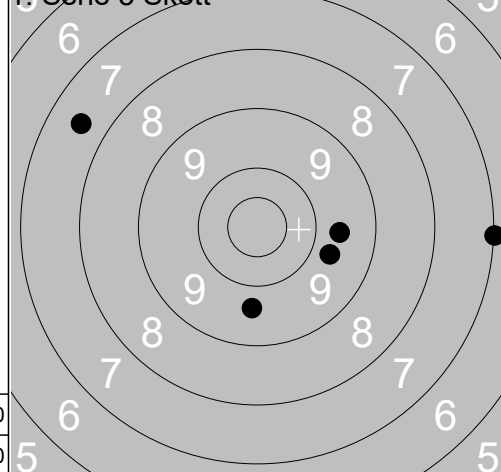

1:	9.7	↓
2:	9.6	→
3:	7.0	→
4:	9.7	↘
5:	7.6	↗
Serie		41.0
Total		41.0

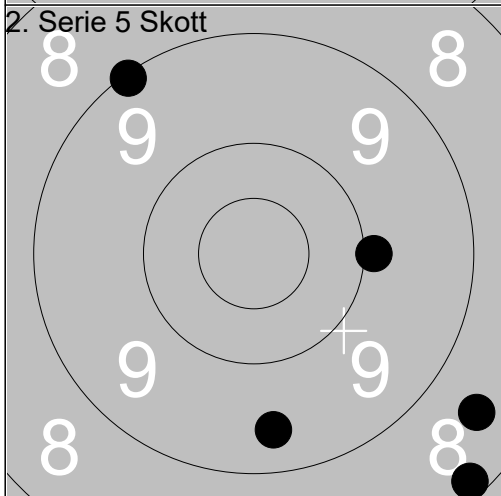

1:	8.5	↘
2:	8.2	↘
3:	9.4	↘
4:	9.9	→
5:	9.1	↗
Serie		43.0
Total		84.0

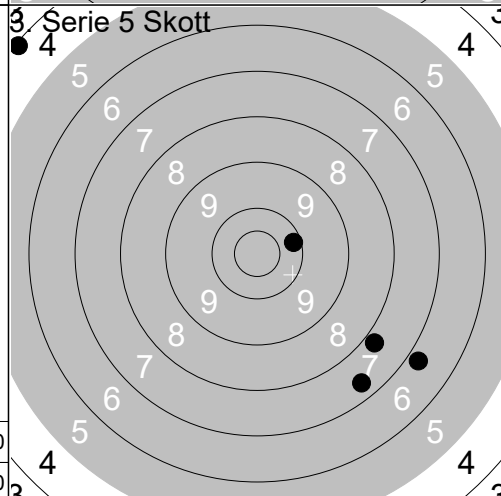

1:	7.4	↘
2:	7.8	↘
3:	6.8	↘
4:	10.2	→
5:	4.1	↗
Serie		34.0
Total		118.0

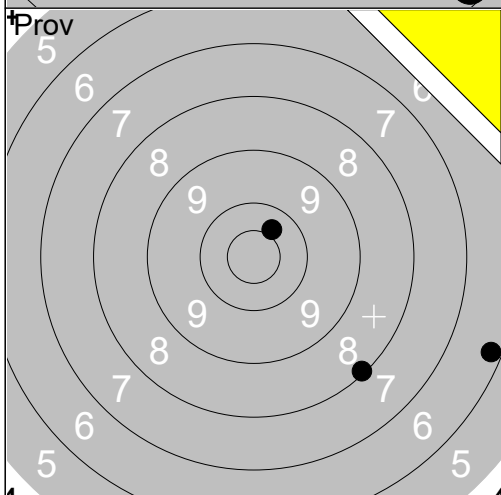

1:	6.2	→
2:	10.4	↗
3:	8.1	↘
Serie		24.0
Total		118.0

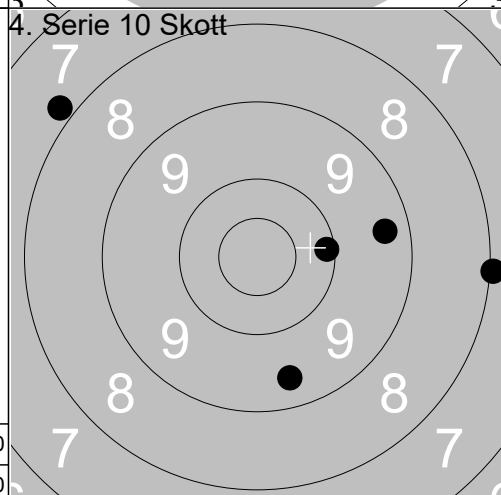

1:	9.3	→
2:	10.1	→
3:	8.0	→
4:	7.8	↗
5:	9.4	↓
Serie		43.0
Total		161.0

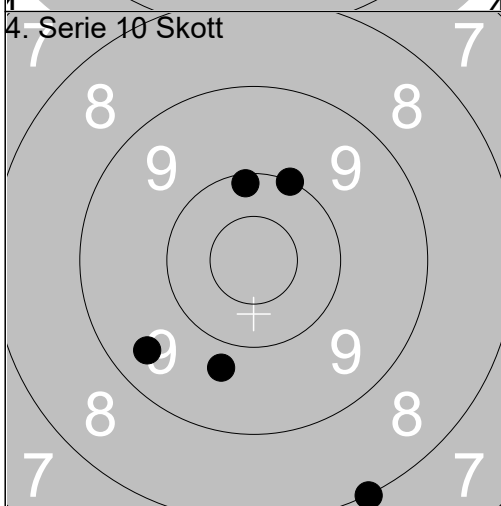

6:	10.0	↗
7:	9.4	↘
8:	9.7	↓
9:	8.0	↓
10:	10.1	↑
Serie		46.0
Total		207.0

<p>Prov</p>	<p>1: 8.1 ↗ 2: 6.9 ↗ 3: 7.9 ↗ 4: 10.4 ↗ 5: 10.7x ↘</p>	<p>1. Serie 5 Skott</p>	<p>1: 8.8 ↗ 2: 8.7 → 3: 9.7 → 4: 7.3 → 5: 9.3 ↑</p>
Serie 41.0	Total 0.0	Serie 41.0	Total 41.0

<p>2. Serie 5 Skott</p>	<p>1: 10.1 → 2: 10.3 ↗ 3: 10.4x ↗ 4: 9.0 ↓ 5: 8.6 →</p>	<p>3. Serie 5 Skott</p>	<p>1: 9.8 → 2: 8.3 → 3: 9.3 → 4: 10.1 ↗ 5: 9.9 ↓</p>
Serie 47.0	Total 88.0	Serie 45.0	Total 133.0

<p>Prov</p>	<p>1: 8.1 ↓ 2: 7.0 ↓ 3: 8.4 →</p>	<p>4. Serie 10 Skott</p>	<p>1: 9.8 ↘ 2: 9.0 ↑ 3: 9.7 ↗ 4: 10.6x ↘ 5: 9.7 ↘</p>
Serie 23.0	Total 133.0	Serie 46.0	Total 179.0

<p>4. Serie 10 Skott</p>	<p>6: 9.2 ← 7: 7.7 ↘ 8: 10.4x ↓ 9: 10.5x ↑ 10: 10.4x ↓</p>		
Serie 46.0	Total 225.0		

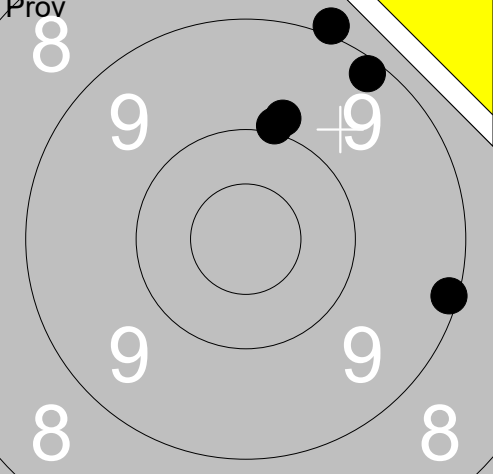
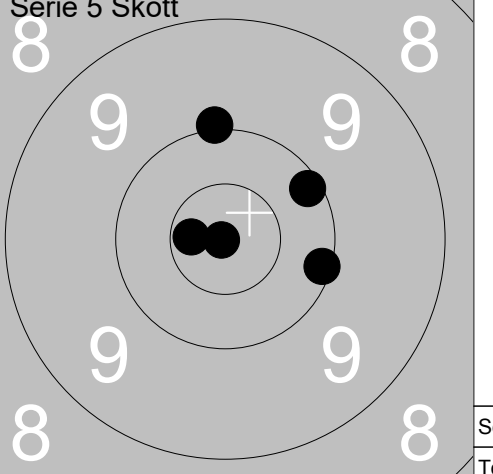
<p>Prov</p> 	<p>1: 9.2 ↗ 2: 9.9 ↑ 3: 8.9 ↑ 4: 10.0 ↑ 5: 9.1 →</p> <p>Serie 45.0 Total 0.0</p>	<p>1. Serie 5 Skott</p> 	<p>1: 10.0 ↑ 2: 10.1 ↗ 3: 10.9x ← 4: 10.1 → 5: 10.7x ←</p> <p>Serie 50.0 Total 50.0</p>
--	--	--	---

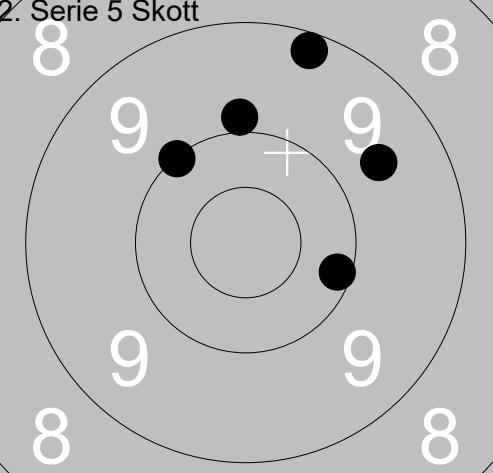
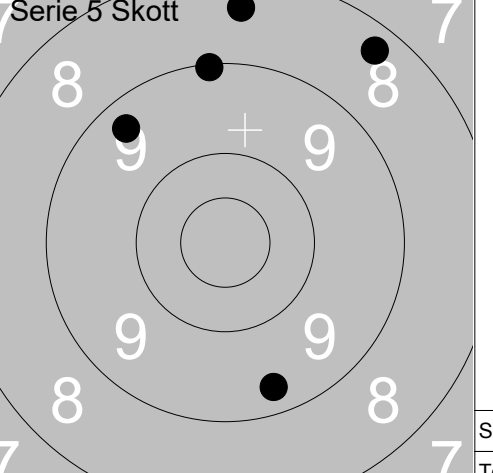
<p>2. Serie 5 Skott</p> 	<p>1: 9.6 ↗ 2: 10.1 → 3: 10.0 ↗ 4: 9.2 ↑ 5: 9.9 ↑</p> <p>Serie 47.0 Total 97.0</p>	<p>3. Serie 5 Skott</p> 	<p>1: 9.3 ↓ 2: 9.1 ↑ 3: 8.3 ↗ 4: 8.4 ↑ 5: 9.3 ↗</p> <p>Serie 43.0 Total 140.0</p>
---	--	---	---

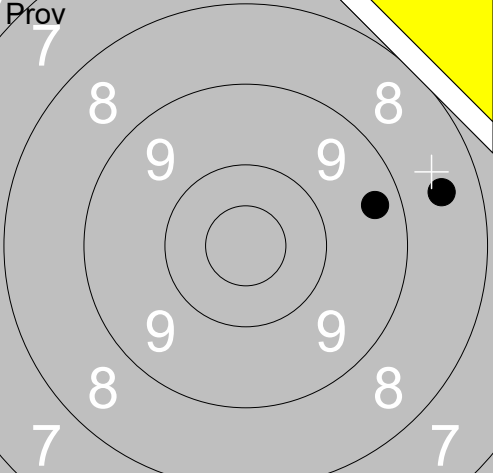
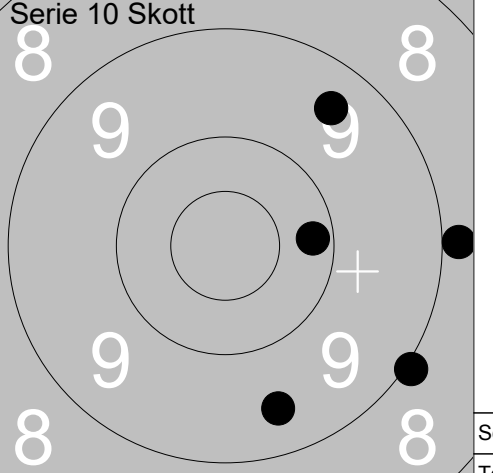
<p>Prov</p> 	<p>1: 7.7 ↗ 2: 8.5 → 3: 9.3 →</p> <p>Serie 24.0 Total 140.0</p>	<p>4. Serie 10 Skott</p> 	<p>1: 8.9 → 2: 9.0 ↘ 3: 9.4 ↗ 4: 10.2 → 5: 9.5 ↓</p> <p>Serie 45.0 Total 185.0</p>
--	---	---	--

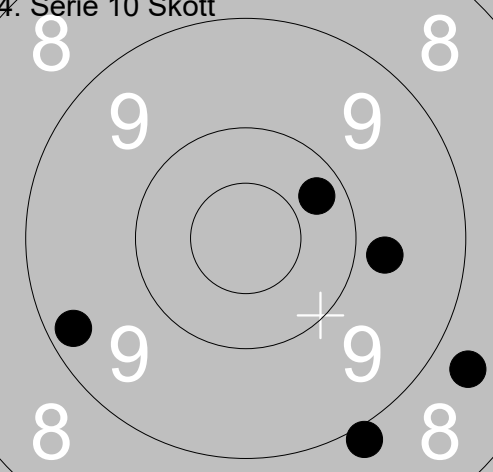
<p>4. Serie 10 Skott</p> 	<p>6: 10.3 ↗ 7: 9.3 ← 8: 8.7 ↘ 9: 8.9 ↓ 10: 9.8 →</p> <p>Serie 44.0 Total 229.0</p>		
---	---	--	--

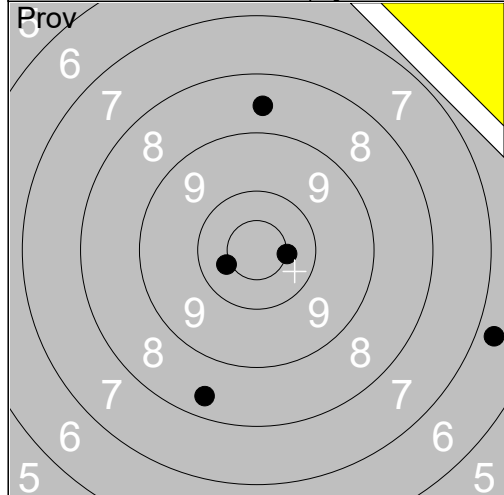

1:	6.7	→
2:	8.6	↑
3:	10.4x	←
4:	10.5x	→
5:	8.4	↓
Serie		42.0
Total		0.0

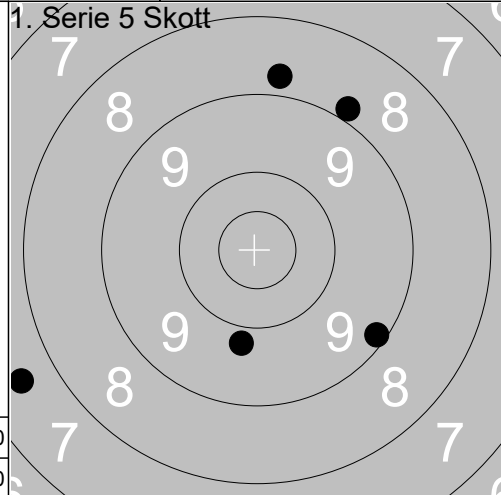

1:	8.8	↑
2:	8.9	↗
3:	9.1	↘
4:	7.6	←
5:	9.8	↓
Serie		41.0
Total		41.0

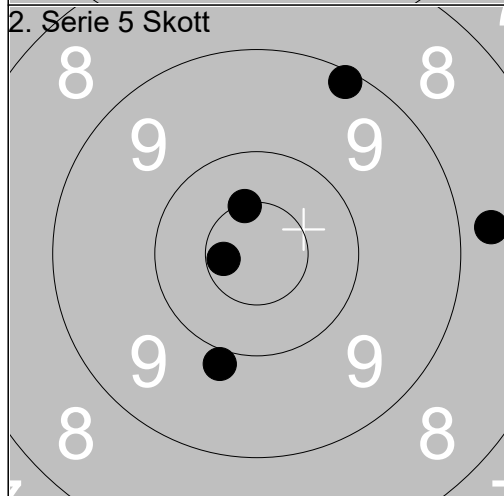

1:	10.5x	↑
2:	8.7	→
3:	10.6x	←
4:	9.9	↓
5:	9.1	↗
Serie		46.0
Total		87.0

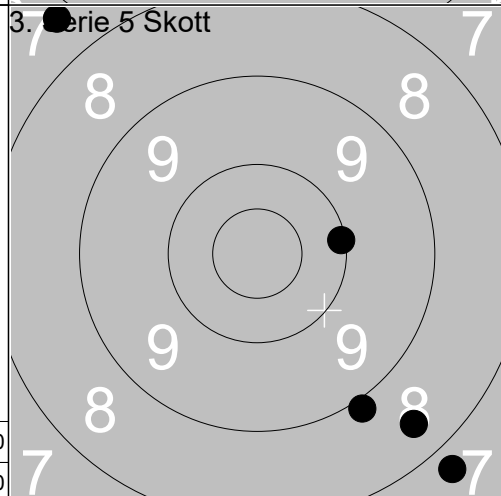

1:	8.9	↘
2:	10.1	→
3:	7.8	↘
4:	8.4	↘
5:	7.6	↗
Serie		40.0
Total		127.0

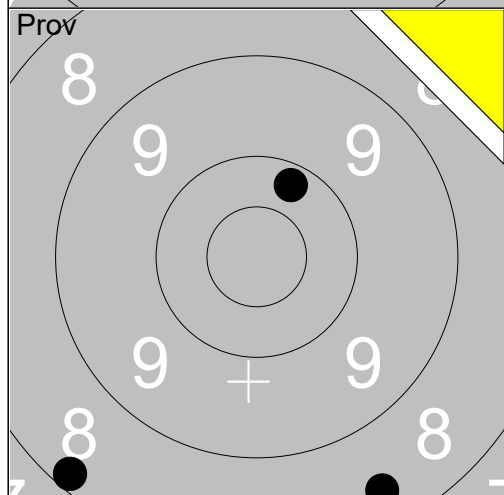

1:	10.2	↗
2:	8.4	↘
3:	8.2	↘
Serie		26.0
Total		127.0

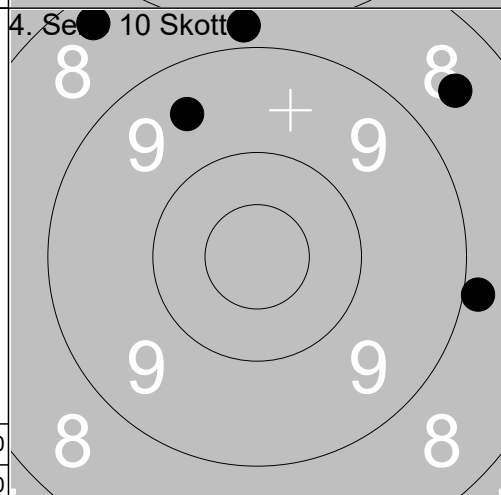

1:	9.5	↗
2:	8.3	↗
3:	8.9	→
4:	8.8	↑
5:	8.6	↗
Serie		41.0
Total		168.0

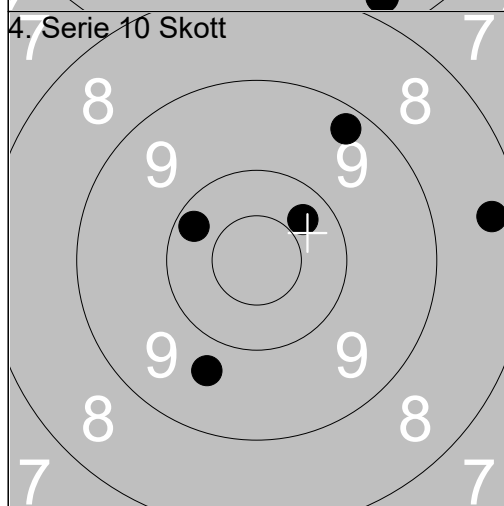

6:	9.3	↗
7:	8.4	→
8:	10.3	↗
9:	10.2	↖
10:	9.7	↓
Serie		46.0
Total		214.0

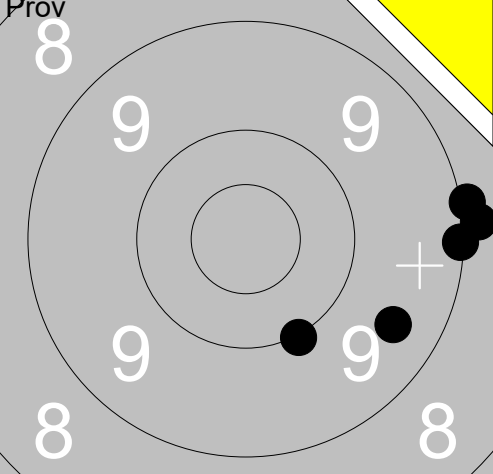
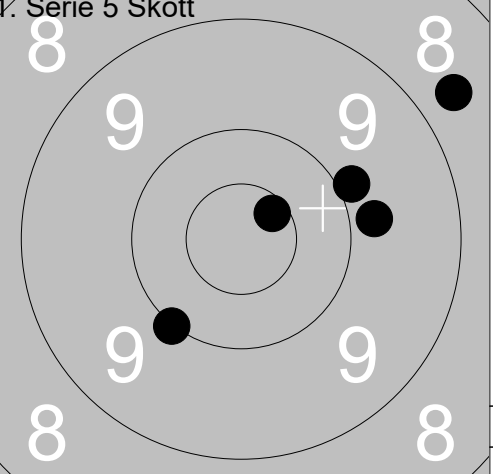
<p>Prov</p> 	<p>1: 8.9 →</p> <p>2: 9.0 →</p> <p>3: 10.0 ↓</p> <p>4: 9.5 ↓</p> <p>5: 9.1 →</p>	<p>1. Serie 5 Skott</p> 	<p>1: 9.9 ↗</p> <p>2: 8.7 ↗</p> <p>3: 10.0 ↓</p> <p>4: 10.6x ↗</p> <p>5: 9.8 →</p>
Serie 45.0		Serie 46.0	
Total 0.0		Total 46.0	

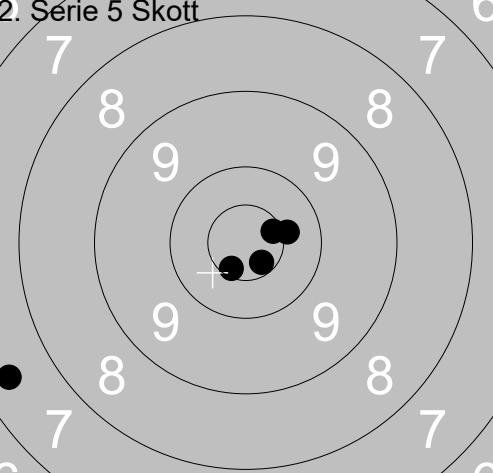
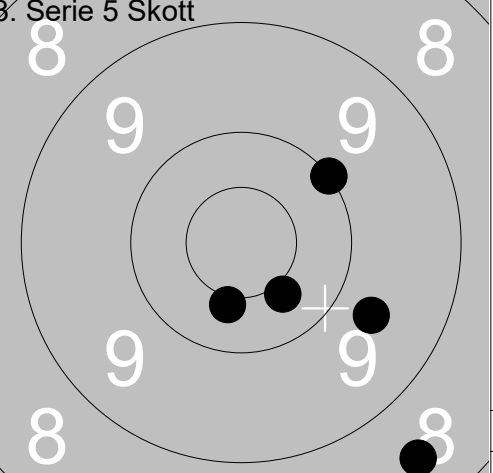
<p>2. Serie 5 Skott</p> 	<p>1: 10.6x ↗</p> <p>2: 10.6x ↓</p> <p>3: 7.4 ←</p> <p>4: 10.6x ↓</p> <p>5: 10.4x →</p>	<p>3. Serie 5 Skott</p> 	<p>1: 10.4 ↓</p> <p>2: 9.7 →</p> <p>3: 8.5 ↓</p> <p>4: 10.4x ↓</p> <p>5: 10.0 ↗</p>
Serie 47.0		Serie 47.0	
Total 93.0		Total 140.0	

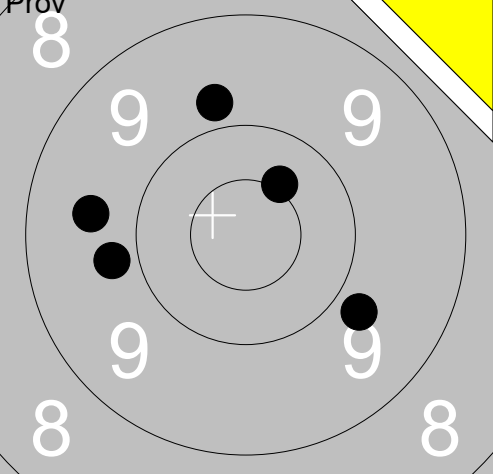
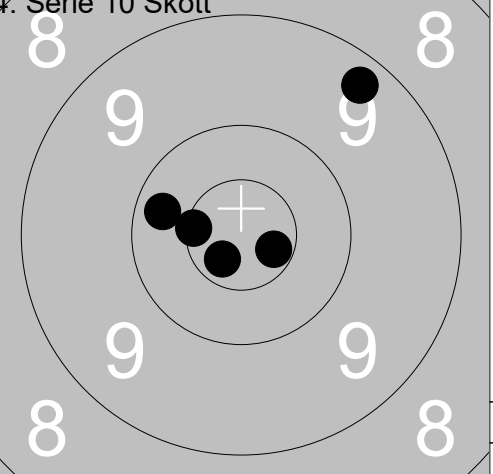
<p>Prov</p> 	<p>1: 10.4x ↗</p> <p>2: 9.8 ↑</p> <p>3: 9.8 ←</p> <p>4: 9.6 ←</p> <p>5: 9.8 ↓</p>	<p>4. Serie 10 Skott</p> 	<p>1: 9.3 ↗</p> <p>2: 10.7x →</p> <p>3: 10.7x ↓</p> <p>4: 10.5x ←</p> <p>5: 10.3 ←</p>
Serie 46.0		Serie 49.0	
Total 140.0		Total 189.0	

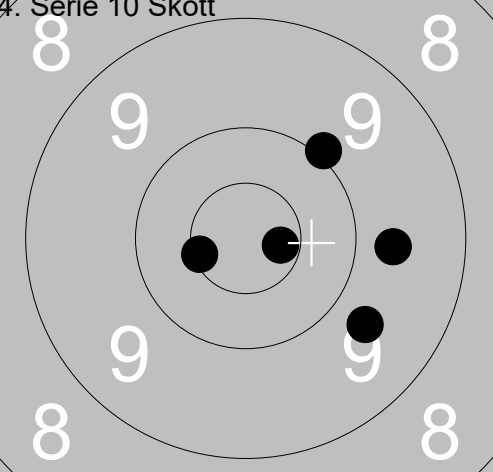
<p>4. Serie 10 Skott</p> 	<p>6: 10.0 ↗</p> <p>7: 10.7x →</p> <p>8: 9.7 ↓</p> <p>9: 10.5x ←</p> <p>10: 9.7 →</p>		
Serie 48.0			
Total 237.0			

<p>Pröv</p>	<p>1: 8.0 →</p> <p>2: 10.4x ↙</p> <p>3: 10.0 ←</p> <p>4: 9.2 ↙</p> <p>5: 8.5 ↓</p>	<p>1. Serie 5 Skott</p>	<p>1: 9.8 ↙</p> <p>2: 9.8 ↓</p> <p>3: 9.6 →</p> <p>4: 9.2 ↙</p> <p>5: 10.2 ↓</p>
Serie 45.0	Total 0.0	Serie 46.0	Total 46.0

<p>2. Serie 5 Skott</p>	<p>1: 10.3 ↑</p> <p>2: 9.6 ↙</p> <p>3: 8.2 ↓</p> <p>4: 8.8 ↓</p> <p>5: 10.7x ↑</p>	<p>3. Serie 5 Skott</p>	<p>1: 10.3 ↗</p> <p>2: 10.1 ↓</p> <p>3: 10.0 ↗</p> <p>4: 9.7 ↓</p> <p>5: 10.0 ↓</p>
Serie 45.0	Total 91.0	Serie 49.0	Total 140.0

<p>Pröv</p>	<p>1: 10.6x ↑</p> <p>2: 9.2 ↗</p> <p>3: 8.8 ↓</p>	<p>4. Serie 10 Skott</p>	<p>1: 8.4 ↗</p> <p>2: 9.5 ↓</p> <p>3: 9.4 ↓</p> <p>4: 10.2 ↓</p> <p>5: 10.2 →</p>
Serie 27.0	Total 140.0	Serie 46.0	Total 186.0

<p>4. Serie 10 Skott</p>	<p>6: 10.3 →</p> <p>7: 10.0 ↙</p> <p>8: 9.4 ↓</p> <p>9: 9.3 ↗</p> <p>10: 10.3 ↓</p>		
Serie 48.0	Total 234.0		

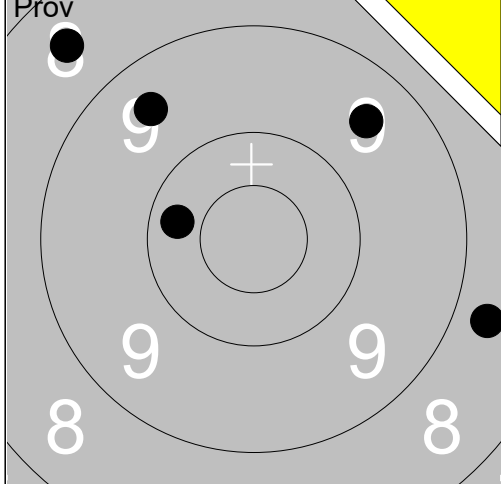

1:	8.5	↗
2:	9.5	↗
3:	10.3	↖
4:	9.5	↗
5:	8.7	↘
Serie		44.0
Total		0.0

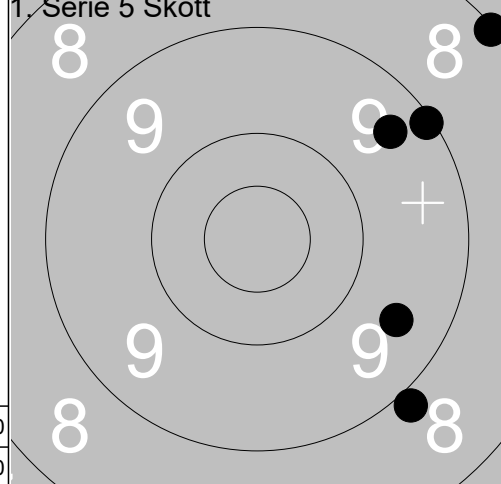

1:	9.4	↗
2:	9.5	↘
3:	8.9	↘
4:	8.1	↗
5:	9.1	↗
Serie		43.0
Total		43.0

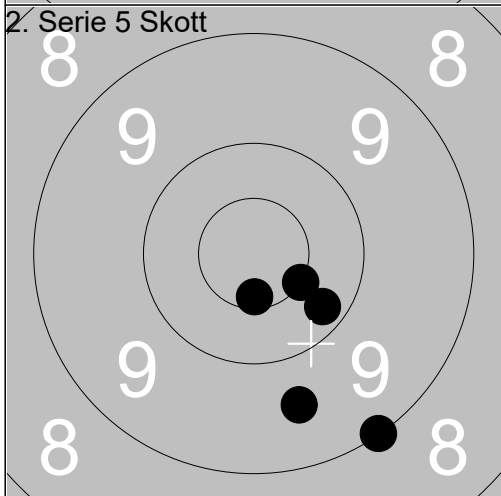

1:	10.2	↘
2:	9.6	↘
3:	10.6x	↘
4:	10.5x	↘
5:	9.0	↘
Serie		48.0
Total		91.0

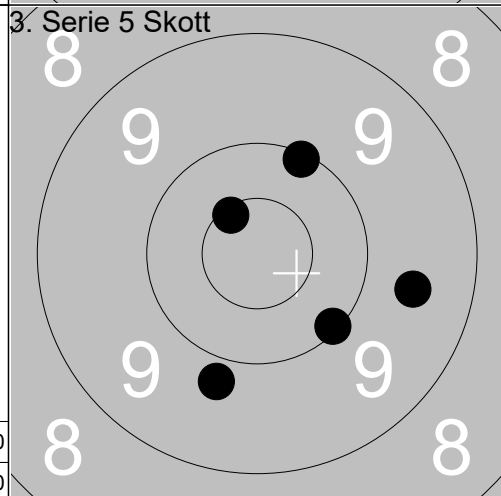

1:	10.6x	↗
2:	10.1	↘
3:	9.6	→
4:	9.8	↘
5:	10.1	↗
Serie		48.0
Total		139.0

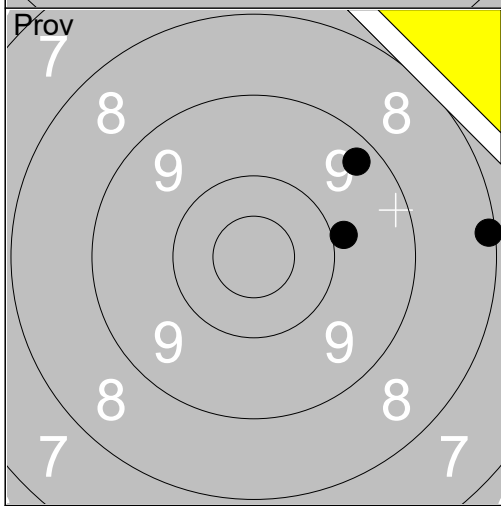

1:	9.3	↗
2:	9.9	→
3:	8.1	→
Serie		26.0
Total		139.0

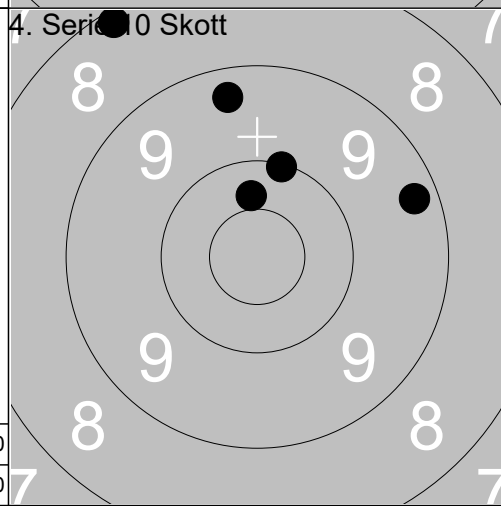

1:	9.3	→
2:	9.3	↑
3:	8.2	↖
4:	10.0	↑
5:	10.4	↑
Serie		46.0
Total		185.0

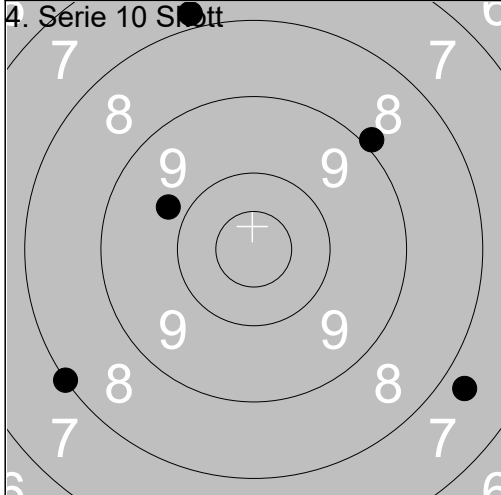

6:	9.8	↖
7:	7.7	↘
8:	8.9	↗
9:	8.0	↖
10:	7.8	↑
Serie		39.0
Total		224.0

	<p>1: 8.6 →</p> <p>2: 6.9 ↓</p> <p>3: 9.0 ←</p> <p>4: 9.0 ↗</p> <p>5: 8.8 ←</p>	<p>1. Serie 5 Skott</p> <p>1: 8.8 →</p> <p>2: 8.6 ↓</p> <p>3: 9.5 ↓</p> <p>4: 9.2 ↗</p> <p>5: 8.6 ↓</p>
Serie 40.0		Serie 42.0
Total 0.0		Total 42.0

<p>2. Serie 5 Skott</p>	<p>1: 9.8 ↖</p> <p>2: 3.7 ↓</p> <p>3: 9.7 ↗</p> <p>4: 9.4 →</p> <p>5: 8.5 ↑</p>	<p>3. Serie 5 Skott</p> <p>1: 8.8 ↗</p> <p>2: 10.3 →</p> <p>3: 8.0 ↑</p> <p>4: 9.7 ↖</p> <p>5: 8.5 →</p>
Serie 38.0		Serie 43.0
Total 80.0		Total 123.0

<p>Provschytte</p>	<p>1: 9.3 →</p> <p>2: 7.2 ↑</p> <p>3: 9.4 ↗</p>	<p>4. Serie 10 Skott</p> <p>1: 9.9 ↓</p> <p>2: 8.9 ←</p> <p>3: 9.9 ↓</p> <p>4: 8.1 ↖</p> <p>5: 9.7 ←</p>
Serie 25.0		Serie 43.0
Total 123.0		Total 166.0

<p>4. Serie 10 Skott</p>	<p>6: 8.7 ↗</p> <p>7: 7.4 →</p> <p>8: 9.2 ↗</p> <p>9: 9.4 ↓</p> <p>10: 8.2 ↗</p>	
Serie 41.0		
Total 207.0		

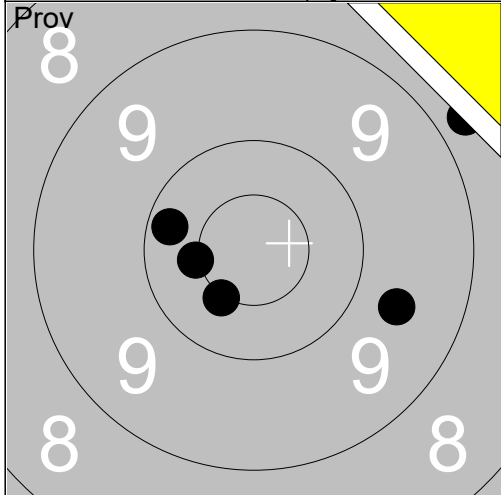

1:	10.2	↖
2:	10.5x	←
3:	10.5x	↙
4:	8.8	↗
5:	9.6	↘
Serie		47.0
Total		0.0

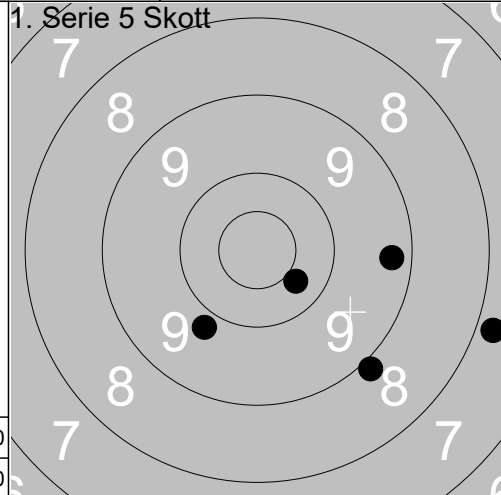

1:	9.8	↙
2:	8.9	↘
3:	7.8	↘
4:	10.4	↘
5:	9.3	→
Serie		43.0
Total		43.0

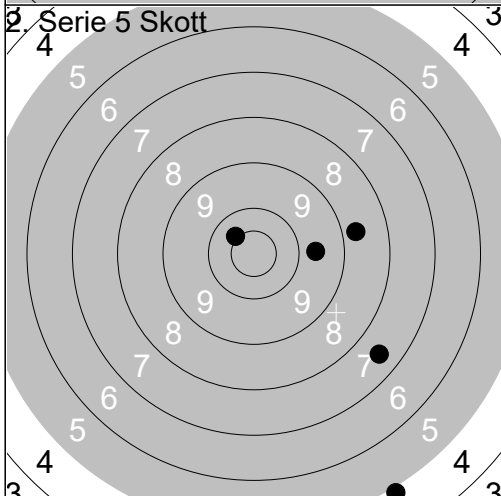

1:	7.5	↘
2:	8.7	→
3:	4.9	↘
4:	10.4x	↗
5:	9.7	→
Serie		38.0
Total		81.0

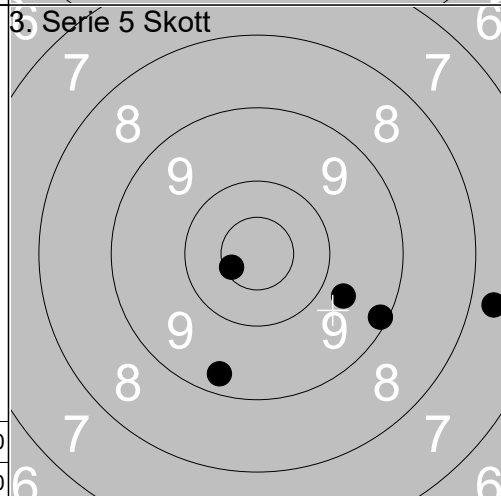

1:	9.1	↘
2:	7.7	→
3:	9.3	↘
4:	9.7	↘
5:	10.6x	↖
Serie		44.0
Total		125.0

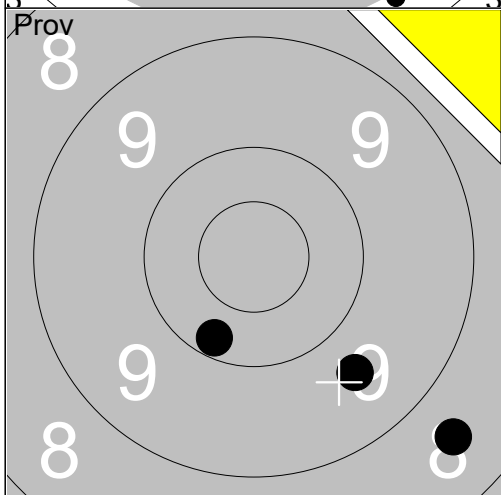

1:	8.6	↘
2:	10.2	↘
3:	9.6	↘
Serie		27.0
Total		125.0

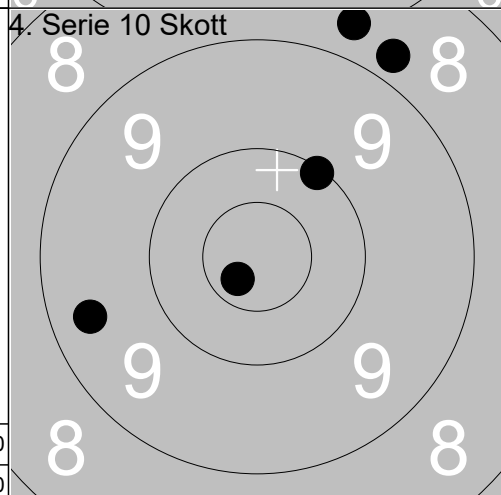

1:	9.4	↖
2:	10.1	↗
3:	8.8	↗
4:	10.7x	↘
5:	8.7	↗
Serie		45.0
Total		170.0

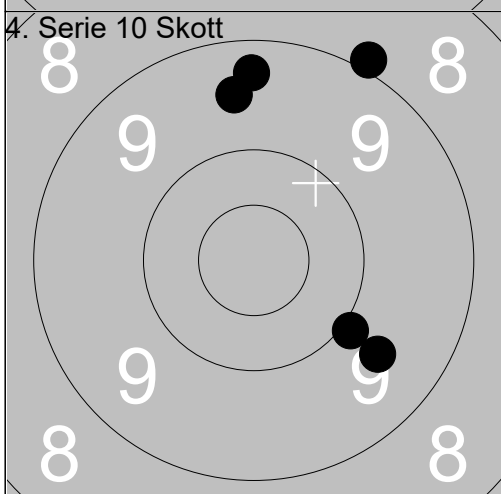

6:	9.5	↑
7:	9.3	↑
8:	9.6	↘
9:	8.9	↗
10:	9.9	↘
Serie		44.0
Total		214.0

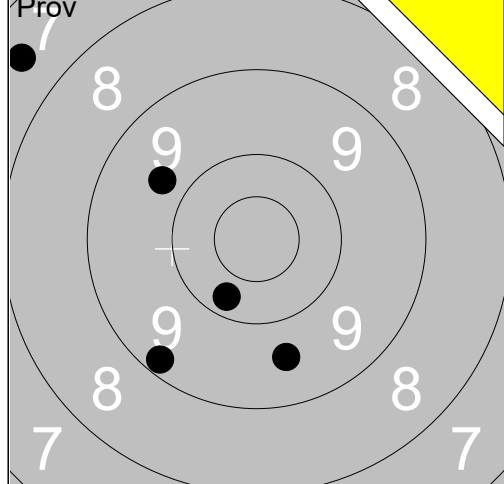

1:	7.5	↖
2:	9.6	↓
3:	9.2	↘
4:	10.2	↘
5:	9.7	↗
Serie		44.0
Total		0.0

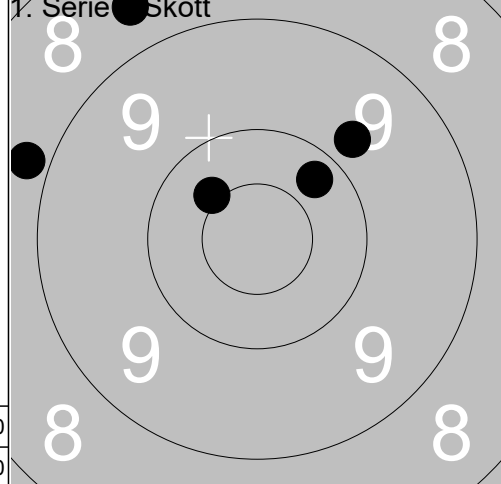

1:	8.8	↖
2:	10.3	↗
3:	8.6	↗
4:	9.8	↗
5:	10.4x	↖
Serie		45.0
Total		45.0

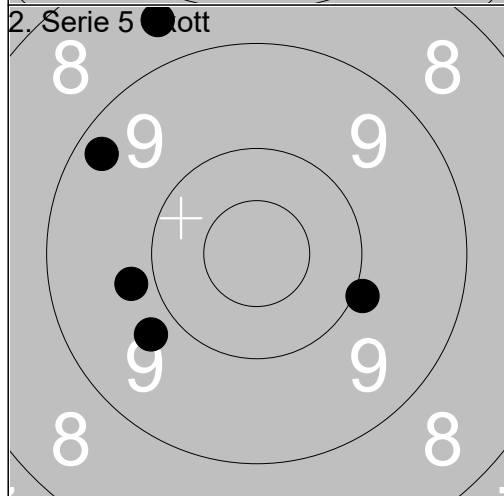

1:	9.8	↖
2:	9.3	↗
3:	8.6	↗
4:	9.9	↘
5:	9.8	↖
Serie		44.0
Total		89.0

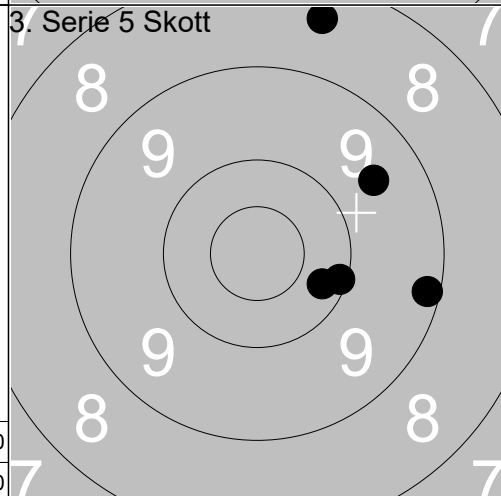

1:	10.1	→
2:	10.2	→
3:	9.6	↗
4:	9.2	→
5:	8.4	↑
Serie		46.0
Total		135.0

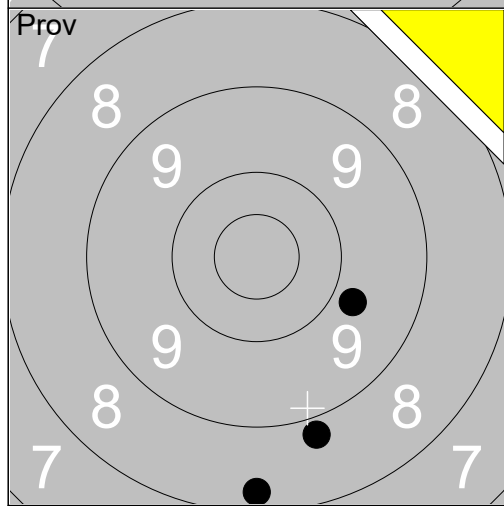

1:	9.8	↘
2:	8.8	↓
3:	8.3	↓
Serie		25.0
Total		135.0

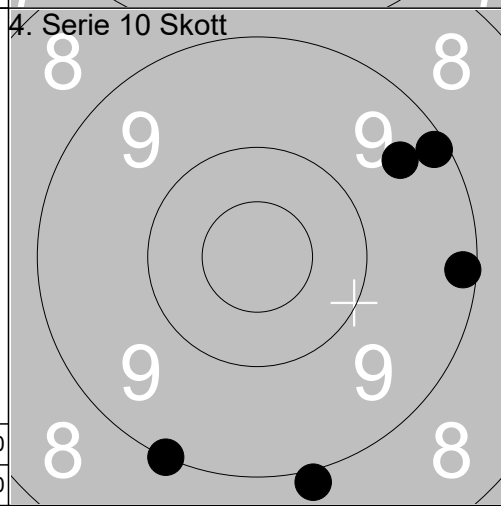

1:	9.0	↓
2:	8.9	↓
3:	9.2	→
4:	9.1	↗
5:	9.5	↗
Serie		44.0
Total		179.0

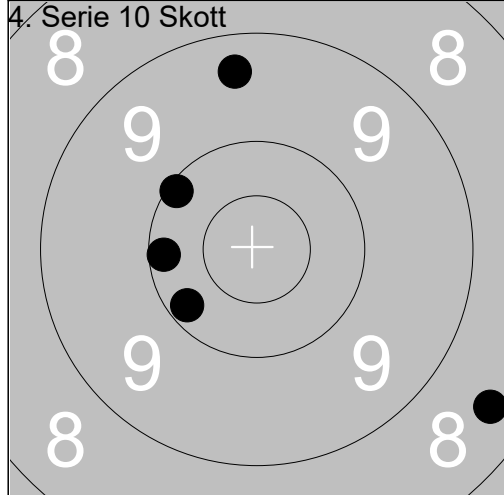

6:	10.2	↖
7:	9.4	↑
8:	10.1	↗
9:	10.2	↘
10:	8.4	↘
Serie		47.0
Total		226.0

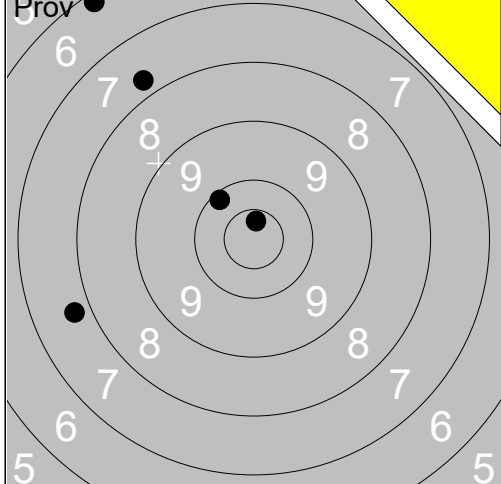

1:	6.2	↗
2:	7.7	↗
3:	10.7x	↑
4:	7.8	←
5:	10.1	↗

Serie	40.0
Total	0.0

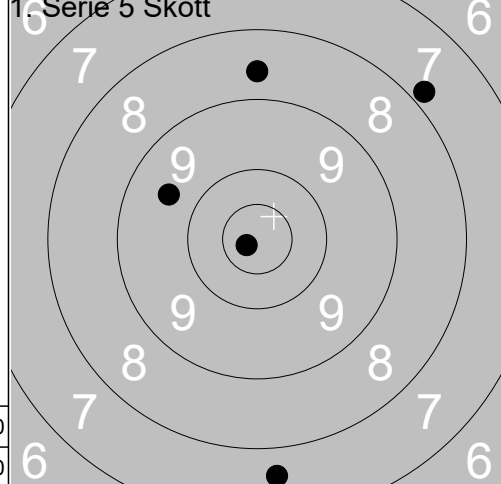

1:	10.8x	↙
2:	8.6	↑
3:	7.6	↓
4:	7.8	↗
5:	9.6	↙

Serie	41.0
Total	41.0

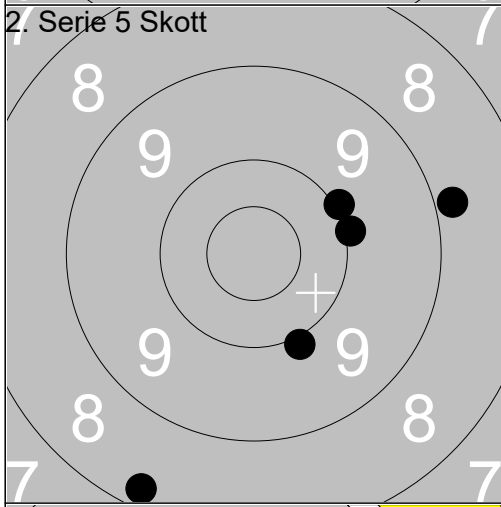

1:	8.2	↘
2:	10.0	→
3:	8.8	→
4:	10.0	↗
5:	9.9	↘

Serie	45.0
Total	86.0

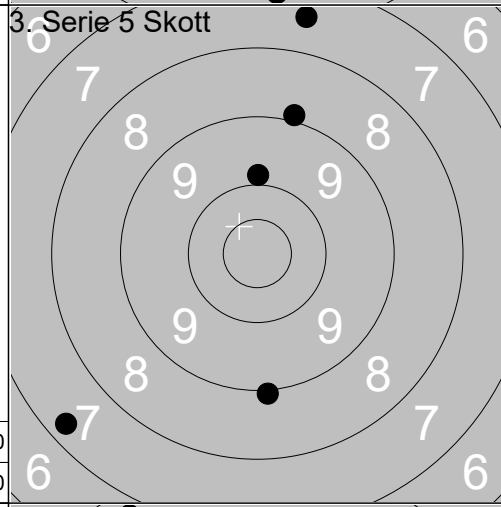

1:	9.0	↓
2:	8.9	↑
3:	9.9	↑
4:	7.5	↑
5:	7.3	↙

Serie	40.0
Total	126.0

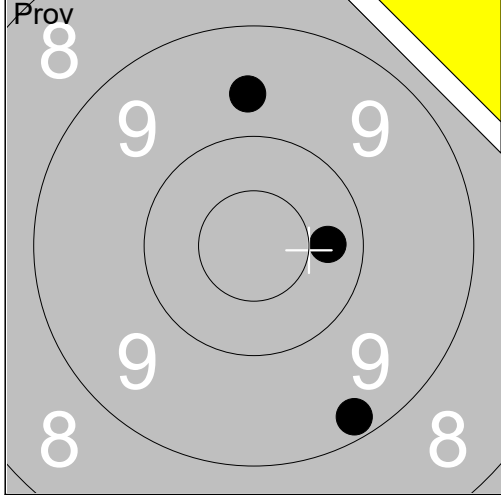

1:	10.3	→
2:	9.2	↘
3:	9.6	↑

Serie	28.0
Total	126.0

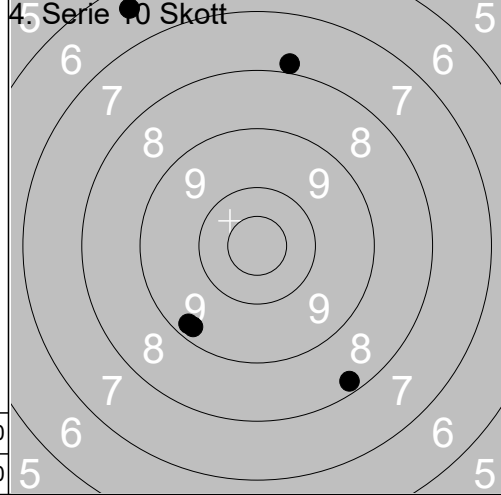

1:	9.3	↙
2:	8.2	↘
3:	7.9	↑
4:	6.4	↗
5:	9.3	↘

Serie	39.0
Total	165.0

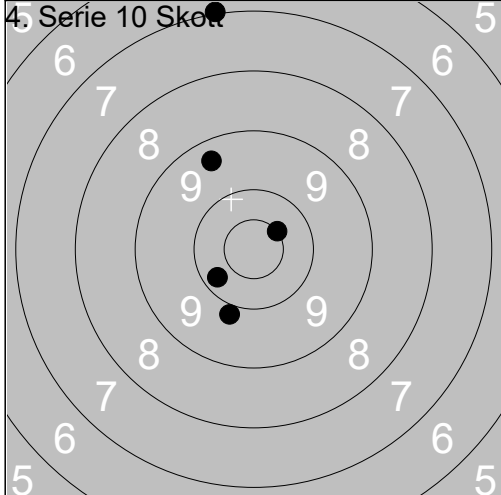

6:	10.2	↙
7:	10.5x	↗
8:	9.9	↘
9:	9.4	↗
10:	7.0	↑

Serie	45.0
Total	210.0

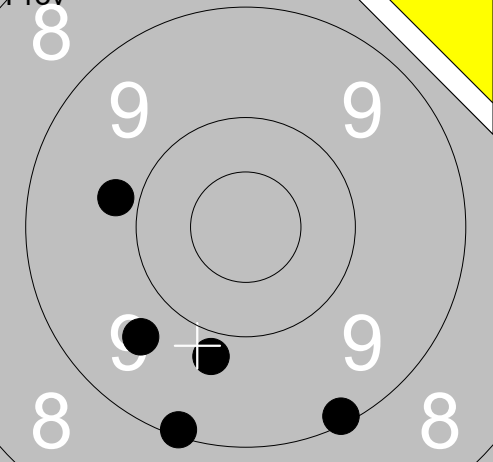
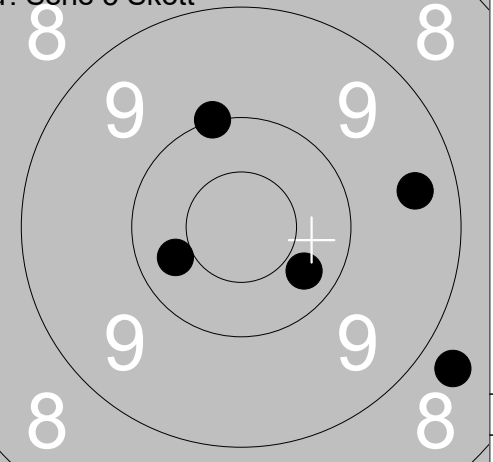
Prov 	1. Serie 5 Skott 	
1: 9.6 ↙ 2: 9.8 ↓ 3: 9.8 ← 4: 9.1 ↓ 5: 9.1 ↓	1: 10.3 ↘ 2: 9.4 → 3: 8.7 ↘ 4: 10.0 ↑ 5: 10.3 ←	
Serie 45.0 Total 0.0	Serie 47.0 Total 47.0	

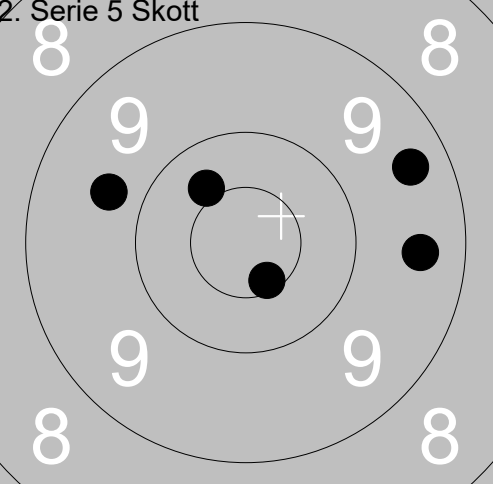
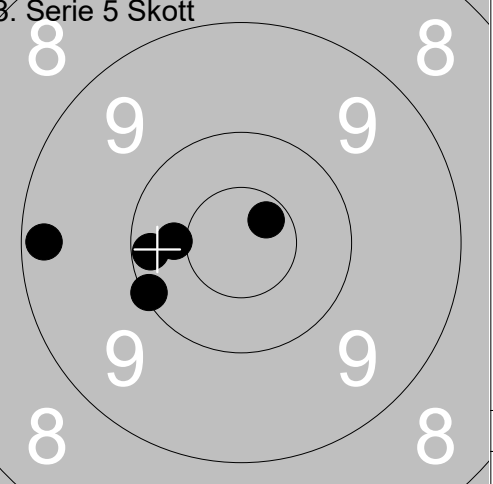
2. Serie 5 Skott 	3. Serie 5 Skott 	
1: 9.4 → 2: 9.4 → 3: 10.4 ↗ 4: 10.6x ↓ 5: 9.7 ↗	1: 10.7x ↗ 2: 10.1 ← 3: 10.2 ← 4: 10.4 ← 5: 9.2 ←	
Serie 47.0 Total 94.0	Serie 49.0 Total 143.0	

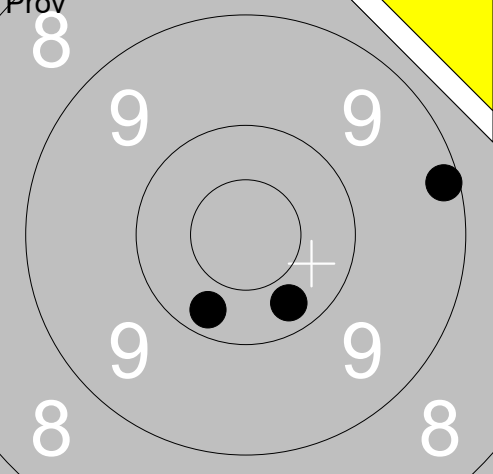
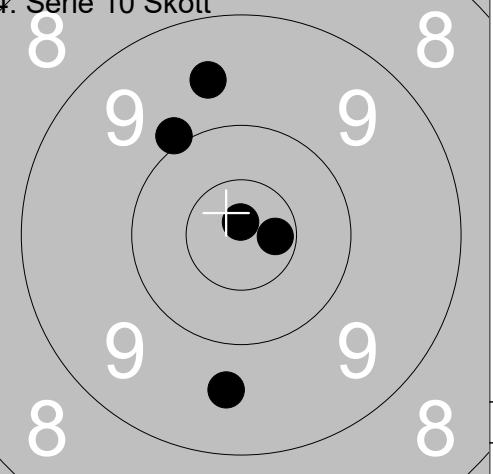
Prov 	4. Serie 10 Skott 	
1: 10.3 ↓ 2: 9.2 → 3: 10.2 ↓	1: 9.9 ↖ 2: 10.8x ↑ 3: 9.6 ↑ 4: 10.7x → 5: 9.6 ↓	
Serie 29.0 Total 143.0	Serie 47.0 Total 190.0	

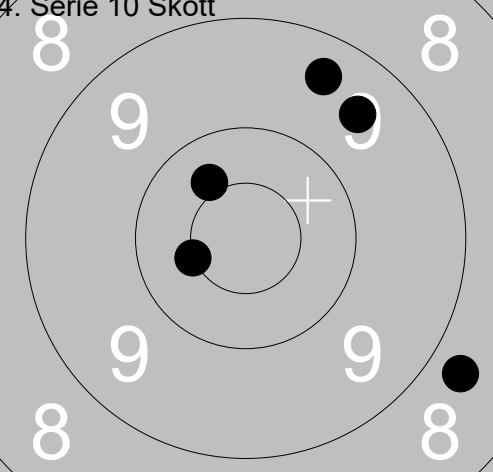
4. Serie 10 Skott 		
6: 10.4 ↖ 7: 9.4 ↗ 8: 10.5x ← 9: 9.5 ↗ 10: 8.7 ↘		
Serie 46.0 Total 236.0		

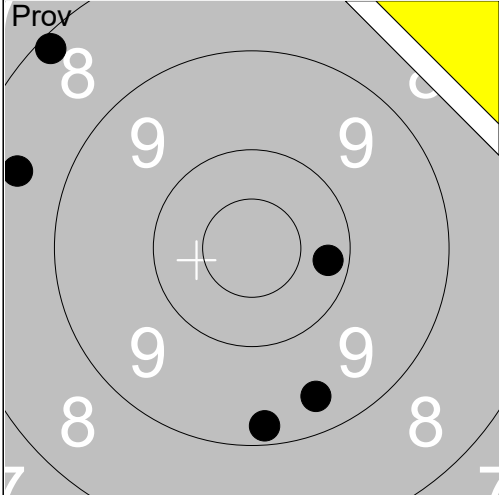

1:	8.2	↗
2:	10.2	→
3:	8.5	↖
4:	9.4	↓
5:	9.2	↓

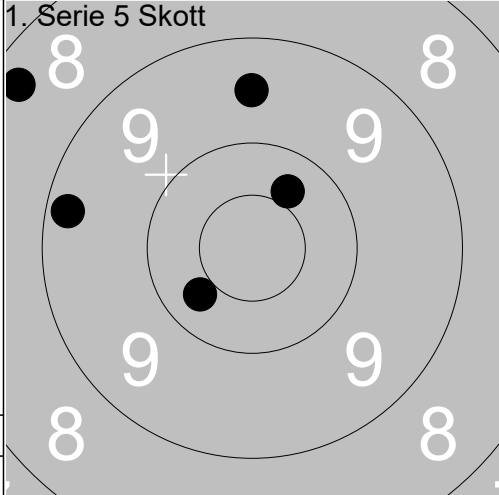

1:	9.5	↑
2:	8.3	↖
3:	10.4	↗
4:	9.2	←
5:	10.3	↙

Serie	44.0
Total	0.0

Serie	46.0
Total	46.0

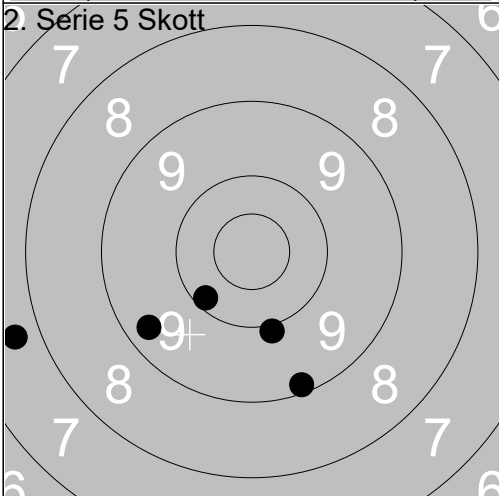

1:	10.1	↙
2:	7.7	←
3:	9.3	↙
4:	9.9	↓
5:	9.1	↓

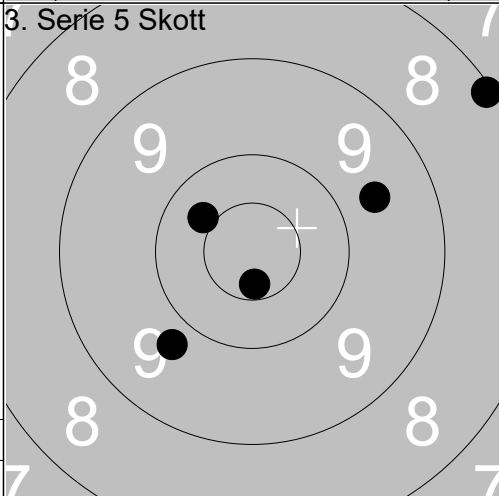

1:	8.1	↗
2:	9.6	↗
3:	10.6x	↓
4:	10.4	↖
5:	9.8	↙

Serie	44.0
Total	90.0

Serie	46.0
Total	136.0

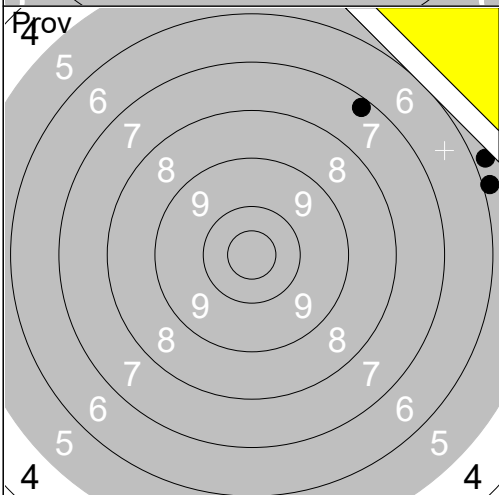

1:	5.9	→
2:	7.2	↗
3:	5.8	→

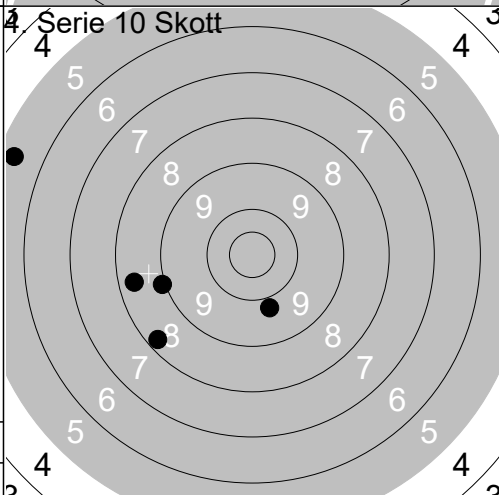

1:	9.8	↓
2:	8.4	←
3:	9.0	←
4:	8.2	↙
5:	5.4	↖

Serie	17.0
Total	136.0

Serie	39.0
Total	175.0

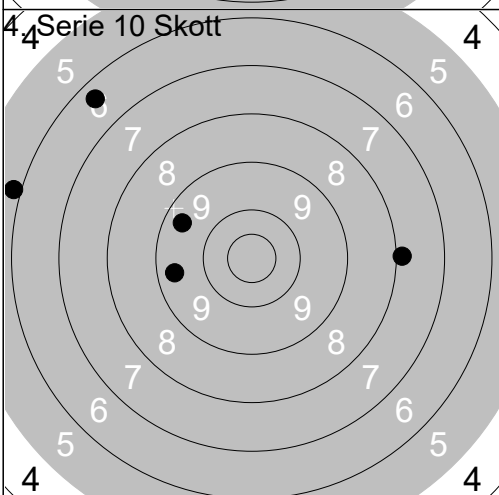

6:	7.9	→
7:	6.4	↗
8:	9.4	←
9:	5.9	←
10:	9.4	↗

Serie	36.0
Total	211.0