

Skjutlag <b>1</b>	Tavla <b>11</b>	<b>Josefin Utsi Hæggrud</b>		
Ramselefors		Gällivare	7	No
03.11.2019		Vindelnskyttet 2019	Ramselefors SKF	
<b>Prov</b> 	1: 10.5x ↓	<b>40 Skott</b> 	1: 10.6x ←	
	2: 10.6x ↑		2: 10.7x ↙	
	3: 10.8x ↑		3: 10.6x ↖	
	4: 10.4x ←		4: 10.4x ↙	
	5: 10.3x ↖		5: 10.5x →	
	6: 10.2x ↖		6: 10.7x ↗	
	7: 10.2x ↓		7: 10.5x ↙	
	8: 10.2x ←		8: 10.3x ←	
	9: 10.5x ←		9: 10.2x ↘	
	10: 10.5x →		10: 9.8 →	
	Serie 100		Serie 99	
	Total 0		Total 99	
<b>40 Skott</b> 	11: 10.4x ↑	<b>40 Skott</b> 	21: 10.3x →	
	12: 10.4x →		22: 10.5x ↓	
	13: 10.5x ↗		23: 10.6x ↖	
	14: 9.7 ←		24: 10.5x ↙	
	15: 10.1 ←		25: 10.6x ↓	
	16: 9.5 ↗		26: 10.4x ↘	
	17: 10.8x ↑		27: 10.7x ↑	
	18: 10.8x ←		28: 10.5x ↖	
	19: 10.4x →		29: 10.5x ↙	
	20: 9.9 →		30: 10.8x ↘	
	Serie 97		Serie 100	
	Total 196		Total 296	
<b>40 Skott</b> 	31: 10.2x ↙			
	32: 10.7x ↖			
	33: 10.2x ↖			
	34: 10.5x ↖			
	35: 10.7x →			
	36: 10.4x ↗			
	37: 10.4x ↘			
	38: 9.9 ↑			
	39: 10.1 ↑			
	40: 10.7x ←			
	Serie 99			
	Total 395			

Skjutlag <b>1</b>	Tavla <b>12</b>	<b>Theo Frölander</b>	
Ramselefors	Vännäs	7	Vb
03.11.2019	Vindelnskyttet 2019	Ramselefors SKF	
<b>Prov</b> 	1: 8.8 ↙ 2: 8.1 → 3: 7.8 ↓ 4: 8.9 ↓ 5: 9.5 → 6: 7.5 ↙ 7: 9.5 ↓ 8: 7.9 ↓ 9: 7.9 → <b>Serie 70</b> <b>Total 0</b>	<b>40 Skott</b> 	1: 7.2 ← 2: 9.4 ↓ 3: 9.6 ↗ 4: 9.7 ↑ 5: 8.7 ↗ 6: 8.7 ← 7: 5.2 ← 8: 6.8 ← 9: 10.7x ↗ 10: 10.6x ↙ <b>Serie 81</b> <b>Total 81</b>
<b>40 Skott</b> 	11: 8.3 ← 12: 9.7 ↙ 13: 10.3x → 14: 9.7 ↓ 15: 10.2x ↘ 16: 8.2 ↘ 17: 10.1 → 18: 7.7 ↓ 19: 9.3 ← 20: 9.2 ↓ <b>Serie 89</b> <b>Total 170</b>	<b>40 Skott</b> 	21: 9.6 ← 22: 10.5x ↓ 23: 9.3 → 24: 9.6 ↓ 25: 8.6 ↗ 26: 7.0 ← 27: 8.0 ← 28: 10.3x → 29: 8.0 ↗ 30: 10.1 ↓ <b>Serie 88</b> <b>Total 258</b>
<b>40 Skott</b> 	31: 10.5x ↗ 32: 9.6 ↑ 33: 10.4x ↓ 34: 10.3x ↖ 35: 10.2x ↖ 36: 10.3x ↓ 37: 10.4x ↙ 38: 10.5x ↓ 39: 10.2x ↙ 40: 10.5x ← <b>Serie 99</b> <b>Total 357</b>		

Skjuttag	Tavla	Michelle Lind		
1	13	Ramselefors	Drängsmark	7
03.11.2019	Vindelnskytten 2019	Ramselefors SKF		
	1: 10.0 ↓ 2: 9.7 ← 3: 10.0 ↓ 4: 10.2x → 5: 9.9 → 6: 7.4 → 7: 8.6 → 8: 8.9 → 9: 8.6 ↓ 10: 8.7 ←		11: 9.9 ↗	
Serie	87	Serie	9	
Total	0	Total	0	
	1: 9.8 ↗ 2: 10.0 ↓ 3: 10.2x ↓ 4: 9.5 ↗ 5: 10.3x ↓ 6: 9.3 ↗ 7: 8.4 ↓ 8: 10.0 ← 9: 7.8 → 10: 8.9 →		11: 10.8x ← 12: 10.2x ← 13: 9.0 ← 14: 8.6 ↓ 15: 9.4 ↗ 16: 9.1 ← 17: 8.3 ← 18: 9.8 → 19: 9.9 ↗ 20: 9.0 ↓	
Serie	90	Serie	90	
Total	90	Total	180	
	21: 9.4 ↗ 22: 10.2x → 23: 8.3 ← 24: 9.9 → 25: 8.8 ↗ 26: 8.3 → 27: 9.2 ↗ 28: 8.5 → 29: 9.6 → 30: 9.8 →		31: 10.4x ↘ 32: 9.8 ↘ 33: 8.7 ↗ 34: 10.1 ↗ 35: 9.7 ↘ 36: 9.7 ↘ 37: 7.9 ↗ 38: 10.0 ↗ 39: 9.3 ↘ 40: 9.6 ←	
Serie	87	Serie	90	
Total	267	Total	357	

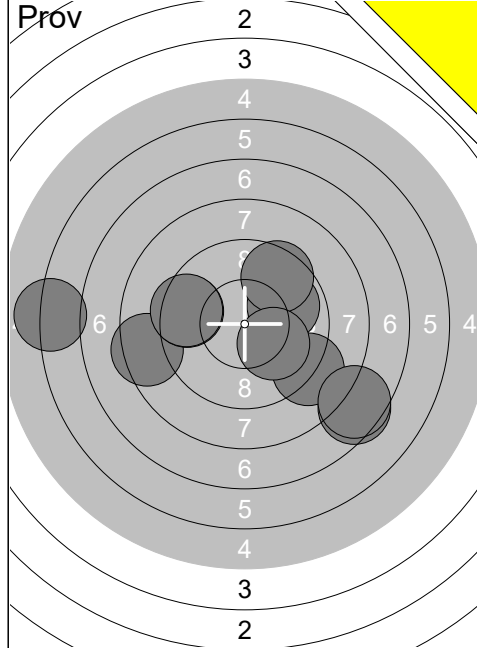

1:	6.1	←
2:	8.4	←
3:	7.5	↘
4:	9.0	↘
5:	7.6	↘
6:	9.9	↗
7:	9.5	↗
8:	10.1	↘
9:	9.5	←
10:	9.5	←
Serie		83
Total		0

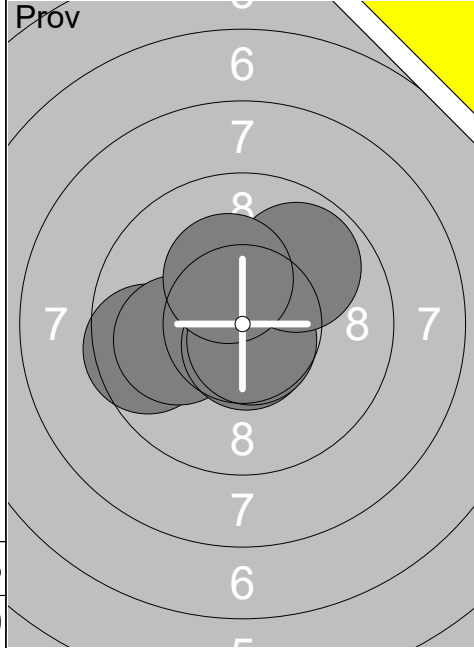

11:	9.6	←
12:	10.0	←
13:	10.7x	↓
14:	10.7x	↓
15:	9.9	↗
16:	10.3x	↗
Serie		58
Total		0

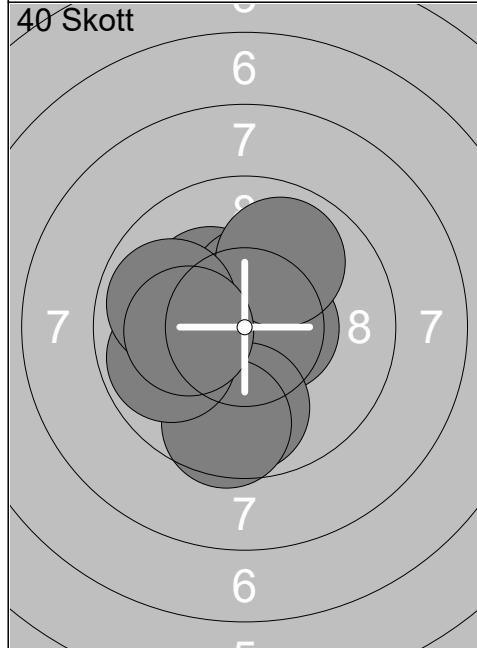

1:	10.3x	↖
2:	10.4x	↗
3:	10.1	←
4:	10.5x	→
5:	9.9	↗
6:	9.8	↓
7:	9.6	↓
8:	9.8	←
9:	9.9	←
10:	10.2x	←
Serie		95
Total		95

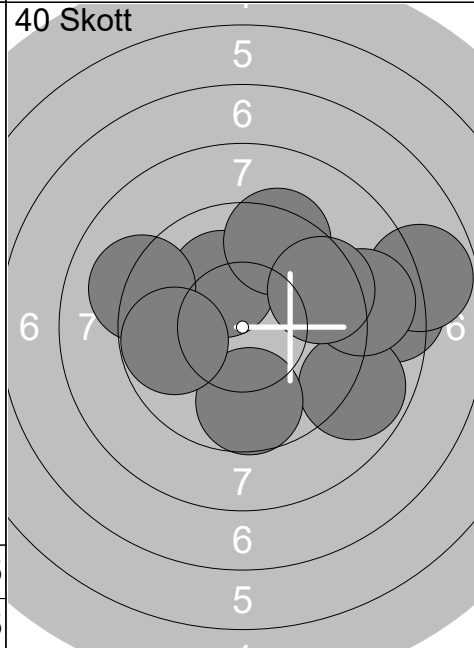

11:	8.4	→
12:	10.2x	↖
13:	9.4	↗
14:	7.9	→
15:	8.8	↘
16:	8.9	→
17:	9.5	↗
18:	9.1	←
19:	9.7	↓
20:	9.8	←
Serie		86
Total		181

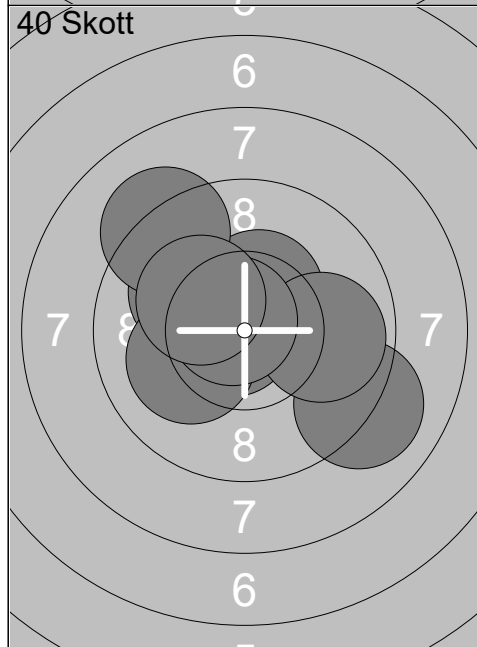

21:	10.1	↖
22:	10.3x	←
23:	10.8x	←
24:	10.1	←
25:	10.4x	↗
26:	9.1	↘
27:	9.9	→
28:	10.7x	↖
29:	9.2	↗
30:	10.2x	↖
Serie		97
Total		278

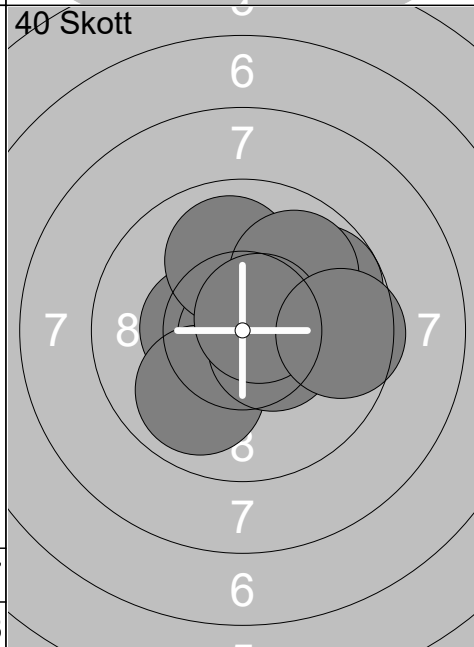

31:	10.3x	→
32:	10.4x	←
33:	10.9x	↓
34:	10.0	↑
35:	9.8	↗
36:	9.9	↗
37:	9.9	↓
38:	10.5x	↘
39:	10.7x	↗
40:	9.6	→
Serie		96
Total		374

Skjutlag	Tavla	Samuel Österlund		
1	15	Ramselefors	7	Vb
03.11.2019	Vindelnskyttet 2019	Ramselefors SKF		
<b>Prov</b> 	1: 7.7 → 2: 9.3 ↙ 3: 9.4 ↘ 4: 8.7 ↓ 5: 9.5 ← 6: 9.4 → 7: 9.0 ↓ 8: 10.1 ↓ 9: 9.4 ↗ 10: 9.4 ↗ Serie 88 Total 0	<b>Prov</b> 	11: 10.9x → 12: 9.6 ↘ 13: 8.9 ↗ 14: 10.6x ↙ Serie 37 Total 0	
<b>40 Skott</b> 	1: 10.0 ← 2: 10.7x ↙ 3: 9.3 ← 4: 9.8 ↑ 5: 10.5x ↑ 6: 9.8 ↗ 7: 9.4 ↘ 8: 10.6x ↙ 9: 9.3 ↓ 10: 8.7 → Serie 93 Total 93	<b>40 Skott</b> 	11: 10.3x ↗ 12: 10.5x ↘ 13: 10.3x ↘ 14: 10.1 ↗ 15: 9.8 ↗ 16: 10.2x → 17: 10.3x ↘ 18: 9.1 ↘ 19: 10.5x ↙ 20: 10.5x → Serie 98 Total 191	
<b>40 Skott</b> 	21: 8.8 → 22: 9.2 → 23: 7.4 ↘ 24: 10.8x ↗ 25: 10.5x ↗ 26: 7.7 ↓ 27: 9.9 → 28: 10.5x ↙ 29: 8.5 ↘ 30: 7.8 ↗ Serie 85 Total 276	<b>40 Skott</b> 	31: 9.8 ↘ 32: 7.2 ↘ 33: 9.9 ← 34: 9.5 → 35: 7.2 → 36: 10.2x ↘ 37: 9.7 → 38: 9.9 ← 39: 10.1 ↓ 40: 9.3 ↘ Serie 88 Total 364	



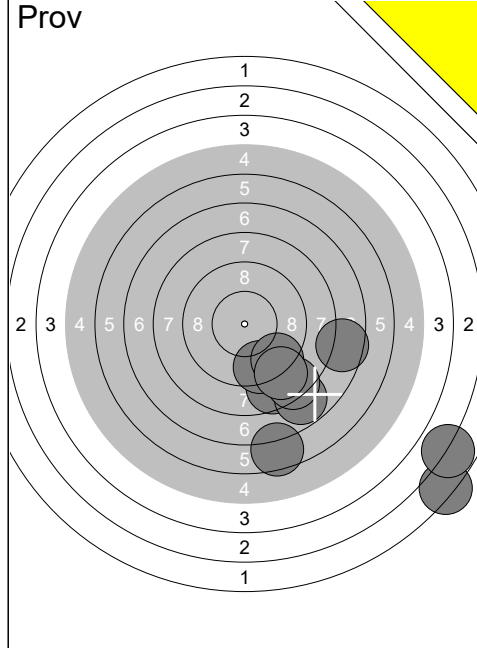

1:	2.1	↘
2:	2.8	↘
3:	8.6	↘
4:	7.8	↘
5:	6.5	↘
6:	9.4	↘
7:	9.3	↘
8:	8.4	↘
9:	7.6	→
10:	8.9	↘
Serie		66
Total		0

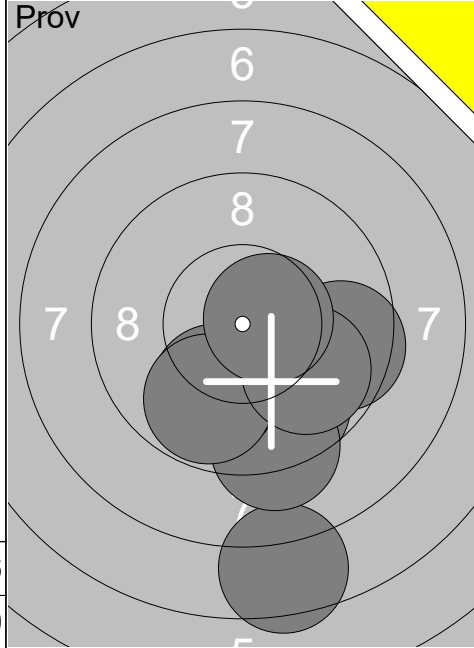

11:	9.7	↘
12:	7.5	↘
13:	9.2	↘
14:	10.0	↘
15:	9.5	→
16:	9.8	↘
17:	9.9	↘
18:	10.6x	→
Serie		72
Total		0

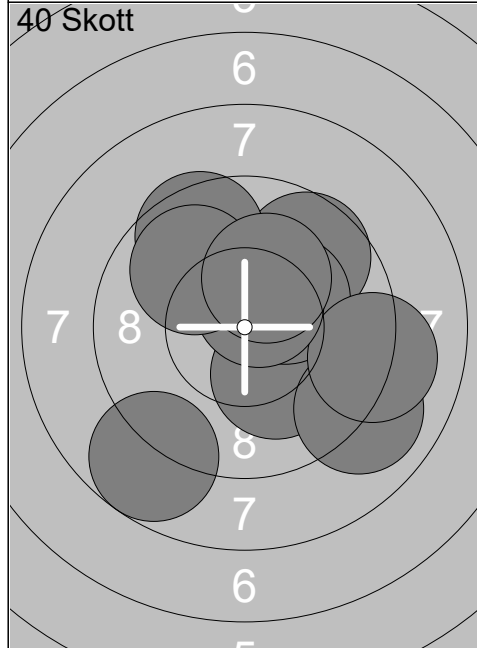

1:	10.2x	↘
2:	9.7	↗
3:	10.3x	↗
4:	8.8	↘
5:	9.0	↘
6:	9.5	↗
7:	9.1	→
8:	10.5x	↗
9:	9.9	↗
10:	10.2x	↗
Serie		93
Total		93

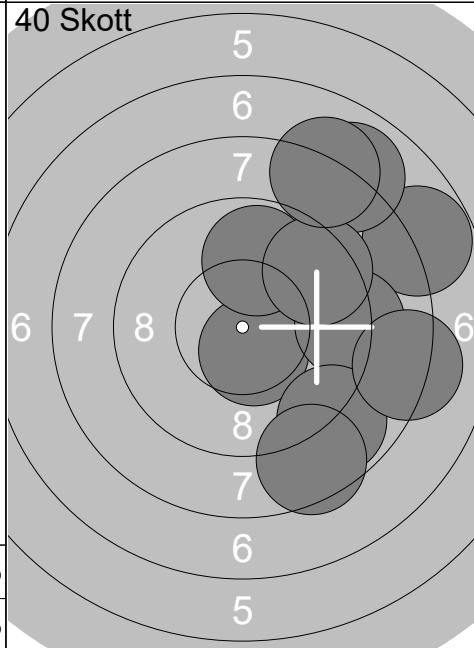

11:	10.5x	↘
12:	7.8	↗
13:	9.2	→
14:	8.9	↘
15:	8.2	→
16:	8.0	↗
17:	9.8	↗
18:	8.5	↘
19:	9.4	↗
20:	8.1	↗
Serie		84
Total		177

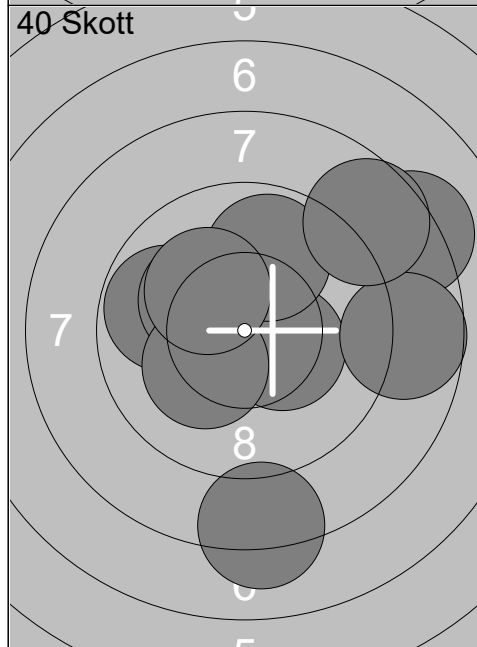

21:	9.8	←
22:	10.4x	→
23:	9.9	↗
24:	8.2	↘
25:	10.2x	↖
26:	10.2x	↖
27:	8.2	↗
28:	8.7	→
29:	10.2x	↖
30:	8.6	↗
Serie		90
Total		267

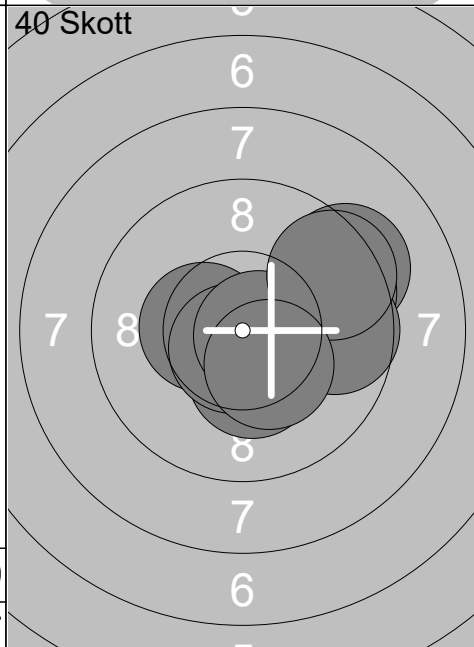



31:	9.3	↗
32:	10.4x	←
33:	10.3x	↘
34:	9.6	↗
35:	10.7x	↘
36:	10.7x	↘
37:	9.7	→
38:	10.7x	→
39:	9.5	↗
40:	10.4x	↘
Serie		96
Total		363

Skjutlag	Tavla	Alice Sandström		
1	19	Ramselefors	Vännäs	9
03.11.2019		Vindelnskytten 2019		Ramselefors SKF
	1: 8.0 ↓		11: 9.8 ↗	
	2: 9.3 ←		12: 9.8 ↓	
	3: 8.1 ↓		13: 10.0 ↖	
	4: 9.4 ←			
	5: 9.2 ↓			
	6: 5.4 →			
	7: 7.1 →			
	8: 9.7 ↑			
	9: 9.2 →			
	10: 8.4 →			
Serie	81	Serie	28	
Total	0	Total	0	
	1: 8.0 →		11: 9.1 ←	
	2: 10.1 →		12: 7.8 ↓	
	3: 8.2 →		13: 9.8 →	
	4: 10.1 ↑		14: 8.3 ←	
	5: 8.8 →		15: 10.0 ←	
	6: 9.6 ↑		16: 10.1 →	
	7: 9.1 →		17: 7.4 ↗	
	8: 9.7 →		18: 9.9 ←	
	9: 10.5x →		19: 9.9 ↑	
	10: 8.0 ↗		20: 8.7 ↖	
Serie	89	Serie	86	
Total	89	Total	175	
	21: 10.2x ↑		31: 8.5 ↓	
	22: 9.4 ←		32: 9.7 ↓	
	23: 10.3x ←		33: 8.5 ←	
	24: 10.2x ↑		34: 8.1 →	
	25: 8.4 ↑		35: 10.1 ↑	
	26: 9.6 ↖		36: 9.2 ↗	
	27: 9.4 →		37: 7.3 →	
	28: 9.7 ↓		38: 10.1 ↖	
	29: 4.3 ↓		39: 10.2x ↖	
	30: 9.9 ↖		40: 8.8 →	
Serie	87	Serie	87	
Total	262	Total	349	

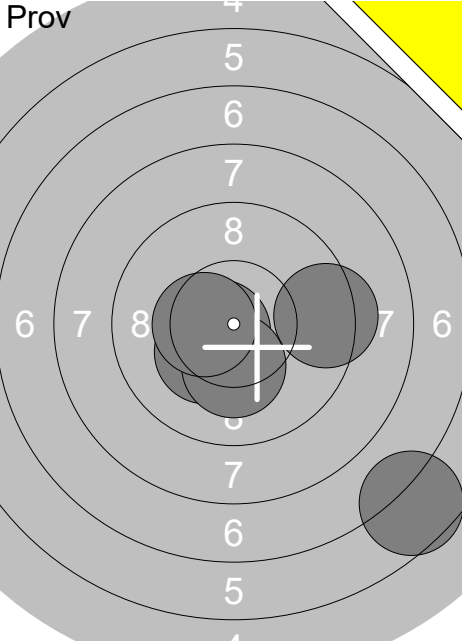
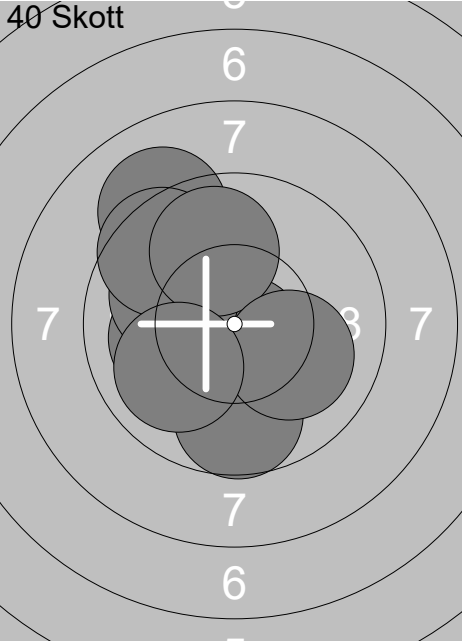
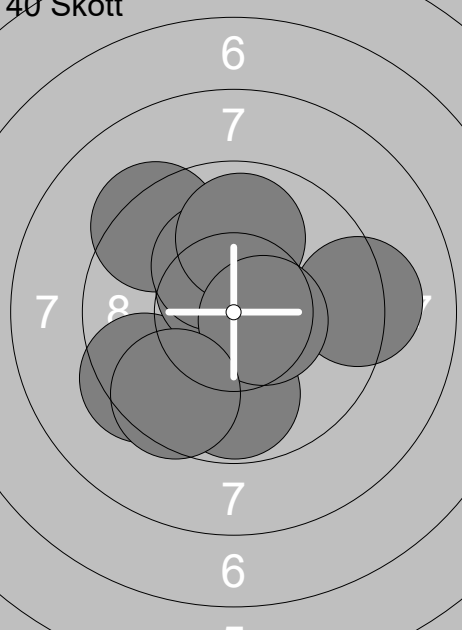

Skjuttag	Tavla	Liv Nilsson	
1	20	Ramselefors	Rönnskär
03.11.2019	Vindelnskyttet 2019	9	Vb
03.11.2019	Vindelnskyttet 2019	Ramselefors SKF	
<b>Prov</b> 	1: 10.1 → 2: 9.1 ↘ 3: 10.3x ↘ 4: 9.9 ↗ 5: 8.9 ↗ 6: 9.9 → 7: 10.2x ↗ 8: 8.8 → 9: 9.2 ← 10: 9.8 ↘ Serie 91 Total 0	<b>Prov</b> 	11: 10.7x ↗ 12: 9.8 → 13: 10.2x ↗ 14: 9.4 ↗ 15: 10.7x ↘ 16: 10.6x ↘ 17: 10.2x ← Serie 68 Total 0
<b>40 Skott</b> 	1: 8.4 → 2: 10.0 ↖ 3: 9.1 → 4: 10.1 → 5: 9.8 ← 6: 10.6x → 7: 10.1 → 8: 10.2x → 9: 10.5x ↖ 10: 10.0 ↘ Serie 96 Total 96	<b>40 Skott</b> 	11: 9.5 → 12: 10.0 ↓ 13: 10.6x ← 14: 9.0 ↘ 15: 8.9 → 16: 10.2x ↘ 17: 8.4 → 18: 10.5x → 19: 9.5 ↗ 20: 10.0 ← Serie 93 Total 189
<b>40 Skott</b> 	21: 10.3x → 22: 9.4 → 23: 9.5 ↗ 24: 10.7x ↘ 25: 10.3x ↘ 26: 8.1 → 27: 9.8 → 28: 10.5x ↗ 29: 10.7x ↗ 30: 9.9 ← Serie 94 Total 283	<b>40 Skott</b> 	31: 9.8 ← 32: 9.7 ↗ 33: 10.2x ↗ 34: 10.2x ↗ 35: 10.5x ↖ 36: 10.1 → 37: 9.5 ↗ 38: 9.8 → 39: 10.5x ← 40: 9.6 ↘ Serie 95 Total 378

Skjuttag	Tavla	Tore Tiburzi		
1	21	Ramselefors	Drängsmark	9
03.11.2019	Vindelnskyttet 2019	Ramselefors SKF		
<b>Prov</b> 	1: 10.0 ↗ 2: 8.4 ↗ 3: 10.4x → 4: 10.3x ↖ 5: 10.6x ↖ 6: 10.1 ← 7: 9.9 ↗ 8: 9.9 ↗ 9: 9.8 ↗ 10: 9.6 →	<b>Prov</b> 	11: 9.5 ↗ 12: 9.4 ↗ 13: 9.9 ↗ 14: 8.9 ← 15: 10.3x ↑	
Serie 94	Total 0	Serie 45	Total 0	
<b>40 Skott</b> 	1: 10.0 ↖ 2: 10.3x ← 3: 9.1 ← 4: 9.7 ↘ 5: 9.6 ↗ 6: 9.2 ↗ 7: 8.7 → 8: 10.5x ↘ 9: 10.1 ↗ 10: 10.4x ↖	<b>40 Skott</b> 	11: 9.9 ↑ 12: 10.6x ↗ 13: 10.2x ↗ 14: 10.1 ↖ 15: 10.1 ↑ 16: 10.8x ↖ 17: 9.8 ↘ 18: 9.9 ↑ 19: 10.6x ↑ 20: 9.2 ↗	
Serie 94	Total 94	Serie 96	Total 190	
<b>40 Skott</b> 	21: 10.1 ↓ 22: 10.2x → 23: 10.4x → 24: 8.9 ↗ 25: 9.4 ↑ 26: 8.5 ↗ 27: 9.6 ↗ 28: 9.7 ↗ 29: 10.0 ← 30: 8.4 ↑	<b>40 Skott</b> 	31: 9.4 ↗ 32: 8.9 ↗ 33: 10.0 ↑ 34: 10.3x ← 35: 10.3x ↖ 36: 10.7x ↖ 37: 10.8x ↑ 38: 9.5 → 39: 10.8x → 40: 9.6 ↗	
Serie 91	Total 281	Serie 95	Total 376	

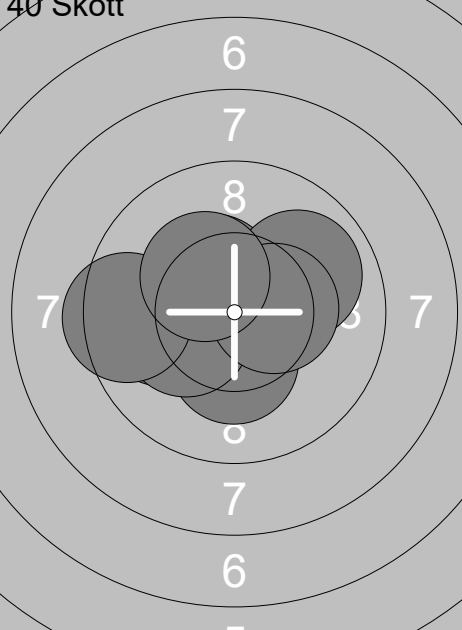
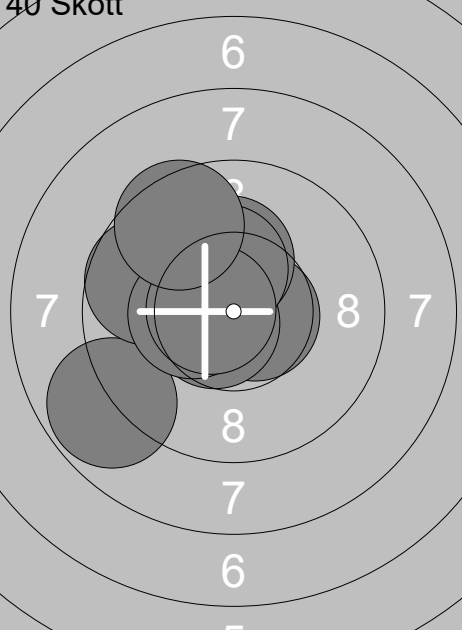
Skjutlag <b>1</b>	Tavla <b>22</b>	<b>Dennis Alenius</b>			
Ramselefors	Ramselefors	9	Vb		
03.11.2019	Vindelnskyttet 2019	Ramselefors SKF			
Prov		1: 10.3x ↙ 2: 9.4 → 3: 6.6 ↘ 4: 10.7x ↙ 5: 10.2x ↓ 6: 10.4x ↙ Serie 55 Total 0	40 Skott		1: 10.0 ↗ 2: 9.1 ↗ 3: 10.1 ← 4: 10.7x ↓ 5: 10.0 ↖ 6: 9.5 ↗ 7: 9.9 ↑ 8: 9.7 ↓ 9: 10.1 ↘ 10: 10.0 ↙ Serie 96 Total 96
40 Skott		11:  12: 9.2 → 13: 9.4 ↙ 14: 9.8 ↓ 15: 9.3 ↗ 16: 10.5x ↗ 17: 10.3x ↗ 18: 9.9 ↑ 19: 10.5x → 20: 9.6 ↘ Serie 84 Total 180	40 Skott		21: 10.4x ↗ 22: 10.6x ↗ 23: 10.4x ↙ 24: 9.9 ↗ 25: 10.3x ↓ 26: 10.0 ← 27: 10.2x ↙ 28: 9.5 ← 29: 10.4x → 30: 10.3x ↗ Serie 98 Total 278
40 Skott		31: 10.2x ↙ 32: 10.7x → 33: 10.2x ↑ 34: 8.8 ↙ 35: 10.6x ↙ 36: 9.7 ↖ 37: 10.4x ↙ 38: 10.3x ↑ 39: 10.6x ↙ 40: 9.5 ↗ Serie 96 Total 374			

Skjutlag <b>1</b>	Tavla <b>23</b>	<b>Erika Gustafsson</b>	
Ramselefors	Ramselefors	9	Vb
03.11.2019	Vindelnskyttet 2019	Ramselefors SKF	
<b>Prov</b> 	1: 10.7x ↗ 2: 10.6x ↘ 3: 9.9 ↗ 4: 10.5x ↑ 5: 10.3x ↗ 6: 9.4 → 7: 10.7x ↖ 8: 10.5x → 9: 10.7x ↖ 10: 10.4x ←	<b>40 Skott</b> 	1: 10.4x ↘ 2: 10.6x ↘ 3: 10.6x ↗ 4: 10.9x ↘ 5: 10.7x ↘ 6: 10.4x ↘ 7: 10.5x ↗ 8: 10.4x ← 9: 10.5x ↘ 10: 10.0 ←
	Serie 98		Serie 100
	Total 0		Total 100
<b>40 Skott</b> 	11: 10.6x ↘ 12: 10.5x ← 13: 10.4x ← 14: 10.4x ↘ 15: 10.4x ↘ 16: 10.6x ↘ 17: 10.3x ↗ 18: 10.1 ← 19: 10.4x ↑ 20: 9.9 ↓	<b>40 Skott</b> 	21: 10.9x → 22: 10.2x ↘ 23: 10.0 ↓ 24: 10.2x ← 25: 10.7x → 26: 10.3x ← 27: 10.6x ↘ 28: 10.2x ↗ 29: 10.4x ↘ 30: 10.6x ↘
	Serie 99		Serie 100
	Total 199		Total 299
<b>40 Skott</b> 	31: 10.0 ← 32: 10.7x ← 33: 10.4x → 34: 10.7x ↘ 35: 9.8 ↗ 36: 10.3x ↘ 37: 10.7x ↗ 38: 10.3x ↘ 39: 10.1 → 40: 10.8x ↘		
	Serie 99		
	Total 398		

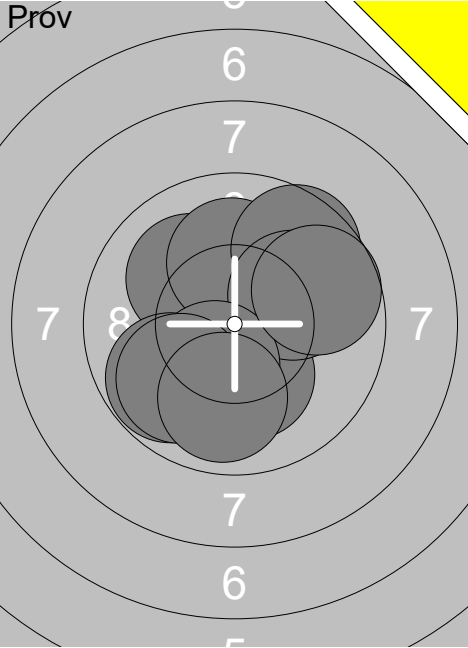
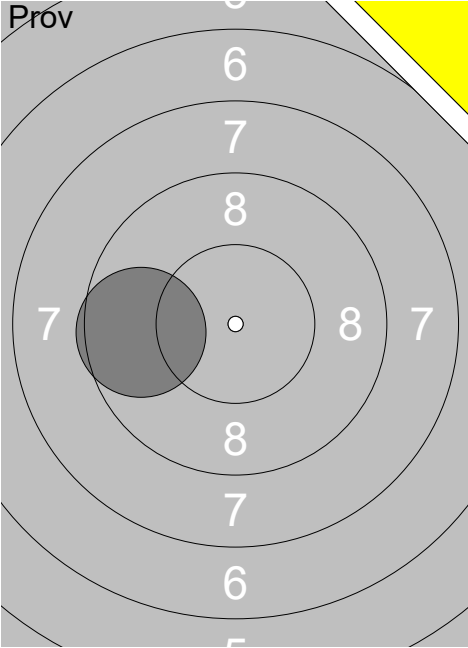
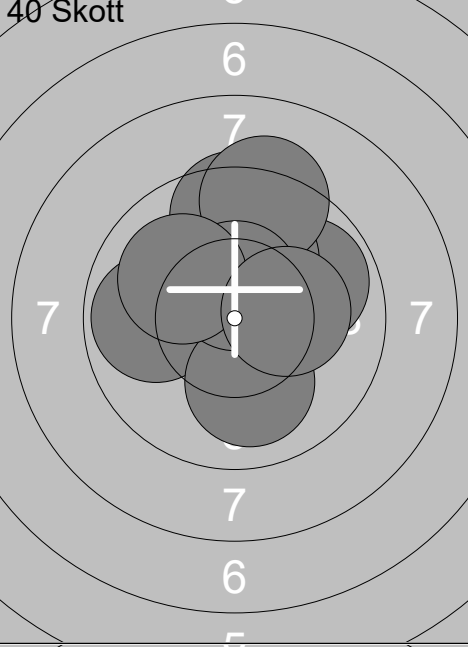
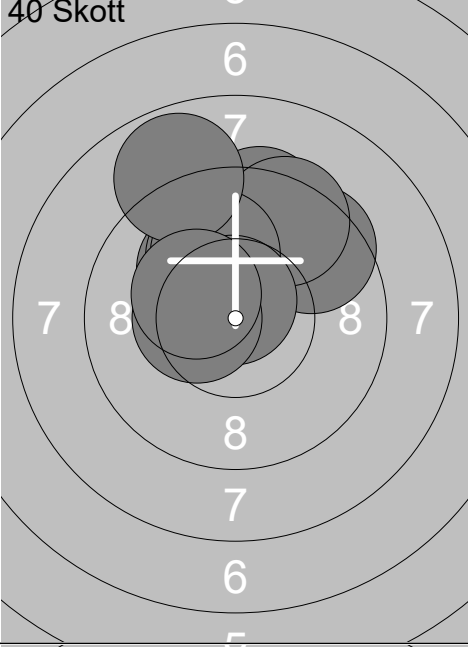
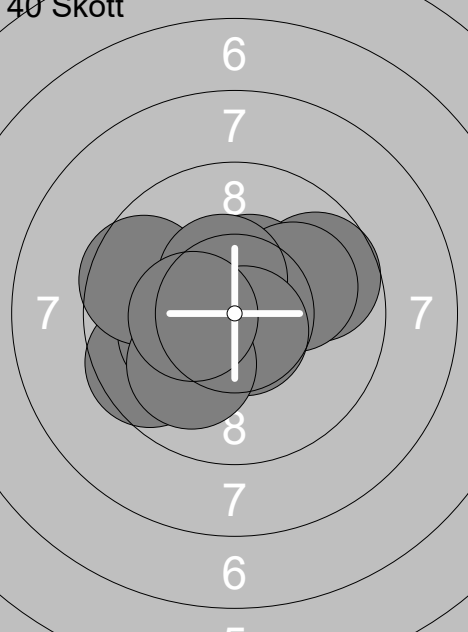
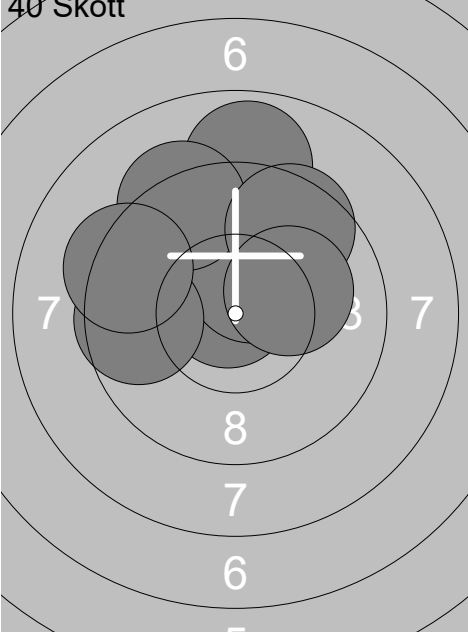
Skjutlag	Tavla	Emil Holmlund		
1	24	Umeå	9	Vb
03.11.2019	Vindelnskyttet 2019	Ramselefors SKF		
<b>Prov</b> 	1: 10.1 ↖ 2: 10.2x ↓ 3: 10.1 ↑ 4: 9.8 ↙ 5: 9.6 ↗ 6: 10.0 ↘ 7: 10.3x ↓ 8: 9.9 ↙ 9: 9.7 ↘ 10: 9.9 ↓ Serie 95 Total 0	<b>Prov</b> 	11: 9.6 ← Serie 9 Total 0	
<b>40 Skott</b> 	1: 10.3x ↙ 2: 9.9 ← 3: 9.9 ↘ 4: 10.1 ↑ 5: 9.5 ↑ 6: 9.3 ↑ 7: 10.0 ↓ 8: 10.5x ↑ 9: 10.0 ↖ 10: 10.2x → Serie 96 Total 96	<b>40 Skott</b> 	11: 9.5 ↗ 12: 9.4 ↑ 13: 9.4 ↗ 14: 10.1 ↖ 15: 10.0 ↑ 16: 10.0 ↑ 17: 10.7x ↑ 18: 8.9 ↑ 19: 10.4x ← 20: 10.3x ↙ Serie 95 Total 191	
<b>40 Skott</b> 	21: 9.6 ↙ 22: 10.2x ← 23: 9.7 ↘ 24: 10.4x ↑ 25: 9.6 ← 26: 10.1 ↘ 27: 10.5x ↑ 28: 10.7x ↓ 29: 10.0 ↓ 30: 10.4x ← Serie 97 Total 288	<b>40 Skott</b> 	31: 10.1 ↑ 32: 9.4 ↑ 33: 8.9 ↑ 34: 10.8x ↖ 35: 10.4x ↗ 36: 9.3 ↖ 37: 9.6 ↗ 38: 9.6 ← 39: 9.3 ↖ 40: 10.1 ↘ Serie 93 Total 381	

Skjutlag <b>1</b>	Tavla <b>25</b>	<b>Robin Alfredsson</b>		
Ramselefors		Umeå	9	Vb
03.11.2019		Vindelnskyttet 2019	Ramselefors SKF	
<b>Prov</b> 	1: 10.1 ↖ 2: 10.5x ← 3: 8.8 ↑ 4: 9.6 ↖ 5: 8.9 ← 6: 10.1 ↘ 7: 10.4x ↗ 8: 9.9 ↗ 9: 10.2x → 10: 9.3 ↑ Serie 93 Total 0	<b>Prov</b> 	11: 9.8 ↖ 12: 9.9 ↑ 13: 9.8 ↗ 14: 10.5x ↓ 15: 9.6 ↗ 16: 10.1 ↗ 17: 9.7 ↓ 18: 10.6x → 19: 10.2x ↑ 20: 10.2x ↑ Serie 95 Total 0	
<b>Prov</b> 	21: 9.8 ↑ 22: 10.6x ↓ Serie 19 Total 0	<b>40 Skott</b> 	1: 10.3x ↘ 2: 10.4x ↘ 3: 10.3x ← 4: 10.0 ↑ 5: 10.6x → 6: 9.8 ← 7: 10.4x ↑ 8: 10.1 ↓ 9: 10.5x ↑ 10: 9.5 ↘ Serie 98 Total 98	
<b>40 Skott</b> 	11: 10.7x ↘ 12: 10.8x ↘ 13: 9.9 ↖ 14: 10.0 ↗ 15: 10.7x ↘ 16: 10.7x ↘ 17: 10.4x ↗ 18: 10.7x ↗ 19: 10.4x ← 20: 10.8x ↘ Serie 99 Total 197	<b>40 Skott</b> 	21: 10.6x ↑ 22: 9.5 ↖ 23: 9.9 ← 24: 10.8x ↘ 25: 10.5x → 26: 10.3x ↖ 27: 10.0 ↗ 28: 9.8 ← 29: 10.0 ↘ 30: 9.7 ↖ Serie 96 Total 293	
<b>40 Skott</b> 	31: 10.3x ↘ 32: 9.3 ↑ 33: 10.7x ↗ 34: 9.8 ← 35: 10.8x ↑ 36: 10.3x ↘ 37: 10.1 ↓ 38: 10.7x ← 39: 9.8 ↗ 40: 10.0 ↑ Serie 97 Total 390			

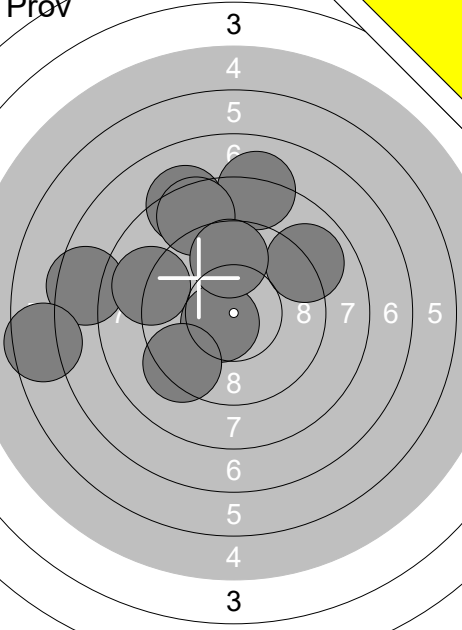
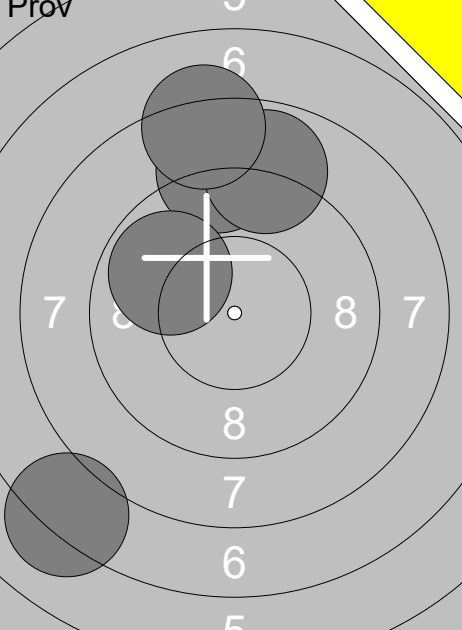
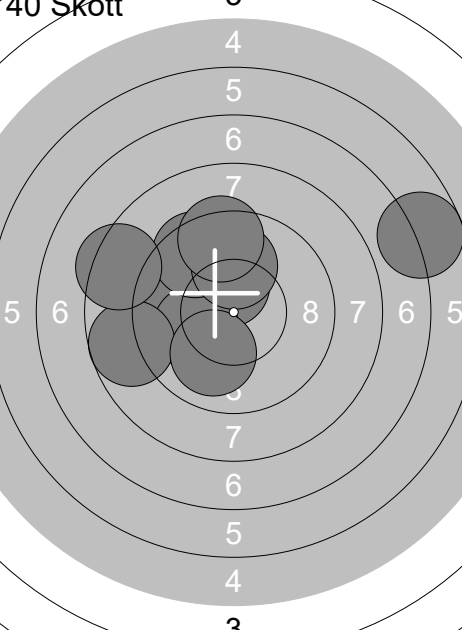
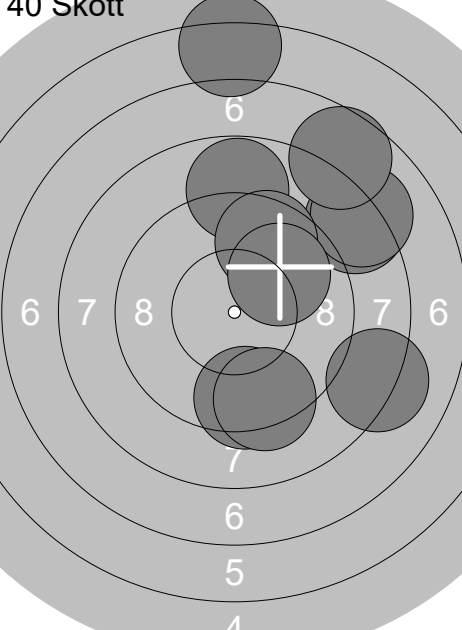
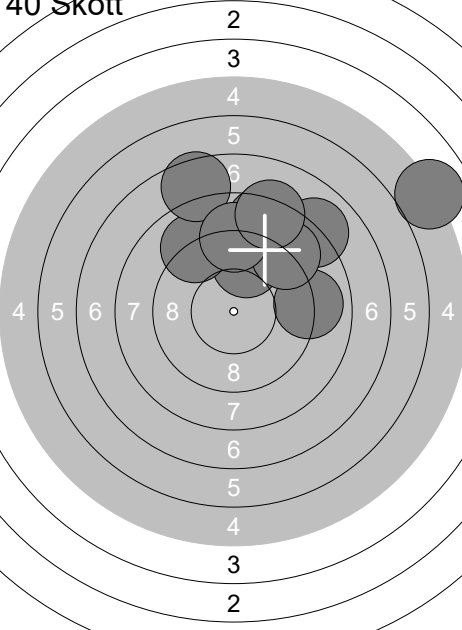
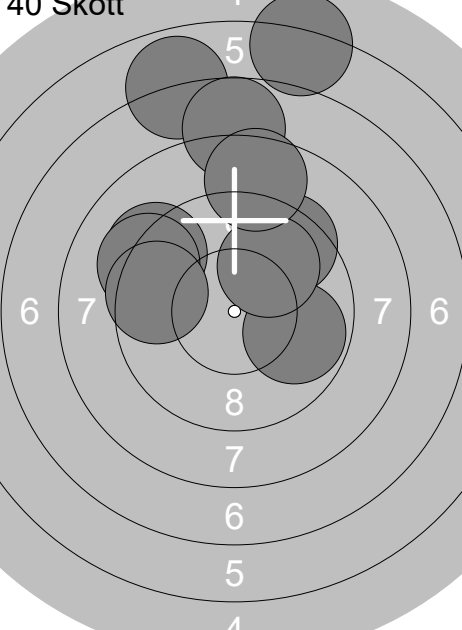
Skjuttag	Tavla	Vidar Sandström		
1	26	Ramselefors	Vännäs	11 Vb
03.11.2019	Vindelnskyttet 2019	Ramselefors SKF		
<b>Prov</b> 	1: 7.5 ← 2: 8.1 ↑ 3: 9.0 ← 4: 8.2 ↑ 5: 10.6x ↙ 6: 6.5 ← 7: 9.0 → 8: 9.3 ↙ 9: 8.6 ↑ 10: 9.7 ↑ Serie 83 Total 0	<b>Prov</b> 	11: 8.9 ↑ 12: 9.9 ↙ 13: 8.9 ↑ 14: 7.2 ↘ 15: 8.2 ↑ Serie 40 Total 0	
<b>40 Skott</b> 	1: 9.2 ← 2: 10.4x ↑ 3: 10.1 ← 4: 8.7 ← 5: 6.7 → 6: 9.5 ↘ 7: 10.0 ↘ 8: 10.0 ↑ 9: 8.4 ← 10: 9.4 ↑ Serie 89 Total 89	<b>40 Skott</b> 	11: 8.8 ↑ 12: 8.3 → 13: 8.1 → 14: 8.2 → 15: 6.2 ↑ 16: 9.6 ↑ 17: 9.4 ↓ 18: 9.3 ↓ 19: 7.7 ↗ 20: 9.9 ↗ Serie 81 Total 170	
<b>40 Skott</b> 	21: 8.5 ↑ 22: 9.6 ↑ 23: 5.0 → 24: 9.0 ↘ 25: 8.0 ↗ 26: 7.6 ↑ 27: 9.0 → 28: 8.9 ↗ 29: 9.0 ↑ 30: 8.3 ↑ Serie 80 Total 250	<b>40 Skott</b> 	31: 9.2 ↙ 32: 6.9 ↑ 33: 9.5 ↗ 34: 7.7 ↑ 35: 6.1 ↑ 36: 9.2 ↙ 37: 9.8 → 38: 10.0 ↗ 39: 8.6 ↑ 40: 9.5 ← Serie 82 Total 332	

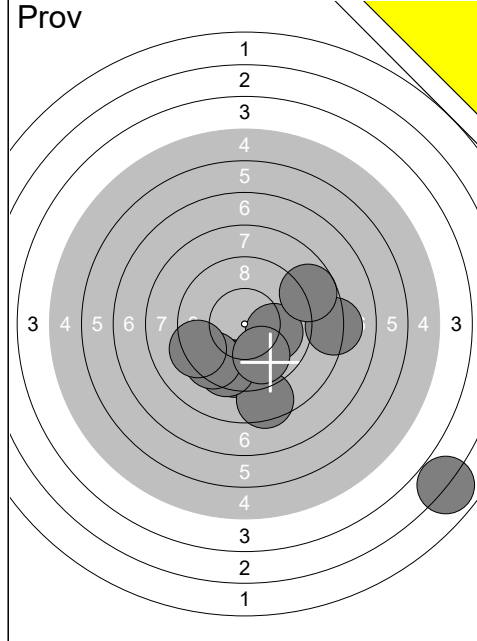

1:	2.9	↘
2:	9.5	↓
3:	10.0	→
4:	8.5	↓
5:	9.5	↓
6:	9.4	↙
7:	9.3	↙
8:	8.2	→
9:	9.9	↓
10:	8.7	→
<b>Serie</b>		<b>81</b>
<b>Total</b>		<b>0</b>

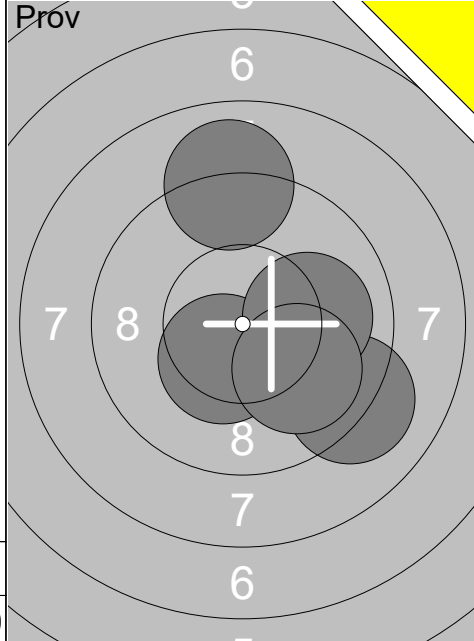

11:	10.4x	↘
12:	9.1	↘
13:	10.0	→
14:	10.0	↘
15:	9.0	↑
<b>Serie</b>		<b>48</b>
<b>Total</b>		<b>0</b>

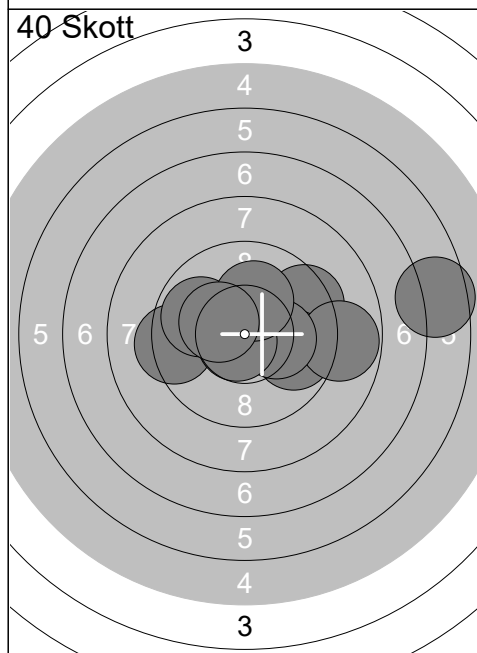

1:	9.3	←
2:	9.4	→
3:	9.8	→
4:	8.8	→
5:	6.6	→
6:	9.9	↙
7:	10.2x	→
8:	10.7x	↙
9:	10.2x	↑
10:	10.3x	↙
<b>Serie</b>		<b>90</b>
<b>Total</b>		<b>90</b>

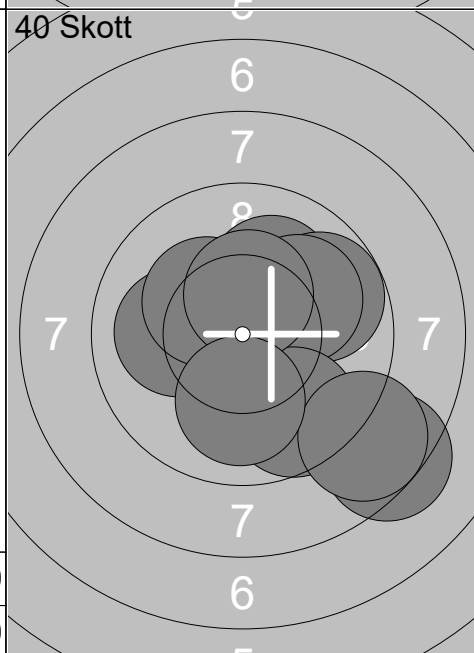

11:	8.3	↘
12:	10.1	↗
13:	9.8	→
14:	10.1	←
15:	10.0	↗
16:	9.7	↓
17:	10.3x	↖
18:	8.8	↘
19:	10.4x	↑
20:	10.0	↓
<b>Serie</b>		<b>94</b>
<b>Total</b>		<b>184</b>

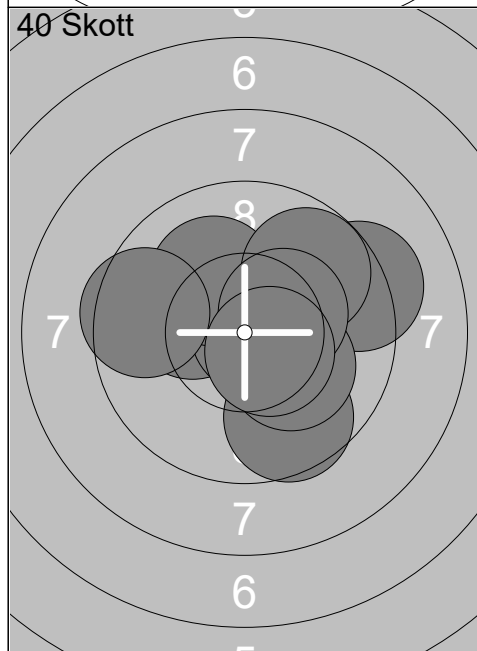

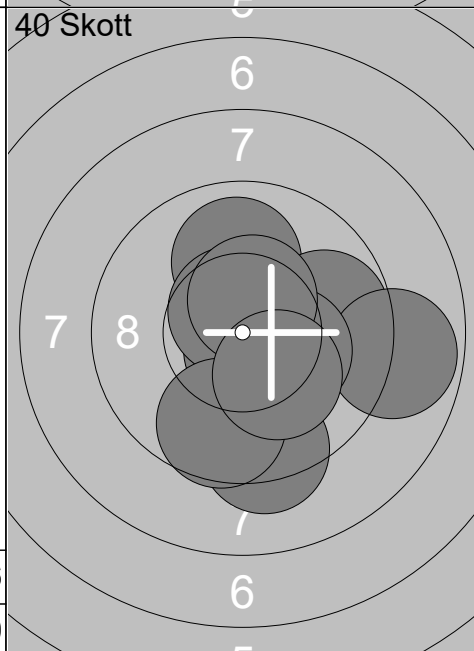

21:	10.2x	↙
22:	10.8x	→
23:	9.2	→
24:	10.1	↗
25:	9.6	↓
26:	9.8	↗
27:	10.2x	↘
28:	10.4x	→
29:	10.5x	↘
30:	9.5	←
<b>Serie</b>		<b>96</b>
<b>Total</b>		<b>280</b>





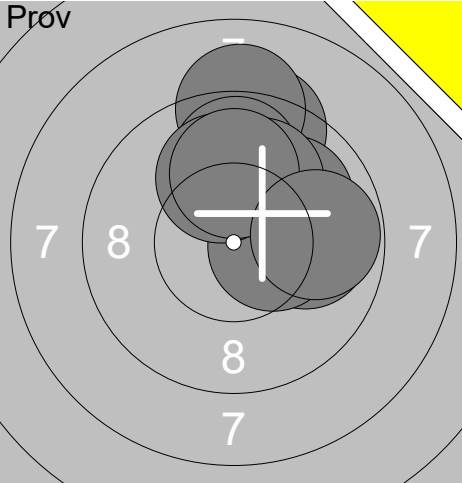
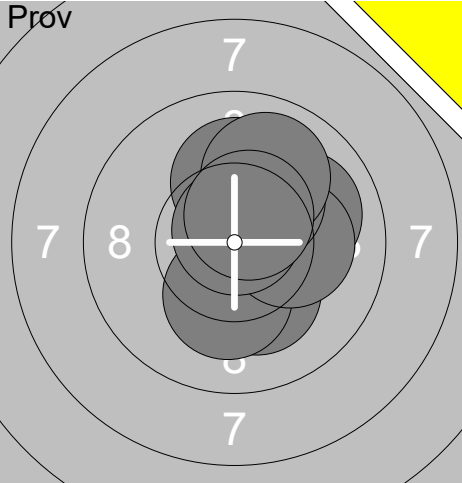

31:	10.0	↑
32:	9.8	→
33:	10.7x	↓
34:	8.9	→
35:	10.6x	↗
36:	9.3	↓
37:	10.3x	→
38:	9.7	↓
39:	10.5x	↑
40:	10.2x	↘
<b>Serie</b>		<b>95</b>
<b>Total</b>		<b>375</b>

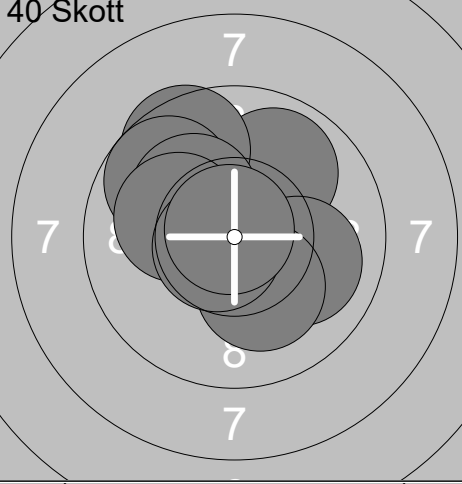
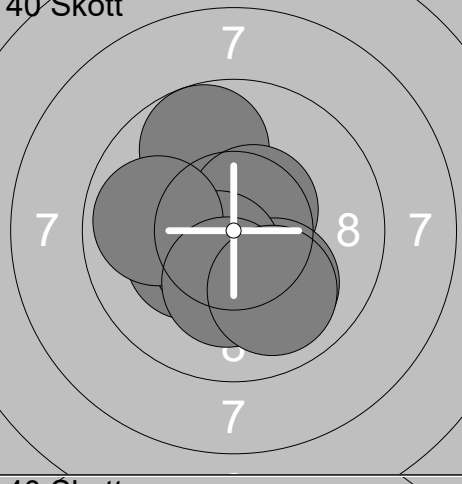
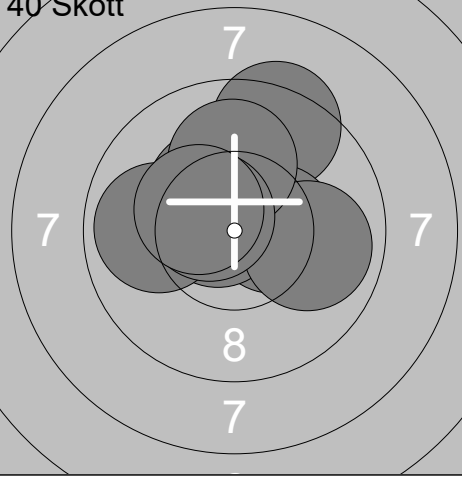
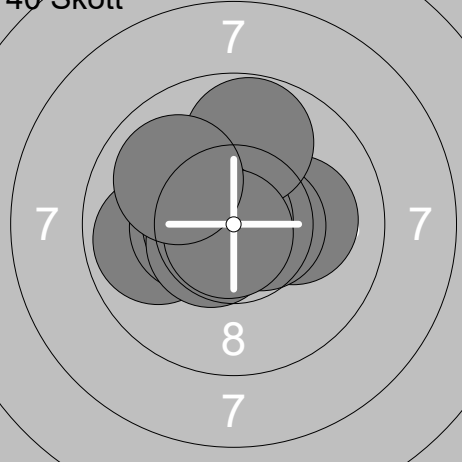

Skjuttag	Tavla	Albin Thorstensson		
1	28	Ramselefors	11	Vb
03.11.2019	Vindelnskyttet 2019	Ramselefors SKF		
<b>Prov</b> 	1: 8.5 ↗ 2: 10.4x → 3: 9.4 ↙ 4: 9.4 ↘ 5: 10.2x ← 6: 10.2x ↓ 7: 10.1 ↖ 8: 10.5x ↗ 9: 9.2 ↘ 10: 10.1 ↘	<b>Prov</b> 	11: 10.4x ↗	
Serie 95	Total 0	Serie 10	Total 0	
<b>40 Skott</b> 	1: 10.4x ↗ 2: 10.1 ↗ 3: 10.0 ↖ 4: 9.6 ← 5: 10.7x ↗ 6: 10.4x ↖ 7: 9.7 ← 8: 10.7x ↖ 9: 9.8 ← 10: 10.3x ↗	<b>40 Skott</b> 	11: 10.1 ← 12: 9.3 ↖ 13: 10.1 ← 14: 10.4x ↖ 15: 10.5x ↖ 16: 10.7x ← 17: 8.9 ← 18: 9.3 ↗ 19: 9.2 ↑ 20: 9.8 ↑	
Serie 97	Total 97	Serie 94	Total 191	
<b>40 Skott</b> 	21: 10.4x ↖ 22: 9.7 ↘ 23: 10.1 ↖ 24: 10.4x ← 25: 10.0 ↑ 26: 10.5x ↓ 27: 8.6 ← 28: 10.7x ↖ 29: 10.3x ↑ 30: 9.8 ↑	<b>40 Skott</b> 	31: 10.8x → 32: 9.3 ↗ 33: 9.6 ↖ 34: 9.6 ↗ 35: 10.2x ↖ 36: 10.3x ↖ 37: 10.4x ↖ 38: 10.3x ↖ 39: 10.6x ↗ 40: 10.2x ↗	
Serie 96	Total 287	Serie 97	Total 384	

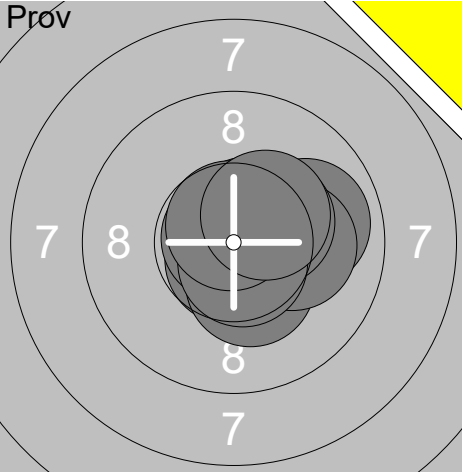
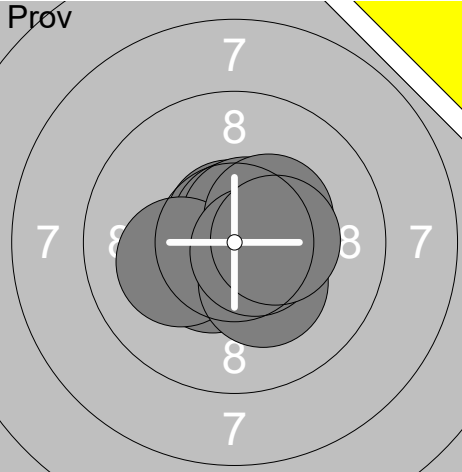
Skjutlag	Tavla	Alva Hägglund		
1	29	Ramselefors	Ramselefors	11 Vb
03.11.2019	Vindelnskyttet 2019	Ramselefors SKF		
<b>Pröv</b> 	1: 9.3 ↑ 2: 9.1 ↑ 3: 10.0 ↗ 4: 10.0 → 5: 9.8 ↑ 6: 10.0 ↑ 7: 10.4x → 8: 10.0 ↑ 9: 10.0 ↑ 10: 9.8 → Serie 96 Total 0	<b>Pröv</b> 	11: 10.1 ↑ 12: 10.1 ↗ 13: 10.2x ↓ 14: 10.0 → 15: 10.2x ↓ 16: 10.2x → 17: 10.3x ↑ 18: 9.9 ↑ 19: 10.8x ↑ 20: 10.5x ↑ Serie 99 Total 0	
<b>Pröv</b> 	21: 9.6 ↓ 22: 9.4 ↓ 23: 10.8x ↖ Serie 28 Total 0	<b>40 Skott</b> 	1: 9.9 ↑ 2: 9.6 ↑ 3: 10.0 → 4: 10.0 ↗ 5: 9.7 ↗ 6: 10.2x ↗ 7: 10.2x ↓ 8: 10.1 ↑ 9: 10.7x ↖ 10: 10.8x ↗ Serie 97 Total 97	
<b>40 Skott</b> 	11: 10.7x ↖ 12: 10.7x ↑ 13: 9.8 ↑ 14: 10.3x ↖ 15: 10.5x ↗ 16: 10.0 ↓ 17: 10.5x ↓ 18: 9.9 ↖ 19: 10.2x ↓ 20: 10.0 ↓ Serie 98 Total 195	<b>40 Skott</b> 	21: 10.2x ↑ 22: 9.4 ↑ 23: 10.4x → 24: 10.7x ↖ 25: 10.3x ↗ 26: 9.9 → 27: 9.9 ↖ 28: 10.0 ↑ 29: 10.6x ↗ 30: 10.4x ↖ Serie 97 Total 292	
<b>40 Skott</b> 	31: 10.1 → 32: 10.6x → 33: 9.9 ↖ 34: 10.9x ↗ 35: 9.8 ↑ 36: 10.4x ↖ 37: 10.6x ↖ 38: 10.5x ↖ 39: 10.8x ↓ 40: 10.0 ↗ Serie 98 Total 390			

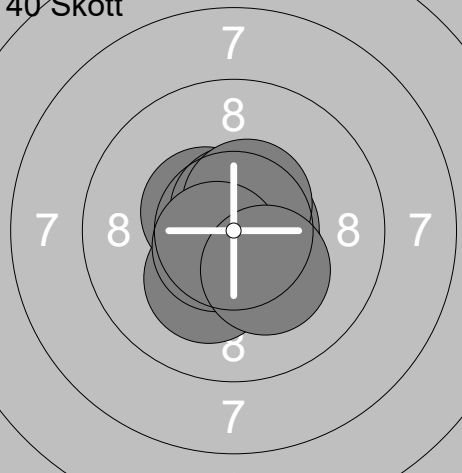
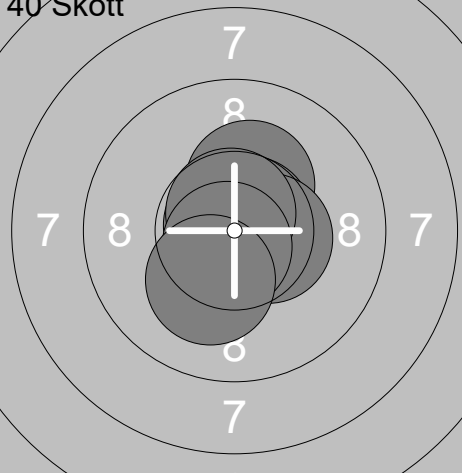
Skjuttag <b>1</b>	Tavla <b>30</b>	<b>Tilda Rosendahl</b>	
Ramselefors	Ramselefors	11	Vb
03.11.2019	Vindelnskyttet 2019	Ramselefors SKF	
<b>Prov</b> 	1: 9.6 ↓ 2: 10.2x → 3: 10.2x → 4: 10.3x ← 5: 10.6x ↓ 6: 10.7x → 7: 10.8x ↓	<b>40 Skott</b> 	1: 10.5x ↖ 2: 10.7x ↗ 3: 10.3x ← 4: 10.7x ← 5: 10.7x → 6: 10.7x ↖ 7: 10.4x ↑ 8: 10.0 ↓ 9: 10.1 → 10: 10.7x ↓
	Serie 69		Serie 100
	Total 0		Total 100
<b>40 Skott</b> 	11: 10.1 ↗ 12: 10.5x ↑ 13: 10.5x ↓ 14: 10.2x → 15: 10.3x ↑ 16: 10.6x ↖ 17: 10.3x ↖ 18: 10.7x ↖ 19: 10.7x ↑ 20: 10.6x ↗	<b>40 Skott</b> 	21: 10.4x ↗ 22: 10.4x ← 23: 10.8x ← 24: 10.4x → 25: 10.4x ↙ 26: 10.7x ↑ 27: 10.3x ↑ 28: 10.6x → 29: 10.7x ↗ 30: 10.8x →
	Serie 100		Serie 100
	Total 200		Total 300
<b>40 Skott</b> 	31: 10.7x ↑ 32: 10.7x ↖ 33: 10.5x ↗ 34: 10.6x ↓ 35: 10.6x ↗ 36: 10.5x ↖ 37: 10.2x ↙ 38: 9.9 ← 39: 10.7x ↓ 40: 10.4x ←		
	Serie 99		
	Total 399		

Skjutlag <b>1</b>	Tavla <b>31</b>	<b>Rasmus Alfredsson</b>		
Ramselefors		Umeå	11	Vb
03.11.2019		Vindelnskyttet 2019	Ramselefors SKF	
<b>Prov</b> 	1: 9.9 → 2: 10.7x ↓ 3: 10.3x ↓ 4: 10.1 → 5: 10.8x ↗ 6: 10.6x ↗ 7: 10.4x ↗ 8: 10.6x ↓ 9: 10.7x ↑ 10: 10.4x ↗ Serie 99 Total 0	<b>Prov</b> 	11: 10.7x ↑ 12: 10.8x ↗ 13: 10.7x ↑ 14: 10.5x ↓ 15: 10.6x ↗ 16: 10.2x ← 17: 10.4x ↗ 18: 10.3x ↓ 19: 10.6x → 20: 10.4x → Serie 100 Total 0	
<b>Prov</b> 	21: 10.4x ← 22: 10.8x ↑ Serie 20 Total 0	<b>40 Skott</b> 	1: 10.8x ↗ 2: 10.6x ↓ 3: 10.9x ↓ 4: 10.5x → 5: 10.7x ↗ 6: 10.5x ↗ 7: 10.6x ← 8: 10.6x ↓ 9: 10.6x ← 10: 10.9x ↓ Serie 100 Total 100	
<b>40 Skott</b> 	11: 10.6x ↗ 12: 10.5x ↗ 13: 10.7x → 14: 10.6x ↓ 15: 10.7x ↑ 16: 10.2x ↓ 17: 10.7x → 18: 10.5x ↑ 19: 10.6x ← 20: 10.2x ↓ Serie 100 Total 200	<b>40 Skott</b> 	21: 10.8x ↗ 22: 10.7x ↓ 23: 10.3x ↑ 24: 10.8x ↓ 25: 10.7x ↗ 26: 10.8x ↗ 27: 10.5x → 28: 10.7x ↑ 29: 10.7x ↓ 30: 10.2x ↓ Serie 100 Total 300	
<b>40 Skott</b> 	31: 10.5x → 32: 10.5x → 33: 10.7x ↗ 34: 10.6x → 35: 10.5x ↑ 36: 10.6x ↗ 37: 10.5x → 38: 10.4x ← 39: 10.7x ↑ 40: 10.8x → Serie 100 Total 400			

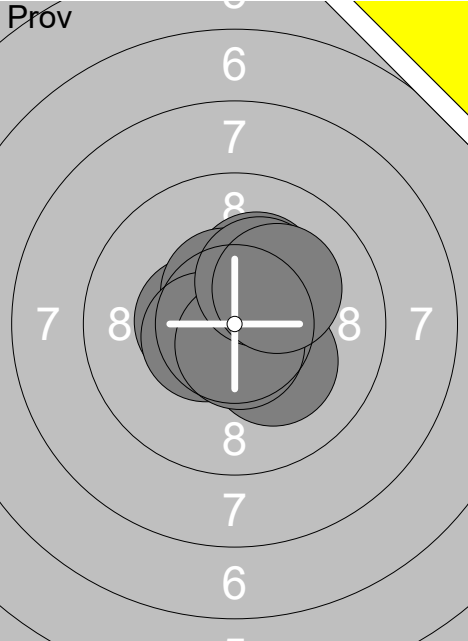
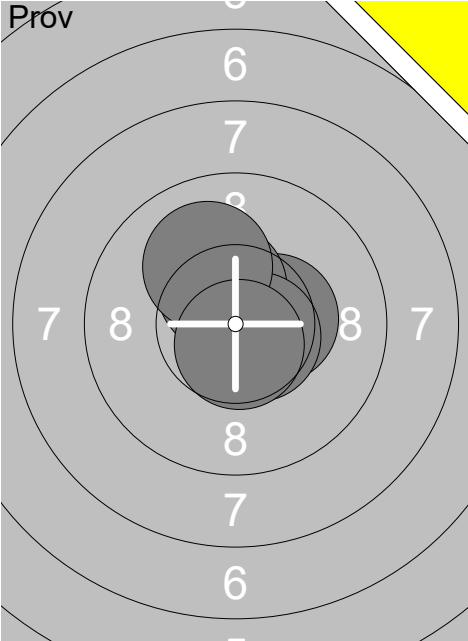
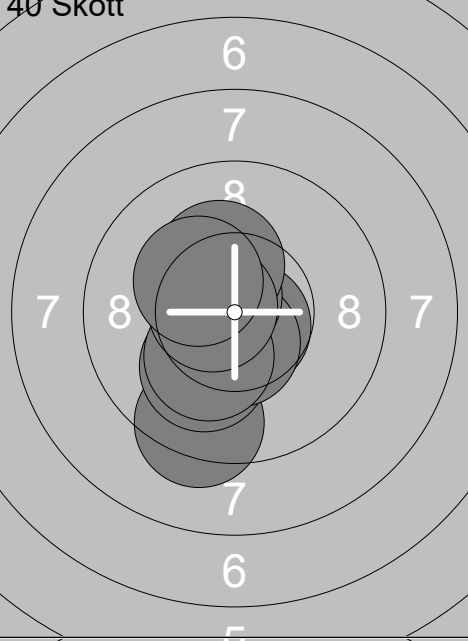
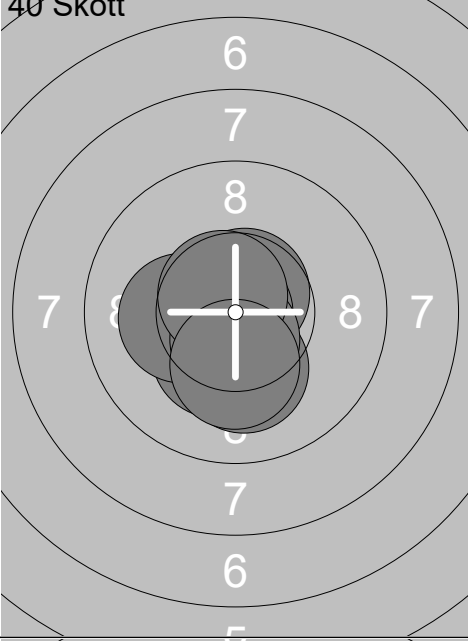
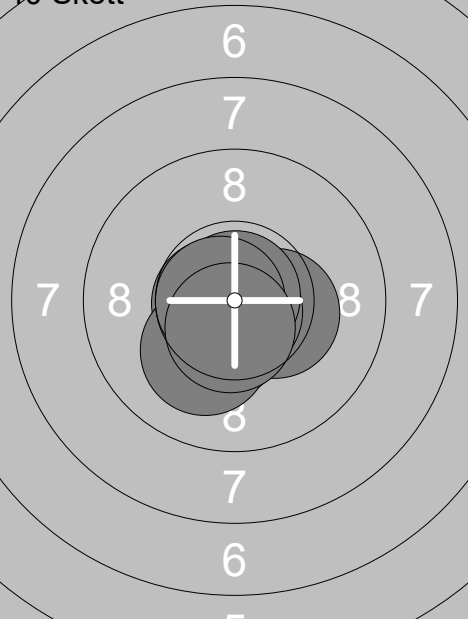
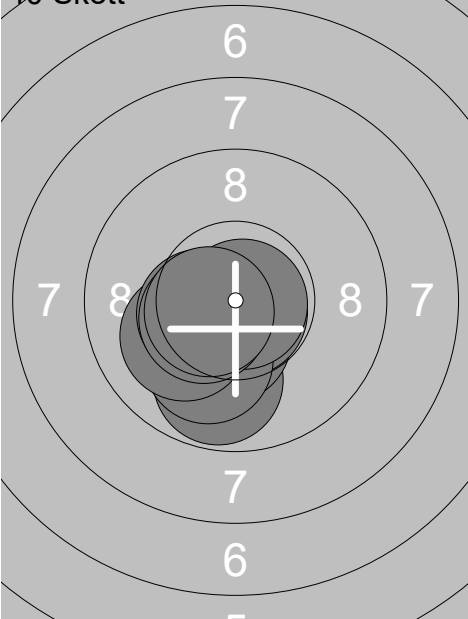

Skjuttag	Tavla	Tilde Holmqvist			
1	32	Ramselefors	Gällivare	13 No	
03.11.2019	Vindelnskyttet 2019	Ramselefors SKF			
Prov		1: 10.2x ↘	Prov		11: 10.4x →
		2: 10.6x ↗			12: 10.4x ↗
		3: 10.7x ↖			13: 10.6x ↘
		4: 10.2x ↗		14: 10.1 ↗	
		5: 10.5x ←		15: 10.7x ↓	
		6: 10.5x ↗			
		7: 10.5x ←			
		8: 10.7x ↓			
		9: 10.3x ↗			
		10: 10.2x ↗			
	Serie 100			Serie 50	
	Total 0			Total 0	
40 Skott		1: 10.8x ↘	40 Skott		11: 10.7x ↗
		2: 10.7x ↘			12: 10.2x ↓
		3: 9.3 ↓			13: 10.5x ↘
		4: 10.1 ↓		14: 10.7x ←	
		5: 10.5x ↓		15: 10.8x ←	
		6: 10.2x ↓		16: 10.3x ↓	
		7: 10.6x ↖		17: 10.2x ←	
		8: 10.3x ↗		18: 10.6x ↓	
		9: 10.6x ←		19: 10.7x ↖	
		10: 10.3x ↖		20: 10.2x ↓	
	Serie 99			Serie 100	
	Total 99			Total 199	
40 Skott		21: 10.7x ←	40 Skott		31: 9.8 ↓
		22: 10.7x ↘			32: 10.3x ↘
		23: 10.4x →			33: 10.4x ↓
		24: 10.8x ↓		34: 10.8x ↘	
		25: 10.9x ↗		35: 10.1 ↓	
		26: 10.4x ↓		36: 10.1 ↖	
		27: 10.6x ↘		37: 10.4x ←	
		28: 10.1 ↓		38: 10.8x ↘	
		29: 10.7x ←		39: 10.4x ←	
		30: 10.6x ↓		40: 10.6x ←	
	Serie 100			Serie 99	
	Total 299			Total 398	

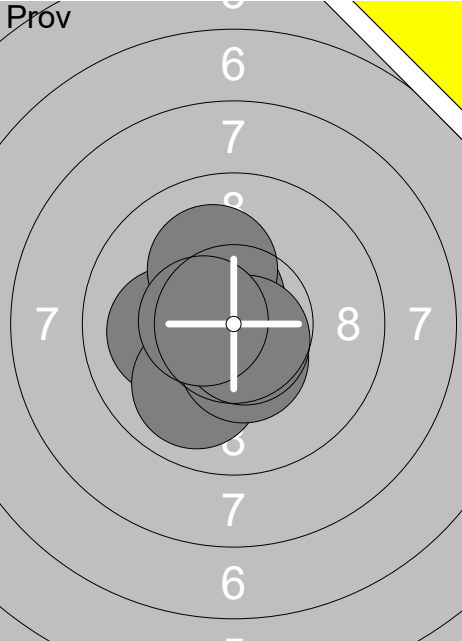
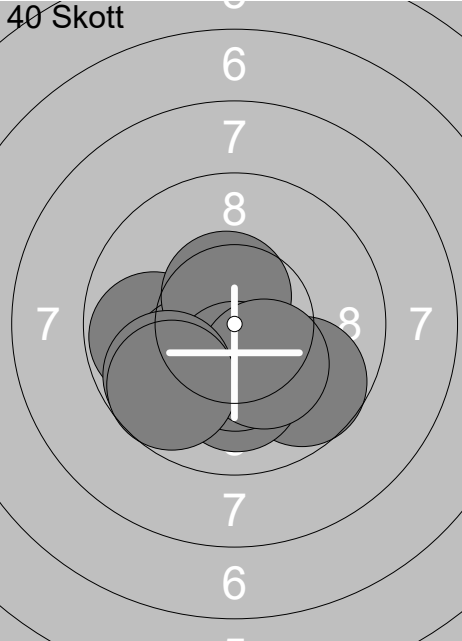
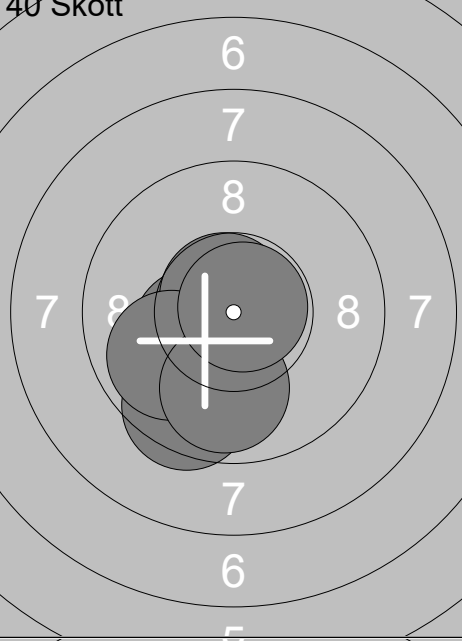
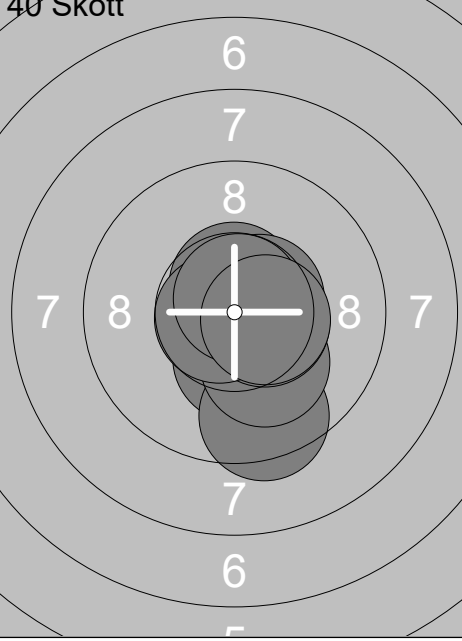
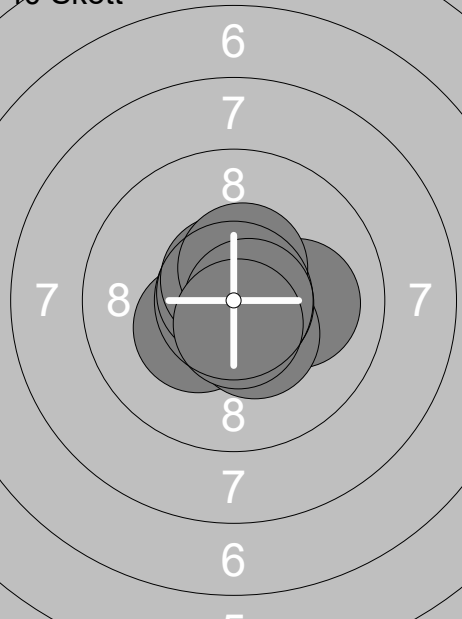

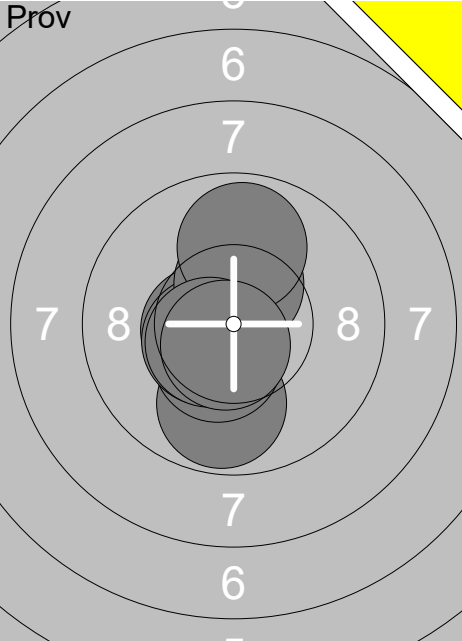
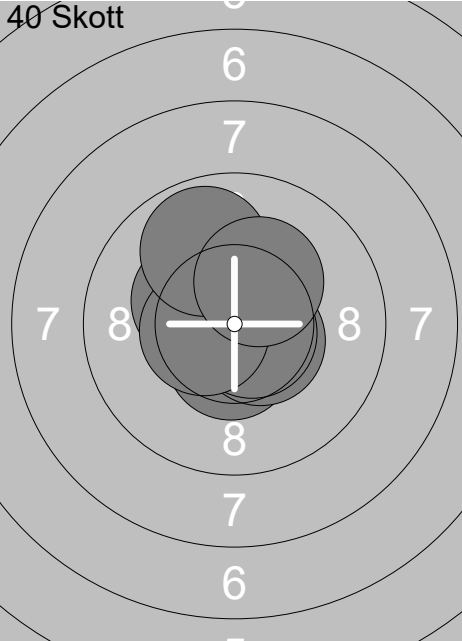
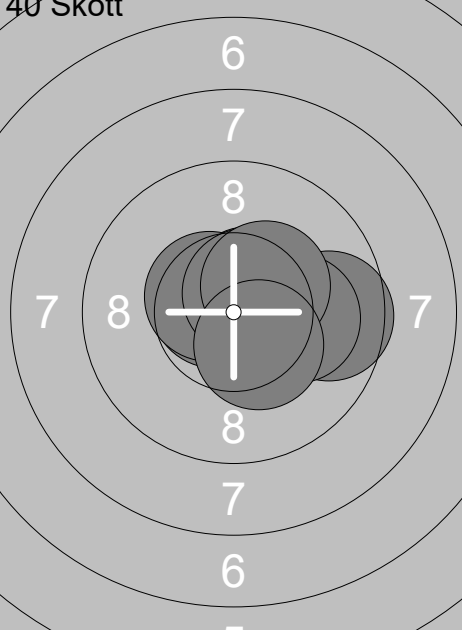
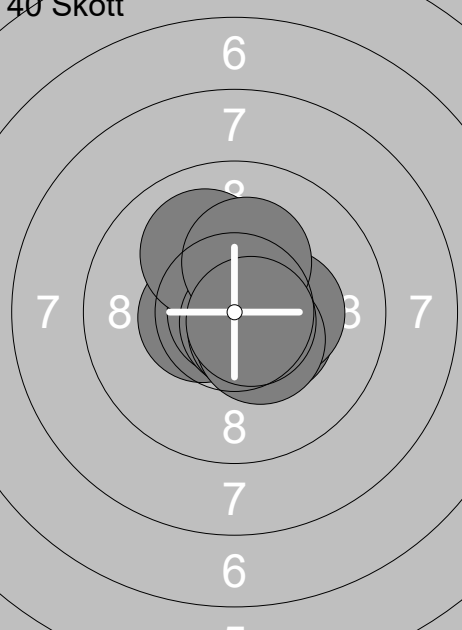
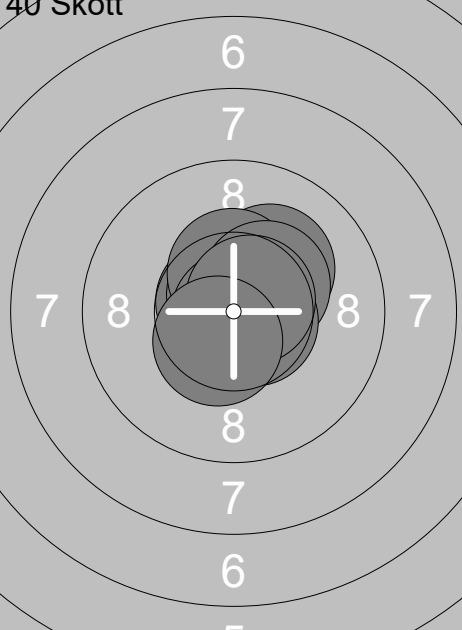
Skjutlag <b>1</b>	Tavla <b>33</b>	<b>Sofia Öhman</b>		
Ramselefors		Gällivare	13	No
03.11.2019		Vindelnskyttet 2019	Ramselefors SKF	
<b>Prov</b> 	1: 10.3x ↘	<b>40 Skott</b> 	1: 10.5x ↗	
	2: 10.4x ↘		2: 10.4x →	
	3: 10.4x ↑		3: 10.4x ↑	
	4: 10.0 ↑	4: 10.8x ↗	4: 10.8x ↗	
	5: 10.4x ↖	5: 9.5 ↑	5: 9.5 ↑	
	6: 10.4x ↗	6: 9.9 ↑	6: 9.9 ↑	
	7: 10.5x ↗	7: 10.8x ↖	7: 10.8x ↖	
		8: 10.7x ←	8: 10.7x ←	
		9: 10.6x ↙	9: 10.6x ↙	
		10: 10.6x ←	10: 10.6x ←	
	Serie 70		Serie 98	
	Total 0		Total 98	
<b>40 Skott</b> 	11: 10.3x ←	<b>40 Skott</b> 	21: 10.5x ↘	
	12: 10.7x ↗		22: 10.7x →	
	13: 10.7x →		23: 10.7x ↖	
	14: 10.8x ←	24: 10.6x ↘	24: 10.6x ↘	
	15: 10.5x ←	25: 10.4x ↘	25: 10.4x ↘	
	16: 10.4x ↙	26: 10.7x ↘	26: 10.7x ↘	
	17: 10.9x ↘	27: 10.6x ↘	27: 10.6x ↘	
	18: 10.8x ←	28: 10.6x ↘	28: 10.6x ↘	
	19: 10.5x ↘	29: 10.2x ↙	29: 10.2x ↙	
	20: 10.6x →	30: 10.7x →	30: 10.7x →	
	Serie 100		Serie 100	
	Total 198		Total 298	
<b>40 Skott</b> 	31: 10.9x ←			
	32: 10.6x ↙			
	33: 10.3x ↑			
	34: 10.6x →			
	35: 10.2x ↘			
	36: 10.7x ↘			
	37: 10.3x ↙			
	38: 10.6x ↘			
	39: 10.6x ↙			
	40: 10.6x ↑			
	Serie 100			
	Total 398			

Skjutlag <b>1</b>	Tavla <b>34</b>	<b>Filip Hansson</b>	
Ramselefors	Vännäs	13	Vb
03.11.2019	Vindelnskyttet 2019	Ramselefors SKF	
<b>Prov</b> 	1: 10.6x ↗ 2: 10.1 ← 3: 10.1 ↗ 4: 10.0 ↘ 5: 10.5x ↘ 6: 10.7x ↘ 7: 10.5x ←	<b>40 Skott</b> 	1: 10.2x ↙ 2: 9.7 ↘ 3: 9.8 ← 4: 10.1 ↓ 5: 10.2x ↙ 6: 10.5x ↗ 7: 10.4x ↓ 8: 10.3x ↘ 9: 9.8 ↙ 10: 9.7 ↘
	Serie 70		Serie 96
	Total 0		Total 96
<b>40 Skott</b> 	11: 10.1 ↙ 12: 9.5 ↘ 13: 10.1 ↙ 14: 10.4x ↙ 15: 10.4x ↘ 16: 10.0 ↙ 17: 10.7x ↗ 18: 9.9 ← 19: 9.9 ↓ 20: 10.8x ↗	<b>40 Skott</b> 	21: 10.3x ↓ 22: 10.6x ↑ 23: 10.6x → 24: 9.4 ↓ 25: 10.1 ↘ 26: 10.6x ↗ 27: 10.5x → 28: 10.7x ↙ 29: 10.8x ↑ 30: 10.5x →
	Serie 97		Serie 99
	Total 193		Total 292
<b>40 Skott</b> 	31: 10.7x ↘ 32: 10.6x ↗ 33: 10.1 → 34: 10.3x ↙ 35: 10.4x ↘ 36: 10.8x ↙ 37: 10.6x ↗ 38: 10.5x ↑ 39: 10.7x → 40: 10.6x ↓		
	Serie 100		
	Total 392		

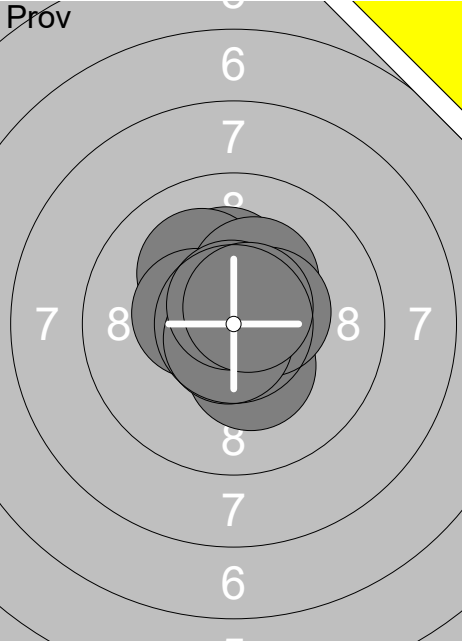
Skjuttag	Tavla	Casper Fredriksson			
1	36	Ramselefors	Ramselefors	Rem	Vb
03.11.2019	Vindelnskyttet 2019	Ramselefors SKF			
<b>Prov</b> 	1: 9.8 ↓ 2: 10.4x ↓ 3: 10.6x ← 4: 10.6x ↙ 5: 10.6x ↘ 6: 10.5x ↙ 7: 10.4x ↑ 8: 9.9 ↑ 9: 10.5x ↙ 10: 10.6x ↓ Serie 98 Total 0	<b>40 Skott</b> 	1: 10.3x ↖ 2: 10.5x ↓ 3: 10.5x ↘ 4: 10.6x ↗ 5: 10.8x ↗ 6: 10.7x ↘ 7: 10.6x ↗ 8: 10.5x ← 9: 9.9 ↑ 10: 10.3x ↗ Serie 99 Total 99		
<b>40 Skott</b> 	11: 10.7x ↖ 12: 9.6 → 13: 10.1 → 14: 10.6x ↗ 15: 10.6x ↗ 16: 10.7x → 17: 10.5x ↖ 18: 10.6x ↗ 19: 10.4x ↗ 20: 10.4x ↓ Serie 99 Total 198	<b>40 Skott</b> 	21: 10.5x ← 22: 10.4x ↘ 23: 10.9x ← 24: 10.1 ↗ 25: 10.7x ↓ 26: 10.3x → 27: 10.6x ↓ 28: 10.4x ↓ 29: 10.2x ↑ 30: 10.7x ↘ Serie 100 Total 298		
<b>40 Skott</b> 	31: 10.7x ↖ 32: 10.5x ↗ 33: 10.2x ↗ 34: 10.7x ↑ 35: 10.4x ↑ 36: 10.4x ↗ 37: 10.9x ↓ 38: 10.6x ↘ 39: 10.7x ↗ 40: 10.5x ↓ Serie 100 Total 398				

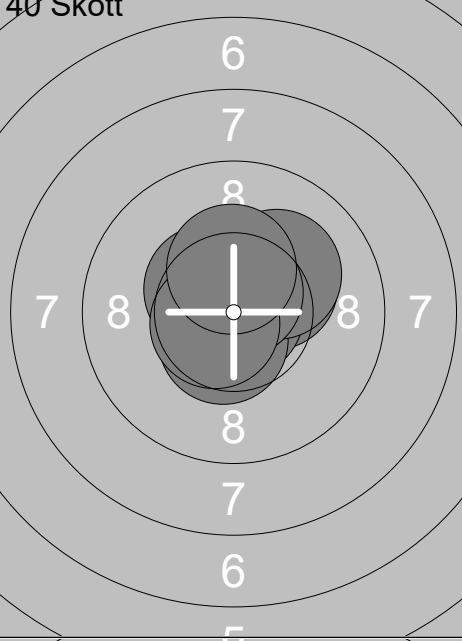
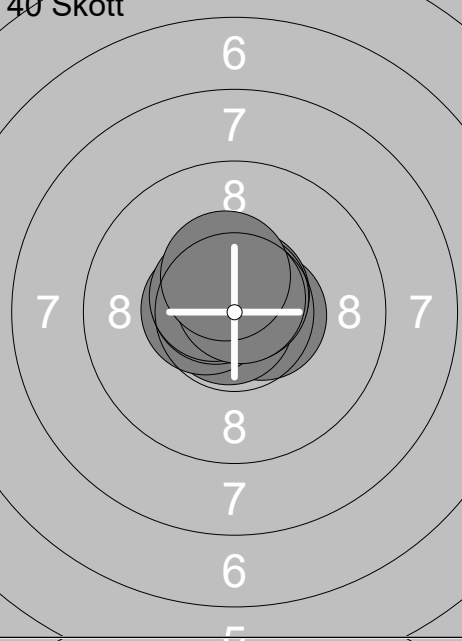
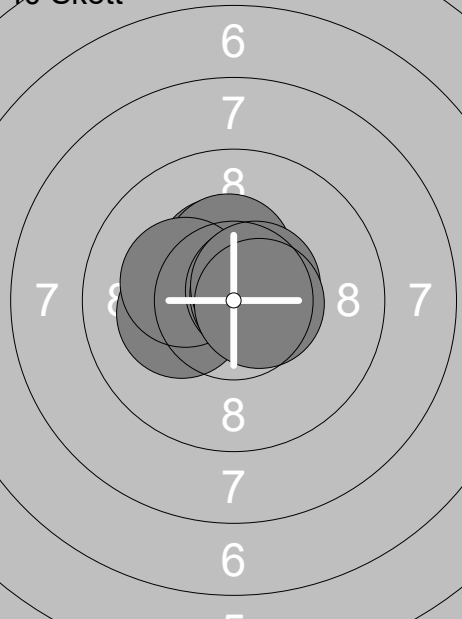
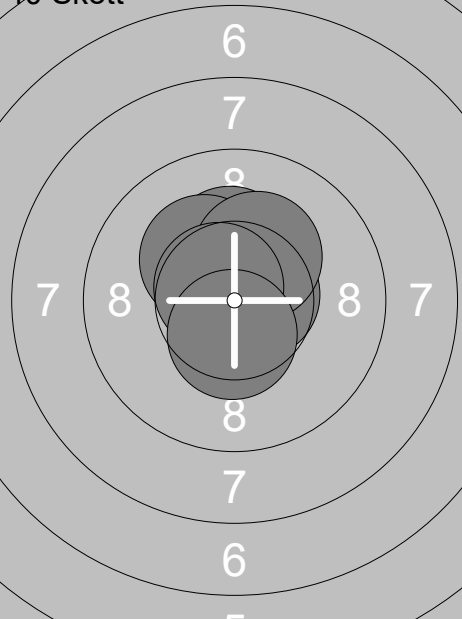

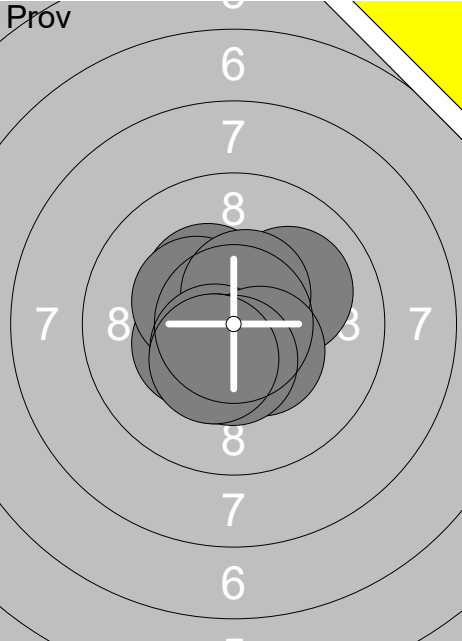
Skjutlag	Tavla	Rådgård Chen Brinkstam		
1	37	Umeå	13	Vb
03.11.2019	Vindelnskytten 2019	Ramselefors SKF		
<b>Prov</b> 	1: 10.2x ↑ 2: 10.1 ↖ 3: 10.3x ↗ 4: 10.7x ← 5: 10.4x ← 6: 10.3x ↓ 7: 10.5x → 8: 10.7x ↓ 9: 10.7x ↑ 10: 10.6x ↗	<b>Prov</b> 	11: 10.8x ← 12: 10.5x ↗	
	Serie 100		Serie 20	
	Total 0		Total 0	
<b>40 Skott</b> 	1: 10.3x ↗ 2: 10.9x ↗ 3: 10.5x ↑ 4: 10.9x → 5: 10.5x ↓ 6: 10.5x ↖ 7: 10.1 ↗ 8: 10.7x ↑ 9: 10.6x ← 10: 10.4x ↑	<b>40 Skott</b> 	11: 10.6x → 12: 10.8x ↙ 13: 10.7x ↗ 14: 10.6x ↖ 15: 10.7x ↗ 16: 10.5x ← 17: 10.6x ↖ 18: 10.6x ↖ 19: 10.7x ↗ 20: 10.4x ↑	
	Serie 100		Serie 100	
	Total 100		Total 200	
<b>40 Skott</b> 	21: 10.2x ← 22: 10.4x ↑ 23: 10.6x ↖ 24: 10.5x ↖ 25: 10.4x ↑ 26: 10.2x ← 27: 10.7x ↗ 28: 10.6x → 29: 10.6x ↗ 30: 10.6x →	<b>40 Skott</b> 	31: 10.3x ↑ 32: 10.2x ↖ 33: 10.7x ↗ 34: 10.7x ↑ 35: 10.7x ↗ 36: 10.7x ↗ 37: 10.7x → 38: 10.3x ↗ 39: 10.7x ↖ 40: 10.5x ↓	
	Serie 100		Serie 100	
	Total 300		Total 400	

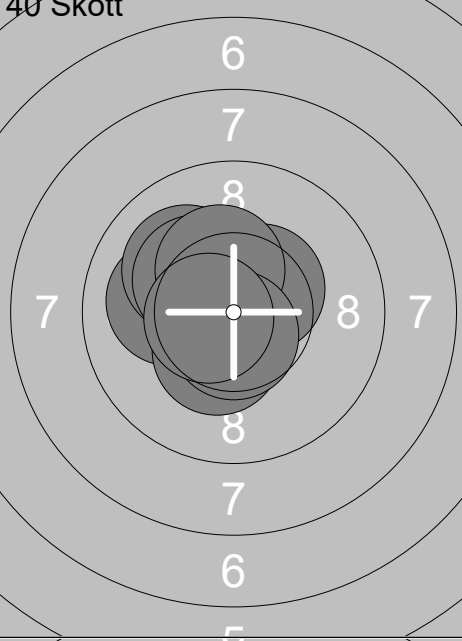
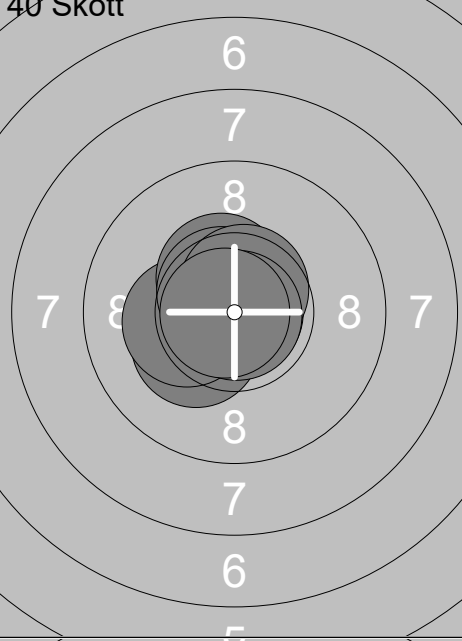
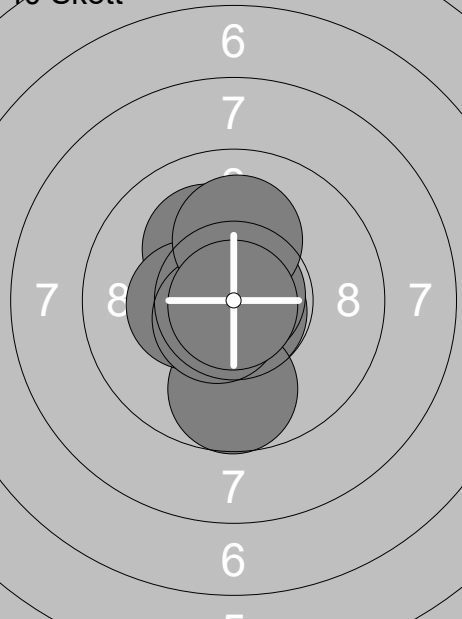
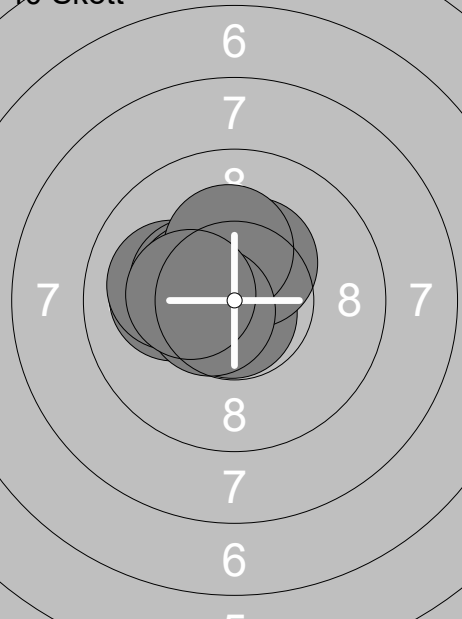
Skjutlag	Tavla	Hanna Augustsson	
1	38	Ramselefors	Vännäs
03.11.2019	Vindelnskyttet 2019	Ramselefors SKF	Sitt Vb
<b>Prov</b> 	1: 10.1 ↗	<b>Prov</b> 	11: 10.6x ↗
	2: 10.4x ↙		12: 10.5x ↙
	3: 10.3x ↘		13: 10.9x ↘
	4: 10.3x ↖		
	5: 10.5x ↗		
	6: 10.5x ↘		
	7: 10.4x ↘		
	8: 10.4x ↘		
	9: 10.4x ↘		
	10: 10.4x ↘		
	Serie 100		Serie 30
	Total 0		Total 0
<b>40 Skott</b> 	1: 10.5x ↘	<b>40 Skott</b> 	11: 10.3x ↙
	2: 10.5x ↗		12: 10.3x ↙
	3: 10.7x ↙		13: 10.9x →
	4: 10.1 ↙		14: 10.8x ↗
	5: 10.1 ↘		15: 10.4x ↗
	6: 10.4x ↘		16: 10.6x ↘
	7: 10.3x ↘		17: 10.8x ↗
	8: 10.3x ↗		18: 10.6x ↗
	9: 10.6x ↘		19: 10.9x ↘
	10: 10.6x ↙		20: 10.8x ↙
	Serie 100		Serie 100
	Total 100		Total 200
<b>40 Skott</b> 	21: 10.8x ↘	<b>40 Skott</b> 	31: 10.1 ↙
	22: 10.8x ↘		32: 10.1 ↙
	23: 10.5x ↗		33: 10.3x ↙
	24: 10.1 ↗		34: 10.8x ↗
	25: 9.7 ↘		35: 10.8x ↘
	26: 10.4x ↙		36: 10.4x ↗
	27: 10.8x ↗		37: 10.4x ↙
	28: 10.6x ↘		38: 10.2x ↗
	29: 10.1 ↗		39: 10.6x ↙
	30: 10.9x ↘		40: 10.3x ↙
	Serie 99		Serie 100
	Total 299		Total 399

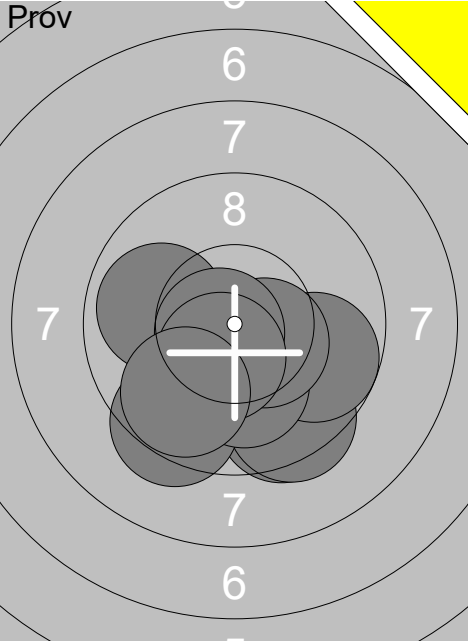
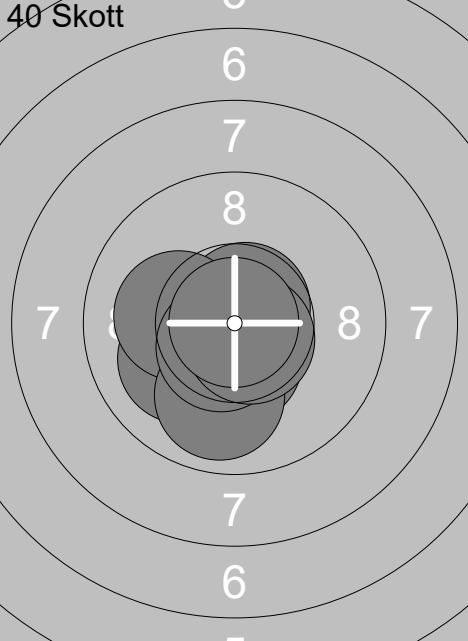
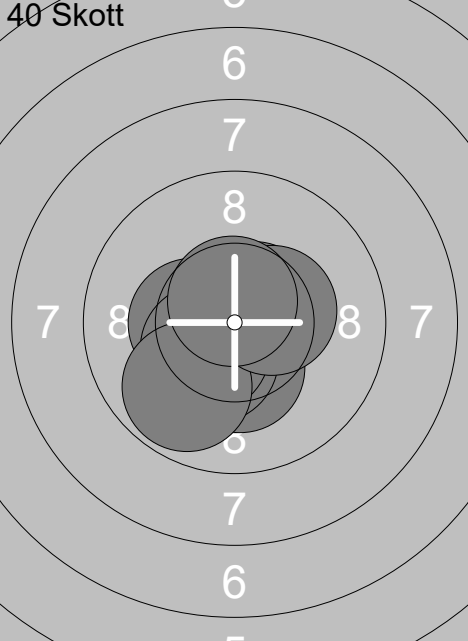
Skjuttag	Tavla	Jennifer Gustafsson			
1	39	Ramselefors	Ramselefors	Rem	Vb
03.11.2019	Vindelnskyttet 2019	Ramselefors SKF			
Prov		1: 9.5 ↘ 2: 9.4 ↘ 3: 9.4 ↘ 4: 9.8 → 5: 10.1 ↓ 6: 10.5x → 7: 9.9 ← 8: 10.7x ← 9: 10.5x ↓ 10: 9.8 ↘	Prov	11: 10.4x ↓	
		Serie 94		Serie 10	
		Total 0		Total 0	
40 Skott		1: 10.1 ← 2: 10.7x ↗ 3: 10.5x ← 4: 10.4x ↓ 5: 10.2x ← 6: 9.9 ↓ 7: 10.7x ↓ 8: 10.6x ↓ 9: 10.7x ↘ 10: 10.9x ↗	40 Skott	11: 10.6x ↓ 12: 10.8x ↓ 13: 10.5x ← 14: 10.7x ↓ 15: 10.3x ← 16: 10.1 ← 17: 10.7x → 18: 10.9x ↓ 19: 10.1 ↓ 20: 10.5x ↓	
		Serie 99		Serie 100	
		Total 99		Total 199	
40 Skott		21: 10.7x ↓ 22: 10.3x ↓ 23: 10.6x ↗ 24: 10.7x ↑ 25: 10.4x ← 26: 10.4x ↓ 27: 10.4x ← 28: 9.8 ↓ 29: 10.4x → 30: 10.6x ↑	40 Skott	31: 10.4x ← 32: 10.6x → 33: 10.4x ↓ 34: 10.5x ↓ 35: 10.7x ↓ 36: 10.4x ↗ 37: 10.1 ← 38: 9.8 ← 39: 10.2x → 40: 10.0 ↓	
		Serie 99		Serie 99	
		Total 298		Total 397	

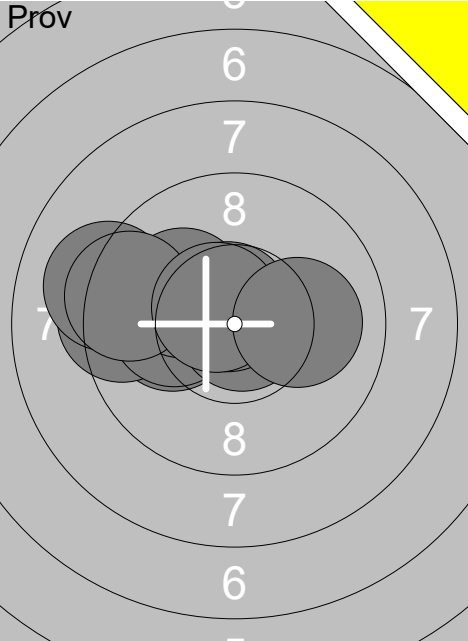
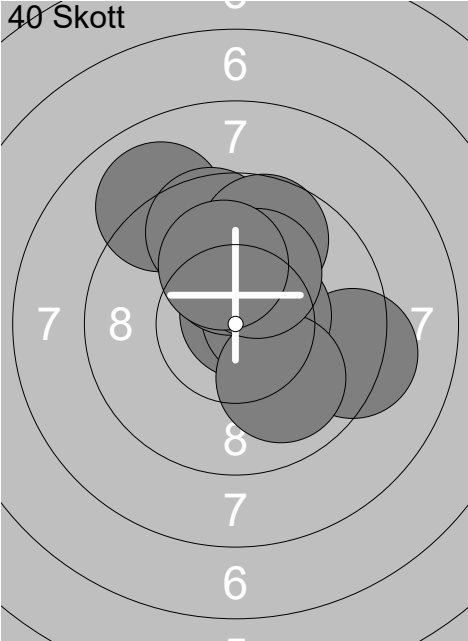
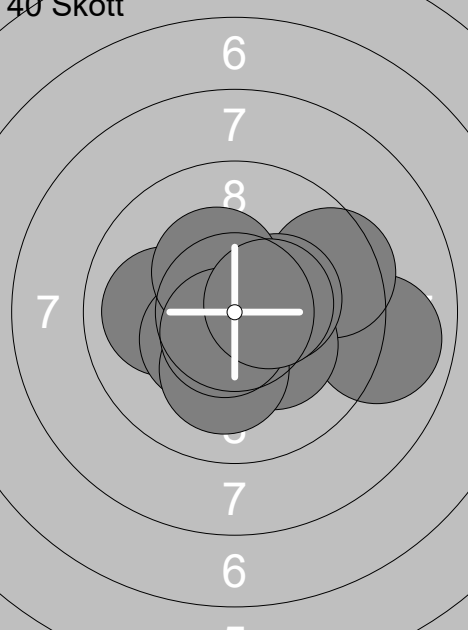
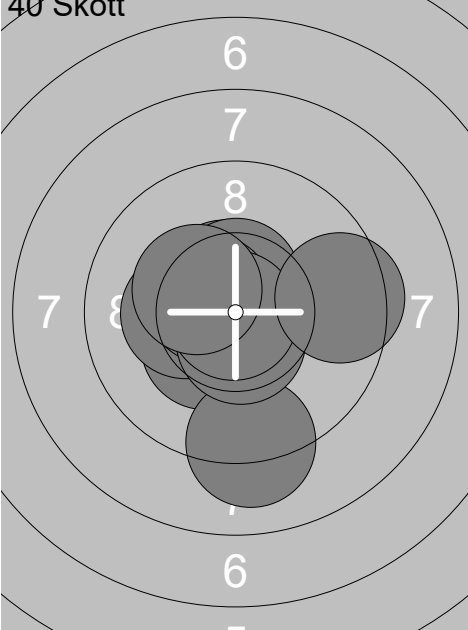
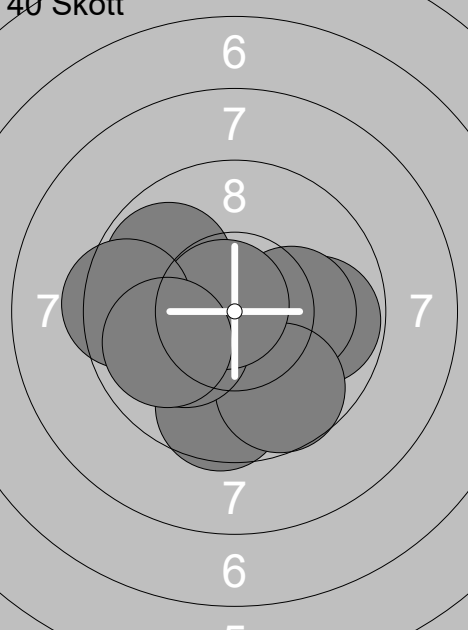
Skjutlag	Tavla	Emma Eriksson	
1	40	Ramselefors	Rem Vb
03.11.2019	Vindelnskyttet 2019	Ramselefors SKF	
Prov		40 Skott	
	1: 10.1 ← 2: 9.4 ← 3: 9.1 ← 4: 10.1 ← 5: 10.1 ↖ 6: 9.4 ← 7: 10.8x → 8: 10.7x ↗ 9: 10.6x ↖ 10: 10.1 →		1: 9.0 ↖ 2: 9.6 ↑ 3: 10.8x ↗ 4: 9.3 → 5: 9.7 ↑ 6: 10.5x → 7: 10.0 ↘ 8: 10.2x ↑ 9: 10.2x ↗ 10: 10.1 ↑
	Serie 97		Serie 96
	Total 0		Total 96
40 Skott		40 Skott	
	11: 8.9 → 12: 10.0 ← 13: 9.5 → 14: 10.2x ↘ 15: 10.4x ↙ 16: 10.3x → 17: 10.1 ↓ 18: 10.3x ↗ 19: 10.6x ↘ 20: 10.5x →		21: 10.3x ↙ 22: 9.1 ↓ 23: 10.5x ↗ 24: 10.3x ← 25: 10.6x ↑ 26: 10.6x ↖ 27: 10.6x ↓ 28: 10.9x ↙ 29: 10.3x ↖ 30: 9.5 →
	Serie 97		Serie 98
	Total 193		Total 291
40 Skott			
	31: 9.6 ↓ 32: 10.6x ↘ 33: 9.8 → 34: 10.2x → 35: 9.7 ↓ 36: 9.8 ↖ 37: 10.1 ← 38: 10.8x ↖ 39: 9.4 ← 40: 9.9 ←		
	Serie 94		
	Total 385		

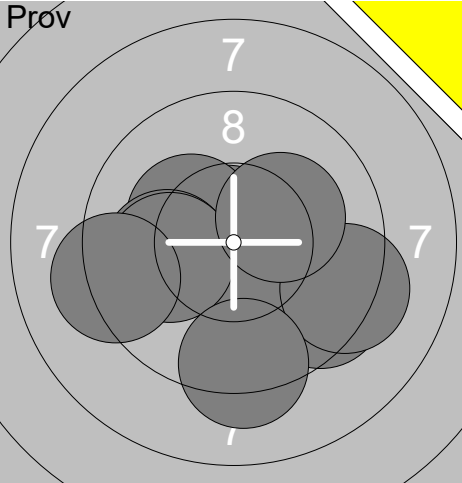
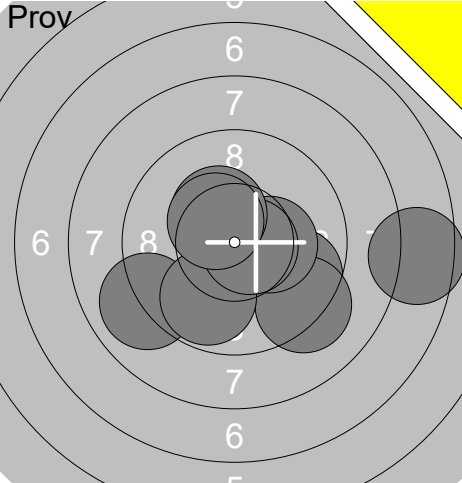
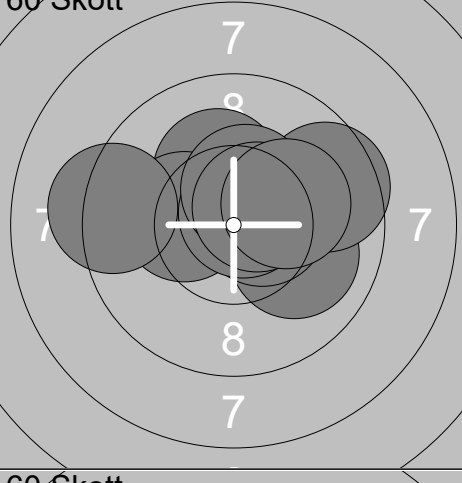
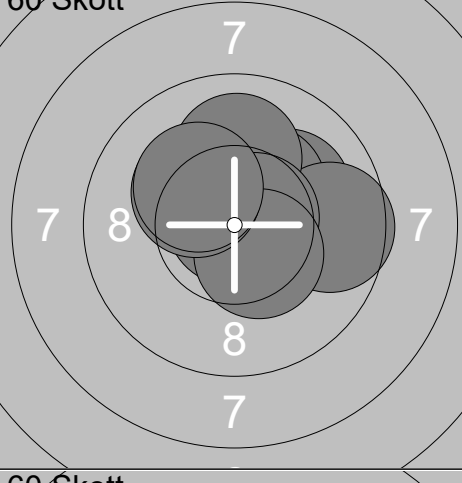
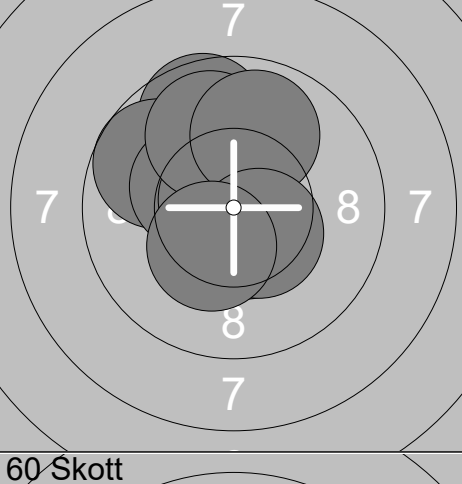
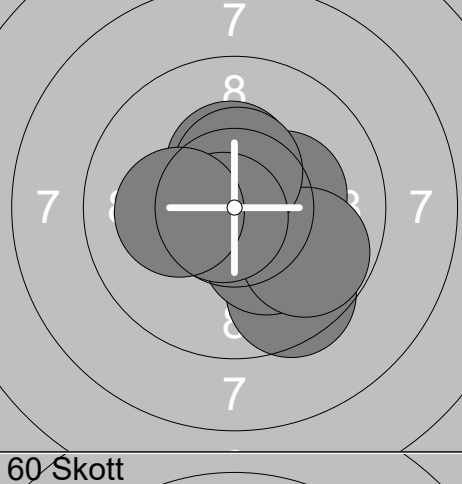
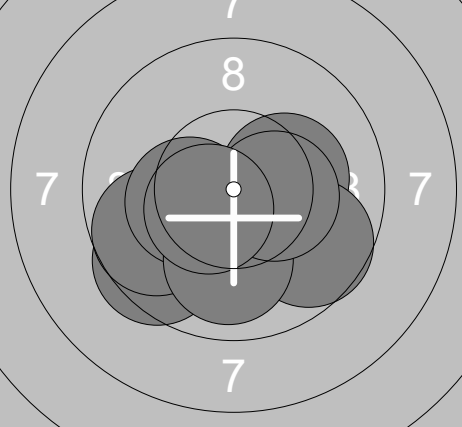
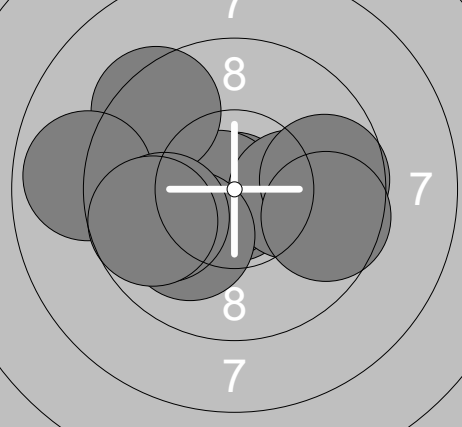
Skjuttag	Tavla	Kevin Westberg		
2	1	Ramselefors	Forsa	17S
03.11.2019	Vindelnskyttet 2019	Ramselefors SKF		
<b>Prov</b> 	1: 10.8x ↗	<b>Prov</b> 	11: 9.7 ↘	
	2: 10.3x ↗		12: 9.0 ↙	
	3: 10.0 ←		13: 9.2 ↘	
	4: 9.5 ↘		14: 10.3x →	
	5: 10.5x ↘		15: 9.8 ↘	
	6: 10.0 ←		16: 7.6 →	
	7: 9.3 ↘		17: 10.7x →	
	8: 10.2x →		18: 10.4x ↗	
	9: 9.2 ←		19: 10.4x ↗	
	10: 9.3 ↓			
Serie	99.1	Serie	87.1	
Total	0.0	Total	0.0	
<b>60 Skott</b> 	1: 10.0 →	<b>60 Skott</b> 	11: 10.4x →	
	2: 10.2x ↗		12: 10.1 ↗	
	3: 10.3x ←		13: 10.3x ↗	
	4: 9.6 →		14: 9.6 →	
	5: 9.3 ←		15: 10.9x ↗	
	6: 10.6x →		16: 10.0 ↑	
	7: 10.7x ↗		17: 10.7x →	
	8: 10.4x ↗		18: 10.4x ↘	
	9: 10.5x ↗		19: 10.2x ↗	
	10: 10.2x →		20: 10.2x ↗	
Serie	101.8	Serie	102.8	
Total	101.8	Total	204.6	
<b>60 Skott</b> 	21: 10.5x ↘	<b>60 Skott</b> 	31: 9.5 ↘	
	22: 9.6 ↗		32: 10.5x ↘	
	23: 10.1 ↑		33: 10.4x ↑	
	24: 9.7 ↗		34: 10.8x ←	
	25: 10.3x ↗		35: 10.2x ↘	
	26: 10.8x ↗		36: 10.3x →	
	27: 9.9 ↗		37: 9.8 ↘	
	28: 9.9 ↗		38: 10.5x ↑	
	29: 10.5x ↘		39: 10.7x ↙	
	30: 10.3x ↘		40: 10.2x ←	
Serie	101.6	Serie	102.9	
Total	306.2	Total	409.1	
<b>60 Skott</b> 	41: 10.4x ↙	<b>60 Skott</b> 	51: 10.8x ↘	
	42: 9.5 ↙		52: 10.7x ←	
	43: 10.3x ↘		53: 9.4 ↗	
	44: 9.7 ↙		54: 10.1 →	
	45: 10.2x →		55: 9.7 →	
	46: 9.7 ↘		56: 8.9 ←	
	47: 10.3x ←		57: 10.1 ↙	
	48: 10.0 ↓		58: 9.9 ←	
	49: 10.4x →		59: 9.7 ←	
	50: 10.5x ↙		60: 9.6 →	
Serie	101.0	Serie	98.9	
Total	510.1	Total	609.0	

Skjutlag	Tavla	Mats Österlund					
2	2	Ramselefors	Ramselefors	Vet	Vb		
03.11.2019	Vindelnskyttet 2019	Ramselefors SKF					
<b>Prov</b> 	1: 9.7 ↙ 2: 9.1 ← 3: 9.0 ← 4: 10.6x ← 5: 8.9 → 6: 10.7x ↙ 7: 9.4 ↗ 8: 8.9 ↓ 9: 10.0 ↗ 10: 9.3 ↓	<b>Prov</b> 	11: 8.8 ↓ 12: 10.2x ↓	Serie	95.6	Serie	19.0
	Total	0.0	Total	0.0			
<b>60 Skott</b> 	1: 10.5x ↗ 2: 9.3 ↓ 3: 8.6 ↗ 4: 8.7 ↑ 5: 8.6 → 6: 10.1 ↗ 7: 9.7 ← 8: 10.2x → 9: 8.9 → 10: 9.9 ↑	<b>60 Skott</b> 	11: 10.2x ← 12: 7.5 → 13: 10.3x ↓ 14: 10.3x ↓ 15: 10.6x ← 16: 9.9 → 17: 9.8 ← 18: 9.8 ↓ 19: 10.0 ↗ 20: 9.0 →	Serie	94.5	Serie	97.4
	Total	94.5	Total	191.9			
<b>60 Skott</b> 	21: 9.7 → 22: 8.9 ↗ 23: 10.2x ↑ 24: 10.6x ↓ 25: 9.4 ↗ 26: 8.4 ↓ 27: 6.8 ↓ 28: 9.9 → 29: 9.6 → 30: 9.6 ←	<b>60 Skott</b> 	31: 9.0 → 32: 10.1 ↑ 33: 9.6 ↗ 34: 9.7 → 35: 9.2 ↓ 36: 9.6 ← 37: 9.5 → 38: 10.2x ← 39: 7.5 ↓ 40: 10.5x →	Serie	93.1	Serie	94.9
	Total	285.0	Total	379.9			
<b>60 Skott</b> 	41: 10.5x ↓ 42: 10.1 ← 43: 9.9 ↓ 44: 8.7 ↓ 45: 10.7x ↓ 46: 10.0 ↓ 47: 10.4x ← 48: 9.9 → 49: 9.6 ↓ 50: 9.8 ↗	<b>60 Skott</b> 	51: 10.1 ← 52: 9.8 ↓ 53: 9.6 → 54: 10.0 ↓ 55: 9.4 → 56: 9.2 ↗ 57: 7.9 ↓ 58: 10.3x ↓ 59: 10.7x → 60: 9.9 ↓	Serie	99.6	Serie	96.9
	Total	479.5	Total	576.4			

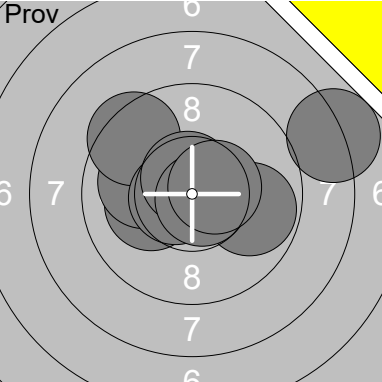
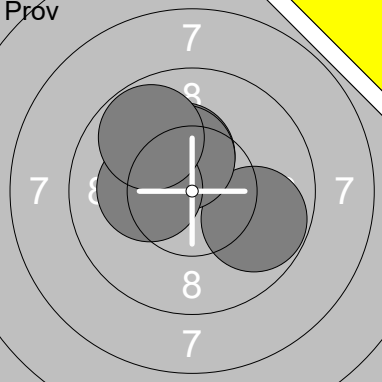
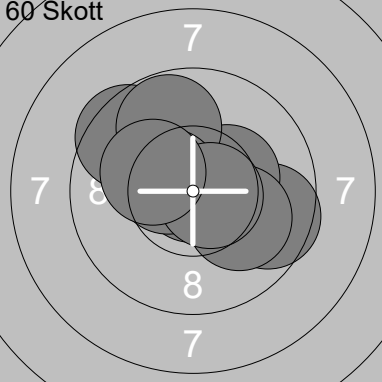
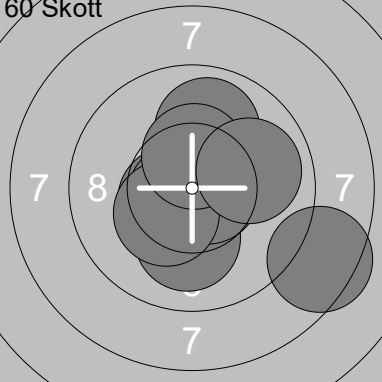
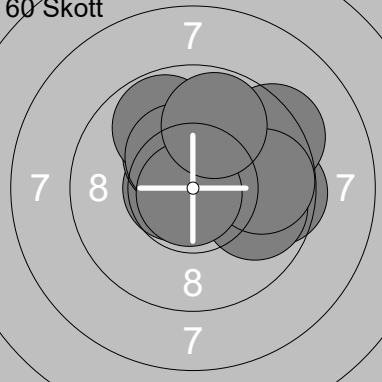
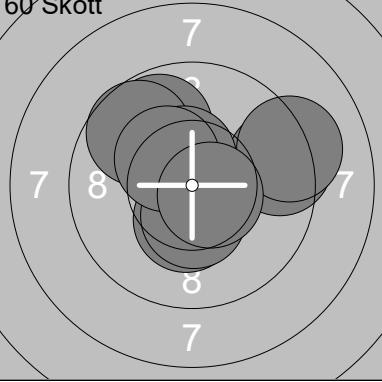
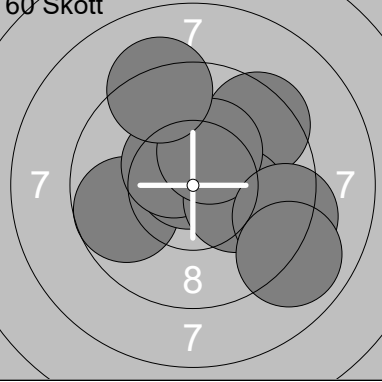
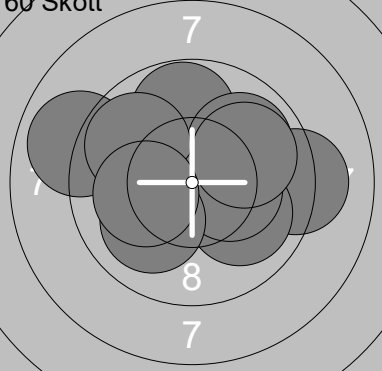
Skjutlag	Tavla	Linus Eriksson	
2	3	Ramselefors	Delsbo-Bjuråker
03.11.2019		Vindelnskyttet 2019	Ramselefors SKF
17S	Gä		
Prov	0	1: 10.2x ←	Prov
	7	2: 10.0 ↖	11: 9.5 →
	8	3: 10.0 ←	12: 9.8 →
	6	4: 9.4 ↗	13: 9.9 ↘
	7	5: 8.0 →	14: 9.4 →
	8	6: 10.6x ←	15: 9.4 →
	7	7: 10.6x ↑	16: 10.2x ↑
	6	8: 9.8 →	17: 10.0 →
	7	9: 10.7x ↘	18: 9.2 →
	6	10: 10.5x →	19: 10.3x ↘
	6	Serie 99.8	20: 10.4x ←
	6	Total 0.0	Serie 98.1
	6		Total 0.0
Prov	7	21: 10.3x ↑	60 Skott
	8	22: 9.8 →	
	7	23: 10.4x ↑	1: 10.8x →
	8	24: 10.2x ←	2: 10.9x ↗
	7	25: 9.8 ↗	3: 9.6 ↘
	7	Serie 50.5	4: 10.3x →
	7	Total 0.0	5: 9.5 ↗
	7		6: 9.8 ↗
	7		7: 10.5x ↗
	7		8: 10.0 ↘
	7		9: 10.6x →
	7		10: 10.2x ↗
	7		Serie 102.2
	7		Total 102.2
60 Skott	7	11: 10.1 ↓	60 Skott
	8	12: 10.5x ←	
	7	13: 10.3x →	21: 10.7x ←
	8	14: 10.7x ←	22: 10.3x ↗
	7	15: 10.7x →	23: 9.8 ↗
	8	16: 10.3x ↘	24: 9.6 →
	7	17: 9.9 ↑	25: 10.4x ↗
	8	18: 10.4x ↑	26: 9.8 →
	7	19: 9.9 →	27: 9.3 ↗
	7	20: 8.5 ↘	28: 9.8 →
	7	Serie 101.3	29: 10.8x ↘
	7	Total 203.5	30: 9.8 ↑
	7		Serie 100.3
	7		Total 303.8
60 Skott	7	31: 9.8 ↗	60 Skott
	8	32: 9.7 ↗	
	7	33: 10.4x ↓	41: 10.4x →
	8	34: 9.4 →	42: 9.7 ←
	7	35: 9.2 →	43: 9.5 ↗
	8	36: 10.5x ↑	44: 10.8x ↗
	7	37: 10.6x ↑	45: 10.5x ↗
	8	38: 10.4x ↓	46: 10.2x →
	7	39: 10.3x ↗	47: 10.3x ↗
	7	40: 10.6x ↘	48: 9.2 ↑
	7	Serie 100.9	49: 9.3 →
	7	Total 404.7	50: 8.9 ↘
	7		Serie 98.8
	7		Total 503.5
60 Skott	7	51: 8.9 ←	
	8	52: 9.8 ↑	
	7	53: 9.2 →	
	8	54: 9.9 ↗	
	7	55: 9.8 ↗	
	8	56: 10.0 ↘	
	7	57: 10.3x →	
	8	58: 10.0 ↘	
	7	59: 10.0 →	
	7	60: 10.1 ←	
	7	Serie 98.0	
	7	Total 601.5	

<b>Prov</b> 	<table style="width:100%; border-collapse: collapse;"> <tr><td>1:</td><td>10.3x</td><td>↑</td></tr> <tr><td>2:</td><td>8.6</td><td>↖</td></tr> <tr><td>3:</td><td>9.3</td><td>←</td></tr> <tr><td>4:</td><td>9.7</td><td>↖</td></tr> <tr><td>5:</td><td>10.5x</td><td>↑</td></tr> <tr><td>6:</td><td>10.1</td><td>↙</td></tr> <tr><td>7:</td><td>10.2x</td><td>↗</td></tr> <tr><td>8:</td><td>10.2x</td><td>↗</td></tr> <tr><td>9:</td><td>10.5x</td><td>↘</td></tr> <tr><td>10:</td><td>10.5x</td><td>↖</td></tr> <tr><td colspan="2">Serie</td><td>99.9</td></tr> <tr><td colspan="2">Total</td><td>0.0</td></tr> </table>	1:	10.3x	↑	2:	8.6	↖	3:	9.3	←	4:	9.7	↖	5:	10.5x	↑	6:	10.1	↙	7:	10.2x	↗	8:	10.2x	↗	9:	10.5x	↘	10:	10.5x	↖	Serie		99.9	Total		0.0	<b>Prov</b> 	<table style="width:100%; border-collapse: collapse;"> <tr><td>11:</td><td>9.9</td><td>→</td></tr> <tr><td>12:</td><td>10.4x</td><td>↓</td></tr> <tr><td>13:</td><td>10.2x</td><td>↗</td></tr> <tr><td>14:</td><td>10.4x</td><td>→</td></tr> <tr><td colspan="2">Serie</td><td>40.9</td></tr> <tr><td colspan="2">Total</td><td>0.0</td></tr> </table>	11:	9.9	→	12:	10.4x	↓	13:	10.2x	↗	14:	10.4x	→	Serie		40.9	Total		0.0																		
1:	10.3x	↑																																																																									
2:	8.6	↖																																																																									
3:	9.3	←																																																																									
4:	9.7	↖																																																																									
5:	10.5x	↑																																																																									
6:	10.1	↙																																																																									
7:	10.2x	↗																																																																									
8:	10.2x	↗																																																																									
9:	10.5x	↘																																																																									
10:	10.5x	↖																																																																									
Serie		99.9																																																																									
Total		0.0																																																																									
11:	9.9	→																																																																									
12:	10.4x	↓																																																																									
13:	10.2x	↗																																																																									
14:	10.4x	→																																																																									
Serie		40.9																																																																									
Total		0.0																																																																									
<b>60 Skott</b> 	<table style="width:100%; border-collapse: collapse;"> <tr><td>1:</td><td>10.6x</td><td>↗</td></tr> <tr><td>2:</td><td>10.8x</td><td>→</td></tr> <tr><td>3:</td><td>9.9</td><td>↘</td></tr> <tr><td>4:</td><td>10.6x</td><td>↗</td></tr> <tr><td>5:</td><td>10.0</td><td>→</td></tr> <tr><td>6:</td><td>10.6x</td><td>↗</td></tr> <tr><td>7:</td><td>9.9</td><td>↗</td></tr> <tr><td>8:</td><td>10.4x</td><td>←</td></tr> <tr><td>9:</td><td>9.8</td><td>↙</td></tr> <tr><td>10:</td><td>10.2x</td><td>→</td></tr> <tr><td colspan="2">Serie</td><td>102.8</td></tr> <tr><td colspan="2">Total</td><td>102.8</td></tr> </table>	1:	10.6x	↗	2:	10.8x	→	3:	9.9	↘	4:	10.6x	↗	5:	10.0	→	6:	10.6x	↗	7:	9.9	↗	8:	10.4x	←	9:	9.8	↙	10:	10.2x	→	Serie		102.8	Total		102.8	<b>60 Skott</b> 	<table style="width:100%; border-collapse: collapse;"> <tr><td>11:</td><td>9.5</td><td>→</td></tr> <tr><td>12:</td><td>10.5x</td><td>↓</td></tr> <tr><td>13:</td><td>10.9x</td><td>↗</td></tr> <tr><td>14:</td><td>10.5x</td><td>↘</td></tr> <tr><td>15:</td><td>10.1</td><td>↗</td></tr> <tr><td>16:</td><td>10.2x</td><td>←</td></tr> <tr><td>17:</td><td>9.9</td><td>↘</td></tr> <tr><td>18:</td><td>10.6x</td><td>↗</td></tr> <tr><td>19:</td><td>10.8x</td><td>↗</td></tr> <tr><td>20:</td><td>10.3x</td><td>↘</td></tr> <tr><td colspan="2">Serie</td><td>103.3</td></tr> <tr><td colspan="2">Total</td><td>206.1</td></tr> </table>	11:	9.5	→	12:	10.5x	↓	13:	10.9x	↗	14:	10.5x	↘	15:	10.1	↗	16:	10.2x	←	17:	9.9	↘	18:	10.6x	↗	19:	10.8x	↗	20:	10.3x	↘	Serie		103.3	Total		206.1
1:	10.6x	↗																																																																									
2:	10.8x	→																																																																									
3:	9.9	↘																																																																									
4:	10.6x	↗																																																																									
5:	10.0	→																																																																									
6:	10.6x	↗																																																																									
7:	9.9	↗																																																																									
8:	10.4x	←																																																																									
9:	9.8	↙																																																																									
10:	10.2x	→																																																																									
Serie		102.8																																																																									
Total		102.8																																																																									
11:	9.5	→																																																																									
12:	10.5x	↓																																																																									
13:	10.9x	↗																																																																									
14:	10.5x	↘																																																																									
15:	10.1	↗																																																																									
16:	10.2x	←																																																																									
17:	9.9	↘																																																																									
18:	10.6x	↗																																																																									
19:	10.8x	↗																																																																									
20:	10.3x	↘																																																																									
Serie		103.3																																																																									
Total		206.1																																																																									
<b>60 Skott</b> 	<table style="width:100%; border-collapse: collapse;"> <tr><td>21:</td><td>10.2x</td><td>↑</td></tr> <tr><td>22:</td><td>10.3x</td><td>↑</td></tr> <tr><td>23:</td><td>9.5</td><td>↙</td></tr> <tr><td>24:</td><td>9.7</td><td>↗</td></tr> <tr><td>25:</td><td>9.6</td><td>↙</td></tr> <tr><td>26:</td><td>10.0</td><td>↘</td></tr> <tr><td>27:</td><td>10.7x</td><td>↗</td></tr> <tr><td>28:</td><td>10.5x</td><td>←</td></tr> <tr><td>29:</td><td>10.1</td><td>↙</td></tr> <tr><td>30:</td><td>10.3x</td><td>↗</td></tr> <tr><td colspan="2">Serie</td><td>100.9</td></tr> <tr><td colspan="2">Total</td><td>307.0</td></tr> </table>	21:	10.2x	↑	22:	10.3x	↑	23:	9.5	↙	24:	9.7	↗	25:	9.6	↙	26:	10.0	↘	27:	10.7x	↗	28:	10.5x	←	29:	10.1	↙	30:	10.3x	↗	Serie		100.9	Total		307.0	<b>60 Skott</b> 	<table style="width:100%; border-collapse: collapse;"> <tr><td>31:</td><td>10.3x</td><td>↖</td></tr> <tr><td>32:</td><td>10.6x</td><td>↗</td></tr> <tr><td>33:</td><td>10.2x</td><td>↗</td></tr> <tr><td>34:</td><td>10.3x</td><td>←</td></tr> <tr><td>35:</td><td>10.3x</td><td>↙</td></tr> <tr><td>36:</td><td>10.7x</td><td>↘</td></tr> <tr><td>37:</td><td>10.2x</td><td>↘</td></tr> <tr><td>38:</td><td>10.7x</td><td>←</td></tr> <tr><td>39:</td><td>10.1</td><td>↖</td></tr> <tr><td>40:</td><td>10.1</td><td>↗</td></tr> <tr><td colspan="2">Serie</td><td>103.5</td></tr> <tr><td colspan="2">Total</td><td>410.5</td></tr> </table>	31:	10.3x	↖	32:	10.6x	↗	33:	10.2x	↗	34:	10.3x	←	35:	10.3x	↙	36:	10.7x	↘	37:	10.2x	↘	38:	10.7x	←	39:	10.1	↖	40:	10.1	↗	Serie		103.5	Total		410.5
21:	10.2x	↑																																																																									
22:	10.3x	↑																																																																									
23:	9.5	↙																																																																									
24:	9.7	↗																																																																									
25:	9.6	↙																																																																									
26:	10.0	↘																																																																									
27:	10.7x	↗																																																																									
28:	10.5x	←																																																																									
29:	10.1	↙																																																																									
30:	10.3x	↗																																																																									
Serie		100.9																																																																									
Total		307.0																																																																									
31:	10.3x	↖																																																																									
32:	10.6x	↗																																																																									
33:	10.2x	↗																																																																									
34:	10.3x	←																																																																									
35:	10.3x	↙																																																																									
36:	10.7x	↘																																																																									
37:	10.2x	↘																																																																									
38:	10.7x	←																																																																									
39:	10.1	↖																																																																									
40:	10.1	↗																																																																									
Serie		103.5																																																																									
Total		410.5																																																																									
<b>60 Skott</b> 	<table style="width:100%; border-collapse: collapse;"> <tr><td>41:</td><td>9.9</td><td>↑</td></tr> <tr><td>42:</td><td>10.9x</td><td>→</td></tr> <tr><td>43:</td><td>10.3x</td><td>→</td></tr> <tr><td>44:</td><td>10.5x</td><td>↗</td></tr> <tr><td>45:</td><td>10.0</td><td>→</td></tr> <tr><td>46:</td><td>10.0</td><td>↙</td></tr> <tr><td>47:</td><td>9.9</td><td>→</td></tr> <tr><td>48:</td><td>10.4x</td><td>←</td></tr> <tr><td>49:</td><td>10.8x</td><td>→</td></tr> <tr><td>50:</td><td>10.7x</td><td>↗</td></tr> <tr><td colspan="2">Serie</td><td>103.4</td></tr> <tr><td colspan="2">Total</td><td>513.9</td></tr> </table>	41:	9.9	↑	42:	10.9x	→	43:	10.3x	→	44:	10.5x	↗	45:	10.0	→	46:	10.0	↙	47:	9.9	→	48:	10.4x	←	49:	10.8x	→	50:	10.7x	↗	Serie		103.4	Total		513.9	<b>60 Skott</b> 	<table style="width:100%; border-collapse: collapse;"> <tr><td>51:</td><td>10.0</td><td>↑</td></tr> <tr><td>52:</td><td>10.2x</td><td>↖</td></tr> <tr><td>53:</td><td>10.0</td><td>↖</td></tr> <tr><td>54:</td><td>10.7x</td><td>↗</td></tr> <tr><td>55:</td><td>10.6x</td><td>↘</td></tr> <tr><td>56:</td><td>10.1</td><td>↗</td></tr> <tr><td>57:</td><td>10.4x</td><td>←</td></tr> <tr><td>58:</td><td>9.9</td><td>←</td></tr> <tr><td>59:</td><td>10.3x</td><td>→</td></tr> <tr><td>60:</td><td>10.3x</td><td>↙</td></tr> <tr><td colspan="2">Serie</td><td>102.5</td></tr> <tr><td colspan="2">Total</td><td>616.4</td></tr> </table>	51:	10.0	↑	52:	10.2x	↖	53:	10.0	↖	54:	10.7x	↗	55:	10.6x	↘	56:	10.1	↗	57:	10.4x	←	58:	9.9	←	59:	10.3x	→	60:	10.3x	↙	Serie		102.5	Total		616.4
41:	9.9	↑																																																																									
42:	10.9x	→																																																																									
43:	10.3x	→																																																																									
44:	10.5x	↗																																																																									
45:	10.0	→																																																																									
46:	10.0	↙																																																																									
47:	9.9	→																																																																									
48:	10.4x	←																																																																									
49:	10.8x	→																																																																									
50:	10.7x	↗																																																																									
Serie		103.4																																																																									
Total		513.9																																																																									
51:	10.0	↑																																																																									
52:	10.2x	↖																																																																									
53:	10.0	↖																																																																									
54:	10.7x	↗																																																																									
55:	10.6x	↘																																																																									
56:	10.1	↗																																																																									
57:	10.4x	←																																																																									
58:	9.9	←																																																																									
59:	10.3x	→																																																																									
60:	10.3x	↙																																																																									
Serie		102.5																																																																									
Total		616.4																																																																									



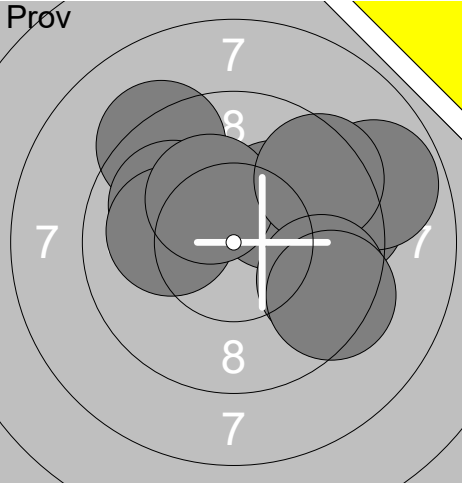
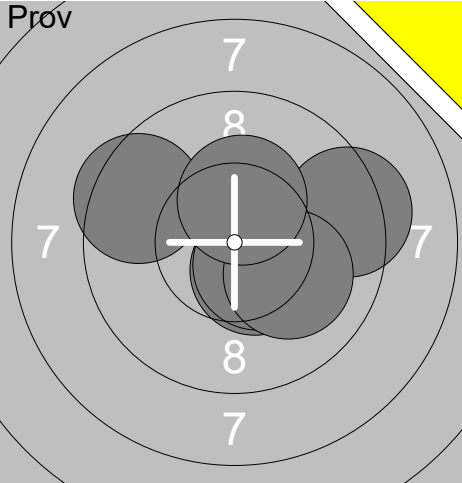
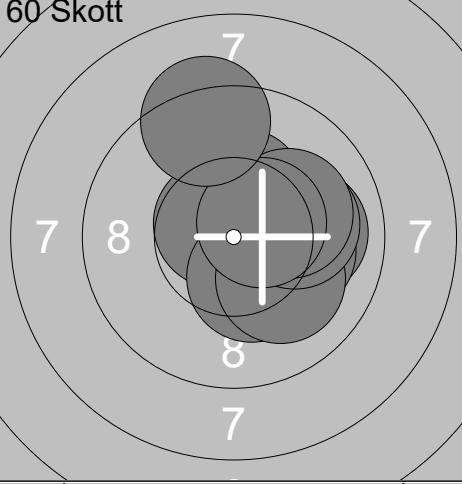
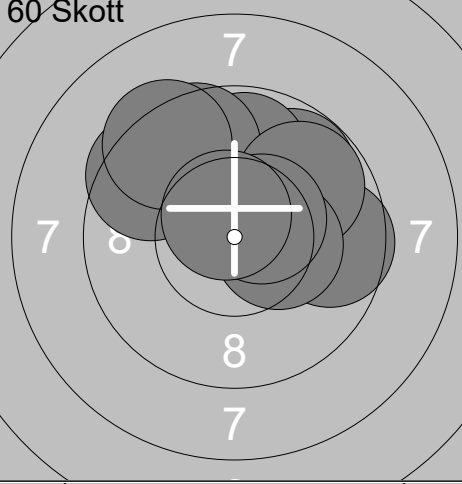
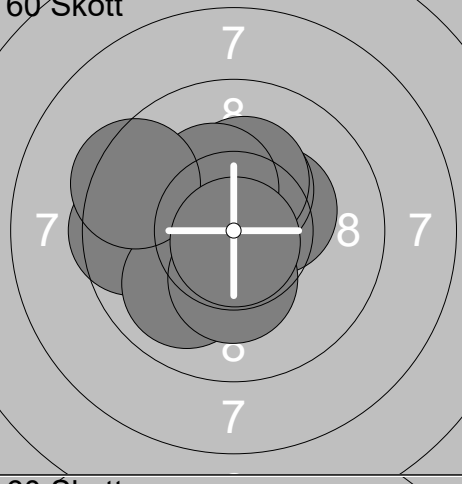
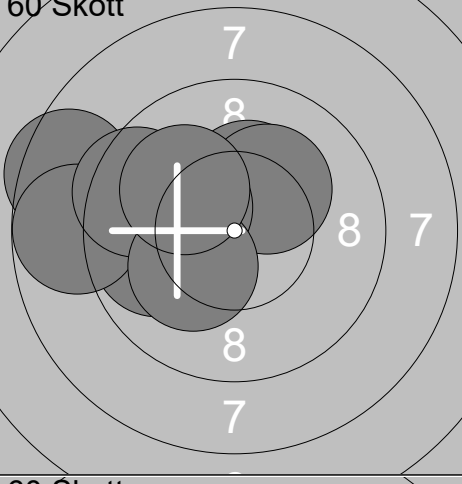
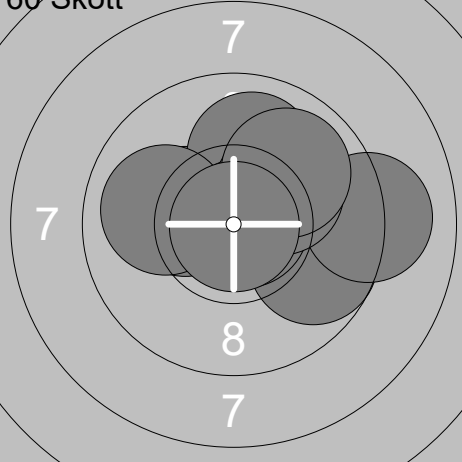
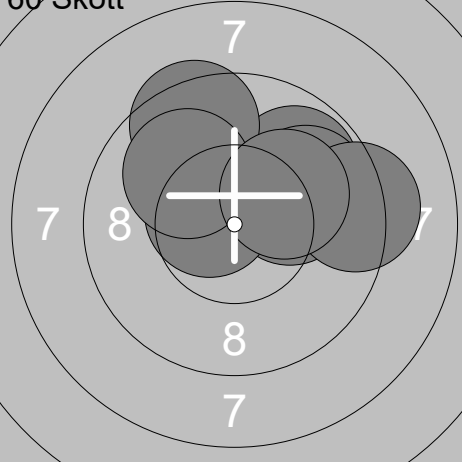

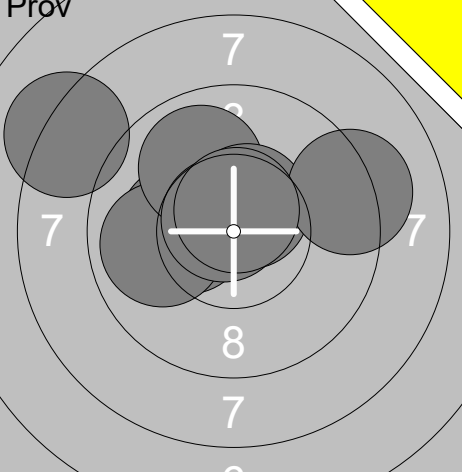
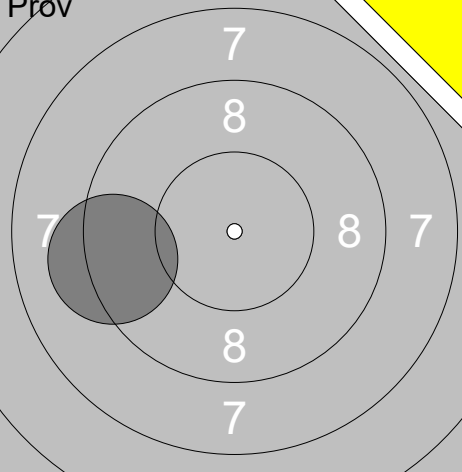
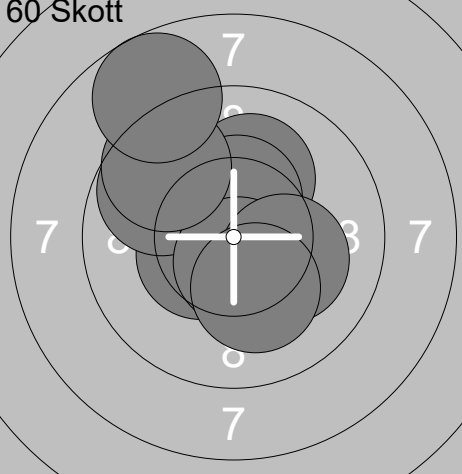
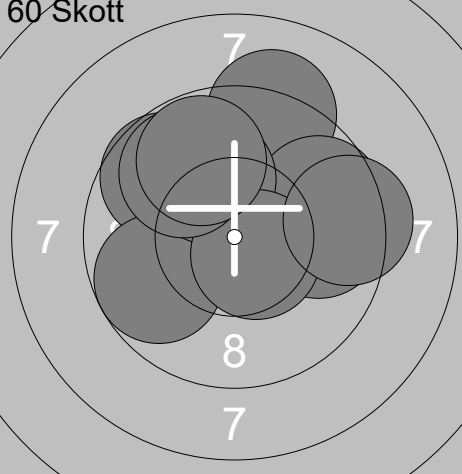
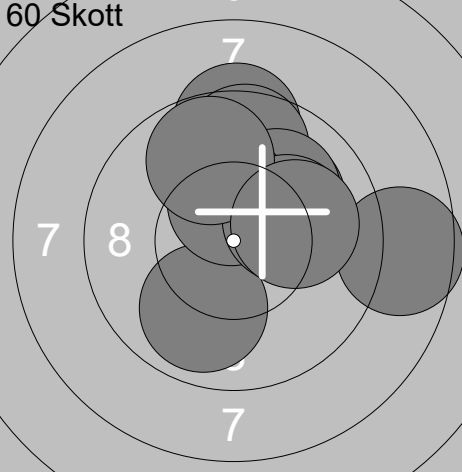
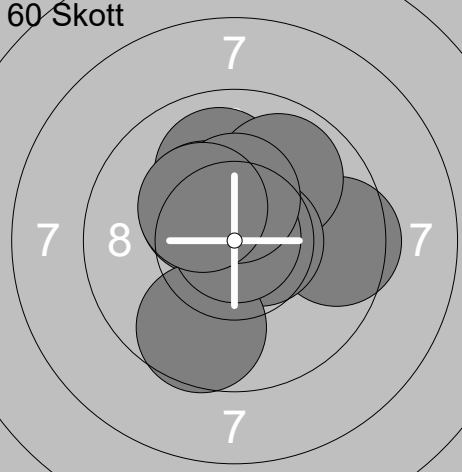
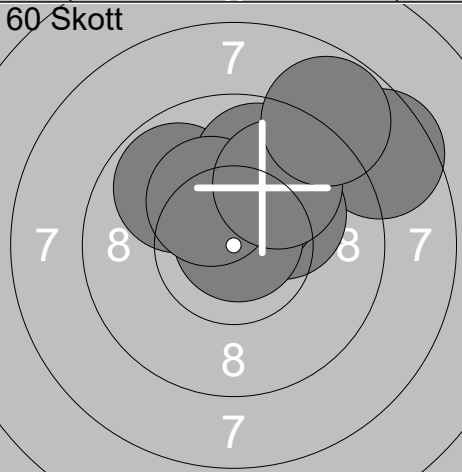
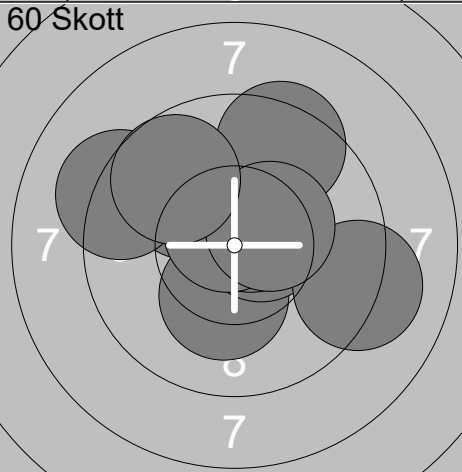

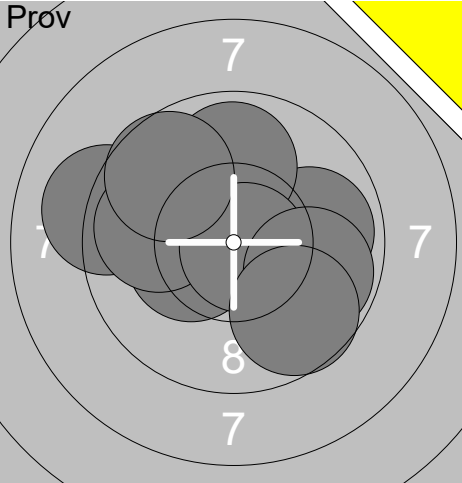
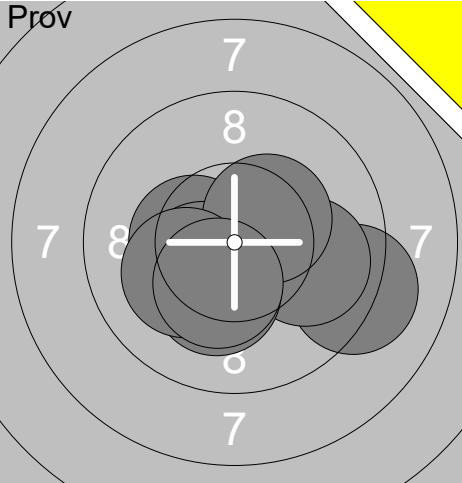
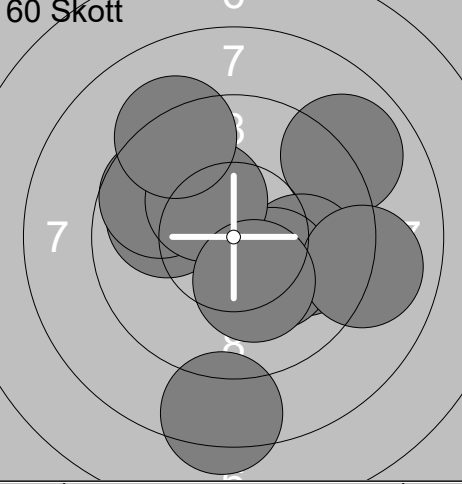
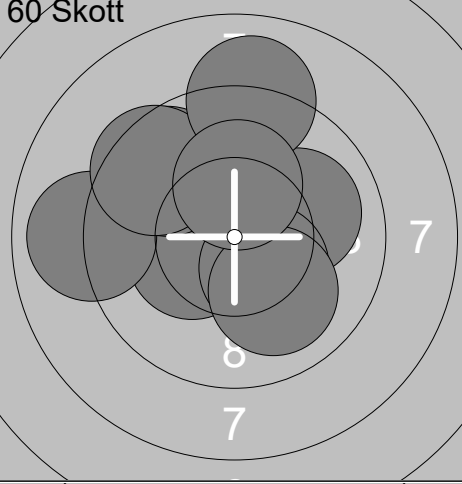
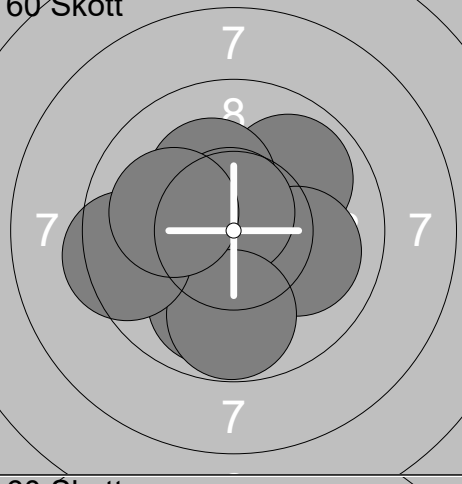
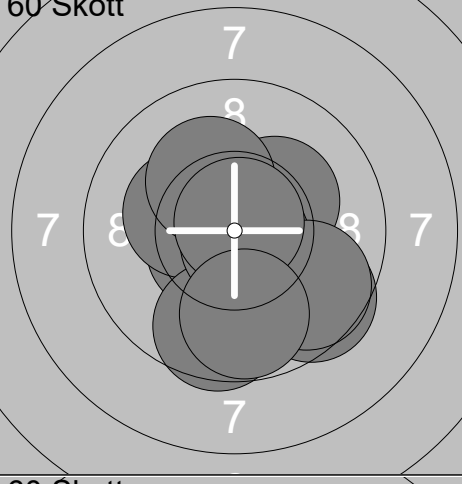
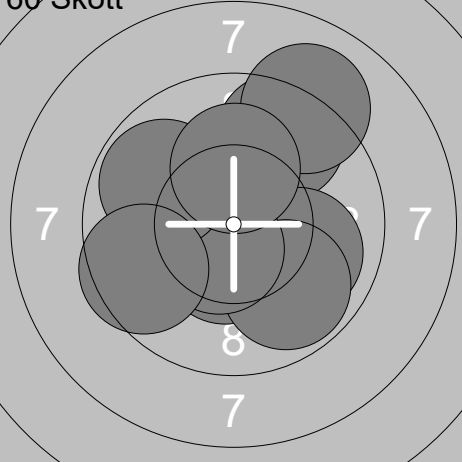
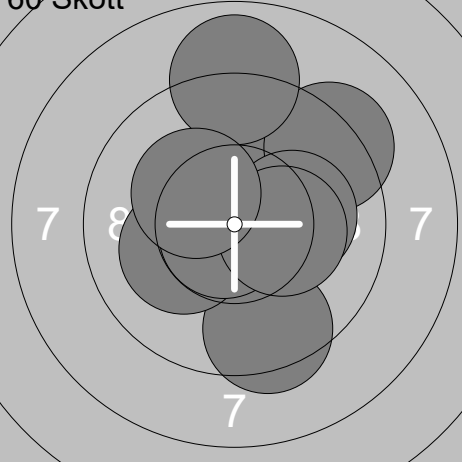
Skjutlag	Tavla	Tomas Hed			
2	5	Ramselefors	Forsa	Sen	Gä
03.11.2019	Vindelnskyttet 2019	Ramselefors SKF			
<b>Prov</b> 	1: 9.3 ↗ 2: 10.0 ↗ 3: 9.4 → 4: 8.8 → 5: 10.1 ← 6: 10.2x ↗ 7: 10.3x ↗ 8: 9.5 ↗ 9: 9.6 ↘ 10: 9.4 ↘ Serie 96.6 Total 0.0	<b>Prov</b> 	11: 10.5x ↘ 12: 10.5x ↘ 13: 9.3 → 14: 10.1 ↘ 15: 9.5 ← 16: 10.3x ↑ Serie 60.2 Total 0.0		
<b>60 Skott</b> 	1: 10.0 → 2: 10.3x ↑ 3: 10.7x ↗ 4: 10.1 ↘ 5: 10.3x ↘ 6: 10.1 ↘ 7: 10.1 → 8: 10.1 → 9: 10.5x ↗ 10: 9.3 ↑ Serie 101.5 Total 101.5	<b>60 Skott</b> 	11: 9.6 → 12: 9.5 ↗ 13: 9.8 ↗ 14: 9.8 ↑ 15: 9.6 ↑ 16: 9.8 ↗ 17: 10.3x → 18: 9.4 ↗ 19: 10.5x ↗ 20: 10.6x ↑ Serie 98.9 Total 200.4		
<b>60 Skott</b> 	21: 10.9x ↗ 22: 10.3x ↗ 23: 9.6 ← 24: 10.4x ↑ 25: 10.2x ↑ 26: 10.0 ↘ 27: 10.3x ↘ 28: 10.3x ↗ 29: 9.4 ← 30: 10.8x ↘ Serie 102.2 Total 302.6	<b>60 Skott</b> 	31: 8.5 ↗ 32: 10.0 ↗ 33: 10.3x ↑ 34: 9.8 ← 35: 8.8 ← 36: 10.2x ↗ 37: 10.2x ↗ 38: 9.5 ↗ 39: 10.2x ↘ 40: 10.1 ↗ Serie 97.6 Total 400.2		
<b>60 Skott</b> 	41: 10.3x ← 42: 9.7 ↘ 43: 10.7x ↑ 44: 9.1 → 45: 10.0 ↑ 46: 10.8x → 47: 10.2x ↗ 48: 10.0 ← 49: 9.9 ↗ 50: 10.9x ↘ Serie 101.6 Total 501.8	<b>60 Skott</b> 	51: 9.8 ↗ 52: 10.2x ↗ 53: 10.1 ↗ 54: 9.8 ↗ 55: 9.5 ↑ 56: 10.1 → 57: 10.6x ↗ 58: 9.2 → 59: 10.0 ↗ 60: 10.1 ↗ Serie 99.4 Total 601.2		

<b>Prov</b> 	1: 10.3x ← 2: 10.2x ← 3: 9.9 ← 4: 10.6x ↑ 5: 9.9 ↑ 6: 10.7x ↑ 7: 10.5x ↑ 8: 9.2 → 9: 8.2 ↖ 10: 10.6x ↑ <hr/> Serie 100.1 Total 0.0	<b>Prov</b> 	11: 9.2 ← <hr/> Serie 9.2 Total 0.0
<b>60 Skott</b> 	1: 10.1 ↑ 2: 10.4x ← 3: 9.8 ↖ 4: 10.3x ↘ 5: 10.4x ↑ 6: 10.6x ↘ 7: 9.6 ↖ 8: 8.7 ↖ 9: 10.2x → 10: 10.2x ↘ <hr/> Serie 100.3 Total 100.3	<b>60 Skott</b> 	11: 9.7 ↖ 12: 9.2 ↑ 13: 9.8 → 14: 9.7 → 15: 9.7 ← 16: 10.1 ↖ 17: 10.6x ↘ 18: 9.8 ↖ 19: 9.4 → 20: 9.8 ↖ <hr/> Serie 97.8 Total 198.1
<b>60 Skott</b> 	21: 9.9 ↘ 22: 9.4 ↑ 23: 9.6 ↑ 24: 8.6 → 25: 10.1 ↖ 26: 10.0 ↖ 27: 10.4x ↑ 28: 10.2x → 29: 9.8 ↑ 30: 10.1 → <hr/> Serie 98.1 Total 296.2	<b>60 Skott</b> 	31: 10.0 ↑ 32: 10.4x ↖ 33: 9.5 → 34: 9.9 ↖ 35: 10.6x → 36: 9.7 ↘ 37: 10.9x ↖ 38: 10.3x ↖ 39: 10.4x ↑ 40: 10.3x ↖ <hr/> Serie 102.0 Total 398.2
<b>60 Skott</b> 	41: 8.6 ↖ 42: 10.2x ↑ 43: 9.8 ↖ 44: 9.8 ↑ 45: 10.2x ↖ 46: 10.3x ↖ 47: 10.8x ↖ 48: 10.3x ↖ 49: 9.9 ↖ 50: 8.8 ↖ <hr/> Serie 98.7 Total 496.9	<b>60 Skott</b> 	51: 10.0 ↖ 52: 10.2x ↘ 53: 10.6x → 54: 9.1 → 55: 10.6x ↖ 56: 10.7x ↖ 57: 9.4 ↖ 58: 10.4x → 59: 9.2 ← 60: 9.7 ↖ <hr/> Serie 99.9 Total 596.8

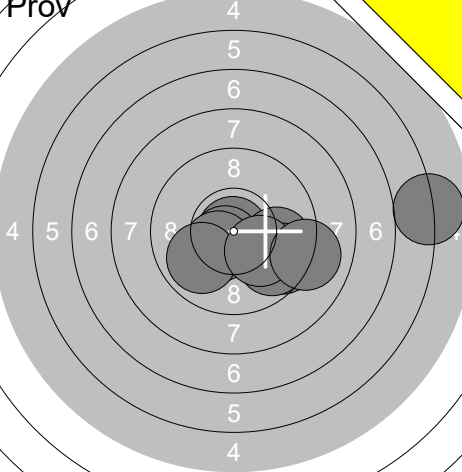
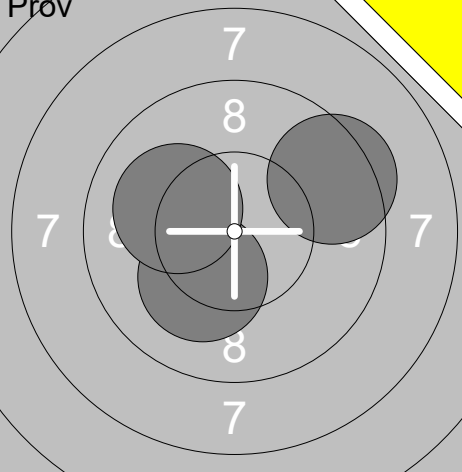
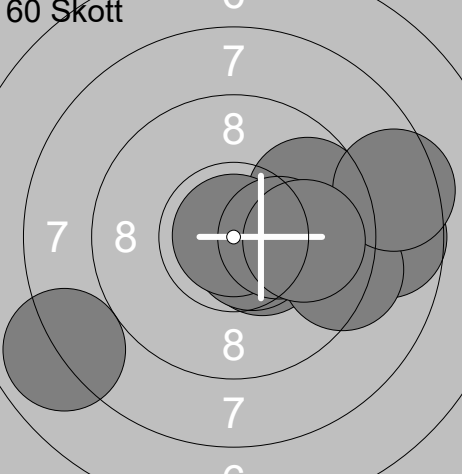
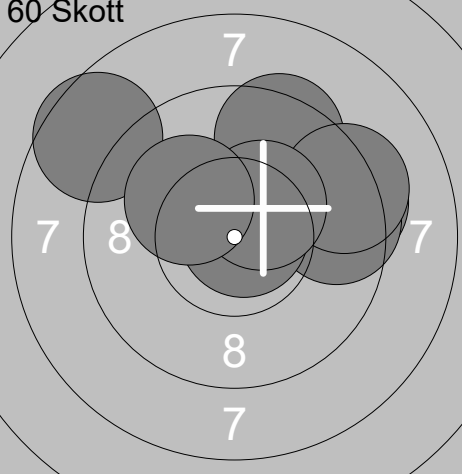
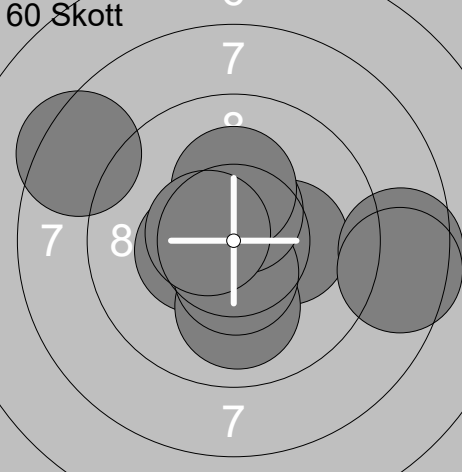
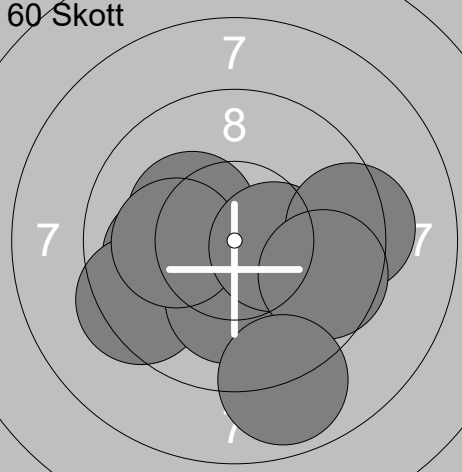
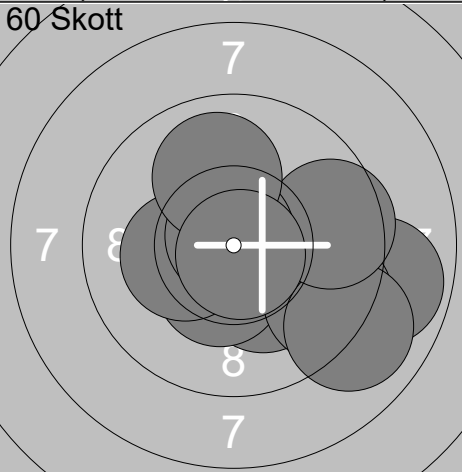
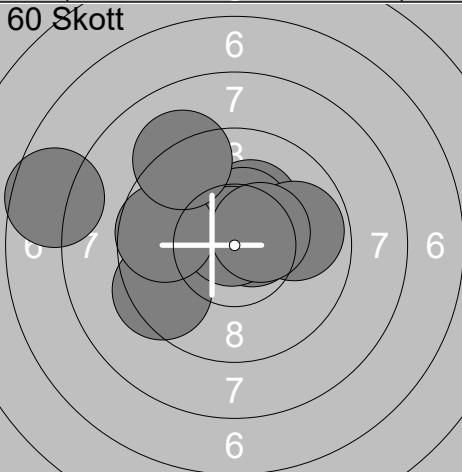
Skjuttag	Tavla	Beatrice Andersson			
2	7	Ramselefors	Ramselefors	15S	Vb
03.11.2019	Vindelnskyttet 2019	Ramselefors SKF			
<b>Pröv</b> 	1: 9.9 → 2: 9.1 ← 3: 10.4x ↗ 4: 10.3x ← 5: 9.9 ← 6: 9.9 ↑ 7: 10.8x ↘ 8: 9.8 ↘ 9: 9.7 ↗ 10: 9.7 ↘ Serie 99.5 Total 0.0	<b>Pröv</b> 	11: 9.2 → 12: 9.9 → 13: 10.4x ← 14: 10.4x ↙ 15: 10.4x ↗ 16: 10.2x ↓ 17: 10.2x ← 18: 10.3x ↓ Serie 81.0 Total 0.0		
<b>60 Skott</b> 	1: 8.3 ↓ 2: 9.0 ↗ 3: 9.9 ← 4: 9.9 ↘ 5: 10.2x ↘ 6: 9.0 ↘ 7: 9.7 ↗ 8: 10.3x ↗ 9: 9.3 ↗ 10: 10.2x ↘ Serie 95.8 Total 95.8	<b>60 Skott</b> 	11: 10.8x ↑ 12: 10.3x ← 13: 10.0 → 14: 9.6 ↗ 15: 10.4x ↘ 16: 9.0 ← 17: 10.0 ↘ 18: 9.5 ↗ 19: 9.0 ↑ 20: 10.2x ↑ Serie 98.8 Total 194.6		
<b>60 Skott</b> 	21: 10.7x ↘ 22: 9.9 ↗ 23: 9.9 ↓ 24: 10.2x ← 25: 10.2x ↗ 26: 10.0 → 27: 10.7x ↑ 28: 9.8 ↓ 29: 9.4 ← 30: 10.1 ← Serie 100.9 Total 295.5	<b>60 Skott</b> 	31: 10.6x ↙ 32: 10.3x ↗ 33: 10.3x ← 34: 10.2x ↗ 35: 9.5 ↘ 36: 9.6 ↓ 37: 10.7x ↘ 38: 9.7 ↘ 39: 10.8x ↗ 40: 9.8 ↓ Serie 101.5 Total 397.0		
<b>60 Skott</b> 	41: 9.6 ↑ 42: 10.0 ↘ 43: 10.5x ↘ 44: 9.8 ↘ 45: 10.1 ↗ 46: 10.6x ↘ 47: 9.8 ↗ 48: 9.1 ↗ 49: 9.6 ← 50: 10.2x ↑ Serie 99.3 Total 496.3	<b>60 Skott</b> 	51: 10.5x ↑ 52: 9.4 ↓ 53: 10.3x ↑ 54: 10.2x ← 55: 9.3 ↗ 56: 10.1 → 57: 10.8x ↙ 58: 8.9 ↑ 59: 10.3x → 60: 10.3x ↙ Serie 100.1 Total 596.4		

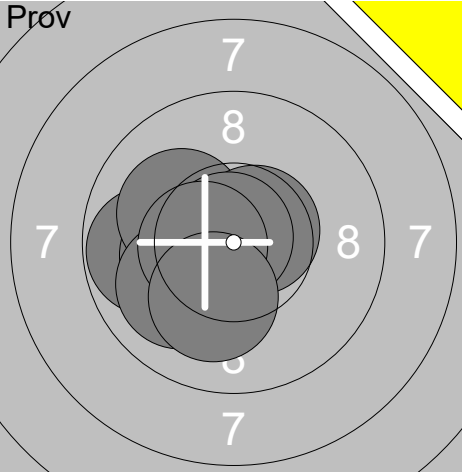
<p><b>Prov</b></p>	<table border="1" style="width:100%; border-collapse: collapse;"> <tr><td>1:</td><td>9.6</td><td>↗</td></tr> <tr><td>2:</td><td>10.4x</td><td>↖</td></tr> <tr><td>3:</td><td>10.6x</td><td>↖</td></tr> <tr><td>4:</td><td>10.6x</td><td>↖</td></tr> <tr><td>5:</td><td>9.9</td><td>↗</td></tr> <tr><td>6:</td><td>9.2</td><td>↗</td></tr> <tr><td>7:</td><td>9.7</td><td>↗</td></tr> <tr><td>8:</td><td>9.5</td><td>↘</td></tr> <tr><td>9:</td><td>10.7x</td><td>↗</td></tr> <tr><td>10:</td><td>10.4x</td><td>↖</td></tr> <tr><td colspan="2"><b>Serie</b></td><td><b>100.6</b></td></tr> <tr><td colspan="2"><b>Total</b></td><td><b>0.0</b></td></tr> </table>	1:	9.6	↗	2:	10.4x	↖	3:	10.6x	↖	4:	10.6x	↖	5:	9.9	↗	6:	9.2	↗	7:	9.7	↗	8:	9.5	↘	9:	10.7x	↗	10:	10.4x	↖	<b>Serie</b>		<b>100.6</b>	<b>Total</b>		<b>0.0</b>	<p><b>60 Skott</b></p>	<table border="1" style="width:100%; border-collapse: collapse;"> <tr><td>1:</td><td>9.6</td><td>↘</td></tr> <tr><td>2:</td><td>10.4x</td><td>↗</td></tr> <tr><td>3:</td><td>10.4x</td><td>↘</td></tr> <tr><td>4:</td><td>10.1</td><td>↘</td></tr> <tr><td>5:</td><td>9.1</td><td>↖</td></tr> <tr><td>6:</td><td>10.3x</td><td>↗</td></tr> <tr><td>7:</td><td>10.2x</td><td>↖</td></tr> <tr><td>8:</td><td>9.6</td><td>↖</td></tr> <tr><td>9:</td><td>9.7</td><td>↖</td></tr> <tr><td>10:</td><td>10.5x</td><td>↘</td></tr> <tr><td colspan="2"><b>Serie</b></td><td><b>99.9</b></td></tr> <tr><td colspan="2"><b>Total</b></td><td><b>99.9</b></td></tr> </table>	1:	9.6	↘	2:	10.4x	↗	3:	10.4x	↘	4:	10.1	↘	5:	9.1	↖	6:	10.3x	↗	7:	10.2x	↖	8:	9.6	↖	9:	9.7	↖	10:	10.5x	↘	<b>Serie</b>		<b>99.9</b>	<b>Total</b>		<b>99.9</b>
1:	9.6	↗																																																																									
2:	10.4x	↖																																																																									
3:	10.6x	↖																																																																									
4:	10.6x	↖																																																																									
5:	9.9	↗																																																																									
6:	9.2	↗																																																																									
7:	9.7	↗																																																																									
8:	9.5	↘																																																																									
9:	10.7x	↗																																																																									
10:	10.4x	↖																																																																									
<b>Serie</b>		<b>100.6</b>																																																																									
<b>Total</b>		<b>0.0</b>																																																																									
1:	9.6	↘																																																																									
2:	10.4x	↗																																																																									
3:	10.4x	↘																																																																									
4:	10.1	↘																																																																									
5:	9.1	↖																																																																									
6:	10.3x	↗																																																																									
7:	10.2x	↖																																																																									
8:	9.6	↖																																																																									
9:	9.7	↖																																																																									
10:	10.5x	↘																																																																									
<b>Serie</b>		<b>99.9</b>																																																																									
<b>Total</b>		<b>99.9</b>																																																																									
<p><b>60 Skott</b></p>	<table border="1" style="width:100%; border-collapse: collapse;"> <tr><td>11:</td><td>10.4x</td><td>↗</td></tr> <tr><td>12:</td><td>10.1</td><td>↗</td></tr> <tr><td>13:</td><td>9.7</td><td>↗</td></tr> <tr><td>14:</td><td>10.1</td><td>↗</td></tr> <tr><td>15:</td><td>9.2</td><td>↗</td></tr> <tr><td>16:</td><td>9.7</td><td>↖</td></tr> <tr><td>17:</td><td>10.6x</td><td>↘</td></tr> <tr><td>18:</td><td>10.8x</td><td>↗</td></tr> <tr><td>19:</td><td>9.9</td><td>↖</td></tr> <tr><td>20:</td><td>10.0</td><td>↗</td></tr> <tr><td colspan="2"><b>Serie</b></td><td><b>100.5</b></td></tr> <tr><td colspan="2"><b>Total</b></td><td><b>200.4</b></td></tr> </table>	11:	10.4x	↗	12:	10.1	↗	13:	9.7	↗	14:	10.1	↗	15:	9.2	↗	16:	9.7	↖	17:	10.6x	↘	18:	10.8x	↗	19:	9.9	↖	20:	10.0	↗	<b>Serie</b>		<b>100.5</b>	<b>Total</b>		<b>200.4</b>	<p><b>60 Skott</b></p>	<table border="1" style="width:100%; border-collapse: collapse;"> <tr><td>21:</td><td>10.2x</td><td>↘</td></tr> <tr><td>22:</td><td>10.2x</td><td>↖</td></tr> <tr><td>23:</td><td>10.1</td><td>↗</td></tr> <tr><td>24:</td><td>10.2x</td><td>↖</td></tr> <tr><td>25:</td><td>9.5</td><td>↗</td></tr> <tr><td>26:</td><td>10.4x</td><td>↗</td></tr> <tr><td>27:</td><td>10.8x</td><td>↗</td></tr> <tr><td>28:</td><td>10.1</td><td>↗</td></tr> <tr><td>29:</td><td>9.4</td><td>↗</td></tr> <tr><td>30:</td><td>8.6</td><td>↖</td></tr> <tr><td colspan="2"><b>Serie</b></td><td><b>99.5</b></td></tr> <tr><td colspan="2"><b>Total</b></td><td><b>299.9</b></td></tr> </table>	21:	10.2x	↘	22:	10.2x	↖	23:	10.1	↗	24:	10.2x	↖	25:	9.5	↗	26:	10.4x	↗	27:	10.8x	↗	28:	10.1	↗	29:	9.4	↗	30:	8.6	↖	<b>Serie</b>		<b>99.5</b>	<b>Total</b>		<b>299.9</b>
11:	10.4x	↗																																																																									
12:	10.1	↗																																																																									
13:	9.7	↗																																																																									
14:	10.1	↗																																																																									
15:	9.2	↗																																																																									
16:	9.7	↖																																																																									
17:	10.6x	↘																																																																									
18:	10.8x	↗																																																																									
19:	9.9	↖																																																																									
20:	10.0	↗																																																																									
<b>Serie</b>		<b>100.5</b>																																																																									
<b>Total</b>		<b>200.4</b>																																																																									
21:	10.2x	↘																																																																									
22:	10.2x	↖																																																																									
23:	10.1	↗																																																																									
24:	10.2x	↖																																																																									
25:	9.5	↗																																																																									
26:	10.4x	↗																																																																									
27:	10.8x	↗																																																																									
28:	10.1	↗																																																																									
29:	9.4	↗																																																																									
30:	8.6	↖																																																																									
<b>Serie</b>		<b>99.5</b>																																																																									
<b>Total</b>		<b>299.9</b>																																																																									
<p><b>60 Skott</b></p>	<table border="1" style="width:100%; border-collapse: collapse;"> <tr><td>31:</td><td>10.1</td><td>↗</td></tr> <tr><td>32:</td><td>9.6</td><td>↖</td></tr> <tr><td>33:</td><td>9.9</td><td>↘</td></tr> <tr><td>34:</td><td>9.8</td><td>↘</td></tr> <tr><td>35:</td><td>9.5</td><td>↗</td></tr> <tr><td>36:</td><td>10.0</td><td>↗</td></tr> <tr><td>37:</td><td>7.4</td><td>↗</td></tr> <tr><td>38:</td><td>10.4x</td><td>↗</td></tr> <tr><td>39:</td><td>9.6</td><td>↖</td></tr> <tr><td>40:</td><td>9.7</td><td>↖</td></tr> <tr><td colspan="2"><b>Serie</b></td><td><b>96.0</b></td></tr> <tr><td colspan="2"><b>Total</b></td><td><b>395.9</b></td></tr> </table>	31:	10.1	↗	32:	9.6	↖	33:	9.9	↘	34:	9.8	↘	35:	9.5	↗	36:	10.0	↗	37:	7.4	↗	38:	10.4x	↗	39:	9.6	↖	40:	9.7	↖	<b>Serie</b>		<b>96.0</b>	<b>Total</b>		<b>395.9</b>	<p><b>60 Skott</b></p>	<table border="1" style="width:100%; border-collapse: collapse;"> <tr><td>41:</td><td>10.0</td><td>↗</td></tr> <tr><td>42:</td><td>10.5x</td><td>↗</td></tr> <tr><td>43:</td><td>9.4</td><td>↖</td></tr> <tr><td>44:</td><td>9.2</td><td>↗</td></tr> <tr><td>45:</td><td>10.3x</td><td>↘</td></tr> <tr><td>46:</td><td>9.6</td><td>↖</td></tr> <tr><td>47:</td><td>10.5x</td><td>↘</td></tr> <tr><td>48:</td><td>10.5x</td><td>↗</td></tr> <tr><td>49:</td><td>10.0</td><td>↗</td></tr> <tr><td>50:</td><td>9.8</td><td>↘</td></tr> <tr><td colspan="2"><b>Serie</b></td><td><b>99.8</b></td></tr> <tr><td colspan="2"><b>Total</b></td><td><b>495.7</b></td></tr> </table>	41:	10.0	↗	42:	10.5x	↗	43:	9.4	↖	44:	9.2	↗	45:	10.3x	↘	46:	9.6	↖	47:	10.5x	↘	48:	10.5x	↗	49:	10.0	↗	50:	9.8	↘	<b>Serie</b>		<b>99.8</b>	<b>Total</b>		<b>495.7</b>
31:	10.1	↗																																																																									
32:	9.6	↖																																																																									
33:	9.9	↘																																																																									
34:	9.8	↘																																																																									
35:	9.5	↗																																																																									
36:	10.0	↗																																																																									
37:	7.4	↗																																																																									
38:	10.4x	↗																																																																									
39:	9.6	↖																																																																									
40:	9.7	↖																																																																									
<b>Serie</b>		<b>96.0</b>																																																																									
<b>Total</b>		<b>395.9</b>																																																																									
41:	10.0	↗																																																																									
42:	10.5x	↗																																																																									
43:	9.4	↖																																																																									
44:	9.2	↗																																																																									
45:	10.3x	↘																																																																									
46:	9.6	↖																																																																									
47:	10.5x	↘																																																																									
48:	10.5x	↗																																																																									
49:	10.0	↗																																																																									
50:	9.8	↘																																																																									
<b>Serie</b>		<b>99.8</b>																																																																									
<b>Total</b>		<b>495.7</b>																																																																									
<p><b>60 Skott</b></p>	<table border="1" style="width:100%; border-collapse: collapse;"> <tr><td>51:</td><td>10.6x</td><td>↘</td></tr> <tr><td>52:</td><td>9.7</td><td>↗</td></tr> <tr><td>53:</td><td>10.9x</td><td>↖</td></tr> <tr><td>54:</td><td>9.5</td><td>↘</td></tr> <tr><td>55:</td><td>6.8</td><td>↗</td></tr> <tr><td>56:</td><td>10.5x</td><td>↗</td></tr> <tr><td>57:</td><td>9.8</td><td>↘</td></tr> <tr><td>58:</td><td>10.4x</td><td>↘</td></tr> <tr><td>59:</td><td>9.6</td><td>↗</td></tr> <tr><td>60:</td><td>10.7x</td><td>↗</td></tr> <tr><td colspan="2"><b>Serie</b></td><td><b>98.5</b></td></tr> <tr><td colspan="2"><b>Total</b></td><td><b>594.2</b></td></tr> </table>	51:	10.6x	↘	52:	9.7	↗	53:	10.9x	↖	54:	9.5	↘	55:	6.8	↗	56:	10.5x	↗	57:	9.8	↘	58:	10.4x	↘	59:	9.6	↗	60:	10.7x	↗	<b>Serie</b>		<b>98.5</b>	<b>Total</b>		<b>594.2</b>																																						
51:	10.6x	↘																																																																									
52:	9.7	↗																																																																									
53:	10.9x	↖																																																																									
54:	9.5	↘																																																																									
55:	6.8	↗																																																																									
56:	10.5x	↗																																																																									
57:	9.8	↘																																																																									
58:	10.4x	↘																																																																									
59:	9.6	↗																																																																									
60:	10.7x	↗																																																																									
<b>Serie</b>		<b>98.5</b>																																																																									
<b>Total</b>		<b>594.2</b>																																																																									

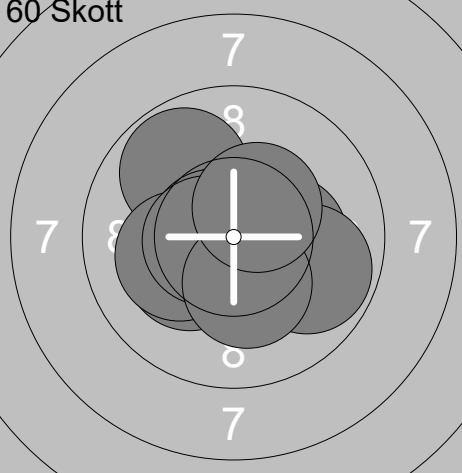
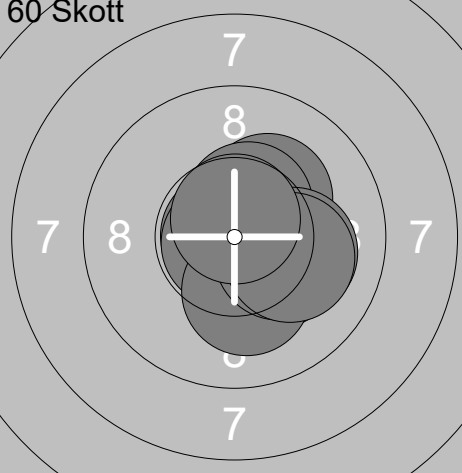
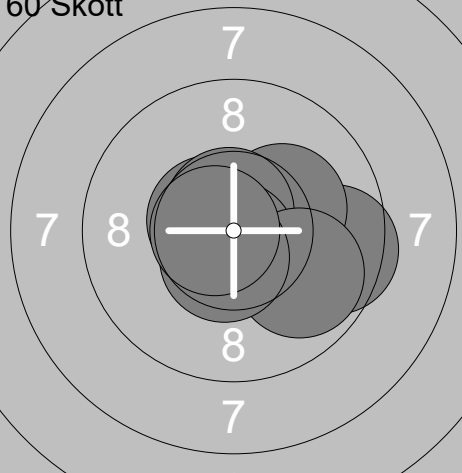
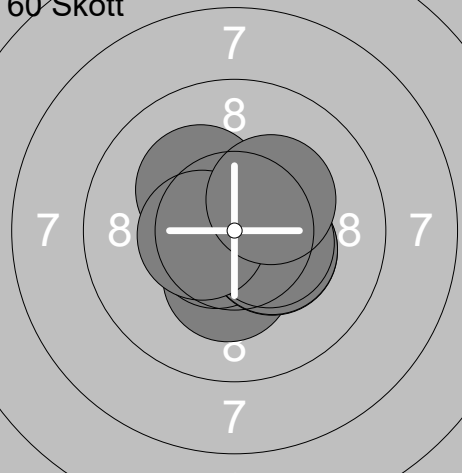
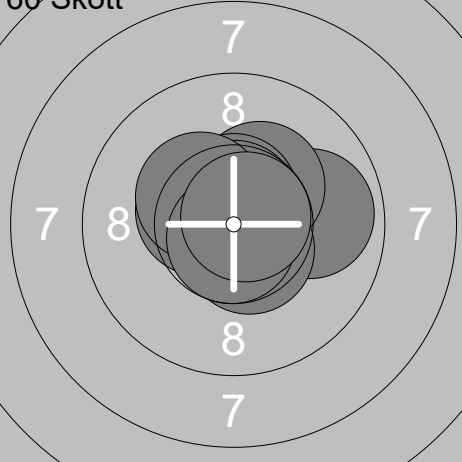
<b>Prov</b> 	1: 10.9x ↙ 2: 10.6x ↘ 3: 9.8 → 4: 10.4x ↘ 5: 6.0 → 6: 9.5 ↘ 7: 9.7 ↘ 8: 9.9 ↙ 9: 10.1 ↘ 10: 9.0 ↘ <hr/> Serie 95.9 Total 0.0	<b>Prov</b> 	11: 10.2x ↙ 12: 9.4 → 13: 10.1 ← <hr/> Serie 29.7 Total 0.0
<b>60 Skott</b> 	1: 7.9 ← 2: 10.5x ↘ 3: 10.6x ↘ 4: 8.7 → 5: 9.7 → 6: 10.9x ↑ 7: 9.3 → 8: 10.3x → 9: 8.5 → 10: 9.9 → <hr/> Serie 96.3 Total 96.3	<b>60 Skott</b> 	11: 9.4 → 12: 9.8 ↗ 13: 9.5 → 14: 10.2x ↗ 15: 9.4 ↗ 16: 10.8x → 17: 9.3 → 18: 8.6 ↖ 19: 10.4x ↗ 20: 10.1 ↖ <hr/> Serie 97.5 Total 193.8
<b>60 Skott</b> 	21: 10.2x → 22: 10.4x ← 23: 10.0 ↓ 24: 8.4 ↗ 25: 8.5 → 26: 10.5x ↓ 27: 8.5 → 28: 10.5x ↑ 29: 10.2x ↑ 30: 10.6x ← <hr/> Serie 97.8 Total 291.6	<b>60 Skott</b> 	31: 10.3x ↖ 32: 10.0 ← 33: 9.4 ← 34: 9.7 → 35: 10.1 ↓ 36: 10.1 ← 37: 10.4x → 38: 9.3 → 39: 9.6 → 40: 8.9 ↓ <hr/> Serie 97.8 Total 389.4
<b>60 Skott</b> 	41: 10.2x ↘ 42: 8.9 → 43: 10.4x ↘ 44: 9.4 ↘ 45: 10.3x ← 46: 9.0 ↘ 47: 9.6 → 48: 10.8x ↗ 49: 10.0 ↗ 50: 10.8x ↘ <hr/> Serie 99.4 Total 488.8	<b>60 Skott</b> 	51: 9.4 ← 52: 10.6x → 53: 10.3x ↗ 54: 10.4x ↗ 55: 10.8x ↗ 56: 7.6 ← 57: 9.8 → 58: 9.7 ← 59: 10.4x → 60: 9.2 ↗ <hr/> Serie 98.2 Total 587.0

Skjuttag	Tavla	Lotten Johansson					
2	11	Ramselefors	Ramselefors	Sen	Vb		
03.11.2019	Vindelnskyttet 2019	Ramselefors SKF					
<b>Prøv</b> 	1: 10.4x ← 2: 9.8 ← 3: 10.2x ← 4: 10.9x ↗ 5: 10.1 ↗ 6: 10.6x ↗ 7: 10.8x ↗ 8: 10.0 ↙ 9: 10.5x ← 10: 10.1 ↓	<b>Prøv</b> 	11: 10.5x ← 12: 10.4x →	Serie	103.4	Serie	20.9
	Total	0.0	Total	0.0			
<b>60 Skott</b> 	1: 10.2x ← 2: 9.8 ↗ 3: 10.3x → 4: 10.2x ← 5: 10.8x ↗ 6: 10.7x ← 7: 9.8 → 8: 10.6x ← 9: 10.3x ↓ 10: 10.4x ↗	<b>60 Skott</b> 	11: 10.2x ↗ 12: 10.5x ↗ 13: 10.8x ← 14: 10.3x ↘ 15: 10.8x ↙ 16: 10.2x ↓ 17: 10.3x → 18: 10.1 → 19: 10.1 → 20: 10.7x ↑	Serie	103.1	Serie	104.0
	Total	103.1	Total	207.1			
<b>60 Skott</b> 	21: 10.6x ← 22: 9.5 → 23: 10.9x ↙ 24: 10.8x ↙ 25: 10.2x ↗ 26: 10.7x ↗ 27: 10.8x ↓ 28: 9.9 ↘ 29: 10.6x ↓ 30: 10.7x ←	<b>60 Skott</b> 	31: 10.3x ↓ 32: 10.6x ↙ 33: 10.5x ↗ 34: 10.4x → 35: 10.4x ↘ 36: 10.8x ↗ 37: 10.2x ↗ 38: 10.4x → 39: 10.5x ← 40: 10.3x ↗	Serie	104.7	Serie	104.4
	Total	311.8	Total	416.2			
<b>60 Skott</b> 	41: 9.9 → 42: 10.3x ↗ 43: 10.8x ↙ 44: 10.6x ↑ 45: 10.7x ↑ 46: 10.4x ↗ 47: 10.5x ↘ 48: 10.4x ↗ 49: 10.7x ↓ 50: 10.8x ↗	<b>60 Skott</b> 	51: 10.3x ↗ 52: 10.2x ↑ 53: 10.4x ↑ 54: 10.7x ↙ 55: 10.8x ↘ 56: 10.2x ↑ 57: 10.1 ↑ 58: 9.4 ↗ 59: 10.5x ↑ 60: 10.3x ↗	Serie	105.1	Serie	102.9
	Total	521.3	Total	624.2			

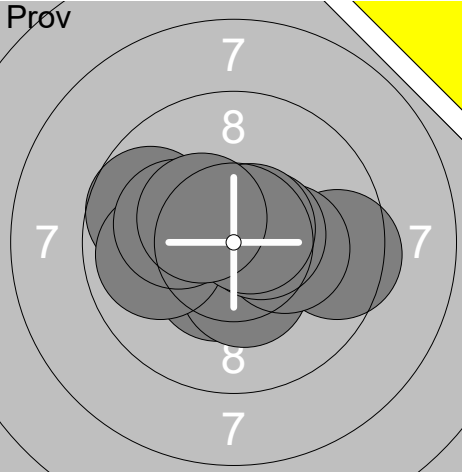
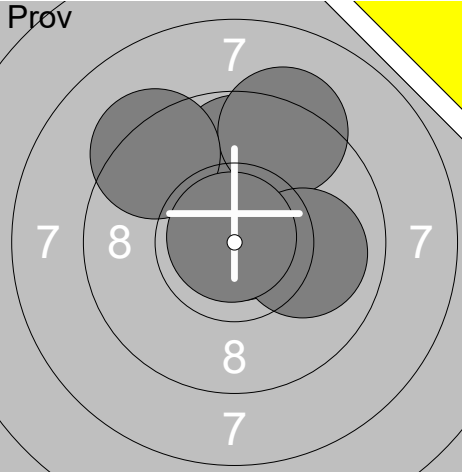
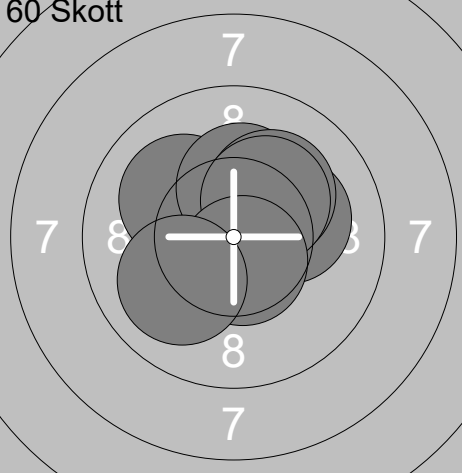
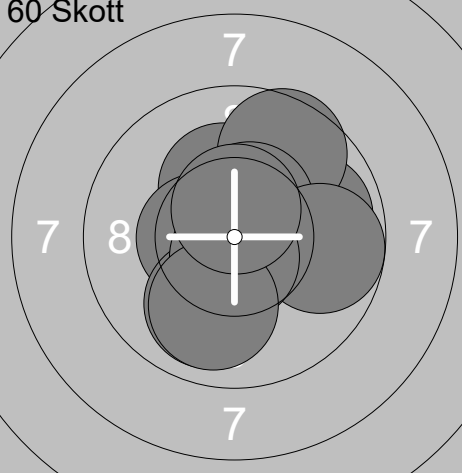
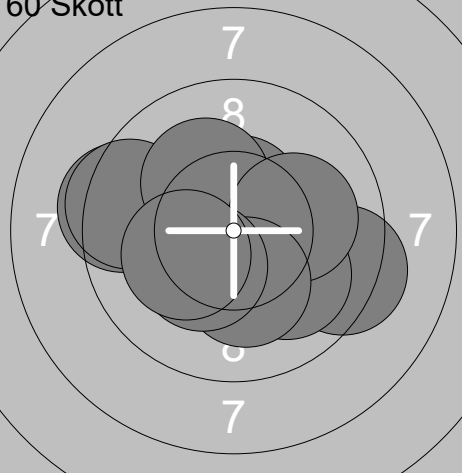
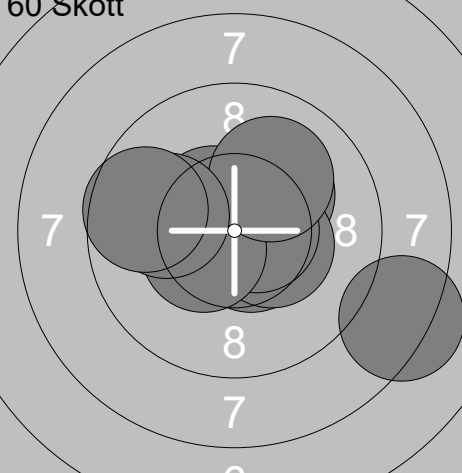
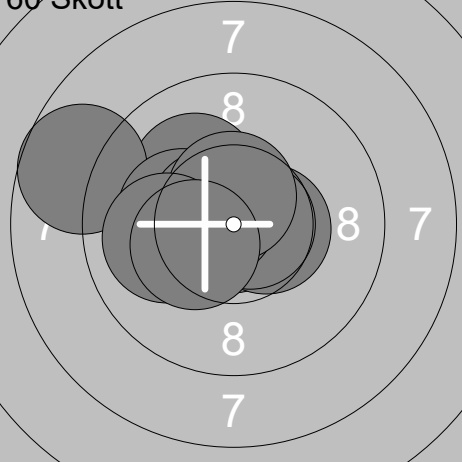
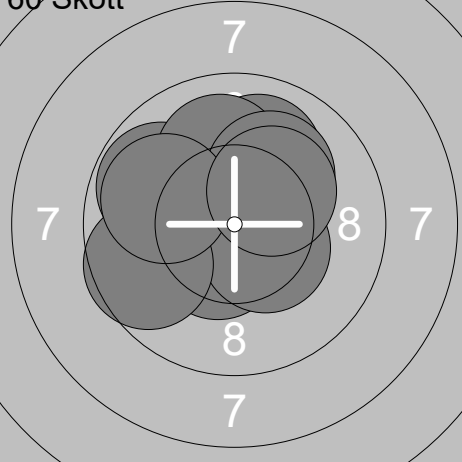
Skjuttag	Tavla	Nicolle Nygren			
2	12	Ramselefors	Umeå	15S	Vb
03.11.2019	Vindelnskyttet 2019	Ramselefors SKF			
<b>Prov</b> 	1: 10.4x ↘	<b>Prov</b> 	11: 10.8x ↗		
	2: 10.4x ↘		12: 9.8 ↑		
	3: 9.5 →		13: 9.3 ↗		
	4: 10.2x →		14: 10.0 →		
	5: 9.7 ↗		15: 9.3 ↗		
	6: 10.6x →		16: 10.9x ↗		
	7: 9.9 ←				
	8: 10.1 ↗				
	9: 10.7x ↗				
	10: 10.4x ↗				
	Serie 101.9		Serie 60.1		
	Total 0.0		Total 0.0		
<b>60 Skott</b> 	1: 10.3x ↗	<b>60 Skott</b> 	11: 9.9 →		
	2: 10.3x ↗		12: 10.3x ↗		
	3: 10.1 ↗		13: 9.6 ↗		
	4: 10.8x ↘		14: 10.5x ↗		
	5: 10.2x →		15: 9.8 →		
	6: 10.3x ↑		16: 10.5x ←		
	7: 10.2x ↗		17: 10.0 ↓		
	8: 10.3x ↗		18: 10.7x ↓		
	9: 10.6x ↘		19: 10.0 ↓		
	10: 10.0 ↘		20: 10.6x ↑		
	Serie 103.1		Serie 101.9		
	Total 103.1		Total 205.0		
<b>60 Skott</b> 	21: 10.5x ↑	<b>60 Skott</b> 	31: 10.2x ↗		
	22: 9.3 →		32: 10.6x ↘		
	23: 9.4 ←		33: 10.4x →		
	24: 9.5 ←		34: 10.6x →		
	25: 10.0 ↘		35: 10.5x ↗		
	26: 10.2x ↗		36: 10.4x ←		
	27: 10.1 →		37: 10.0 ↗		
	28: 10.2x ↘		38: 10.0 ←		
	29: 10.3x ↘		39: 8.3 →		
	30: 10.2x ↘		40: 9.6 ←		
	Serie 99.7		Serie 100.6		
	Total 304.7		Total 405.3		
<b>60 Skott</b> 	41: 10.1 ↗	<b>60 Skott</b> 	51: 10.0 ↗		
	42: 8.7 ↗		52: 9.8 ↗		
	43: 10.9x ↘		53: 10.8x ↘		
	44: 10.5x →		54: 10.5x ↘		
	45: 10.2x ←		55: 10.0 ↑		
	46: 10.7x →		56: 10.4x ↘		
	47: 10.6x ↗		57: 9.6 ←		
	48: 10.6x ↑		58: 10.1 ↗		
	49: 10.0 ←		59: 9.9 ←		
	50: 10.3x ↘		60: 10.3x ↗		
	Serie 102.6		Serie 101.4		
	Total 507.9		Total 609.3		

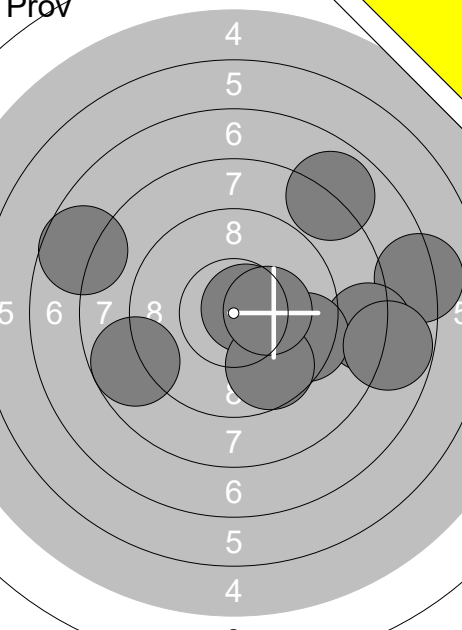
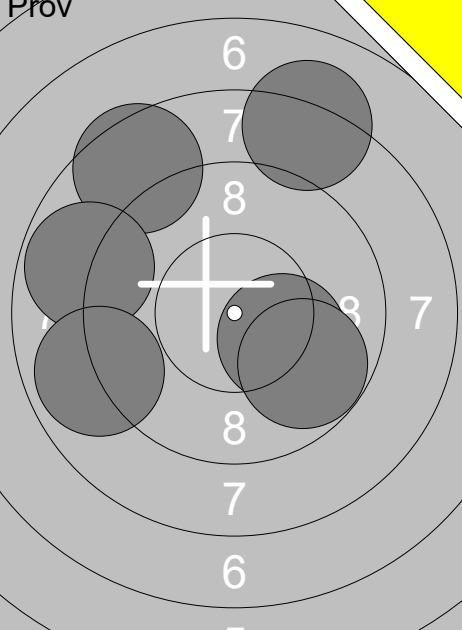
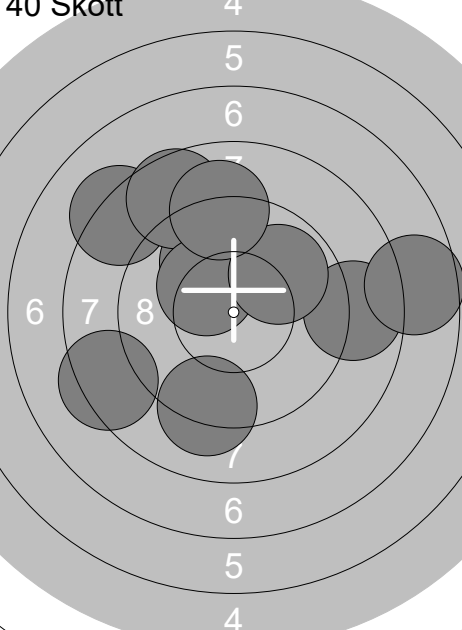
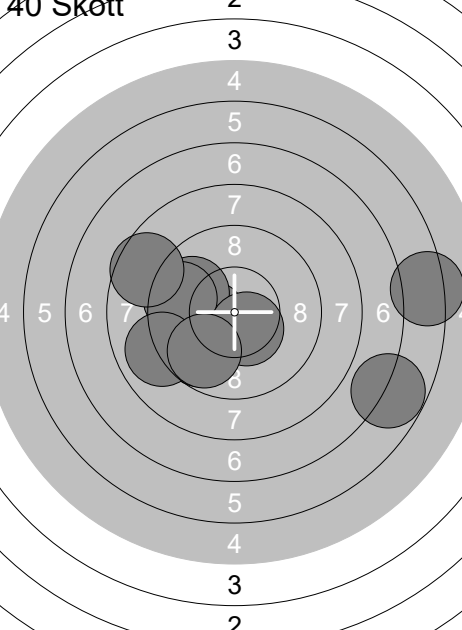
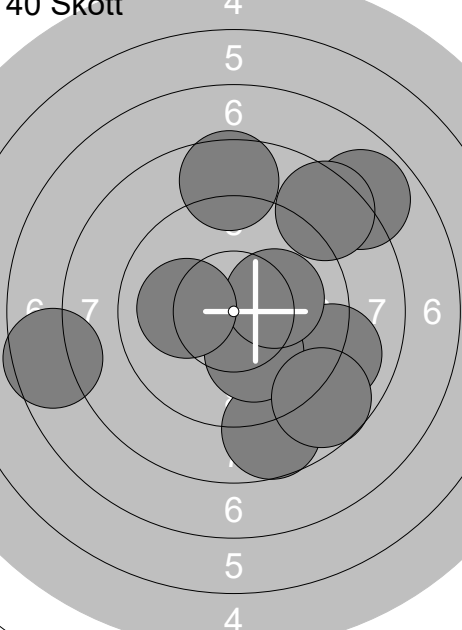
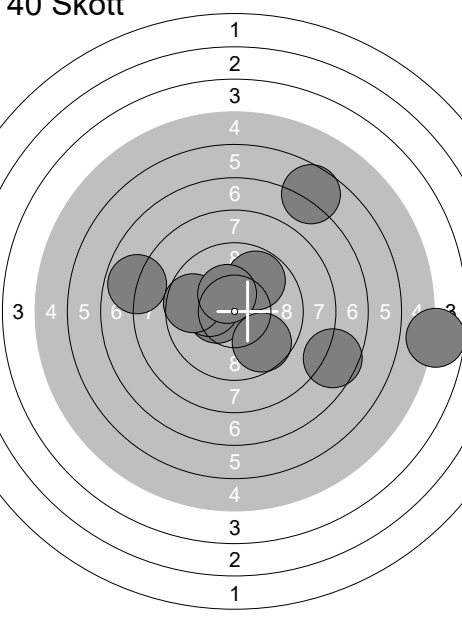
Skjuttlag <b>2</b>	Tavla <b>14</b>	<b>Vilda Stridsson</b>	
Ramselefors	Gällivare	13S	No
03.11.2019	Vindelnskyttet 2019	Ramselefors SKF	
Prov			
	1: 7.2 → 2: 10.7x → 3: 8.2 → 4: 7.9 ↗ 5: 7.7 ← 6: 9.4 → 7: 9.7 ↓ 8: 10.3x → 9: 8.8 ← 10: 7.8 → Serie 82 Total 0	11: 8.5 ↗ 12: 10.2x → 13: 8.8 ← 14: 8.2 ↗ 15: 9.8 ↓ 16: 8.9 ← Serie 51 Total 0	
40 Skott			
	1: 9.9 ↗ 2: 8.2 ↗ 3: 8.6 ↗ 4: 10.3x ↗ 5: 8.4 ← 6: 8.8 → 7: 7.6 → 8: 9.2 ↓ 9: 9.9 ↗ 10: 9.1 ↑ Serie 85 Total 85	11: 6.2 → 12: 9.7 ↓ 13: 10.3x ← 14: 9.8 ← 15: 9.6 ← 16: 8.6 ← 17: 9.0 ← 18: 10.5x ↓ 19: 6.8 → 20: 9.8 ↓ Serie 85 Total 170	
40 Skott			
	21: 9.0 → 22: 8.7 ↓ 23: 10.1 ↓ 24: 7.9 ↗ 25: 8.6 ↑ 26: 8.5 ↗ 27: 10.2x → 28: 7.6 ← 29: 10.1 ← 30: 8.7 ↓ Serie 85 Total 255	31: 4.8 → 32: 9.8 ↗ 33: 10.4x ← 34: 7.6 → 35: 9.7 ↓ 36: 7.9 ← 37: 6.7 ↗ 38: 10.2x ← 39: 9.6 ← 40: 10.4x ↗ Serie 81 Total 336	



Skjuttag	Tavla	Einar Kurkkio	
2	16	Ramselefors	Gällivare
03.11.2019		Vindelnskyttet 2019	Ramselefors SKF
15S	No		
<b>Pröv</b> 	1: 9.4 ↗ 2: 6.8 ↗ 3: 5.0 → 4: 9.2 ← 5: 8.8 ↑ 6: 8.6 → 7: 8.4 → 8: 5.8 ↑ 9: 9.4 → 10: 9.5 ↑ Serie 76 Total 0	<b>Pröv</b> 	11: 10.2x ↖ 12: 8.8 → 13: 9.3 ↗ 14: 8.5 → 15: 7.1 → 16: 5.0 ↗ 17: 8.9 ↖ 18: 8.1 ↗ 19: 8.8 ↑ 20: 6.1 → Serie 77 Total 0
<b>Pröv</b> 	21: 10.3x ↘ 22: 10.0 ↘ 23: 5.8 ↗ 24: 7.7 ↗ 25: 7.4 ↗ 26: 7.1 → 27: 10.0 ← 28: 5.4 ↗ 29: 8.8 → Serie 69 Total 0	<b>40 Skott</b> 	1: 9.0 ↗ 2: 9.5 ↗ 3: 7.1 ↗ 4: 7.8 → 5: 8.4 → 6: 8.4 ↗ 7: 6.6 ← 8: 10.1 ↑ 9: 9.7 ← 10: 7.6 → Serie 80 Total 80
<b>40 Skott</b> 	11: 5.9 ↗ 12: 10.0 → 13: 9.3 ↑ 14: 9.7 → 15: 6.4 ← 16: 8.3 → 17: 7.7 ↑ 18: 9.5 ← 19: 7.1 ↑ 20: 6.4 → Serie 76 Total 156	<b>40 Skott</b> 	21: 9.4 ↘ 22: 9.3 ↗ 23: 8.1 → 24: 7.9 ↗ 25: 9.6 ↗ 26: 10.0 → 27: 7.6 → 28: 8.8 ↖ 29: 9.5 ↑ 30: 8.7 ↗ Serie 84 Total 240
<b>40 Skott</b> 	31: 9.3 ← 32: 10.7x ↑ 33: 8.9 ↗ 34: 6.0 → 35: 9.2 ↓ 36: 9.0 ↘ 37: 9.9 ↗ 38: 6.8 → 39: 8.1 ↗ 40: 9.0 ↘ Serie 83 Total 323		

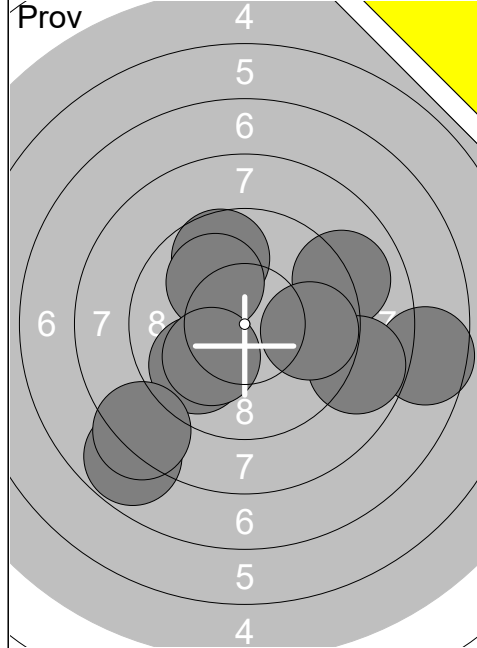

1:	9.7	↗
2:	9.0	→
3:	7.8	↘
4:	7.6	→
5:	8.8	→
6:	9.8	↙
7:	8.3	↘
8:	10.0	↗
9:	10.1	↘
10:	9.8	→
Serie	90.9	
Total	0.0	

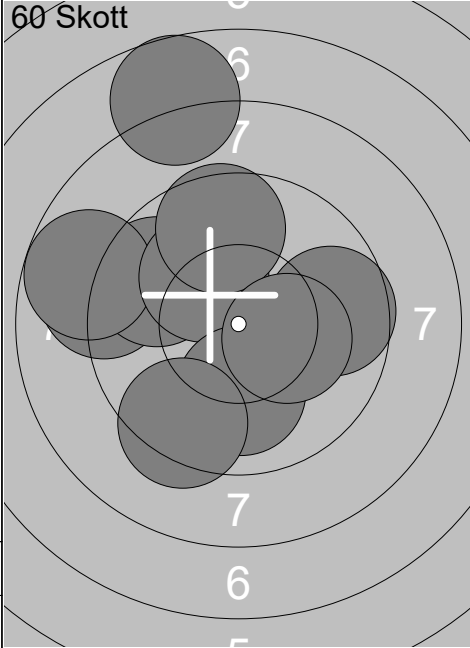

1:	9.7	→
2:	9.0	←
3:	9.7	↖
4:	8.8	←
5:	10.1	↗
6:	9.6	↑
7:	10.0	↓
8:	7.7	↑
9:	10.3x	→
10:	9.4	↘
Serie	94.3	
Total	94.3	

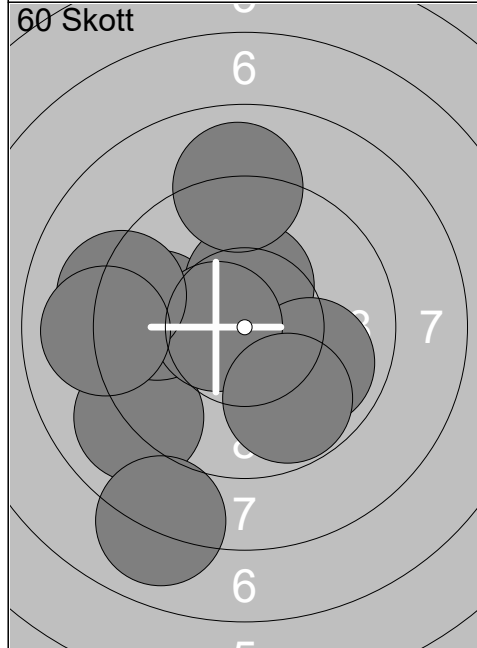

11:	9.0	↘
12:	9.7	←
13:	10.4x	↑
14:	9.9	→
15:	10.6x	←
16:	9.8	↘
17:	9.2	←
18:	9.0	←
19:	9.0	↑
20:	8.0	↘
Serie	94.6	
Total	188.9	

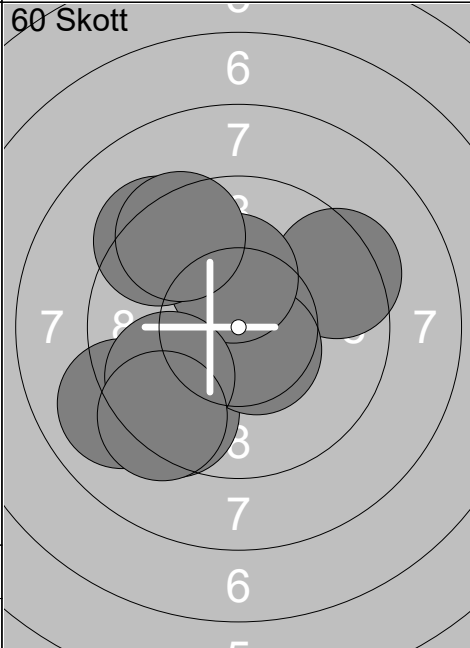

21:	9.0	↖
22:	10.9x	→
23:	9.5	↘
24:	9.4	→
25:	10.5x	↘
26:	10.3x	↑
27:	9.8	↖
28:	9.3	↗
29:	9.3	↘
30:	9.5	↗
Serie	97.5	
Total	286.4	

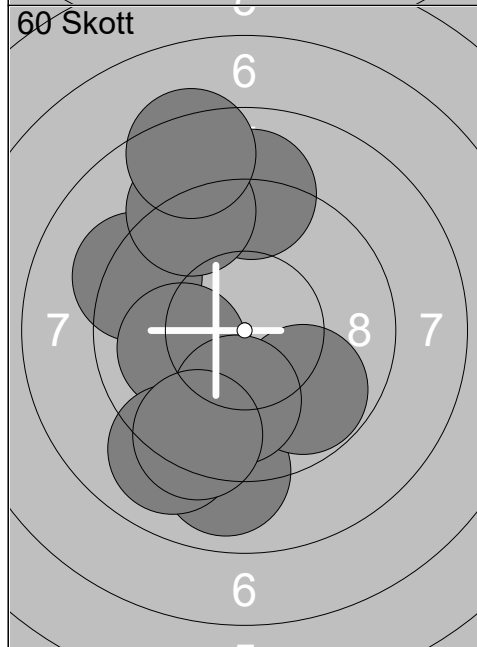

31:	9.3	↖
32:	9.1	↑
33:	9.1	↗
34:	9.0	↓
35:	10.0	←
36:	9.8	↘
37:	10.0	↓
38:	9.0	↘
39:	8.4	↑
40:	9.4	↘
Serie	93.1	
Total	379.5	

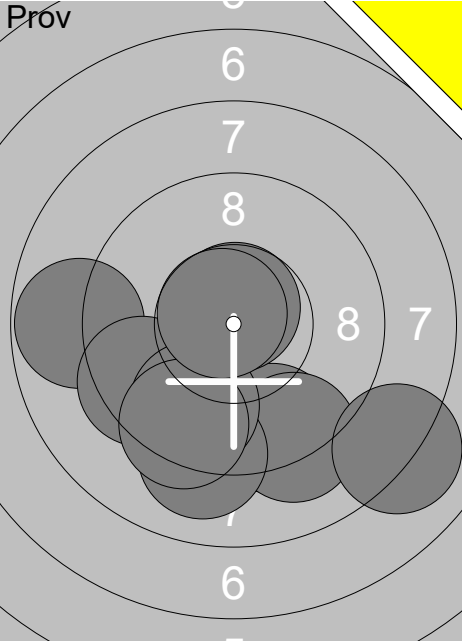
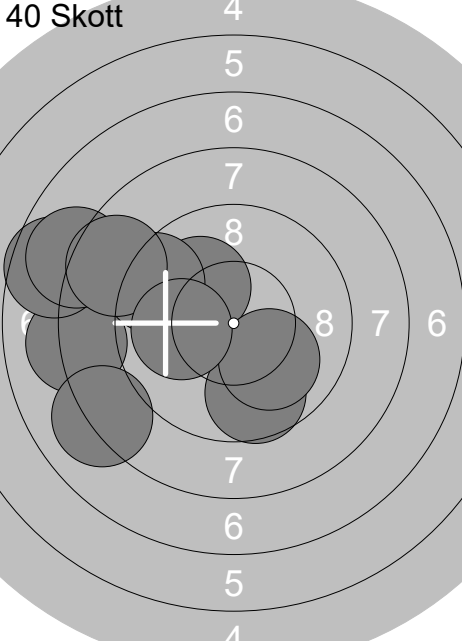
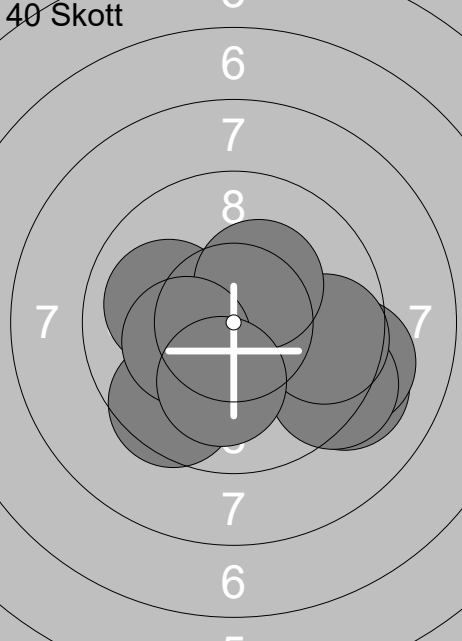
Skjuttag	Tavla	Nadja Kurkkio	
2	18	Ramselefors	Gällivare
03.11.2019		Vindelnskyttet 2019	Ramselefors SKF
15S		No	
Prov		1: 9.4 ↓ 2: 8.8 ← 3: 9.2 ↓ 4: 8.1 ↓ 5: 9.4 ← 6: 9.1 ↓ 7: 10.7x ↑ 8: 9.7 ↓ 9: 9.4 ↓ 10: 10.7x ↖ Serie 90 Total 0	11: 10.0 ↗ 12: 10.4x ← 13: 10.3x ↖ Serie 30 Total 0
40 Skott		1: 8.1 ← 2: 8.1 ← 3: 7.6 ← 4: 9.7 ↓ 5: 10.1 ↗ 6: 10.1 ↓ 7: 7.9 ↖ 8: 9.4 ↖ 9: 8.6 ↖ 10: 10.0 ← Serie 86 Total 86	11: 8.6 → 12: 7.7 → 13: 9.5 ↗ 14: 9.5 ↓ 15: 9.6 ↖ 16: 10.0 ← 17: 9.0 ← 18: 9.2 → 19: 7.5 → 20: 9.7 ↖ Serie 86 Total 172
40 Skott		21: 9.6 ↓ 22: 10.0 ← 23: 10.5x ← 24: 9.2 ↓ 25: 9.2 → 26: 9.3 ↓ 27: 9.7 → 28: 10.3x ↗ 29: 10.3x ← 30: 10.1 ↓ Serie 95 Total 267	31: 10.7x ↑ 32: 10.6x → 33: 9.5 ↗ 34: 9.0 → 35: 10.4x ↖ 36: 10.5x ↑ 37: 9.3 → 38: 7.8 ↖ 39: 10.1 → 40: 9.2 ← Serie 93 Total 360

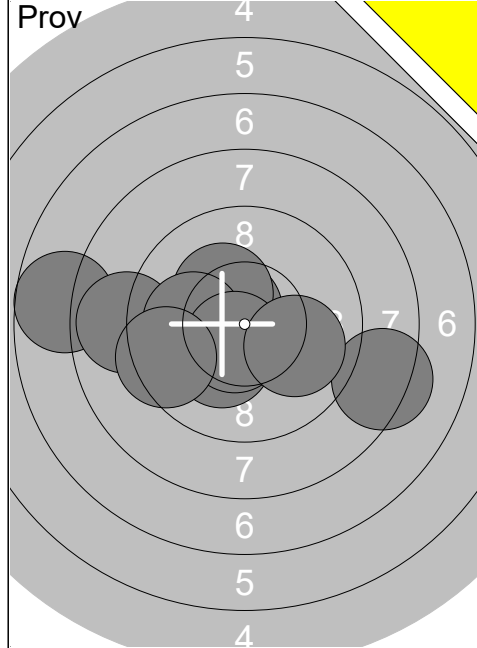

1:	7.7	←
2:	8.3	→
3:	10.2x	↙
4:	10.6x	↗
5:	10.3x	↗
6:	8.8	←
7:	10.0	←
8:	10.6x	↙
9:	10.0	→
10:	9.4	←
<b>Serie</b>	<b>92</b>	
<b>Total</b>	<b>0</b>	

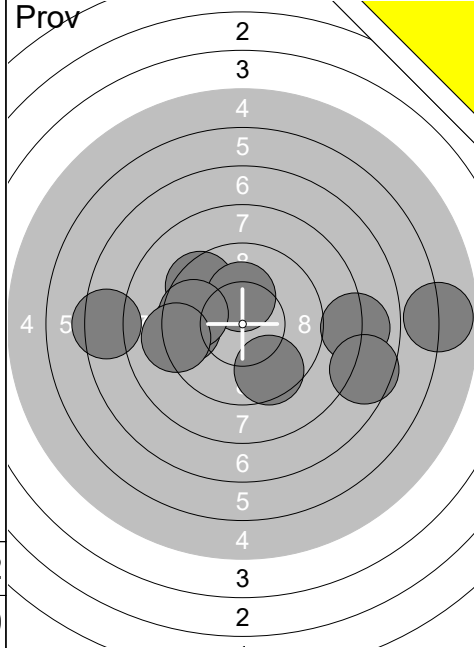

11:	5.9	→
12:	8.0	→
13:	9.5	↗
14:	9.6	↘
15:	7.4	←
16:	9.5	←
17:	7.6	→
18:	10.2x	↑
19:	9.7	←
20:	9.2	←
<b>Serie</b>	<b>82</b>	
<b>Total</b>	<b>0</b>	

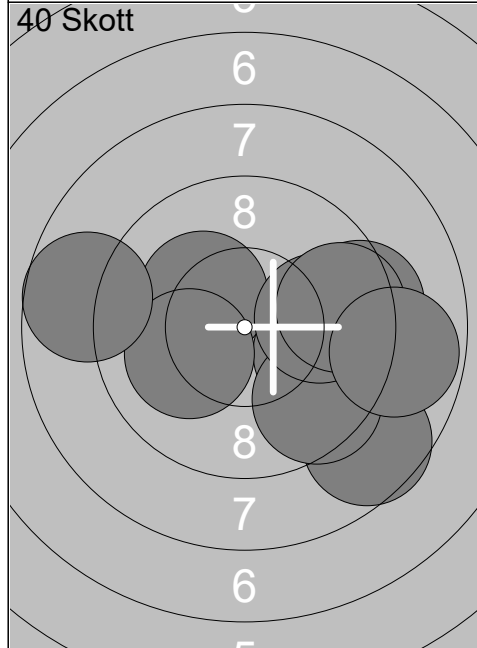

1:	8.6	↘
2:	9.3	→
3:	9.9	→
4:	9.5	↘
5:	10.2x	↗
6:	10.1	←
7:	8.7	←
8:	9.9	→
9:	9.6	→
10:	8.8	→
<b>Serie</b>	<b>89</b>	
<b>Total</b>	<b>89</b>	

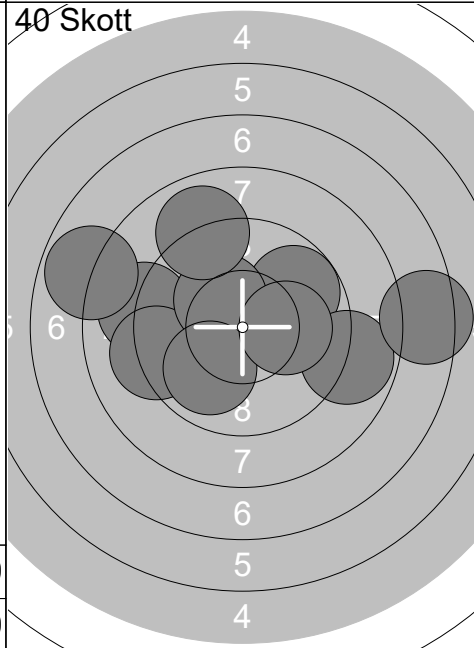

11:	9.0	←
12:	9.8	↗
13:	9.2	←
14:	10.3x	↗
15:	9.9	↘
16:	8.8	→
17:	10.1	→
18:	7.4	→
19:	7.9	←
20:	9.0	↑
<b>Serie</b>	<b>87</b>	
<b>Total</b>	<b>176</b>	

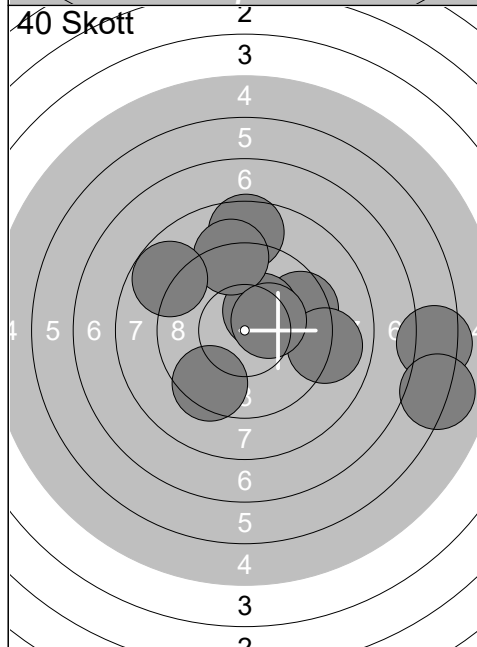

21:	9.5	→
22:	6.4	→
23:	10.3x	↗
24:	9.0	→
25:	8.6	↑
26:	9.2	↑
27:	10.3x	→
28:	9.4	↘
29:	8.8	↖
30:	6.1	→
<b>Serie</b>	<b>84</b>	
<b>Total</b>	<b>260</b>	

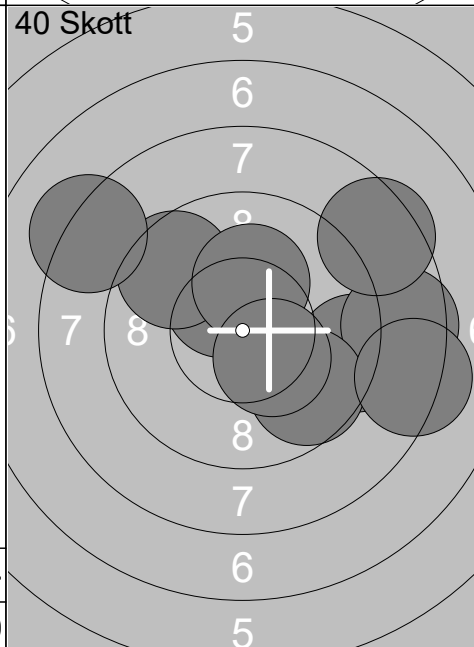

31:	9.2	→
32:	8.6	→
33:	10.4x	↗
34:	9.6	↖
35:	8.5	↗
36:	10.2x	↑
37:	8.2	↖
38:	9.7	↘
39:	10.3x	↘
40:	8.3	→
<b>Serie</b>	<b>89</b>	
<b>Total</b>	<b>349</b>	

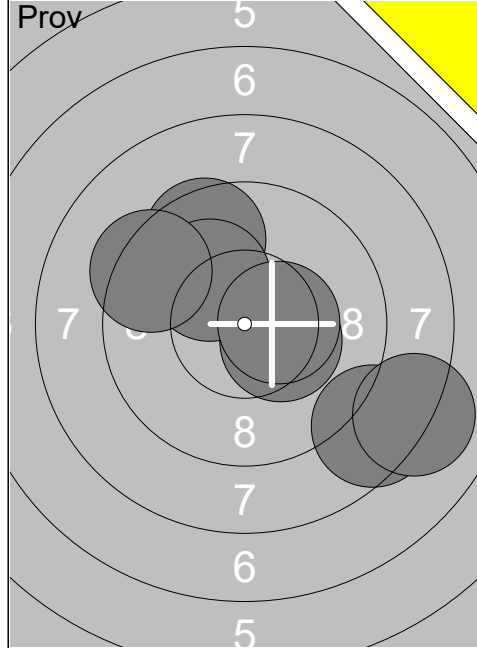

1:	10.4x	↘
2:	8.5	↘
3:	9.6	↗
4:	10.1	↗
5:	10.4x	→
6:	8.1	↘
7:	9.4	↖
<b>Serie</b>		<b>64</b>
<b>Total</b>		<b>0</b>

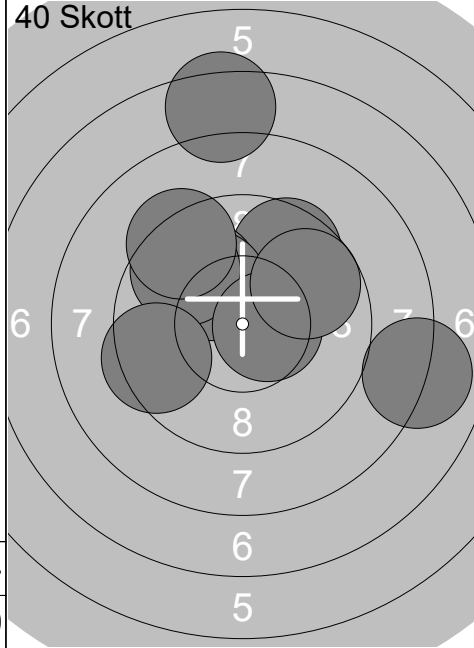

1:	9.6	↗
2:	8.0	→
3:	10.0	↖
4:	7.4	↑
5:	10.2x	↖
6:	9.7	↖
7:	10.5x	→
8:	9.7	↗
9:	9.3	↖
10:	9.4	←
<b>Serie</b>		<b>90</b>
<b>Total</b>		<b>90</b>

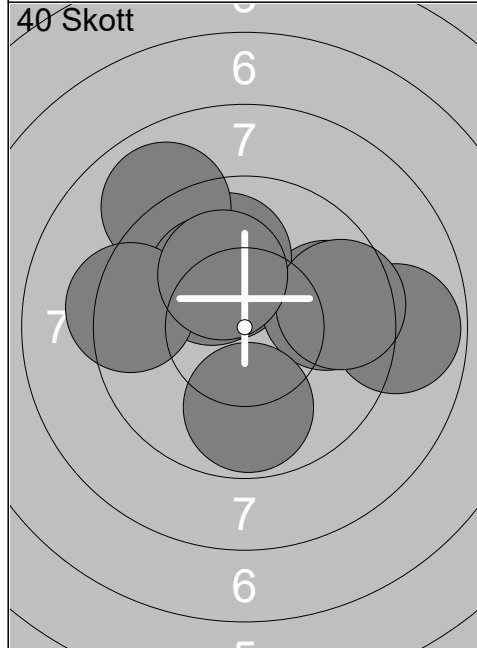

11:	8.8	→
12:	10.2x	↗
13:	9.8	→
14:	10.0	↑
15:	9.0	↗
16:	9.6	→
17:	10.2x	↖
18:	9.3	←
19:	9.8	↓
20:	10.2x	↖
<b>Serie</b>		<b>93</b>
<b>Total</b>		<b>183</b>

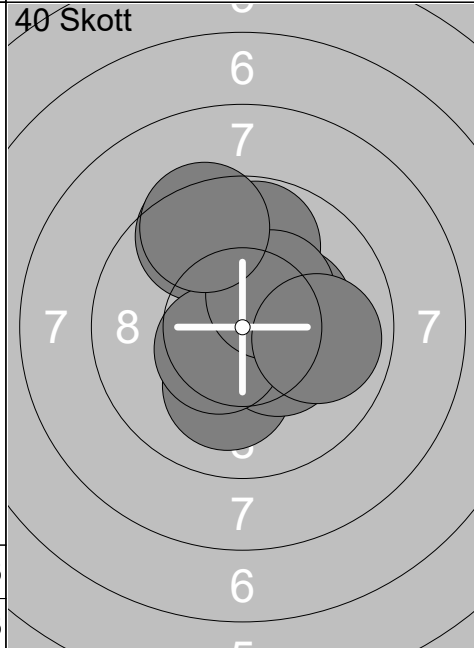

21:	9.6	↖
22:	10.3x	→
23:	10.1	↓
24:	9.8	↑
25:	10.3x	→
26:	10.3x	↘
27:	10.5x	↙
28:	10.4x	↗
29:	9.5	↑
30:	9.9	→
<b>Serie</b>		<b>96</b>
<b>Total</b>		<b>279</b>

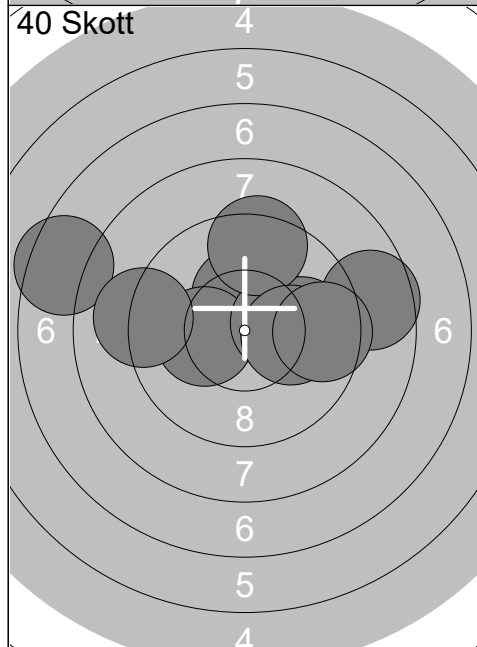

31:	7.5	←
32:	10.3x	↑
33:	10.2x	←
34:	10.3x	→
35:	8.6	→
36:	9.1	←
37:	9.9	→
38:	9.4	↑
39:	10.1	→
40:	9.5	→
<b>Serie</b>		<b>91</b>
<b>Total</b>		<b>370</b>

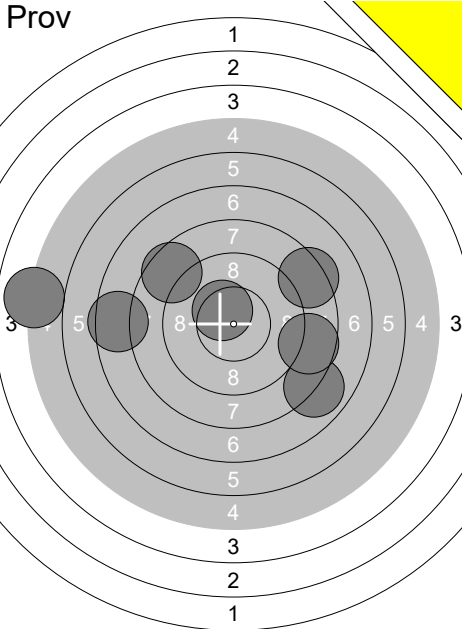
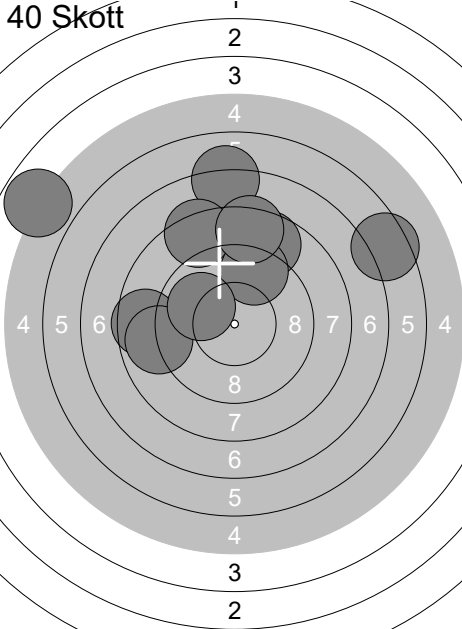
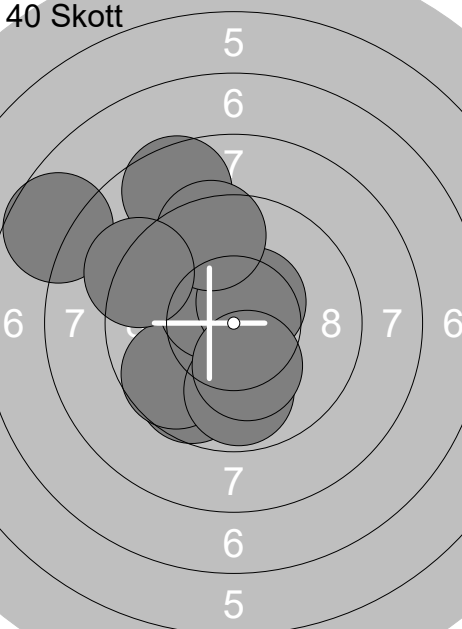
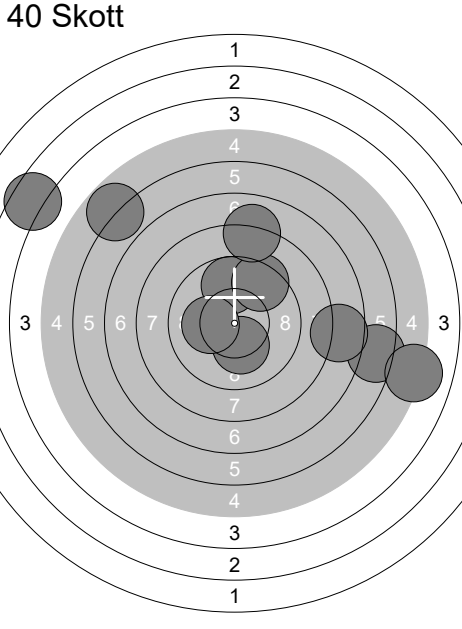
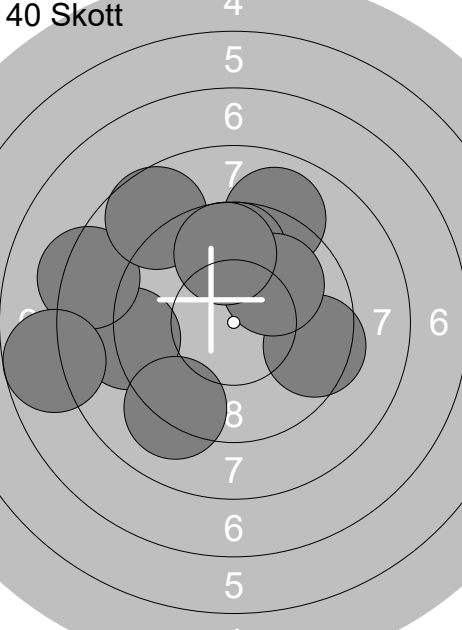
Skjutlag <b>2</b>	Tavla <b>21</b>	<b>Sofia Öhman</b>	
Ramselefors	Gällivare	13S	No
03.11.2019	Vindelnskyttet 2019	Ramselefors SKF	
Prov		40 Skott	
	1: 8.3 ↗ 2: 10.4x ↖ 3: 7.5 ← 4: 5.0 ← 5: 7.9 ↘ 6: 8.6 → 7: 8.6 ↗		1: 8.6 ← 2: 7.1 ↑ 3: 4.8 ↖ 4: 8.9 ← 5: 6.5 ↗ 6: 8.7 ↗ 7: 8.4 ↗ 8: 9.5 ↗ 9: 8.4 ↑ 10: 10.0 ↖
	Serie 53		Serie 76
	Total 0		Total 76
40 Skott		40 Skott	
	11: 9.7 ↘ 12: 8.6 ↑ 13: 9.7 ↘ 14: 10.5x ↖ 15: 7.7 ← 16: 10.5x ↗ 17: 9.5 ↑ 18: 9.8 ↓ 19: 10.2x ↓ 20: 9.2 ↖		21: 6.4 → 22: 10.2x ↓ 23: 7.7 → 24: 3.5 ↖ 25: 9.8 ↑ 26: 5.1 → 27: 9.4 ↗ 28: 8.1 ↑ 29: 5.8 ↖ 30: 10.2x ←
	Serie 90		Serie 72
	Total 166		Total 238
40 Skott			
	31: 9.5 → 32: 9.1 ← 33: 9.0 ↑ 34: 8.3 ← 35: 9.1 ↘ 36: 7.7 ← 37: 9.7 ↑ 38: 8.7 ↖ 39: 10.0 ↗ 40: 9.7 ↑		
	Serie 87		
	Total 325		

Skjuttag	Tavla	Emma Eriksson	
2	22	Ramselefors	Vb
03.11.2019	Vindelnskyttet 2019	Ramselefors SKF	17S
Prov		Prov	
	1: 10.4x ↘ 2: 9.9 → 3: 9.6 → 4: 9.7 ↗ 5: 8.9 ↑ 6: 9.9 → 7: 9.6 ↗ 8: 7.3 → 9: 8.4 ↓ 10: 9.4 ↓		11: 8.5 ← 12: 10.0 ↓ 13: 9.1 ↓ 14: 9.5 ↗ 15: 10.4x ↓ 16: 9.4 ← 17: 6.9 ← 18: 8.5 →
Serie 87	Total 0	Serie 69	Total 0
40 Skott		40 Skott	
	1: 9.7 ↗ 2: 10.2x ↗ 3: 9.0 ↗ 4: 9.5 → 5: 9.5 ← 6: 9.6 → 7: 9.1 ↓ 8: 6.2 ← 9: 9.7 ↑ 10: 10.4x →		11: 7.9 ↖ 12: 8.4 ← 13: 9.9 → 14: 10.0 ← 15: 10.9x → 16: 9.5 ↖ 17: 10.3x ↓ 18: 10.1 ↑ 19: 8.8 ← 20: 10.7x ↙
Serie 89	Total 89	Serie 91	Total 180
40 Skott		40 Skott	
	21: 9.0 ← 22: 10.5x ↑ 23: 7.4 ↓ 24: 10.3x → 25: 9.8 ↗ 26: 6.7 ← 27: 9.7 → 28: 9.6 ← 29: 9.9 ↗ 30: 10.1 ↖		31: 9.3 → 32: 10.1 ← 33: 10.4x ↓ 34: 9.4 → 35: 10.8x → 36: 10.0 ↓ 37: 9.5 ↗ 38: 9.2 ↓ 39: 10.5x → 40: 10.9x →
Serie 88	Total 268	Serie 96	Total 364

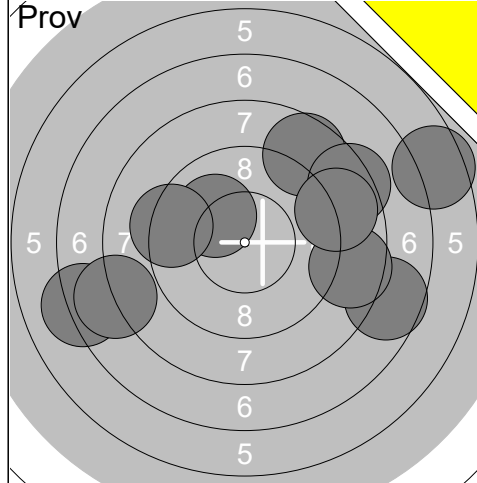

1:	7.6	➔
2:	8.6	↗
3:	6.5	➔
4:	10.1	↗
5:	8.6	➔
6:	7.2	↖
7:	8.4	➔
8:	7.9	↖
9:	8.8	➔
10:	9.3	↖
Serie		78
Total		0

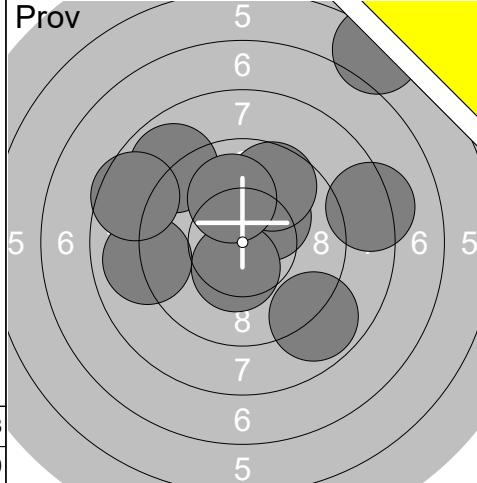

11:	10.2x	↗
12:	10.4x	↘
13:	9.0	↖
14:	9.7	↗
15:	8.3	➔
16:	8.9	↗
17:	6.2	↗
18:	8.9	↘
19:	8.6	↖
20:	10.0	↗
Serie		86
Total		0

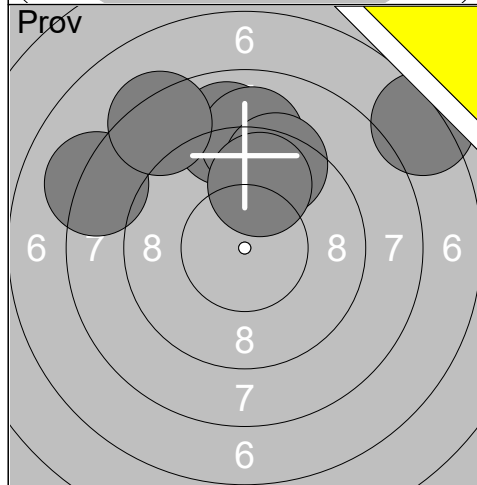

21:	8.9	↗
22:	9.1	↗
23:	8.1	↖
24:	9.4	↗
25:	7.2	➔
26:	9.8	↗
27:	8.3	↗
Serie		58
Total		0

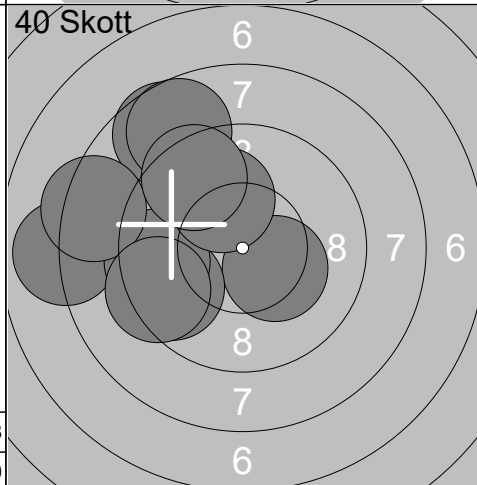

1:	10.3x	➔
2:	8.0	↖
3:	9.6	↖
4:	8.6	↗
5:	9.5	↖
6:	8.3	↖
7:	8.7	↗
8:	10.1	↗
9:	9.5	↗
10:	9.4	↖
Serie		88
Total		88

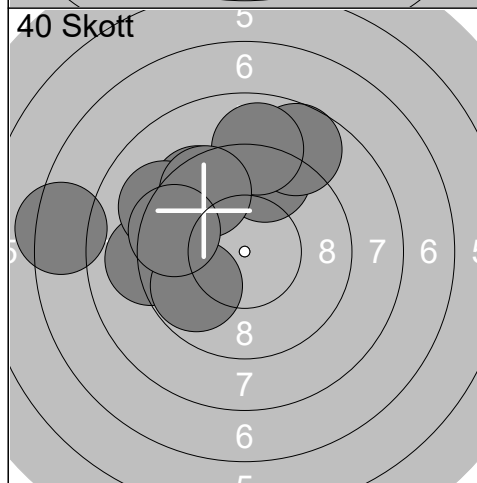

11:	9.5	↖
12:	7.3	↖
13:	9.1	↖
14:	9.4	↗
15:	8.7	↗
16:	9.2	↖
17:	8.9	↗
18:	9.6	↗
19:	9.8	↖
20:	9.5	↖
Serie		86
Total		174

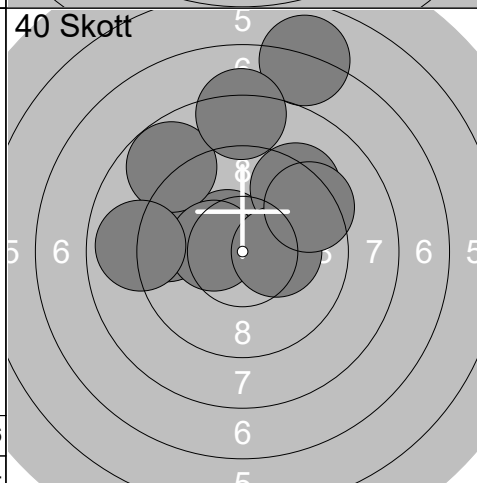

21:	7.0	↗
22:	10.5x	↗
23:	9.4	↖
24:	8.8	↗
25:	10.4x	↖
26:	9.3	↗
27:	8.2	↗
28:	10.3x	➔
29:	8.9	↖
30:	9.4	↗
Serie		88
Total		262

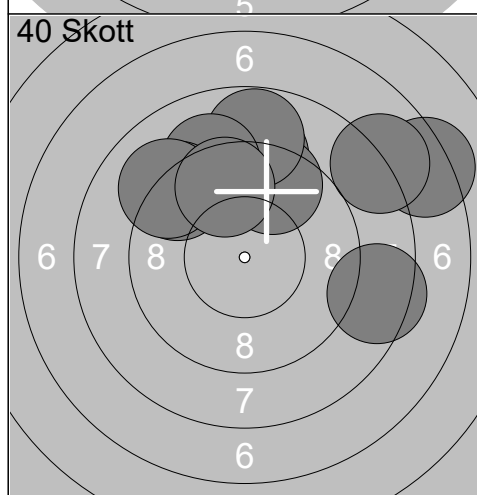

31:	9.1	↗
32:	7.3	➔
33:	8.0	➔
34:	9.5	↗
35:	8.8	↗
36:	9.1	↗
37:	9.2	↗
38:	9.1	↗
39:	8.5	➔
40:	9.6	↗
Serie		85
Total		347

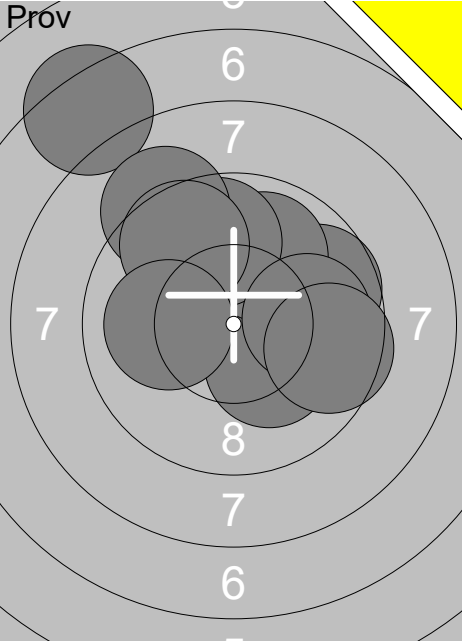
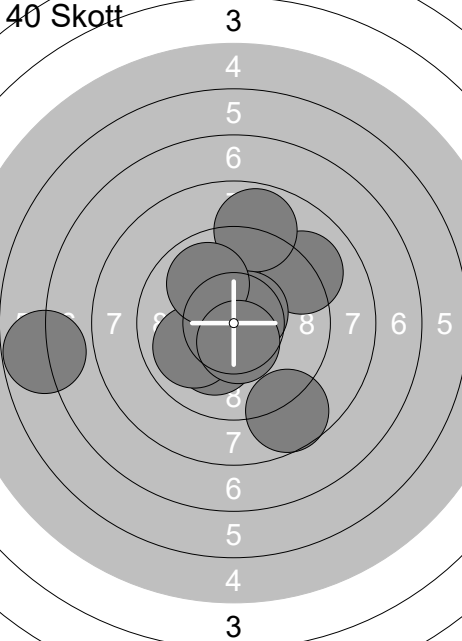
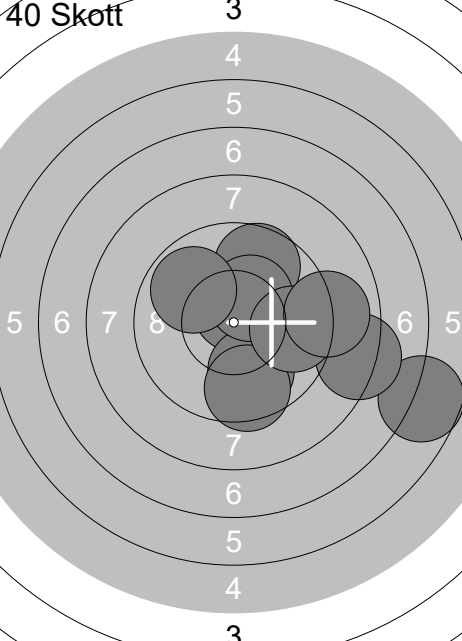

Skjutlag	Tavla	Karin Johansson		Vet	Vb
2	24	Ramselefors	Vännäs		
03.11.2019	Vindelnskyttet 2019	Ramselefors SKF			
Prov		1: 7.4 ↗	11: 9.3 ↖		
		2: 10.2x ↘	12: 9.3 ↓		
		3: 9.7 →	13: 10.3x ↘		
		4: 9.9 ↑	14: 9.1 ←		
		5: 9.8 ↑	15: 9.0 ←		
		6: 9.1 ↗	16: 8.7 ↗		
		7: 9.9 →	17: 9.8 ←		
		8: 9.6 →			
		9: 9.7 ↗			
		10: 10.0 ←			
		Serie 90	Serie 63		
		Total 0	Total 0		
40 Skott		1: 10.2x ↘	11: 8.1 →		
		2: 10.0 ←	12: 9.6 ↑		
		3: 10.1 ↑	13: 10.0 ↘		
		4: 9.1 ↗	14: 9.7 ↗		
		5: 8.9 ↑	15: 9.8 ↘		
		6: 8.7 ↘	16: 9.2 ↗		
		7: 10.6x ↗	17: 10.3x ↘		
		8: 9.9 ↑	18: 9.0 ↗		
		9: 10.5x ↘	19: 10.7x ↘		
		10: 6.8 ←	20: 9.8 →		
		Serie 90	Serie 92		
		Total 90	Total 182		
40 Skott		21: 6.7 →	31: 10.7x →		
		22: 10.7x ↑	32: 10.4x →		
		23: 9.7 ↑	33: 10.0 ↘		
		24: 9.9 ↘	34: 8.3 ←		
		25: 10.3x ↗	35: 8.4 →		
		26: 9.9 ↖	36: 9.4 ↗		
		27: 8.2 →	37: 10.6x ↗		
		28: 9.5 ↘	38: 9.7 ↘		
		29: 9.7 →	39: 8.3 →		
		30: 9.0 →	40: 10.3x →		
		Serie 88	Serie 92		
		Total 270	Total 362		

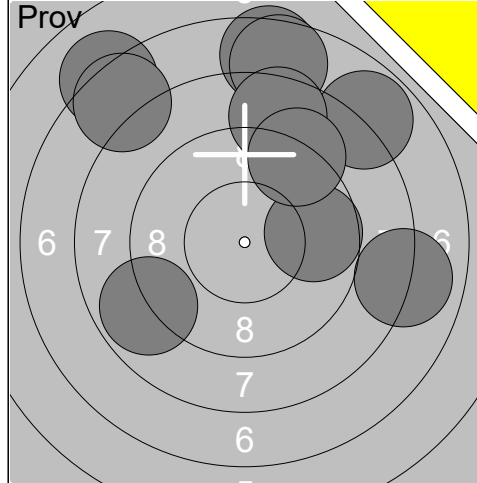

11:	9.2	↗
12:	8.2	↑
13:	8.2	←
14:	8.2	↗
15:	10.1	→
16:	9.2	↗
17:	9.6	↗
18:	8.7	↓
19:	9.4	↗
20:	8.5	↗
<b>Serie</b>		<b>86</b>
<b>Total</b>		<b>0</b>

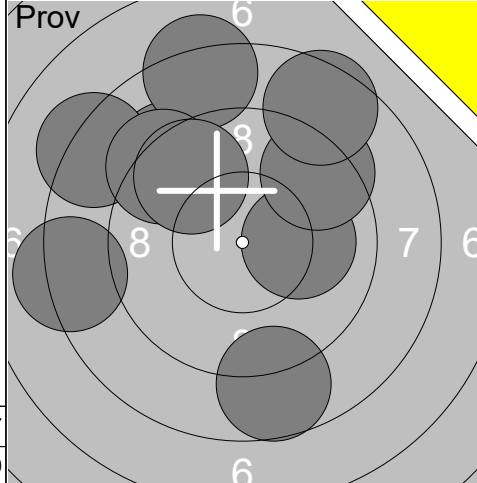

1:	9.0	→
2:	9.8	↗
3:	9.6	↑
4:	7.9	↗
5:	10.2x	↑
6:	7.5	↖
7:	7.5	→
8:	8.2	↑
9:	9.8	↑
10:	8.8	↖
<b>Serie</b>		<b>83</b>
<b>Total</b>		<b>83</b>

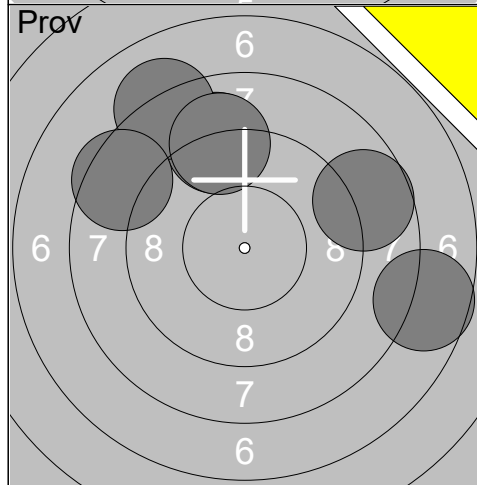

21:	9.8	↘
22:	7.6	→
23:	7.1	↑
24:	8.9	→
25:	8.7	↗
26:	9.2	↗
27:	9.4	↑
28:	9.2	↖
29:	9.8	↖
30:	10.0	↗
<b>Serie</b>		<b>85</b>
<b>Total</b>		<b>246</b>

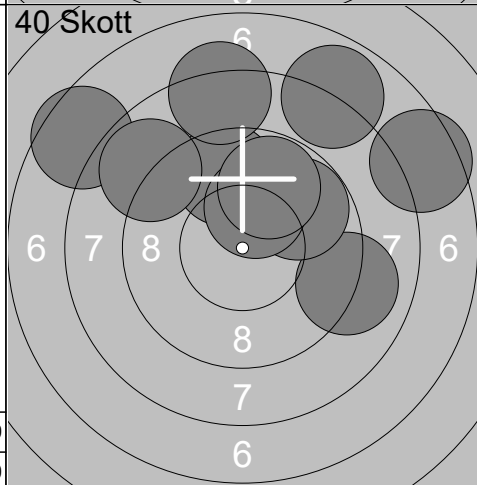

31:	7.4	→
32:	9.7	↑
33:	9.0	↗
34:	9.4	↖
35:	8.4	→
36:	6.9	↖
37:	9.5	↗
38:	10.4x	↖
39:	9.7	→
40:	10.6x	←
<b>Serie</b>		<b>86</b>
<b>Total</b>		<b>332</b>

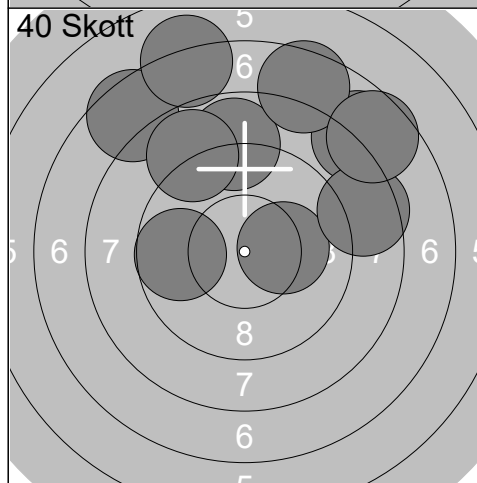

31:	7.4	→
32:	9.7	↑
33:	9.0	↗
34:	9.4	↖
35:	8.4	→
36:	6.9	↖
37:	9.5	↗
38:	10.4x	↖
39:	9.7	→
40:	10.6x	←
<b>Serie</b>		<b>86</b>
<b>Total</b>		<b>332</b>

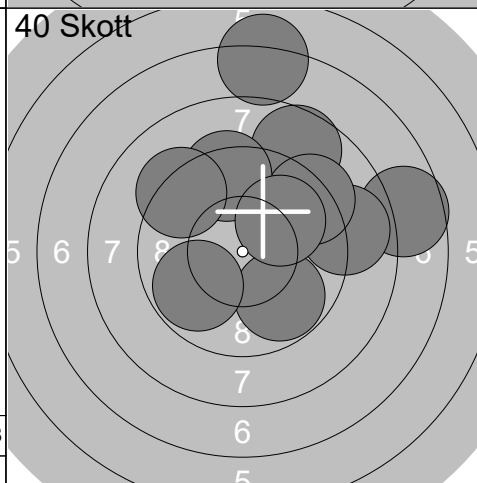

31:	7.4	→
32:	9.7	↑
33:	9.0	↗
34:	9.4	↖
35:	8.4	→
36:	6.9	↖
37:	9.5	↗
38:	10.4x	↖
39:	9.7	→
40:	10.6x	←
<b>Serie</b>		<b>86</b>
<b>Total</b>		<b>332</b>

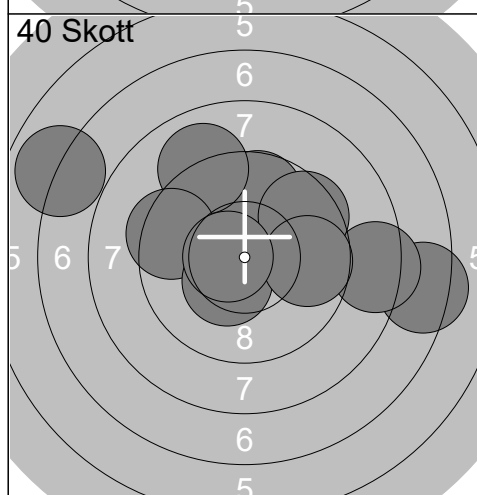

31:	7.4	→
32:	9.7	↑
33:	9.0	↗
34:	9.4	↖
35:	8.4	→
36:	6.9	↖
37:	9.5	↗
38:	10.4x	↖
39:	9.7	→
40:	10.6x	←
<b>Serie</b>		<b>86</b>
<b>Total</b>		<b>332</b>

31:	7.4	→
32:	9.7	↑
33:	9.0	↗
34:	9.4	↖
35:	8.4	→
36:	6.9	↖
37:	9.5	↗
38:	10.4x	↖
39:	9.7	→
40:	10.6x	←
<b>Serie</b>		<b>86</b>
<b>Total</b>		<b>332</b>

<p>Prov</p>	<p>1: 10.8x ←</p> <p>2: 3.9 ←</p> <p>3: 4.0 →</p> <p>4: 9.7 ↑</p> <p>5: 8.3 ↑</p> <p>6: 9.4 →</p> <p>7: 7.4 ←</p> <p>8: 9.0 ↑</p> <p>9: 5.3 ←</p> <p>10: 6.4 ↓</p>	<p>Prov</p>
Serie 70		Serie 15
Total 0		Total 0

<p>40 Skott</p>	<p>1: 10.8x →</p> <p>2: 7.9 ←</p> <p>3: 10.0 ↓</p> <p>4: 9.5 →</p> <p>5: 10.0 ←</p> <p>6: 9.4 ←</p> <p>7: 9.2 ←</p> <p>8: 8.3 →</p> <p>9: 8.1 ←</p> <p>10: 9.2 ↑</p>	<p>40 Skott</p>
Serie 89		Serie 81
Total 89		Total 170

<p>40 Skott</p>	<p>21: 10.3x ←</p> <p>22: 7.9 ↓</p> <p>23: 9.7 ↑</p> <p>24: 8.0 ↗</p> <p>25: 8.2 ↓</p> <p>26: 8.5 ↗</p> <p>27: 10.4x ↓</p> <p>28: 10.5x →</p> <p>29: 8.4 →</p> <p>30: 10.6x ↑</p>	<p>40 Skott</p>
Serie 88		Serie 89
Total 258		Total 347

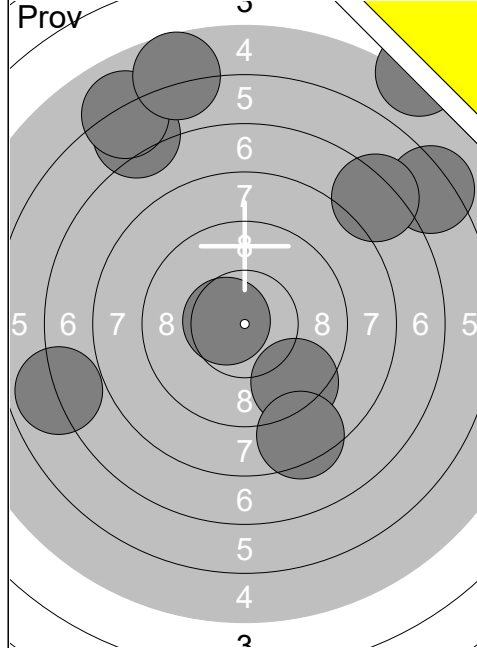

1:	4.7	↗
2:	10.6x	←
3:	6.9	←
4:	6.5	↗
5:	6.3	↗
6:	6.0	↗
7:	7.2	↗
8:	9.4	↘
9:	5.7	↗
10:	8.4	↘
<b>Serie</b>	<b>67</b>	
<b>Total</b>	<b>0</b>	

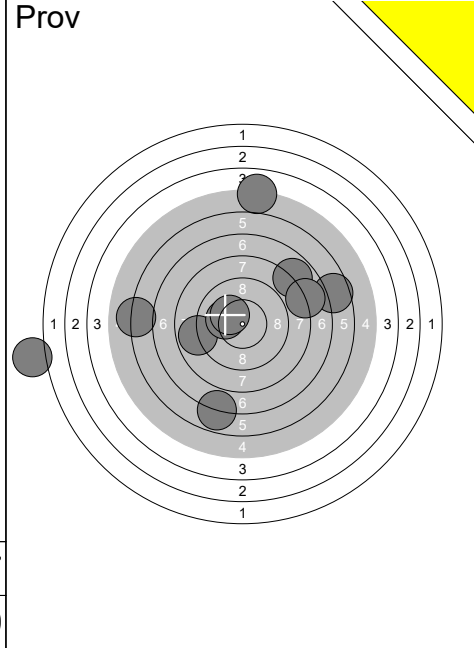

11:	8.9	←
12:	10.1	←
13:	6.6	→
14:	6.1	←
15:	6.9	↓
16:	10.2x	↖
17:	7.8	↗
18:	5.0	↑
19:	1.3	←
20:	7.9	→
<b>Serie</b>	<b>66</b>	
<b>Total</b>	<b>0</b>	

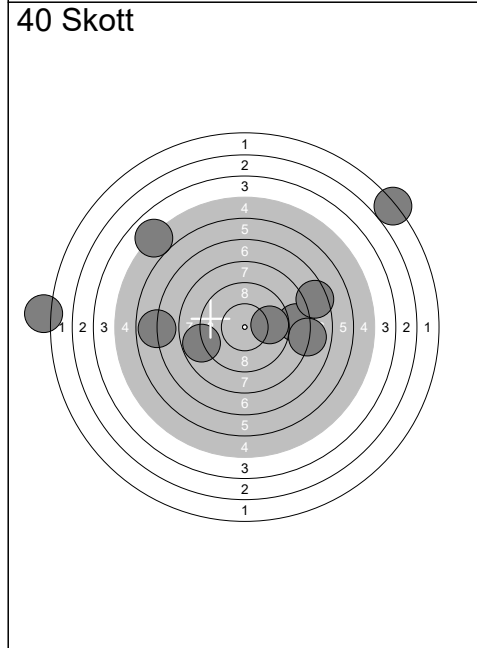

1:	5.0	↖
2:	1.5	←
3:	8.8	←
4:	8.5	→
5:	0.0	←
6:	6.8	←
7:	7.4	→
8:	8.0	→
9:	2.0	↗
10:	9.8	→
<b>Serie</b>	<b>54</b>	
<b>Total</b>	<b>54</b>	

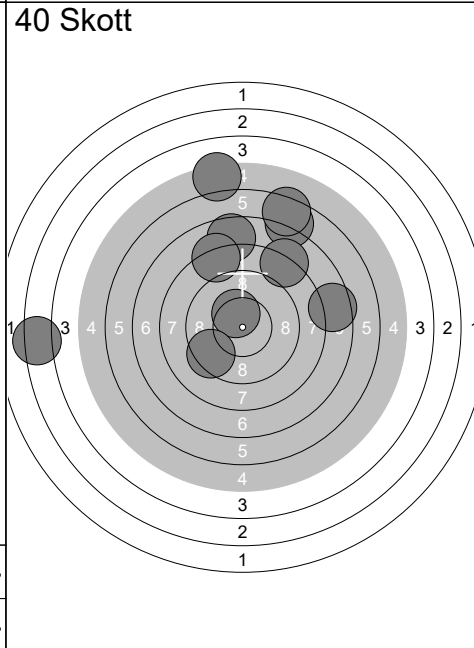

11:	7.6	↑
12:	10.4x	↖
13:	3.3	←
14:	9.4	↖
15:	6.7	↗
16:	8.1	↗
17:	7.5	→
18:	5.3	↑
19:	8.2	↖
20:	6.3	↖
<b>Serie</b>	<b>69</b>	
<b>Total</b>	<b>123</b>	

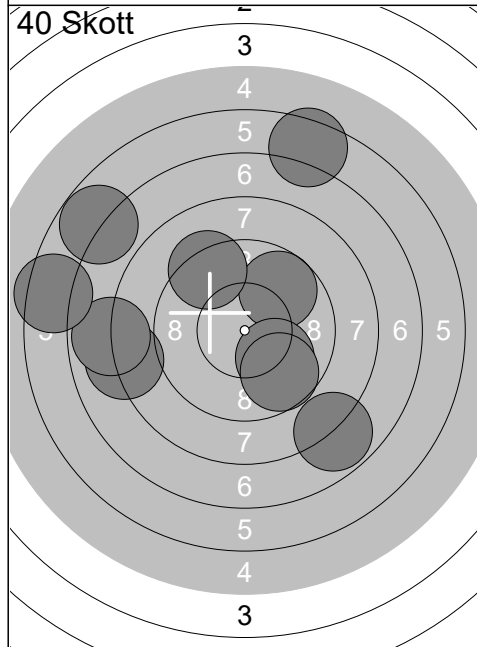

21:	9.8	↗
22:	8.1	←
23:	10.0	↘
24:	9.7	↘
25:	9.3	↗
26:	7.9	←
27:	7.8	↘
28:	6.4	←
29:	6.5	↗
30:	6.8	↖
<b>Serie</b>	<b>77</b>	
<b>Total</b>	<b>200</b>	

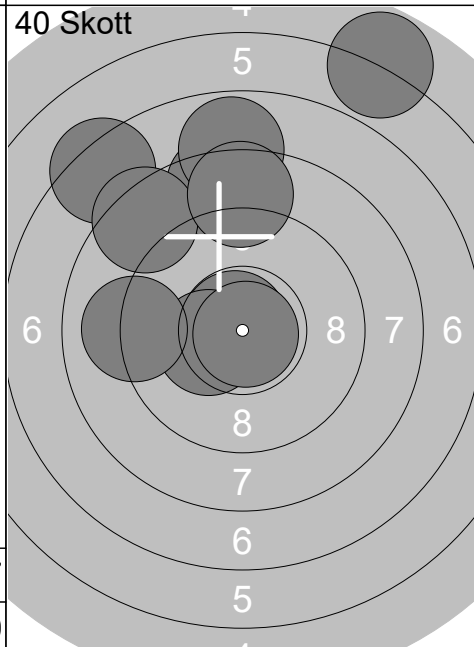

31:	10.8x	↖
32:	10.3x	←
33:	10.9x	↘
34:	5.8	↗
35:	7.3	↖
36:	8.4	↑
37:	8.4	↖
38:	9.1	←
39:	7.8	↑
40:	8.6	↑
<b>Serie</b>	<b>82</b>	
<b>Total</b>	<b>282</b>	

Skjutlag	Tavla	Johan Utsi Häggrud		
2	28	Ramselefors	Gällivare	11
03.11.2019		Vindelnskyttet 2019		No
<b>Prov</b> 	1: 10.1 ↖	<b>Prov</b> 	11: 10.1 ↘	
	2: 10.8x ↓		12: 9.8 ➡	
	3: 10.5x →		13: 10.3x ↗	
	4: 10.9x ↗		14: 10.7x →	
	5: 10.9x ↗			
	6: 10.1 ↘			
	7: 10.0 ↗			
	8: 10.3x ↗			
	9: 10.7x →			
	10: 9.7 ←			
	<b>Serie</b> 99		<b>Serie</b> 39	
	<b>Total</b> 0		<b>Total</b> 0	
<b>40 Skott</b> 	1: 10.5x ↓	<b>40 Skott</b> 	11: 10.4x ↗	
	2: 10.6x ↓		12: 10.4x ↗	
	3: 10.3x ↘		13: 10.6x →	
	4: 10.2x →		14: 10.9x ↓	
	5: 10.3x ↙		15: 10.1 ↘	
	6: 10.2x ↑		16: 10.6x ➡	
	7: 10.7x ↗		17: 10.6x ↓	
	8: 10.3x ↓		18: 10.3x →	
	9: 10.3x ↓		19: 10.4x ↗	
	10: 10.6x ↘		20: 10.7x ↘	
	<b>Serie</b> 100		<b>Serie</b> 100	
	<b>Total</b> 100		<b>Total</b> 200	
<b>40 Skott</b> 	21: 10.9x ↙	<b>40 Skott</b> 	31: 10.6x ↑	
	22: 10.5x ↙		32: 10.6x ↗	
	23: 10.4x ↓		33: 10.3x ↑	
	24: 10.5x ↗		34: 10.9x ➡	
	25: 10.4x ↑		35: 10.4x →	
	26: 10.1 →		36: 10.9x ↗	
	27: 9.8 ↗		37: 10.5x ↗	
	28: 10.0 ↖		38: 10.7x ↗	
	29: 10.7x ↘		39: 10.6x ↑	
	30: 10.3x ↗		40: 10.3x →	
	<b>Serie</b> 99		<b>Serie</b> 100	
	<b>Total</b> 299		<b>Total</b> 399	

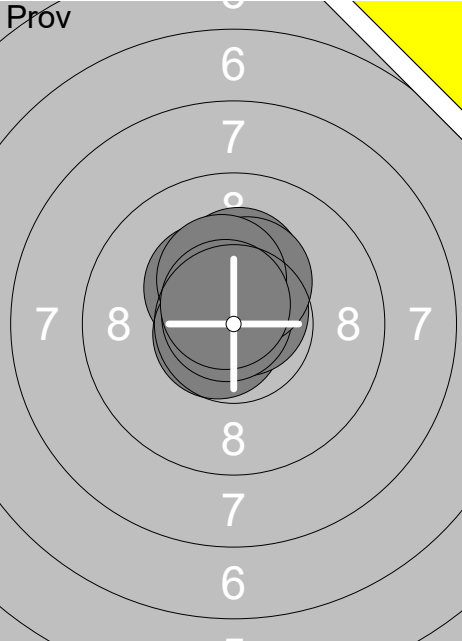
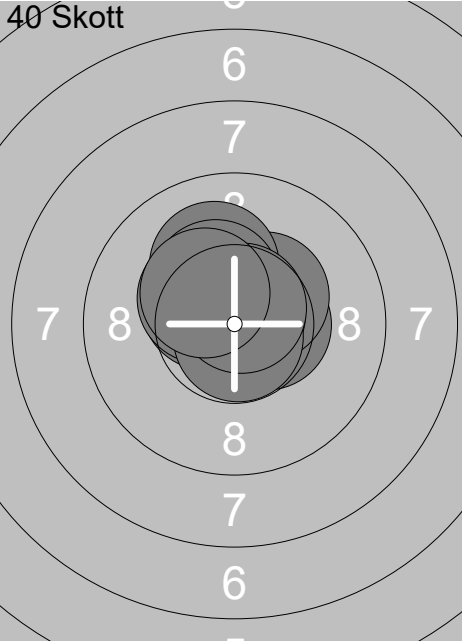
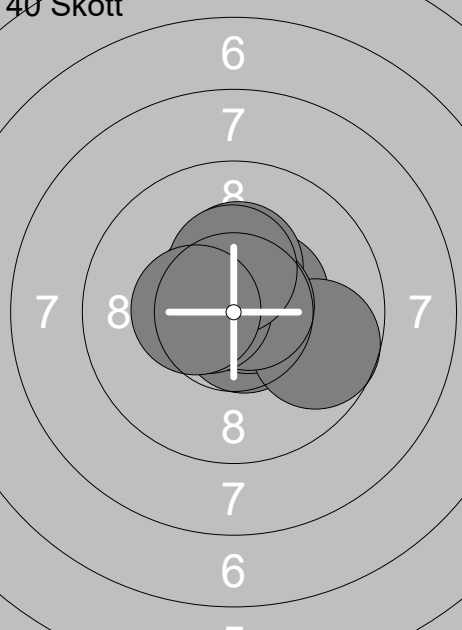
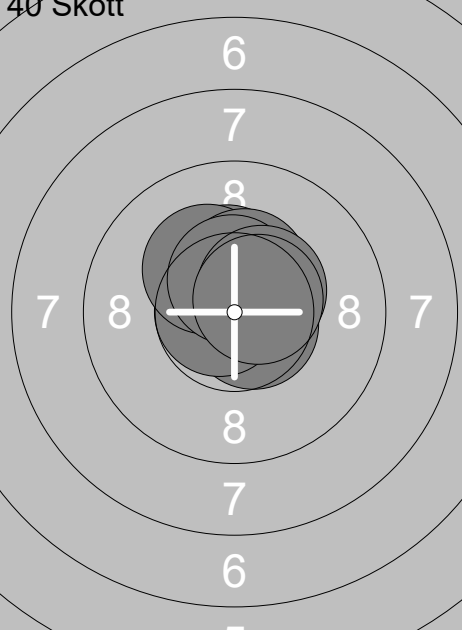
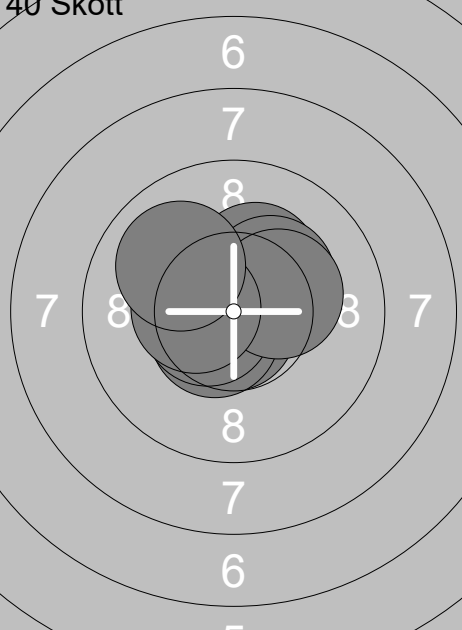
Skjutlag <b>2</b>	Tavla <b>29</b>	<b>Gabriella Nilsson Rova</b>		
Ramselefors	Gällivare	11	No	
03.11.2019	Vindelnskyttet 2019	Ramselefors SKF		
<b>Prov</b> 	1: 10.3x ↖ 2: 10.3x ↑ 3: 10.7x ↙ 4: 10.2x ↑ 5: 10.7x ↗ 6: 10.8x ↖ 7: 10.3x ↑ 8: 10.3x ↑ 9: 10.6x ↖	<b>40 Skott</b> 	1: 10.5x → 2: 10.5x ↖ 3: 10.4x ↗ 4: 10.8x ↗ 5: 10.4x ↖ 6: 10.8x ↓ 7: 10.1 ↑ 8: 10.3x ↖ 9: 10.7x ↗ 10: 10.4x ↖	
	Serie 90		Serie 100	
	Total 0		Total 100	
<b>40 Skott</b> 	11: 10.5x ↗ 12: 10.7x ↓ 13: 10.6x ↖ 14: 10.3x ↑ 15: 10.7x → 16: 9.7 → 17: 10.7x ↗ 18: 10.6x ← 19: 10.4x ↑ 20: 10.4x ←	<b>40 Skott</b> 	21: 10.7x ↑ 22: 10.5x ↑ 23: 10.6x ↘ 24: 10.7x ← 25: 10.3x ↑ 26: 10.2x ↖ 27: 10.4x ↑ 28: 10.5x ↑ 29: 10.5x ↗ 30: 10.6x ↗	
	Serie 99		Serie 100	
	Total 199		Total 299	
<b>40 Skott</b> 	31: 10.8x ↑ 32: 10.7x ↓ 33: 10.5x ↖ 34: 10.6x ↙ 35: 10.6x ← 36: 10.3x ↗ 37: 10.3x ↗ 38: 10.3x → 39: 10.4x ← 40: 10.0 ↖			
	Serie 100			
	Total 399			

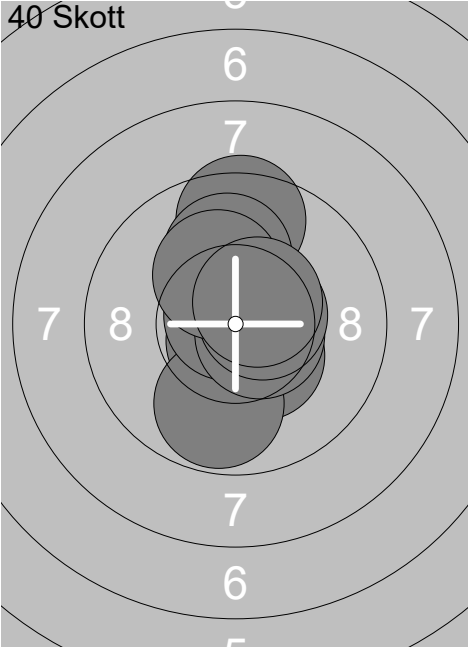
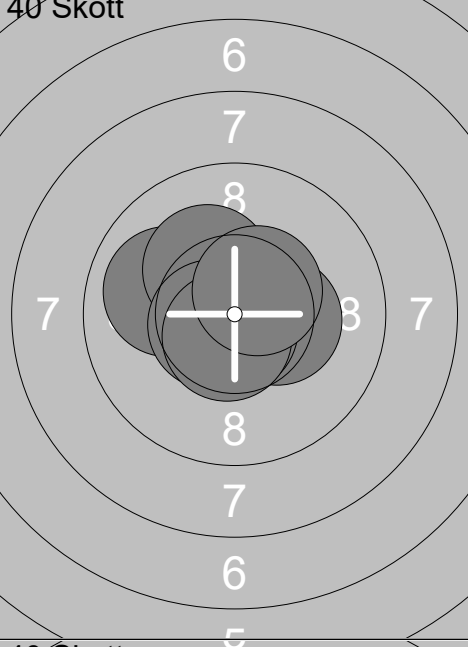
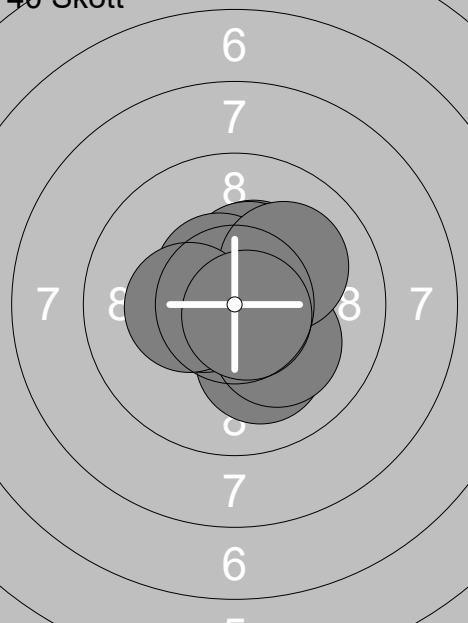
Skjutlag	Tavla	Lennart Westermark	
2	30		
Ramselefors	Drängsmark	Sitt	Vb
03.11.2019	Vindelnskyttet 2019	Ramselefors SKF	
<b>Prov</b> 	1: 10.4x ↘ 2: 10.7x ↘ 3: 10.5x ↓ 4: 10.1 ↖ 5: 10.3x ↖ 6: 9.7 ↑ 7: 10.2x ↑ 8: 9.2 ↗ 9: 9.7 → 10: 10.7x ← <b>Serie 97</b> <b>Total 0</b>	<b>40 Skott</b> 	1: 10.7x ↓ 2: 10.4x ↘ 3: 9.8 ↓ 4: 10.8x ↖ 5: 10.6x → 6: 9.5 ↑ 7: 10.6x → 8: 10.0 ↑ 9: 10.2x ↑ 10: 10.5x ↗ <b>Serie 98</b> <b>Total 98</b>
<b>40 Skott</b> 	11: 10.6x ↑ 12: 10.4x ↖ 13: 10.4x → 14: 10.4x ↖ 15: 10.0 ← 16: 10.7x ↓ 17: 10.2x ↖ 18: 10.6x ↖ 19: 10.6x ↓ 20: 10.5x ↗ <b>Serie 100</b> <b>Total 198</b>	<b>40 Skott</b> 	21: 10.4x → 22: 10.8x ↘ 23: 10.1 ↖ 24: 10.6x ↖ 25: 9.5 ↑ 26: 9.8 → 27: 10.6x ↓ 28: 10.5x → 29: 10.4x ↘ 30: 9.8 ↑ <b>Serie 97</b> <b>Total 295</b>
<b>40 Skott</b> 	31: 10.5x ↗ 32: 10.3x ↗ 33: 10.1 ↓ 34: 10.4x ↑ 35: 10.2x ↘ 36: 10.5x ← 37: 10.5x ↖ 38: 10.1 ↗ 39: 10.3x ← 40: 10.7x ↘ <b>Serie 100</b> <b>Total 395</b>		

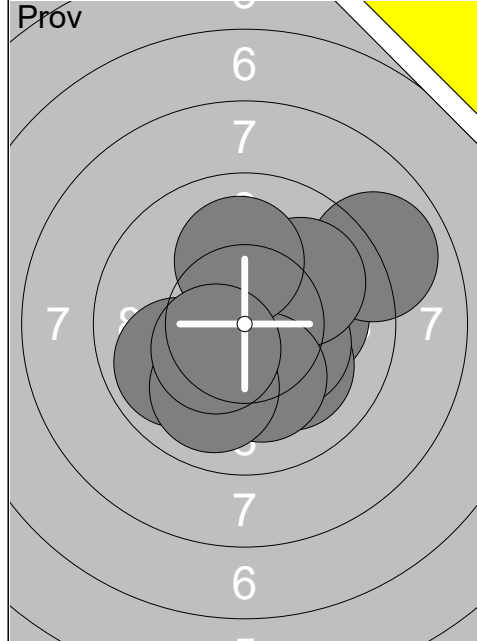

1:	10.1	→
2:	8.9	→
3:	10.1	↘
4:	10.3x	→
5:	10.0	↗
6:	9.9	←
7:	10.2x	↓
8:	10.0	↓
9:	10.1	↑
10:	10.4x	↙
Serie		100.0
Total		0.0

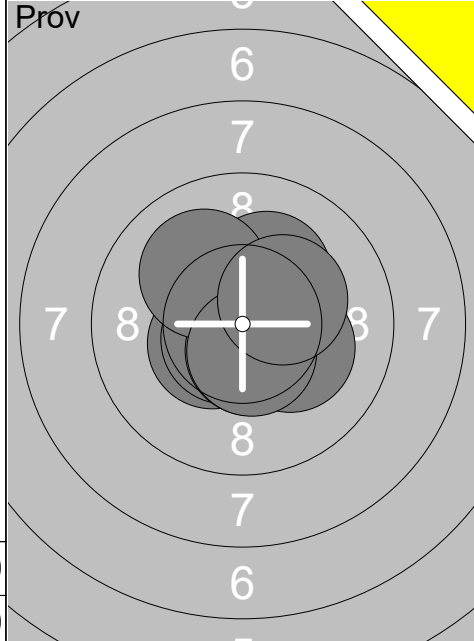

11:	10.7x	↗
12:	10.4x	↙
13:	10.6x	↙
14:	10.2x	↗
15:	10.2x	→
16:	10.6x	↓
17:	10.1	↖
18:	10.6x	↓
19:	10.3x	↗
Serie		93.7
Total		0.0

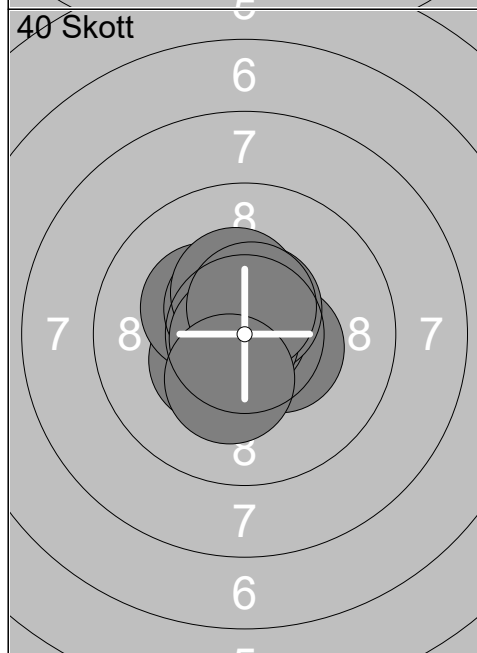

1:	10.4x	↙
2:	10.3x	↖
3:	10.4x	→
4:	10.9x	↖
5:	10.5x	↖
6:	10.6x	↗
7:	10.4x	↑
8:	10.8x	↙
9:	10.6x	↑
10:	10.3x	↓
Serie		105.2
Total		105.2

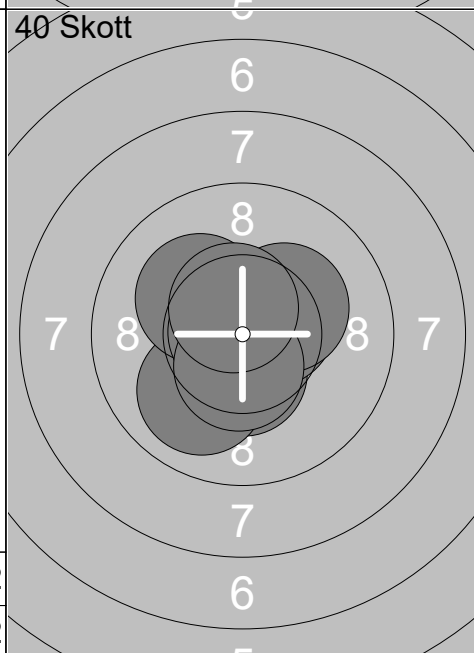

11:	10.4x	↓
12:	10.0	↓
13:	10.6x	↖
14:	10.2x	↖
15:	10.8x	↓
16:	10.8x	↙
17:	10.5x	↗
18:	10.3x	↗
19:	10.5x	↓
20:	10.6x	↑
Serie		104.7
Total		209.9

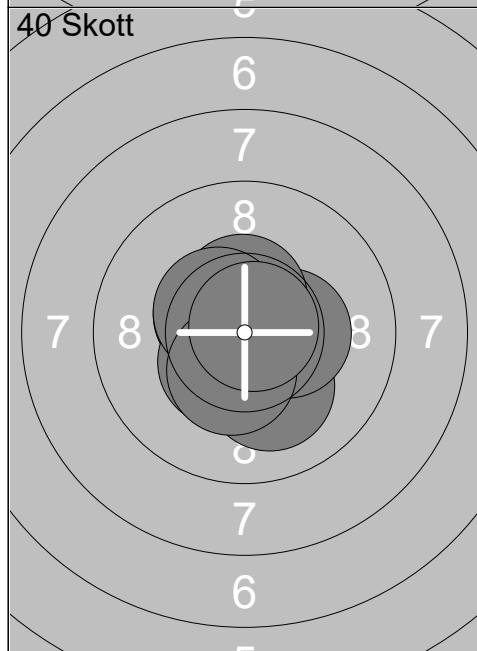

21:	10.5x	↖
22:	10.4x	↓
23:	10.1	↓
24:	10.9x	↓
25:	10.4x	↙
26:	10.4x	→
27:	10.5x	↑
28:	10.5x	↖
29:	10.4x	↓
30:	10.8x	↗
Serie		104.9
Total		314.8

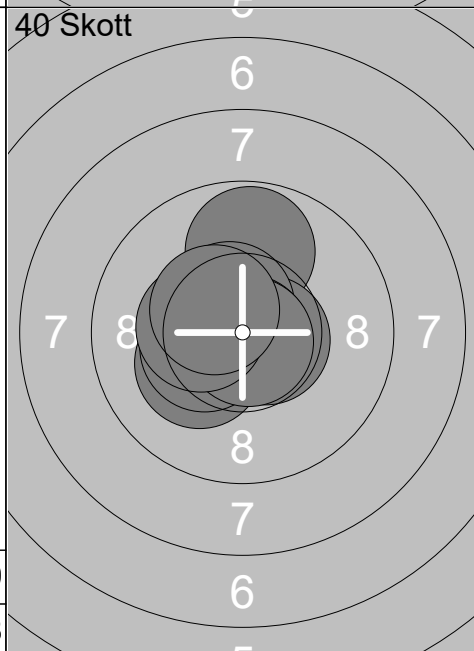

31:	10.2x	↙
32:	9.8	↑
33:	10.4x	↙
34:	10.6x	↖
35:	10.6x	→
36:	10.5x	↖
37:	10.8x	↓
38:	10.8x	↓
39:	10.4x	↙
40:	10.4x	↖
Serie		104.5
Total		419.3

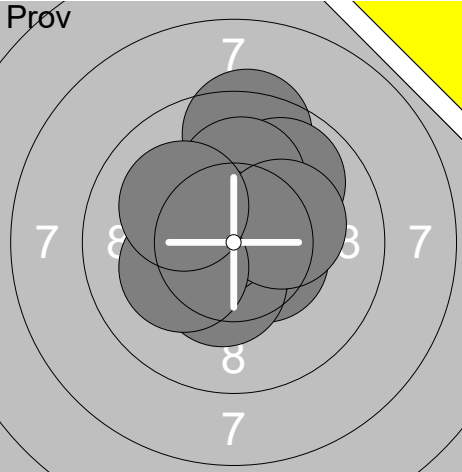
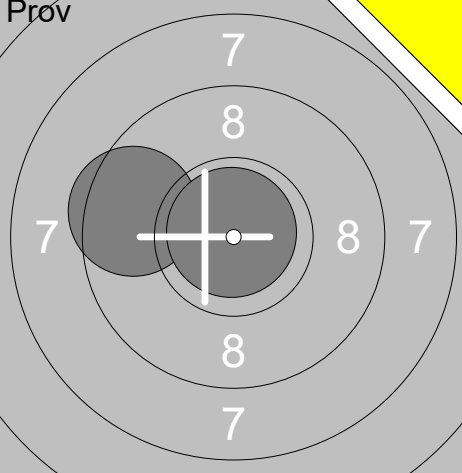
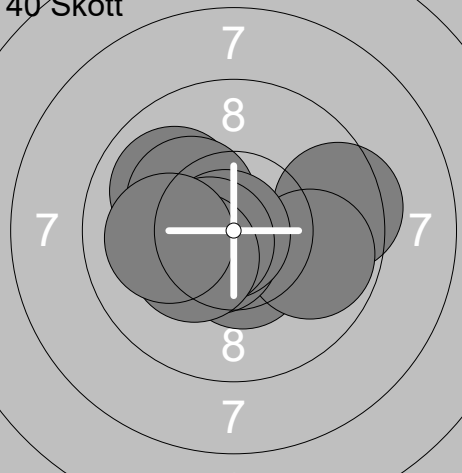
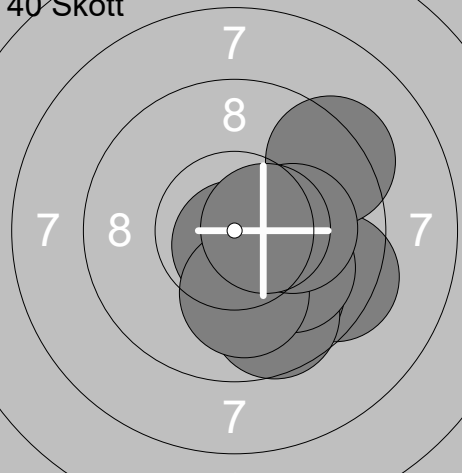
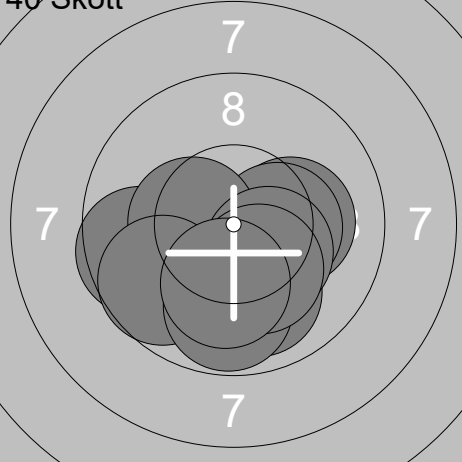

Skjutlag <b>2</b>	Tavla <b>32</b>	<b>Nils Fredriksson</b>			
Ramselefors		Umeå		Sitt	Vb
03.11.2019		Vindelnskyttet 2019		Ramselefors SKF	
<b>Prov</b> 	1: 9.4 ↑ 2: 9.9 ↗ 3: 10.5x → 4: 10.1 ↑ 5: 10.8x ↓ 6: 10.4x ↓ 7: 10.6x ↗ 8: 10.2x → 9: 10.2x ← 10: 10.1 ↖ Serie 102.2 Total 0.0	<b>Prov</b> 	11: 10.5x ← 12: 10.4x ↘ 13: 10.7x ↗ 14: 10.1 ↑ 15: 10.0 ↓ 16: 10.1 ↑ 17: 10.7x ↓ 18: 9.9 → 19: 9.8 ↗ 20: 10.0 ← Serie 102.2 Total 0.0		
<b>Prov</b> 	21: 9.5 ← 22: 10.9x ↗ Serie 20.4 Total 0.0	<b>40 Skott</b> 	1: 10.7x → 2: 10.0 → 3: 10.5x ↓ 4: 10.4x ↓ 5: 10.6x ↓ 6: 10.2x → 7: 9.9 ↓ 8: 10.3x → 9: 10.6x → 10: 10.6x → Serie 103.8 Total 103.8		
<b>40 Skott</b> 	11: 10.5x ↓ 12: 10.0 ↗ 13: 9.5 → 14: 9.8 → 15: 10.6x ↓ 16: 10.2x ↗ 17: 10.8x ← 18: 10.6x ← 19: 10.3x ← 20: 10.0 ← Serie 102.3 Total 206.1	<b>40 Skott</b> 	21: 9.4 → 22: 9.3 ↗ 23: 10.8x ↓ 24: 10.1 ↓ 25: 9.9 ↓ 26: 9.7 ↓ 27: 10.0 ↓ 28: 10.1 ↓ 29: 10.1 → 30: 10.5x → Serie 99.9 Total 306.0		
<b>40 Skott</b> 	31: 10.2x → 32: 9.6 ← 33: 10.3x → 34: 10.0 ↓ 35: 10.4x ← 36: 9.7 ↓ 37: 9.8 ↓ 38: 10.3x ↘ 39: 10.2x ↓ 40: 10.1 ↓ Serie 100.6 Total 406.6				

Skjutlag	Tavla	Erika Augustsson	
2	33		
Ramselefors	Vännäs	Sitt	Vb
03.11.2019	Vindelnskytten 2019	Ramselefors SKF	
<b>Prov</b> 	1: 9.3 ↘ 2: 10.3x → 3: 9.9 ↙ 4: 10.7x → 5: 9.6 ↙ 6: 10.6x ↓ 7: 10.7x ↙ 8: 10.7x ↓ 9: 10.7x ↙ 10: 10.2x ↑	<b>Prov</b> 	11: 10.3x ↘ 12: 10.6x ↙
	Serie 97		Serie 20
	Total 0		Total 0
<b>40 Skott</b> 	1: 10.4x ↙ 2: 10.8x → 3: 10.6x ↘ 4: 10.4x ↑ 5: 10.7x ↓ 6: 10.8x ↑ 7: 10.8x ↓ 8: 10.7x ↘ 9: 10.3x ↙ 10: 10.2x ↓	<b>40 Skott</b> 	11: 10.8x ↙ 12: 10.6x ↓ 13: 10.5x ↑ 14: 10.7x ↙ 15: 10.6x ↘ 16: 10.6x ↑ 17: 10.8x → 18: 10.5x ↓ 19: 10.6x ↘ 20: 10.7x ↑
	Serie 100		Serie 100
	Total 100		Total 200
<b>40 Skott</b> 	21: 10.8x ↘ 22: 10.8x ↙ 23: 10.6x ↓ 24: 10.8x ↗ 25: 10.6x ↙ 26: 10.6x ↘ 27: 10.7x → 28: 10.7x ↘ 29: 10.4x ↙ 30: 10.7x ↘	<b>40 Skott</b> 	31: 10.6x ↘ 32: 10.4x ↙ 33: 10.5x ↙ 34: 10.7x ↗ 35: 10.6x ↘ 36: 10.6x ↗ 37: 10.9x ↙ 38: 10.4x ↗ 39: 10.4x → 40: 10.7x →
	Serie 100		Serie 100
	Total 300		Total 400

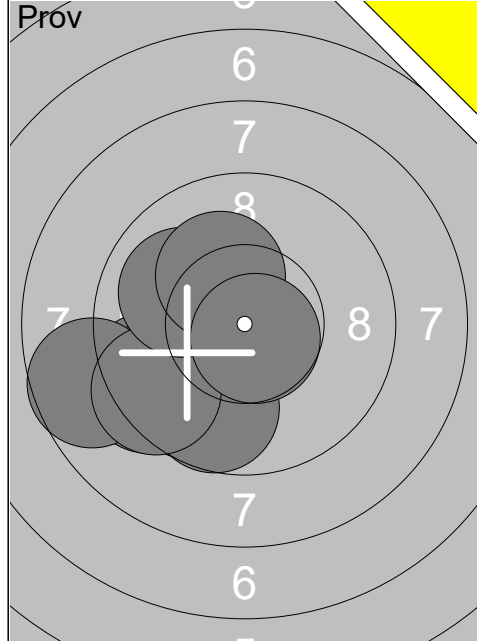

1:	9.7	↘
2:	10.0	←
3:	9.5	←
4:	9.3	←
5:	8.7	←
6:	9.7	↘
7:	9.4	←
8:	10.0	↖
9:	10.2x	↗
10:	10.7x	↘
<b>Serie</b>		<b>93</b>
<b>Total</b>		<b>0</b>

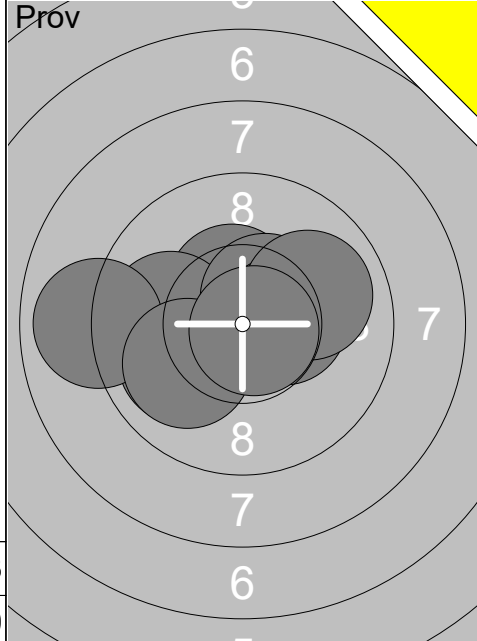

11:	10.6x	←
12:	10.4x	↗
13:	10.0	←
14:	9.9	←
15:	8.9	←
16:	10.0	↘
17:	10.5x	↗
18:	10.4x	→
19:	10.0	↗
20:	10.8x	↘
<b>Serie</b>		<b>97</b>
<b>Total</b>		<b>0</b>

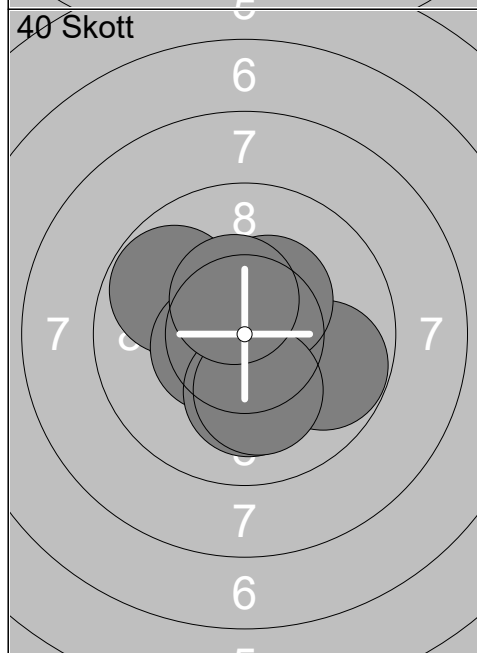

1:	10.5x	←
2:	9.8	↖
3:	10.5x	←
4:	10.3x	↘
5:	10.3x	↘
6:	10.1	↓
7:	9.8	→
8:	10.4x	↗
9:	10.1	↓
10:	10.4x	↗
<b>Serie</b>		<b>98</b>
<b>Total</b>		<b>98</b>

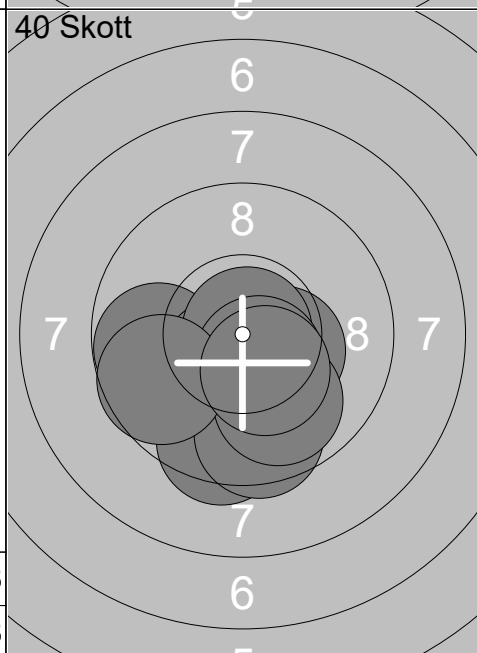

11:	9.4	↓
12:	10.4x	→
13:	9.8	←
14:	10.5x	↘
15:	10.9x	↗
16:	9.6	↓
17:	9.9	↓
18:	10.5x	↘
19:	9.7	←
20:	10.4x	↘
<b>Serie</b>		<b>95</b>
<b>Total</b>		<b>193</b>

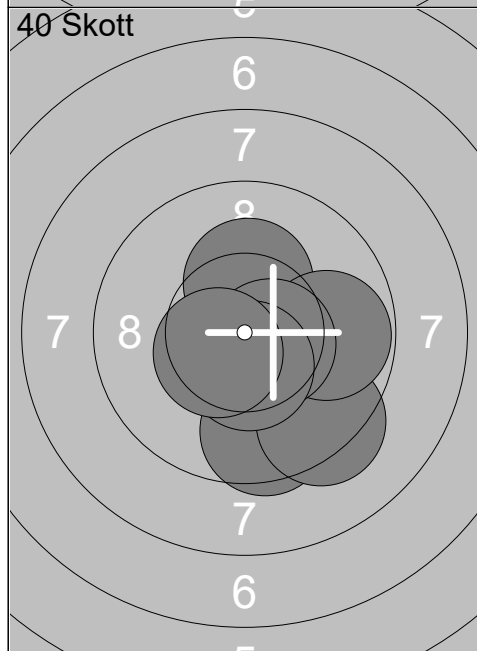

21:	9.6	↓
22:	10.1	→
23:	10.6x	↓
24:	10.3x	↑
25:	10.2x	→
26:	9.3	↘
27:	9.8	→
28:	10.5x	→
29:	10.5x	↓
30:	10.5x	↘
<b>Serie</b>		<b>97</b>
<b>Total</b>		<b>290</b>

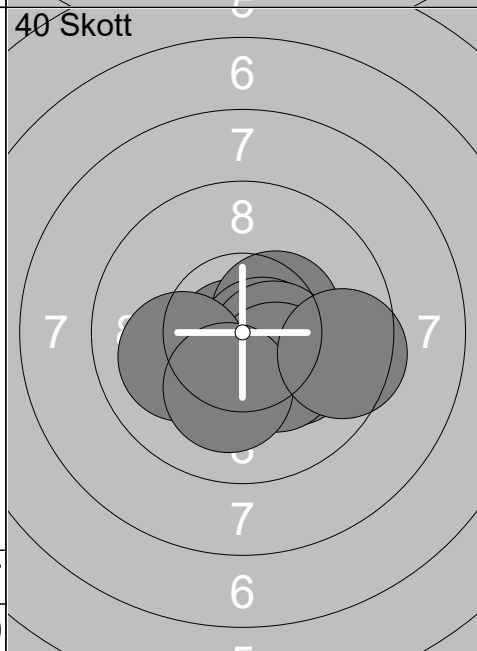

31:	10.5x	↓
32:	10.8x	↘
33:	10.2x	→
34:	10.4x	↗
35:	10.6x	→
36:	10.5x	→
37:	10.3x	↘
38:	10.1	←
39:	10.2x	↓
40:	9.5	→
<b>Serie</b>		<b>99</b>
<b>Total</b>		<b>389</b>

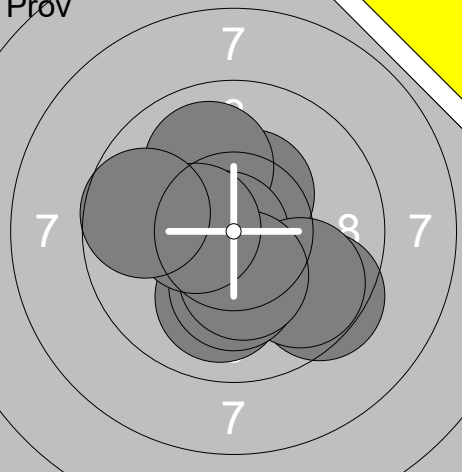
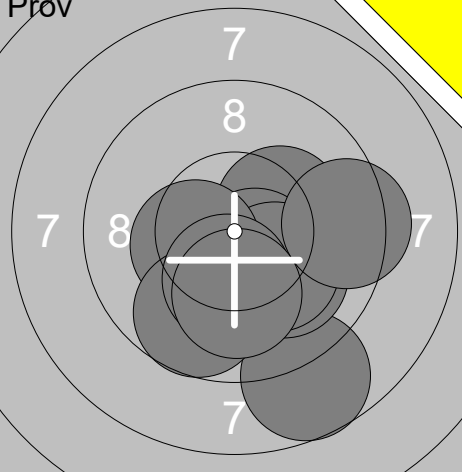
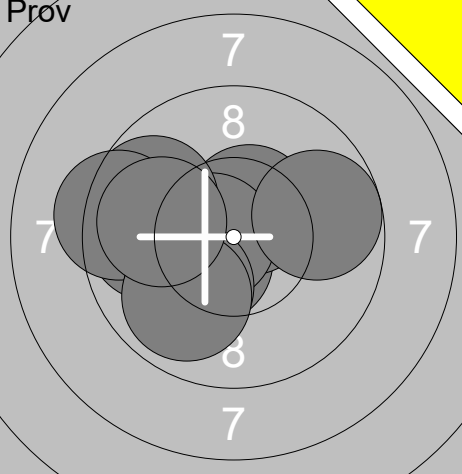
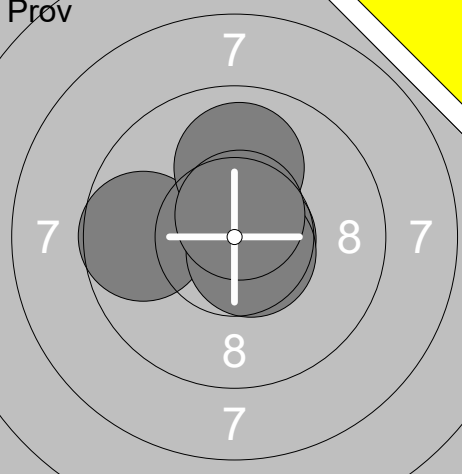
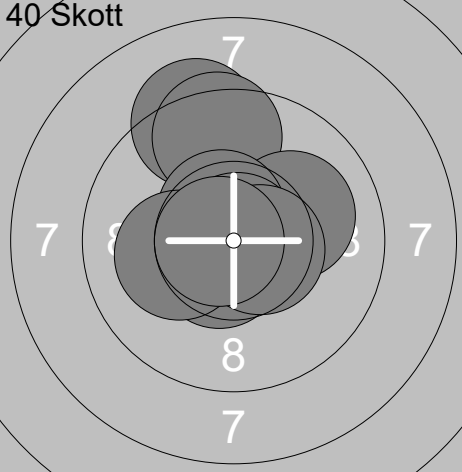
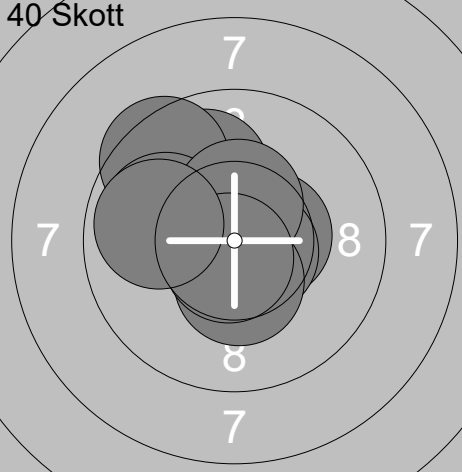
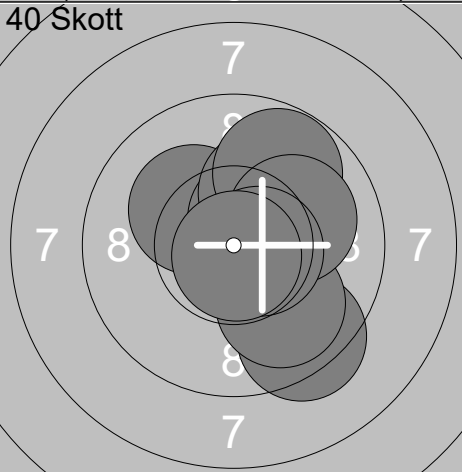
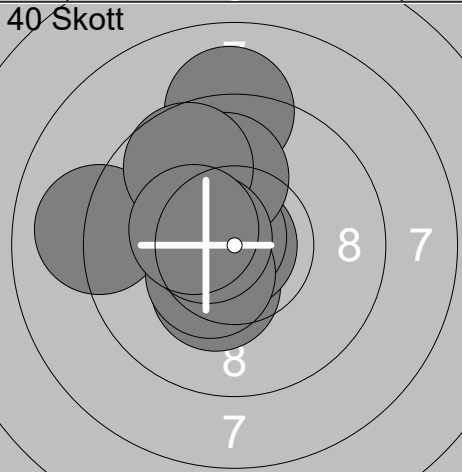
<b>Prov</b> 	1: 10.4x ↗ 2: 10.0 ↗ 3: 10.8x ↖ 4: 9.5 ↘ 5: 9.8 ↘ 6: 10.0 ↘ 7: 10.2x ↘ 8: 10.3x ↘ 9: 10.4x ↖ 10: 9.7 ↖ <hr/> Serie 97 Total 0	<b>Prov</b> 	11: 10.3x → 12: 8.7 ↘ 13: 10.1 ↘ 14: 10.5x ↘ 15: 10.2x ↘ 16: 10.4x ↖ 17: 9.7 ↘ 18: 9.4 → 19: 10.3x ↘ 20: 10.1 ↘ <hr/> Serie 96 Total 0
<b>Prov</b> 	21: 10.5x ↘ 22: 10.5x ↗ 23: 10.6x ↖ 24: 9.8 → 25: 9.7 ↖ 26: 9.8 ↖ 27: 9.3 ↖ 28: 10.0 ↘ 29: 9.9 ↘ 30: 9.9 ↖ <hr/> Serie 94 Total 0	<b>Prov</b> 	31: 9.7 ↖ 32: 10.7x → 33: 10.0 ↗ 34: 10.6x ↘ 35: 10.6x ↗ <hr/> Serie 49 Total 0
<b>40 Skott</b> 	1: 9.2 ↗ 2: 10.8x ↖ 3: 9.5 ↗ 4: 10.1 → 5: 10.6x ↗ 6: 10.9x ↗ 7: 10.6x ↘ 8: 10.2x ↖ 9: 10.6x → 10: 10.7x ↖ <hr/> Serie 98 Total 98	<b>40 Skott</b> 	11: 9.9 ↗ 12: 10.5x → 13: 9.5 ↗ 14: 10.6x ↘ 15: 10.4x ↘ 16: 10.3x ↖ 17: 9.9 ↖ 18: 10.4x ↗ 19: 10.7x ↘ 20: 9.9 ↖ <hr/> Serie 96 Total 194
<b>40 Skott</b> 	21: 9.4 ↘ 22: 10.2x ↗ 23: 9.9 ↘ 24: 10.1 ↗ 25: 10.5x ↗ 26: 10.1 ↗ 27: 9.8 ↗ 28: 10.1 → 29: 10.6x → 30: 10.8x ↘ <hr/> Serie 97 Total 291	<b>40 Skott</b> 	31: 10.3x ↘ 32: 10.9x ↖ 33: 9.1 ↗ 34: 9.1 ↖ 35: 10.7x ↗ 36: 10.4x ↖ 37: 10.0 ↗ 38: 9.7 ↗ 39: 10.6x ↖ 40: 10.3x ↖ <hr/> Serie 97 Total 388

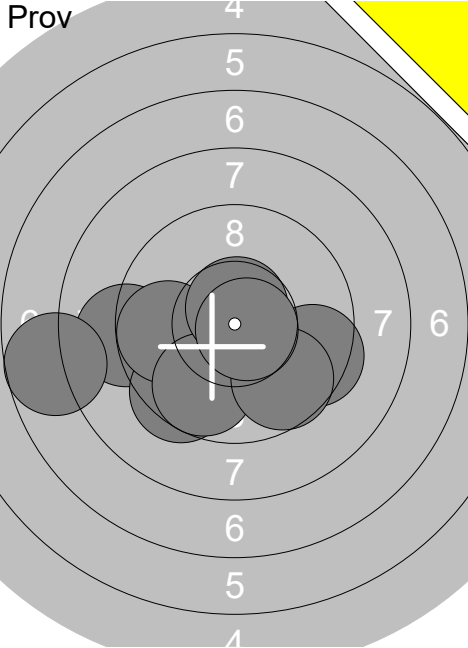
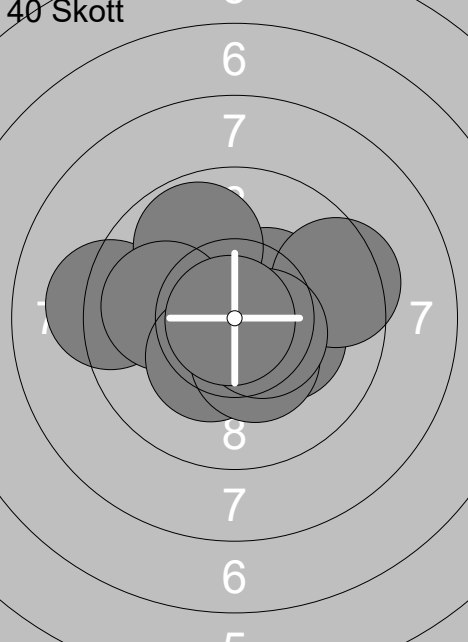
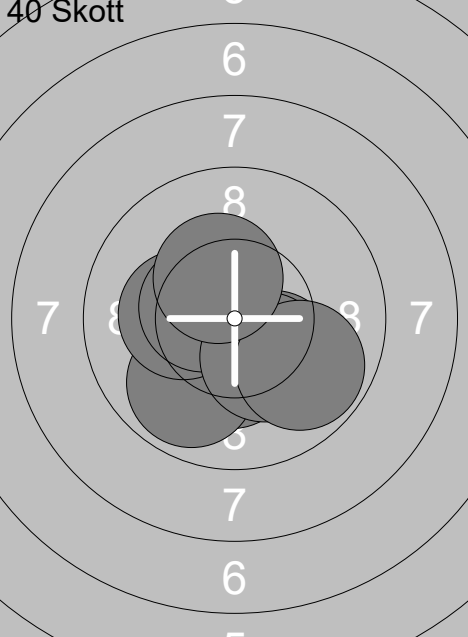
Skjuttag	Tavla	Clas-Göran Lundell																			
2	38	Ramselefors	Ramselefors	Funk	Vb																
03.11.2019	Vindelnskyttet 2019	Ramselefors SKF																			
Prov		1: 9.0 ←	2: 10.3x ↘	3: 9.4 ↘	4: 9.8 ←	5: 9.5 ➔	6: 7.7 ←	7: 9.8 ↘	8: 9.7 ↘	9: 10.7x ↑	10: 10.7x ➔	11: 10.7x ↘	12: 9.1 ↑	13: 10.3x ↖	14: 10.6x ↑	15: 10.0 ↗	16: 10.1 ↙	17: 10.1 ↑			
		Serie 91		Total 0		Serie 69		Total 0													
40 Skott		1: 10.4x ↗	2: 9.2 ←	3: 9.8 ↗	4: 10.0 ←	5: 10.2x ➔	6: 9.5 ➔	7: 10.3x ↘	8: 10.3x ↘	9: 10.5x ➔	10: 10.9x ↙	11: 9.7 ↖	12: 10.1 ↖	13: 10.3x ↑	14: 10.5x ↖	15: 10.1 ➔	16: 9.7 ←	17: 10.5x ↑	18: 9.5 ←	19: 10.3x ↑	20: 10.1 ↗
		Serie 97		Total 97		Serie 97		Total 194													
40 Skott		21: 10.7x ↘	22: 10.2x ↘	23: 10.3x ↘	24: 10.4x ↙	25: 9.9 ↘	26: 10.2x ←	27: 10.5x ←	28: 10.3x ↘	29: 9.8 ↘	30: 10.3x ↗	31: 10.7x ←	32: 9.9 ↗	33: 9.2 ↗	34: 10.4x ↘	35: 9.6 ↘	36: 10.5x ➔	37: 9.7 ↘	38: 10.2x ↖	39: 10.5x ↑	40: 9.9 ←
		Serie 98		Total 292		Serie 95		Total 387													