

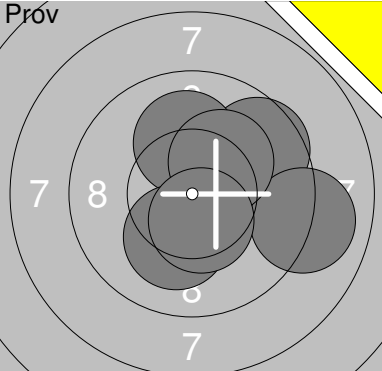

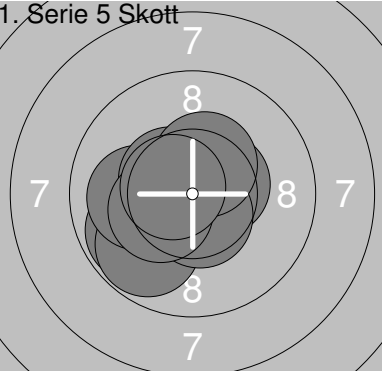

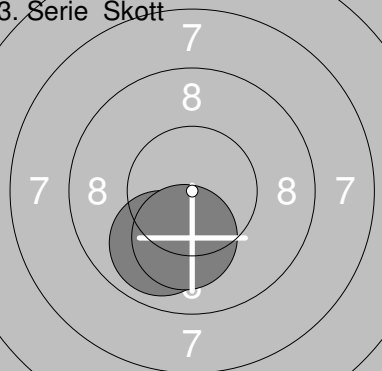



Skjuttlag	Tavla	Lotten Johansson																																																												
2	11																																																													
S	Ramselefors Skf																																																													
05.10.2019	UME-Skottet 2019	Umeå skytteallians																																																												
Pröv	 <table border="1"> <tr><td>1:</td><td>9.6</td><td>↗</td></tr> <tr><td>2:</td><td>9.0</td><td>→</td></tr> <tr><td>3:</td><td>10.1</td><td>↑</td></tr> <tr><td>4:</td><td>10.2x</td><td>↗</td></tr> <tr><td>5:</td><td>10.2x</td><td>↓</td></tr> <tr><td>6:</td><td>10.5x</td><td>↓</td></tr> <tr><td>Serie</td><td>59.6</td><td></td></tr> <tr><td>Total</td><td>0.0</td><td></td></tr> </table>	1:	9.6	↗	2:	9.0	→	3:	10.1	↑	4:	10.2x	↗	5:	10.2x	↓	6:	10.5x	↓	Serie	59.6		Total	0.0		 <table border="1"> <tr><td>1:</td><td>9.8</td><td>↙</td></tr> <tr><td>2:</td><td>10.8x</td><td>←</td></tr> <tr><td>3:</td><td>9.8</td><td>↙</td></tr> <tr><td>4:</td><td>10.0</td><td>←</td></tr> <tr><td>5:</td><td>10.5x</td><td>→</td></tr> <tr><td>6:</td><td>10.5x</td><td>↖</td></tr> <tr><td>7:</td><td>10.6x</td><td>↓</td></tr> <tr><td>8:</td><td>10.3x</td><td>←</td></tr> <tr><td>9:</td><td>10.4x</td><td>↑</td></tr> <tr><td>10:</td><td>10.6x</td><td>↙</td></tr> <tr><td>Serie</td><td>103.3</td><td></td></tr> <tr><td>Total</td><td>103.3</td><td></td></tr> </table>	1:	9.8	↙	2:	10.8x	←	3:	9.8	↙	4:	10.0	←	5:	10.5x	→	6:	10.5x	↖	7:	10.6x	↓	8:	10.3x	←	9:	10.4x	↑	10:	10.6x	↙	Serie	103.3		Total	103.3	
1:	9.6	↗																																																												
2:	9.0	→																																																												
3:	10.1	↑																																																												
4:	10.2x	↗																																																												
5:	10.2x	↓																																																												
6:	10.5x	↓																																																												
Serie	59.6																																																													
Total	0.0																																																													
1:	9.8	↙																																																												
2:	10.8x	←																																																												
3:	9.8	↙																																																												
4:	10.0	←																																																												
5:	10.5x	→																																																												
6:	10.5x	↖																																																												
7:	10.6x	↓																																																												
8:	10.3x	←																																																												
9:	10.4x	↑																																																												
10:	10.6x	↙																																																												
Serie	103.3																																																													
Total	103.3																																																													
3. Serie Skott	 <table border="1"> <tr><td>1:</td><td>9.9</td><td>↓</td></tr> <tr><td>2:</td><td>10.2x</td><td>↓</td></tr> <tr><td>Serie</td><td>20.1</td><td></td></tr> <tr><td>Total</td><td>123.4</td><td></td></tr> </table>	1:	9.9	↓	2:	10.2x	↓	Serie	20.1		Total	123.4		 <table border="1"> <tr><td>1:</td><td>10.5x</td><td>↓</td></tr> <tr><td>2:</td><td>10.6x</td><td>↙</td></tr> <tr><td>Serie</td><td>21.1</td><td></td></tr> <tr><td>Total</td><td>144.5</td><td></td></tr> </table>	1:	10.5x	↓	2:	10.6x	↙	Serie	21.1		Total	144.5																																					
1:	9.9	↓																																																												
2:	10.2x	↓																																																												
Serie	20.1																																																													
Total	123.4																																																													
1:	10.5x	↓																																																												
2:	10.6x	↙																																																												
Serie	21.1																																																													
Total	144.5																																																													
5. Serie Skott	 <table border="1"> <tr><td>1:</td><td>10.6x</td><td>↗</td></tr> <tr><td>2:</td><td>9.8</td><td>↖</td></tr> <tr><td>Serie</td><td>20.4</td><td></td></tr> <tr><td>Total</td><td>164.9</td><td></td></tr> </table>	1:	10.6x	↗	2:	9.8	↖	Serie	20.4		Total	164.9		 <table border="1"> <tr><td>1:</td><td>10.6x</td><td>↙</td></tr> <tr><td>2:</td><td>10.7x</td><td>↑</td></tr> <tr><td>Serie</td><td>21.3</td><td></td></tr> <tr><td>Total</td><td>186.2</td><td></td></tr> </table>	1:	10.6x	↙	2:	10.7x	↑	Serie	21.3		Total	186.2																																					
1:	10.6x	↗																																																												
2:	9.8	↖																																																												
Serie	20.4																																																													
Total	164.9																																																													
1:	10.6x	↙																																																												
2:	10.7x	↑																																																												
Serie	21.3																																																													
Total	186.2																																																													
7. Serie Skott	 <table border="1"> <tr><td>1:</td><td>10.1</td><td>↗</td></tr> <tr><td>2:</td><td>10.7x</td><td>↗</td></tr> <tr><td>Serie</td><td>20.8</td><td></td></tr> <tr><td>Total</td><td>207.0</td><td></td></tr> </table>	1:	10.1	↗	2:	10.7x	↗	Serie	20.8		Total	207.0		 <table border="1"> <tr><td>1:</td><td>10.4x</td><td>↓</td></tr> <tr><td>2:</td><td>10.2x</td><td>↑</td></tr> <tr><td>Serie</td><td>20.6</td><td></td></tr> <tr><td>Total</td><td>227.6</td><td></td></tr> </table>	1:	10.4x	↓	2:	10.2x	↑	Serie	20.6		Total	227.6																																					
1:	10.1	↗																																																												
2:	10.7x	↗																																																												
Serie	20.8																																																													
Total	207.0																																																													
1:	10.4x	↓																																																												
2:	10.2x	↑																																																												
Serie	20.6																																																													
Total	227.6																																																													
9. Serie Skott	 <table border="1"> <tr><td>1:</td><td>10.2x</td><td>↖</td></tr> <tr><td>2:</td><td>9.9</td><td>↙</td></tr> <tr><td>Serie</td><td>20.1</td><td></td></tr> <tr><td>Total</td><td>247.7</td><td></td></tr> </table>	1:	10.2x	↖	2:	9.9	↙	Serie	20.1		Total	247.7																																																		
1:	10.2x	↖																																																												
2:	9.9	↙																																																												
Serie	20.1																																																													
Total	247.7																																																													

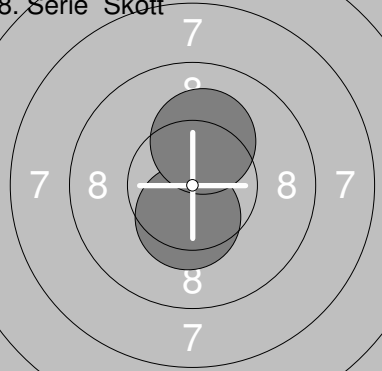
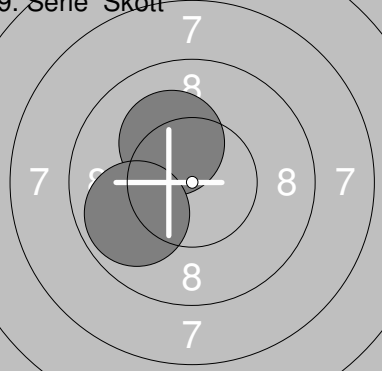
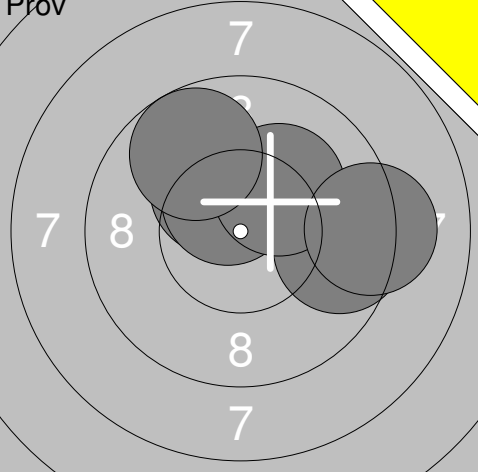
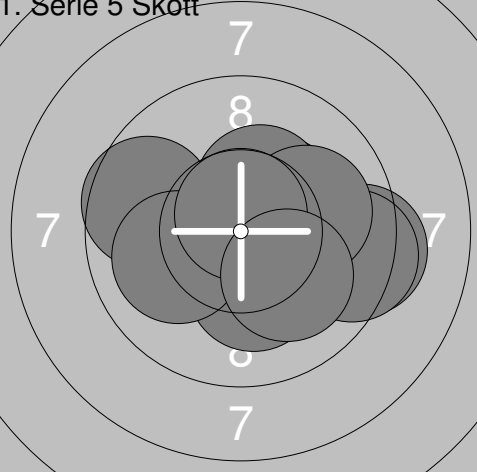
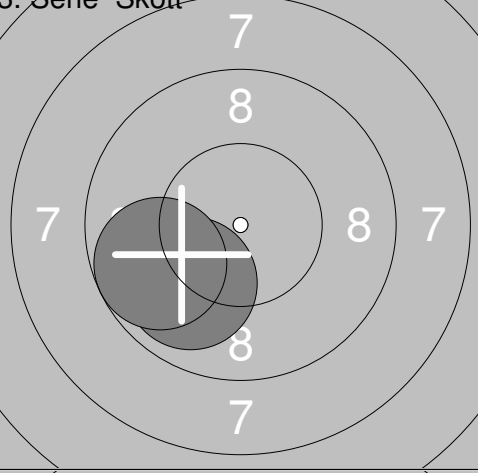
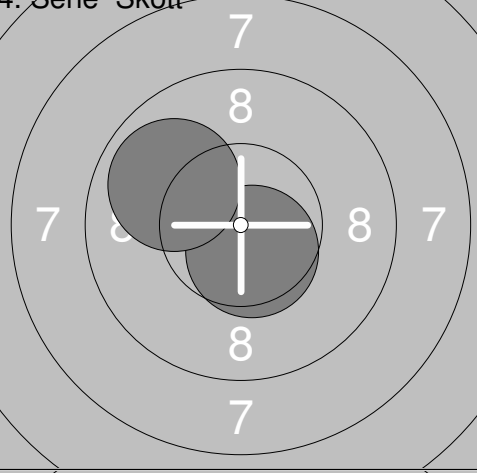
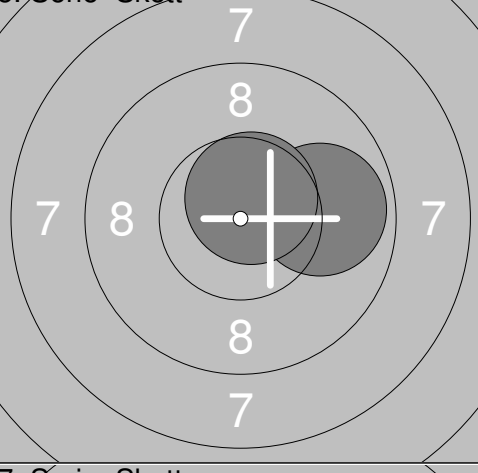
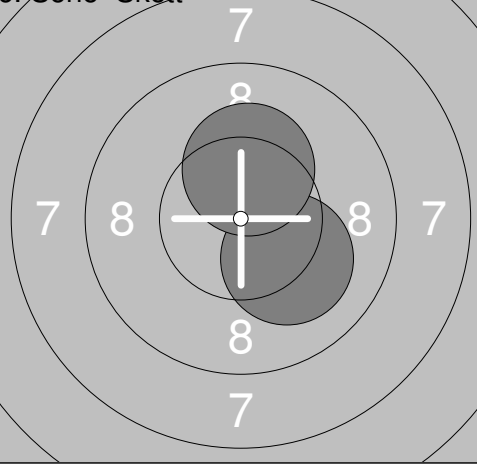

<p>Prov</p>	<p>1: 10.0 ↗</p> <p>2: 10.8x↘</p> <p>3: 9.2 ←</p> <p>4: 10.2x↗</p> <p>5: 8.8 ↗</p>	<p>1. Serie 5 Skott</p>	<p>1: 9.8 ←</p> <p>2: 9.4 ↘</p> <p>3: 9.7 ↗</p> <p>4: 10.2x↘</p> <p>5: 10.0 ↗</p> <p>6: 9.0 →</p> <p>7: 9.4 →</p> <p>8: 10.3x↗</p> <p>9: 10.4x↘</p> <p>10: 10.2x↘</p>
Serie	49.0	Serie	98.4
Total	0.0	Total	98.4

<p>3. Serie Skott</p>	<p>1: 9.3 ↗</p> <p>2: 10.0 ↗</p>	<p>4. Serie Skott</p>	<p>1: 10.0 ↘</p> <p>2: 8.3 →</p>
Serie	19.3	Serie	18.3
Total	117.7	Total	136.0

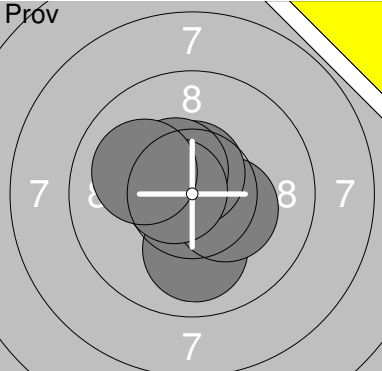
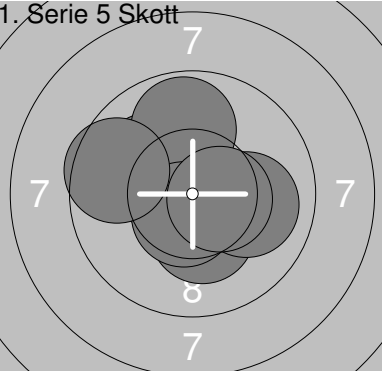
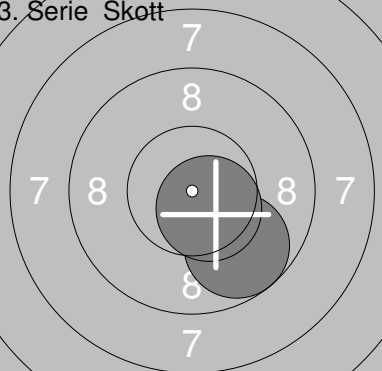
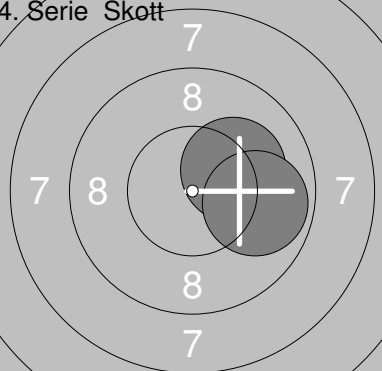
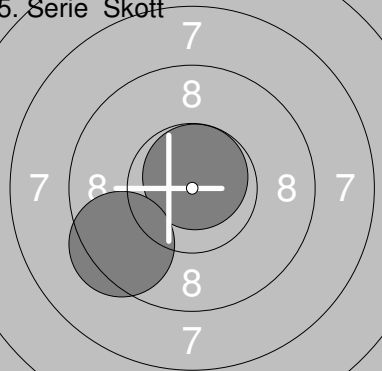
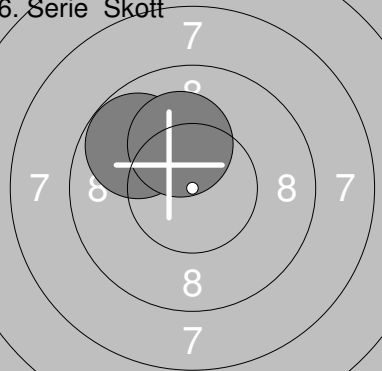

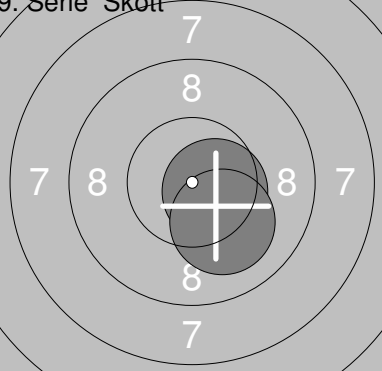
<p>5. Serie Skott</p>	<p>1: 10.1 ↘</p> <p>2: 10.5x↘</p>	<p>6. Serie Skott</p>	<p>1: 9.5 ↘</p> <p>2: 10.4x↘</p>
Serie	20.6	Serie	19.9
Total	156.6	Total	176.5

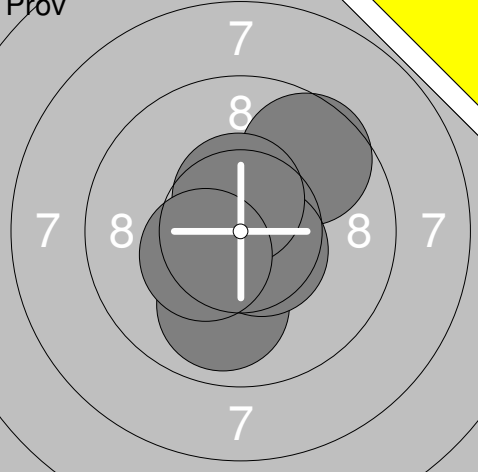
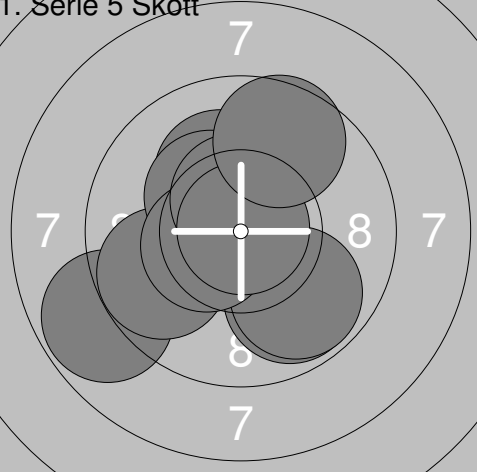
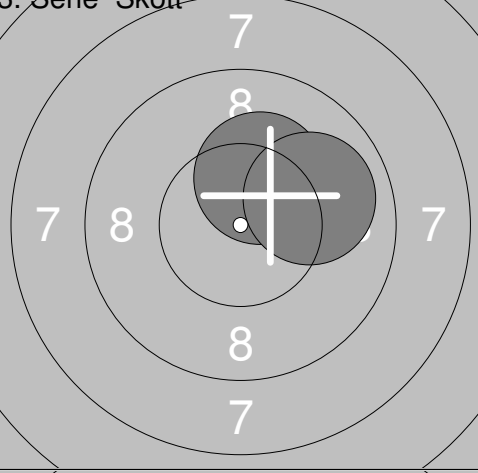
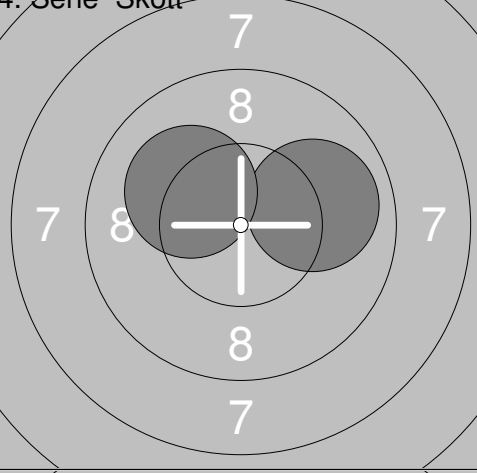
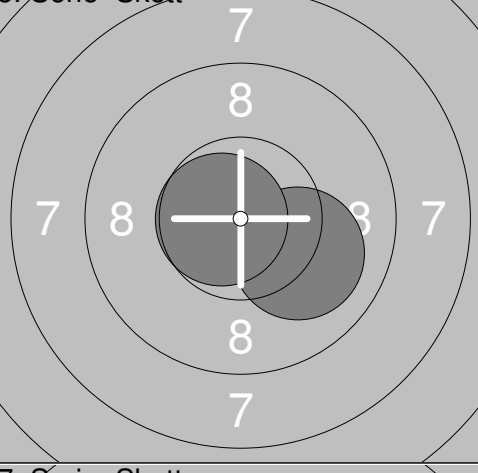
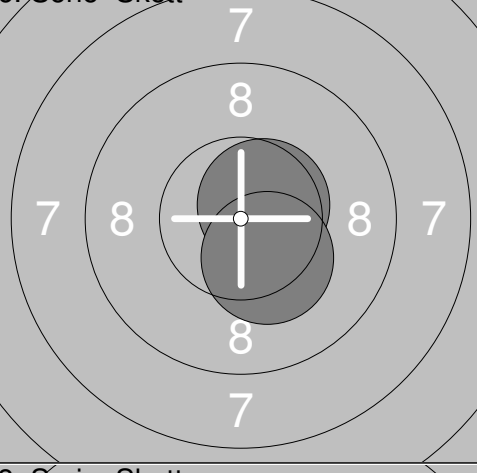

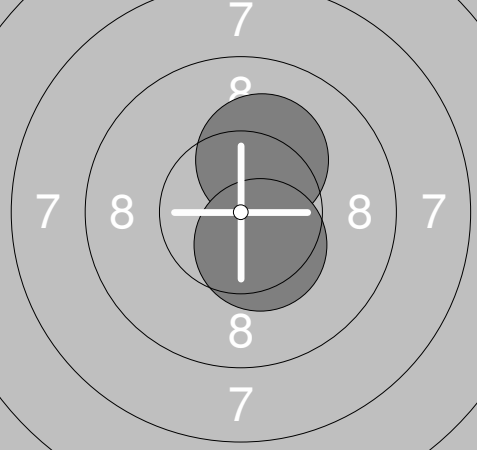

<p>Pröv</p> 	<table style="width:100%; border-collapse: collapse;"> <tr><td>1:</td><td>9.6</td><td>→</td></tr> <tr><td>2:</td><td>10.3x</td><td>↗</td></tr> <tr><td>3:</td><td>10.5x</td><td>↗</td></tr> <tr><td>4:</td><td>10.2x</td><td>↗</td></tr> <tr><td>5:</td><td>9.2</td><td>→</td></tr> <tr><td>6:</td><td>9.7</td><td>↗</td></tr> </table>	1:	9.6	→	2:	10.3x	↗	3:	10.5x	↗	4:	10.2x	↗	5:	9.2	→	6:	9.7	↗	<p>1. Serie 5 Skott</p>  <table style="width:100%; border-collapse: collapse;"> <tr><td>1:</td><td>10.3x</td><td>↗</td></tr> <tr><td>2:</td><td>9.6</td><td>↖</td></tr> <tr><td>3:</td><td>9.3</td><td>→</td></tr> <tr><td>4:</td><td>10.2x</td><td>↓</td></tr> <tr><td>5:</td><td>9.4</td><td>→</td></tr> <tr><td>6:</td><td>10.3x</td><td>↗</td></tr> <tr><td>7:</td><td>10.0</td><td>→</td></tr> <tr><td>8:</td><td>10.0</td><td>↖</td></tr> <tr><td>9:</td><td>10.7x</td><td>↑</td></tr> <tr><td>10:</td><td>10.1</td><td>↘</td></tr> </table>	1:	10.3x	↗	2:	9.6	↖	3:	9.3	→	4:	10.2x	↓	5:	9.4	→	6:	10.3x	↗	7:	10.0	→	8:	10.0	↖	9:	10.7x	↑	10:	10.1	↘
1:	9.6	→																																																
2:	10.3x	↗																																																
3:	10.5x	↗																																																
4:	10.2x	↗																																																
5:	9.2	→																																																
6:	9.7	↗																																																
1:	10.3x	↗																																																
2:	9.6	↖																																																
3:	9.3	→																																																
4:	10.2x	↓																																																
5:	9.4	→																																																
6:	10.3x	↗																																																
7:	10.0	→																																																
8:	10.0	↖																																																
9:	10.7x	↑																																																
10:	10.1	↘																																																
	<table style="width:100%; border-collapse: collapse;"> <tr><td style="border-top: 1px solid black;">Serie</td><td style="border-top: 1px solid black;">59.5</td></tr> <tr><td style="border-top: 1px solid black;">Total</td><td style="border-top: 1px solid black;">0.0</td></tr> </table>	Serie	59.5	Total	0.0	<table style="width:100%; border-collapse: collapse;"> <tr><td style="border-top: 1px solid black;">Serie</td><td style="border-top: 1px solid black;">99.9</td></tr> <tr><td style="border-top: 1px solid black;">Total</td><td style="border-top: 1px solid black;">99.9</td></tr> </table>	Serie	99.9	Total	99.9																																								
Serie	59.5																																																	
Total	0.0																																																	
Serie	99.9																																																	
Total	99.9																																																	
<p>3. Serie Skott</p> 	<table style="width:100%; border-collapse: collapse;"> <tr><td>1:</td><td>9.9</td><td>↙</td></tr> <tr><td>2:</td><td>9.7</td><td>↙</td></tr> </table>	1:	9.9	↙	2:	9.7	↙	<p>4. Serie Skott</p>  <table style="width:100%; border-collapse: collapse;"> <tr><td>1:</td><td>10.6x</td><td>↘</td></tr> <tr><td>2:</td><td>9.9</td><td>↖</td></tr> </table>	1:	10.6x	↘	2:	9.9	↖																																				
1:	9.9	↙																																																
2:	9.7	↙																																																
1:	10.6x	↘																																																
2:	9.9	↖																																																
	<table style="width:100%; border-collapse: collapse;"> <tr><td style="border-top: 1px solid black;">Serie</td><td style="border-top: 1px solid black;">19.6</td></tr> <tr><td style="border-top: 1px solid black;">Total</td><td style="border-top: 1px solid black;">119.5</td></tr> </table>	Serie	19.6	Total	119.5	<table style="width:100%; border-collapse: collapse;"> <tr><td style="border-top: 1px solid black;">Serie</td><td style="border-top: 1px solid black;">20.5</td></tr> <tr><td style="border-top: 1px solid black;">Total</td><td style="border-top: 1px solid black;">140.0</td></tr> </table>	Serie	20.5	Total	140.0																																								
Serie	19.6																																																	
Total	119.5																																																	
Serie	20.5																																																	
Total	140.0																																																	
<p>5. Serie Skott</p> 	<table style="width:100%; border-collapse: collapse;"> <tr><td>1:</td><td>9.9</td><td>→</td></tr> <tr><td>2:</td><td>10.6x</td><td>↗</td></tr> </table>	1:	9.9	→	2:	10.6x	↗	<p>6. Serie Skott</p>  <table style="width:100%; border-collapse: collapse;"> <tr><td>1:</td><td>10.1</td><td>↘</td></tr> <tr><td>2:</td><td>10.3x</td><td>↑</td></tr> </table>	1:	10.1	↘	2:	10.3x	↑																																				
1:	9.9	→																																																
2:	10.6x	↗																																																
1:	10.1	↘																																																
2:	10.3x	↑																																																
	<table style="width:100%; border-collapse: collapse;"> <tr><td style="border-top: 1px solid black;">Serie</td><td style="border-top: 1px solid black;">20.5</td></tr> <tr><td style="border-top: 1px solid black;">Total</td><td style="border-top: 1px solid black;">160.5</td></tr> </table>	Serie	20.5	Total	160.5	<table style="width:100%; border-collapse: collapse;"> <tr><td style="border-top: 1px solid black;">Serie</td><td style="border-top: 1px solid black;">20.4</td></tr> <tr><td style="border-top: 1px solid black;">Total</td><td style="border-top: 1px solid black;">180.9</td></tr> </table>	Serie	20.4	Total	180.9																																								
Serie	20.5																																																	
Total	160.5																																																	
Serie	20.4																																																	
Total	180.9																																																	
<p>7. Serie Skott</p> 	<table style="width:100%; border-collapse: collapse;"> <tr><td>1:</td><td>10.0</td><td>↖</td></tr> <tr><td>2:</td><td>10.8x</td><td>↗</td></tr> </table>	1:	10.0	↖	2:	10.8x	↗																																											
1:	10.0	↖																																																
2:	10.8x	↗																																																
	<table style="width:100%; border-collapse: collapse;"> <tr><td style="border-top: 1px solid black;">Serie</td><td style="border-top: 1px solid black;">20.8</td></tr> <tr><td style="border-top: 1px solid black;">Total</td><td style="border-top: 1px solid black;">201.7</td></tr> </table>	Serie	20.8	Total	201.7																																													
Serie	20.8																																																	
Total	201.7																																																	

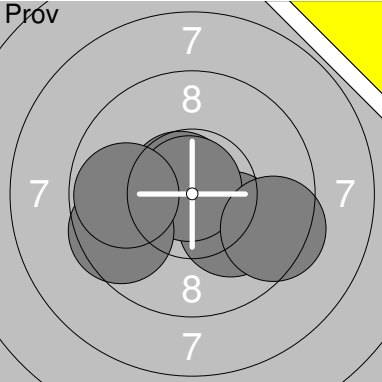
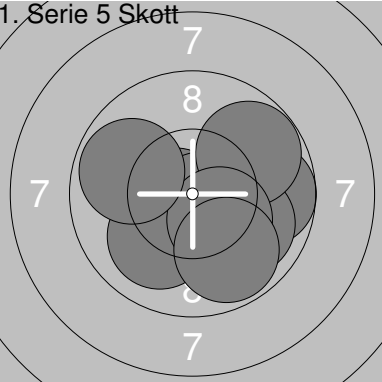
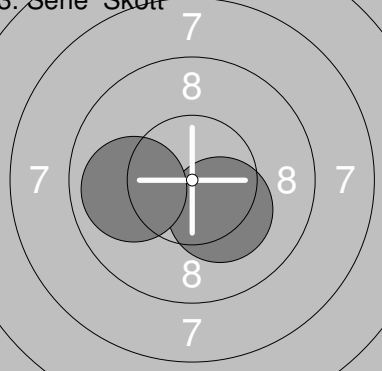
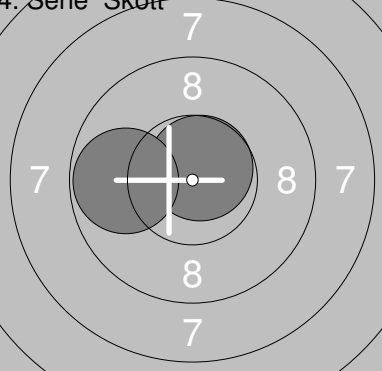
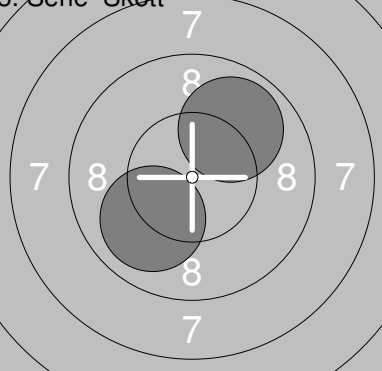

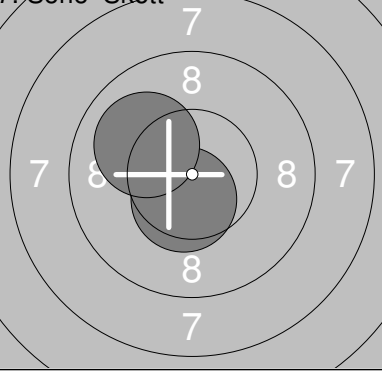
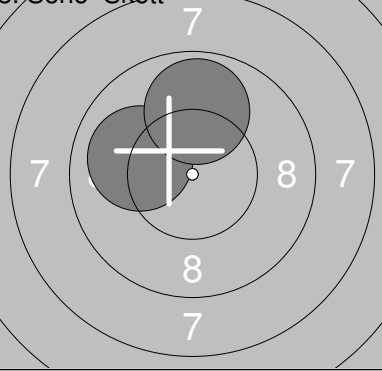
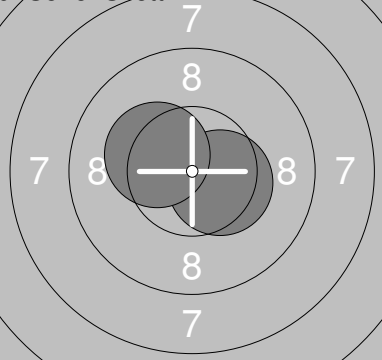
Skjuttlag 2	Tavla 14	Anna Mårtensson			
S		Kyrkås Skf			
05.10.2019		UME-Skottet 2019		Umeå skytteallians	
Pröv 		1: 10.0 ↓ 2: 10.3x ↓ 3: 10.6x ↑ 4: 10.5x ↗ 5: 10.7x ↗ 6: 10.1 ↗	1. Serie 5 Skott 	1: 10.4x ↖ 2: 10.3x ↓ 3: 10.1 ↗ 4: 10.8x ↗ 5: 10.0 → 6: 10.6x → 7: 9.8 ↑ 8: 10.6x ↓ 9: 10.5x → 10: 9.6 ↖	
		Serie 62.2	Serie 102.7		
		Total 0.0	Total 102.7		
3. Serie Skott 		1: 9.8 ↓ 2: 10.5x ↓	4. Serie Skott 	1: 10.2x ↗ 2: 9.9 →	
		Serie 20.3	Serie 20.1		
		Total 123.0	Total 143.1		
5. Serie Skott 		1: 10.7x ↑ 2: 9.4 ↙	6. Serie Skott 	1: 9.8 ↖ 2: 10.2x ↑	
		Serie 20.1	Serie 20.0		
		Total 163.2	Total 183.2		
7. Serie Skott 		1: 10.6x ↖ 2: 10.4x ←	8. Serie Skott 	1: 10.7x ↗ 2: 10.7x ↗	
		Serie 21.0	Serie 21.4		
		Total 204.2	Total 225.6		
9. Serie Skott 		1: 10.5x ↓ 2: 10.1 ↓			
		Serie 20.6			
		Total 246.2			

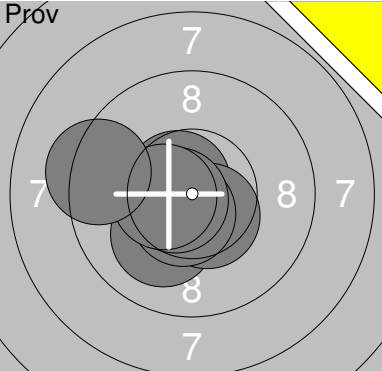
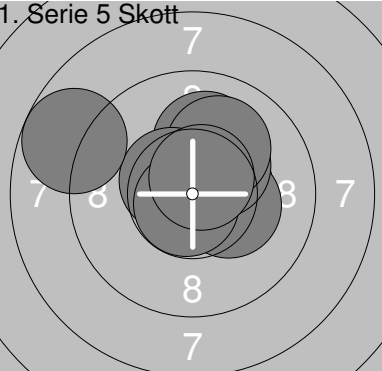
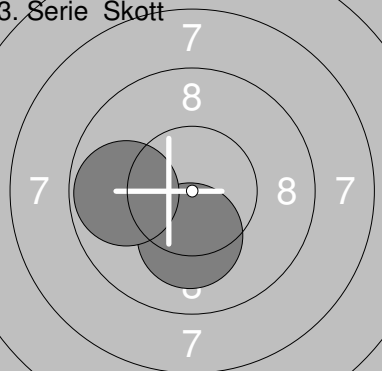

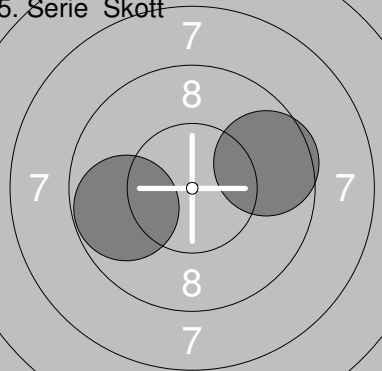
<p>Pröv</p> 	<p>1: 9.6 ↗ 2: 10.8x ↙ 3: 9.9 ↓ 4: 10.6x ↘ 5: 10.5x ↑ 6: 10.4x ↖</p>	<p>1. Serie 5 Skott</p> 	<p>1: 9.8 ↓ 2: 10.2x ↑ 3: 9.8 ↓ 4: 8.8 ↙ 5: 9.8 ↖ 6: 10.3x ↗ 7: 10.5x ↖ 8: 10.5x ↑ 9: 10.9x ↗ 10: 9.6 ↑</p>
Serie 61.8		Serie 100.2	
Total 0.0		Total 100.2	
<p>3. Serie Skott</p> 	<p>1: 10.3x ↑ 2: 10.0 →</p>	<p>4. Serie Skott</p> 	<p>1: 10.0 → 2: 10.1 ↖</p>
Serie 20.3		Serie 20.1	
Total 120.5		Total 140.6	
<p>5. Serie Skott</p> 	<p>1: 10.0 ↘ 2: 10.7x ←</p>	<p>6. Serie Skott</p> 	<p>1: 10.6x ↗ 2: 10.3x ↘</p>
Serie 20.7		Serie 20.9	
Total 161.3		Total 182.2	
<p>7. Serie Skott</p> 	<p>1: 10.2x ↙ 2: 10.2x ↓</p>	<p>8. Serie Skott</p> 	<p>1: 10.2x ↑ 2: 10.4x ↘</p>
Serie 20.4		Serie 20.6	
Total 202.6		Total 223.2	

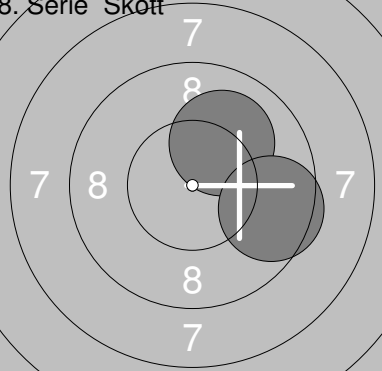
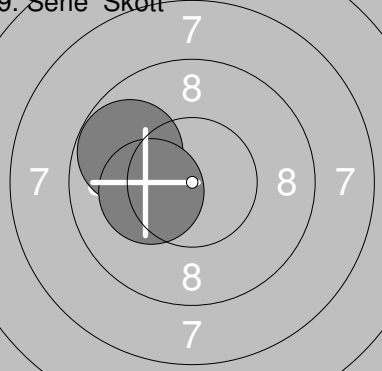
Skjutlag 2	Tavla 17	Mats Österlund			
S		Ramselefors Skf			
05.10.2019		UME-Skottet 2019		Umeå skytteallians	
Prov		1: 9.7 → 2: 6.7 ↘ 3: 6.9 ↗ 4: 10.2x ↘ 5: 10.1 ↘ 6: 8.8 ↘	1. Serie 5 Skott		1: 9.0 ↓ 2: 9.2 ↘ 3: 9.3 ← 4: 9.3 → 5: 8.4 ↘ 6: 10.1 ↘ 7: 10.0 ↘ 8: 10.1 ← 9: 7.0 ↘ 10: 7.2 ↘
		Serie 52.4 Total 0.0			Serie 89.6 Total 89.6
3. Serie Skott		1: 9.7 ↗ 2: 8.6 ↘	4. Serie Skott		1: 8.1 ↗ 2: 7.6 ↗
		Serie 18.3 Total 107.9			Serie 15.7 Total 123.6
5. Serie Skott		1: 10.2x ↗ 2: 9.2 ↘	6. Serie Skott		1: 8.6 ↗ 2: 8.7 ↗
		Serie 19.4 Total 143.0			Serie 17.3 Total 160.3
7. Serie Skott		1: 8.6 ↘ 2: 9.3 ↘	8. Serie Skott		1: 8.1 ↘ 2: 9.4 ↗
		Serie 17.9 Total 178.2			Serie 17.5 Total 195.7
9. Serie Skott		1: 10.3x ↘ 2: 8.6 ↗			
		Serie 18.9 Total 214.6			

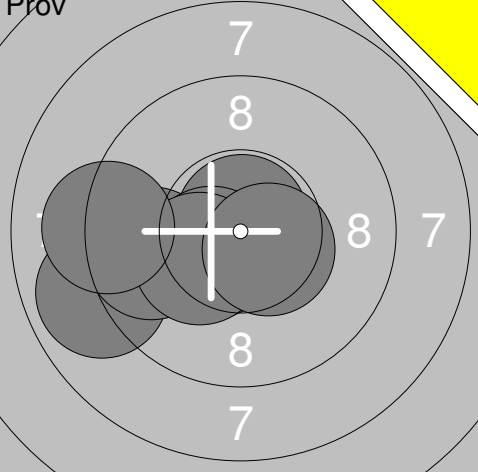
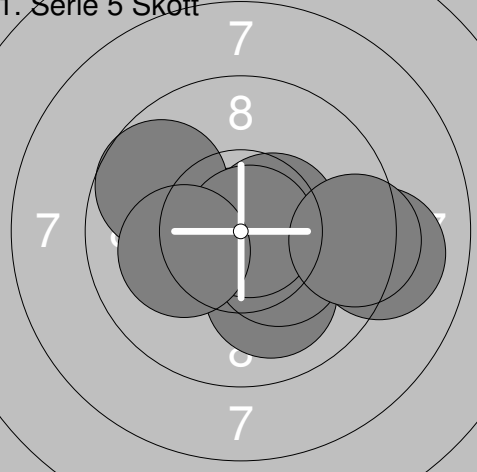
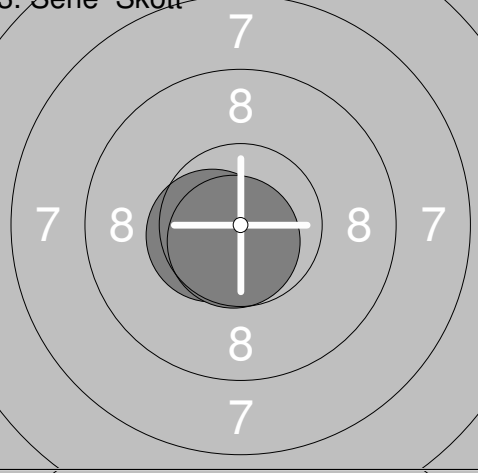
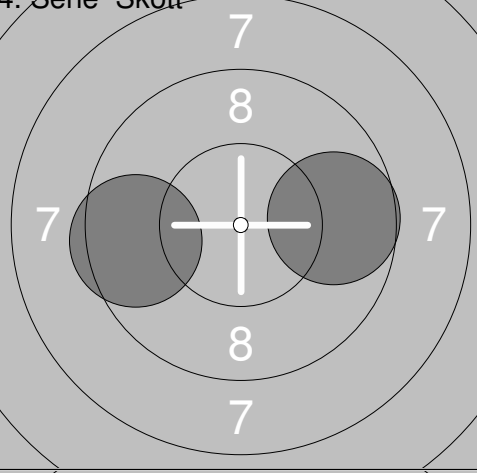
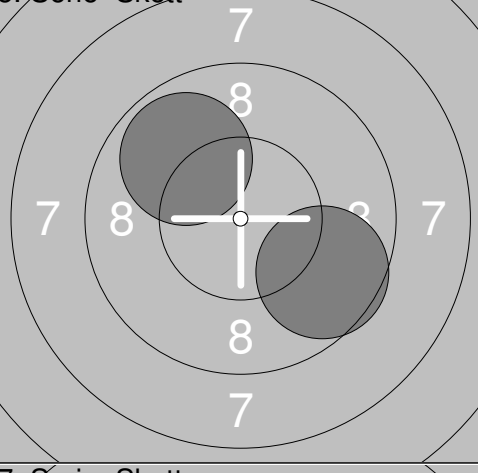
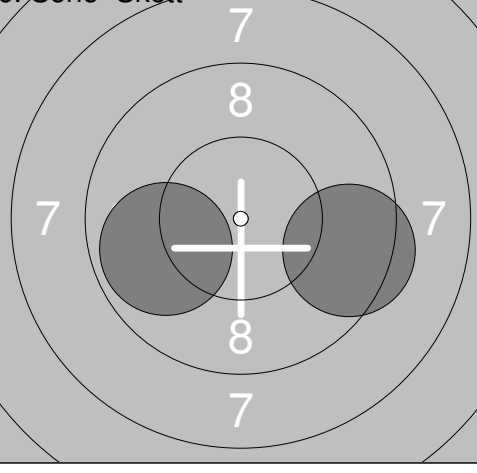
Skjuttlag 2	Tavla 19	Tomas Hed	
S		Forsa Skf	
05.10.2019		UME-Skottet 2019	Umeå skytteallians
Pröv 	1: 10.1 ↘ 2: 10.7x ↗ 3: 10.8x ↗ 4: 9.5 ↘ 5: 9.6 ↙ 6: 9.8 ↙	1. Serie 5 Skott 	1: 9.7 → 2: 10.6x ← 3: 10.7x ↘ 4: 10.2x ↘ 5: 10.0 ↘ 6: 10.0 ↘ 7: 9.8 ↗ 8: 10.3x ↘ 9: 9.9 ↗ 10: 9.8 ↘
	Serie 60.5		Serie 101.0
	Total 0.0		Total 101.0
3. Serie Skott 	1: 10.3x ↘ 2: 10.0 ←	4. Serie Skott 	1: 10.7x ↗ 2: 9.8 ←
	Serie 20.3		Serie 20.5
	Total 121.3		Total 141.8
5. Serie Skott 	1: 10.0 ↘ 2: 9.9 ↗	6. Serie Skott 	1: 10.9x ← 2: 10.5x ↘
	Serie 19.9		Serie 21.4
	Total 161.7		Total 183.1
7. Serie Skott 	1: 10.5x ↘ 2: 10.0 ↖	8. Serie Skott 	1: 10.0 ← 2: 9.9 ↑
	Serie 20.5		Serie 19.9
	Total 203.6		Total 223.5
9. Serie Skott 	1: 10.4x ↘ 2: 10.3x ↗		
	Serie 20.7		
	Total 244.2		

Skjuttlag 2	Tavla 21	Felicia Andersson			
S		Loos Skf			
05.10.2019		UME-Skottet 2019		Umeå skytteallians	
Pröv		1: 10.1 ↘ 2: 10.7x ↖ 3: 10.5x ↘ 4: 10.6x ↘ 5: 10.7x ← 6: 10.5x ← 7: 9.3 ←	1. Serie 5 Skott		1: 10.5x → 2: 10.3x → 3: 10.8x ↑ 4: 10.3x ↗ 5: 10.1 ↑ 6: 10.1 ↗ 7: 10.5x ↖ 8: 10.8x ↘ 9: 10.6x ↗ 10: 8.8 ↖
		Serie 72.4		Serie 102.8	
		Total 0.0		Total 102.8	
3. Serie Skott		1: 10.2x ↓ 2: 9.8 ←	4. Serie Skott		1: 10.9x ↑ 2: 10.3x ↖
		Serie 20.0		Serie 21.2	
		Total 122.8		Total 144.0	
5. Serie Skott		1: 9.8 ← 2: 9.6 →	6. Serie Skott		1: 10.6x ↖ 2: 10.5x ↗
		Serie 19.4		Serie 21.1	
		Total 163.4		Total 184.5	
7. Serie Skott		1: 10.1 → 2: 10.7x ↘	8. Serie Skott		1: 10.1 ↗ 2: 9.6 →
		Serie 20.8		Serie 19.7	
		Total 205.3		Total 225.0	
9. Serie Skott		1: 9.8 ↖ 2: 10.2x ←			
		Serie 20.0			
		Total 245.0			

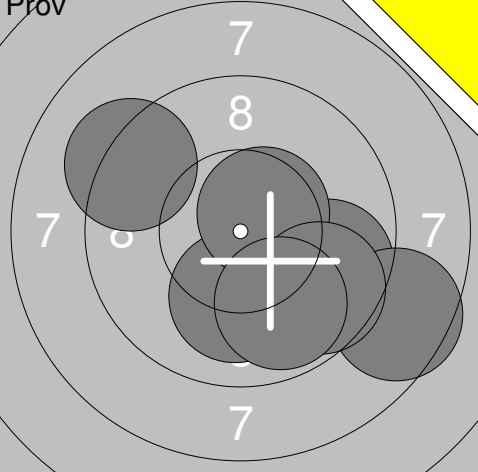
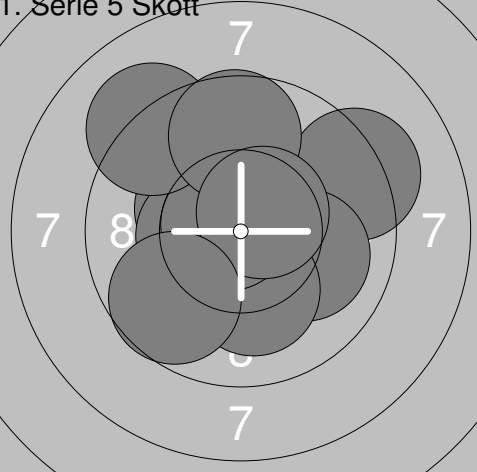
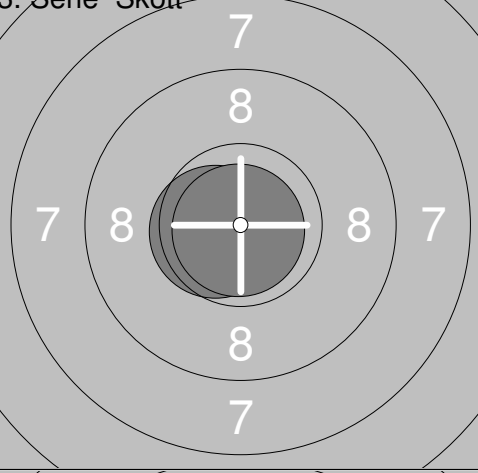
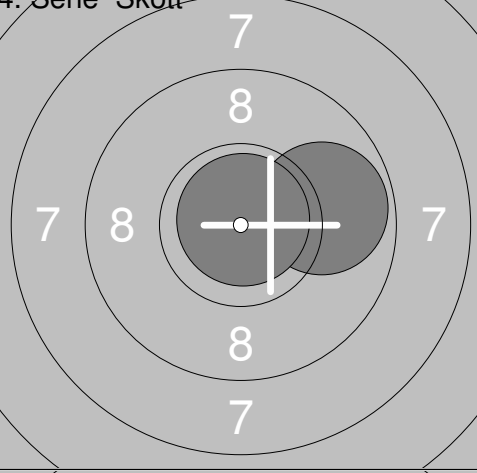
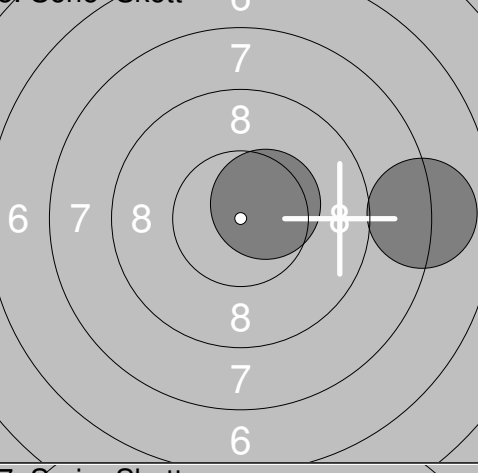
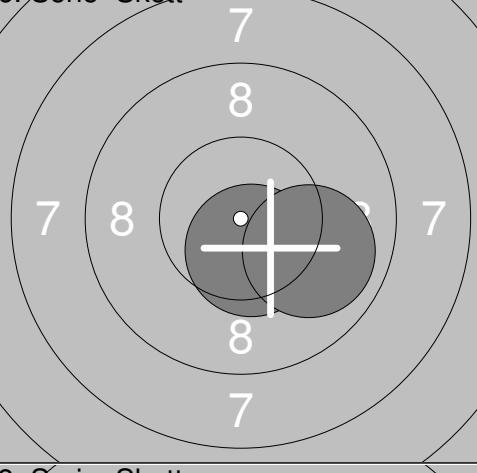
Pröv 	1: 8.9 ← 2: 9.7 ← 3: 10.8x ↑ 4: 10.5x ← 5: 10.3x ← 6: 9.2 ← 7: 10.5x ↘ <hr/> Serie 69.9 Total 0.0	1. Serie 5 Skott 	1: 10.6x → 2: 10.8x ← 3: 10.0 ↓ 4: 10.5x → 5: 9.7 ↗ 6: 10.3x ↓ 7: 10.8x → 8: 9.1 → 9: 10.1 ← 10: 9.4 → <hr/> Serie 101.3 Total 101.3
3. Serie Skott 	1: 10.5x ← 2: 10.7x ↓ <hr/> Serie 21.2 Total 122.5	4. Serie Skott 	1: 9.7 → 2: 9.5 ← <hr/> Serie 19.2 Total 141.7
5. Serie Skott 	1: 9.6 ↘ 2: 9.9 ↗ <hr/> Serie 19.5 Total 161.2	6. Serie Skott 	1: 9.9 ← 2: 9.4 → <hr/> Serie 19.3 Total 180.5
7. Serie Skott 	1: 10.4x ↓ 2: 9.7 → <hr/> Serie 20.1 Total 200.6		

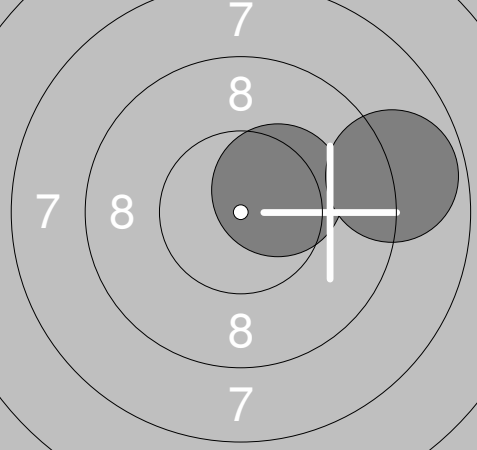
Pröv 	1: 9.7 → 2: 10.1 ↓ 3: 10.6x ↗ 4: 8.6 ↘ 5: 9.6 ↘ 6: 9.2 ↗ 7: 9.8 ↘	1. Serie 5 Skott 	1: 9.2 → 2: 10.3x ↖ 3: 10.4x ← 4: 10.0 → 5: 10.1 ↓ 6: 10.7x ↖ 7: 9.1 ↗ 8: 9.7 ↑ 9: 10.6x ↗ 10: 9.7 ↘
	Serie 67.6		Serie 99.8
	Total 0.0		Total 99.8
3. Serie Skott 	1: 10.6x ← 2: 10.9x ↘	4. Serie Skott 	1: 9.8 → 2: 10.9x ↑
	Serie 21.5		Serie 20.7
	Total 121.3		Total 142.0
5. Serie Skott 	1: 8.0 → 2: 10.5x ↗	6. Serie Skott 	1: 10.5x ↓ 2: 9.9 →
	Serie 18.5		Serie 20.4
	Total 160.5		Total 180.9
7. Serie Skott 	1: 10.5x ↓ 2: 10.4x ↗	8. Serie Skott 	1: 10.4x ↗ 2: 8.8 →
	Serie 20.9		Serie 19.2
	Total 201.8		Total 221.0

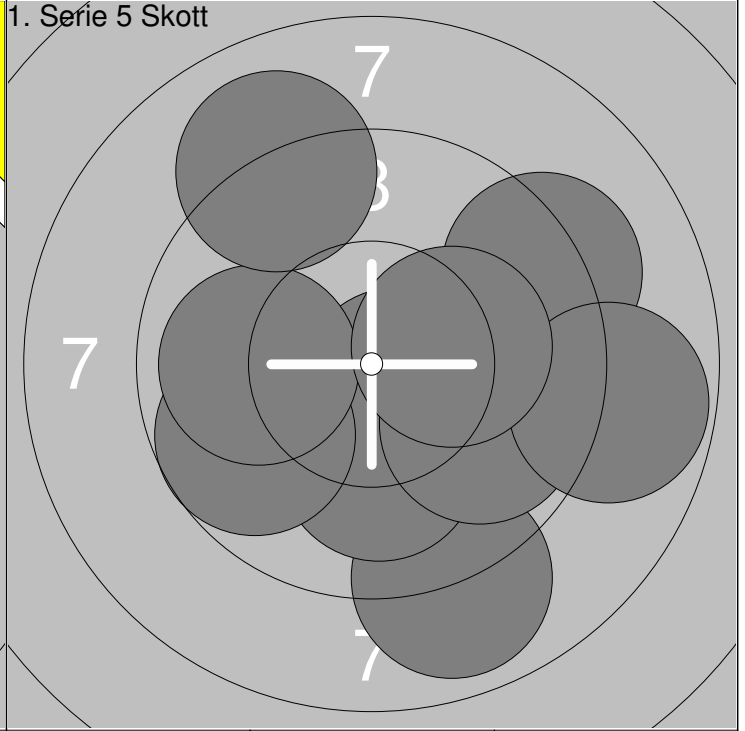
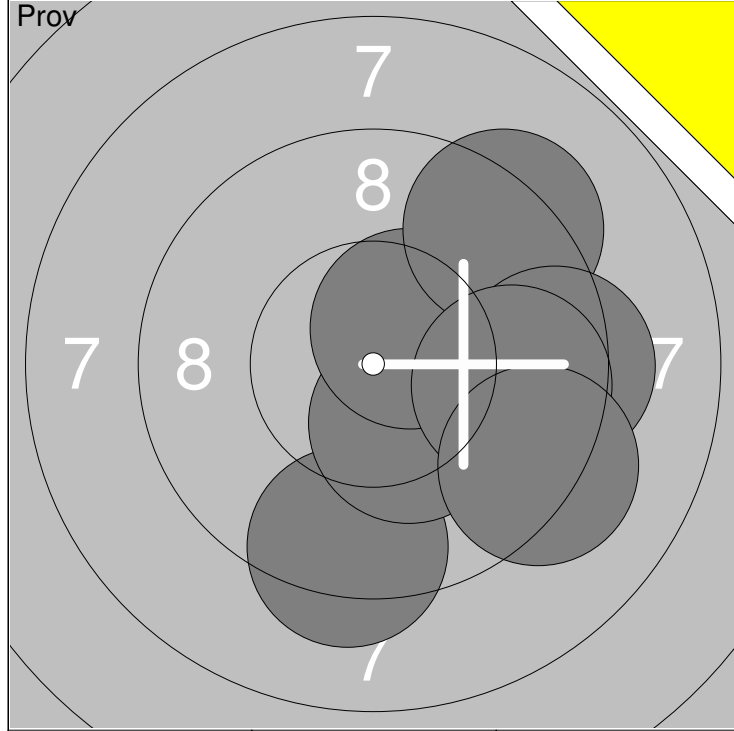

1: 9.3 ↓	6: 9.7 →	Serie	67.6
2: 10.3x ↓	7: 9.2 ↘		
3: 10.5x ↗		Total	0.0
4: 9.3 ↗			
5: 9.3 →			

1: 8.9 ↓	6: 10.0 ←	Serie	96.3
2: 10.6x ↘	7: 9.8 ↘		
3: 10.1 ↓	8: 8.8 →	Total	96.3
4: 9.2 ↗	9: 9.0 ↗		
5: 9.7 ↙	10: 10.2x →		

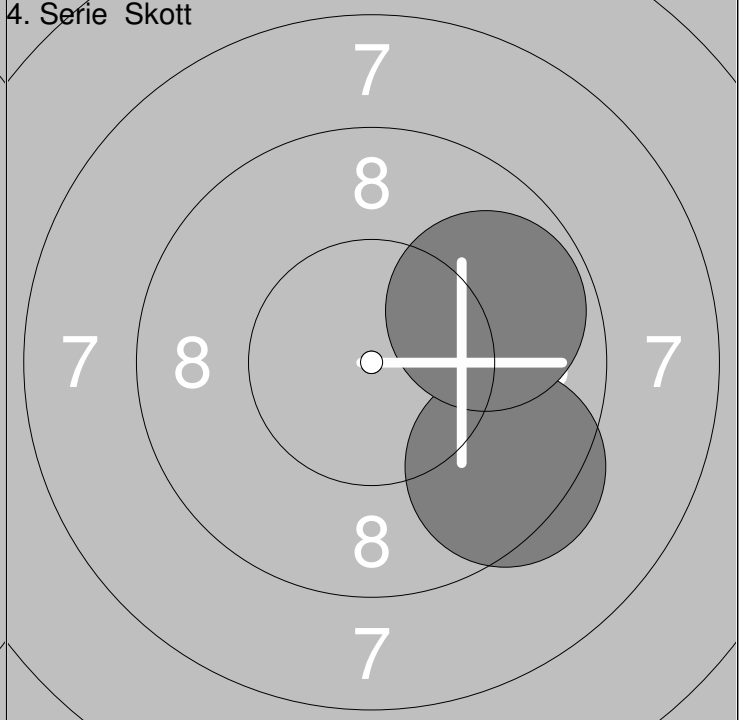
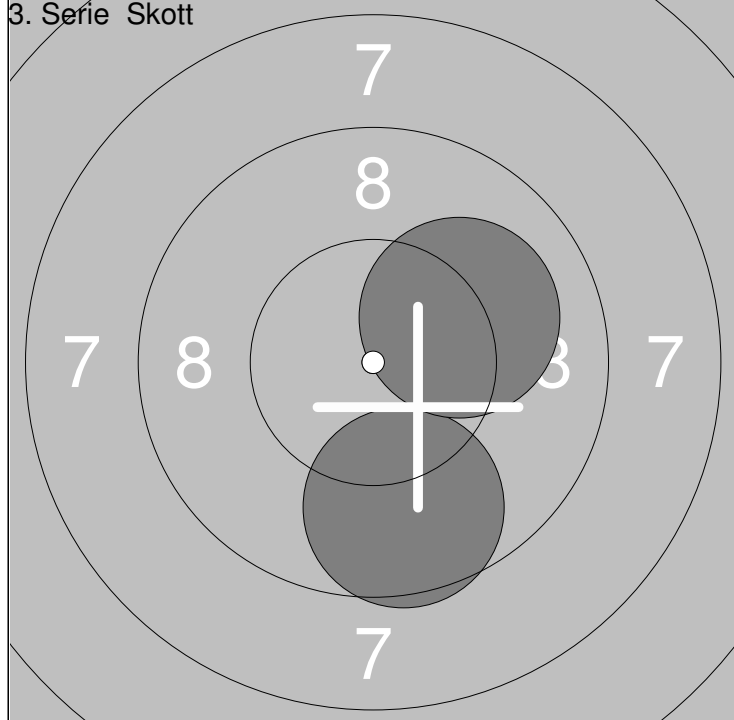

1: 9.6 ↓	Serie	19.7
2: 10.1 ↗		
	Total	116.0

1: 9.4 ↘	Serie	19.2
2: 9.8 ↗		
	Total	135.2

	1: 10.4x ↘ 2: 10.0 ↑ 3: 9.8 ↘ 4: 10.1 ↓ 5: 10.3x ↗ 6: 9.8 ← 7: 10.5x ↓ 8: 9.8 ←		1: 9.6 ↗ 2: 9.4 ↑ 3: 10.0 ↓ 4: 9.7 ↖ 5: 10.4x ↓ 6: 10.2x ← 7: 10.1 ↖ 8: 9.0 ← 9: 10.7x ↗ 10: 9.7 →
	Serie 80.7 Total 0.0		Serie 98.8 Total 98.8

	1: 10.1 → 2: 10.4x ↘		1: 8.8 → 2: 9.8 →
	Serie 20.5 Total 119.3		Serie 18.6 Total 137.9

	1: 10.0 → 2: 10.2x →		1: 10.5x ↓ 2: 10.5x ↘
	Serie 20.2 Total 158.1		Serie 21.0 Total 179.1

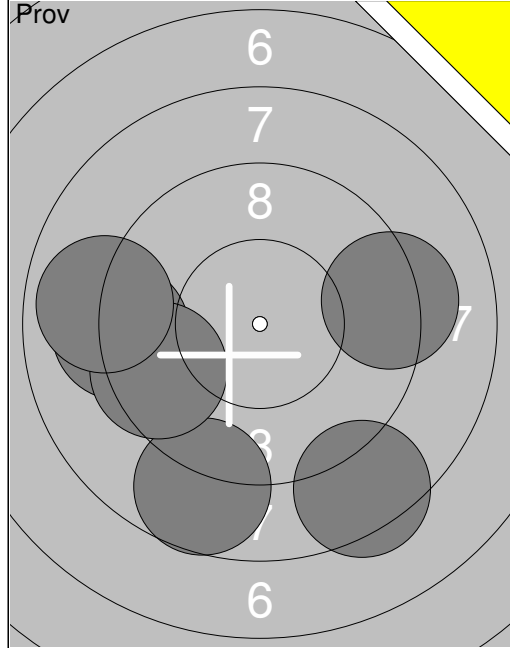

1:	8.4	↘
2:	9.2	→
3:	8.7	↘
4:	9.1	←
5:	9.5	←
6:	8.9	←
Serie 53.8		
Total 0.0		

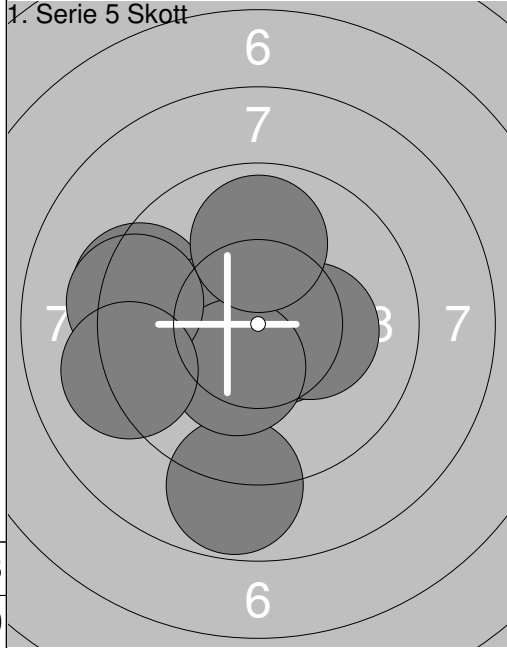

1:	10.7x	↘
2:	9.5	←
3:	9.4	←
4:	10.5x	←
5:	10.3x	→
6:	8.8	↘
7:	10.3x	↘
8:	9.3	←
9:	9.2	←
10:	9.9	↑
Serie 97.9		
Total 97.9		

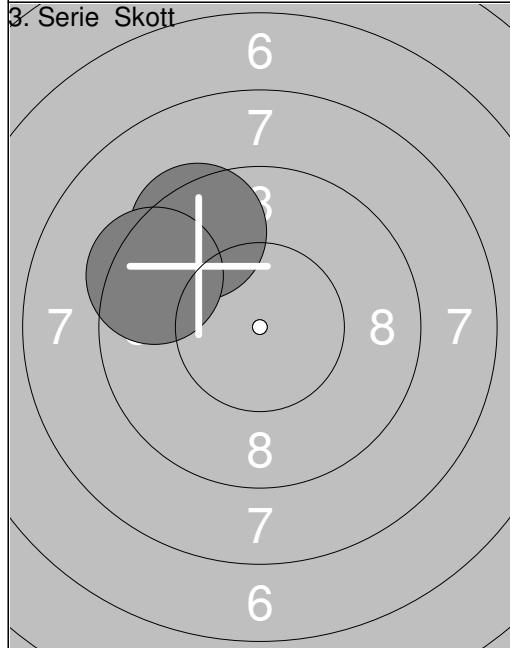



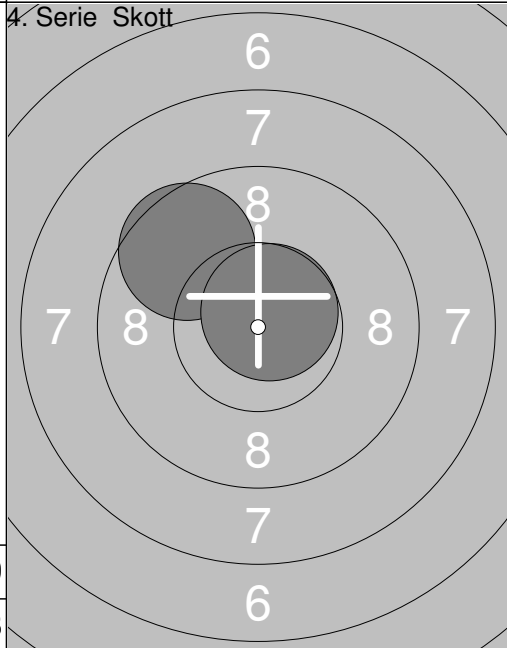

1:	9.5	↖
2:	9.4	↖
Serie 18.9		
Total 116.8		

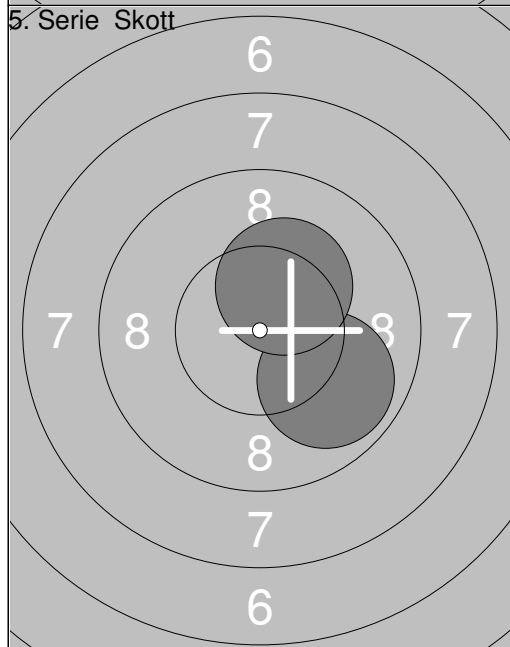

1:	9.6	↖
2:	10.7x	↗
Serie 20.3		
Total 137.1		

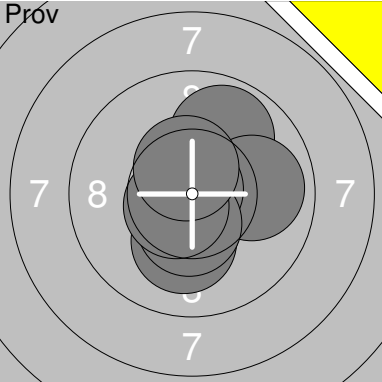
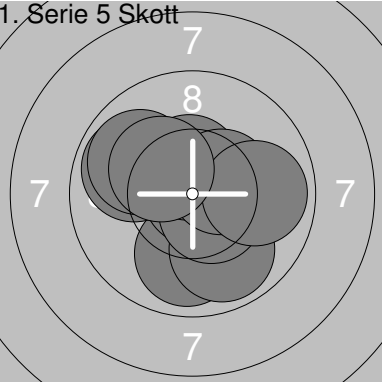
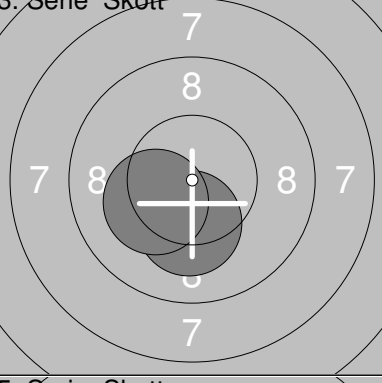
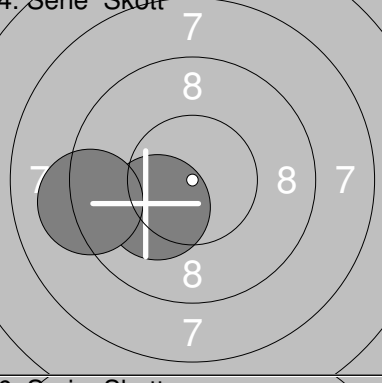

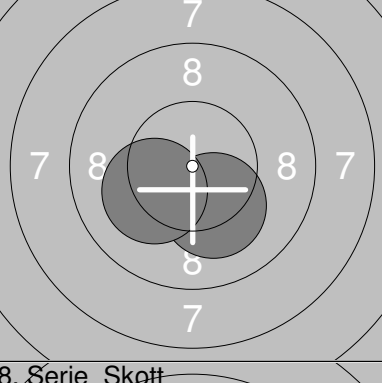
1:	9.9	↘
2:	10.3x	↗
Serie 20.2		
Total 157.3		

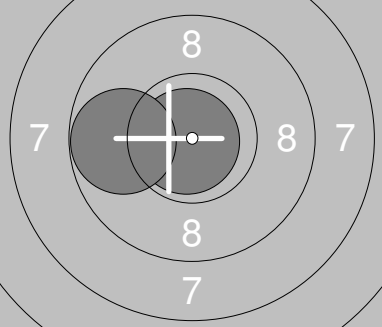
Skjuttag 2	Tavla 28	Nicolle Nygren			
S		Umeå Skf			
05.10.2019		UME-Skottet 2019		Umeå skytteallians	
Pröv		1: 9.9 ↗ 2: 10.4x ↓ 3: 10.1 ↓ 4: 9.9 → 5: 10.9x ↑ 6: 10.4x ↓ 7: 10.6x ↙ 8: 10.5x ↑	1. Serie 5 Skott		1: 9.9 ↓ 2: 9.9 ↓ 3: 10.9x → 4: 10.5x ↓ 5: 10.5x ↑ 6: 10.4x → 7: 9.9 → 8: 9.9 ↖ 9: 9.9 ↖ 10: 10.3x ↖
		Serie	82.7		
		Total	0.0		
		Serie		Serie	102.1
		Total		Total	102.1
3. Serie Skott		1: 10.2x ↓ 2: 10.2x ↙	4. Serie Skott		1: 10.2x ↙ 2: 9.2 ↙
		Serie	20.4		
		Total	122.5		
		Serie		Serie	19.4
		Total		Total	141.9
5. Serie Skott		1: 10.8x ↗ 2: 9.9 ↗	6. Serie Skott		1: 10.2x ↓ 2: 10.2x ↙
		Serie	20.7		
		Total	162.6		
		Serie		Serie	20.4
		Total		Total	183.0
7. Serie Skott		1: 10.7x ↘ 2: 10.6x ↓	8. Serie Skott		1: 10.6x ↗ 2: 10.7x ↙
		Serie	21.3		
		Total	204.3		
		Serie		Serie	21.3
		Total		Total	225.6
9. Serie Skott		1: 10.8x ↙ 2: 9.8 ↙			
		Serie	20.6		
		Total	246.2		

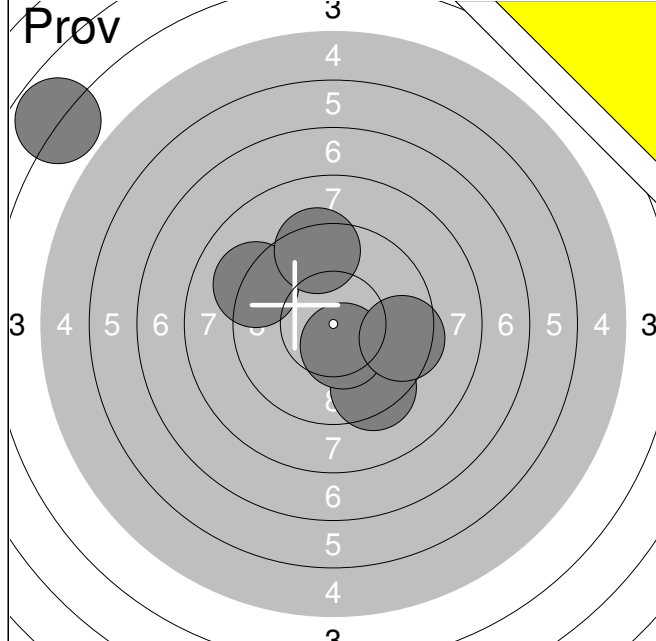

1:	9.4	↘
2:	9.1	↗
3:	9.4	↗
4:	3.8	↗
5:	10.4x	↘
6:	9.5	→
Serie	51.6	
Total	0.0	

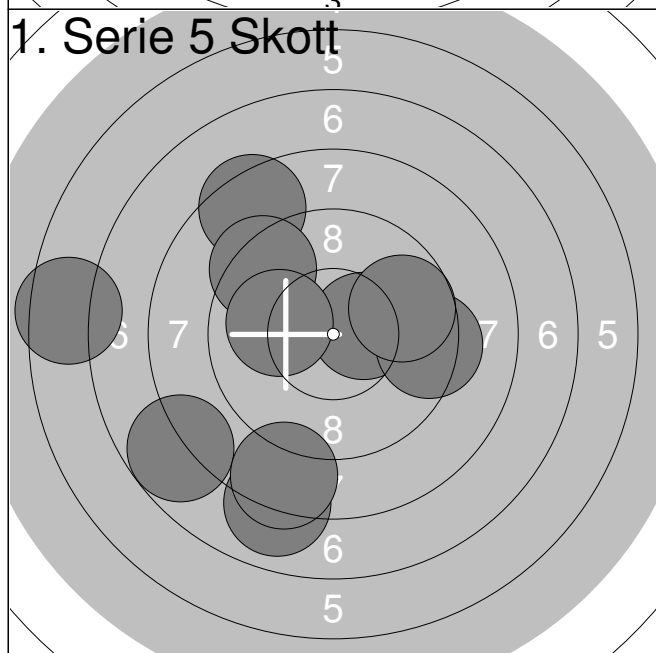

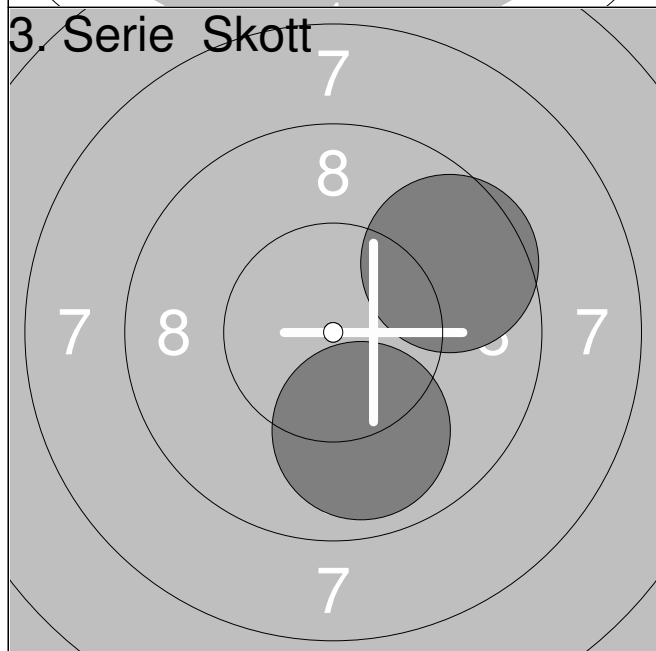

1:	7.8	↙
2:	10.4x	→
3:	8.4	↗
4:	6.5	↖
5:	9.4	↗
6:	8.0	↘
7:	10.0	↖
8:	9.3	→
9:	9.7	↗
10:	8.4	↘
Serie	87.9	
Total	87.9	

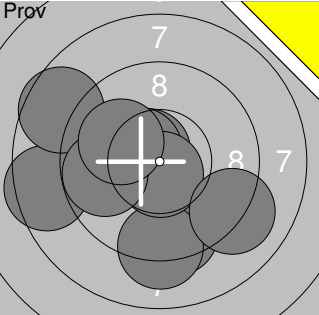
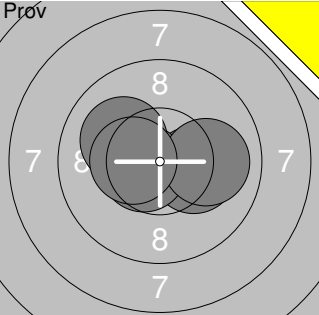
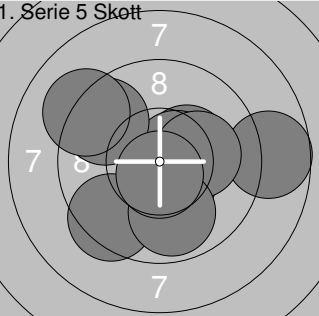
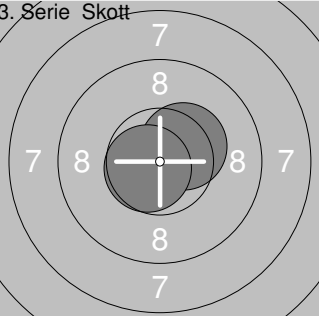
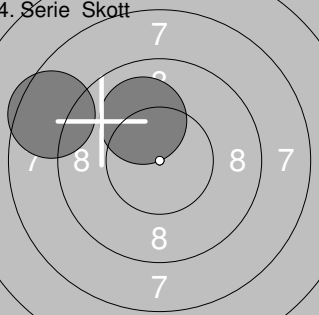
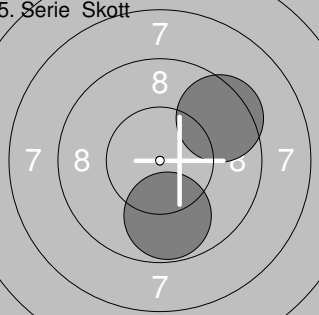
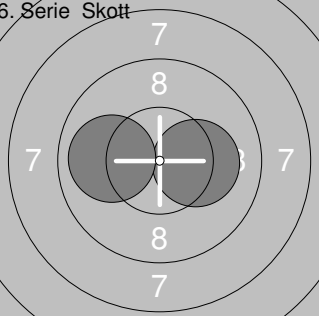
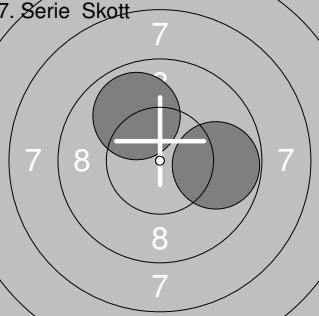
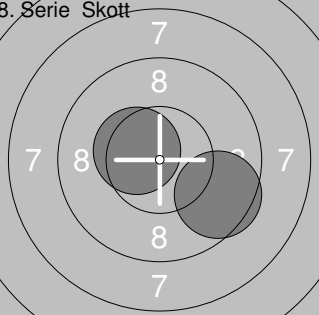
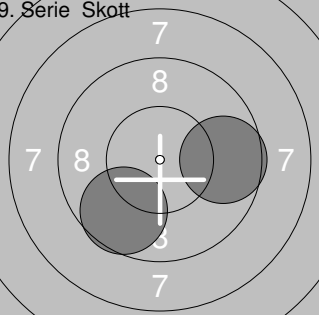
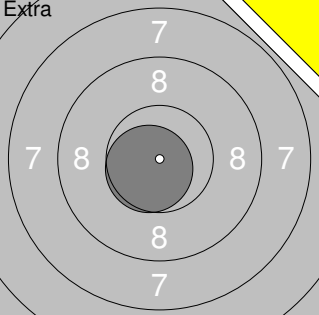

1:	9.6	↗
2:	9.9	↘
Serie	19.5	
Total	107.4	

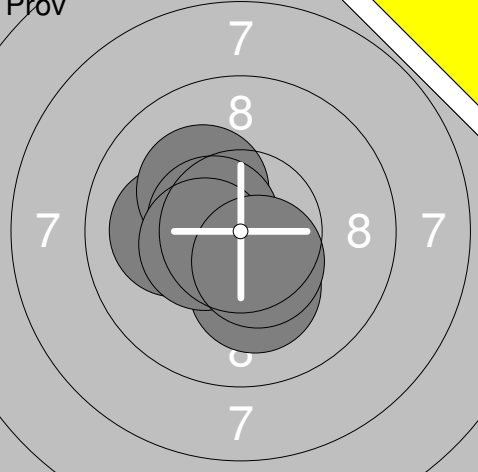
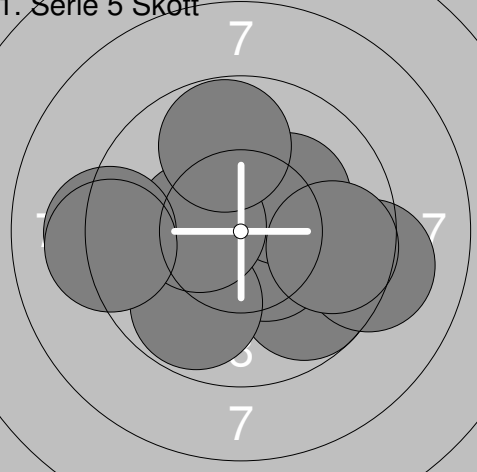
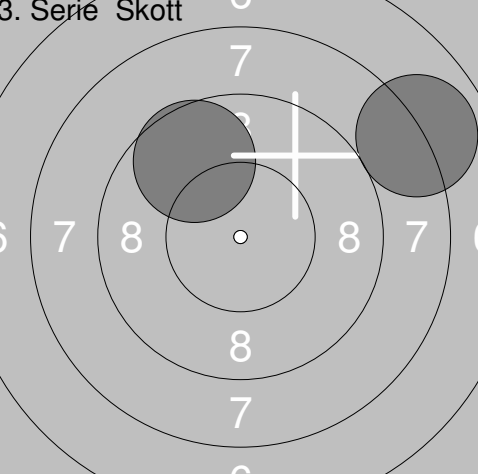
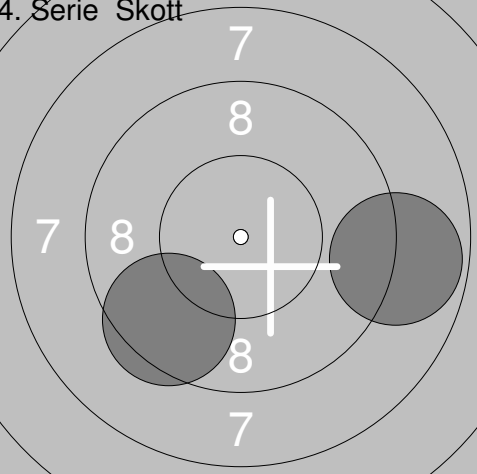
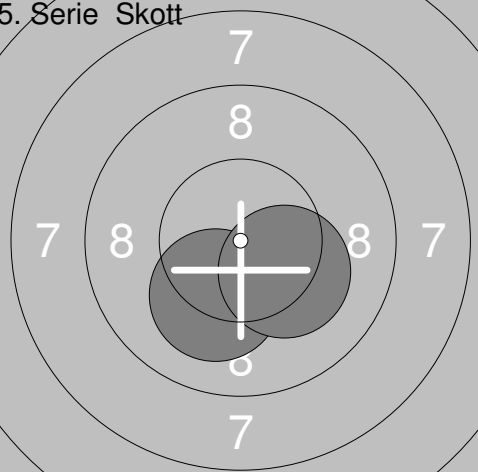
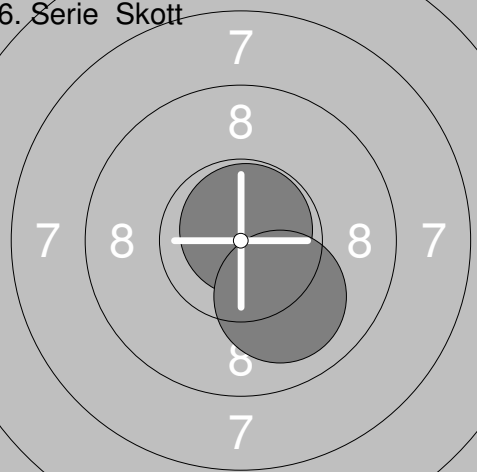
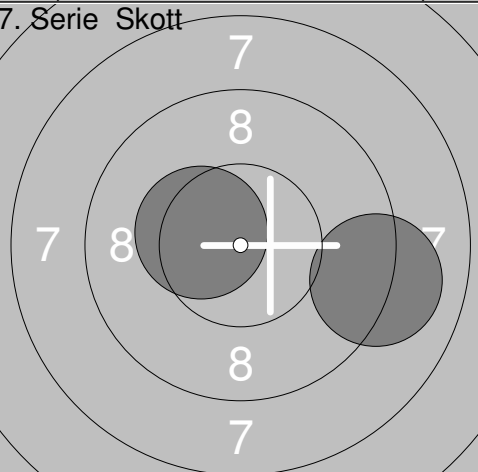
Skjutlag 2	Tavla 31	Vincent Stridsson			
S		Gällivare Skf			
05.10.2019		UME-Skottet 2019		Umeå skytteallians	
Pröv		1: 9.4 ↓ 2: 10.6x ↗ 3: 8.5 ← 4: 8.6 ↗ 5: 10.5x ↗ 6: 9.2 ↓ 7: 10.7x ↓ 8: 9.1 ↓ 9: 9.8 ← 10: 10.0 ↗	Pröv		11: 10.2x → 12: 10.6x ← 13: 10.0 → 14: 10.1 ↗ 15: 10.4x ←
		Serie 96.4 Total 0.0			Serie 51.3 Total 0.0
1. Serie 5 Skott		1: 9.4 ↘ 2: 10.3x ↗ 3: 8.7 → 4: 10.6x ↗ 5: 10.5x ↗ 6: 10.2x → 7: 9.9 ↓ 8: 9.6 ↗ 9: 9.1 ↗ 10: 10.7x ↓	3. Serie Skott		1: 10.4x ↗ 2: 10.7x ←
		Serie 99.0 Total 99.0			Serie 21.1 Total 120.1
4. Serie Skott		1: 8.5 ↗ 2: 10.1 ↗	5. Serie Skott		1: 9.8 ↓ 2: 9.4 ↗
		Serie 18.6 Total 138.7			Serie 19.2 Total 157.9
6. Serie Skott		1: 10.2x → 2: 10.0 ←	7. Serie Skott		1: 9.8 → 2: 9.9 ↗
		Serie 20.2 Total 178.1			Serie 19.7 Total 197.8
8. Serie Skott		1: 9.6 ↗ 2: 10.5x ↗	9. Serie Skott		1: 9.7 ↘ 2: 9.6 →
		Serie 20.1 Total 217.9			Serie 19.3 Total 237.2
Extra		1: 10.6x ↗			
		Serie 10.6 Total 237.2			

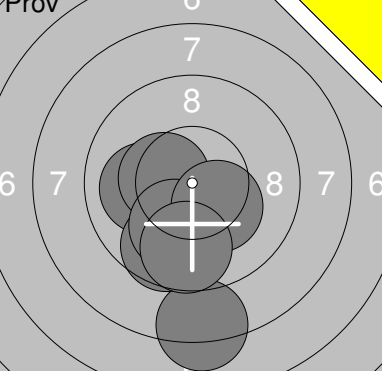
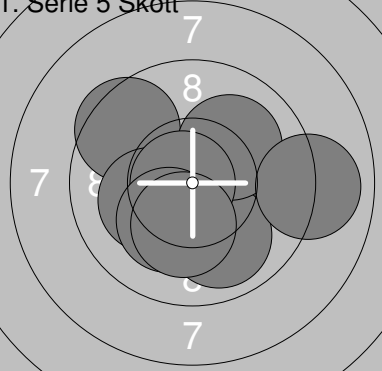
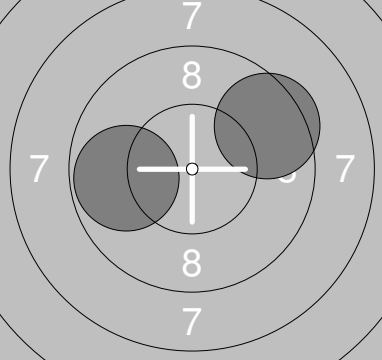
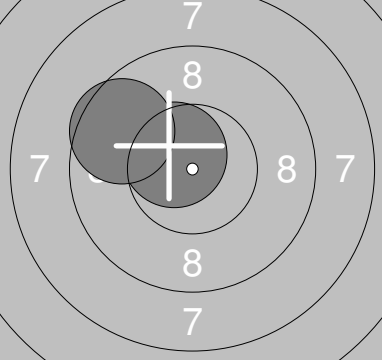
<p>Pröv</p> 	<p>1: 10.1 ← 2: 10.2x ↓ 3: 10.2x ↗ 4: 10.6x ↖ 5: 10.4x ← 6: 10.5x ↓</p>	<p>1. Serie 5 Skott</p> 	<p>1: 9.7 ↘ 2: 9.2 → 3: 10.5x ↓ 4: 9.8 ↓ 5: 10.2x ↗ 6: 10.4x ← 7: 9.2 ← 8: 9.7 → 9: 9.8 ↑ 10: 9.2 ←</p>
Serie 62.0 Total 0.0		Serie 97.7 Total 97.7	
<p>3. Serie Skott</p> 	<p>1: 8.0 ↗ 2: 9.6 ↖</p>	<p>4. Serie Skott</p> 	<p>1: 8.8 → 2: 9.5 ↘</p>
Serie 17.6 Total 115.3		Serie 18.3 Total 133.6	
<p>5. Serie Skott</p> 	<p>1: 10.1 ↓ 2: 10.2x ↘</p>	<p>6. Serie Skott</p> 	<p>1: 10.8x ↗ 2: 10.0 ↓</p>
Serie 20.3 Total 153.9		Serie 20.8 Total 174.7	
<p>7. Serie Skott</p> 	<p>1: 10.4x ← 2: 9.1 →</p>		
Serie 19.5 Total 194.2			

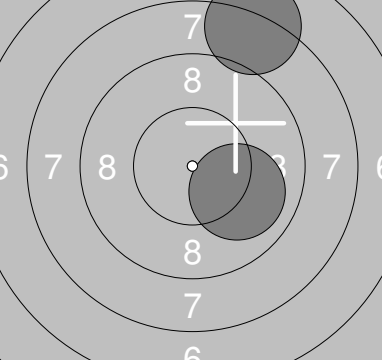
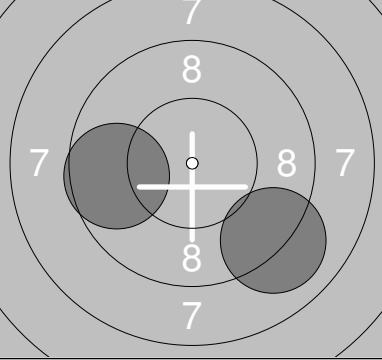
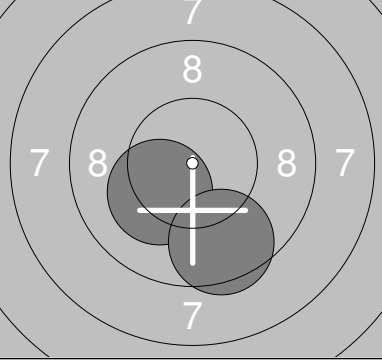
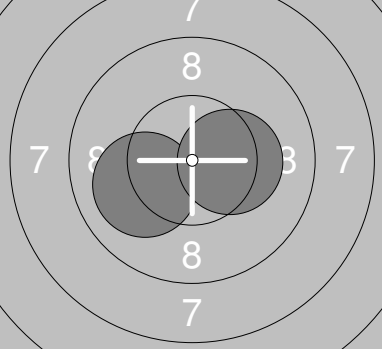
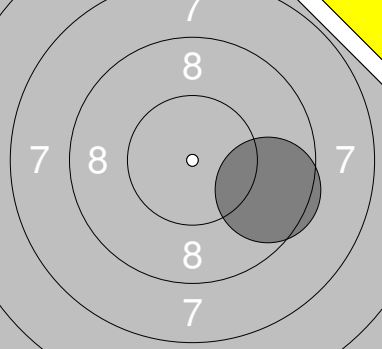
Prov 	1: 10.2x ↓ 2: 10.0 ← 3: 8.2 ↓ 4: 10.4x ← 5: 9.6 ↓ 6: 10.1 ↓ 7: 10.3x ↘ 8: 9.7 ↓ <hr/> Serie 78.5 Total 0.0	1. Serie 5 Skott 	1: 9.5 ↖ 2: 10.3x ↓ 3: 10.2x ← 4: 10.4x → 5: 10.0 ↓ 6: 10.1 ↗ 7: 10.8x ← 8: 10.2x ↓ 9: 9.0 → 10: 10.2x ↓ <hr/> Serie 100.7 Total 100.7
3. Serie Skott 	1: 9.8 ← 2: 9.5 ↗ <hr/> Serie 19.3 Total 120.0	4. Serie Skott 	1: 10.5x ↖ 2: 9.6 ↖ <hr/> Serie 20.1 Total 140.1
5. Serie Skott 	1: 9.6 → 2: 10.7x ← <hr/> Serie 20.3 Total 160.4	6. Serie Skott 	1: 10.0 → 2: 8.1 ↗ <hr/> Serie 18.1 Total 178.5
7. Serie Skott 	1: 9.6 ← 2: 9.0 ↘ <hr/> Serie 18.6 Total 197.1	8. Serie Skott 	1: 10.2x ↖ 2: 9.5 ↓ <hr/> Serie 19.7 Total 216.8
9. Serie Skott 	1: 10.1 ← 2: 10.3x → <hr/> Serie 20.4 Total 237.2	Extra 	1: 9.6 → <hr/> Serie 9.6 Total 237.2

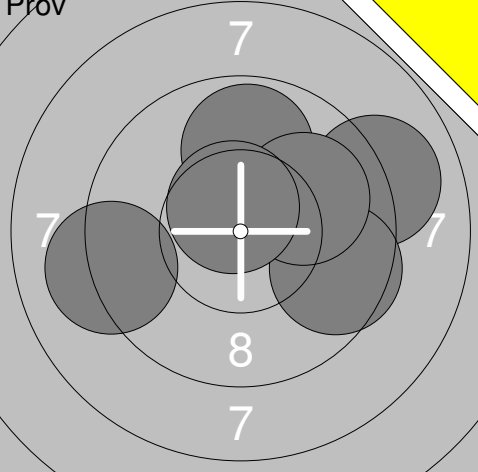
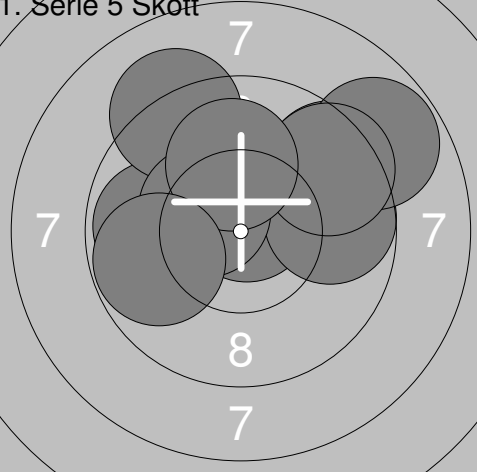
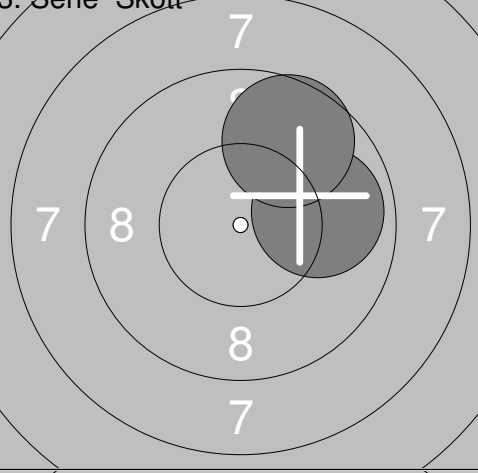
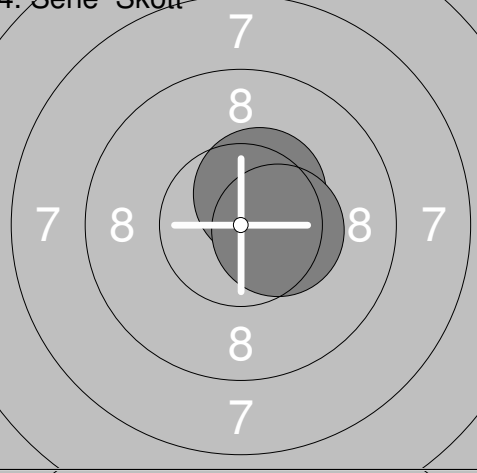
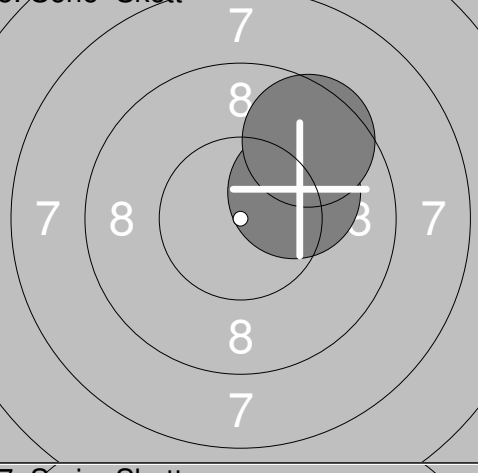
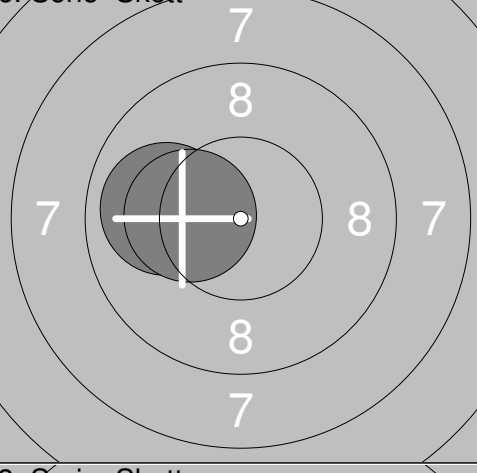
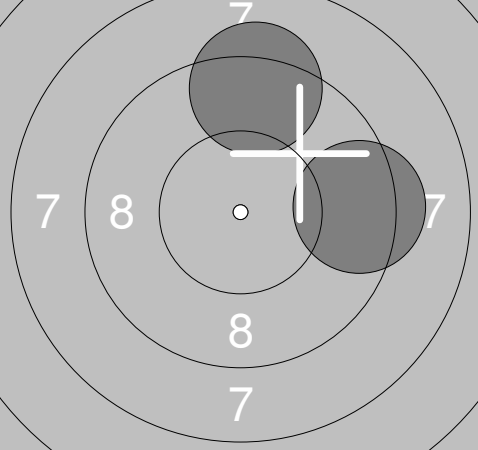
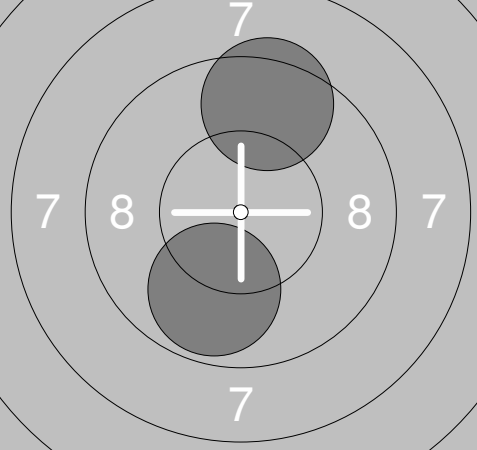
<p>Pröv</p> 	<table border="1" style="width:100%; border-collapse: collapse;"> <tr><td>1:</td><td>9.0</td><td>→</td></tr> <tr><td>2:</td><td>9.6</td><td>→</td></tr> <tr><td>3:</td><td>9.9</td><td>↑</td></tr> <tr><td>4:</td><td>10.0</td><td>→</td></tr> <tr><td>5:</td><td>10.6x</td><td>↑</td></tr> <tr><td>6:</td><td>9.1</td><td>←</td></tr> </table> <table border="1" style="width:100%; border-collapse: collapse; margin-top: 5px;"> <tr><td>Serie</td><td>58.2</td></tr> <tr><td>Total</td><td>0.0</td></tr> </table>	1:	9.0	→	2:	9.6	→	3:	9.9	↑	4:	10.0	→	5:	10.6x	↑	6:	9.1	←	Serie	58.2	Total	0.0	<p>1. Serie 5 Skott</p>  <table border="1" style="width:100%; border-collapse: collapse;"> <tr><td>1:</td><td>9.5</td><td>↗</td></tr> <tr><td>2:</td><td>10.7x</td><td>↑</td></tr> <tr><td>3:</td><td>9.8</td><td>←</td></tr> <tr><td>4:</td><td>9.7</td><td>→</td></tr> <tr><td>5:</td><td>9.2</td><td>↖</td></tr> <tr><td>6:</td><td>8.8</td><td>↗</td></tr> <tr><td>7:</td><td>9.5</td><td>↗</td></tr> <tr><td>8:</td><td>10.4x</td><td>↖</td></tr> <tr><td>9:</td><td>10.0</td><td>↑</td></tr> <tr><td>10:</td><td>9.8</td><td>←</td></tr> </table> <table border="1" style="width:100%; border-collapse: collapse; margin-top: 5px;"> <tr><td>Serie</td><td>97.4</td></tr> <tr><td>Total</td><td>97.4</td></tr> </table>	1:	9.5	↗	2:	10.7x	↑	3:	9.8	←	4:	9.7	→	5:	9.2	↖	6:	8.8	↗	7:	9.5	↗	8:	10.4x	↖	9:	10.0	↑	10:	9.8	←	Serie	97.4	Total	97.4
1:	9.0	→																																																								
2:	9.6	→																																																								
3:	9.9	↑																																																								
4:	10.0	→																																																								
5:	10.6x	↑																																																								
6:	9.1	←																																																								
Serie	58.2																																																									
Total	0.0																																																									
1:	9.5	↗																																																								
2:	10.7x	↑																																																								
3:	9.8	←																																																								
4:	9.7	→																																																								
5:	9.2	↖																																																								
6:	8.8	↗																																																								
7:	9.5	↗																																																								
8:	10.4x	↖																																																								
9:	10.0	↑																																																								
10:	9.8	←																																																								
Serie	97.4																																																									
Total	97.4																																																									
<p>3. Serie Skott</p> 	<table border="1" style="width:100%; border-collapse: collapse;"> <tr><td>1:</td><td>9.9</td><td>→</td></tr> <tr><td>2:</td><td>9.6</td><td>↗</td></tr> </table> <table border="1" style="width:100%; border-collapse: collapse; margin-top: 5px;"> <tr><td>Serie</td><td>19.5</td></tr> <tr><td>Total</td><td>116.9</td></tr> </table>	1:	9.9	→	2:	9.6	↗	Serie	19.5	Total	116.9	<p>4. Serie Skott</p>  <table border="1" style="width:100%; border-collapse: collapse;"> <tr><td>1:</td><td>10.5x</td><td>↗</td></tr> <tr><td>2:</td><td>10.4x</td><td>→</td></tr> </table> <table border="1" style="width:100%; border-collapse: collapse; margin-top: 5px;"> <tr><td>Serie</td><td>20.9</td></tr> <tr><td>Total</td><td>137.8</td></tr> </table>	1:	10.5x	↗	2:	10.4x	→	Serie	20.9	Total	137.8																																				
1:	9.9	→																																																								
2:	9.6	↗																																																								
Serie	19.5																																																									
Total	116.9																																																									
1:	10.5x	↗																																																								
2:	10.4x	→																																																								
Serie	20.9																																																									
Total	137.8																																																									
<p>5. Serie Skott</p> 	<table border="1" style="width:100%; border-collapse: collapse;"> <tr><td>1:</td><td>10.1</td><td>↗</td></tr> <tr><td>2:</td><td>9.6</td><td>↗</td></tr> </table> <table border="1" style="width:100%; border-collapse: collapse; margin-top: 5px;"> <tr><td>Serie</td><td>19.7</td></tr> <tr><td>Total</td><td>157.5</td></tr> </table>	1:	10.1	↗	2:	9.6	↗	Serie	19.7	Total	157.5	<p>6. Serie Skott</p>  <table border="1" style="width:100%; border-collapse: collapse;"> <tr><td>1:</td><td>9.9</td><td>←</td></tr> <tr><td>2:</td><td>10.3x</td><td>←</td></tr> </table> <table border="1" style="width:100%; border-collapse: collapse; margin-top: 5px;"> <tr><td>Serie</td><td>20.2</td></tr> <tr><td>Total</td><td>177.7</td></tr> </table>	1:	9.9	←	2:	10.3x	←	Serie	20.2	Total	177.7																																				
1:	10.1	↗																																																								
2:	9.6	↗																																																								
Serie	19.7																																																									
Total	157.5																																																									
1:	9.9	←																																																								
2:	10.3x	←																																																								
Serie	20.2																																																									
Total	177.7																																																									
<p>7. Serie Skott</p> 	<table border="1" style="width:100%; border-collapse: collapse;"> <tr><td>1:</td><td>9.3</td><td>→</td></tr> <tr><td>2:</td><td>9.3</td><td>↑</td></tr> </table> <table border="1" style="width:100%; border-collapse: collapse; margin-top: 5px;"> <tr><td>Serie</td><td>18.6</td></tr> <tr><td>Total</td><td>196.3</td></tr> </table>	1:	9.3	→	2:	9.3	↑	Serie	18.6	Total	196.3	<p>8. Serie Skott</p>  <table border="1" style="width:100%; border-collapse: collapse;"> <tr><td>1:</td><td>9.4</td><td>↑</td></tr> <tr><td>2:</td><td>9.8</td><td>↓</td></tr> </table> <table border="1" style="width:100%; border-collapse: collapse; margin-top: 5px;"> <tr><td>Serie</td><td>19.2</td></tr> <tr><td>Total</td><td>215.5</td></tr> </table>	1:	9.4	↑	2:	9.8	↓	Serie	19.2	Total	215.5																																				
1:	9.3	→																																																								
2:	9.3	↑																																																								
Serie	18.6																																																									
Total	196.3																																																									
1:	9.4	↑																																																								
2:	9.8	↓																																																								
Serie	19.2																																																									
Total	215.5																																																									