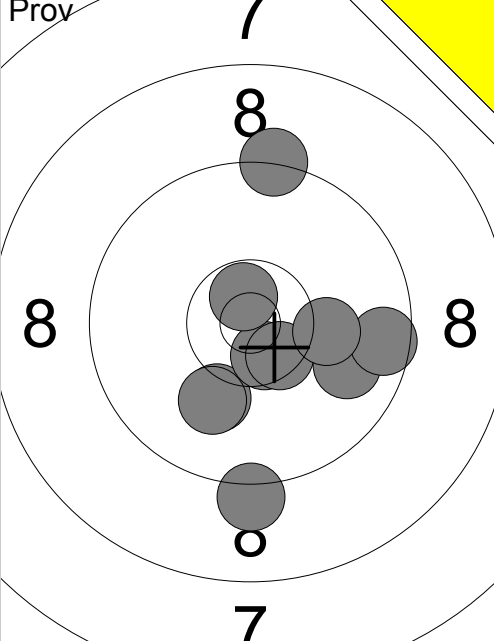
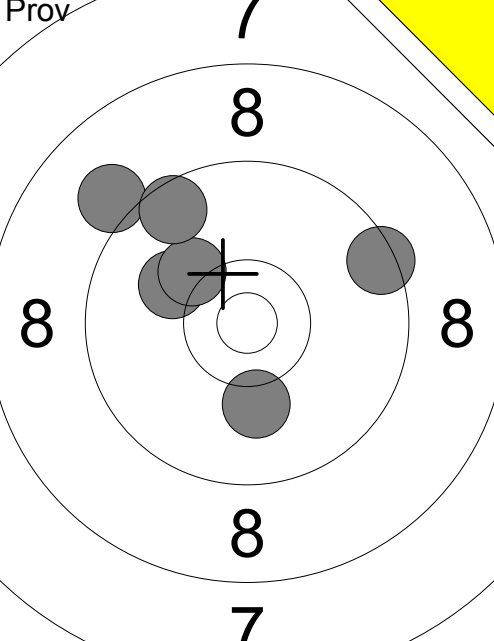
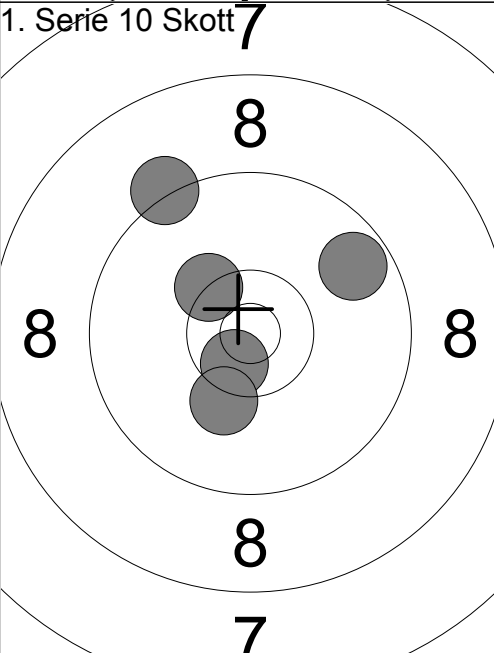
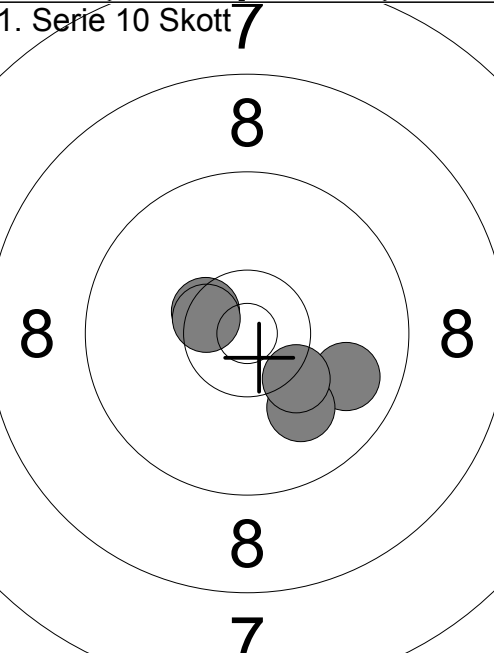

	<p>1: 10.7x →</p> <p>2: 9.8 ←</p> <p>3: 10.0 ↙</p> <p>4: 10.3x ↓</p> <p>5: 10.4x ↑</p> <p>6: 8.6 ↗</p> <p>7: 8.6 ↗</p> <p>8: 8.8 ↗</p> <p>9: 9.1 →</p> <p>10: 9.2 ↓</p>	
Serie 91		Serie 26
Total 198		Total 198

<p>1. Serie 10 Skott <b>7</b></p>	<p>1: 9.6 ↗</p> <p>2: 9.1 ↓</p> <p>3: 10.6x ↙</p> <p>4: 9.7 ←</p> <p>5: 10.6x ↓</p>	<p>1. Serie 10 Skott <b>7</b></p>
Serie 47		Serie 49
Total 245		Total 294

<p>2. Serie 1 Skott <b>7</b></p>	<p>1: 9.8 ↑</p> <p>2: 10.2 ↓</p> <p>3: 9.9 ↙</p> <p>4: 9.6 →</p> <p>5: 10.2 →</p>	
Serie 47		
Total 341		

<p>Prov</p> 	<p>1: 9.2 ↓                  2: 9.3 ↑                  3: 9.9 →                  4: 10.1 ↓                  5: 10.6x ↓                  6: 9.6 →                  7: 10.5x ↓                  8: 10.2 →                  9: 10.7x ↑                  10: 10.1 ↓</p>	<p>Prov</p> 
Serie 96		Serie 57
Total 195		Total 195

<p>1. Serie 10 Skott</p> 	<p>1: 10.3x ↖                  2: 9.7 ↗                  3: 10.6x ↓                  4: 9.2 ↗                  5: 10.2 ↓</p>	<p>1. Serie 10 Skott</p> 
Serie 48		Serie 49
Total 243		Total 292

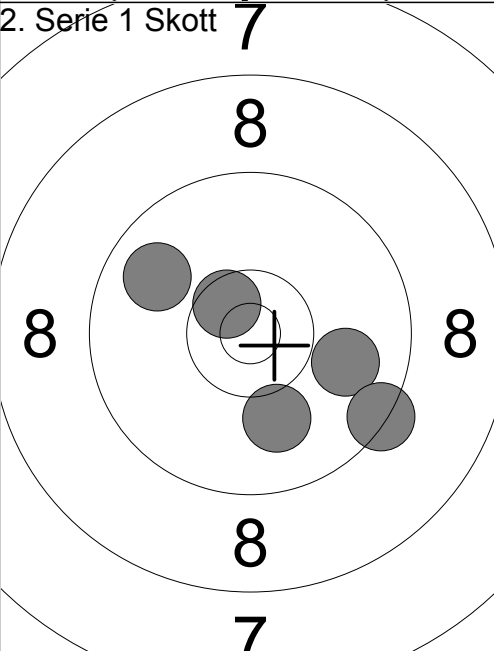
<p>2. Serie 1 Skott</p> 	<p>1: 9.9 →                  2: 10.6x ↗                  3: 9.8 ↗                  4: 9.4 ↓                  5: 10.0 ↓</p>	
Serie 47		
Total 339		

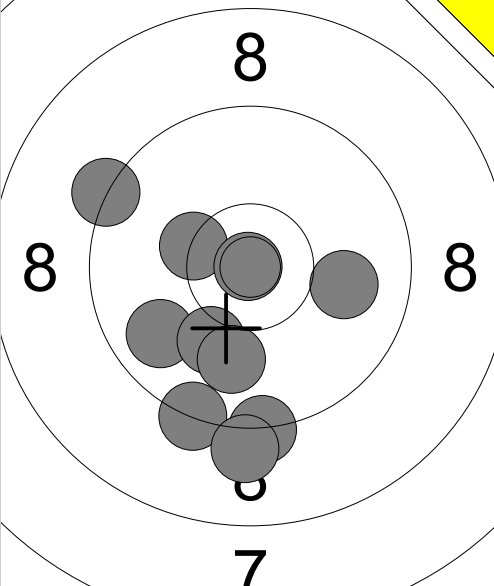
	<p>1: 9.3 ↓</p> <p>2: 9.3 ↓</p> <p>3: 10.3x ←</p> <p>4: 9.1 ↓</p> <p>5: 9.3 ↖</p> <p>6: 10.9x ↖</p> <p>7: 10.0 →</p> <p>8: 9.8 ↙</p> <p>9: 10.1 ↓</p> <p>10: 10.0 ↓</p>	<p>11: 10.0 ↙</p> <p>12: 10.4x ↓</p> <p>13: 9.6 ↓</p> <p>14: 10.4x ↖</p> <p>15: 10.2 ↙</p> <p>16: 10.3 →</p> <p>17: 9.6 ↖</p>
Serie 95		Serie 68
Total 193		Total 193

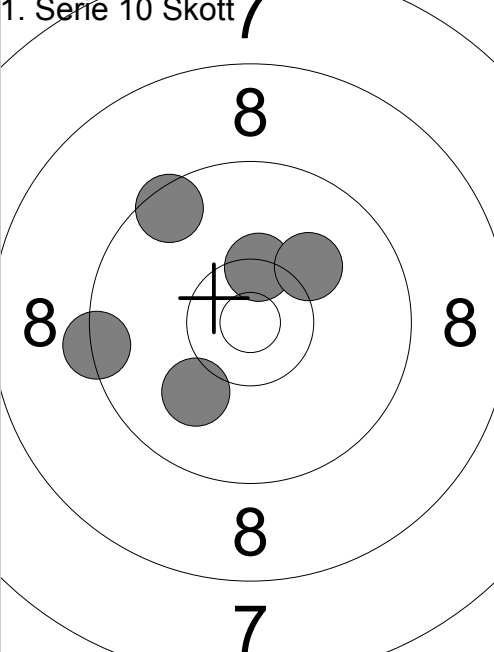
<p>1. Serie 10 Skott</p> 	<p>1: 9.5 ↖</p> <p>2: 10.0 ↙</p> <p>3: 9.4 ←</p> <p>4: 10.4x ↑</p> <p>5: 10.1 ↗</p>	<p>6: 10.5x ←</p> <p>7: 10.5x ↖</p> <p>8: 10.8x →</p> <p>9: 9.5 →</p> <p>10: 9.6 ↙</p>
Serie 48		Serie 48
Total 241		Total 289

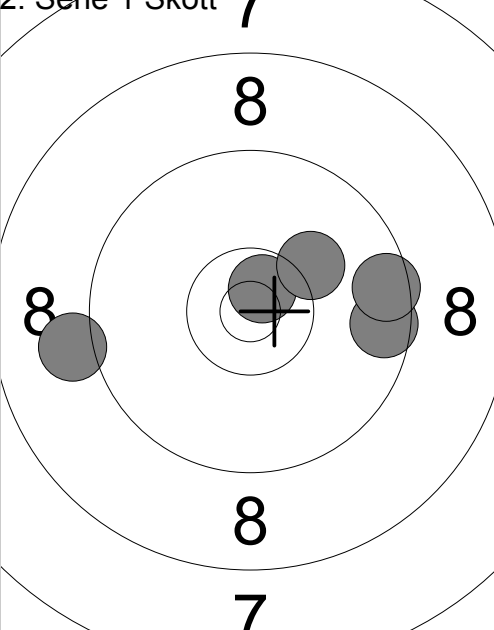
<p>2. Serie 1 Skott</p> 	<p>1: 9.6 →</p> <p>2: 10.7x ↗</p> <p>3: 9.1 ←</p> <p>4: 9.5 →</p> <p>5: 10.2 ↗</p>	
Serie 47		
Total 336		

<p>Prov</p>	<p>1: 10.6x ↗                  2: 8.2 ↓                  3: 8.7 ↓                  4: 9.1 ↓                  5: 10.5x ↙                  6: 10.0 ↗                  7: 9.1 ↑                  8: 9.3 ↖                  9: 9.1 →                  10: 10.5x ↗</p>	<p>Prov</p>
	Serie 92	Serie 28
	Total 192	Total 192

<p>1. Serie 10 Skott</p>	<p>1: 10.6x ↖                  2: 10.3x ↓                  3: 10.1 ↓                  4: 10.6x ↙                  5: 10.1 ↑</p>	<p>1. Serie 10 Skott</p>
	Serie 50	Serie 48
	Total 242	Total 290

<p>2. Serie 1 Skott</p>	<p>1: 10.3 ↑                  2: 9.7 →                  3: 10.1 ↙                  4: 9.9 ↓                  5: 10.5x →</p>	
	Serie 48	
	Total 338	

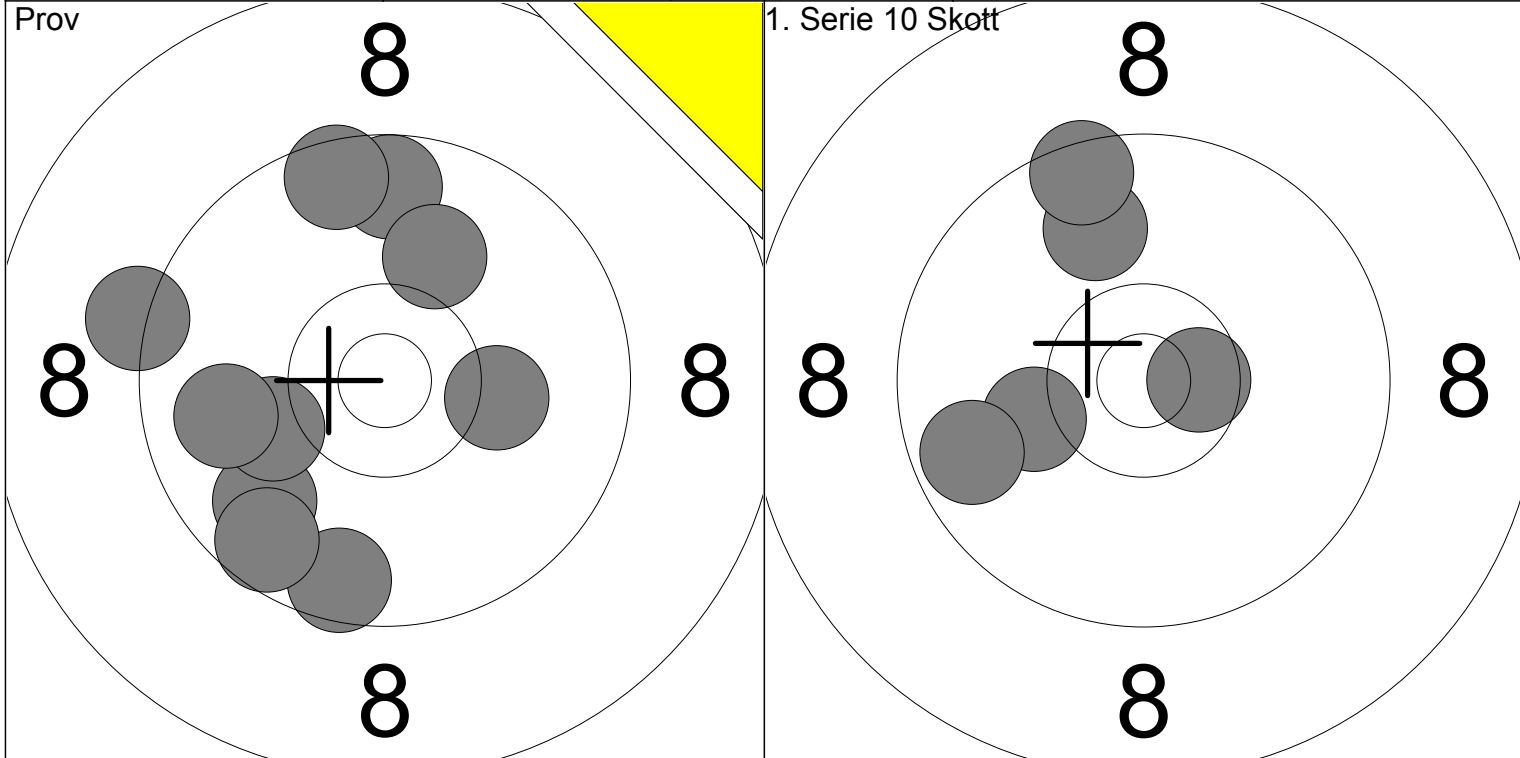

1: 9.6 ↓	6: 9.6 ↑			1: 10.2 ←			
2: 9.8 ↙	7: 10.1 ←	Serie	93	2: 9.9 ↑		Serie	47
3: 9.6 ↘	8: 9.5 ↑	Total	189	3: 9.7 ←		Total	236
4: 10.2 →	9: 10.1 ↑			4: 9.5 ↑			
5: 9.2 ←	10: 9.9 ←			5: 10.6x →			

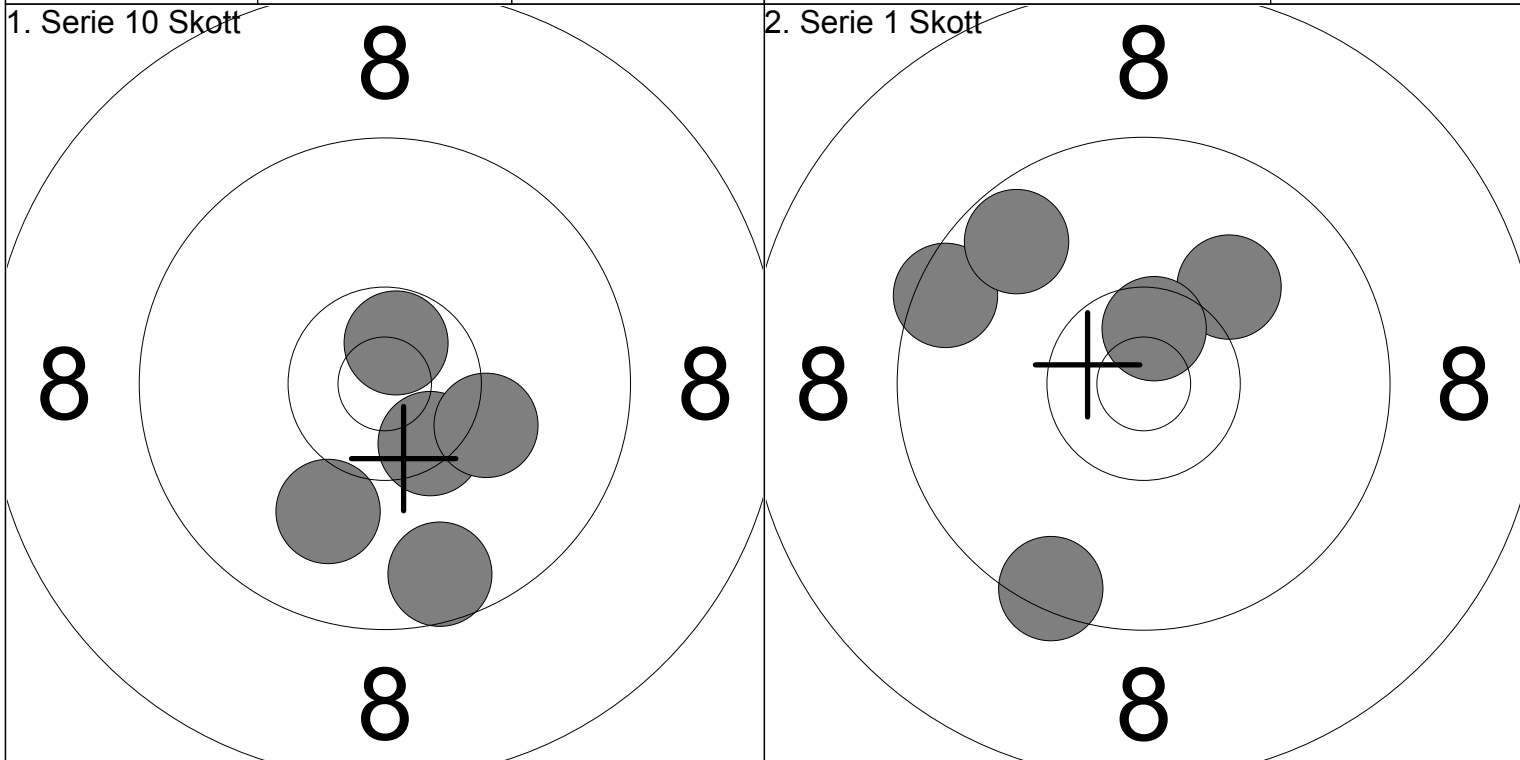

6: 10.7x ↑				1: 9.5 ←			
7: 10.4x ↘		Serie	49	2: 9.4 ↓		Serie	47
8: 9.6 ↘		Total	285	3: 9.7 ↑		Total	332
9: 10.2 ↘				4: 10.1 ↑			
10: 10.0 ↓				5: 10.6x ↑			

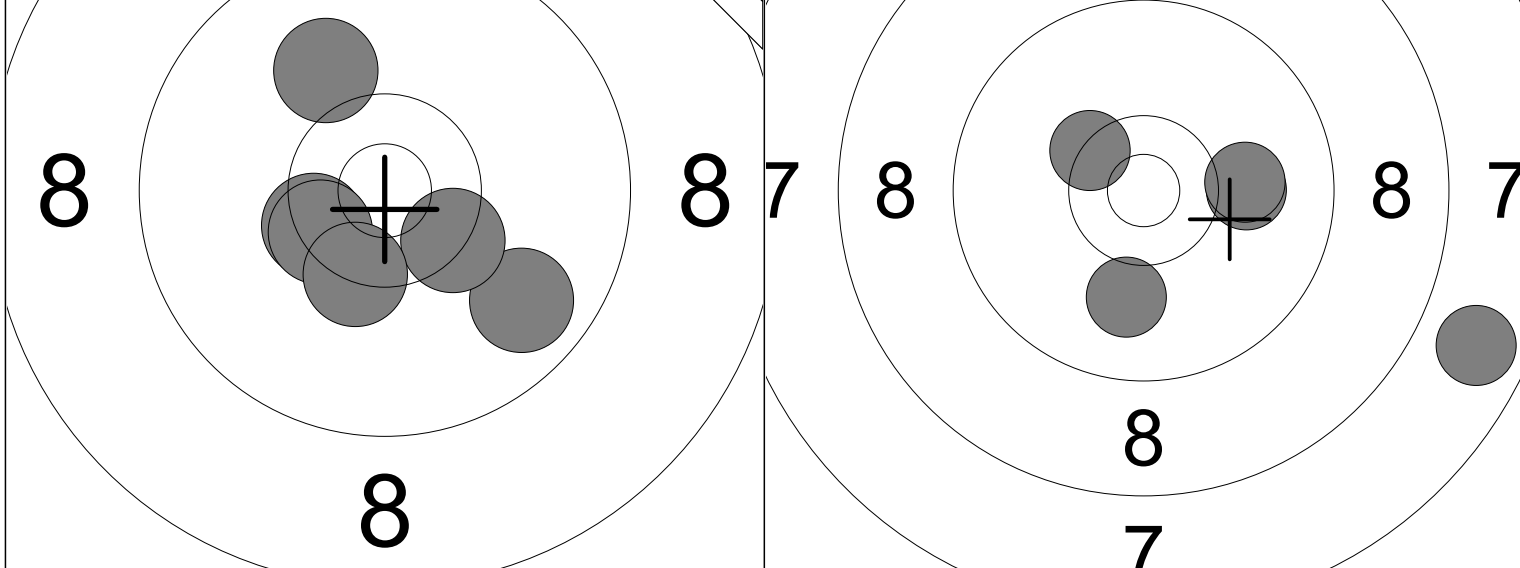

1: 10.4x ↙	6: 10.4x ↓	Serie	59	1: 10.1 →	Serie	47
2: 10.1 ↗				2: 10.0 ↓		
3: 9.8 ↘				3: 10.1 →		
4: 10.4x ↙		Total	191	4: 10.4x ↗	Total	238
5: 10.4x ↘				5: 7.8 ↘		

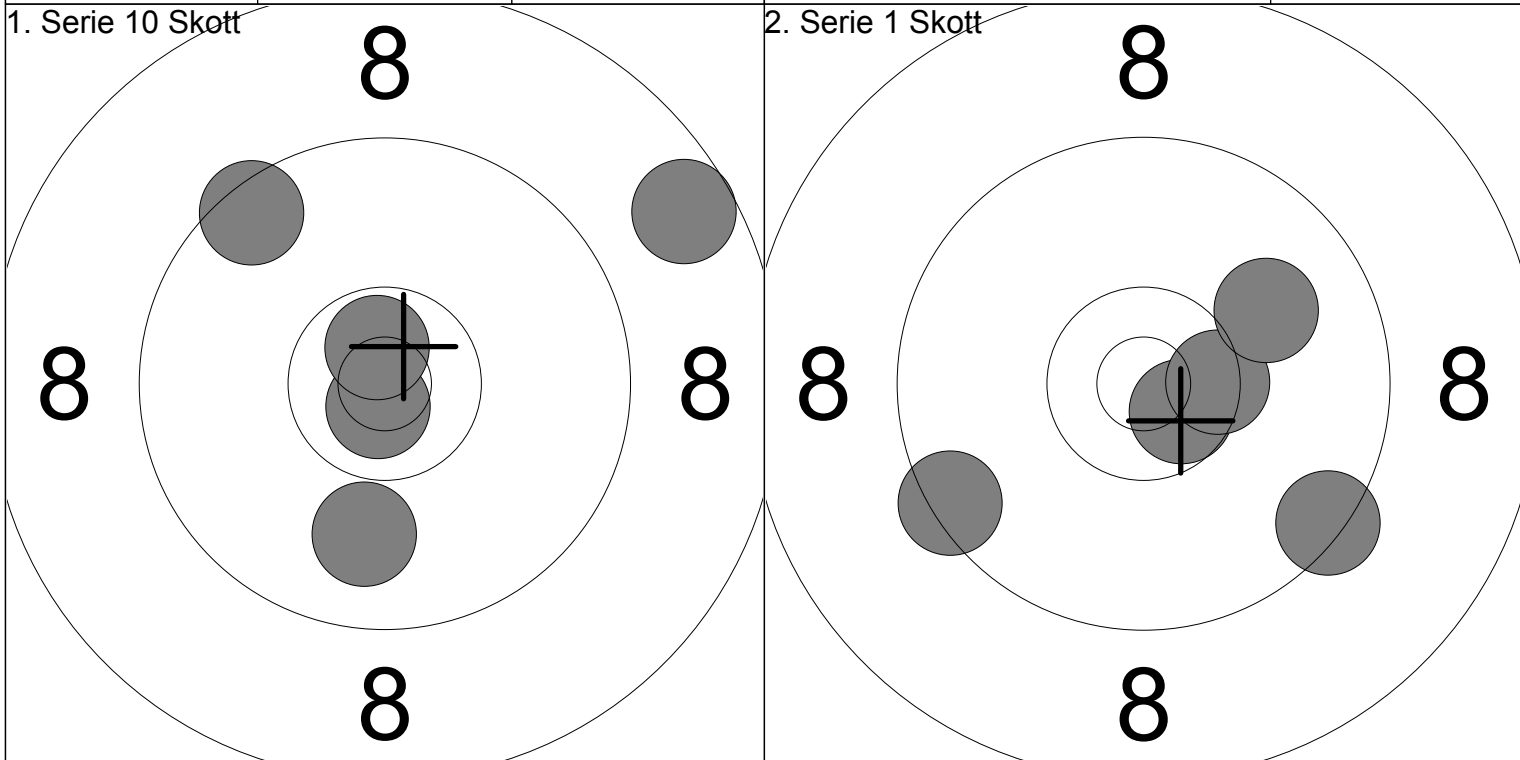

6: 9.9 ↓	7: 10.8x ↓	8: 9.5 ↗	9: 10.7x ↗	10: 8.6 ↗	Serie	46	1: 9.4 ↘	2: 10.6x ↘	3: 9.4 ↙	4: 10.5x →	5: 10.0 ↗	Serie	48
					Total	284						Total	332

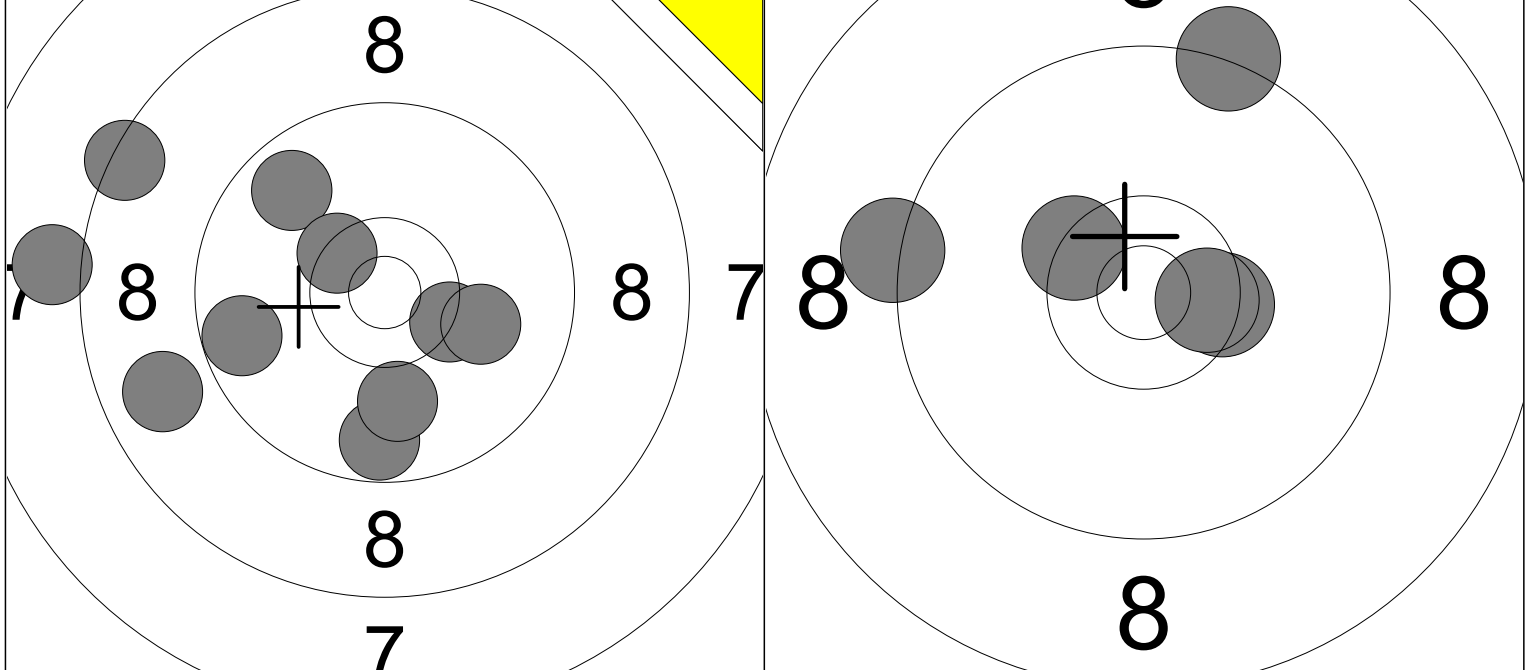

1: 9.7 ↓	6: 10.1 →			1: 9.3 ↑			
2: 9.7 ↗	7: 8.4 ↗	Serie	91	2: 9.2 ←	Serie	48	
3: 8.1 ←	8: 9.7 ←			3: 10.4x →			
4: 8.8 ←	9: 10.0 ↓	Total	189	4: 10.4x ↗	Total	237	
5: 10.3x ↘	10: 10.4x ↗			5: 10.5x →			

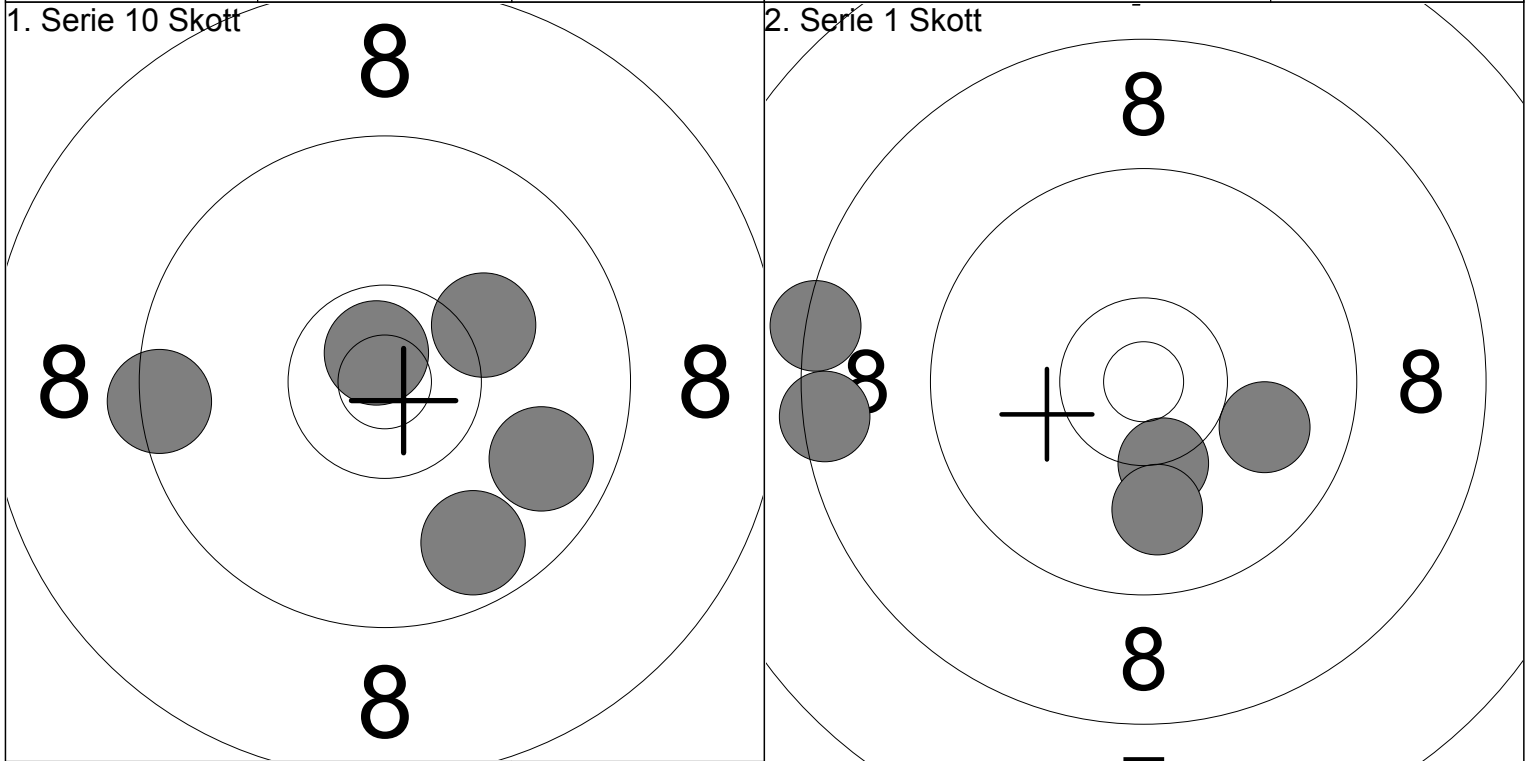

6: 9.7 ↘				1: 8.5 ←			
7: 9.4 ←		Serie	47	2: 9.9 →	Serie	45	
8: 10.7x ↗				3: 8.4 ←			
9: 10.2 ↗		Total	284	4: 10.3x ↓	Total	329	
10: 9.8 ↘				5: 10.0 ↓			

<p>Prov</p>	<p>1: 8.0 →</p> <p>2: 9.5 ↓</p> <p>3: 10.6x ←</p> <p>4: 8.3 →</p> <p>5: 10.6x ↑</p> <p>6: 10.4x →</p> <p>7: 10.4x ↓</p> <p>8: 9.5 →</p> <p>9: 10.6x ↓</p> <p>10: 10.0 ←</p>	<p>Prov</p>	
Serie 94		11: 10.5x ↗	
Total 188		Serie 10	
		Total 188	

<p>1. Serie 10 Skott 7</p>	<p>1: 9.3 ↗</p> <p>2: 9.6 →</p> <p>3: 10.7x ←</p> <p>4: 10.6x →</p> <p>5: 10.3x ↑</p>	<p>1. Serie 10 Skott 7</p>	
Serie 48		6: 10.4x ↓	
Total 236		7: 10.0 →	
		8: 9.6 ↓	
		9: 9.7 ←	
		10: 10.1 ←	
Serie 47		Serie 48	
Total 331		Total 284	

<p>2. Serie 1 Skott 7</p>	<p>1: 10.0 ↓</p> <p>2: 9.7 ↗</p> <p>3: 9.9 ↗</p> <p>4: 9.5 →</p> <p>5: 10.3x ↓</p>	
Serie 47		
Total 331		

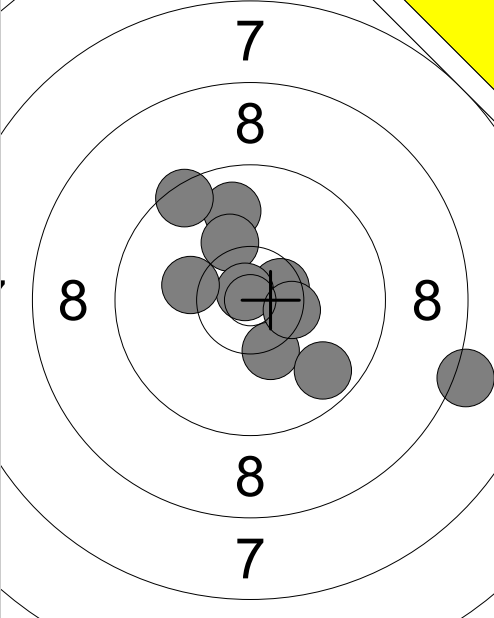
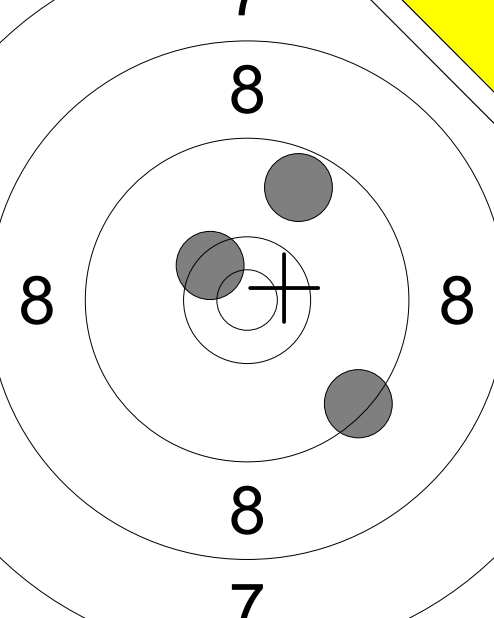

<p>Pröv</p> 	<p>1: 10.6x →</p> <p>2: 9.8 ↑</p> <p>3: 10.3x ↓</p> <p>4: 10.2 ↑</p> <p>5: 9.7 ↓</p> <p>6: 8.2 →</p> <p>7: 10.8x ↗</p> <p>8: 9.5 ↗</p> <p>9: 10.2 ←</p> <p>10: 10.4x →</p>	<p>Pröv</p> 	
Serie	95	Serie	28
Total	187	Total	187

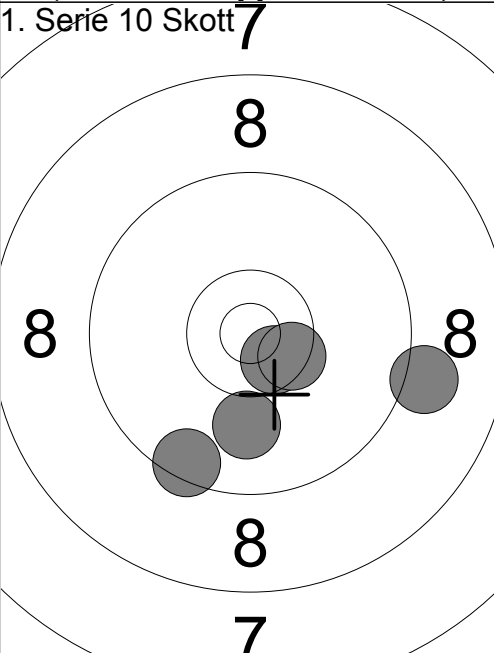
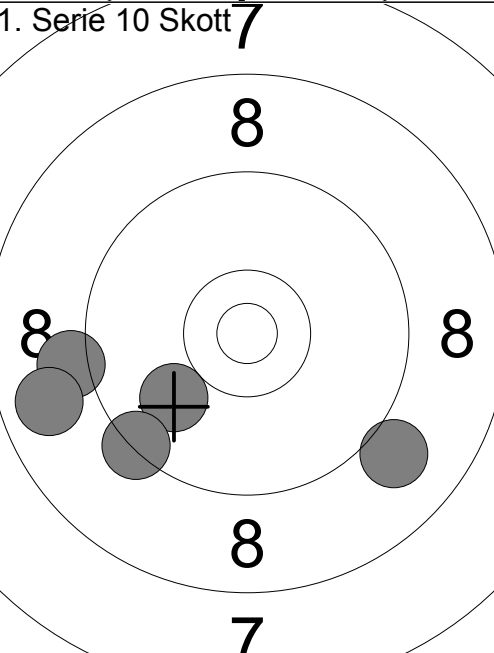
<p>1. Serie 10 Skott</p> 	<p>1: 10.6x ↓</p> <p>2: 9.5 ↓</p> <p>3: 10.5x →</p> <p>4: 10.0 ↓</p> <p>5: 9.1 →</p>	<p>1. Serie 10 Skott</p> 	
Serie	48	Serie	45
Total	235	Total	280

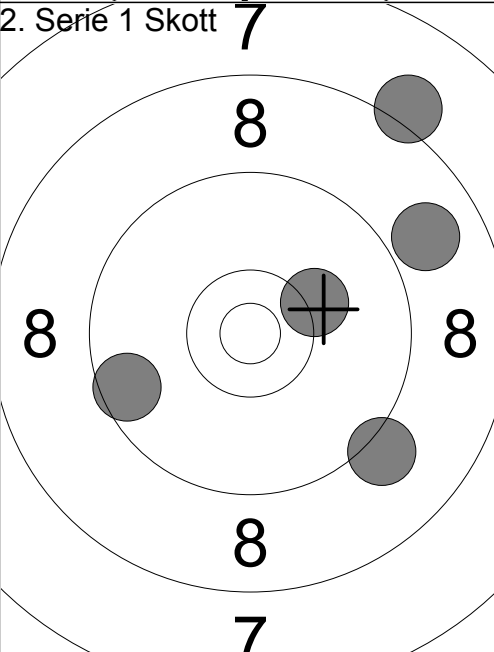
<p>2. Serie 1 Skott</p> 	<p>1: 9.1 ↓</p> <p>2: 8.1 ↗</p> <p>3: 8.9 ↗</p> <p>4: 10.2 ↗</p> <p>5: 9.6 ←</p>	
Serie	44	
Total	324	

<p>Prov</p>	<p>1: 8.9 ←                  2: 10.1 ↗                  3: 9.8 →                  4: 10.5x →                  5: 10.7x ↗                  6: 9.9 ↓                  7: 10.6x ↓                  8: 10.1 ↗                  9: 8.3 →                  10: 10.5x ↓</p>	<p>11: 9.2 ↖</p>
Serie 94		Serie 9
Total 185		Total 185

<p>1. Serie 10 Skott</p>	<p>1: 10.1 ←                  2: 9.5 ↓                  3: 9.8 ↘                  4: 10.0 ↓                  5: 9.1 ←</p>	<p>6: 10.3x ↗                  7: 10.4x ↗                  8: 10.4x ↖                  9: 10.3 ↗                  10: 9.6 ↓</p>
Serie 47		Serie 49
Total 232		Total 281

<p>2. Serie 1 Skott</p>	<p>1: 9.2 ←                  2: 10.2 ←                  3: 10.1 ↘                  4: 9.3 →                  5: 9.8 ←</p>	
Serie 47		
Total 328		

<p>Prov</p>	<p>1: 8.4 ↙                  2: 10.0 ↖                  3: 9.1 ↓                  4: 9.0 ↖                  5: 9.7 ↗                  6: 10.4x →                  7: 9.7 →                  8: 10.1 ↗                  9: 8.8 ↑                  10: 8.8 →</p> <p>Serie 90 Total 180</p>	<p>Prov</p>	<p>11: 10.4x ↑                  12: 9.3 ↖                  13: 9.2 ↖                  14: 9.3 ↖                  15: 9.0 ↖                  16: 9.8 ↑</p> <p>Serie 55 Total 180</p>
-------------	----------------------------------------------------------------------------------------------------------------------------------------------------------------------------------------------------------------------------------------------------------------------------------------------------------------------------------	-------------	-------------------------------------------------------------------------------------------------------------------------------------------------------------------------------------------------------------

<p>1. Serie 10 Skott 5</p>	<p>1: 9.6 ↗                  2: 9.6 ↗                  3: 8.6 ↓                  4: 6.5 ↗                  5: 9.1 ↗</p> <p>Serie 41 Total 221</p>	<p>1. Serie 10 Skott 7</p>	<p>6: 8.6 ↘                  7: 10.2 ↑                  8: 9.6 ↖                  9: 9.8 ↗                  10: 9.7 ←</p> <p>Serie 45 Total 266</p>
----------------------------	-----------------------------------------------------------------------------------------------------------------------------------------------------------------------	----------------------------	-------------------------------------------------------------------------------------------------------------------------------------------------------------------------

<p>2. Serie 1 Skott</p>	<p>1: 8.4 ↖                  2: 9.4 →                  3: 10.1 →                  4: 9.9 ↓                  5: 10.3x ←</p> <p>Serie 46 Total 312</p>		
-------------------------	--------------------------------------------------------------------------------------------------------------------------------------------------------------------------	--	--

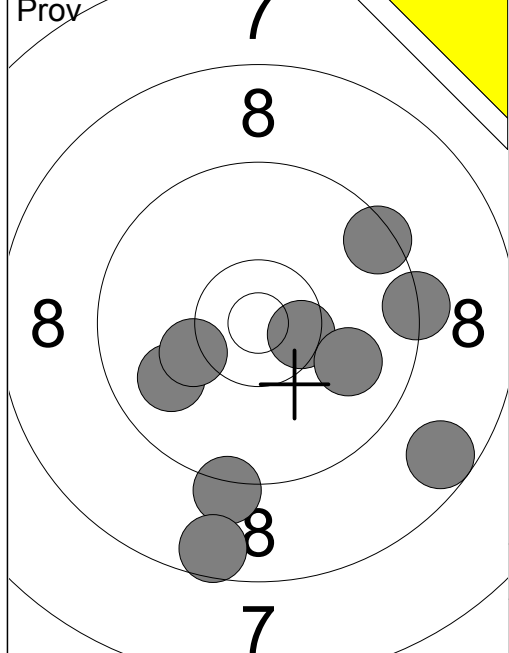

1:	9.2	↓
2:	10.5x	→
3:	9.9	↙
4:	9.9	→
6:	10.2	↙
7:	9.3	→
8:	8.7	↘
9:	8.6	↓
10:	9.5	↗

Serie	81
Total	176

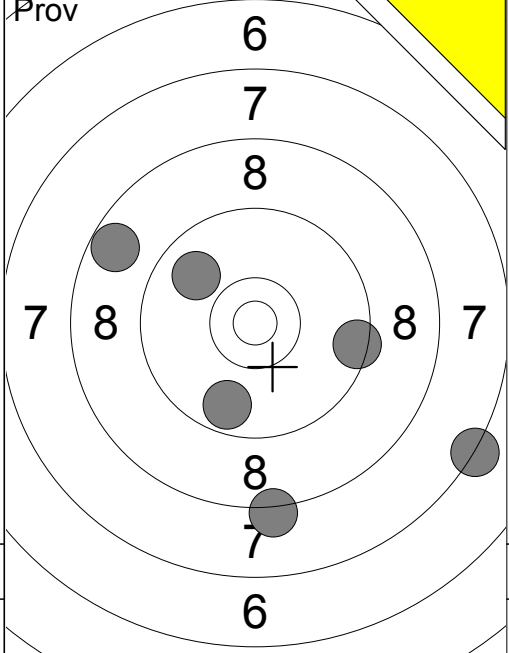

11:	8.2	↓
12:	9.7	↓
13:	7.3	↘
14:	9.4	→
15:	8.7	↗
16:	9.9	↗

Serie	50
Total	176

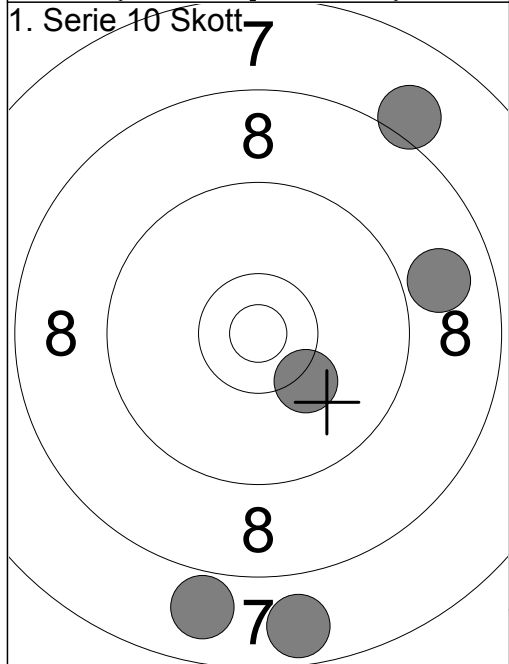

1:	8.1	↗
2:	7.9	↓
3:	10.2	↘
4:	8.9	→
5:	7.7	↓

Serie	40
Total	216

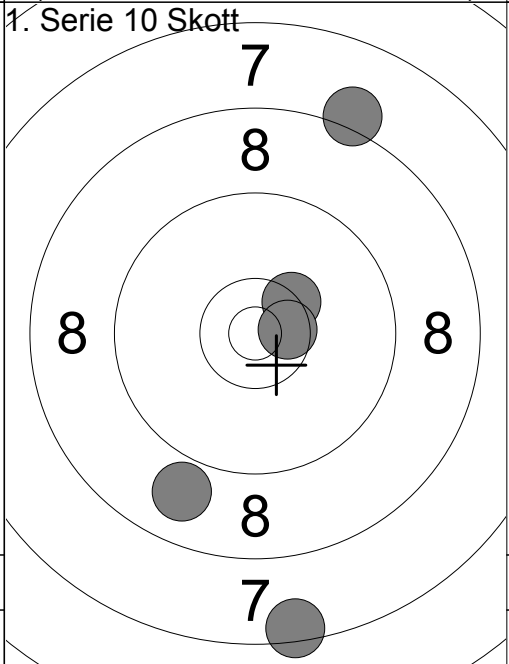

6:	8.9	↓
7:	10.4x	↗
8:	7.5	↓
9:	10.6x	→
10:	8.2	↗

Serie	43
Total	259

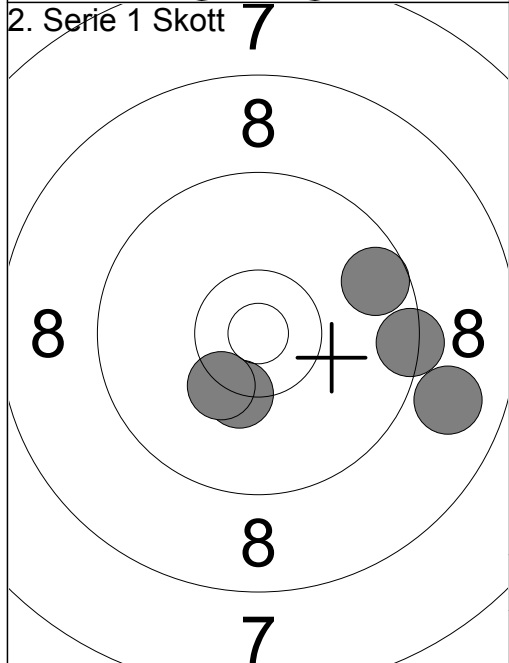

1:	10.3x	↓
2:	10.3x	↙
3:	9.6	→
4:	8.9	→
5:	9.4	→

Serie	46
Total	305

Prov 	1: 9.5 ← 2: 9.9 → 3: 9.6 → 4: 10.6x ↖ 5: 10.8x → 6: 10.5x ↙ 7: 9.0 → 8: 9.4 ↓ 9: 9.5 → 10: 10.3 ↙ Serie 94 Total 184	Prov 	11: 10.3 ↗ 12: 10.3x ↗ Serie 20 Total 184
----------	-------------------------------------------------------------------------------------------------------------------------------------------------------	----------	----------------------------------------------------

1. Serie 10 Skott 	1: 10.1 ↙ 2: 10.4x ↓ 3: 9.0 ↘ 4: 9.3 ↓ 5: 8.6 → Serie 46 Total 230	1. Serie 10 Skott 	6: 10.1 ← 7: 10.1 → 8: 9.6 → 9: 10.6x ← 10: 9.2 ↗ Serie 48 Total 278
-----------------------	--------------------------------------------------------------------------------------	-----------------------	----------------------------------------------------------------------------------------

2. Serie 1 Skott 	1: 9.6 ↙ 2: 10.6x ← 3: 10.4x ↗ 4: 9.5 ↖ 5: 10.1 ↙ Serie 48 Total 326		
----------------------	----------------------------------------------------------------------------------------	--	--

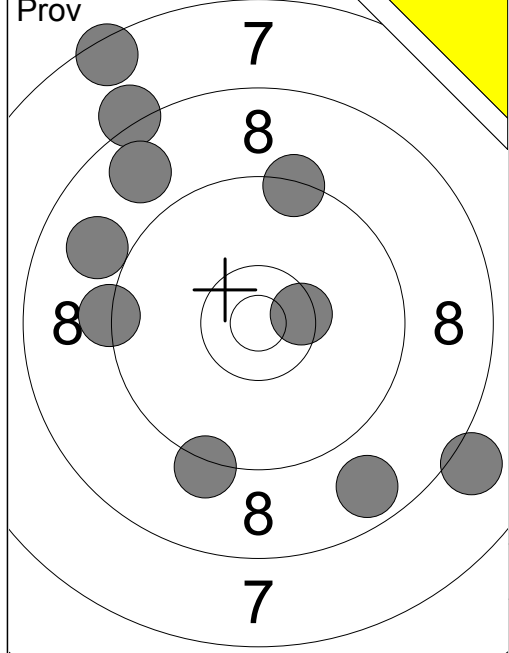

1:	7.5	↗
2:	8.1	↘
3:	8.2	↗
4:	8.9	↖
5:	9.3	↗
6:	9.2	↘
7:	8.7	↘
8:	8.8	↗
9:	9.3	↖
10:	10.5x	→
Serie		84
Total		159

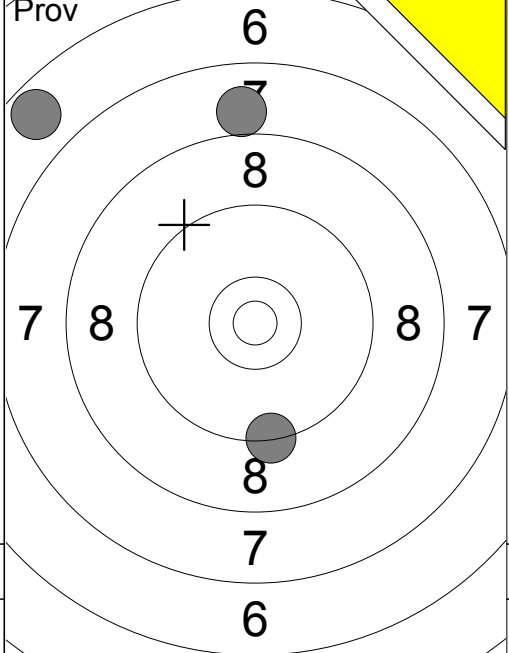

11:	9.3	↘
12:	8.0	↗
13:	6.7	↖
Serie		23
Total		159

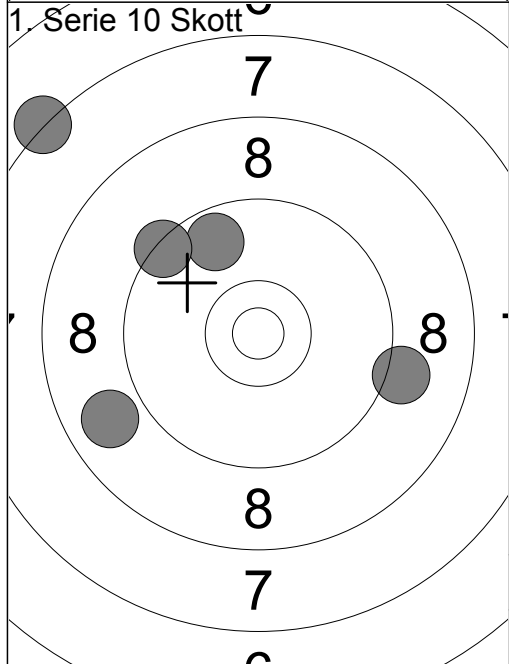

1:	9.7	↗
2:	9.1	→
3:	9.4	↗
4:	7.3	↗
5:	8.8	↖
Serie		42
Total		201

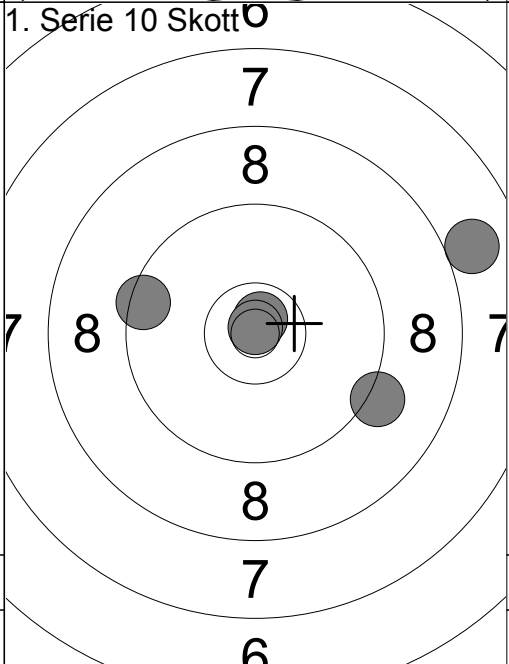

6:	9.5	↖
7:	8.0	↗
8:	9.2	↘
9:	10.8x	↗
10:	10.9x	↗
Serie		46
Total		247

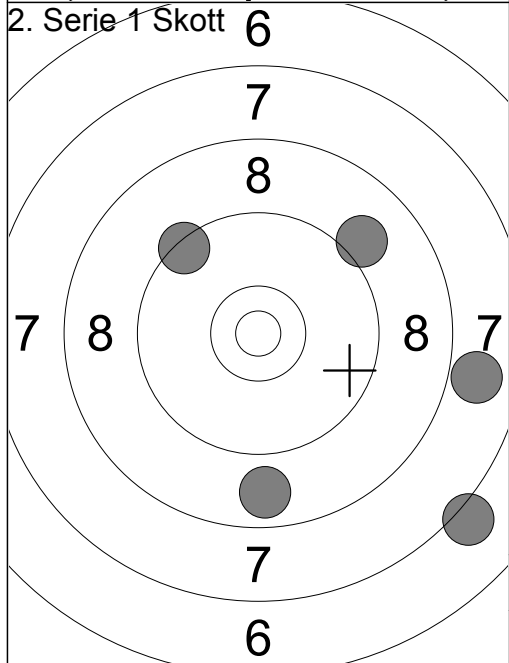

1:	9.1	↗
2:	8.8	↘
3:	9.4	↗
4:	7.9	→
5:	7.1	↘
Serie		40
Total		287

Prov 	1: 9.2 ↘ 2: 9.3 ← 3: 7.8 ↘ 4: 9.6 ↗ 5: 10.1 ↘ 6: 8.9 ↘ 7: 10.0 ↘ 8: 10.5x ↘ 9: 10.2 ↘ 10: 9.6 ↗ Serie 91 Total 182	Prov 	11: 9.4 → 12: 10.2 ← 13: 9.8 ↘ 14: 8.9 ↑ 15: 9.3 ↘ 16: 9.4 ↘ 17: 9.5 ↘ Serie 63 Total 182
----------	-----------------------------------------------------------------------------------------------------------------------------------------------------	----------	-------------------------------------------------------------------------------------------------------------------

1. Serie 10 Skott 	1: 9.2 ↗ 2: 8.0 ↘ 3: 9.9 ↘ 4: 10.2 ← 5: 10.5x → Serie 46 Total 228	1. Serie 10 Skott 	6: 10.4x ↘ 7: 10.7x ↑ 8: 9.8 → 9: 9.6 ↘ 10: 9.8 ↘ Serie 47 Total 275
-----------------------	--------------------------------------------------------------------------------------	-----------------------	----------------------------------------------------------------------------------------

2. Serie 1 Skott 	1: 10.4x ← 2: 9.4 ↗ 3: 9.4 ↗ 4: 8.2 ↘ 5: 9.9 ↘ Serie 45 Total 320		
----------------------	-------------------------------------------------------------------------------------	--	--

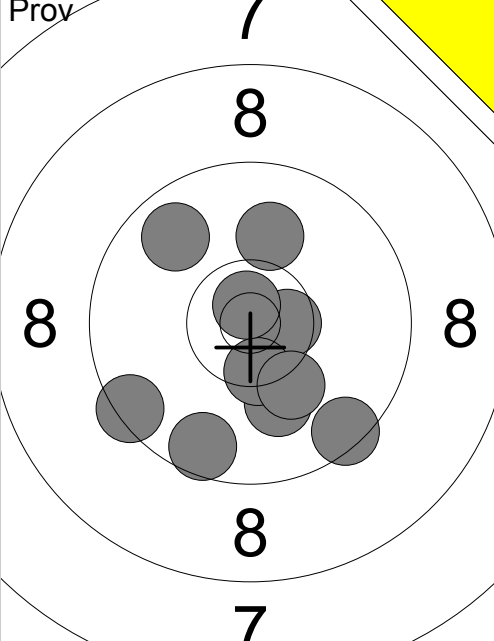
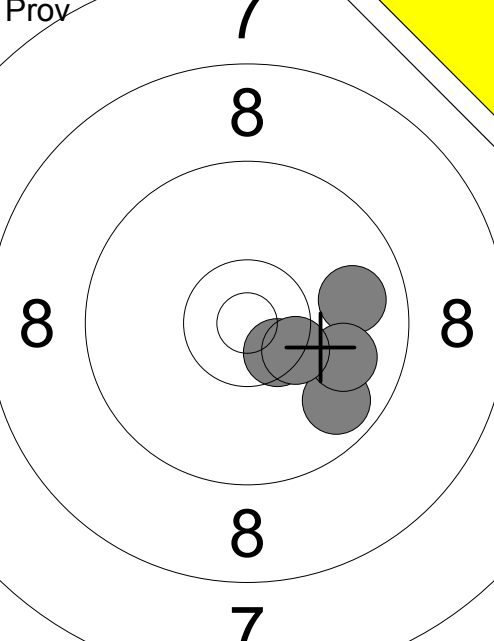
<p>Prov</p> 	<p>1: 9.4 ↙                  2: 9.6 ↓                  3: 9.8 ↗                  4: 9.5 ↓                  5: 10.1 ↓                  6: 10.6x →                  7: 10.4x ↓                  8: 10.2 ↓                  9: 10.8x ↑                  10: 10.0 ↑</p>	<p>Prov</p> 
	Serie 96	Serie 47
	Total 181	Total 181

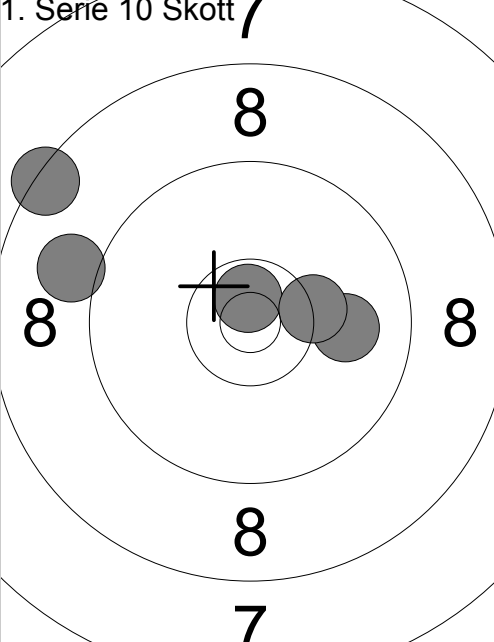
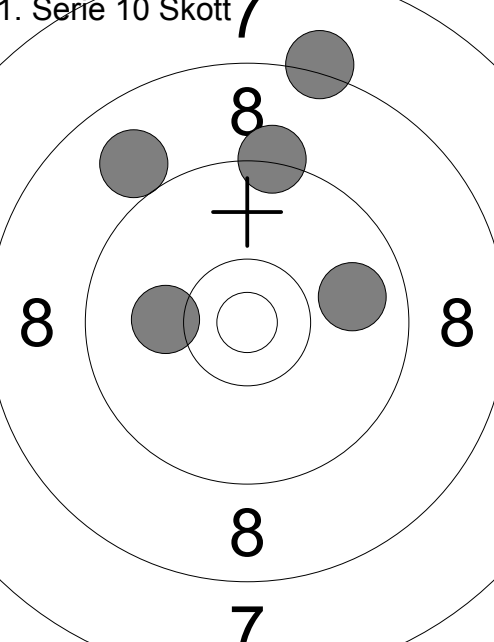
<p>1. Serie 10 Skott</p> 	<p>1: 10.0 →                  2: 10.7x ↑                  3: 10.3x →                  4: 8.4 ↙                  5: 9.0 ↙</p>	<p>1. Serie 10 Skott</p> 
	Serie 47	Serie 45
	Total 228	Total 273

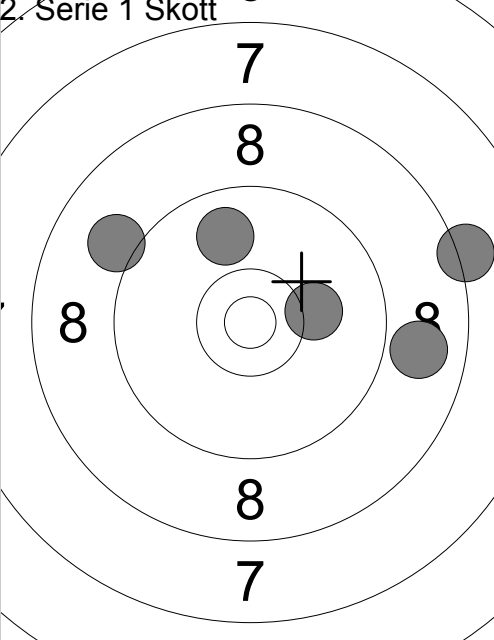
<p>2. Serie 1 Skott</p> 	<p>1: 9.9 ↑                  2: 8.2 →                  3: 9.1 ↙                  4: 10.2 →                  5: 8.9 →</p>	
	Serie 44	
	Total 317	



<p>Prov</p>	<p>1: 10.4x →</p> <p>2: 9.6 ↑</p> <p>3: 9.1 →</p> <p>4: 10.2 ↗</p> <p>5: 9.0 ←</p> <p>6: 10.7x ↘</p> <p>7: 10.1 ↓</p> <p>8: 10.8x ↖</p> <p>9: 9.7 ↗</p> <p>10: 9.7 ↓</p>	<p>Prov</p>	<p>11: 10.1 ↙</p> <p>12: 10.3x ↗</p> <p>13: 10.8x ↖</p>
Serie	95	Serie	30
Total	180	Total	180

<p>1. Serie 10 Skott</p>	<p>1: 9.8 →</p> <p>2: 10.3 ←</p> <p>3: 10.5x →</p> <p>4: 10.2 ↓</p> <p>5: 9.6 ↙</p>	<p>1. Serie 10 Skott</p>	<p>6: 8.9 →</p> <p>7: 9.6 ↖</p> <p>8: 10.3x ↓</p> <p>9: 10.6x ↗</p> <p>10: 9.6 →</p>
Serie	48	Serie	46
Total	228	Total	274

<p>2. Serie 1 Skott</p>	<p>1: 8.4 ↗</p> <p>2: 8.1 ↗</p> <p>3: 6.2 ↖</p> <p>4: 8.3 ↗</p> <p>5: 8.8 ↖</p>		
Serie	38		
Total	312		

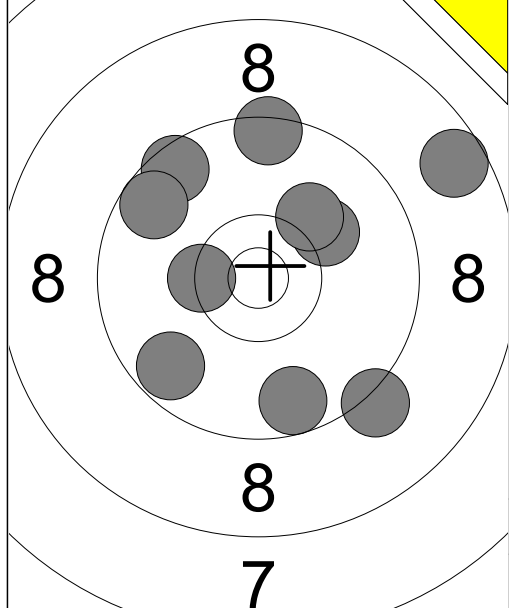

1:	9.2	↘
2:	10.4x	←
3:	9.4	↑
4:	9.5	↖
5:	8.6	→
6:	9.7	↙
7:	10.1	↗
8:	10.1	↗
9:	9.6	↖
10:	9.6	↘
Serie		92
Total		170

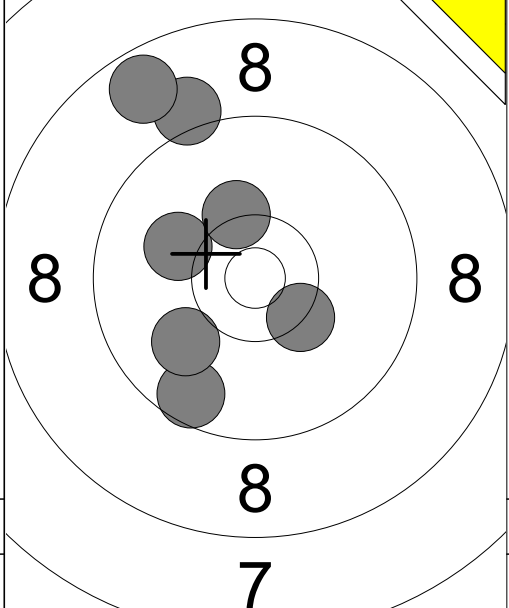

11:	9.6	↙
12:	10.0	↙
13:	9.1	↑
14:	8.7	↗
15:	10.1	↖
16:	10.3	↑
17:	10.3x	↘
Serie		66
Total		170

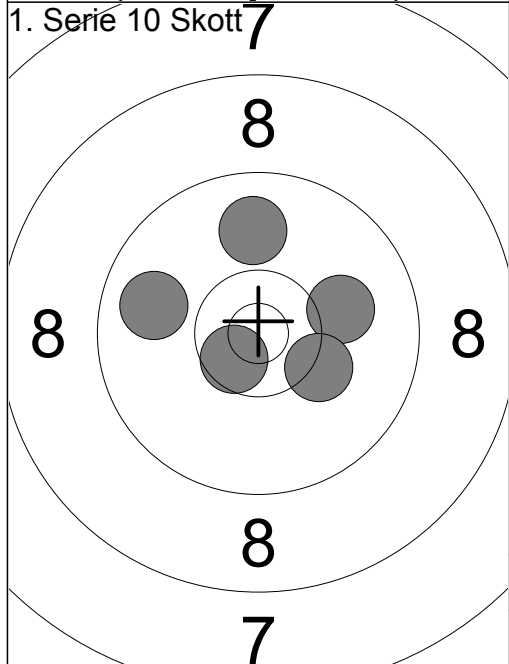

1:	10.1	→
2:	10.2	↘
3:	10.6x	↙
4:	9.9	↑
5:	9.8	←
Serie		48
Total		218

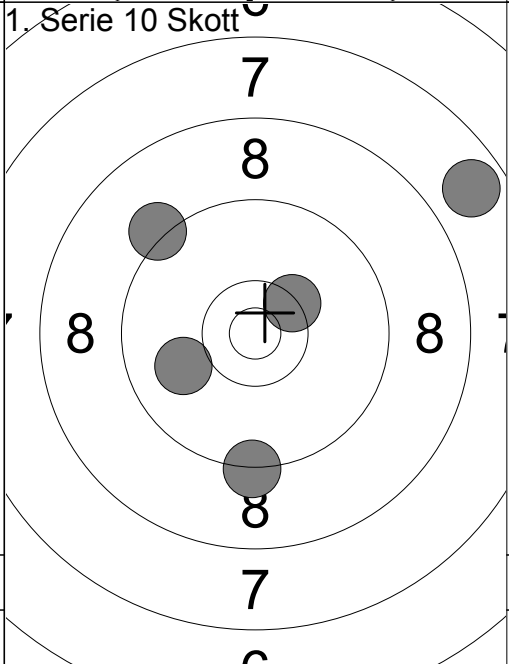

6:	9.2	↖
7:	10.0	←
8:	7.7	↗
9:	9.3	↓
10:	10.4x	↗
Serie		45
Total		263

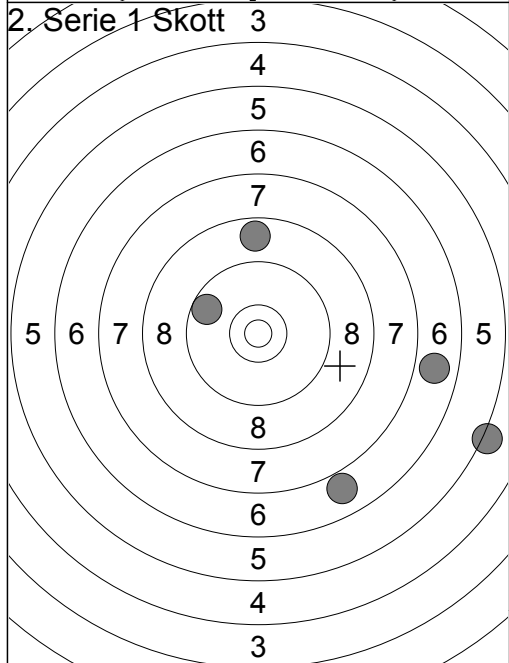

1:	6.8	→
2:	8.7	↑
3:	5.2	↘
4:	9.7	↖
5:	6.9	↘
Serie		34
Total		297

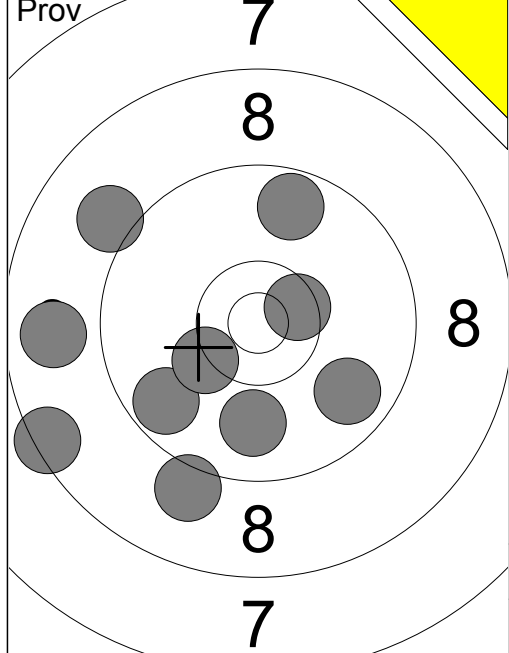

1:	9.1	↘
2:	9.7	↑
3:	10.5x	→
4:	9.9	↓
5:	9.8	↘
6:	8.4	↙
7:	8.8	←
8:	9.1	↗
9:	9.7	↙
10:	10.3	↙
Serie		90
Total		170

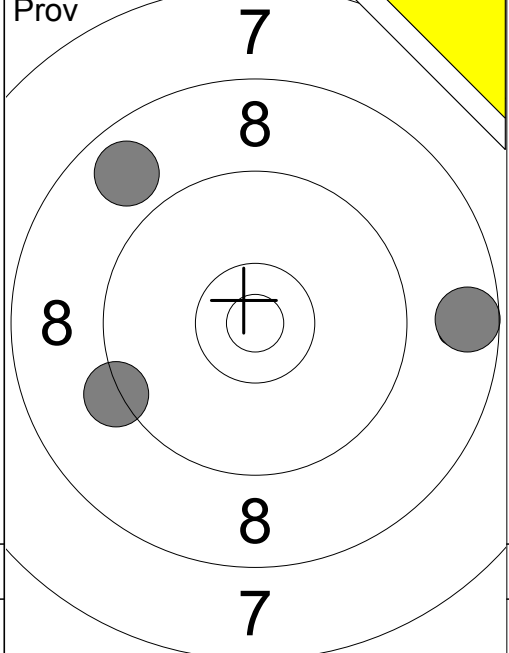

11:	8.8	↗
12:	8.6	→
13:	9.3	↙
Serie		25
Total		170

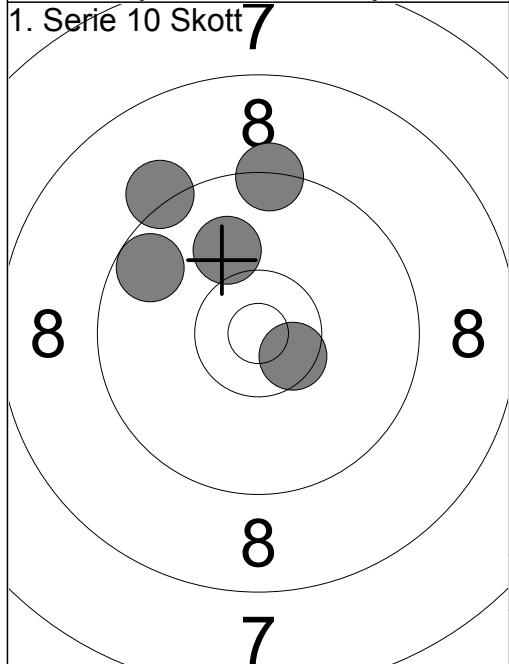

1:	10.5x	↘
2:	9.3	↑
3:	9.7	↙
4:	9.2	↗
5:	10.0	↑
Serie		47
Total		217

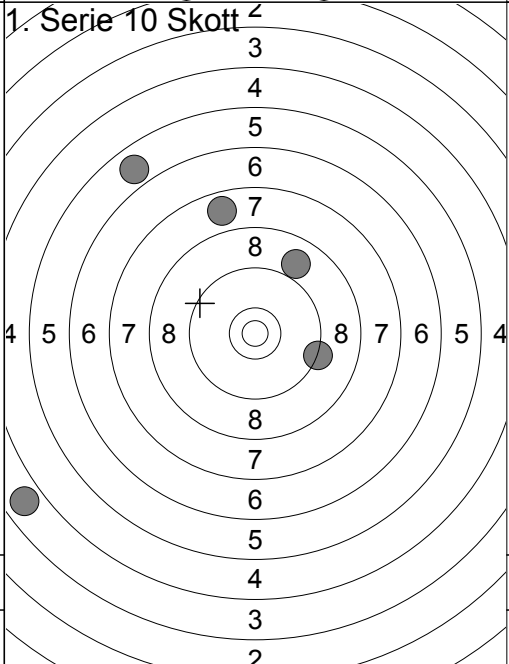

6:	8.9	↗
7:	7.8	↑
8:	3.8	↙
9:	5.9	↗
10:	9.3	→
Serie		32
Total		249

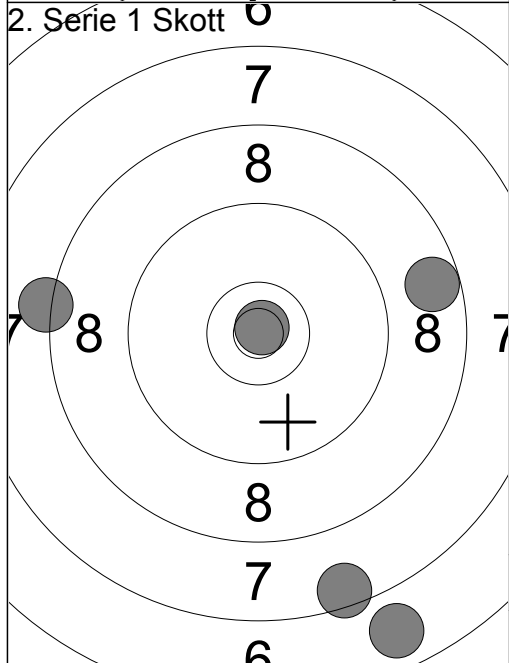

1:	8.2	←
2:	10.9x	↗
3:	7.5	↓
4:	8.7	→
5:	6.8	↓
Serie		39
Total		288



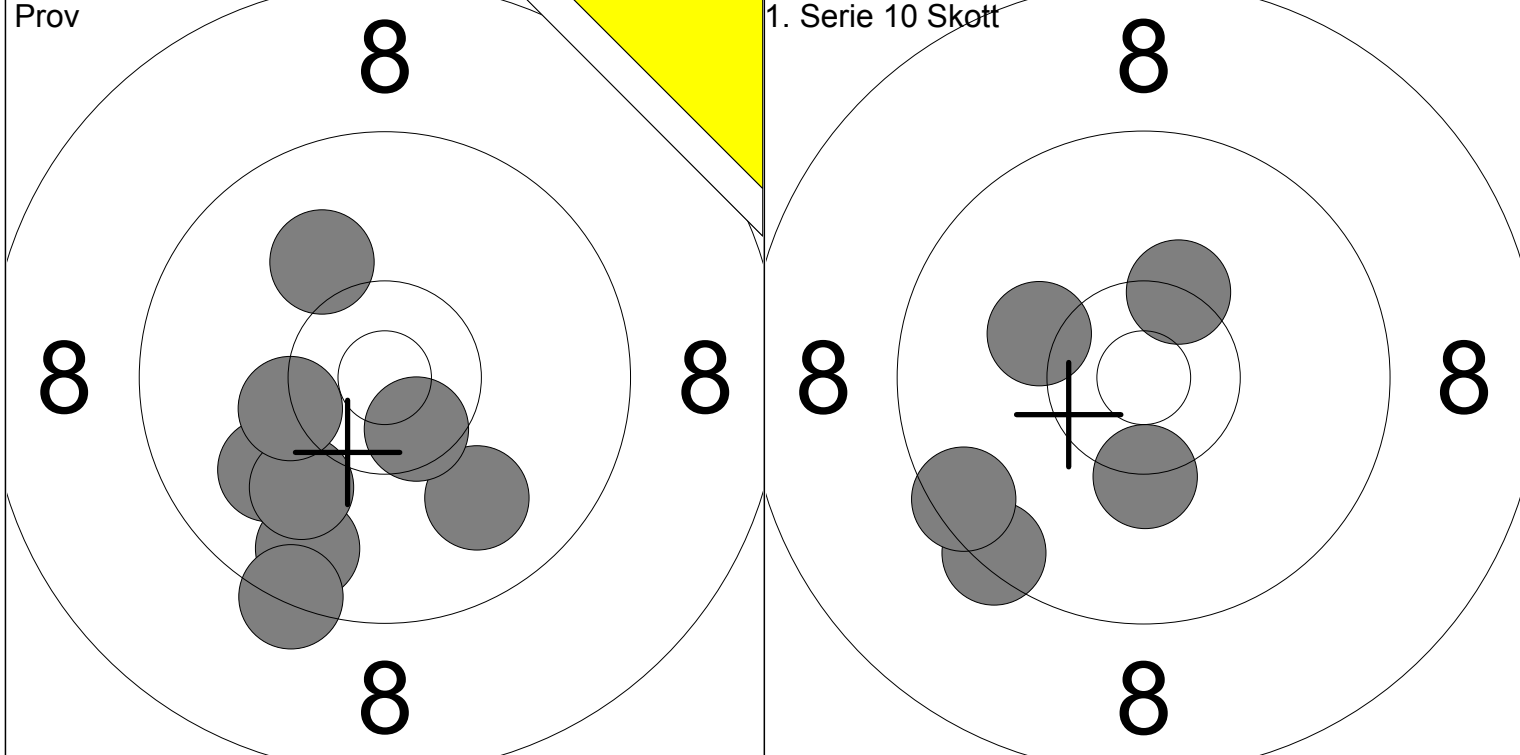

1: 9.9 ↘	6: 9.3 ↘			1: 10.3x ↗			
2: 10.1 ↗	7: 10.0 ↘	Serie	77	2: 9.4 ↘	Serie	48	
3: 9.7 ↘	8: 10.3 ←			3: 10.2 ←			
4: 10.0 ↙		Total	184	4: 10.3x ↓	Total	232	
5: 10.5x ↘				5: 9.5 ↙			

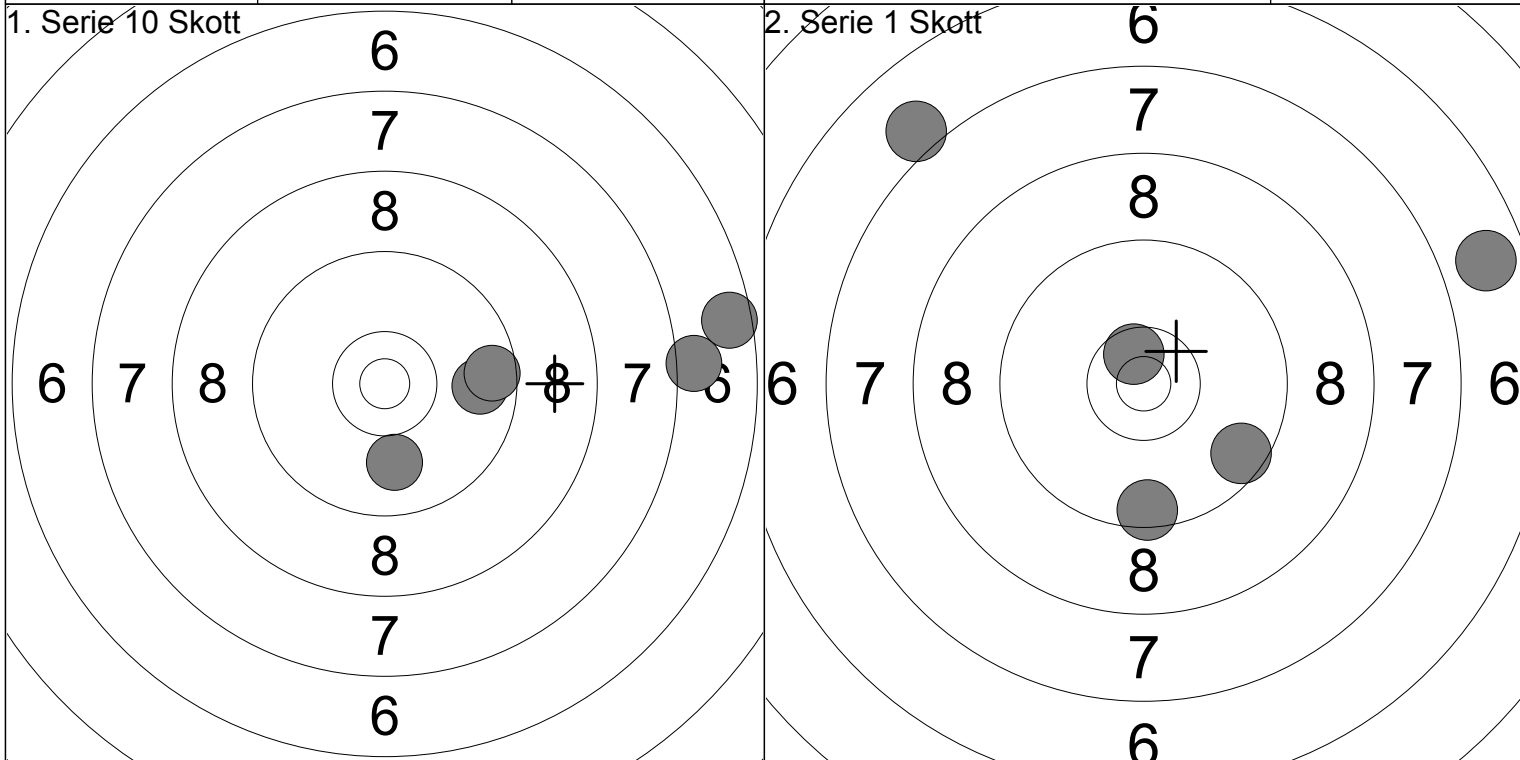

6: 7.1 →	1: 6.8 →			2: 9.5 ↓			
7: 6.6 →	2: 9.5 ↓	Serie	41	3: 7.0 ↗	Serie	41	
8: 9.8 →	3: 7.0 ↗			4: 9.6 ↘			
9: 10.0 ↓	4: 9.6 ↘	Total	273	5: 10.6x ↗	Total	314	
10: 9.6 →	5: 10.6x ↗						

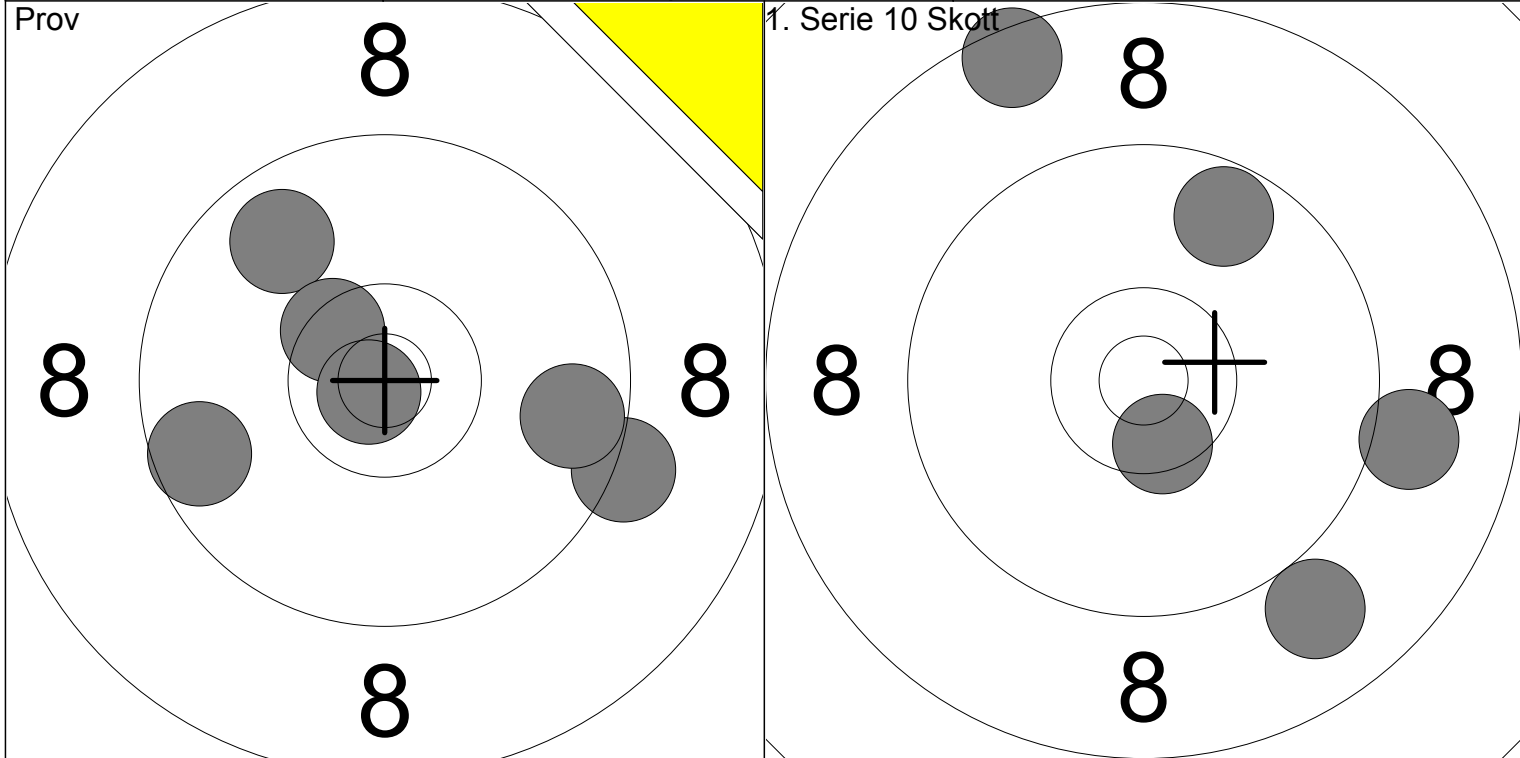

1: 9.8 ↗	6: 10.8x ↖	Serie	56	1: 9.0 ↘		Serie	45
2: 9.6 ↖				2: 8.5 ↗			
3: 10.5x ↗				3: 10.5x ↘			
4: 9.2 ↘		Total	175	4: 9.7 ↗		Total	220
5: 9.7 ↘				5: 9.0 ↘			

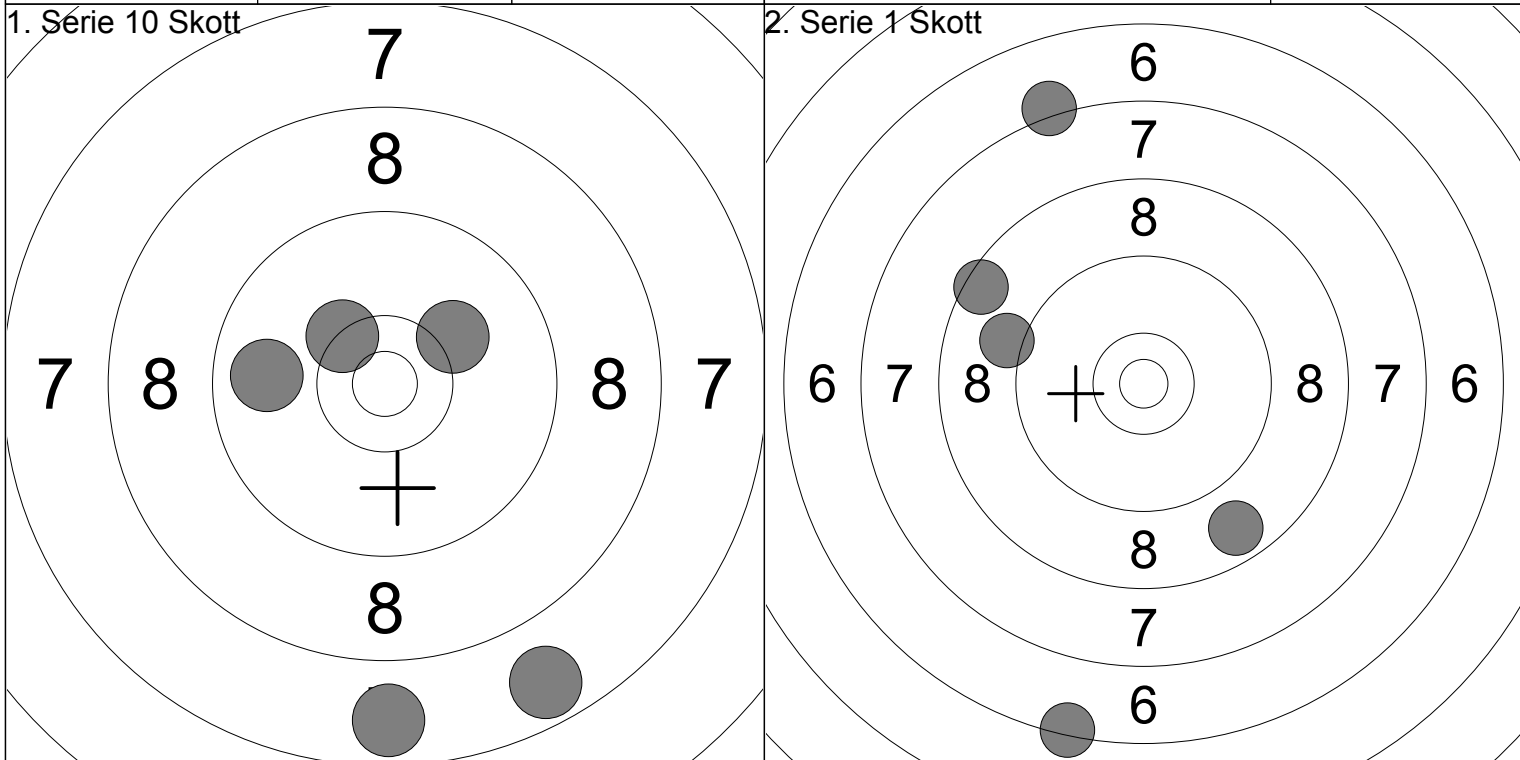

6: 9.8 ↖		Serie	43	1: 7.2 ↗		Serie	38
7: 10.2 ↗				2: 6.4 ↘			
8: 10.3x ↗				3: 8.7 ↘			
9: 7.7 ↘		Total	263	4: 9.1 ↗		Total	301
10: 7.7 ↘				5: 8.5 ↗			

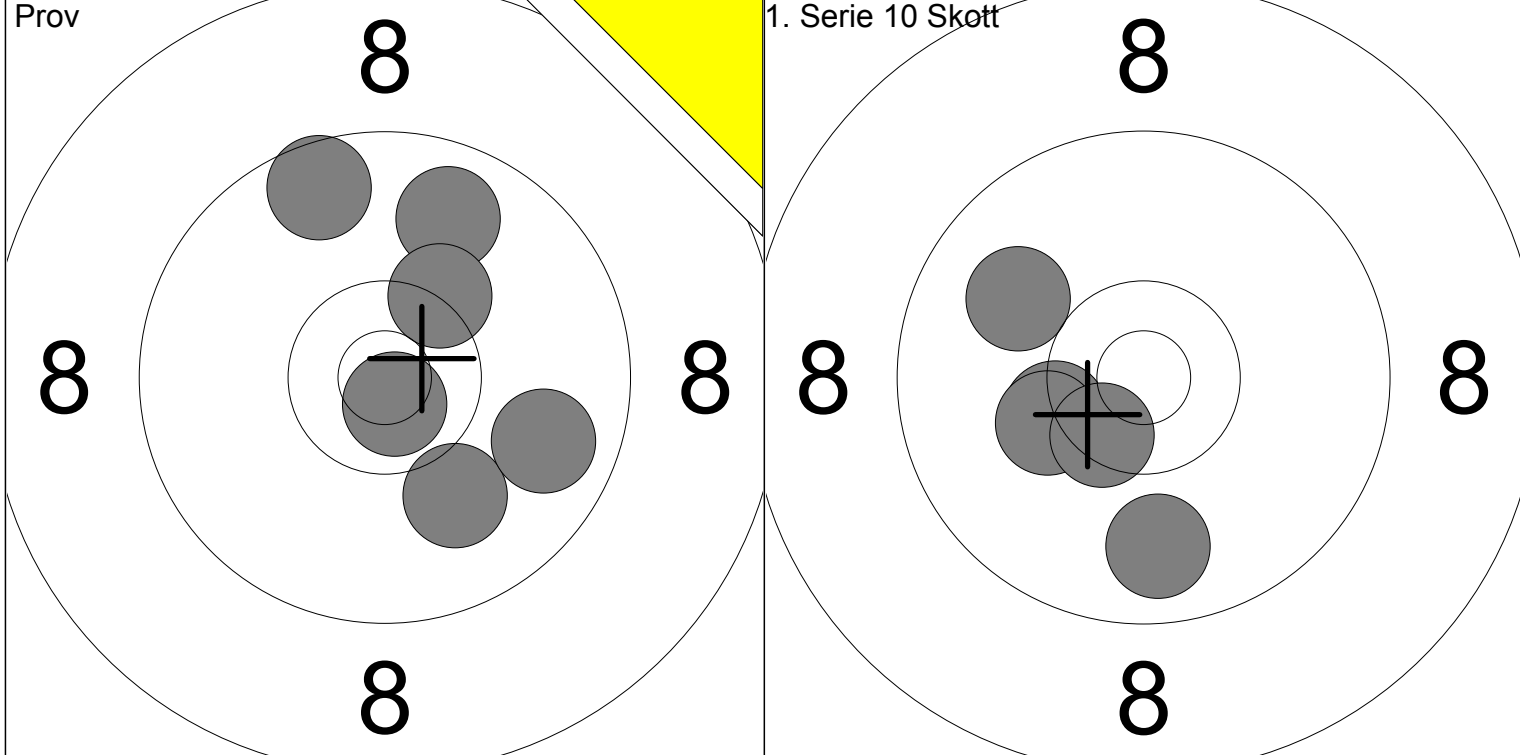

1: 9.6 ↗	6: 9.8 →			1: 10.3x ↙			
2: 9.8 ↗		Serie	57	2: 10.2 ↙		Serie	49
3: 10.0 ↘				3: 9.8 ↘			
4: 10.3x ↗		Total	173	4: 10.5x ↘		Total	222
5: 10.8x ↘				5: 10.0 ↙			

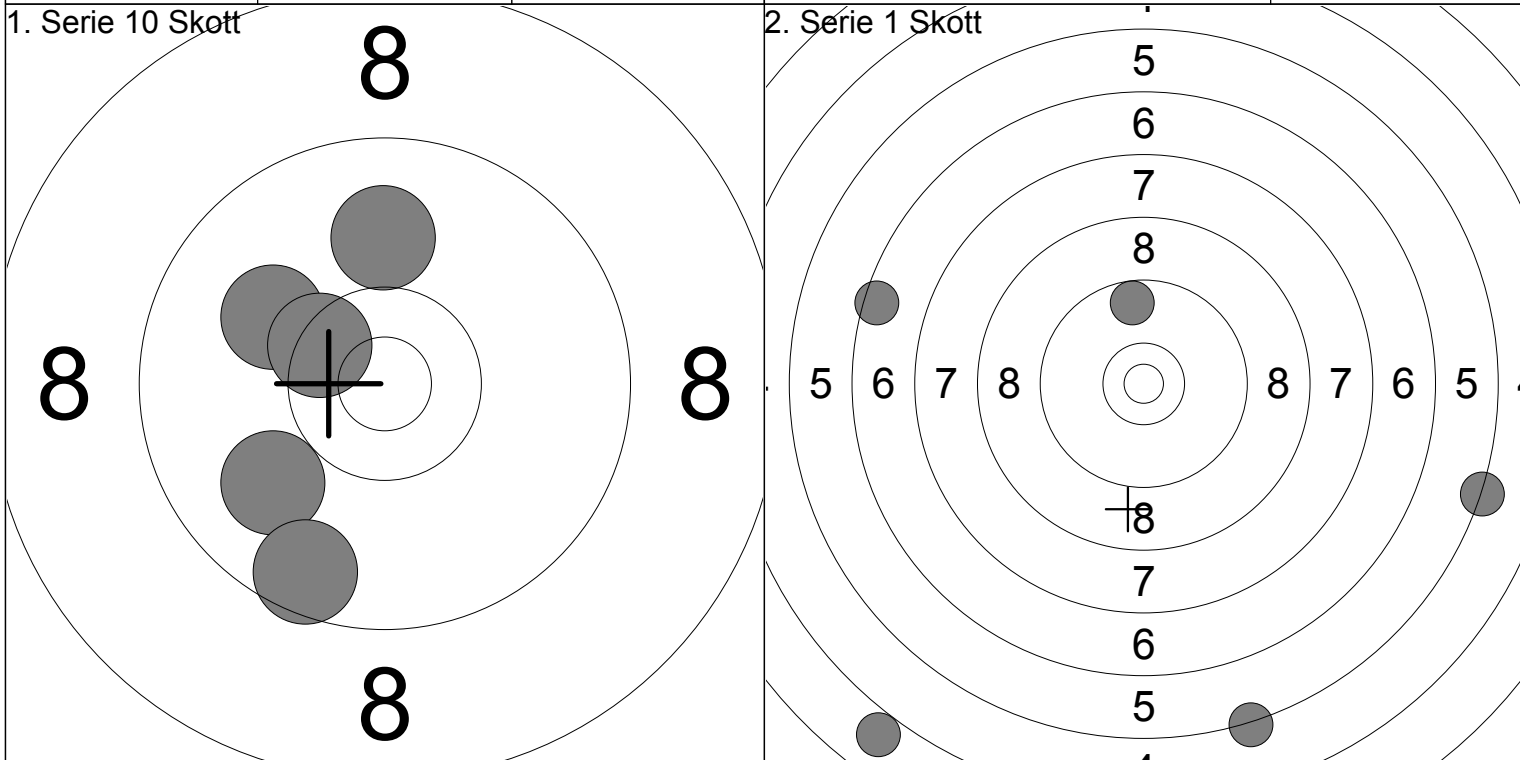

6: 10.1 ↙				1: 3.9 ↙			
7: 10.0 ↑		Serie	48	2: 6.5 ↙		Serie	28
8: 9.9 ↙				3: 5.3 ↘			
9: 10.4x ↙		Total	270	4: 5.3 →		Total	298
10: 9.6 ↘				5: 9.7 ↑			

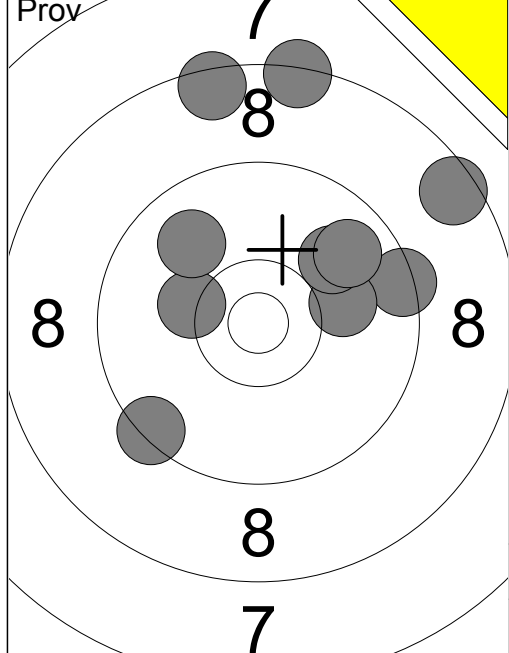

1:	9.4	→
2:	10.1	→
3:	10.0	↗
4:	10.2	←
5:	9.9	↖
6:	9.8	↗
7:	8.5	↑
8:	8.4	↑
9:	9.4	↙
10:	8.5	↗
Serie		90
Total		159

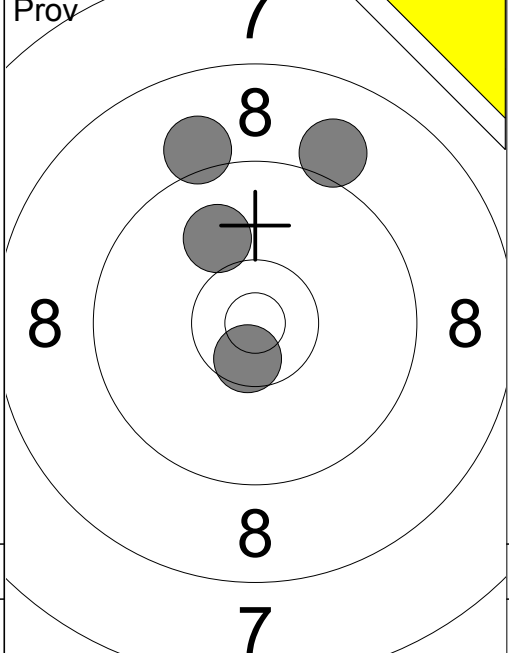

11:	10.0	↖
12:	9.1	↖
13:	10.6x	↘
14:	9.0	↗
Serie		38
Total		159

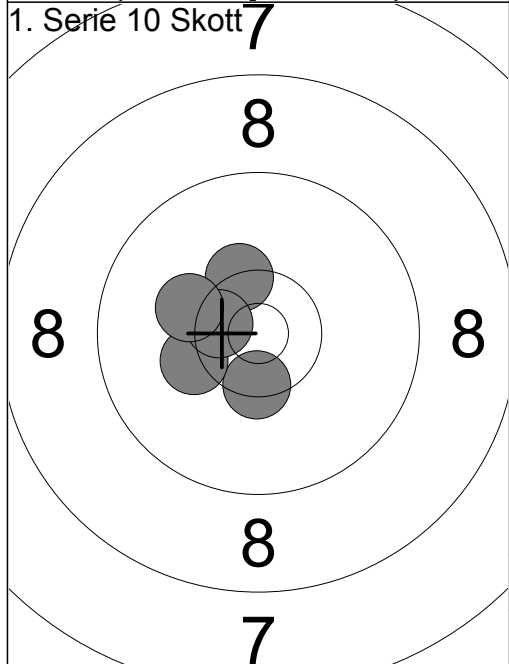

1:	10.4x	↘
2:	10.2	←
3:	10.3x	↖
4:	10.5x	←
5:	10.2	←
Serie		50
Total		209

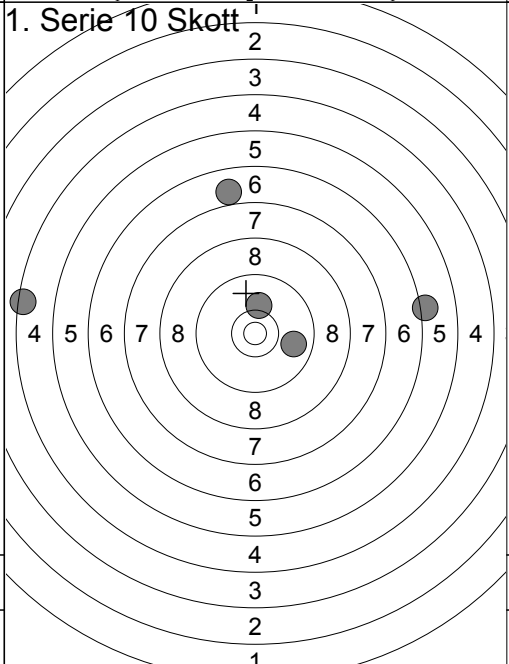

6:	10.2	↑
7:	9.8	→
8:	6.2	→
9:	4.4	←
10:	6.9	↑
Serie		35
Total		244

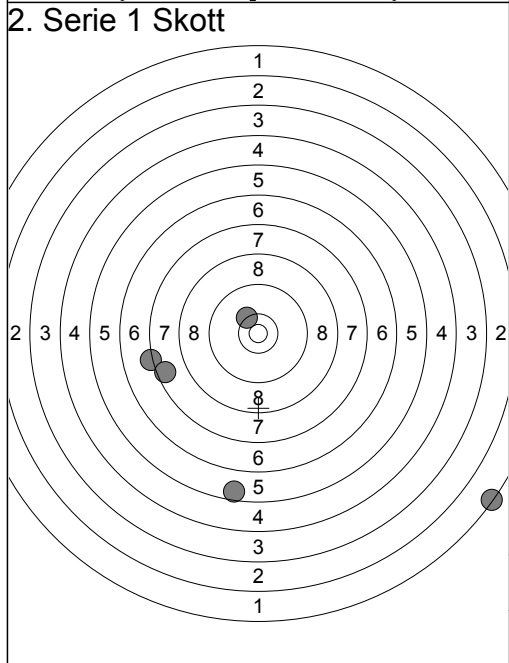

1:	7.2	←
2:	7.6	←
3:	5.6	↘
4:	10.3x	↖
5:	1.3	↘
Serie		30
Total		274

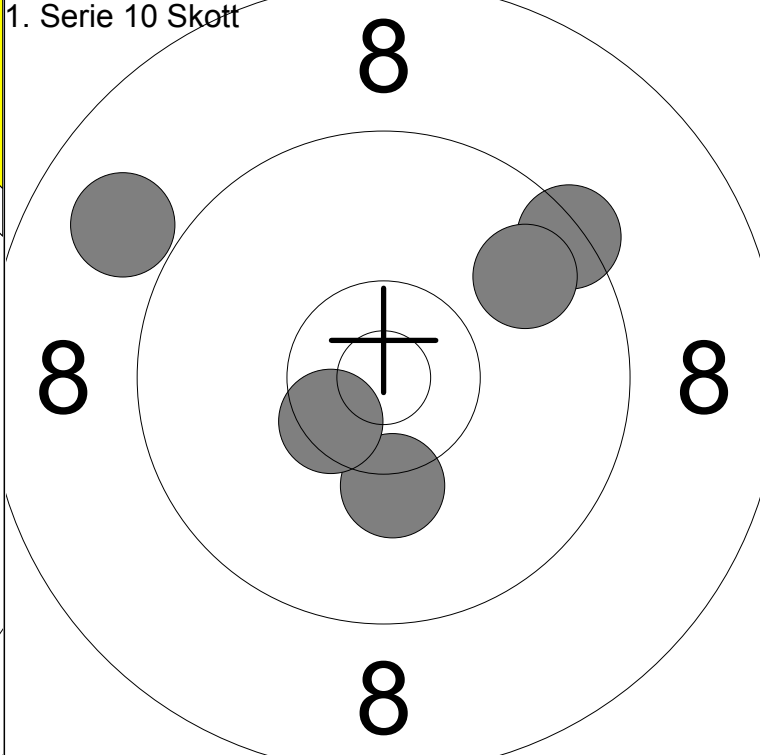
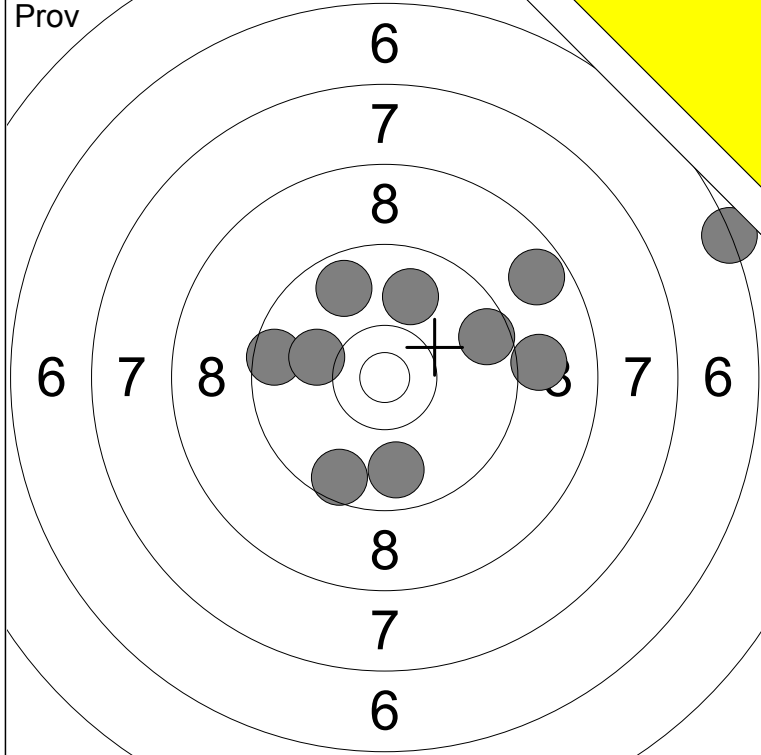

1: 8.7 ↗	6: 10.1 ←	Serie	87
2: 9.7 ↖	7: 9.8 ↓		
3: 9.6 ↘	8: 9.6 →	Total	185
4: 6.3 →	9: 9.9 ↑		
5: 9.6 ←	10: 9.0 →		

1: 8.9 ↖	Serie	46
2: 10.2 ↓		
3: 9.4 ↗	Total	231
4: 9.8 ↗		
5: 10.5x ↘		

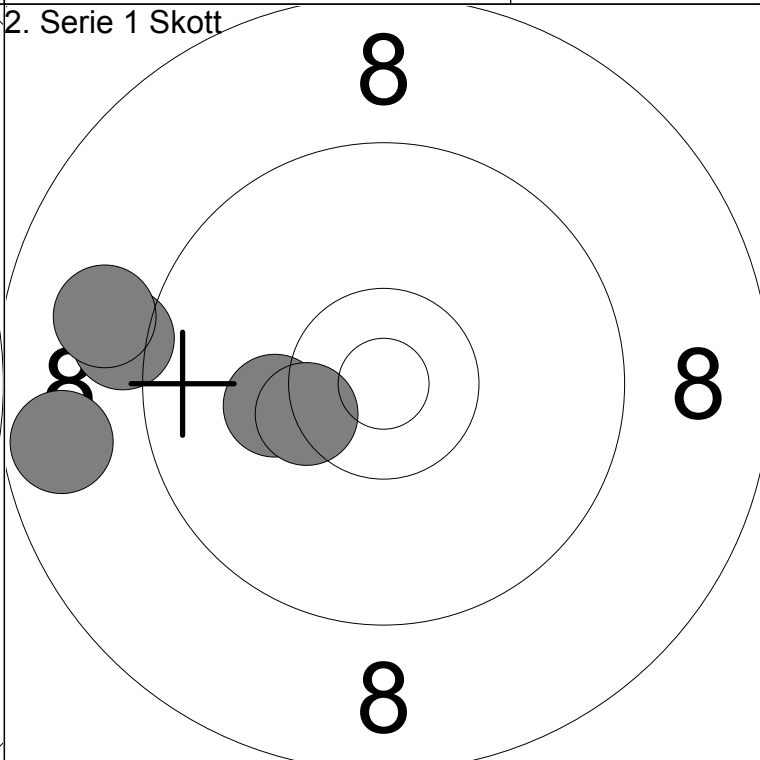
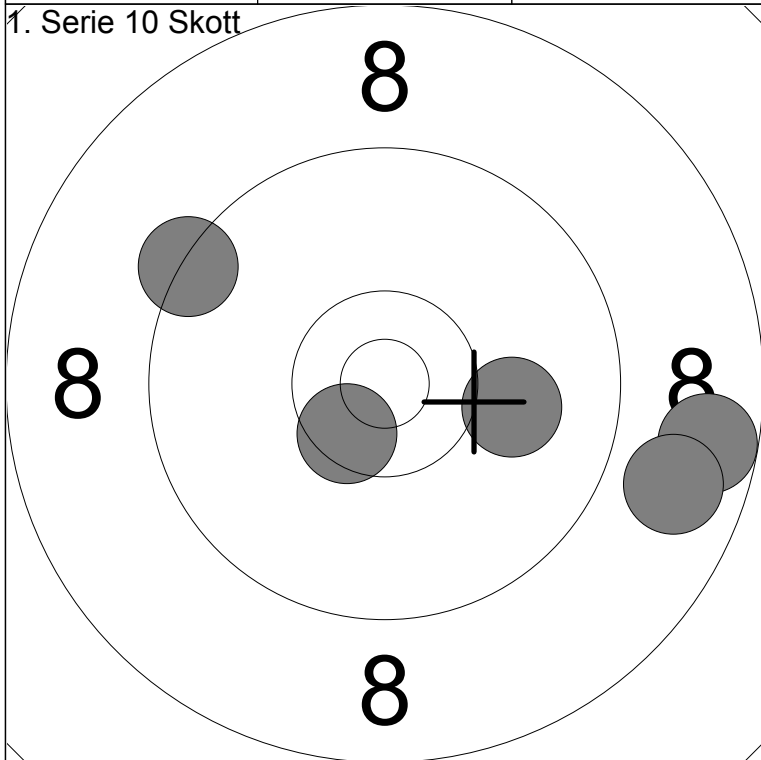

6: 8.7 →	Serie	45
7: 10.0 →		
8: 10.5x ↘	Total	276
9: 9.3 ↖		
10: 8.8 →		

1: 9.1 ←	Serie	46
2: 8.7 ←		
3: 9.0 ←	Total	322
4: 10.2 ←		
5: 10.4x ←		



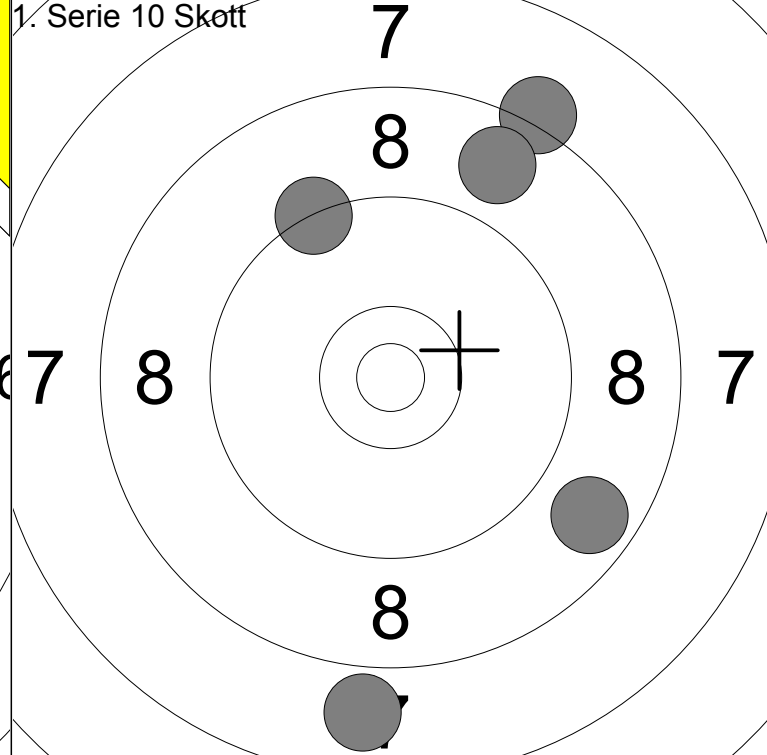
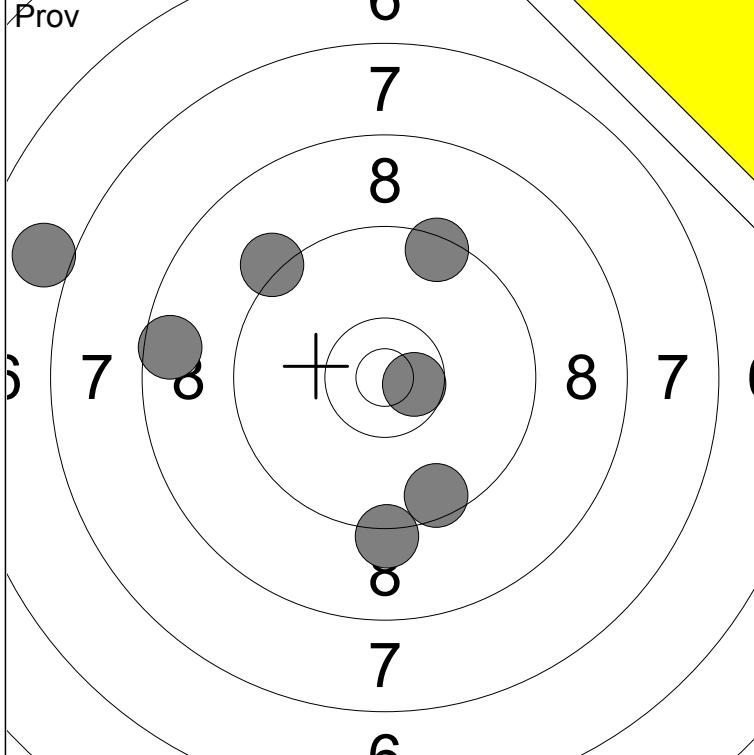

1: 9.2 ↓	6: 10.6x →	Serie	61
2: 8.6 ←	7: 9.2 ↗		
3: 7.0 ↖		Total	156
4: 9.5 ↓			
5: 9.4 ↗			

1: 8.2 ↗	Serie	40
2: 8.8 ↗		
3: 7.9 ↓	Total	196
4: 8.7 ↘		
5: 9.3 ↗		

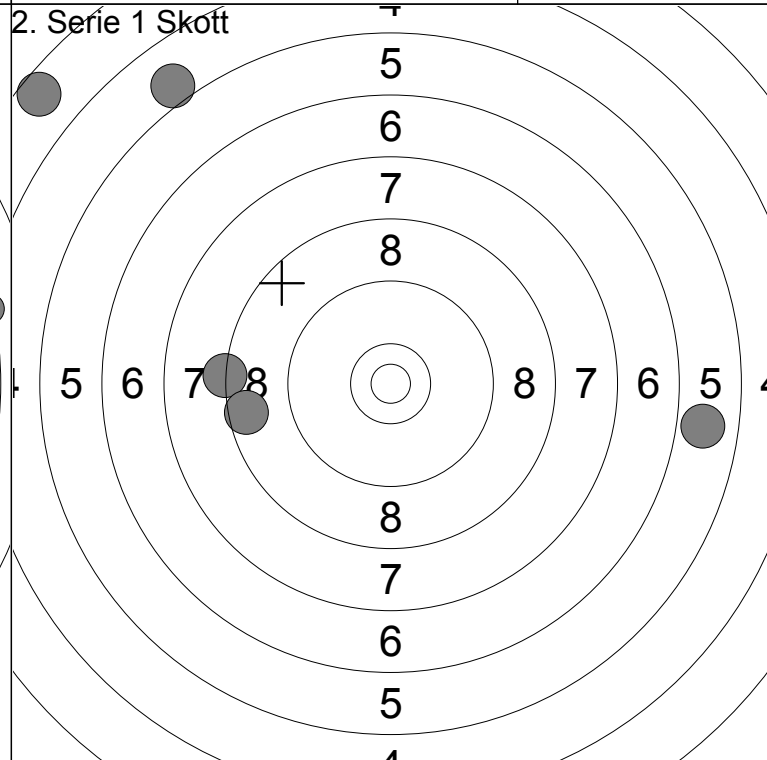
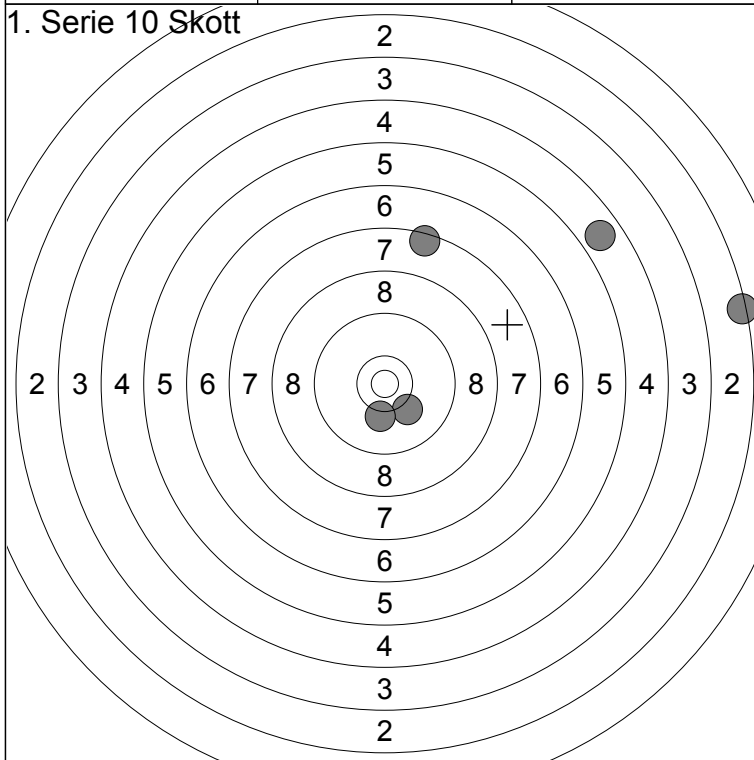

6: 4.8 ↗	Serie	33
7: 10.1 ↓		
8: 10.2 ↓	Total	229
9: 7.5 ↗		
10: 2.4 →		

1: 5.0 ↗	Serie	29
2: 8.3 ←		
3: 5.9 →	Total	258
4: 3.6 ↗		
5: 8.6 ←		