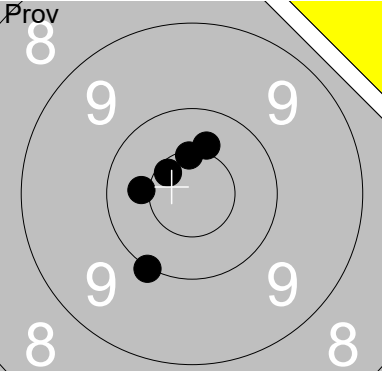
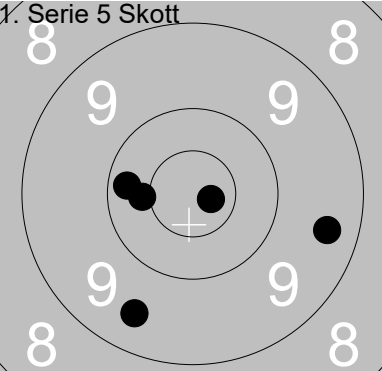
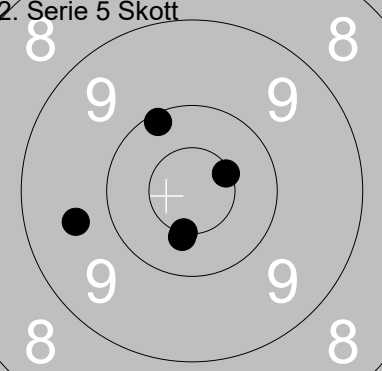
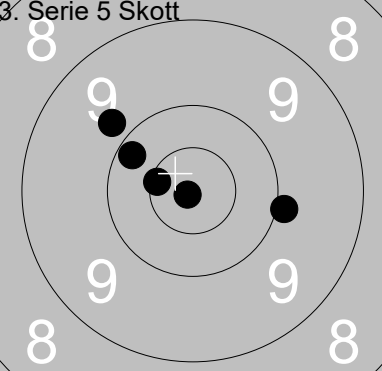
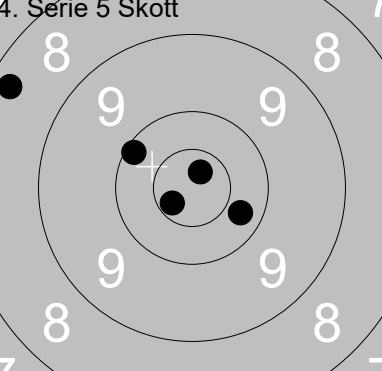
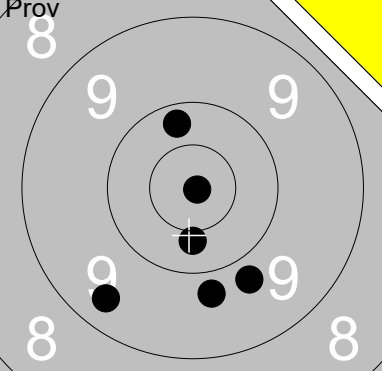
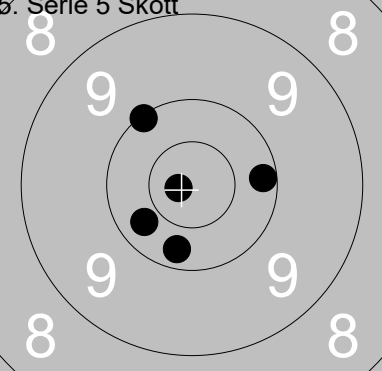
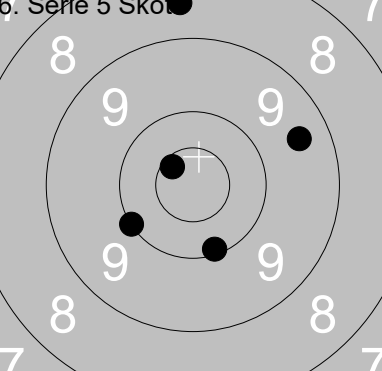
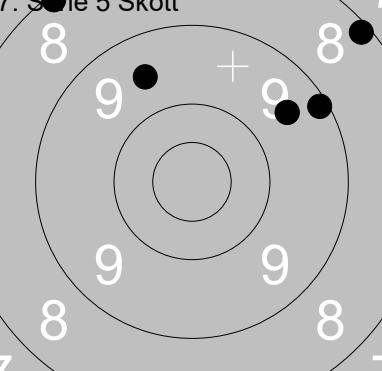
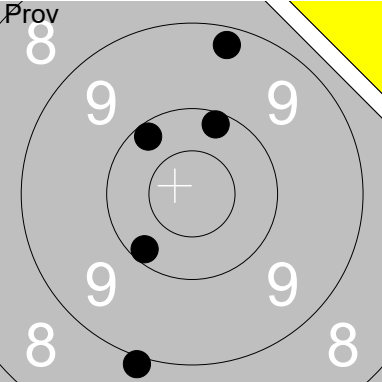
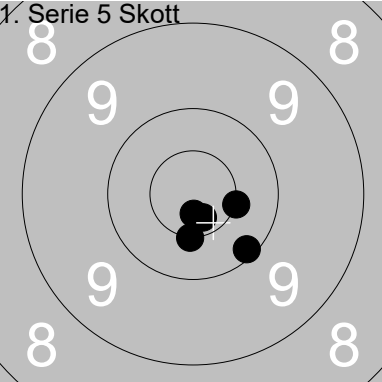
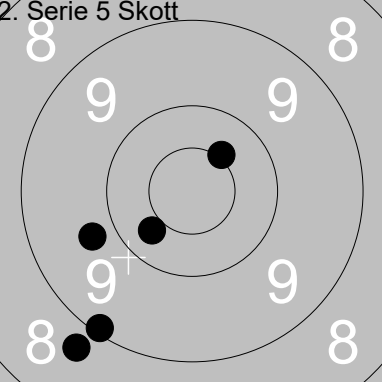
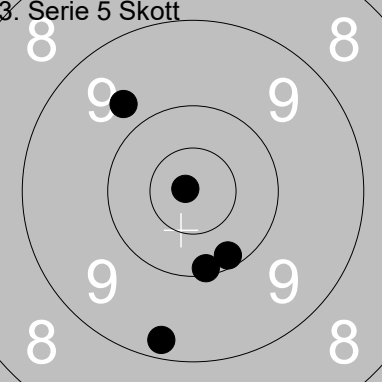
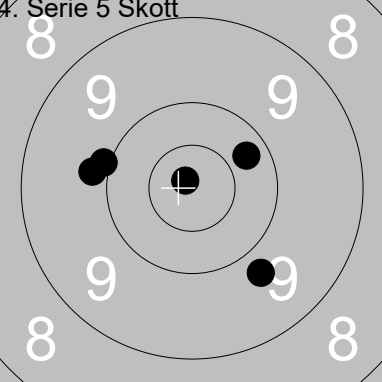
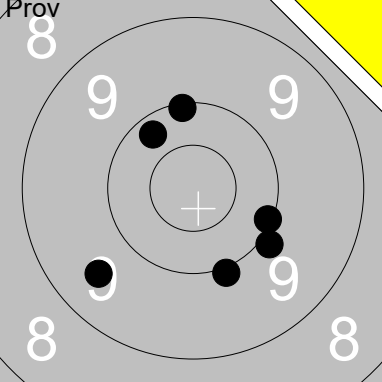
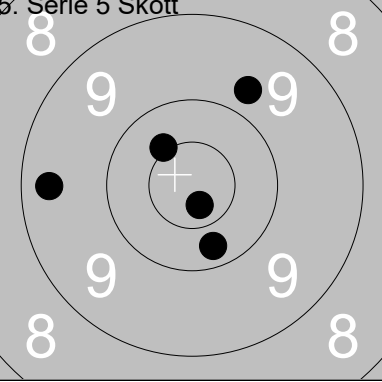
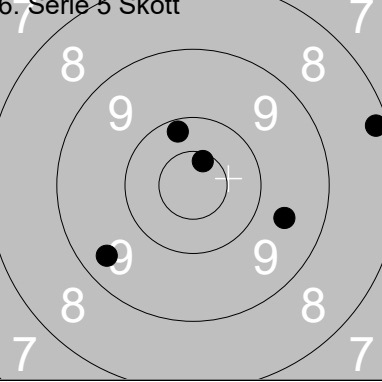
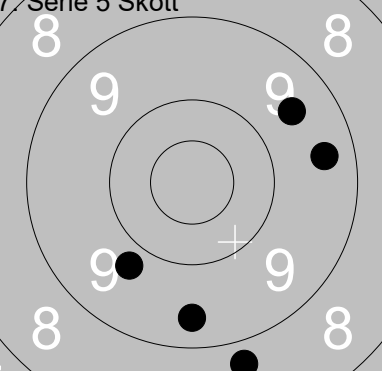
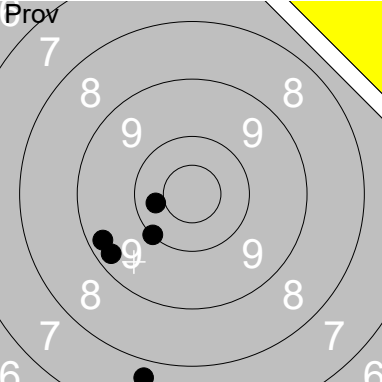
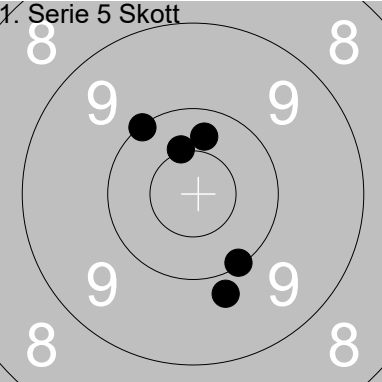
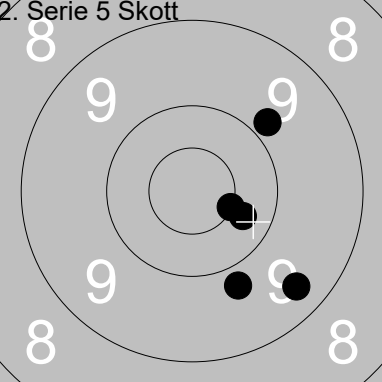
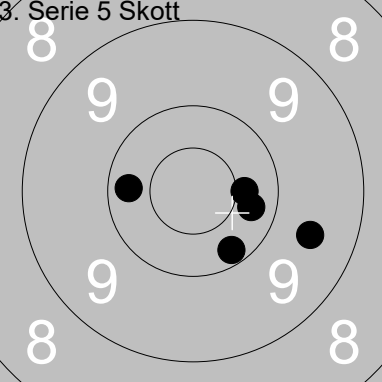
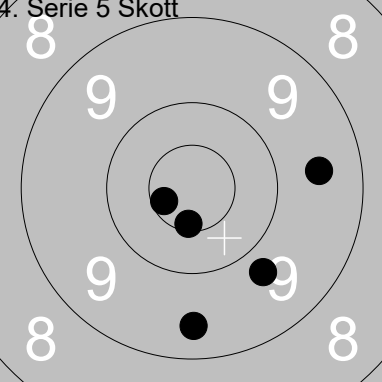
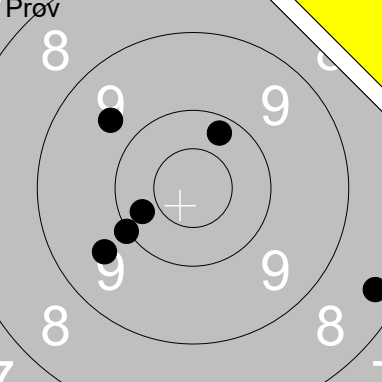
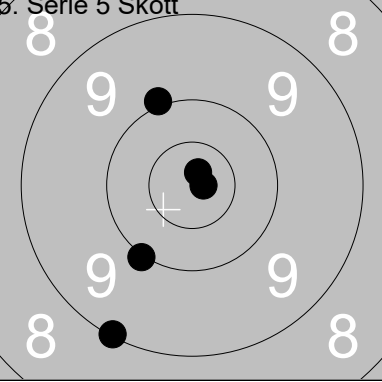
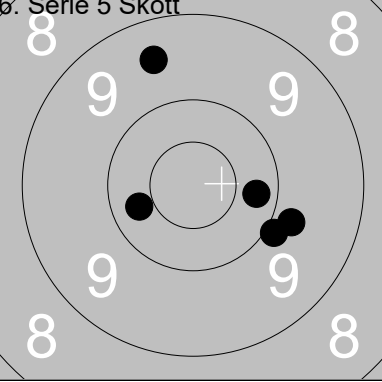
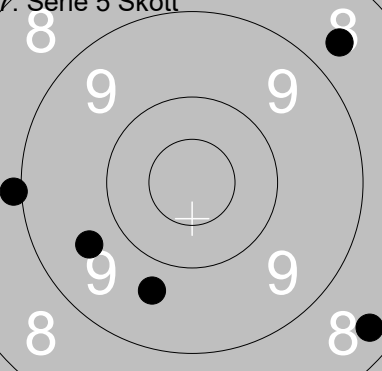

Skjutlag	Tavla	Casper Fredriksson					
1	1	Ramselefors	Ramselefors	B	Vb		
07.07.2019		Tavelträffen 2019	Ramselefors SKF				
	1: 10.4 ↑ 2: 10.5x ↑ 3: 10.4 ← 4: 10.0 ↓ 5: 10.6x ↗	1. Serie 5 Skott 	1: 10.7x → 2: 9.5 ↓ 3: 10.2 ← 4: 10.4 ← 5: 9.4 →	Serie	50	Serie	48
	Total	0	Total	48			
2. Serie 5 Skott 	1: 10.4x ↓ 2: 9.6 ← 3: 10.5x ↓ 4: 10.5x → 5: 10.1 ↗	3. Serie 5 Skott 	1: 10.2 ↗ 2: 9.8 ↗ 3: 10.9x ← 4: 10.6x ← 5: 9.9 →	Serie	49	Serie	48
	Total	97	Total	145			
4. Serie 5 Skott 	1: 8.3 ← 2: 10.1 ↗ 3: 10.3 → 4: 10.7x ↑ 5: 10.7x ←	Prov 	1: 10.9x → 2: 9.8 ↓ 3: 10.2 ↑ 4: 9.8 ↓ 5: 9.4 ↘ 6: 10.4 ↓	Serie	48	Serie	57
	Total	193	Total	193			
5. Serie 5 Skott 	1: 10.1 ↗ 2: 10.8x ← 3: 10.2 → 4: 10.2 ↓ 5: 10.3 ←	6. Serie 5 Skott 	1: 8.5 ↑ 2: 10.1 ↓ 3: 10.6x ↗ 4: 10.0 ← 5: 9.4 →	Serie	50	Serie	47
	Total	243	Total	290			
7. Serie 5 Skott 	1: 9.5 → 2: 9.6 ↗ 3: 9.1 → 4: 8.1 ↗ 5: 8.1 ↗			Serie	43		
	Total	333					

Skjutlag	Tavla	Erik Westling	
1	2		
Ramselefors	Bollnäs	C	Gä
07.07.2019	Tavelträffen 2019	Ramselefors SKF	
	1: 10.3 ↑ 2: 10.1 → 3: 9.9 ↘ 4: 9.1 ↓ 5: 10.5x ←		1: 9.9 → 2: 10.6x ← 3: 9.5 ↗ 4: 10.2 → 5: 9.7 ↓
Serie 48	Total 0	Serie 47	Total 47
	1: 9.2 ↑ 2: 8.7 ↑ 3: 9.6 ↖ 4: 9.6 ↓ 5: 9.7 ↓		1: 9.8 ↗ 2: 10.5x ↗ 3: 10.4 ↓ 4: 10.1 ↓ 5: 10.8x ↖
Serie 44	Total 91	Serie 49	Total 140
	1: 10.2 ↗ 2: 10.3 ↓ 3: 10.3 ↑ 4: 10.0 ↗ 5: 10.0 ↓		1: 8.5 ↓ 2: 9.3 ↓ 3: 9.9 → 4: 9.8 ↓ 5: 10.4x ↑ 6: 8.5 ←
Serie 50	Total 190	Serie 53	Total 190
	1: 9.2 ↘ 2: 9.1 ↓ 3: 10.3 ↓ 4: 9.2 ↑ 5: 9.7 ←		1: 8.1 ← 2: 6.7 ↓ 3: 9.1 ← 4: 9.5 ↓ 5: 10.2 ↓
Serie 46	Total 236	Serie 42	Total 278
	1: 8.0 ↓ 2: 9.8 ↓ 3: 10.2 ↑ 4: 9.1 ← 5: 8.2 ↖		
Serie 44	Total 322		

Skjutlag	Tavla	Harry Östling		C	No
1	3	Ramselefors	F 21		
07.07.2019	Tavelträffen 2019	Ramselefors SKF			
Prov 	1: 9.2 ↑ 2: 10.2 ↖ 3: 10.2 ↑ 4: 10.2 ↙ 5: 8.9 ↓ Serie 47 Total 0	1. Serie 5 Skott 	1: 10.7x ↓ 2: 10.1 ↙ 3: 10.5x → 4: 10.5x ↓ 5: 10.7x ↓ Serie 50 Total 50		
2. Serie 5 Skott 	1: 10.4x ↗ 2: 9.7 ← 3: 9.1 ↙ 4: 10.3 ↙ 5: 8.8 ↙ Serie 46 Total 96	3. Serie 5 Skott 	1: 9.2 ↓ 2: 10.9x ↖ 3: 10.2 ↙ 4: 9.7 ↗ 5: 10.1 ↓ Serie 48 Total 144		
4. Serie 5 Skott 	1: 10.0 ← 2: 9.8 ← 3: 10.3 → 4: 9.8 ↙ 5: 10.8x ↗ Serie 48 Total 192	Prov 	1: 10.0 ↓ 2: 10.1 ↑ 3: 10.2 ↗ 4: 9.9 ↙ 5: 10.1 → 6: 9.5 ↙ Serie 58 Total 192		
5. Serie 5 Skott 	1: 9.7 ↗ 2: 9.4 ← 3: 10.3 ↙ 4: 10.4x ↗ 5: 10.7x ↙ Serie 48 Total 240	6. Serie 5 Skott 	1: 8.2 → 2: 10.2 ↑ 3: 9.6 → 4: 9.4 ↙ 5: 10.6x ↑ Serie 46 Total 286		
7. Serie 5 Skott 	1: 9.4 ↓ 2: 9.5 ↗ 3: 9.8 ↙ 4: 8.7 ↙ 5: 9.4 → Serie 44 Total 330				

Skjutlag	Tavla	Henry Lindström	
1	4		
Ramselefors	I 19 / A 9	C	No
07.07.2019	Tavelträffen 2019	Ramselefors SKF	
Prov		1. Serie 5 Skott	
	1: 7.7 ↓ 2: 9.3 ↙ 3: 9.3 ↙ 4: 10.3 ← 5: 10.0 ↙		1: 10.1 ↓ 2: 10.4x ↑ 3: 10.3 ↑ 4: 9.8 ↓ 5: 10.0 ↗
	Serie 45 Total 0		Serie 49 Total 49
2. Serie 5 Skott		3. Serie 5 Skott	
	1: 9.8 ↓ 2: 9.4 ↘ 3: 10.3 ↘ 4: 9.8 ↗ 5: 10.5x ↘		1: 10.4 → 2: 9.6 ↘ 3: 10.2 ↘ 4: 10.3 → 5: 10.3 ←
	Serie 47 Total 96		Serie 49 Total 145
4. Serie 5 Skott		Prov	
	1: 10.6x ← 2: 9.5 → 3: 9.7 ↘ 4: 10.6x ↓ 5: 9.4 ↓		1: 9.7 ↖ 2: 10.0 ↙ 3: 10.3 ↙ 4: 9.6 ↙ 5: 8.4 ↘ 6: 10.2 ↗
	Serie 47 Total 192		Serie 56 Total 192
5. Serie 5 Skott		6. Serie 5 Skott	
	1: 10.0 ↖ 2: 10.8x → 3: 9.1 ↓ 4: 10.8x ↗ 5: 10.0 ↙		1: 9.9 ↘ 2: 9.5 ↖ 3: 10.3 → 4: 9.8 → 5: 10.3 ←
	Serie 49 Total 241		Serie 47 Total 288
7. Serie 5 Skott			
	1: 8.7 ↗ 2: 9.7 ↓ 3: 8.3 ↘ 4: 8.9 ← 5: 9.6 ↙		
	Serie 42 Total 330		

Skjuttag	Tavla	Håkan Eriksson	
1	5		
Ramselefors	Nedre Ullerud	C	Vä
07.07.2019	Tavelträffen 2019	Ramselefors SKF	
	1: 9.4 ↘ 2: 9.8 ↘ 3: 9.8 ↘ 4: 10.5x ← 5: 10.1 ↘	1. Serie 5 Skott 	1: 10.6x ↗ 2: 10.3 ↘ 3: 9.3 ↘ 4: 9.4 ↘ 5: 9.1 ↘
	Serie 47	Serie 47	Total 47
	Total 0	Total 47	Total 47
	1: 8.6 ↗ 2: 10.0 ↘ 3: 10.6x ↘ 4: 10.3 ↘ 5: 9.7 ↘	3. Serie 5 Skott 	1: 9.8 ↗ 2: 10.0 ↘ 3: 9.5 ← 4: 9.9 ↘ 5: 8.0 ↘
	Serie 47	Serie 45	Total 139
	Total 94	Total 139	Total 139
	1: 8.6 ↗ 2: 8.9 ↗ 3: 10.8x ↘ 4: 10.3 ↘ 5: 10.6x ↘		1: 9.7 ↗ 2: 9.5 ↗ 3: 10.7x ↘ 4: 10.4 ↘ 5: 9.8 ↘ 6: 9.2 ↗
	Serie 46	Serie 56	Total 185
	Total 185	Total 185	Total 185
	1: 9.8 ↗ 2: 10.1 ↗ 3: 9.0 ← 4: 10.8x ↘ 5: 10.4x ↗	6. Serie 5 Skott 	1: 3.2 ↘ 2: 9.0 → 3: 8.3 ↘ 4: 8.4 → 5: 9.3 ↗
	Serie 48	Serie 37	Total 270
	Total 233	Total 270	Total 270
	1: 8.8 → 2: 7.9 ↘ 3: 9.5 ↘ 4: 10.7x ← 5: 9.1 ←		
	Serie 43		
	Total 313		

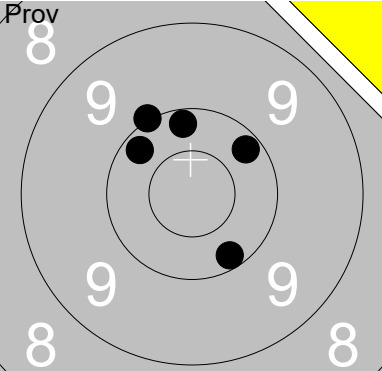
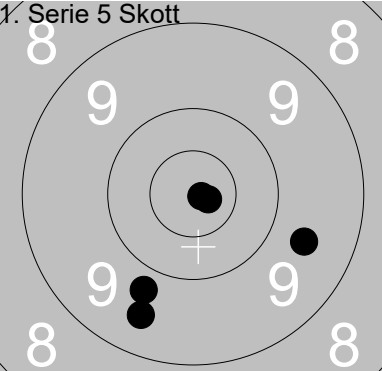
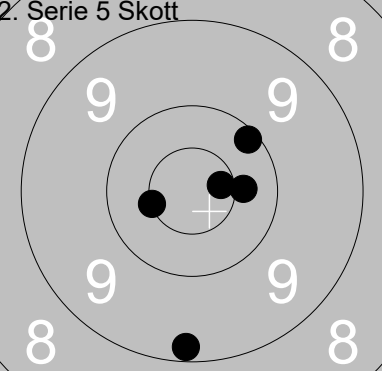
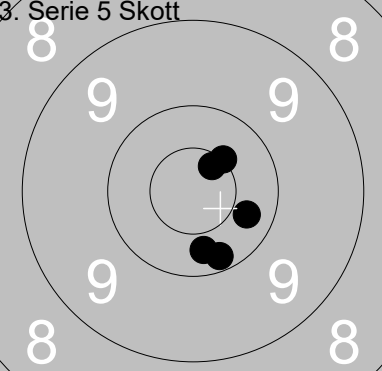
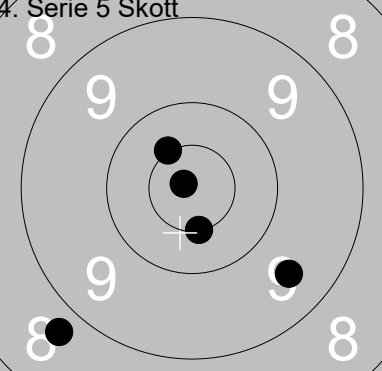
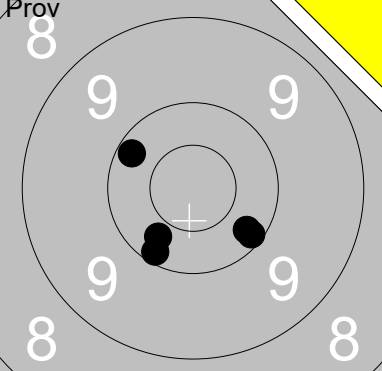
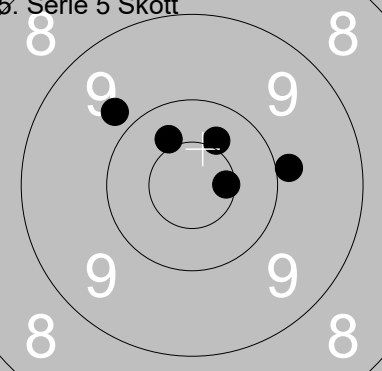
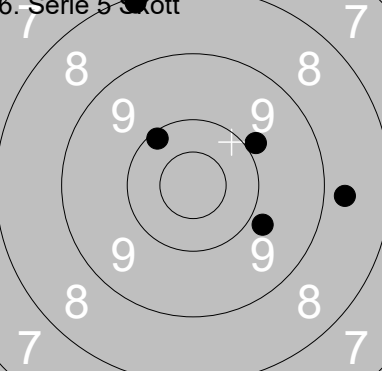
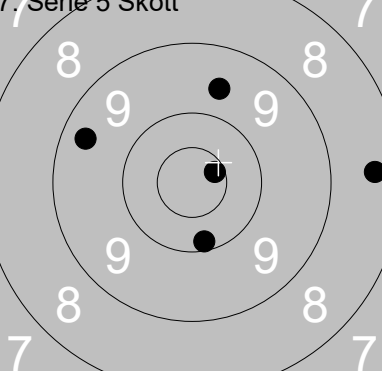
Skjutlag	Tavla	Håkan Lidman	
1	6		
Ramselefors	Piteå	C	No
07.07.2019	Tavelträffen 2019	Ramselefors SKF	
	1: 10.2 ↗ 2: 10.0 ↗ 3: 10.2 ↗ 4: 10.2 ↑ 5: 10.2 ↓		1: 9.8 ↓ 2: 9.5 ↓ 3: 9.6 → 4: 10.8x → 5: 10.9x →
	Serie 50		Serie 47
	Total 0		Total 47
	1: 10.5x ← 2: 9.2 ↓ 3: 10.6x → 4: 10.4 → 5: 10.1 ↗		1: 10.6x ↗ 2: 10.2 ↓ 3: 10.3 ↓ 4: 10.5x ↗ 5: 10.3 →
	Serie 49		Serie 50
	Total 96		Total 146
	1: 8.7 ↓ 2: 10.8x ↗ 3: 9.5 ↓ 4: 10.5x ↗ 5: 10.5x ↓		1: 10.1 ↓ 2: 10.1 ↓ 3: 10.2 ↗ 4: 10.3 ↓ 5: 10.2 ↓
	Serie 47		Serie 50
	Total 193		Total 193
	1: 9.8 ↗ 2: 10.4 ↗ 3: 10.6x → 4: 10.4 ↗ 5: 9.9 →		1: 9.8 ↓ 2: 10.1 ↗ 3: 8.1 ↗ 4: 9.9 ↗ 5: 8.7 →
	Serie 48		Serie 44
	Total 241		Total 285
	1: 9.6 ↑ 2: 10.6x → 3: 8.4 → 4: 9.4 ↗ 5: 10.2 ↓		
	Serie 46		
	Total 331		

Skjutlag	Tavla	Jan-Erik Fäldt	
1	7		
Ramselefors	Storfors	C	Vä
07.07.2019	Tavelträffen 2019	Ramselefors SKF	
Prov 	1: 9.1 ↙ 2: 10.3 ↑ 3: 9.2 ↓ 4: 10.7x ↓ 5: 9.8 ↓	1. Serie 5 Skott 	1: 10.0 ↑ 2: 10.2 ↙ 3: 10.4x ↑ 4: 10.2 ↙ 5: 10.3 →
Serie 47	Total 0	Serie 50	Total 50
2. Serie 5 Skott 	1: 9.2 ↗ 2: 10.5x → 3: 9.8 → 4: 10.0 ↗ 5: 9.8 ↙	3. Serie 5 Skott 	1: 10.9x ↙ 2: 10.6x ↙ 3: 9.7 ↓ 4: 9.6 ↙ 5: 10.7x ↑
Serie 47	Total 97	Serie 48	Total 145
4. Serie 5 Skott 	1: 10.2 ↗ 2: 10.4 ↓ 3: 9.9 ↓ 4: 10.4 ↗ 5: 10.4 ↙	Prov 	1: 10.7x ↑ 2: 9.5 ↑ 3: 9.9 ↑ 4: 10.2 ↓ 5: 9.6 ↑ 6: 9.6 →
Serie 49	Total 194	Serie 56	Total 194
5. Serie 5 Skott 	1: 10.3 ↙ 2: 9.9 ↙ 3: 10.0 ↙ 4: 9.7 ↙ 5: 9.2 ↓	6. Serie 5 Skott 	1: 9.0 ↗ 2: 10.7x ↓ 3: 9.4 ↗ 4: 7.3 ↑ 5: 10.3 ↙
Serie 47	Total 241	Serie 45	Total 286
7. Serie 5 Skott 	1: 9.5 ↑ 2: 0.0 3: 9.1 ↗ 4: 7.8 ↓ 5: 9.8 ↙		
Serie 34	Total 320		

Skjutlag	Tavla	Jan-Erik Karlsson	
1	8	Ramselefors	Ramselefors
07.07.2019		Tavelträffen 2019	Ramselefors SKF
	1: 10.1 → 2: 9.9 ↘ 3: 10.7x → 4: 9.4 ↗ 5: 9.7 ←	1. Serie 5 Skott 	1: 9.5 → 2: 10.1 → 3: 10.2 ↗ 4: 10.7x ↘ 5: 10.3 →
Serie 47		Serie 49	
Total 0		Total 49	
	1: 9.9 ↑ 2: 10.1 ← 3: 10.2 ↗ 4: 8.9 ↘ 5: 9.7 ↘	3. Serie 5 Skott 	1: 10.0 ↘ 2: 10.0 ↘ 3: 9.3 ← 4: 9.1 ← 5: 10.6x ↑
Serie 46		Serie 48	
Total 95		Total 143	
	1: 9.6 ↗ 2: 9.0 ↗ 3: 9.3 ↘ 4: 9.9 ↘ 5: 10.6x ↘		1: 9.4 ↑ 2: 9.3 ↗ 3: 9.4 ↑ 4: 10.0 ↗ 5: 7.9 ↗ 6: 9.0 ↗
Serie 46		Serie 53	
Total 189		Total 189	
	1: 10.5x → 2: 9.5 ↑ 3: 9.0 ← 4: 10.7x ↑ 5: 8.0 ↓	6. Serie 5 Skott 	1: 10.2 ↗ 2: 7.9 ↗ 3: 8.9 ↗ 4: 7.8 ← 5: 9.1 ↗
Serie 46		Serie 41	
Total 235		Total 276	
	1: 8.8 ↑ 2: 8.5 ↑ 3: 9.8 ↗ 4: 10.2 ↗ 5: 9.1 ↘		
Serie 44			
Total 320			

Skjutlag	Tavla	Jan-Olof Lampinen	
1	9		
Ramselefors	S 3	C	No
07.07.2019	Tavelträffen 2019	Ramselefors SKF	
Prov 	1: 8.8 ↗ 2: 9.9 ← 3: 10.2 ↘ 4: 10.0 ← 5: 10.0 ↗	1. Serie 5 Skott 	1: 10.3 → 2: 9.4 → 3: 10.5x ↗ 4: 10.4x ↑ 5: 10.1 ↘
Serie 47	Total 0	Serie 49	Total 49
2. Serie 5 Skott 	1: 9.2 ← 2: 10.3 → 3: 10.0 → 4: 10.1 ← 5: 10.6x ↗	3. Serie 5 Skott 	1: 10.6x ← 2: 10.2 ↘ 3: 10.8x ↘ 4: 10.3 ← 5: 10.4 ←
Serie 49	Total 98	Serie 50	Total 148
4. Serie 5 Skott 	1: 10.6x ← 2: 10.4 ↘ 3: 9.7 ↘ 4: 10.0 ↘ 5: 9.8 ←	Prov 	1: 10.6x ↘ 2: 9.6 → 3: 9.4 ↘ 4: 10.2 ← 5: 8.8 → 6: 8.7 →
Serie 48	Total 196	Serie 54	Total 196
5. Serie 5 Skott 	1: 10.1 ↑ 2: 9.7 → 3: 10.2 ↗ 4: 10.7x ↗ 5: 10.1 ↗	6. Serie 5 Skott 	1: 7.7 → 2: 10.4 ↑ 3: 8.3 ↓ 4: 9.0 → 5: 9.3 ↑
Serie 49	Total 245	Serie 43	Total 288
7. Serie 5 Skott 	1: 7.1 ↘ 2: 8.7 → 3: 8.0 ← 4: 9.0 ↗ 5: 10.1 ↗		
Serie 42	Total 330		

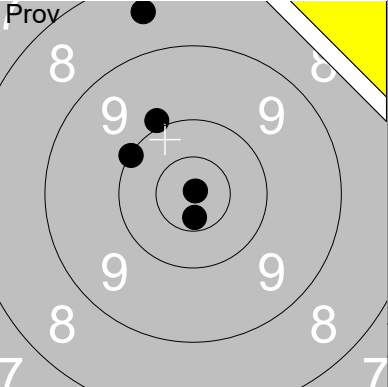
Skjutlag	Tavla	Johnny Wallberg	
1	10		
Ramselefors	Loos	C	Gä
07.07.2019	Tavelträffen 2019	Ramselefors SKF	
Prov 	1: 10.9x ↗ 2: 8.5 ↑ 3: 10.0 ↖ 4: 10.7x ↓ 5: 9.9 ↗ Serie 47 Total 0	1. Serie 5 Skott 	1: 9.9 → 2: 10.3 ↗ 3: 10.0 ↓ 4: 9.7 ↘ 5: 10.2 ↘ Serie 48 Total 48
2. Serie 5 Skott 	1: 9.8 ← 2: 9.7 ← 3: 10.7x → 4: 10.9x ↓ 5: 10.8x ← Serie 48 Total 96	3. Serie 5 Skott 	1: 10.5x → 2: 10.3 ↗ 3: 10.3 ← 4: 8.7 ↑ 5: 9.6 ↗ Serie 47 Total 143
4. Serie 5 Skott 	1: 10.5x ↘ 2: 10.2 ← 3: 10.2 ← 4: 10.3 ← 5: 9.0 ↘ Serie 49 Total 192	Prov 	1: 9.6 ← 2: 9.9 ↗ 3: 10.1 ← 4: 9.9 ← 5: 8.4 ↘ 6: 9.2 ↘ Serie 54 Total 192
5. Serie 5 Skott 	1: 9.1 ↘ 2: 10.2 ↓ 3: 9.5 ↗ 4: 9.5 ← 5: 10.1 ↑ Serie 47 Total 239	6. Serie 5 Skott 	1: 7.8 ↖ 2: 8.6 ↑ 3: 9.4 ↗ 4: 9.0 ↓ 5: 7.9 ↗ Serie 40 Total 279
7. Serie 5 Skott 	1: 9.9 → 2: 8.8 ↖ 3: 10.0 ↑ 4: 9.3 ↓ 5: 7.2 ↘ Serie 43 Total 322		

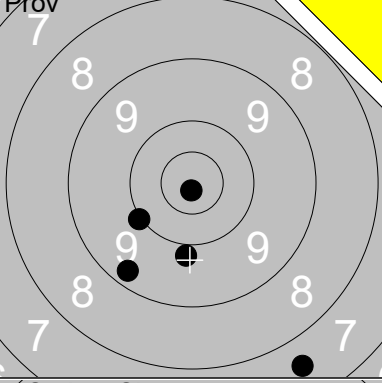
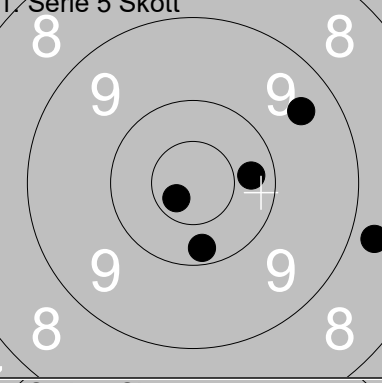
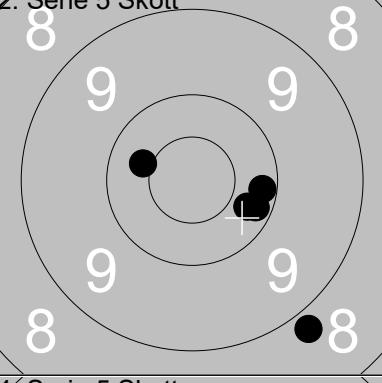
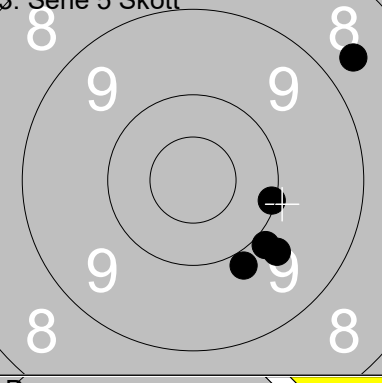
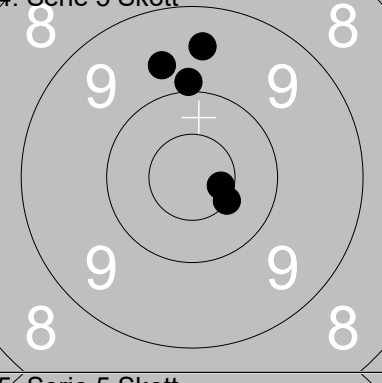
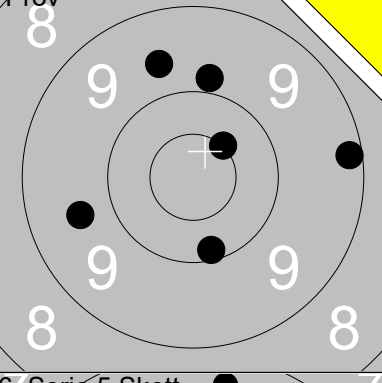
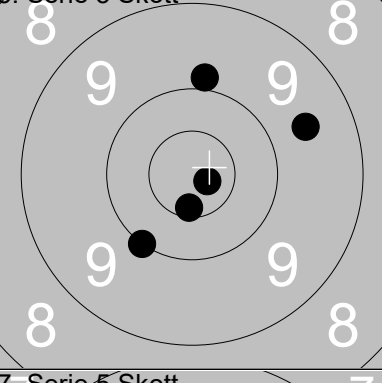
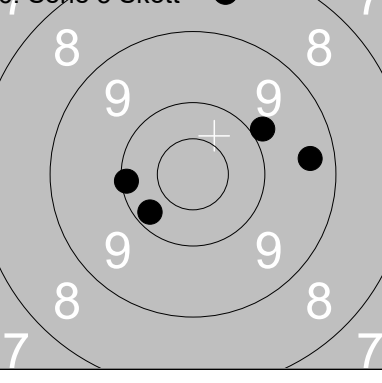
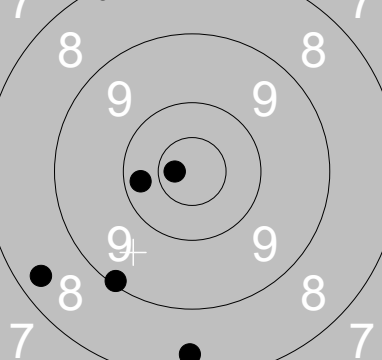
	<p>1: 7.6 ↘ 2: 9.9 ↓ 3: 10.0 ← 4: 10.8x ↓ 5: 9.3 ↓</p> <p>Serie 45 Total 0</p>	<p>1. Serie 5 Skott</p>  <p>1: 8.7 → 2: 10.2 ↓ 3: 10.3 → 4: 10.7x ← 5: 9.5 ↗</p> <p>Serie 47 Total 47</p>
<p>2. Serie 5 Skott</p>  <p>1: 10.4 ← 2: 10.2 → 3: 10.2 ↘ 4: 8.8 ↘ 5: 10.3 ↘</p> <p>Serie 48 Total 95</p>	<p>3. Serie 5 Skott</p>  <p>1: 9.9 ↘ 2: 9.9 ↘ 3: 9.7 ↘ 4: 10.1 → 5: 8.7 ↗</p> <p>Serie 45 Total 140</p>	
<p>4. Serie 5 Skott</p>  <p>1: 9.9 ↑ 2: 9.5 ↑ 3: 10.5x ↘ 4: 10.6x → 5: 9.7 ↑</p> <p>Serie 47 Total 187</p>	<p>Provs</p>  <p>1: 9.6 ← 2: 9.6 ↑ 3: 10.5x ↗ 4: 9.9 ↑ 5: 9.2 → 6: 10.1 ↓</p> <p>Serie 56 Total 187</p>	
<p>5. Serie 5 Skott</p>  <p>1: 10.6x ↓ 2: 9.9 ↑ 3: 10.0 ↓ 4: 10.8x → 5: 9.6 →</p> <p>Serie 48 Total 235</p>	<p>6. Serie 5 Skott</p>  <p>1: 9.4 → 2: 9.9 ↗ 3: 8.4 ↑ 4: 10.1 ← 5: 10.2 ↙</p> <p>Serie 46 Total 281</p>	
<p>7. Serie 5 Skott</p>  <p>1: 9.1 ↓ 2: 8.4 ← 3: 10.7x ← 4: 10.2 ← 5: 8.4 ↓</p> <p>Serie 45 Total 326</p>		

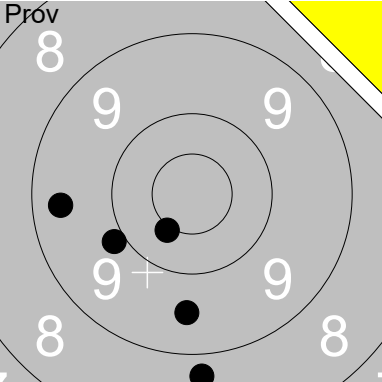
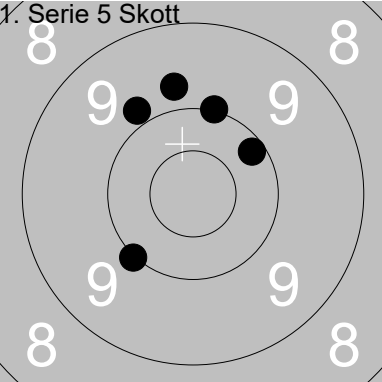
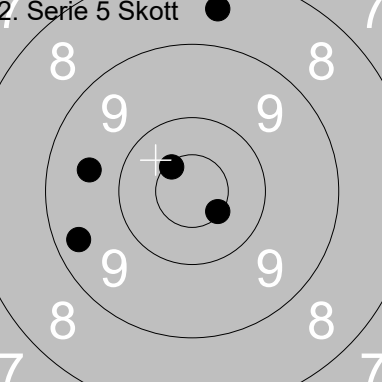
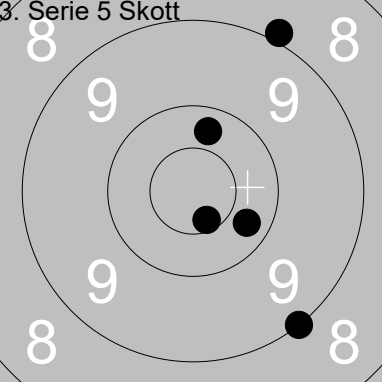
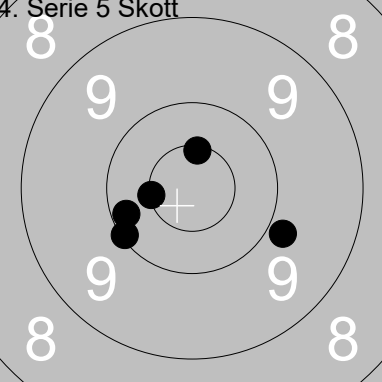
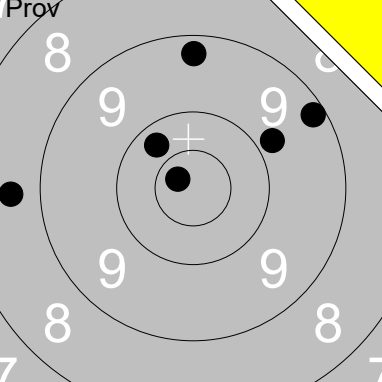
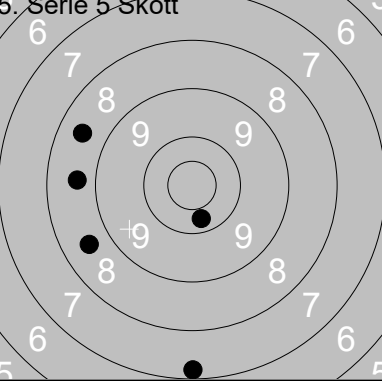
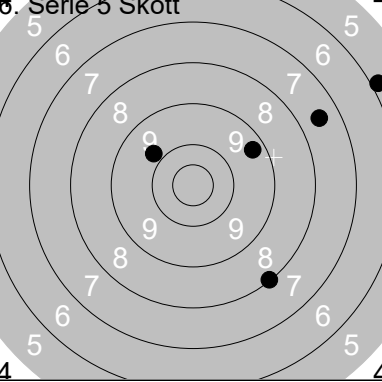
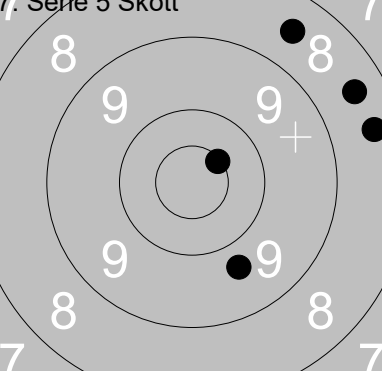
Skjutlag	Tavla	Berndt Steffen					
1	12	Ramselefors	Frötuna	C	St		
07.07.2019		Tavelträffen 2019	Ramselefors SKF				
Pröv 	1: 8.8 ↓ 2: 9.6 ↓↓ 3: 9.9 ← 4: 9.4 ← 5: 10.4x ↓	1. Serie 5 Skott 	1: 10.0 ↑ 2: 9.9 ↖ 3: 10.0 ↙ 4: 9.8 ↑ 5: 10.2 ↗	Serie	45	Serie	48
	Total	0		Total	48		48
2. Serie 5 Skott 	1: 9.6 ← 2: 9.3 ← 3: 8.5 ↑ 4: 10.5x ↘ 5: 10.6x ↗	3. Serie 5 Skott 	1: 8.9 ↑ 2: 10.6x ↓ 3: 10.3 ↑ 4: 10.3 ↘ 5: 9.0 ↓	Serie	46	Serie	47
	Total	94		Total	141		141
4. Serie 5 Skott 	1: 10.2 ← 2: 10.5x ← 3: 10.5x ↑ 4: 9.8 → 5: 10.1 ←	Pröv 	1: 9.8 ↗ 2: 10.3 ↖ 3: 8.6 ← 4: 10.7x ↖ 5: 9.2 ↗ 6: 9.3 ↑	Serie	49	Serie	55
	Total	190		Total	190		190
5. Serie 5 Skott 	1: 8.6 ↙ 2: 8.5 ↖ 3: 7.2 ↓ 4: 10.3 ↓ 5: 8.7 ←	6. Serie 5 Skott 	1: 5.9 ↗ 2: 9.8 ↖ 3: 7.5 ↗ 4: 8.1 ↘ 5: 9.3 ↗	Serie	41	Serie	38
	Total	231		Total	269		269
7. Serie 5 Skott 	1: 8.5 ↗ 2: 10.5x ↗ 3: 9.7 ↓ 4: 8.5 ↑ 5: 8.4 →			Serie	43		
	Total	312					

Skjutlag	Tavla	Bert-Ove Hägglund					
1	13	Ramselefors	Ramselefors	D	Vb		
07.07.2019	Tavelträffen 2019	Ramselefors SKF					
Prov 	1: 10.0 ↑ 2: 10.1 → 3: 9.4 ↓ 4: 9.2 ← 5: 10.6x ↙	1. Serie 5 Skott 	1: 8.6 ↗ 2: 9.6 ↖ 3: 9.9 ↓ 4: 10.0 ↘ 5: 10.2 ↓	Serie	48	Serie	46
	Total	0	Total	46			46
2. Serie 5 Skott 	1: 9.5 → 2: 10.6x ↑ 3: 8.3 → 4: 9.7 ← 5: 9.6 ↖	3. Serie 5 Skott 	1: 9.7 ↗ 2: 9.8 ↖ 3: 9.8 ↗ 4: 10.2 ↗ 5: 10.9x ↖	Serie	45	Serie	47
	Total	91	Total	138			138
4. Serie 5 Skott 	1: 9.0 ↖ 2: 8.8 → 3: 9.0 → 4: 10.2 ↖ 5: 9.6 ←	Prov 	1: 9.3 ↑ 2: 10.2 ← 3: 9.6 ↗ 4: 9.7 ↖	Serie	45	Serie	37
	Total	183	Total	183			183
5. Serie 5 Skott 	1: 9.7 → 2: 9.2 ↗ 3: 10.3 ↗ 4: 9.1 → 5: 9.2 ↗	6. Serie 5 Skott 	1: 10.2 ↗ 2: 8.0 → 3: 10.5x ← 4: 9.6 ↗ 5: 10.2 ↘	Serie	46	Serie	47
	Total	229	Total	276			276
7. Serie 5 Skott 	1: 10.8x ↗ 2: 9.2 ↑ 3: 10.0 ↗ 4: 10.3 → 5: 10.7x ↖			Serie	49		
	Total	325					

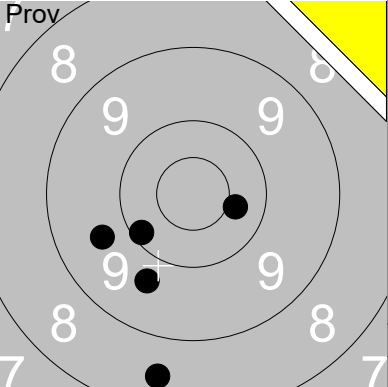
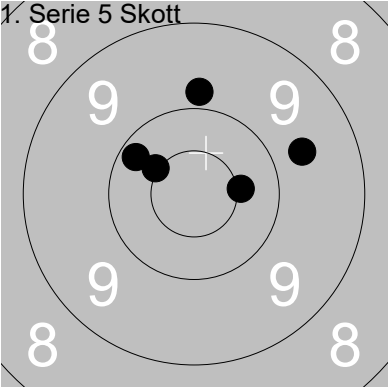
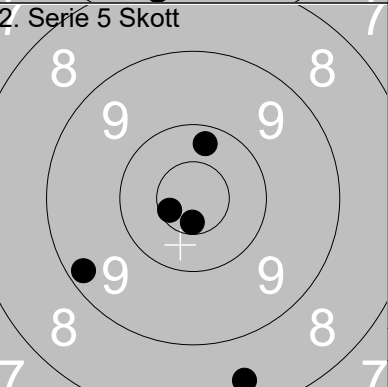
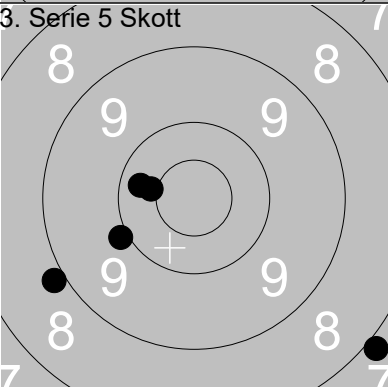
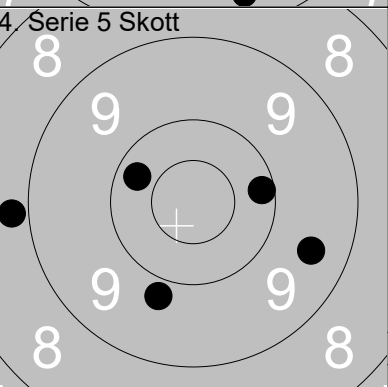
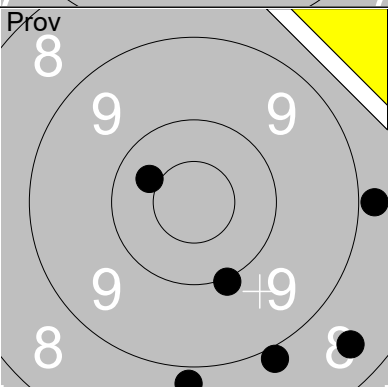
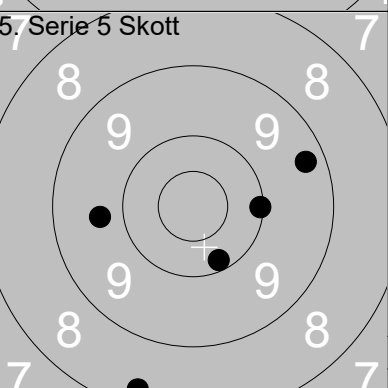
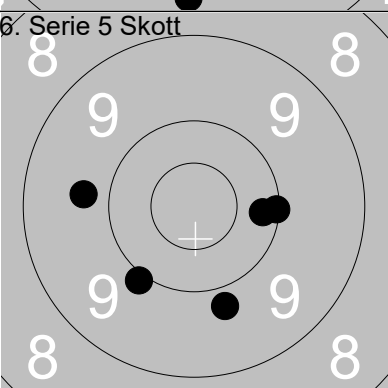
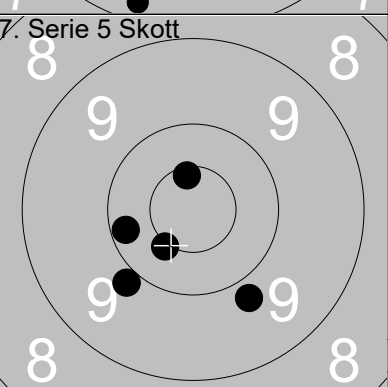
Skjutlag	Tavla	Emma Wallerström			
1	14	Ramselefors	Ununge	D	St
07.07.2019		Tavelträffen 2019		Ramselefors SKF	
Prov		1: 8.5 ↓ 2: 10.4 → 3: 10.1 ↙ 4: 9.7 ↙ 5: 9.7 ↓	1. Serie 5 Skott		1: 9.8 ↑ 2: 10.4x ↖ 3: 9.7 → 4: 10.4x → 5: 10.2 ↖
		Serie 46		Serie 48	
		Total 0		Total 48	
2. Serie 5 Skott		1: 10.2 ↑ 2: 9.2 ↙ 3: 10.6x ↙ 4: 10.6x ↓ 5: 8.4 ↓	3. Serie 5 Skott		1: 9.9 ↙ 2: 10.4 ↙ 3: 8.9 ↙ 4: 10.3 ↙ 5: 7.9 ↓
		Serie 47		Serie 44	
		Total 95		Total 139	
4. Serie 5 Skott		1: 10.2 → 2: 9.5 → 3: 9.8 ↓ 4: 8.8 ↙ 5: 10.3 ↙	Prov		1: 8.9 ↓ 2: 8.8 → 3: 10.0 ↓ 4: 8.5 ↓ 5: 10.4 ↗ 6: 8.8 ↓
		Serie 46		Serie 52	
		Total 185		Total 185	
5. Serie 5 Skott		1: 9.7 ↙ 2: 9.3 → 3: 10.2 ↓ 4: 10.1 → 5: 8.3 ↓	6. Serie 5 Skott		1: 10.1 → 2: 10.2 → 3: 10.0 ↙ 4: 9.7 ↙ 5: 9.8 ↓
		Serie 46		Serie 48	
		Total 231		Total 279	
7. Serie 5 Skott		1: 10.5x ↙ 2: 10.6x ↑ 3: 9.8 ↓ 4: 10.2 ↙ 5: 9.9 ↙			
		Serie 48			
		Total 327			

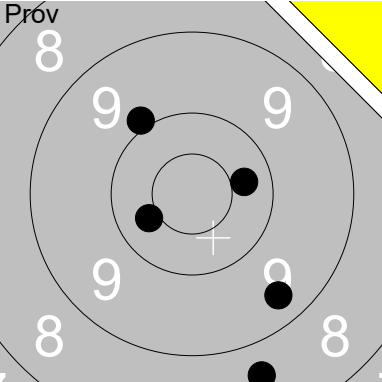
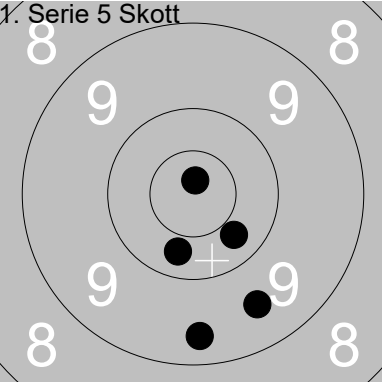
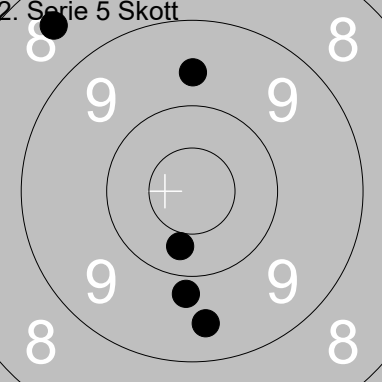
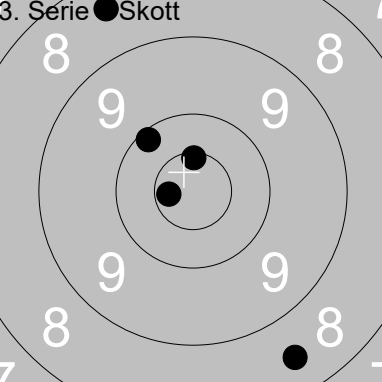
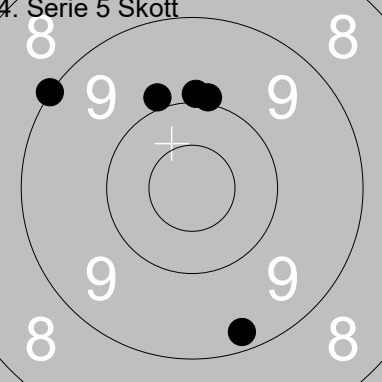
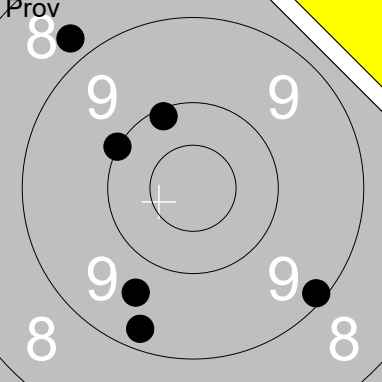
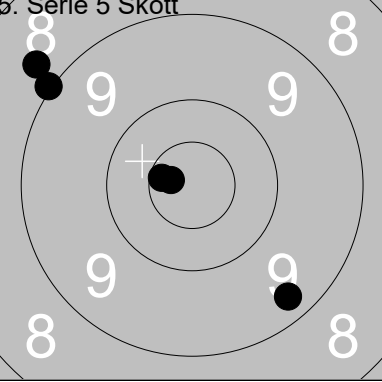
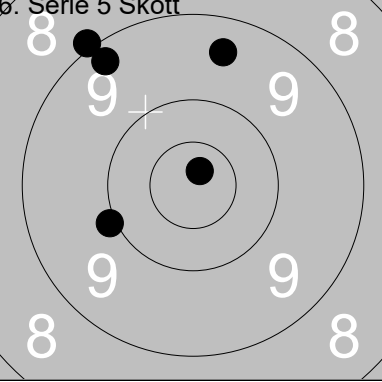
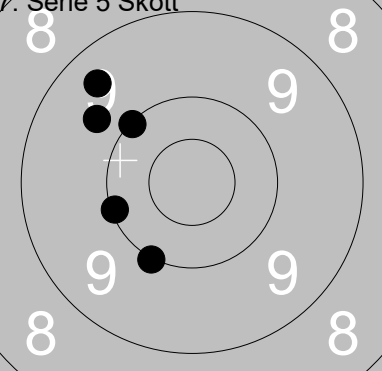
Skjutlag	Tavla	Josefin Magnusson			
1	16	Ramselefors	Västerås Friv Skarp	D	Vm
07.07.2019	Tavelträffen 2019	Ramselefors SKF			
Pröv 	1: 10.3 → 2: 9.4 ↓ 3: 9.9 ↗ 4: 8.6 ↓ 5: 10.4 ↙	1. Serie 5 Skott 	1: 10.3 ↓ 2: 10.8x ↑ 3: 10.3 ↓ 4: 9.4 ↓ 5: 9.5 ↓		
	Serie 46 Total 0		Serie 48 Total 48		
2. Serie 5 Skott 	1: 9.8 ↓ 2: 10.3 ↓ 3: 8.5 ↗ 4: 9.5 ↓ 5: 9.6 ↑	3. Serie 5 Skott 	1: 10.1 ↗ 2: 10.7x ← 3: 8.4 ↗ 4: 10.6x ↑ 5: 8.5 ↓		
	Serie 45 Total 93		Serie 46 Total 139		
4. Serie 5 Skott 	1: 10.0 ↑ 2: 9.9 ↗ 3: 9.3 ↓ 4: 9.0 ↗ 5: 9.9 ↑	Pröv 	1: 9.1 ↓ 2: 9.6 ↓ 3: 10.1 ↗ 4: 9.3 ↓ 5: 10.0 ↗ 6: 8.8 ↗		
	Serie 46 Total 185		Serie 55 Total 185		
5. Serie 5 Skott 	1: 9.0 ↗ 2: 10.7x ← 3: 8.7 ↗ 4: 10.6x ← 5: 9.3 ↓	6. Serie 5 Skott 	1: 9.3 ↗ 2: 9.0 ↗ 3: 10.0 ← 4: 9.4 ↑ 5: 10.8x ↑		
	Serie 46 Total 231		Serie 47 Total 278		
7. Serie 5 Skott 	1: 9.7 ↗ 2: 10.0 ↗ 3: 10.1 ← 4: 9.4 ↗ 5: 10.0 ↓				
	Serie 48 Total 326				

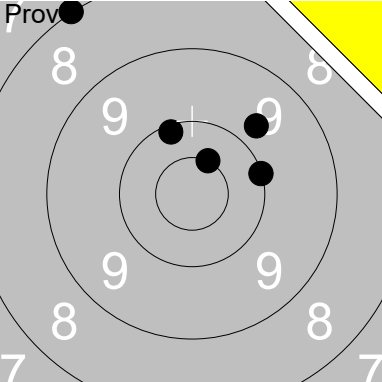
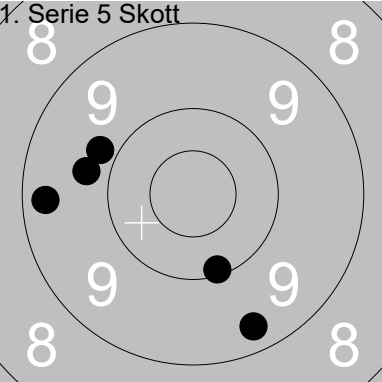
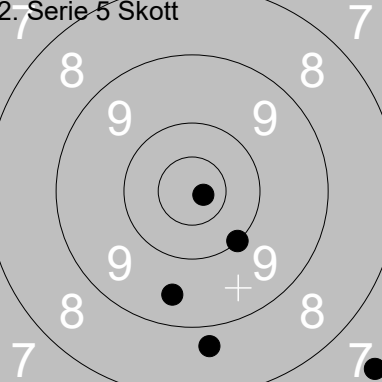
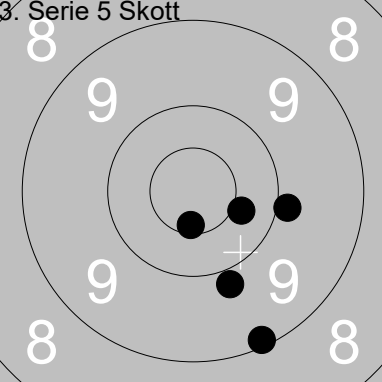
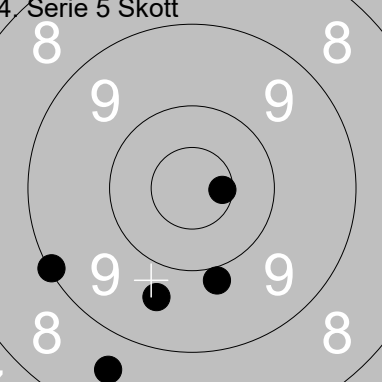
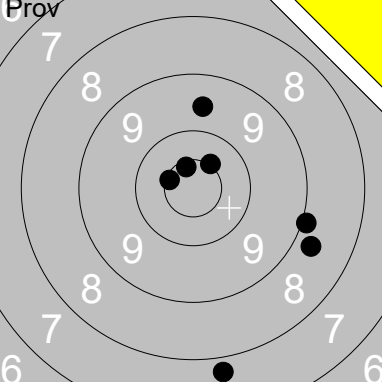
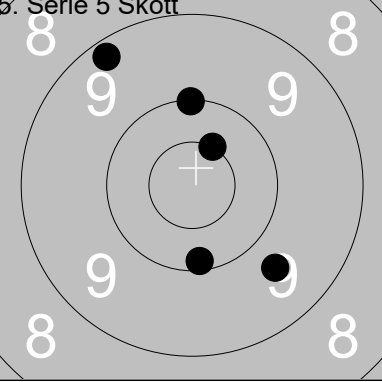
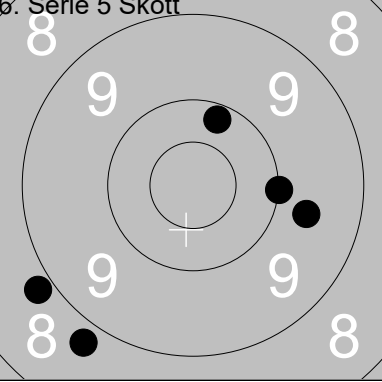
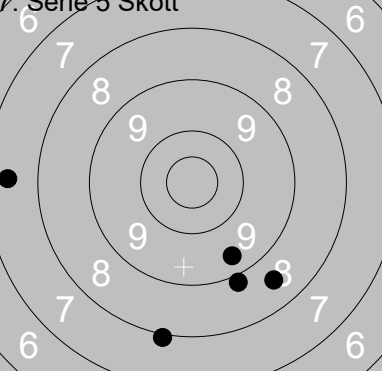
Skjutlag	Tavla	Göte Ericsson		D	Vn
Ramselefors	Anundsjö				
07.07.2019	Tavelträffen 2019	Ramselefors SKF			
Prov		1: 8.0 ↖ 2: 10.1 ↑ 3: 10.5x ↑ 4: 9.7 ↗ 5: 10.0 →	1. Serie 5 Skott		1: 9.3 ← 2: 9.8 ↗ 3: 9.8 ↖ 4: 9.3 ↓ 5: 10.1 ↓
	Serie 47	Total 0		Serie 46	Total 46
2. Serie 5 Skott		1: 7.3 ↓ 2: 10.8x → 3: 10.0 ↓ 4: 9.5 ↓ 5: 8.7 ↓	3. Serie 5 Skott		1: 10.4 → 2: 9.9 ↓ 3: 10.6x ↓ 4: 9.1 ↓ 5: 9.9 →
	Serie 44	Total 90		Serie 47	Total 137
4. Serie 5 Skott		1: 9.6 ↓ 2: 9.9 ↓ 3: 8.6 ↓ 4: 9.1 ← 5: 10.6x →	Prov		1: 10.6x ↑ 2: 9.6 ↑ 3: 8.7 → 4: 9.0 → 5: 10.6x ← 6: 7.8 ↓ 7: 10.5x ↗
	Serie 45	Total 182		Serie 63	Total 182
5. Serie 5 Skott		1: 9.2 ↖ 2: 10.0 ↑ 3: 10.5x ↗ 4: 9.7 ↓ 5: 10.1 ↓	6. Serie 5 Skott		1: 10.2 ↑ 2: 10.0 → 3: 8.8 ← 4: 9.7 → 5: 8.8 ↓
	Serie 48	Total 230		Serie 45	Total 275
7. Serie 5 Skott		1: 7.4 ← 2: 9.4 ↓ 3: 8.6 ↓ 4: 8.0 ↓ 5: 8.9 ↓			
	Serie 40	Total 315			

Skjutlag	Tavla	Mathias Fredriksson			
2	2	Ramselefors	Ramselefors	D	Vb
07.07.2019	Tavelträffen 2019	Ramselefors SKF			
	1: 10.2 ↓ 2: 9.9 ↓ 3: 9.7 ↓ 4: 9.2 ↓ 5: 10.0 ↖		1: 10.3 ← 2: 10.5x ↖ 3: 9.3 ← 4: 10.5x ↗ 5: 9.7 ↗		
	Serie 47		Serie 48		
	Total 0		Total 48		
	1: 8.6 ↓ 2: 8.8 ↓ 3: 8.2 ↗ 4: 9.4 ↗ 5: 9.1 ↓		1: 10.3 ↗ 2: 8.2 ↗ 3: 8.9 ↑ 4: 10.8x ↓ 5: 8.3 ↗		
	Serie 42		Serie 44		
	Total 90		Total 134		
	1: 10.5x ← 2: 10.1 ↓ 3: 8.9 ↓ 4: 10.3 ↓ 5: 8.6 →		1: 9.0 ↑ 2: 9.3 → 3: 9.7 → 4: 9.1 ↓ 5: 9.3 ↓ 6: 9.3 →		
	Serie 46		Serie 54		
	Total 180		Total 180		
	1: 10.3 ↓ 2: 9.0 ↓ 3: 9.2 ↓ 4: 9.2 → 5: 9.5 →		1: 10.5x ← 2: 9.5 ↘ 3: 10.0 ↗ 4: 9.0 ↑ 5: 10.1 ↓		
	Serie 46		Serie 48		
	Total 226		Total 274		
	1: 10.6x → 2: 10.1 → 3: 9.8 ↓ 4: 9.4 ↗ 5: 10.8x ↗				
	Serie 48				
	Total 322				

Skjutlag	Tavla	Stefan Thorin	
2	3	Umeå	D Vb
07.07.2019	Tavelträffen 2019	Ramselefors SKF	
Prov 	1. 8.2 ↑ 2. 9.4 ↓ 3. 9.6 → 4. 9.6 ↗ 5. 10.1 ↓	1. Serie 5 Skott 	1. 9.4 ← 2. 10.0 ↗ 3. 10.3 ↗ 4. 9.8 ↗ 5. 10.5x ↗
Serie 45	Total 0	Serie 48	Total 48
2. Serie 5 Skott 	1. 7.6 ↗ 2. 9.6 ↓ 3. 9.5 ← 4. 9.1 ↗ 5. 10.0 ↗	3. Serie 5 Skott 	1. 10.1 ↗ 2. 10.7x ↓ 3. 10.0 ↗ 4. 10.3 ↓ 5. 9.9 ↓
Serie 44	Total 92	Serie 49	Total 141
4. Serie 5 Skott 	1. 8.9 ↗ 2. 10.7x ↗ 3. 9.4 → 4. 10.5x ↓ 5. 9.9 ↓	Prov 	1. 9.3 ↑ 2. 8.8 → 3. 9.4 ↓ 4. 9.3 ← 5. 10.5x ↙
Serie 46	Total 187	Serie 45	Total 187
5. Serie 5 Skott 	1. 9.9 ↗ 2. 10.0 ← 3. 8.9 ↗ 4. 9.4 ↓ 5. 9.9 →	6. Serie 5 Skott 	1. 10.0 ↗ 2. 9.5 ↓ 3. 10.0 → 4. 9.4 ↓ 5. 9.2 ↓
Serie 45	Total 232	Serie 47	Total 279
7. Serie 5 Skott 	1. 9.7 → 2. 10.7x ↗ 3. 10.7x ↗ 4. 9.5 ↓ 5. 10.7x ↓		
Serie 48	Total 327		

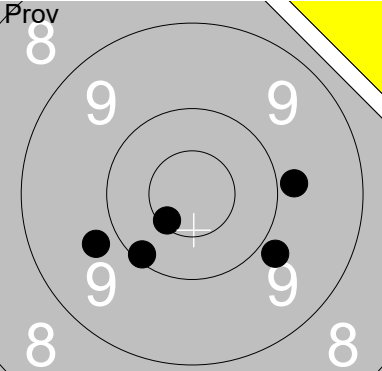
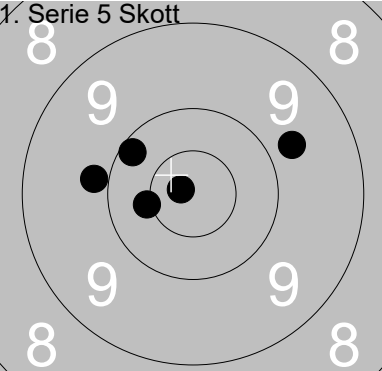
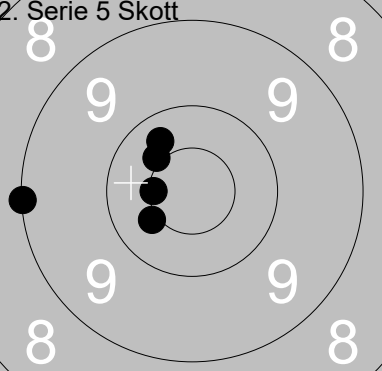
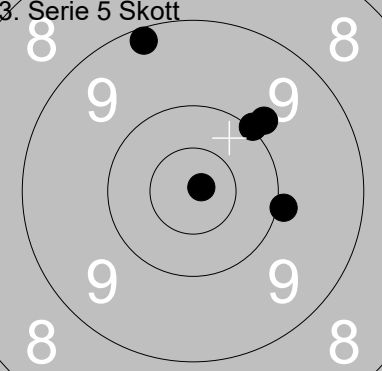
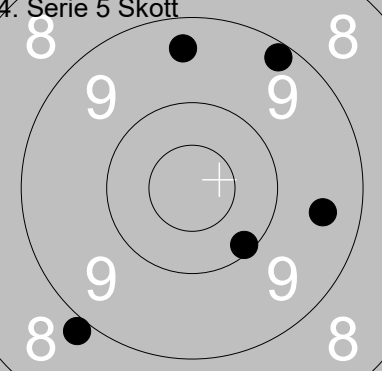
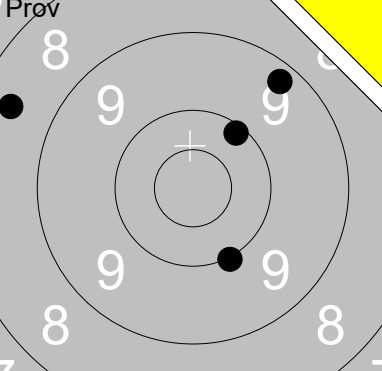
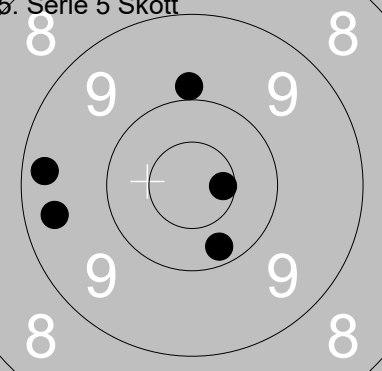
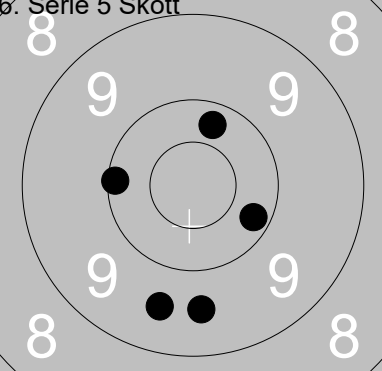
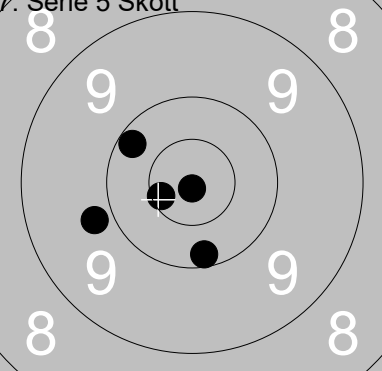
Skjutlag	Tavla	Ove Gustafsson	
2	4	Ramselefors	Solberga
07.07.2019	Tavelträffen 2019	Ramselefors SKF	
Prov 	1: 9.8 → 2: 9.8 ↘ 3: 10.6x ↙ 4: 10.1 ↙ 5: 9.8 ←	1. Serie 5 Skott 	1: 10.4x ← 2: 9.7 → 3: 10.2 ↖ 4: 10.8x ↖ 5: 9.9 ←
	Serie 47		Serie 48
	Total 0		Total 48
2. Serie 5 Skott 	1: 10.4x ↗ 2: 10.5x ← 3: 9.0 ← 4: 10.3 ↗ 5: 10.4x ↙	3. Serie 5 Skott 	1: 9.2 ↑ 2: 9.9 → 3: 10.0 ↗ 4: 10.9x ↗ 5: 9.9 ↗
	Serie 49		Serie 47
	Total 97		Total 144
4. Serie 5 Skott 	1: 9.5 → 2: 9.2 ↗ 3: 10.1 ↘ 4: 9.4 ↑ 5: 8.9 ↘	Prov 	1: 9.3 ↗ 2: 10.1 ↗ 3: 10.0 ↘ 4: 8.5 ↖
	Serie 45		Serie 37
	Total 189		Total 189
5. Serie 5 Skott 	1: 9.3 ← 2: 9.4 ← 3: 10.2 ↘ 4: 10.6x → 5: 9.9 ↑	6. Serie 5 Skott 	1: 9.6 ↓ 2: 10.3 ↑ 3: 10.1 ← 4: 9.6 ↓ 5: 10.2 →
	Serie 47		Serie 48
	Total 236		Total 284
7. Serie 5 Skott 	1: 10.6x ← 2: 10.2 ↖ 3: 9.8 ← 4: 10.9x ↘ 5: 10.2 ↘		
	Serie 49		
	Total 333		

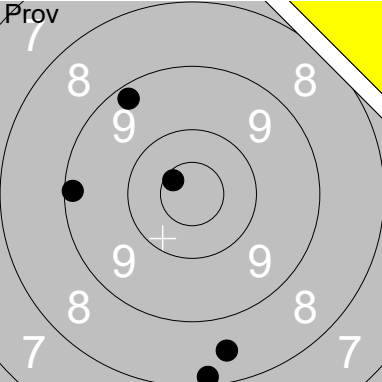
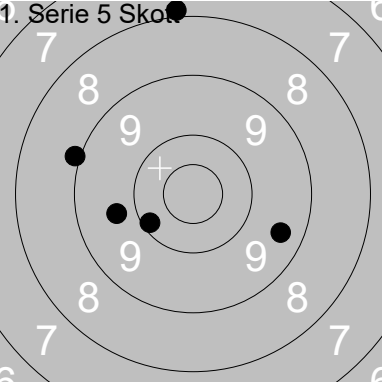
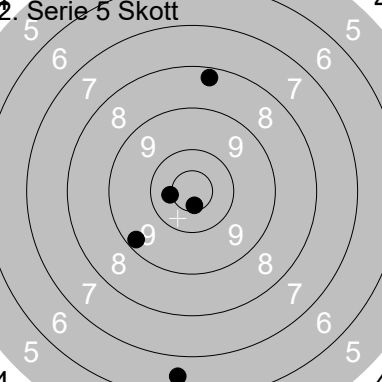
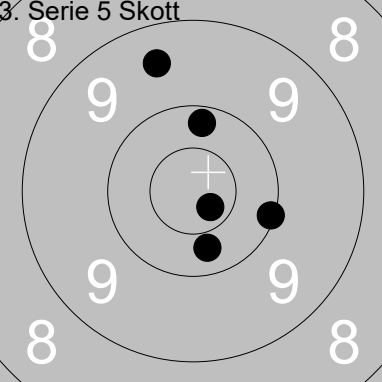
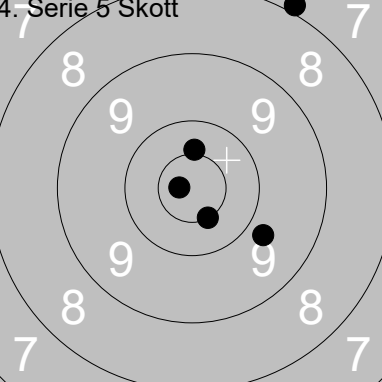
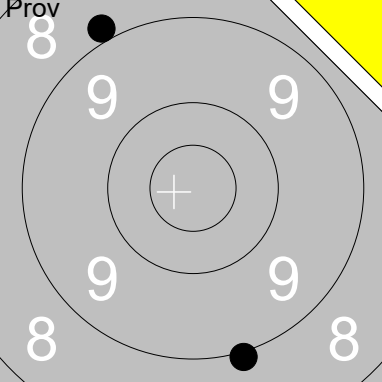
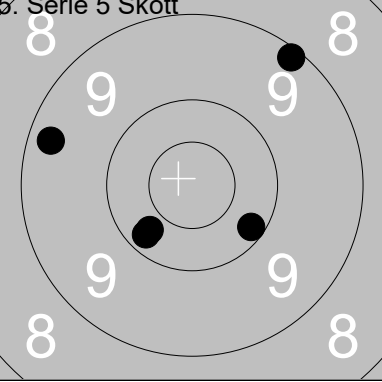
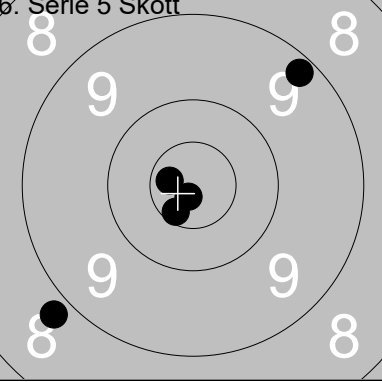
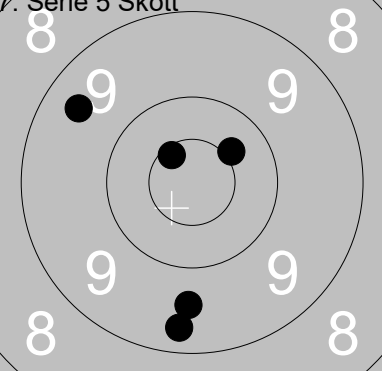
Skjutlag	Tavla	Martin Blombäck		
2	5	Ramselefors	Piteå	D No
07.07.2019	Tavelträffen 2019	Ramselefors SKF		
	1: 8.2 ↓ 2: 9.2 ← 3: 8.5 ↓↓ 4: 10.6x ↗ 5: 9.2 ↗		1: 7.9 ↑ 2: 9.4 → 3: 10.1 ↙ 4: 9.7 ← 5: 8.9 ←	
Serie 44	Total 0	Serie 43	Total 43	
	1: 8.3 ↑ 2: 6.6 ↓ 3: 9.2 ↙ 4: 10.6x ↓ 5: 10.4x ←		1: 9.5 ↑ 2: 10.3 ↓ 3: 10.1 → 4: 10.7x ↘ 5: 10.2 ↑	
Serie 43	Total 86	Serie 49	Total 135	
	1: 7.9 ↗ 2: 9.8 ↘ 3: 10.8x ← 4: 10.4x ↑ 5: 10.5x ↓		1: 8.9 ↗ 2: 9.0 ↓	
Serie 46	Total 181	Serie 17	Total 181	
	1: 9.1 ↗ 2: 10.2 → 3: 10.3 ↙ 4: 9.3 ← 5: 10.2 ↙		1: 10.7x ← 2: 10.6x ↓ 3: 9.2 ↗ 4: 10.8x ↓ 5: 8.8 ↙	
Serie 48	Total 229	Serie 47	Total 276	
	1: 10.4 ↗ 2: 9.6 ↓ 3: 9.4 ↗ 4: 9.3 ↓ 5: 10.6x ↗			
Serie 47	Total 323			

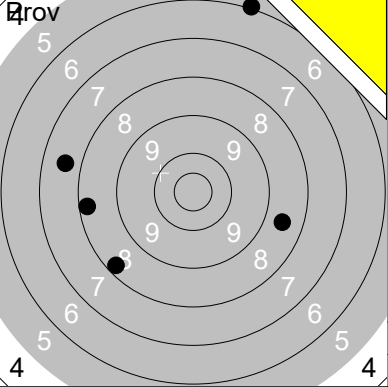
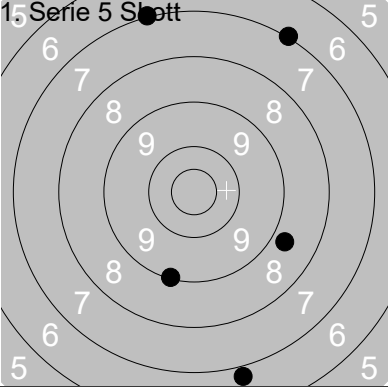
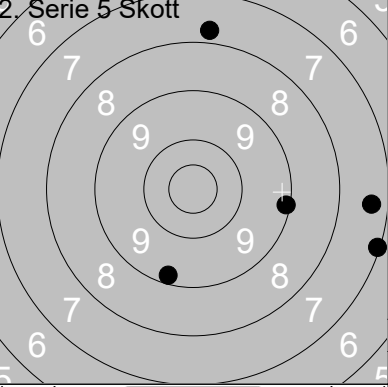
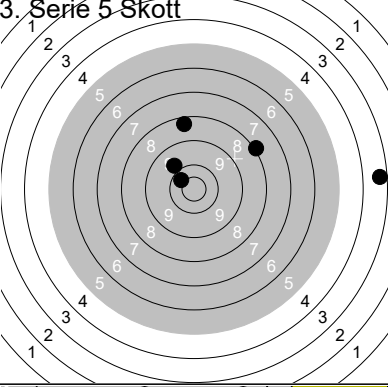
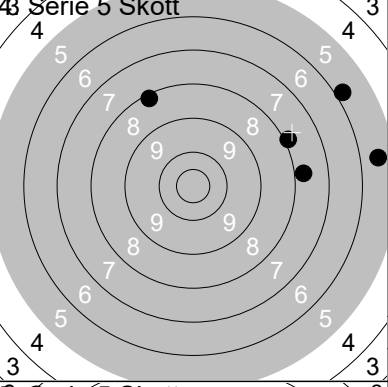
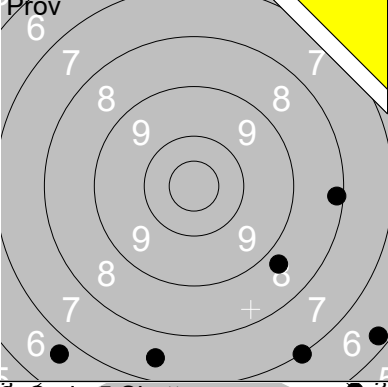
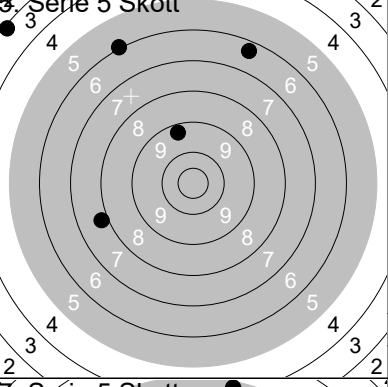
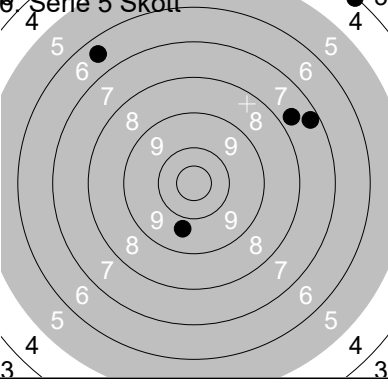
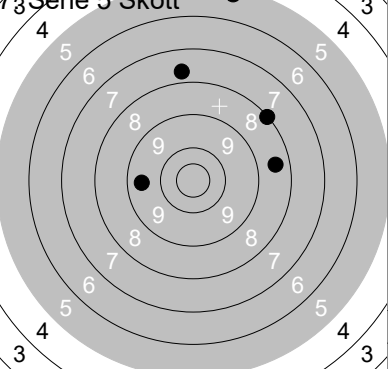
Skjutlag	Tavla	Wolfgang Voge		D	Vb
2	6	Ramselefors	Ramselefors		
07.07.2019	Tavelträffen 2019	Ramselefors SKF			
1. Proov	1. Serie 5 Skott	1: 8.3 ← 2: 7.6 ← 3: 6.0 ↑ 4: 8.6 → 5: 8.3 ↙	15. Serie 5 Skott	1: 9.1 ↓ 2: 7.0 ↑ 3: 8.7 → 4: 7.0 ↑ 5: 6.8 ↓	
		Serie 37 Total 0	Serie 37 Total 37	Serie 37 Total 37	
2. Serie 5 Skott	3. Serie 5 Skott	1: 9.1 → 2: 7.8 ↑ 3: 9.2 ↓ 4: 7.4 → 5: 7.1 →	1. Serie 5 Skott	1: 8.0 ↗ 2: 9.8 ↗ 3: 10.3 ↗ 4: 8.3 ↑ 5: 3.3 →	
		Serie 39 Total 76	Serie 38 Total 114	Serie 38 Total 114	
4. Serie 5 Skott	6. Proov	1: 5.5 → 2: 7.8 → 3: 5.8 ↗ 4: 7.9 ↗ 5: 8.1 ↗	4. Serie 5 Skott	1: 6.7 ↓ 2: 6.3 ↓ 3: 7.5 ↓ 4: 8.7 ↓ 5: 8.2 → 6: 7.0 ↓	
		Serie 32 Total 146	Serie 42 Total 146	Serie 42 Total 146	
5. Serie 5 Skott	8. Serie 5 Skott	1: 9.3 ↑ 2: 7.8 ← 3: 3.1 ↗ 4: 6.0 ↗ 5: 6.3 ↑	5. Serie 5 Skott	1: 9.7 ↓ 2: 4.1 ↗ 3: 6.5 ↗ 4: 7.3 ↗ 5: 7.7 ↗	
		Serie 31 Total 177	Serie 33 Total 210	Serie 33 Total 210	
7. Serie 5 Skott		1: 8.5 → 2: 7.7 ↑ 3: 5.2 ↑ 4: 9.5 ← 5: 8.1 ↗			
		Serie 37 Total 247			

Prov	1. Serie 5 Skott	2. Serie 5 Skott	3. Serie 5 Skott	4. Serie 5 Skott	5. Serie 5 Skott	6. Serie 5 Skott	7. Serie 5 Skott
	<p>1: 9.9 →</p> <p>2: 9.9 →</p> <p>3: 10.2 ↑</p> <p>4: 10.4 ←</p> <p>5: 10.2 ←</p>			<p>1: 10.4 ↙</p> <p>2: 10.2 →</p> <p>3: 9.8 ↑</p> <p>4: 10.6x ↙</p> <p>5: 10.1 ↙</p>	<p>Serie 48</p> <p>Total 0</p>	<p>Serie 49</p> <p>Total 49</p>	
	<p>1: 9.9 ↙</p> <p>2: 9.9 ↙</p> <p>3: 9.4 ↙</p> <p>4: 9.5 ←</p> <p>5: 10.4 ↘</p>		<p>1: 9.6 ↑</p> <p>2: 9.9 ↗</p> <p>3: 10.2 ↗</p> <p>4: 9.9 ↗</p> <p>5: 10.2 ↗</p>	<p>Serie 46</p> <p>Total 95</p>	<p>Serie 47</p> <p>Total 142</p>		
	<p>1: 9.7 ↗</p> <p>2: 10.6x ↘</p> <p>3: 9.8 ↘</p> <p>4: 10.1 ↘</p> <p>5: 10.2 ↑</p>		<p>1: 9.2 →</p> <p>2: 9.1 →</p> <p>3: 10.2 ↗</p> <p>4: 10.1 ↗</p> <p>5: 8.5 ←</p> <p>6: 8.9 →</p>	<p>Serie 48</p> <p>Total 190</p>	<p>Serie 54</p> <p>Total 190</p>		
	<p>1: 9.8 ↑</p> <p>2: 10.0 ↑</p> <p>3: 9.5 ↗</p> <p>4: 10.0 ↗</p> <p>5: 10.5x ↓</p>		<p>1: 9.3 ↙</p> <p>2: 10.3 ↗</p> <p>3: 8.9 ←</p> <p>4: 9.4 →</p> <p>5: 9.1 →</p>	<p>Serie 48</p> <p>Total 238</p>	<p>Serie 45</p> <p>Total 283</p>		
	<p>1: 9.9 ←</p> <p>2: 10.2 ←</p> <p>3: 9.6 ↑</p> <p>4: 9.9 ↗</p> <p>5: 9.7 ↗</p>						
<p>Serie 46</p> <p>Total 329</p>							

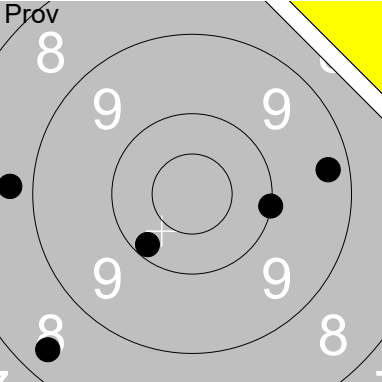
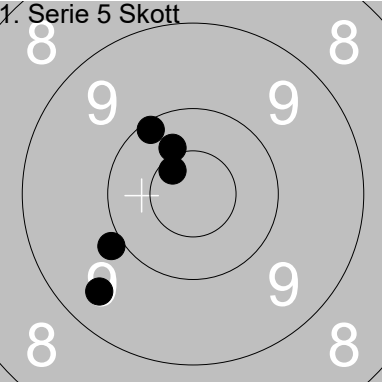
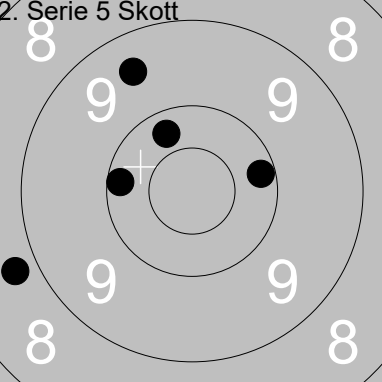
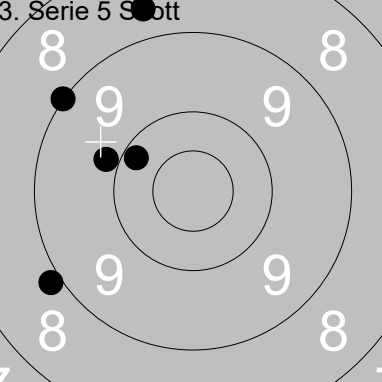
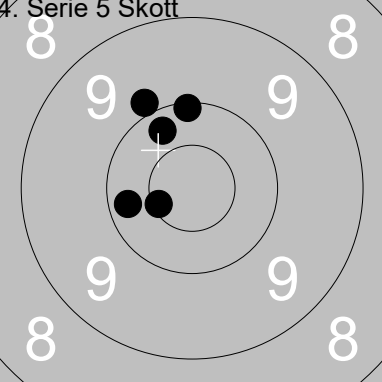
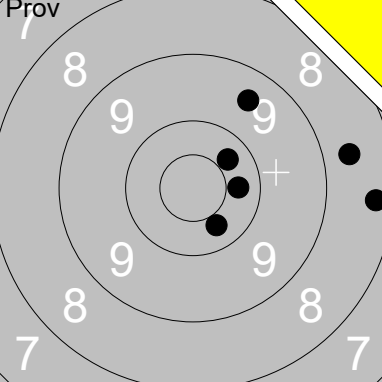
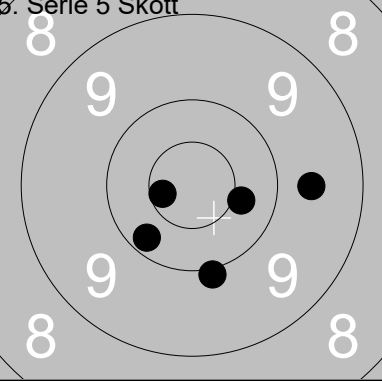
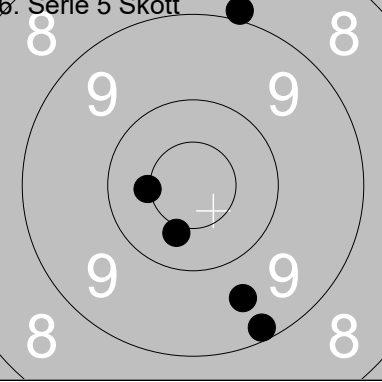
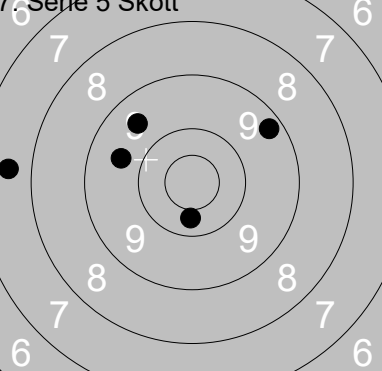
Skjutlag	Tavla	Jan-Ola Olsson	
2	8	Ramselefors	Öved-Östraby
07.07.2019	Tavelträffen 2019	Ramselefors SKF	
Pröv 	1: 10.0 → 2: 9.3 → 3: 8.8 ← 4: 10.2 ↘ 5: 8.4 ↘ Serie 45 Total 0	1. Serie 5 Skott 	1: 10.6x ↖ 2: 9.5 ↘ 3: 10.4 ↖ 4: 9.9 ↘ 5: 10.1 ↖ Serie 48 Total 48
2. Serie 5 Skott 	1: 10.2 ← 2: 8.8 ← 3: 10.3 ↖ 4: 9.5 ↖ 5: 10.2 → Serie 47 Total 95	3. Serie 5 Skott 	1: 9.9 ← 2: 8.9 ← 3: 9.0 ↖ 4: 10.2 ↖ 5: 8.7 ↖ Serie 44 Total 139
4. Serie 5 Skott 	1: 10.1 ↑ 2: 10.2 ← 3: 10.6x ← 4: 9.9 ↖ 5: 10.3 ↖ Serie 49 Total 188	Pröv 	1: 8.6 → 2: 10.3 ↘ 3: 10.3 ↗ 4: 10.3 → 5: 9.5 ↗ 6: 8.3 → Serie 55 Total 188
5. Serie 5 Skott 	1: 10.4 → 2: 10.2 ↘ 3: 10.0 ↘ 4: 10.6x ← 5: 9.6 → Serie 49 Total 237	6. Serie 5 Skott 	1: 10.5x ← 2: 8.9 ↑ 3: 9.2 ↘ 4: 10.4 ↘ 5: 9.6 ↘ Serie 46 Total 283
7. Serie 5 Skott 	1: 9.5 ↖ 2: 9.6 ← 3: 9.3 ↗ 4: 10.3 ↘ 5: 7.6 ← Serie 44 Total 327		

Skjutlag	Tavla	Mats Österlund			
2	9	Ramselefors	Ramselefors	C	Vb
07.07.2019	Tavelträffen 2019	Ramselefors SKF			
	1: 9.4 ↗ 2: 7.8 ↗ 3: 8.6 ← 4: 10.0 ↙ 5: 9.9 ↘		1: 7.9 ← 2: 9.8 ↗ 3: 8.0 ← 4: 10.0 ↗ 5: 10.6x ↑		
	Serie 43 Total 0		Serie 44 Total 44		
	1: 8.7 ↗ 2: 8.7 ↗ 3: 10.1 ↗ 4: 9.3 ↗ 5: 9.9 ↘		1: 8.5 → 2: 9.2 ↘ 3: 9.2 ↗ 4: 9.0 ↑ 5: 8.8 →		
	Serie 44 Total 88		Serie 43 Total 131		
	1: 10.1 ↘ 2: 10.3 ↘ 3: 10.7x ↘ 4: 9.8 ↗ 5: 9.2 →		1: 9.8 → 2: 8.8 → 3: 9.6 ↘ 4: 9.6 → 5: 4.6 ↑ 6: 6.7 →		
	Serie 48 Total 179		Serie 45 Total 179		
	1: 8.3 ← 2: 9.4 ← 3: 8.9 → 4: 10.1 ← 5: 10.5x ↘		1: 8.2 ↑ 2: 9.9 ↑ 3: 7.5 ← 4: 8.6 ← 5: 10.7x ↘		
	Serie 45 Total 224		Serie 42 Total 266		
	1: 9.3 ↗ 2: 8.8 ↘ 3: 8.0 ↗ 4: 10.4x ← 5: 8.3 ↘				
	Serie 43 Total 309				

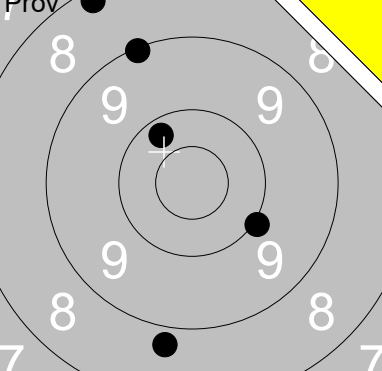
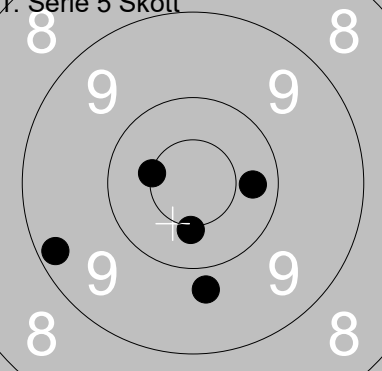
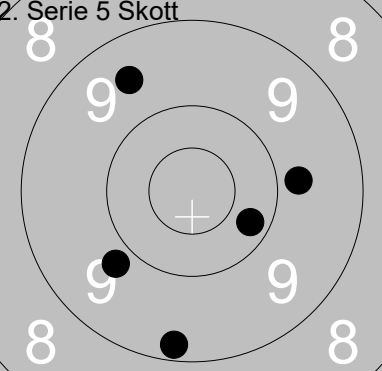
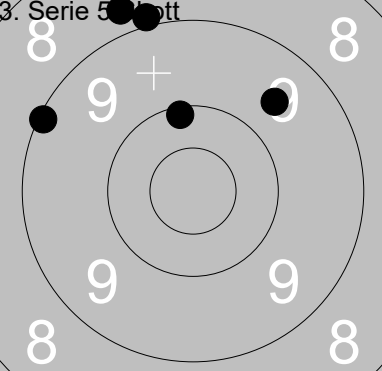
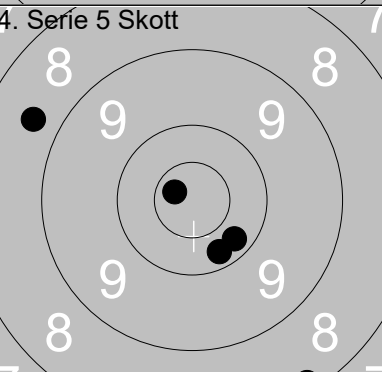
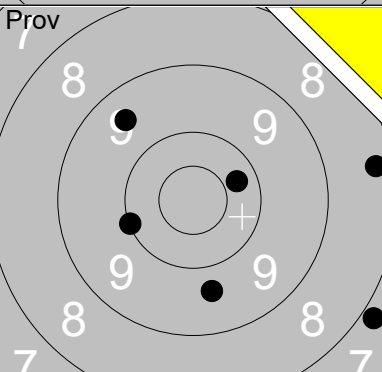
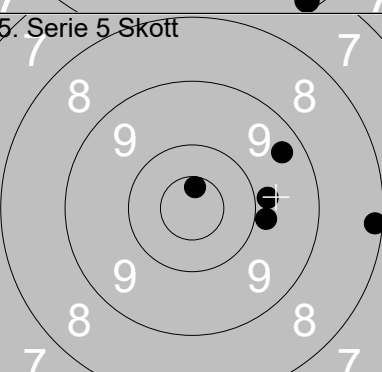
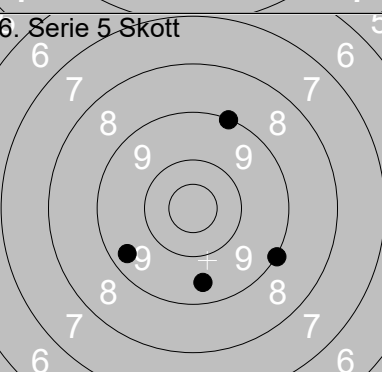
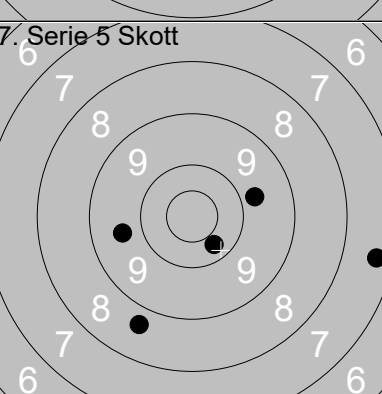
 <p>Prov</p>	<table border="1" style="width:100%; border-collapse: collapse;"> <tr><td>1:</td><td>9.1</td><td>↗</td></tr> <tr><td>2:</td><td>8.2</td><td>↗</td></tr> <tr><td>3:</td><td>10.2</td><td>↗</td></tr> <tr><td>4:</td><td>8.8</td><td>↓</td></tr> <tr><td>5:</td><td>10.0</td><td>↘</td></tr> <tr><td>Serie</td><td>45</td><td></td></tr> <tr><td>Total</td><td>0</td><td></td></tr> </table>	1:	9.1	↗	2:	8.2	↗	3:	10.2	↗	4:	8.8	↓	5:	10.0	↘	Serie	45		Total	0		 <p>1. Serie 5 Skott</p> <table border="1" style="width:100%; border-collapse: collapse;"> <tr><td>1:</td><td>10.4x</td><td>↓</td></tr> <tr><td>2:</td><td>9.8</td><td>↓</td></tr> <tr><td>3:</td><td>9.2</td><td>←</td></tr> <tr><td>4:</td><td>10.5x</td><td>←</td></tr> <tr><td>5:</td><td>10.3</td><td>→</td></tr> <tr><td>Serie</td><td>48</td><td></td></tr> <tr><td>Total</td><td>48</td><td></td></tr> </table>	1:	10.4x	↓	2:	9.8	↓	3:	9.2	←	4:	10.5x	←	5:	10.3	→	Serie	48		Total	48				
1:	9.1	↗																																													
2:	8.2	↗																																													
3:	10.2	↗																																													
4:	8.8	↓																																													
5:	10.0	↘																																													
Serie	45																																														
Total	0																																														
1:	10.4x	↓																																													
2:	9.8	↓																																													
3:	9.2	←																																													
4:	10.5x	←																																													
5:	10.3	→																																													
Serie	48																																														
Total	48																																														
 <p>2. Serie 5 Skott</p>	<table border="1" style="width:100%; border-collapse: collapse;"> <tr><td>1:</td><td>9.8</td><td>→</td></tr> <tr><td>2:</td><td>9.8</td><td>↘</td></tr> <tr><td>3:</td><td>9.2</td><td>↓</td></tr> <tr><td>4:</td><td>9.5</td><td>↗</td></tr> <tr><td>5:</td><td>10.2</td><td>↘</td></tr> <tr><td>Serie</td><td>46</td><td></td></tr> <tr><td>Total</td><td>94</td><td></td></tr> </table>	1:	9.8	→	2:	9.8	↘	3:	9.2	↓	4:	9.5	↗	5:	10.2	↘	Serie	46		Total	94		 <p>3. Serie 5 Skott</p> <table border="1" style="width:100%; border-collapse: collapse;"> <tr><td>1:</td><td>9.6</td><td>↗</td></tr> <tr><td>2:</td><td>8.8</td><td>↗</td></tr> <tr><td>3:</td><td>10.1</td><td>↑</td></tr> <tr><td>4:</td><td>9.1</td><td>←</td></tr> <tr><td>5:</td><td>8.9</td><td>↑</td></tr> <tr><td>Serie</td><td>44</td><td></td></tr> <tr><td>Total</td><td>138</td><td></td></tr> </table>	1:	9.6	↗	2:	8.8	↗	3:	10.1	↑	4:	9.1	←	5:	8.9	↑	Serie	44		Total	138				
1:	9.8	→																																													
2:	9.8	↘																																													
3:	9.2	↓																																													
4:	9.5	↗																																													
5:	10.2	↘																																													
Serie	46																																														
Total	94																																														
1:	9.6	↗																																													
2:	8.8	↗																																													
3:	10.1	↑																																													
4:	9.1	←																																													
5:	8.9	↑																																													
Serie	44																																														
Total	138																																														
 <p>4. Serie 5 Skott</p>	<table border="1" style="width:100%; border-collapse: collapse;"> <tr><td>1:</td><td>8.7</td><td>←</td></tr> <tr><td>2:</td><td>8.2</td><td>↘</td></tr> <tr><td>3:</td><td>10.2</td><td>↘</td></tr> <tr><td>4:</td><td>10.7x</td><td>↗</td></tr> <tr><td>5:</td><td>10.2</td><td>↘</td></tr> <tr><td>Serie</td><td>46</td><td></td></tr> <tr><td>Total</td><td>184</td><td></td></tr> </table>	1:	8.7	←	2:	8.2	↘	3:	10.2	↘	4:	10.7x	↗	5:	10.2	↘	Serie	46		Total	184		 <p>Prov</p> <table border="1" style="width:100%; border-collapse: collapse;"> <tr><td>1:</td><td>10.0</td><td>←</td></tr> <tr><td>2:</td><td>9.7</td><td>↓</td></tr> <tr><td>3:</td><td>7.8</td><td>↘</td></tr> <tr><td>4:</td><td>10.3</td><td>→</td></tr> <tr><td>5:</td><td>8.3</td><td>→</td></tr> <tr><td>6:</td><td>9.5</td><td>↗</td></tr> <tr><td>Serie</td><td>53</td><td></td></tr> <tr><td>Total</td><td>184</td><td></td></tr> </table>	1:	10.0	←	2:	9.7	↓	3:	7.8	↘	4:	10.3	→	5:	8.3	→	6:	9.5	↗	Serie	53		Total	184	
1:	8.7	←																																													
2:	8.2	↘																																													
3:	10.2	↘																																													
4:	10.7x	↗																																													
5:	10.2	↘																																													
Serie	46																																														
Total	184																																														
1:	10.0	←																																													
2:	9.7	↓																																													
3:	7.8	↘																																													
4:	10.3	→																																													
5:	8.3	→																																													
6:	9.5	↗																																													
Serie	53																																														
Total	184																																														
 <p>5. Serie 5 Skott</p>	<table border="1" style="width:100%; border-collapse: collapse;"> <tr><td>1:</td><td>9.8</td><td>→</td></tr> <tr><td>2:</td><td>9.4</td><td>↗</td></tr> <tr><td>3:</td><td>9.9</td><td>→</td></tr> <tr><td>4:</td><td>8.1</td><td>→</td></tr> <tr><td>5:</td><td>10.6x</td><td>↑</td></tr> <tr><td>Serie</td><td>45</td><td></td></tr> <tr><td>Total</td><td>229</td><td></td></tr> </table>	1:	9.8	→	2:	9.4	↗	3:	9.9	→	4:	8.1	→	5:	10.6x	↑	Serie	45		Total	229		 <p>6. Serie 5 Skott</p> <table border="1" style="width:100%; border-collapse: collapse;"> <tr><td>1:</td><td>9.4</td><td>↙</td></tr> <tr><td>2:</td><td>9.0</td><td>↑</td></tr> <tr><td>3:</td><td>9.5</td><td>↓</td></tr> <tr><td>4:</td><td>7.2</td><td>↓</td></tr> <tr><td>5:</td><td>9.0</td><td>↘</td></tr> <tr><td>Serie</td><td>43</td><td></td></tr> <tr><td>Total</td><td>272</td><td></td></tr> </table>	1:	9.4	↙	2:	9.0	↑	3:	9.5	↓	4:	7.2	↓	5:	9.0	↘	Serie	43		Total	272				
1:	9.8	→																																													
2:	9.4	↗																																													
3:	9.9	→																																													
4:	8.1	→																																													
5:	10.6x	↑																																													
Serie	45																																														
Total	229																																														
1:	9.4	↙																																													
2:	9.0	↑																																													
3:	9.5	↓																																													
4:	7.2	↓																																													
5:	9.0	↘																																													
Serie	43																																														
Total	272																																														
 <p>7. Serie 5 Skott</p>	<table border="1" style="width:100%; border-collapse: collapse;"> <tr><td>1:</td><td>10.3</td><td>↓</td></tr> <tr><td>2:</td><td>8.7</td><td>↓</td></tr> <tr><td>3:</td><td>9.6</td><td>←</td></tr> <tr><td>4:</td><td>9.8</td><td>→</td></tr> <tr><td>5:</td><td>7.4</td><td>→</td></tr> <tr><td>Serie</td><td>43</td><td></td></tr> <tr><td>Total</td><td>315</td><td></td></tr> </table>	1:	10.3	↓	2:	8.7	↓	3:	9.6	←	4:	9.8	→	5:	7.4	→	Serie	43		Total	315																										
1:	10.3	↓																																													
2:	8.7	↓																																													
3:	9.6	←																																													
4:	9.8	→																																													
5:	7.4	→																																													
Serie	43																																														
Total	315																																														

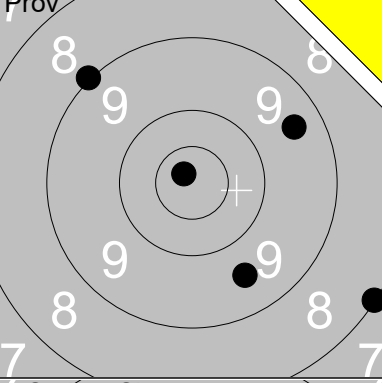
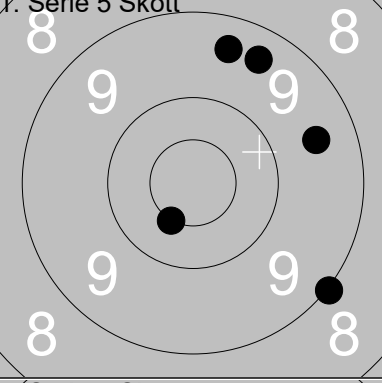
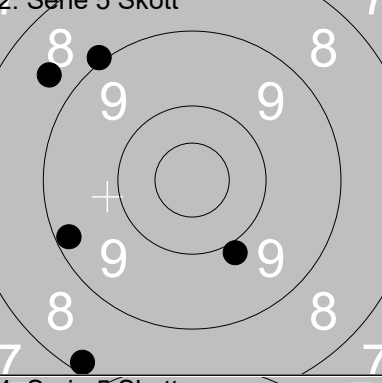
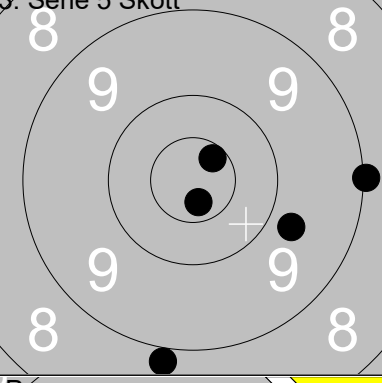
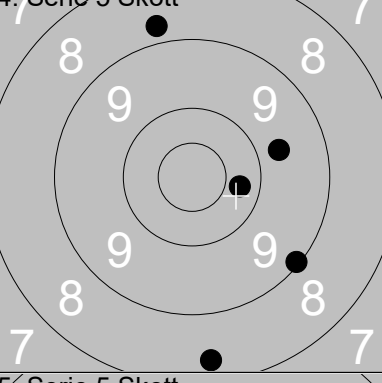
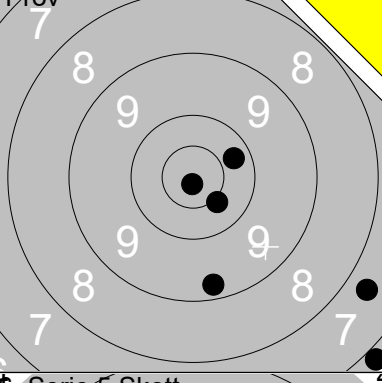
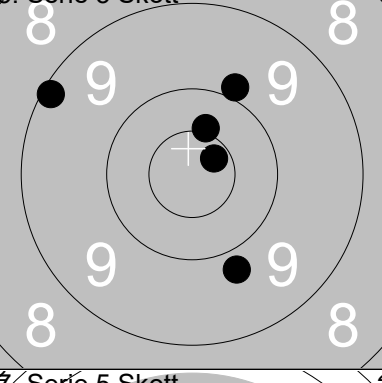
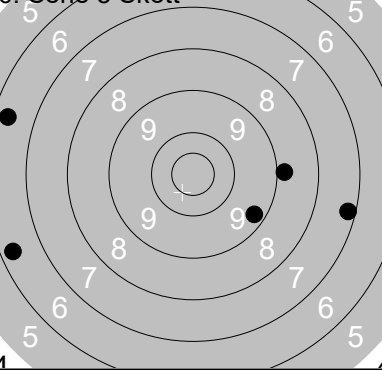
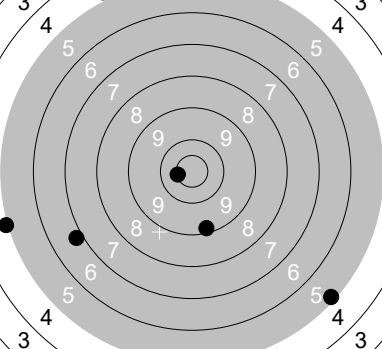
 <p>7</p>	<p>1: 8.0 ↘</p> <p>2: 10.8x ↗</p> <p>3: 9.0 ↗</p> <p>4: 9.4 ↗</p> <p>5: 9.6 ↓</p> <hr/> <p>Serie 45</p> <p>Total 0</p>	 <p>7</p>	<p>1: 9.0 ↘</p> <p>2: 9.4 ↗</p> <p>3: 9.4 ↗</p> <p>4: 9.5 →</p> <p>5: 10.5x ↓</p> <hr/> <p>Serie 46</p> <p>Total 46</p>
 <p>7</p>	<p>1: 8.6 ↗</p> <p>2: 9.0 ↗</p> <p>3: 9.9 ↓</p> <p>4: 8.2 ↓</p> <p>5: 9.2 ←</p> <hr/> <p>Serie 43</p> <p>Total 89</p>	 <p>7</p>	<p>1: 9.0 →</p> <p>2: 10.6x ↗</p> <p>3: 10.7x ↓</p> <p>4: 8.9 ↓</p> <p>5: 9.7 →</p> <hr/> <p>Serie 46</p> <p>Total 135</p>
 <p>7</p>	<p>1: 8.8 ↑</p> <p>2: 9.7 →</p> <p>3: 10.3 →</p> <p>4: 9.1 ↓</p> <p>5: 8.4 ↓</p> <hr/> <p>Serie 44</p> <p>Total 179</p>	 <p>7</p>	<p>1: 9.3 ↓</p> <p>2: 7.7 ↘</p> <p>3: 10.3 →</p> <p>4: 10.4x ↓</p> <p>5: 6.8 ↓</p> <p>6: 10.8x ↓</p> <hr/> <p>Serie 52</p> <p>Total 179</p>
 <p>7</p>	<p>1: 10.7x ↗</p> <p>2: 9.9 ↗</p> <p>3: 9.8 ↓</p> <p>4: 9.1 ↗</p> <p>5: 10.4x ↑</p> <hr/> <p>Serie 47</p> <p>Total 226</p>	 <p>7</p>	<p>1: 8.8 →</p> <p>2: 9.3 ↘</p> <p>3: 7.2 →</p> <p>4: 6.3 ←</p> <p>5: 6.4 ←</p> <hr/> <p>Serie 36</p> <p>Total 262</p>
 <p>7</p>	<p>1: 10.5x ←</p> <p>2: 9.2 ↓</p> <p>3: 5.2 ↓</p> <p>4: 5.0 ←</p> <p>5: 6.8 ←</p> <hr/> <p>Serie 35</p> <p>Total 297</p>		

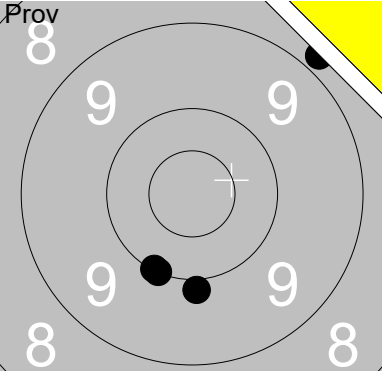
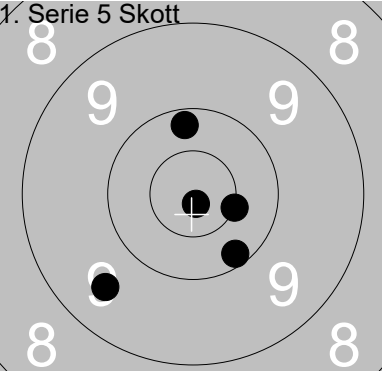
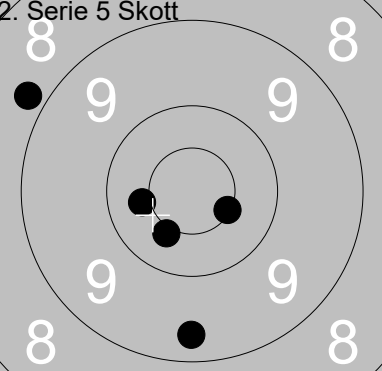
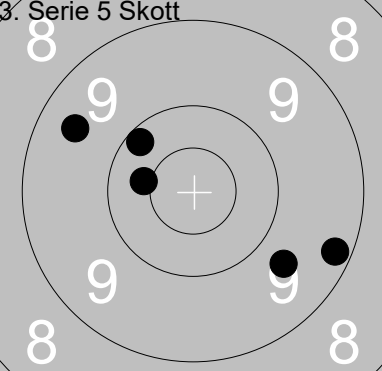
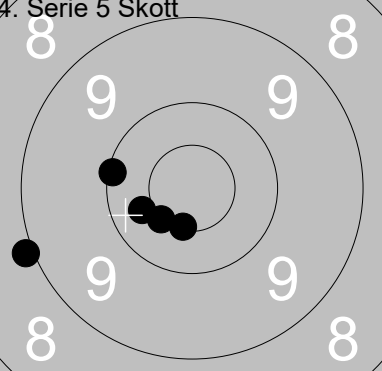
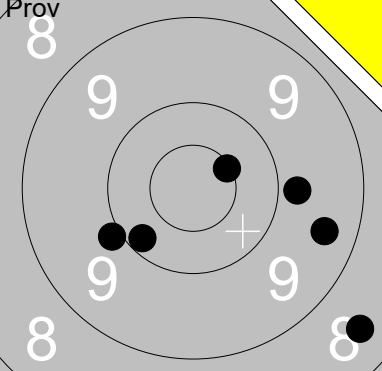
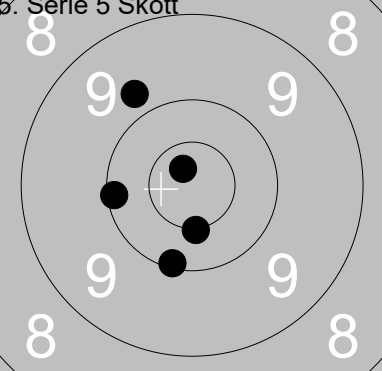
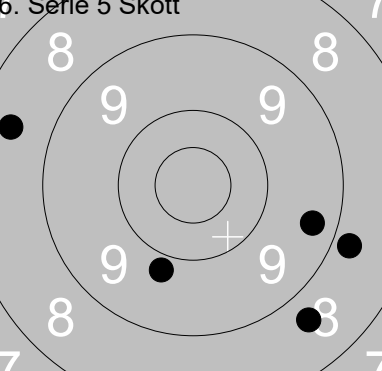
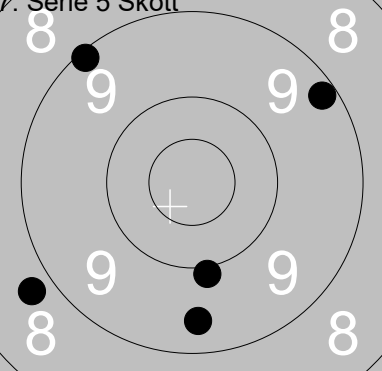
Skjutlag	Tavla	Ulf Ohlsson	
2	12		
Ramselefors	Umeå	C	Vb
07.07.2019	Tavelträffen 2019	Ramselefors SKF	
	1: 8.8 ↗ 2: 8.3 ↗ 3: 10.0 ↓ 4: 10.0 ↓ 5: 9.9 ↓	1. Serie 5 Skott 	1: 10.2 ↑ 2: 10.2 ↓ 3: 9.5 ↙ 4: 10.8x ↓ 5: 10.5x →
Serie 45	Total 0	Serie 49	Total 49
2. Serie 5 Skott 	1: 10.4x ↓ 2: 9.4 ↓ 3: 10.4 ← 4: 10.5x → 5: 8.8 ↗	3. Serie 5 Skott 	1: 9.5 ↗ 2: 9.2 → 3: 9.7 ↘ 4: 10.2 ↗ 5: 10.4 ←
Serie 47	Total 96	Serie 47	Total 143
4. Serie 5 Skott 	1: 10.5x ↓ 2: 10.1 ← 3: 8.9 ← 4: 10.5x ↘ 5: 10.4 ←	Prov 	1: 10.2 ↘ 2: 9.4 → 3: 9.8 → 4: 10.5x ↗ 5: 9.9 ↙ 6: 8.5 ↘
Serie 48	Total 191	Serie 55	Total 191
5. Serie 5 Skott 	1: 10.7x ↗ 2: 9.8 ↗ 3: 10.1 ← 4: 10.5x ↓ 5: 10.1 ↓	6. Serie 5 Skott 	1: 8.5 ← 2: 8.8 → 3: 8.7 ↘ 4: 9.4 → 5: 9.8 ↓
Serie 49	Total 240	Serie 42	Total 282
7. Serie 5 Skott 	1: 9.1 ↗ 2: 9.2 ↗ 3: 8.8 ← 4: 9.9 ↓ 5: 9.4 ↓		
Serie 44	Total 326		

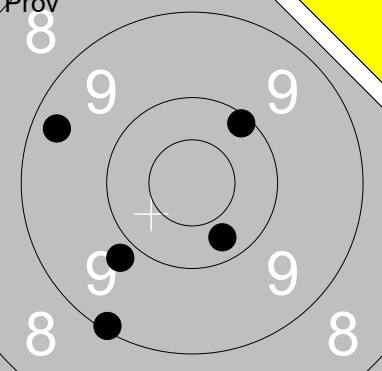
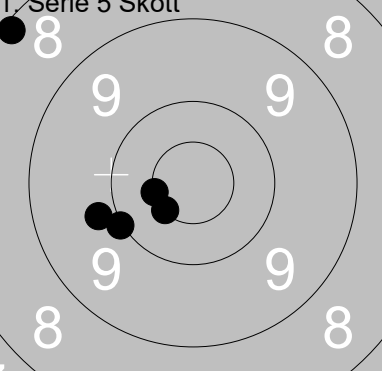
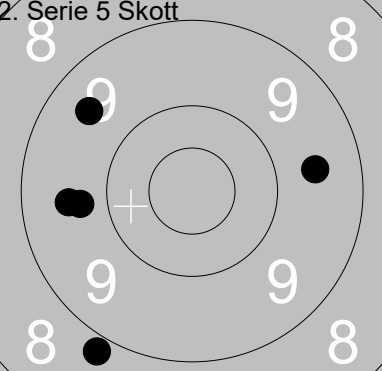
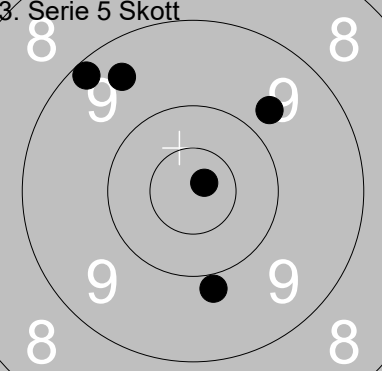
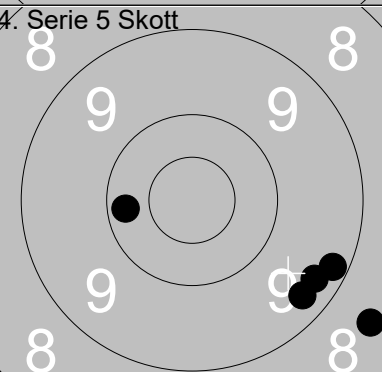
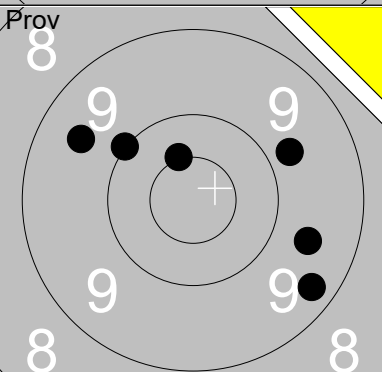
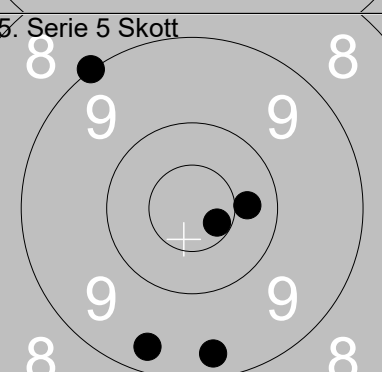
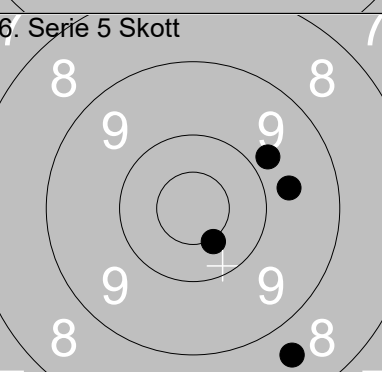
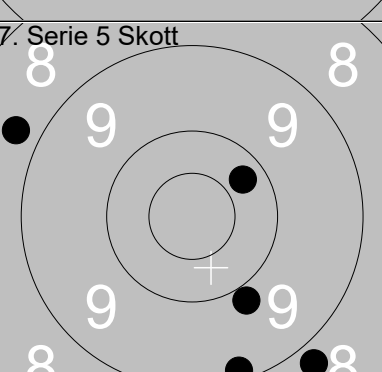
 <p>Prov</p>	<p>1: 10.1 ↗ 2: 10.3 ↓ 3: 9.8 ↙ 4: 9.3 ← 5: 9.1 ↓</p>	 <p>1. Serie 5 Skott</p>	<p>1: 8.1 ↖ 2: 10.5x ← 3: 10.5x ↙ 4: 10.0 ← 5: 9.8 ←</p>
Serie 47	Total 0	Serie 47	Total 47
 <p>2. Serie 5 Skott</p>	<p>1: 9.6 → 2: 9.7 ← 3: 9.5 ↗ 4: 9.6 ← 5: 8.9 ↓</p>	 <p>3. Serie 5 Skott</p>	<p>1: 9.7 ↗ 2: 10.8x ↗ 3: 9.5 ↗ 4: 9.9 ↓ 5: 9.2 ↗</p>
Serie 44	Total 91	Serie 46	Total 137
 <p>4. Serie 5 Skott</p>	<p>1: 9.3 ↓ 2: 9.2 ↓ 3: 9.3 ↓ 4: 10.2 ← 5: 8.5 ↓</p>	 <p>Prov</p>	<p>1: 10.5x ↑ 2: 9.6 → 3: 10.0 ↗ 4: 9.3 ↓ 5: 9.8 → 6: 9.5 ↖</p>
Serie 45	Total 182	Serie 56	Total 182
 <p>5. Serie 5 Skott</p>	<p>1: 9.0 ↖ 2: 10.4 → 3: 10.6x ↙ 4: 9.3 ↓ 5: 9.3 ↓</p>	 <p>6. Serie 5 Skott</p>	<p>1: 9.8 ↗ 2: 8.6 ↓ 3: 10.5x ↙ 4: 9.7 → 5: 7.9 ↓</p>
Serie 47	Total 229	Serie 43	Total 272
 <p>7. Serie 5 Skott</p>	<p>1: 9.9 ↓ 2: 8.7 ↗ 3: 10.3 ↗ 4: 9.2 ↓ 5: 8.8 ↓</p>		
Serie 44	Total 316		

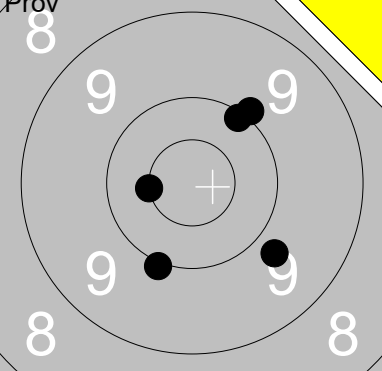
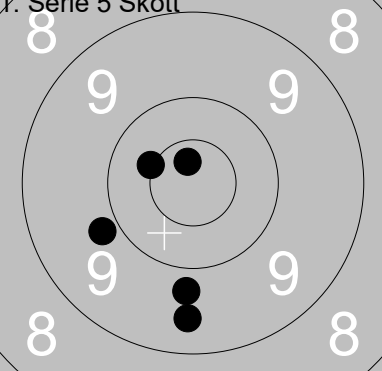
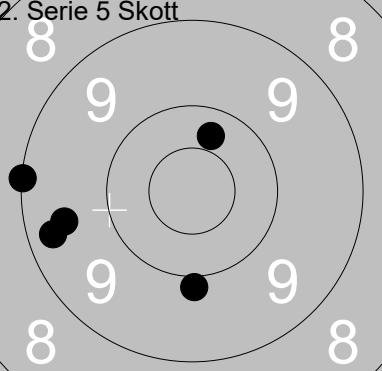
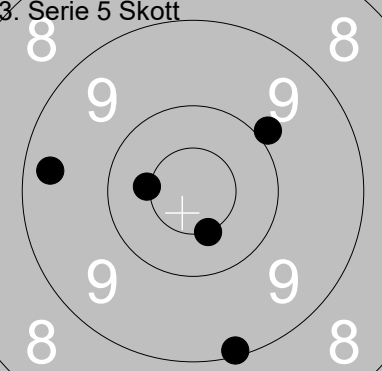
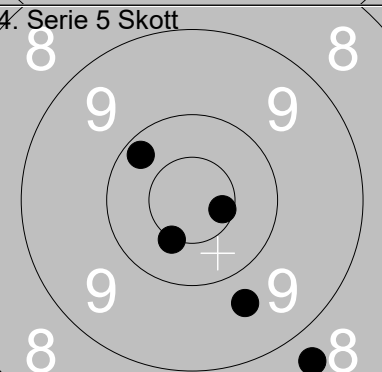
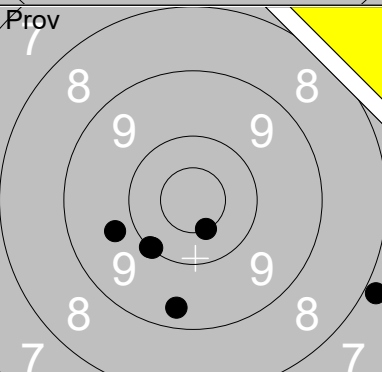
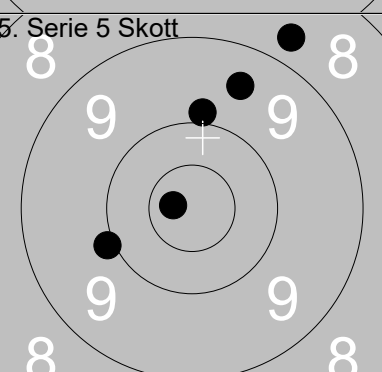
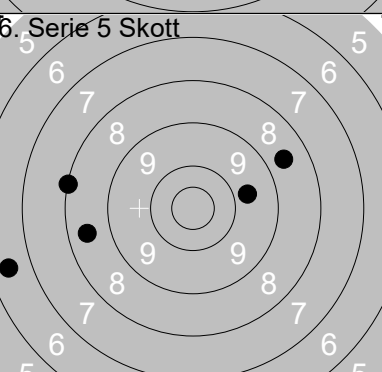
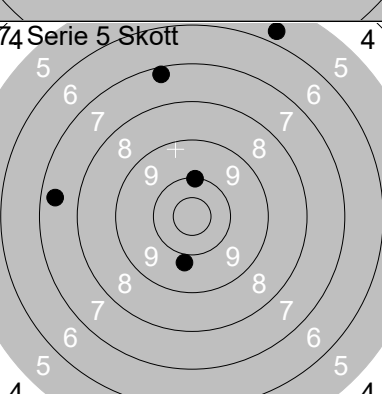
 <p>Prov</p>	<table border="1" style="width:100%; border-collapse: collapse;"> <tr><td>1:</td><td>9.9</td><td>↗</td></tr> <tr><td>2:</td><td>9.8</td><td>↘</td></tr> <tr><td>3:</td><td>10.1</td><td>↗</td></tr> <tr><td>4:</td><td>10.0</td><td>↘</td></tr> <tr><td>5:</td><td>10.5x</td><td>←</td></tr> <tr><td colspan="2">Serie</td><td>48</td></tr> <tr><td colspan="2">Total</td><td>0</td></tr> </table>	1:	9.9	↗	2:	9.8	↘	3:	10.1	↗	4:	10.0	↘	5:	10.5x	←	Serie		48	Total		0	 <p>1. Serie 5 Skott</p>	<table border="1" style="width:100%; border-collapse: collapse;"> <tr><td>1:</td><td>9.4</td><td>↓</td></tr> <tr><td>2:</td><td>9.8</td><td>←</td></tr> <tr><td>3:</td><td>10.5x</td><td>↖</td></tr> <tr><td>4:</td><td>10.7x</td><td>↑</td></tr> <tr><td>5:</td><td>9.8</td><td>↓</td></tr> <tr><td colspan="2">Serie</td><td>47</td></tr> <tr><td colspan="2">Total</td><td>47</td></tr> </table>	1:	9.4	↓	2:	9.8	←	3:	10.5x	↖	4:	10.7x	↑	5:	9.8	↓	Serie		47	Total		47			
1:	9.9	↗																																														
2:	9.8	↘																																														
3:	10.1	↗																																														
4:	10.0	↘																																														
5:	10.5x	←																																														
Serie		48																																														
Total		0																																														
1:	9.4	↓																																														
2:	9.8	←																																														
3:	10.5x	↖																																														
4:	10.7x	↑																																														
5:	9.8	↓																																														
Serie		47																																														
Total		47																																														
 <p>2. Serie 5 Skott</p>	<table border="1" style="width:100%; border-collapse: collapse;"> <tr><td>1:</td><td>9.3</td><td>←</td></tr> <tr><td>2:</td><td>9.5</td><td>←</td></tr> <tr><td>3:</td><td>9.0</td><td>←</td></tr> <tr><td>4:</td><td>9.9</td><td>↓</td></tr> <tr><td>5:</td><td>10.3</td><td>↑</td></tr> <tr><td colspan="2">Serie</td><td>46</td></tr> <tr><td colspan="2">Total</td><td>93</td></tr> </table>	1:	9.3	←	2:	9.5	←	3:	9.0	←	4:	9.9	↓	5:	10.3	↑	Serie		46	Total		93	 <p>3. Serie 5 Skott</p>	<table border="1" style="width:100%; border-collapse: collapse;"> <tr><td>1:</td><td>9.9</td><td>↗</td></tr> <tr><td>2:</td><td>9.1</td><td>↓</td></tr> <tr><td>3:</td><td>9.3</td><td>←</td></tr> <tr><td>4:</td><td>10.4x</td><td>←</td></tr> <tr><td>5:</td><td>10.5x</td><td>↓</td></tr> <tr><td colspan="2">Serie</td><td>47</td></tr> <tr><td colspan="2">Total</td><td>140</td></tr> </table>	1:	9.9	↗	2:	9.1	↓	3:	9.3	←	4:	10.4x	←	5:	10.5x	↓	Serie		47	Total		140			
1:	9.3	←																																														
2:	9.5	←																																														
3:	9.0	←																																														
4:	9.9	↓																																														
5:	10.3	↑																																														
Serie		46																																														
Total		93																																														
1:	9.9	↗																																														
2:	9.1	↓																																														
3:	9.3	←																																														
4:	10.4x	←																																														
5:	10.5x	↓																																														
Serie		47																																														
Total		140																																														
 <p>4. Serie 5 Skott</p>	<table border="1" style="width:100%; border-collapse: collapse;"> <tr><td>1:</td><td>10.6x</td><td>→</td></tr> <tr><td>2:</td><td>10.2</td><td>↗</td></tr> <tr><td>3:</td><td>9.7</td><td>↘</td></tr> <tr><td>4:</td><td>10.5x</td><td>↘</td></tr> <tr><td>5:</td><td>8.7</td><td>↘</td></tr> <tr><td colspan="2">Serie</td><td>47</td></tr> <tr><td colspan="2">Total</td><td>187</td></tr> </table>	1:	10.6x	→	2:	10.2	↗	3:	9.7	↘	4:	10.5x	↘	5:	8.7	↘	Serie		47	Total		187	 <p>Prov</p>	<table border="1" style="width:100%; border-collapse: collapse;"> <tr><td>1:</td><td>10.5x</td><td>↓</td></tr> <tr><td>2:</td><td>10.1</td><td>↘</td></tr> <tr><td>3:</td><td>9.4</td><td>↓</td></tr> <tr><td>4:</td><td>10.0</td><td>↘</td></tr> <tr><td>5:</td><td>7.9</td><td>→</td></tr> <tr><td>6:</td><td>9.7</td><td>←</td></tr> <tr><td colspan="2">Serie</td><td>55</td></tr> <tr><td colspan="2">Total</td><td>187</td></tr> </table>	1:	10.5x	↓	2:	10.1	↘	3:	9.4	↓	4:	10.0	↘	5:	7.9	→	6:	9.7	←	Serie		55	Total		187
1:	10.6x	→																																														
2:	10.2	↗																																														
3:	9.7	↘																																														
4:	10.5x	↘																																														
5:	8.7	↘																																														
Serie		47																																														
Total		187																																														
1:	10.5x	↓																																														
2:	10.1	↘																																														
3:	9.4	↓																																														
4:	10.0	↘																																														
5:	7.9	→																																														
6:	9.7	←																																														
Serie		55																																														
Total		187																																														
 <p>5. Serie 5 Skott</p>	<table border="1" style="width:100%; border-collapse: collapse;"> <tr><td>1:</td><td>9.5</td><td>↗</td></tr> <tr><td>2:</td><td>9.9</td><td>←</td></tr> <tr><td>3:</td><td>10.7x</td><td>←</td></tr> <tr><td>4:</td><td>8.7</td><td>↗</td></tr> <tr><td>5:</td><td>9.9</td><td>↑</td></tr> <tr><td colspan="2">Serie</td><td>45</td></tr> <tr><td colspan="2">Total</td><td>232</td></tr> </table>	1:	9.5	↗	2:	9.9	←	3:	10.7x	←	4:	8.7	↗	5:	9.9	↑	Serie		45	Total		232	 <p>6. Serie 5 Skott</p>	<table border="1" style="width:100%; border-collapse: collapse;"> <tr><td>1:</td><td>8.6</td><td>↗</td></tr> <tr><td>2:</td><td>8.1</td><td>←</td></tr> <tr><td>3:</td><td>6.5</td><td>←</td></tr> <tr><td>4:</td><td>9.7</td><td>→</td></tr> <tr><td>5:</td><td>8.5</td><td>←</td></tr> <tr><td colspan="2">Serie</td><td>39</td></tr> <tr><td colspan="2">Total</td><td>271</td></tr> </table>	1:	8.6	↗	2:	8.1	←	3:	6.5	←	4:	9.7	→	5:	8.5	←	Serie		39	Total		271			
1:	9.5	↗																																														
2:	9.9	←																																														
3:	10.7x	←																																														
4:	8.7	↗																																														
5:	9.9	↑																																														
Serie		45																																														
Total		232																																														
1:	8.6	↗																																														
2:	8.1	←																																														
3:	6.5	←																																														
4:	9.7	→																																														
5:	8.5	←																																														
Serie		39																																														
Total		271																																														
 <p>7. Serie 5 Skott</p>	<table border="1" style="width:100%; border-collapse: collapse;"> <tr><td>1:</td><td>5.7</td><td>↗</td></tr> <tr><td>2:</td><td>9.8</td><td>↓</td></tr> <tr><td>3:</td><td>7.2</td><td>↑</td></tr> <tr><td>4:</td><td>10.0</td><td>↑</td></tr> <tr><td>5:</td><td>7.4</td><td>←</td></tr> <tr><td colspan="2">Serie</td><td>38</td></tr> <tr><td colspan="2">Total</td><td>309</td></tr> </table>	1:	5.7	↗	2:	9.8	↓	3:	7.2	↑	4:	10.0	↑	5:	7.4	←	Serie		38	Total		309																										
1:	5.7	↗																																														
2:	9.8	↓																																														
3:	7.2	↑																																														
4:	10.0	↑																																														
5:	7.4	←																																														
Serie		38																																														
Total		309																																														

Skjutlag	Tavla	Rebecka Andersson	
2	16	Loos	B Gä
07.07.2019	Tavelträffen 2019	Ramselefors SKF	
Prov 	1: 8.0 ↑ 2: 9.5 ↗ 3: 8.8 ↖ 4: 9.6 ↗ 5: 10.0 ↑ Serie 44 Total 0	1. Serie 5 Skott 	1: 10.8x ↖ 2: 10.8x ↘ 3: 10.3 ↗ 4: 9.0 ↑ 5: 9.0 ↖ Serie 48 Total 48
2. Serie 5 Skott 	1: 10.0 ↓ 2: 10.3 ↗ 3: 10.3 ↓ 4: 9.9 ↗ 5: 10.1 ↗ Serie 49 Total 97	3. Serie 5 Skott 	1: 10.1 → 2: 9.3 ↓ 3: 8.5 ↓ 4: 7.9 ↓ 5: 8.6 ↓ Serie 42 Total 139
4. Serie 5 Skott 	1: 8.8 ↗ 2: 10.4 ↓ 3: 9.7 ↗ 4: 9.1 ↓ 5: 9.9 ↓ Serie 45 Total 184	Prov 	1: 10.4 ↓ 2: 9.6 ↓ 3: 10.0 → 4: 9.9 ↗ 5: 9.2 → 6: 9.8 → Serie 56 Total 184
5. Serie 5 Skott 	1: 10.0 ↘ 2: 10.3 ↘ 3: 9.6 ↖ 4: 10.5x ↓ 5: 10.1 ↓ Serie 49 Total 233	6. Serie 5 Skott 	1: 9.7 → 2: 9.1 ↓ 3: 10.2 → 4: 10.4 ↘ 5: 9.6 ↓ Serie 47 Total 280
7. Serie 5 Skott 	1: 5.9 ↑ 2: 9.1 → 3: 6.8 ↑ 4: 7.8 ↖ 5: 7.8 ↑ Serie 34 Total 314		

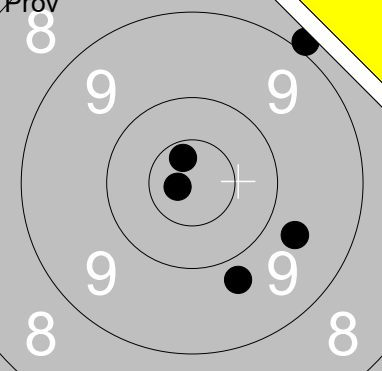
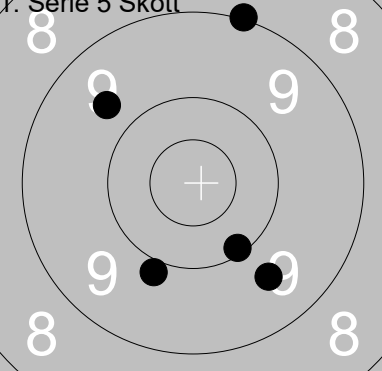
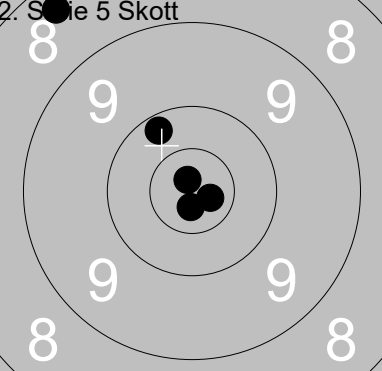
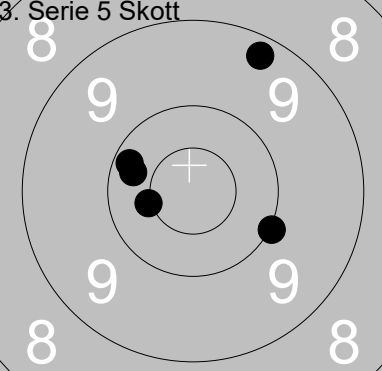
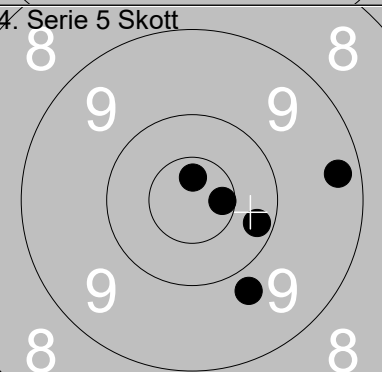
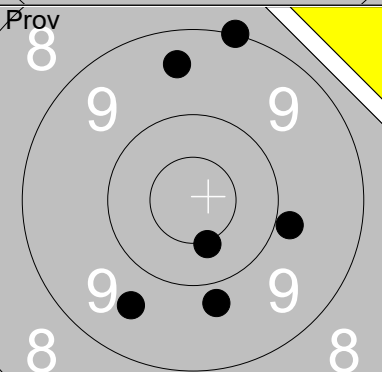
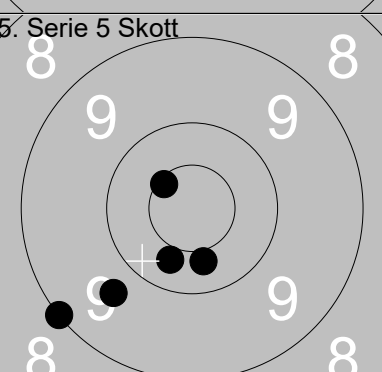
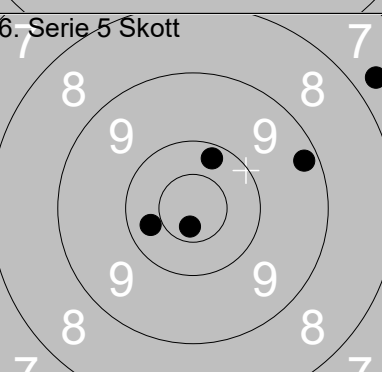
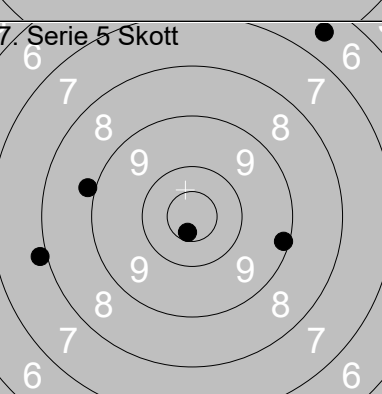
 <p>Prov</p>	<p>1: 8.9 ↗ 2: 10.7x ↑ 3: 10.8x ← 4: 9.7 → 5: 9.8 ↓</p>	 <p>1. Serie 5 Skott</p>	<p>1: 9.0 ↑ 2: 9.6 ↓ 3: 10.1 ↓ 4: 9.9 ↓ 5: 9.7 ↗</p>
	<p>Serie 46 Total 0</p>		<p>Serie 46 Total 46</p>
 <p>2. Serie 5 Skott</p>	<p>1: 8.3 ↗ 2: 10.2 ↗ 3: 10.8x ↓ 4: 10.8x ↑ 5: 10.7x →</p>	 <p>3. Serie 5 Skott</p>	<p>1: 9.3 ↑ 2: 10.3 ← 3: 10.2 ↗ 4: 10.4x ← 5: 10.0 ↓</p>
	<p>Serie 48 Total 94</p>		<p>Serie 49 Total 143</p>
 <p>4. Serie 5 Skott</p>	<p>1: 10.2 → 2: 10.6x → 3: 9.3 → 4: 10.7x ↑ 5: 9.8 ↓</p>	 <p>Prov</p>	<p>1: 9.0 ↑ 2: 9.4 ↑ 3: 10.4x ↓ 4: 9.6 ↓ 5: 9.9 → 6: 9.8 ↓</p>
	<p>Serie 48 Total 191</p>		<p>Serie 55 Total 191</p>
 <p>5. Serie 5 Skott</p>	<p>1: 9.0 ↙ 2: 10.4 ↓ 3: 10.3 ↓ 4: 10.6x ↗ 5: 9.7 ↙</p>	 <p>6. Serie 5 Skott</p>	<p>1: 7.7 ↗ 2: 10.2 ↑ 3: 10.3 ← 4: 10.7x ↓ 5: 9.2 →</p>
	<p>Serie 48 Total 239</p>		<p>Serie 46 Total 285</p>
 <p>7. Serie 5 Skott</p>	<p>1: 6.5 ↗ 2: 9.1 → 3: 8.9 ← 4: 10.6x ↓ 5: 7.9 ←</p>		
	<p>Serie 40 Total 325</p>		

Skjutlag	Tavla	Felicia Andersson	
2	18		
Ramselefors	Loos	B	Gä
07.07.2019	Tavelträffen 2019	Ramselefors SKF	
	1: 9.5 ↑ 2: 9.6 ↗ 3: 9.6 ↖ 4: 7.5 ← 5: 10.8x ↑	1. Serie 5 Skott 	1: 10.3 ↓ 2: 10.5x ↖ 3: 10.4 ↓ 4: 9.2 ↓ 5: 9.9 ←
Serie 44	Total 0	Serie 48	Total 48
2. Serie 5 Skott 	1: 10.1 ← 2: 8.6 ↗ 3: 6.6 ↓ 4: 9.8 ← 5: 10.4x ↓	3. Serie 5 Skott 	1: 7.5 ↑ 2: 10.2 ↓ 3: 9.8 ↓ 4: 9.0 ← 5: 6.1 →
Serie 43	Total 91	Serie 41	Total 132
4. Serie 5 Skott 	1: 8.3 ↗ 2: 9.6 ↓ 3: 8.1 ↘ 4: 9.2 → 5: 9.5 →	4. Prov 	1: 9.9 ↗ 2: 6.6 ↖ 3: 7.1 ← 4: 6.8 ↑ 5: 8.0 ← 6: 4.8 ←
Serie 43	Total 175	Serie 40	Total 175
5. Serie 5 Skott 	1: 10.4x ↑ 2: 9.3 ↑ 3: 10.7x → 4: 10.2 ↑ 5: 8.9 ↖	6. Serie 5 Skott 	1: 10.7x ↓ 2: 8.1 ↖ 3: 9.4 ↓ 4: 9.5 ← 5: 7.8 ↓
Serie 47	Total 222	Serie 43	Total 265
7. Serie 5 Skott 	1: 1.0 ↓ 2: 6.1 → 3: 8.2 ↓ 4: 5.2 ← 5: 9.3 ↖		
Serie 29	Total 294		

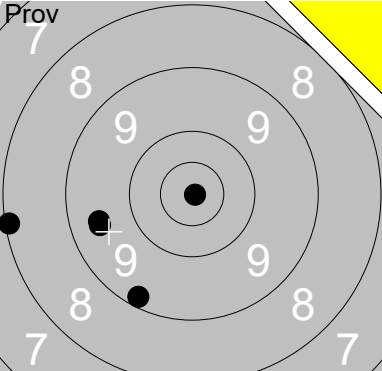
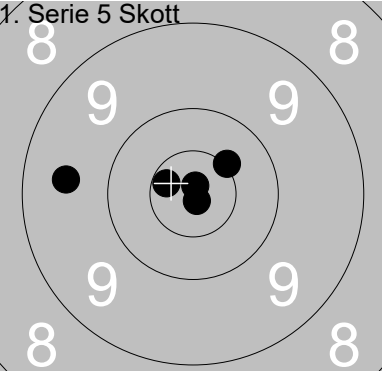
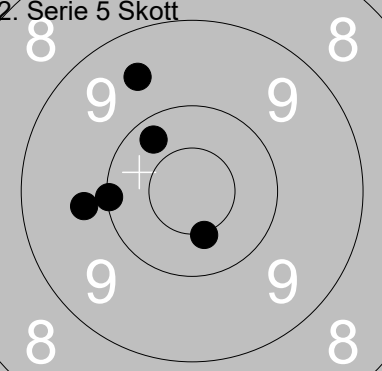
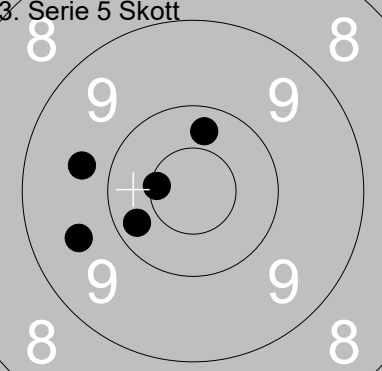
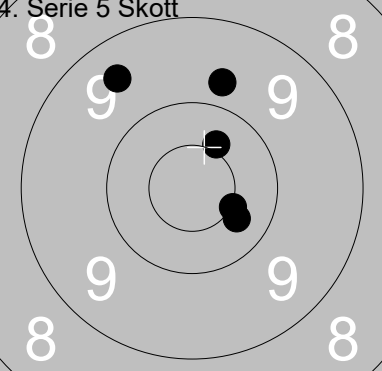
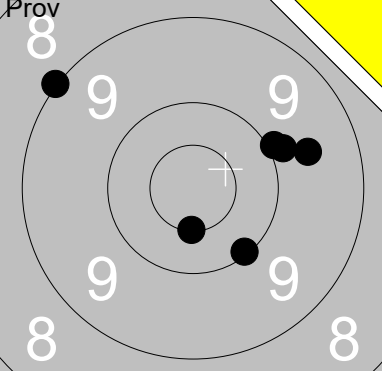
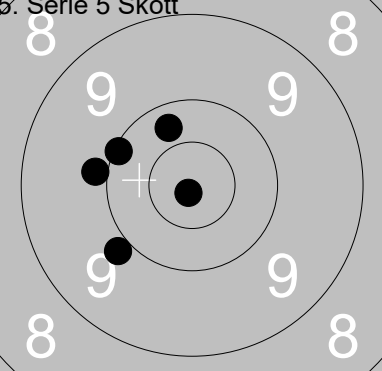
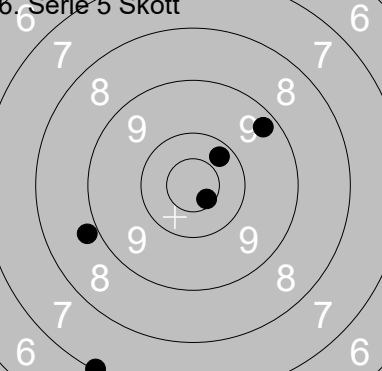
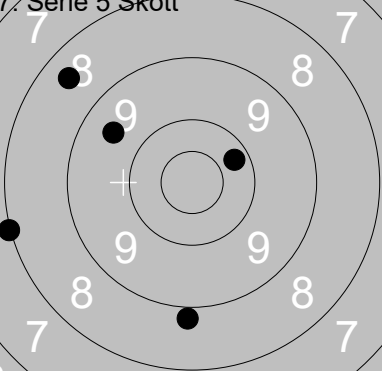
Skjutlag	Tavla	Henrik Olsson	
2	19	Ramselefors	Öved-Östraby
07.07.2019	Tavelträffen 2019	Ramselefors SKF	
Prov 	1: 9.5 ← 2: 8.1 ← 3: 9.5 ← 4: 9.2 ↓ 5: 10.9x → Serie 45 Total 0	1. Serie 5 Skott 	1: 10.9x ↑ 2: 10.6x ← 3: 9.5 ← 4: 10.9x ↓ 5: 10.5x ↗ Serie 49 Total 49
2. Serie 5 Skott 	1: 9.5 ↑ 2: 10.0 ← 3: 9.8 ← 4: 10.3 ↗ 5: 10.5x ↓ Serie 48 Total 97	3. Serie 5 Skott 	1: 10.3 ← 2: 9.6 ← 3: 10.3 ↑ 4: 10.6x ← 5: 9.7 ← Serie 48 Total 145
4. Serie 5 Skott 	1: 10.4 → 2: 9.7 ↑ 3: 9.5 ↗ 4: 10.4 ↗ 5: 10.5x → Serie 48 Total 193	Prov 	1: 10.0 ↗ 2: 9.9 → 3: 10.5x ↓ 4: 10.1 ↓ 5: 9.0 ↗ 6: 9.6 → Serie 57 Total 193
5. Serie 5 Skott 	1: 10.9x ↓ 2: 9.9 ← 3: 10.1 ← 4: 10.3 ↑ 5: 9.9 ← Serie 48 Total 241	6. Serie 5 Skott 	1: 9.3 ↗ 2: 10.3 ↗ 3: 8.8 ← 4: 7.1 ↓ 5: 10.6x ↓ Serie 44 Total 285
7. Serie 5 Skott 	1: 8.4 ↗ 2: 8.9 ↓ 3: 10.2 ↗ 4: 9.5 ↗ 5: 8.0 ← Serie 43 Total 328		

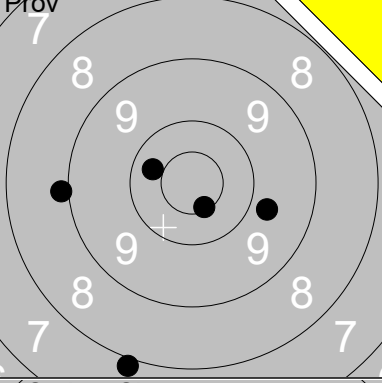
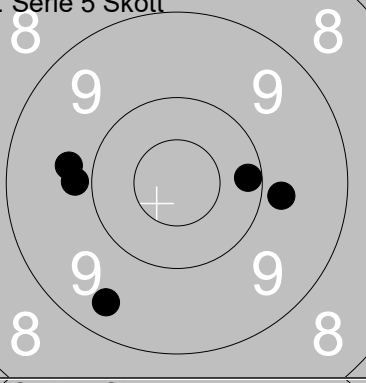
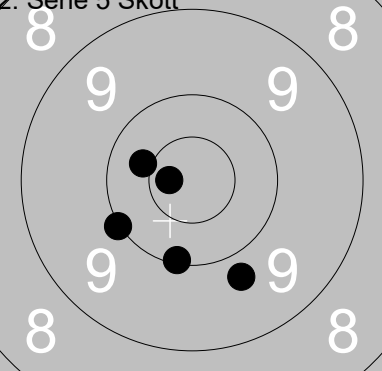
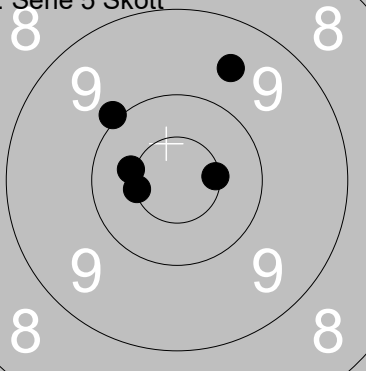
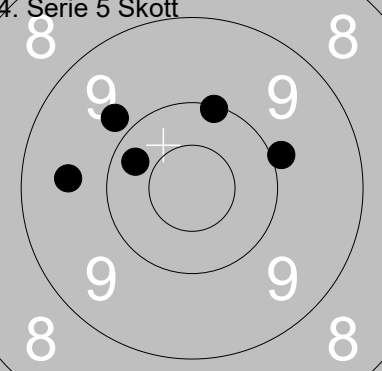
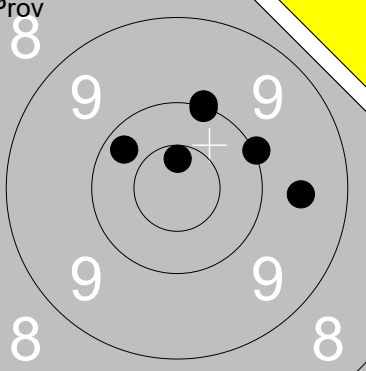
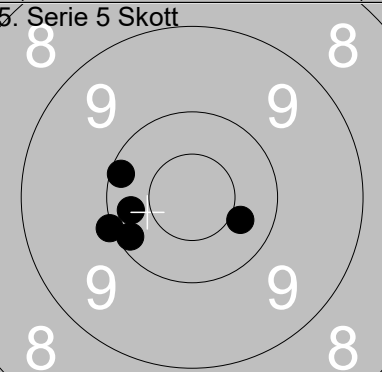
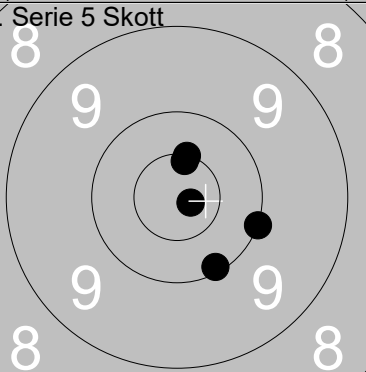
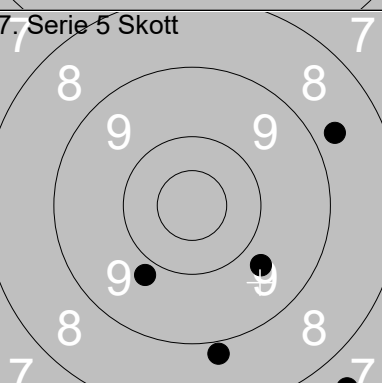
Prov 	1. Serie 5 Skott 	1: 7.9 ↘ 2: 8.9 ← 3: 9.7 → 4: 10.3 ← 5: 10.5x ↓	1: 10.2 → 2: 9.4 ↓ 3: 9.8 ← 4: 9.8 ← 5: 9.8 →
Serie 44 Total 0	Serie 46 Total 46	Serie 44 Total 0	Serie 46 Total 46
2. Serie 5 Skott 	3. Serie 5 Skott 	1: 10.7x ← 2: 10.1 ↓ 3: 10.0 ← 4: 9.8 ↓ 5: 10.4 ←	1: 10.5x → 2: 10.4x ← 3: 10.0 ↗ 4: 9.6 ↗ 5: 10.5x ←
Serie 49 Total 95	Serie 49 Total 144	Serie 49 Total 95	Serie 49 Total 144
4. Serie 5 Skott 	Prov 	1: 9.9 → 2: 10.3 ↗ 3: 9.6 ← 4: 10.1 ↗ 5: 9.8 ↗	1: 10.0 ↗ 2: 10.2 ↗ 3: 10.0 ↗ 4: 9.6 → 5: 10.6x ↗ 6: 10.0 ↗
Serie 47 Total 191	Serie 59 Total 191	Serie 47 Total 191	Serie 59 Total 191
5. Serie 5 Skott 	6. Serie 5 Skott 	1: 10.3 ← 2: 10.1 ← 3: 10.4 → 4: 10.2 ← 5: 10.0 ←	1: 10.5x ↗ 2: 10.1 ↓ 3: 10.8x → 4: 10.0 → 5: 10.6x ↗
Serie 50 Total 241	Serie 50 Total 291	Serie 50 Total 241	Serie 50 Total 291
7. Serie 5 Skott 			
Serie 41 Total 332			

Skjutlag	Tavla	Berit Olsson	
2	22	Ramselefors	Öved-Östraby
07.07.2019	Tavelträffen 2019	Ramselefors SKF	
	1: 10.0 ↙ 2: 9.9 ↓ 3: 9.9 → 4: 10.1 ↗ 5: 10.2 ↓		1: 10.4 ← 2: 10.2 ↑ 3: 10.2 → 4: 10.6x ↑ 5: 10.6x ↓
Serie 48	Total 0	Serie 50	Total 50
	1: 10.7x ↑ 2: 10.4 ← 3: 10.4 ↓ 4: 10.0 ↑ 5: 10.2 ↗		1: 10.0 ↓ 2: 10.7x → 3: 9.6 ← 4: 10.7x ↗ 5: 9.6 →
Serie 50	Total 100	Serie 48	Total 148
	1: 9.9 ↓ 2: 10.3 ← 3: 10.5x ↓ 4: 9.8 ↓ 5: 10.3 ↗		1: 10.5x ↙ 2: 10.6x ↓ 3: 10.8x ↗ 4: 10.2 ← 5: 8.9 → 6: 9.0 ↓
Serie 48	Total 196	Serie 57	Total 196
	1: 9.7 ↙ 2: 10.1 ↓ 3: 10.3 ↓ 4: 10.3 ↑ 5: 10.3 →		1: 10.0 ↗ 2: 9.6 ↓ 3: 10.0 ↘ 4: 10.0 → 5: 9.4 ←
Serie 49	Total 245	Serie 48	Total 293
	1: 10.6x ↑ 2: 9.4 → 3: 9.5 ↗ 4: 7.1 → 5: 10.2 ↓		
Serie 45	Total 338		

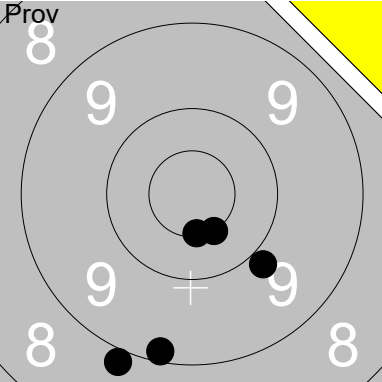
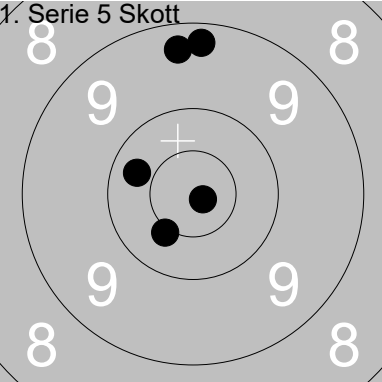
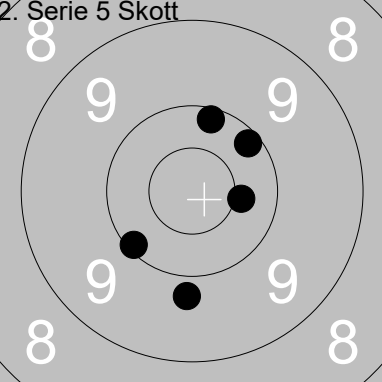
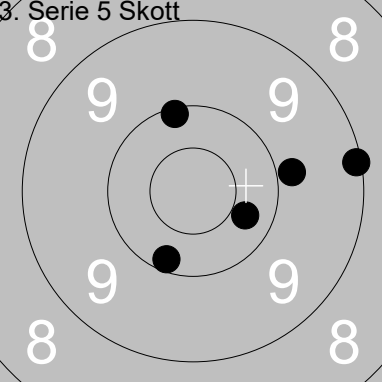
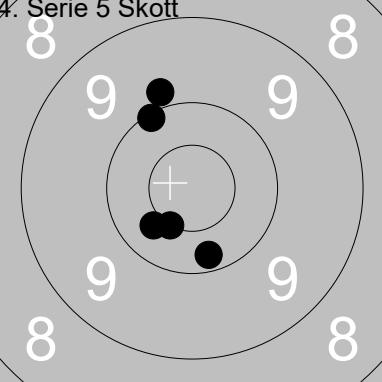
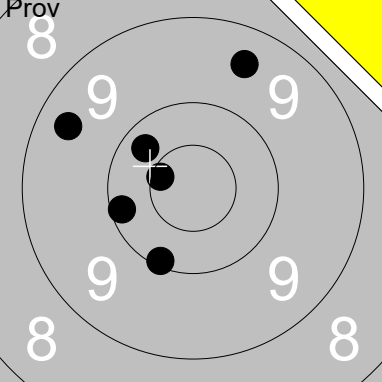
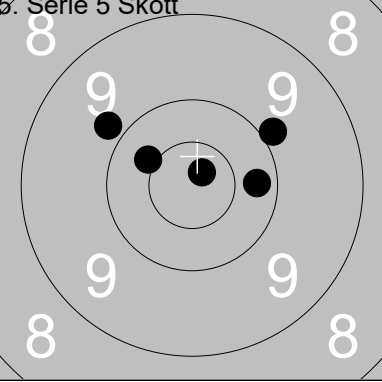
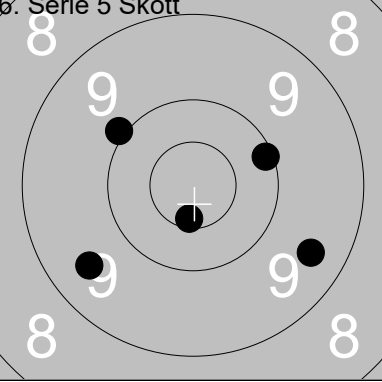
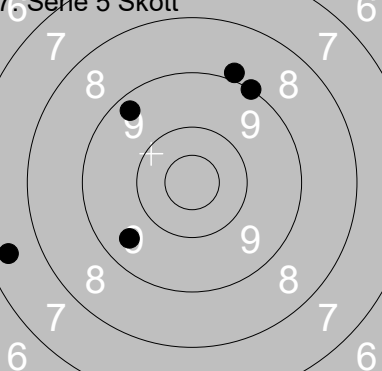

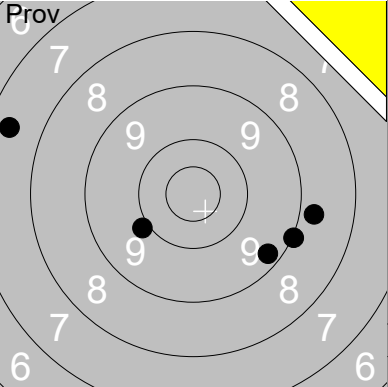
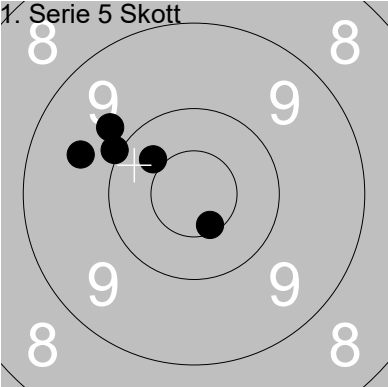
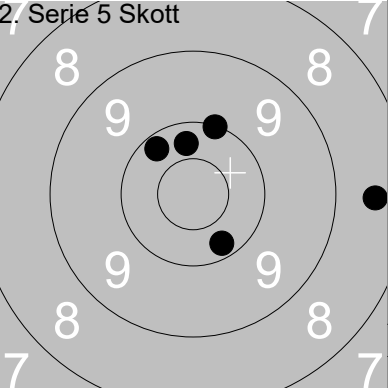
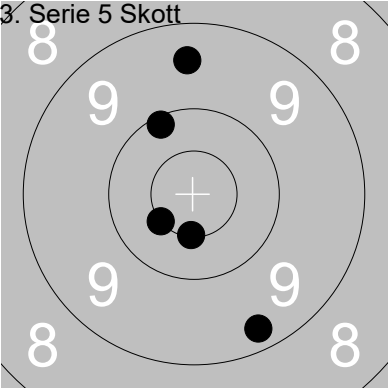
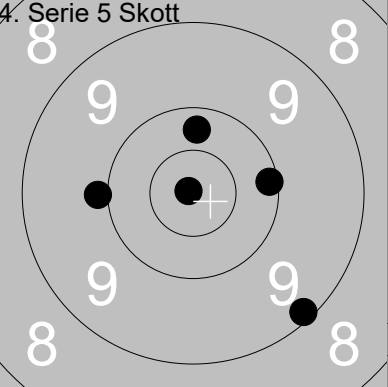
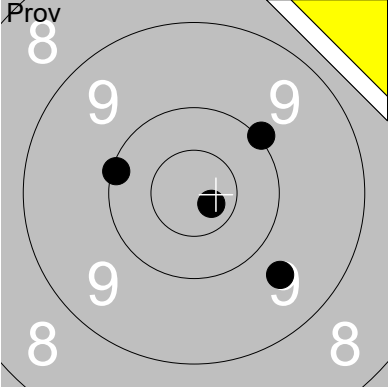
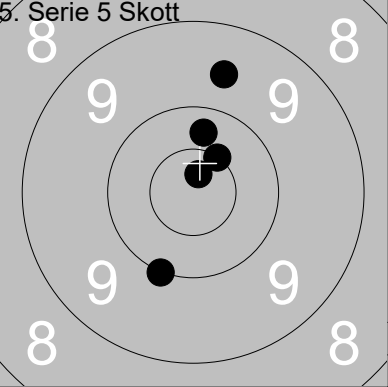
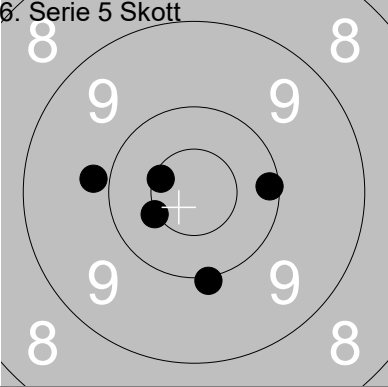
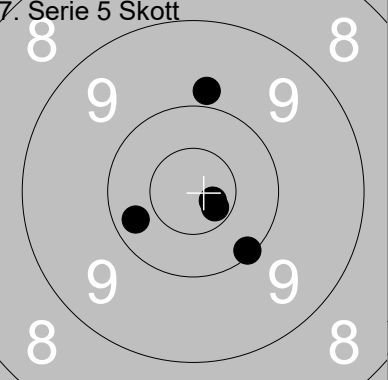

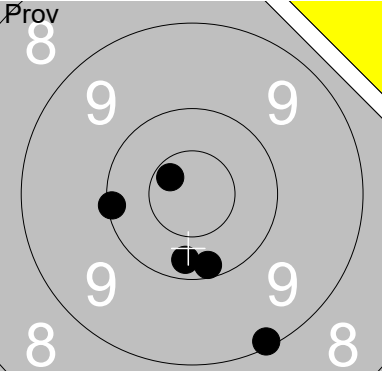
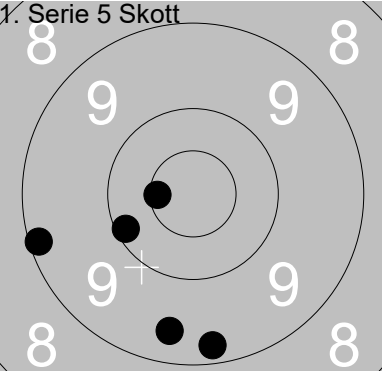
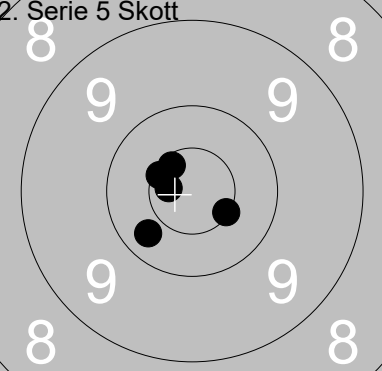
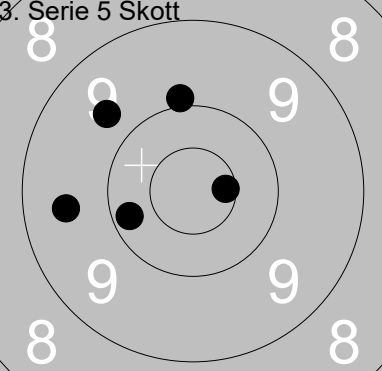
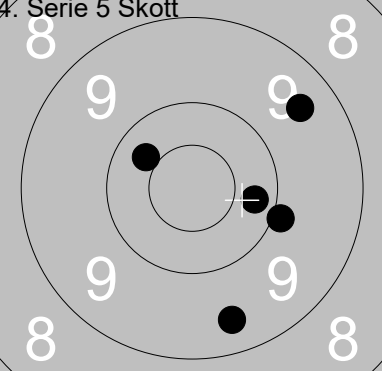
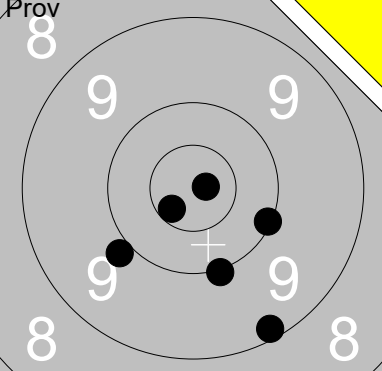
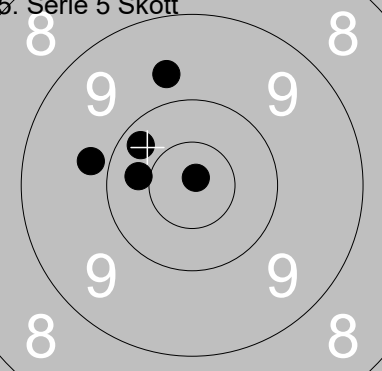
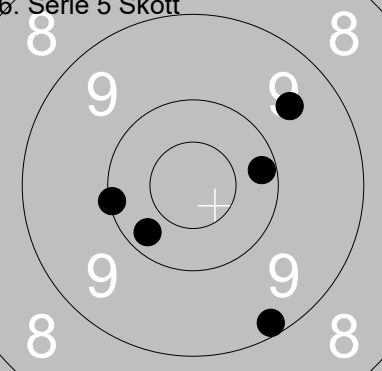
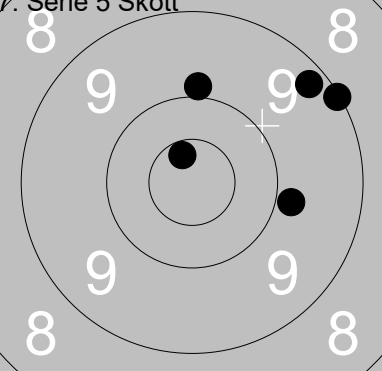
Skjutlag	Tavla	Bengt Jansson	
2	23	Ramselefors	Söderala
07.07.2019	Tavelträffen 2019	Ramselefors SKF	
Prov		1. Serie 5 Skott	
	1: 10.5x ↓ 2: 8.9 ↓ 3: 9.2 ↓ 4: 10.5x ↓ 5: 9.9 ↓		1: 10.3 ← 2: 9.3 ↑ 3: 9.3 ↑ 4: 10.8x → 5: 10.4x ↓
	Serie 46 Total 0		Serie 48 Total 48
	1: 10.1 ← 2: 9.8 ↓ 3: 10.4x → 4: 10.2 ↗ 5: 10.1 ↑		1: 10.3 → 2: 10.1 ↑ 3: 10.2 ↓ 4: 9.1 → 5: 9.9 →
	Serie 49 Total 97		Serie 48 Total 145
	1: 10.4 ← 2: 10.1 ↗ 3: 9.8 ↗ 4: 10.2 ↓ 5: 10.5x ↓		1: 10.1 ← 2: 9.4 ← 3: 10.3 ↗ 4: 10.6x ← 5: 10.1 ↓ 6: 9.5 ↑
	Serie 49 Total 194		Serie 58 Total 194
	1: 9.8 ← 2: 10.2 → 3: 10.4 ← 4: 10.8x ↗ 5: 9.9 ↗		1: 10.1 → 2: 9.4 → 3: 9.5 ← 4: 10.0 ← 5: 10.6x ↓
	Serie 48 Total 242		Serie 48 Total 290
	1: 7.4 ← 2: 8.9 ↑ 3: 9.5 ← 4: 9.3 ↗ 5: 9.0 ↗		
	Serie 42 Total 332		

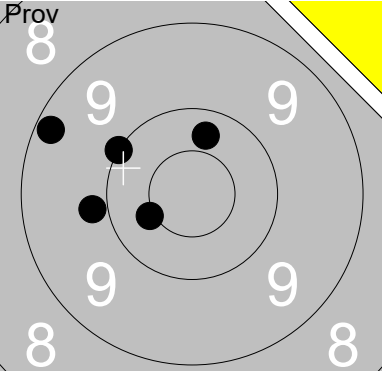
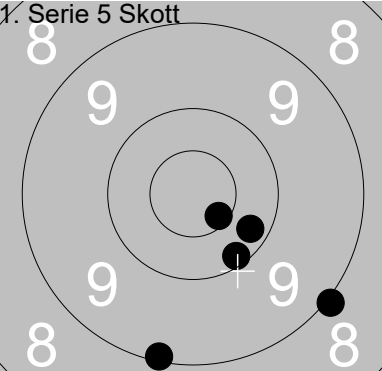
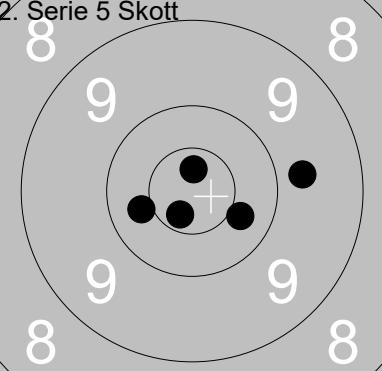
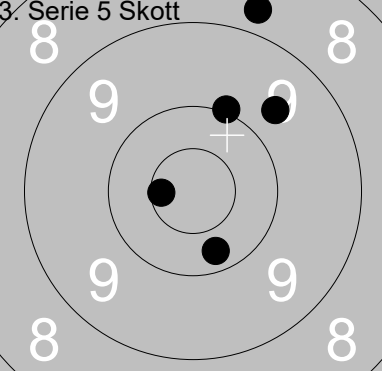
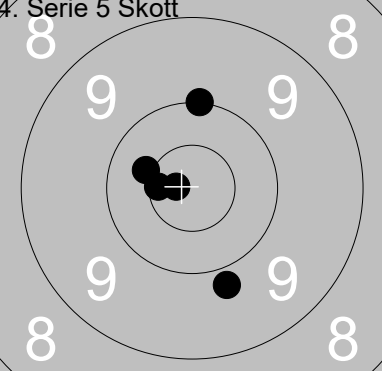
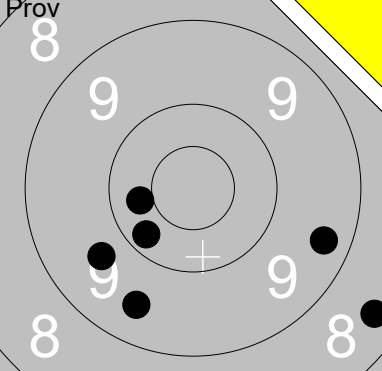
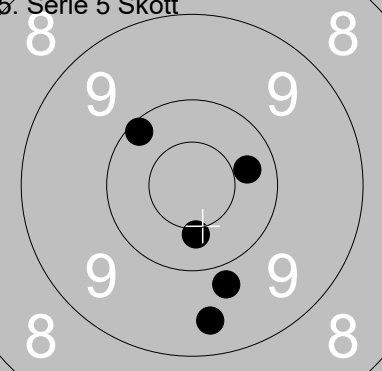
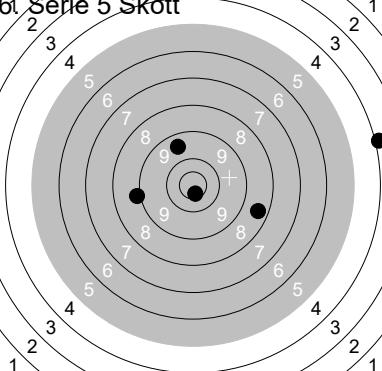
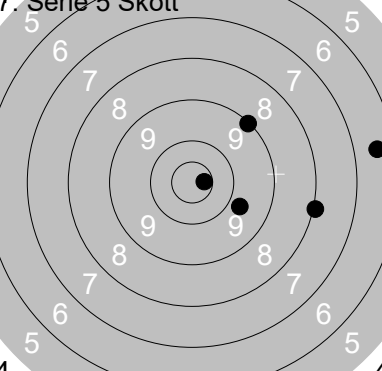
Skjutlag	Tavla	Åke Arbrink		D	St
3	1	Ramselefors	Rosersberg		
07.07.2019	Tavelträffen 2019	Ramselefors SKF			
Prov		1. Serie 5 Skott			
	1: 8.8 → 2: 9.0 → 3: 9.3 ↓ 4: 7.4 ↖ 5: 9.9 ↙		1: 9.6 ↖ 2: 10.0 ↗ 3: 10.6x ↓ 4: 10.4 ↗ 5: 9.8 ↗		
	Serie 42 Total 0		Serie 48 Total 48		
2. Serie 5 Skott		3. Serie 5 Skott			
	1: 10.3 ↑ 2: 8.5 → 3: 10.0 ↑ 4: 10.2 ↓ 5: 10.2 ↗		1: 9.5 ↑ 2: 9.3 ↓ 3: 10.1 ↗ 4: 10.5x ↓ 5: 10.5x ↙		
	Serie 48 Total 96		Serie 48 Total 144		
4. Serie 5 Skott		Prov			
	1: 9.9 ← 2: 9.1 ↓ 3: 10.3 ↑ 4: 10.9x ↖ 5: 10.1 →		1: 10.0 ↗ 2: 9.6 ↓ 3: 10.7x ↓ 4: 10.1 ↖		
	Serie 48 Total 192		Serie 39 Total 192		
5. Serie 5 Skott		6. Serie 5 Skott			
	1: 9.6 ↑ 2: 10.3 ↑ 3: 10.7x ↑ 4: 10.0 ↓ 5: 10.5x ↗		1: 10.6x ↖ 2: 10.0 ↓ 3: 10.1 → 4: 10.5x ↖ 5: 9.8 ←		
	Serie 49 Total 241		Serie 49 Total 290		
7. Serie 5 Skott					
	1: 10.7x → 2: 10.1 ↓ 3: 9.8 ↑ 4: 10.7x ↓ 5: 10.3 ↖				
	Serie 49 Total 339				

Skjutlag 3	Tavla 3	Margaretha Ottosson			
Ramselefors		Bromma-Solna		C	St
07.07.2019		Tavelträffen 2019		Ramselefors SKF	
	1: 10.6x ↖ 2: 10.2 ↓ 3: 9.1 ↓ 4: 10.1 ← 5: 10.2 ↓	1. Serie 5 Skott 	1: 9.4 ↓ 2: 9.1 ← 3: 10.6x ← 4: 10.1 ← 5: 9.2 ↓	Serie	49
Serie		49		Serie	47
Total		0		Total	47
	1: 10.6x ↖ 2: 10.3 ↙ 3: 10.6x ↗ 4: 10.5x ↘ 5: 10.7x ←	3. Serie 5 Skott 	1: 10.2 ← 2: 9.9 ↑ 3: 9.7 ↗ 4: 9.5 ← 5: 10.6x →	Serie	50
Serie		50		Serie	47
Total		97		Total	144
	1: 10.4 ↖ 2: 10.3 → 3: 9.4 ↓ 4: 9.5 ↗ 5: 9.9 →	Prov 	1: 10.8x → 2: 10.0 ↓ 3: 9.9 ↙ 4: 10.6x ↙ 5: 9.2 ↓ 6: 10.1 ↘	Serie	47
Serie		47		Serie	58
Total		191		Total	191
	1: 9.8 ← 2: 10.9x ↑ 3: 10.4 ← 4: 9.7 ↑ 5: 10.2 ↖	6. Serie 5 Skott 	1: 10.2 ↙ 2: 10.2 → 3: 9.2 ↓ 4: 9.6 ↗ 5: 10.1 ←	Serie	48
Serie		48		Serie	48
Total		239		Total	287
	1: 10.6x ↑ 2: 9.1 → 3: 9.2 ↗ 4: 9.9 ↑ 5: 9.8 →				
Serie		46			
Total		333			

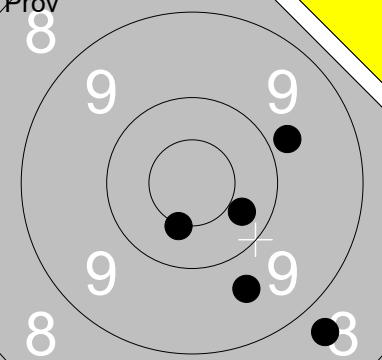
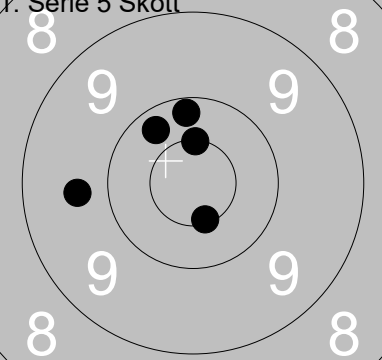
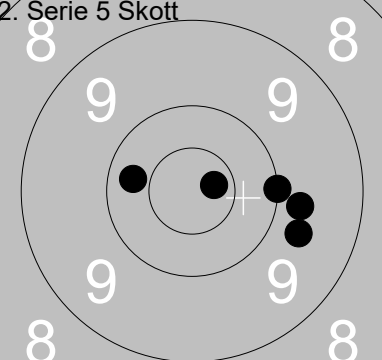
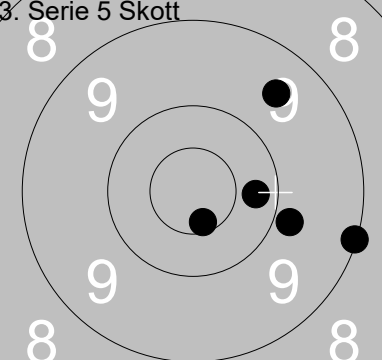
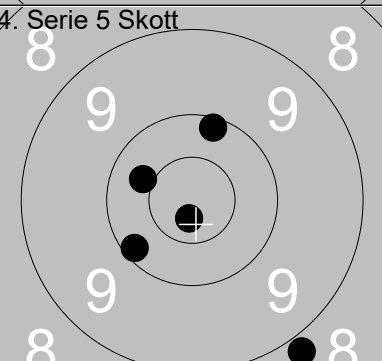
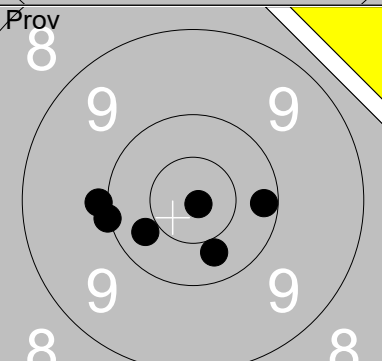
Skjutlag 3	Tavla 4	Hans Arnkvist	
Ramselefors	Gräsmark	C	Vä
07.07.2019	Tavelträffen 2019	Ramselefors SKF	
	1: 9.2 ↖ 2: 10.0 ↗ 3: 9.9 ← 4: 10.3 ↑ 5: 10.4x ←		1: 10.6x ↘ 2: 9.1 ↓ 3: 10.2 ↘ 4: 10.1 ↓ 5: 9.0 ↘
	Serie 48 Total 0		Serie 48 Total 48
	1: 10.4 → 2: 10.7x ↑ 3: 9.7 → 4: 10.7x ↓ 5: 10.4 ←		1: 8.7 ↑ 2: 9.7 ↗ 3: 10.0 ↑ 4: 10.6x ← 5: 10.2 ↓
	Serie 49 Total 97		Serie 47 Total 144
	1: 10.6x ← 2: 10.0 ↑ 3: 10.4x ← 4: 10.8x ← 5: 9.8 ↓		1: 10.2 ↘ 2: 9.5 ↓ 3: 10.4 ← 4: 9.7 ↘ 5: 8.4 ↓ 6: 9.3 →
	Serie 49 Total 193		Serie 55 Total 193
	1: 10.1 ↖ 2: 10.3 → 3: 9.4 ↓ 4: 9.8 ↓ 5: 10.4x ↓		1: 8.4 → 2: 9.5 ↑ 3: 8.9 ← 4: 3.9 → 5: 10.7x ↓
	Serie 48 Total 241		Serie 38 Total 279
	1: 9.7 → 2: 6.5 → 3: 9.1 ↗ 4: 10.7x → 5: 8.0 →		
	Serie 42 Total 321		

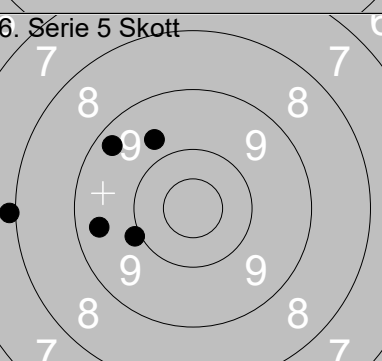
Skjutlag	Tavla	Joakim Arnkvist	
3	5		
Ramselefors	Gräsmark	C	Vä
07.07.2019	Tavelträffen 2019	Ramselefors SKF	
	1: 10.1 ↖ 2: 10.3 ← 3: 9.5 ↑ 4: 10.3 ↑ 5: 10.1 ←	1. Serie 5 Skott 	1: 9.4 ↑ 2: 9.8 ← 3: 10.8x ← 4: 10.2 ↘ 5: 9.2 ↖
Serie 49	Total 0	Serie 47	Total 47
2. Serie 5 Skott 	1: 10.7x ← 2: 10.1 ↑ 3: 8.9 ↑ 4: 9.7 ↗ 5: 10.4x ←	3. Serie 5 Skott 	1: 10.3 ↓ 2: 10.2 ↖ 3: 10.4x ↗ 4: 9.8 ↑ 5: 10.1 ↘
Serie 47	Total 94	Serie 49	Total 143
4. Serie 5 Skott 	1: 9.8 ↓ 2: 9.1 ↓ 3: 8.8 ← 4: 9.7 ↑ 5: 8.1 ↓	Prov 	1: 7.5 ↗ 2: 8.9 ↗ 3: 9.8 ↑ 4: 9.1 ↗ 5: 9.9 ← 6: 10.8x ↘
Serie 43	Total 186	Serie 52	Total 186
5. Serie 5 Skott 	1: 10.5x ↑ 2: 9.6 ← 3: 10.5x ↗ 4: 10.3 → 5: 9.4 ←	6. Serie 5 Skott 	1: 9.4 ↗ 2: 8.4 ↗ 3: 10.7x → 4: 9.6 ↑ 5: 10.5x →
Serie 48	Total 234	Serie 46	Total 280
7. Serie 5 Skott 	1: 9.7 ↖ 2: 7.2 ↑ 3: 6.7 → 4: 6.9 → 5: 9.9 ↗		
Serie 37	Total 317		

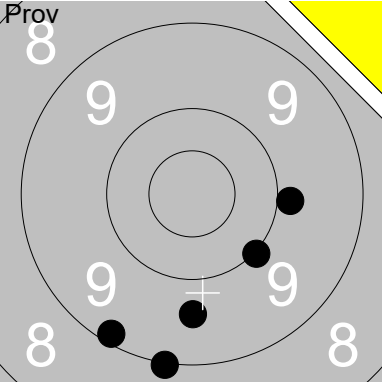
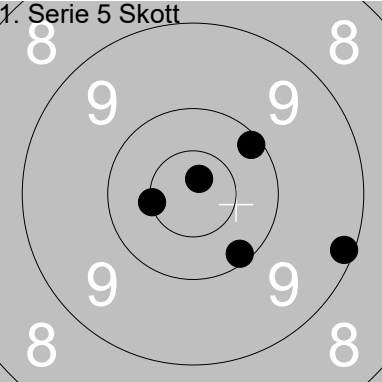
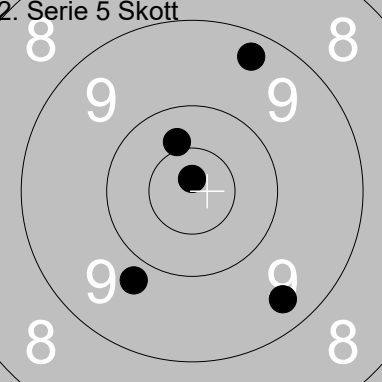
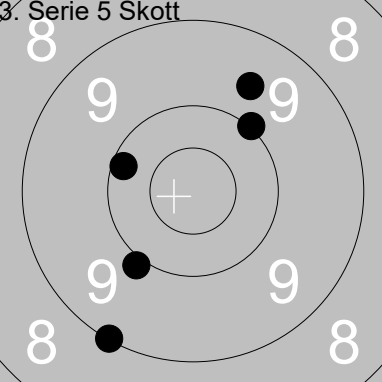
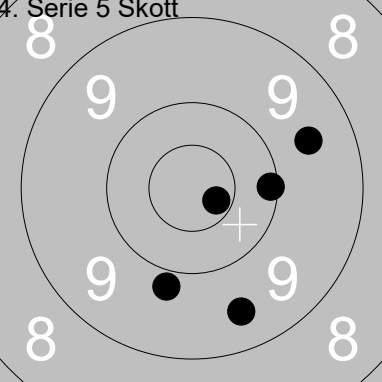
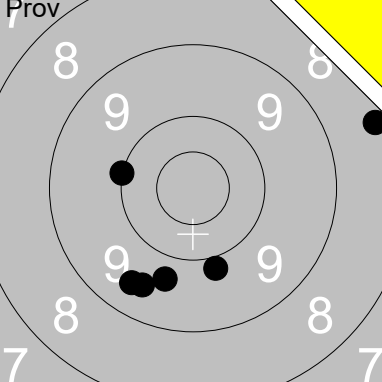
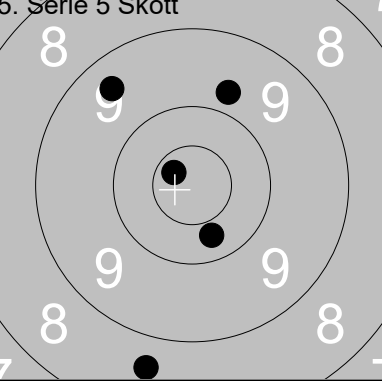
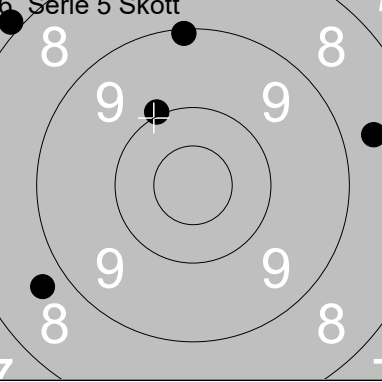
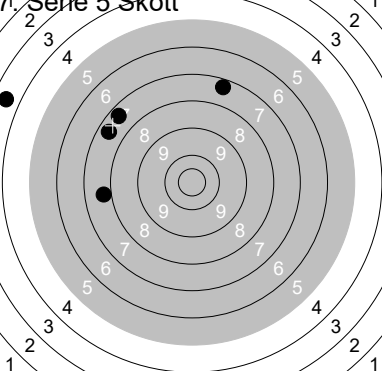

	<p>1: 10.3 →</p> <p>2: 10.5x ↓</p> <p>3: 8.7 ↓</p> <p>4: 9.8 →</p> <p>5: 9.6 ↓</p>	<p>1. Serie 5 Skott</p> 	<p>1: 10.5x ↓</p> <p>2: 9.7 ←</p> <p>3: 10.2 ↑</p> <p>4: 10.3 ↗</p> <p>5: 10.5x ↑</p>
Serie 46	Total 0	Serie 49	Total 49
<p>2. Serie 5 Skott</p> 	<p>1: 10.3 ←</p> <p>2: 9.8 →</p> <p>3: 9.7 ↓</p> <p>4: 10.0 →</p> <p>5: 10.7x →</p>	<p>3. Serie 5 Skott</p> 	<p>1: 10.6x ↓</p> <p>2: 9.5 ↗</p> <p>3: 9.1 →</p> <p>4: 9.8 →</p> <p>5: 10.3 →</p>
Serie 48	Total 97	Serie 47	Total 144
<p>4. Serie 5 Skott</p> 	<p>1: 10.1 ←</p> <p>2: 10.7x ↓</p> <p>3: 8.8 ↓</p> <p>4: 10.4 ←</p> <p>5: 10.1 ↑</p>	<p>Prov</p> 	<p>1: 10.3 ↓</p> <p>2: 10.3 ←</p> <p>3: 9.9 ←</p> <p>4: 10.9x ↓</p> <p>5: 10.2 →</p> <p>6: 10.0 ←</p>
Serie 48	Total 192	Serie 59	Total 192
<p>5. Serie 5 Skott</p> 	<p>1: 9.7 ↗</p> <p>2: 10.3 ↑</p> <p>3: 10.4x ↑</p> <p>4: 10.6x ↗</p> <p>5: 9.6 ←</p>	<p>6. Serie 5 Skott</p> 	<p>1: 7.9 ←</p> <p>2: 9.9 ←</p> <p>3: 9.7 ↗</p> <p>4: 9.3 ↗</p> <p>5: 9.4 ←</p>
Serie 48	Total 240	Serie 43	Total 283
<p>7. Serie 5 Skott</p> 	<p>1: 9.3 ↗</p> <p>2: 9.0 ↑</p> <p>3: 9.0 ↑</p> <p>4: 9.9 →</p> <p>5: 10.4x ↗</p>		
Serie 46	Total 329		

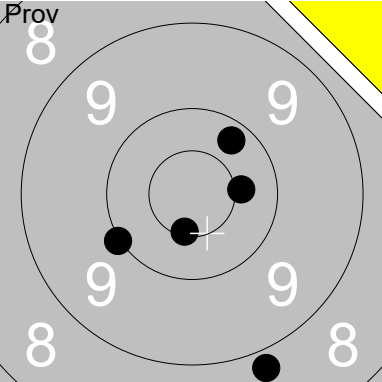
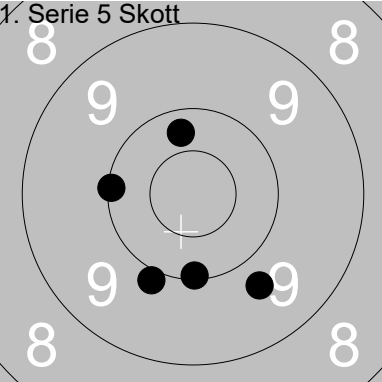
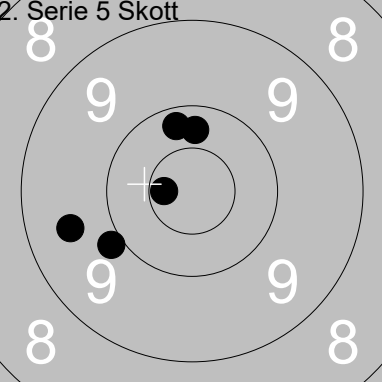
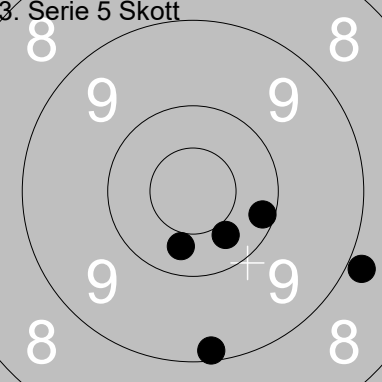
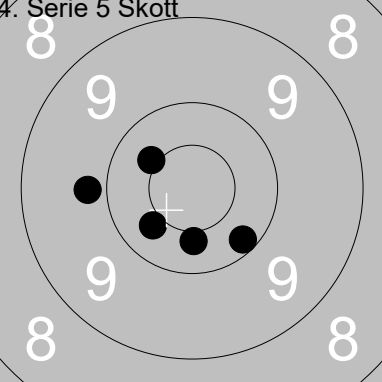
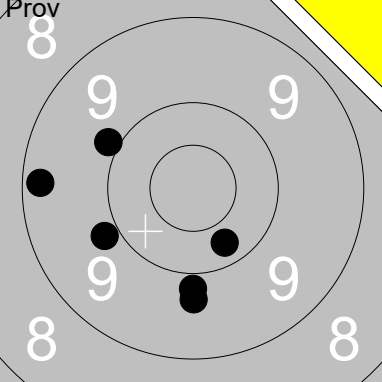
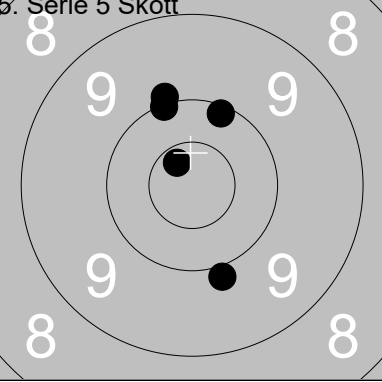
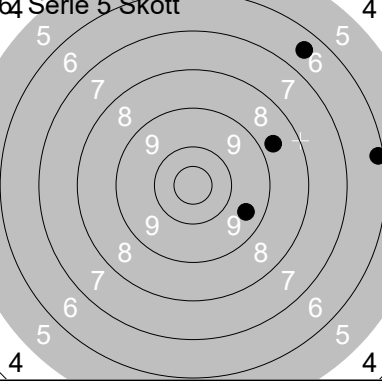
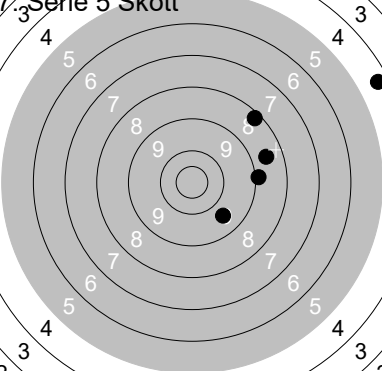

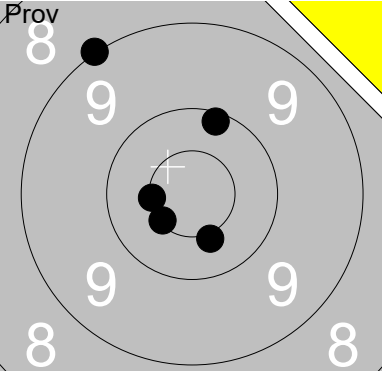
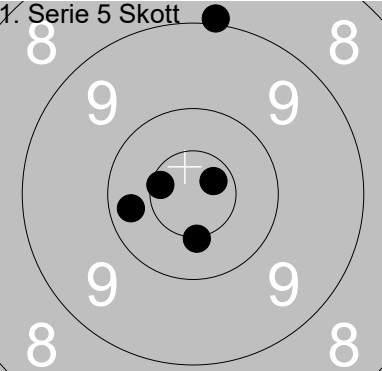
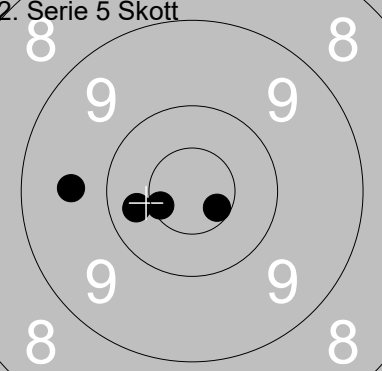
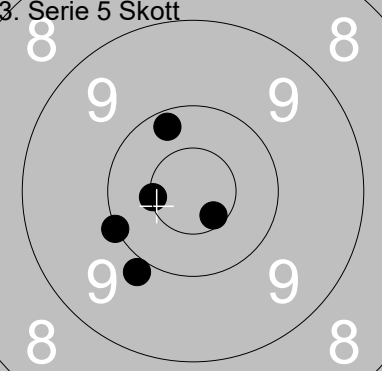
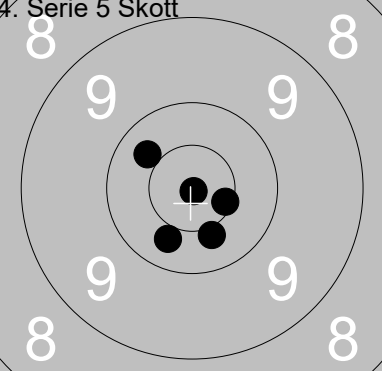
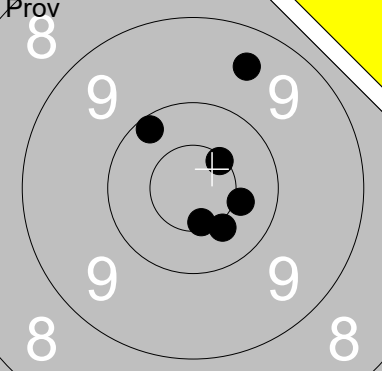
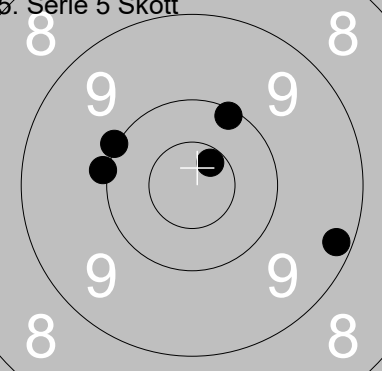
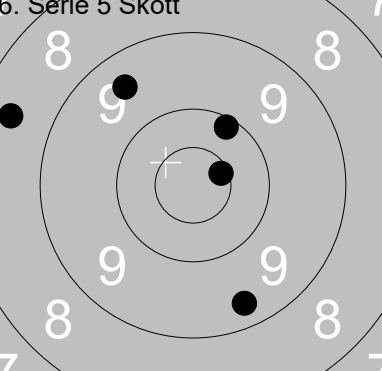
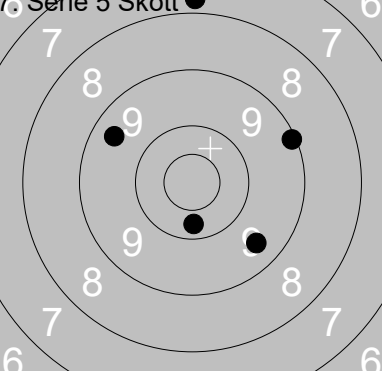

Skjutlag	Tavla	Mikael Nilsson	
3	8	Bromma-Solna	St
Ramselefors		B	
07.07.2019	Tavelträffen 2019	Ramselefors SKF	
	1: 9.0 ↓ 2: 9.6 ↓↓ 3: 10.0 ↓↓ 4: 9.9 → 5: 9.1 ↓	1. Serie 5 Skott 	1: 10.8x ↑ 2: 9.1 → 3: 10.1 ↗ 4: 10.5x ← 5: 10.1 ↓
Serie 46	Total 0	Serie 49	Total 49
2. Serie 5 Skott 	1: 10.4 ↑ 2: 9.3 ↗ 3: 10.8x ↑ 4: 9.4 ↓ 5: 9.8 ↓	3. Serie 5 Skott 	1: 10.0 ↗ 2: 9.6 ↗ 3: 9.0 ↓ 4: 10.1 ← 5: 9.9 ↓
Serie 47	Total 96	Serie 47	Total 143
4. Serie 5 Skott 	1: 9.6 → 2: 9.8 ↓ 3: 9.5 ↓ 4: 10.1 → 5: 10.7x →	Prov 	1: 9.9 ↓ 2: 9.5 ↓ 3: 9.7 ↓ 4: 9.5 ↓ 5: 8.3 → 6: 10.0 ←
Serie 47	Total 190	Serie 54	Total 190
5. Serie 5 Skott 	1: 10.3 ↓ 2: 10.7x ↗ 3: 9.8 ↗ 4: 9.4 ↗ 5: 8.6 ↓	6. Serie 5 Skott 	1: 9.1 ↑ 2: 8.6 → 3: 10.0 ↗ 4: 8.7 ← 5: 7.9 ↖
Serie 46	Total 236	Serie 42	Total 278
7. Serie 5 Skott 	1: 7.7 ← 2: 7.4 ↗ 3: 3.5 ↗ 4: 7.3 ↗ 5: 7.4 ↗		
Serie 31	Total 309		

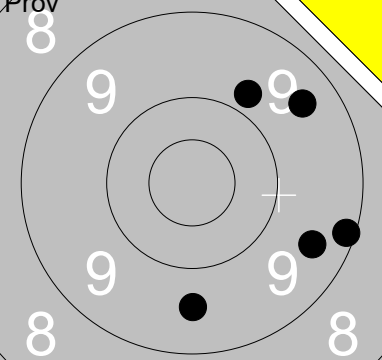
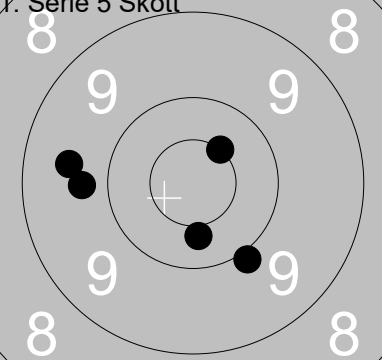
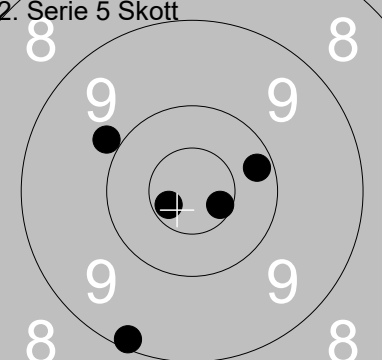
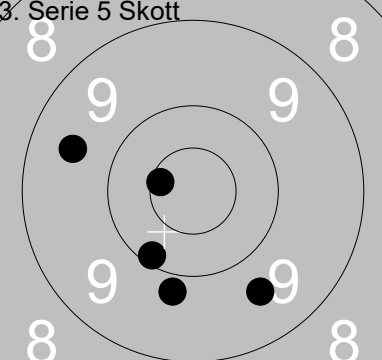
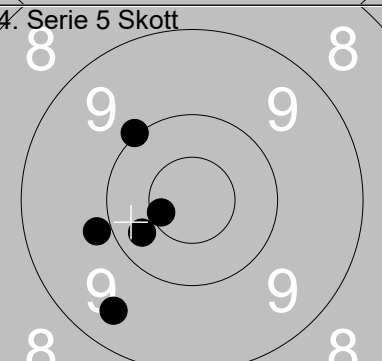
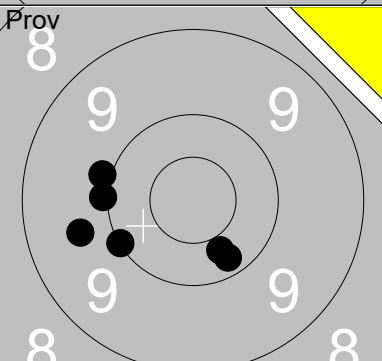
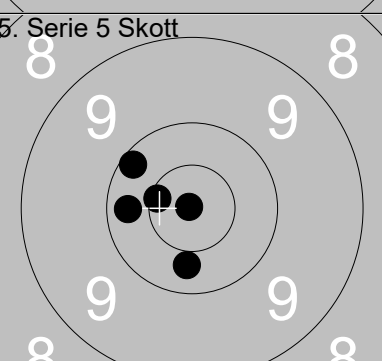
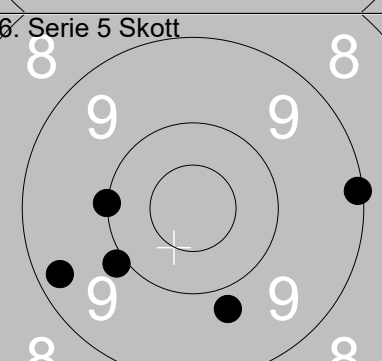

Skjutlag	Tavla	Jan Wallerström		
3	9	Ramselefors	Ununge	B St
07.07.2019	Tavelträffen 2019	Ramselefors SKF		
	1: 8.8 2: 10.5x 3: 10.0 4: 10.2 5: 10.4x	1. Serie 5 Skott 	1: 9.7 2: 10.3 3: 9.9 4: 10.1 5: 10.1	
Serie 48	Total 0	Serie 48	Total 48	
2. Serie 5 Skott 	1: 9.5 2: 10.6x 3: 10.3 4: 9.9 5: 10.2	3. Serie 5 Skott 	1: 9.1 2: 8.9 3: 10.2 4: 10.4 5: 10.3	
Serie 48	Total 96	Serie 47	Total 143	
4. Serie 5 Skott 	1: 10.4 2: 10.4x 3: 10.2 4: 9.8 5: 10.4	Prov 	1: 9.7 2: 9.9 3: 9.9 4: 10.3 5: 9.9 6: 9.2	
Serie 49	Total 192	Serie 55	Total 192	
5. Serie 5 Skott 	1: 9.9 2: 10.7x 3: 9.9 4: 10.1 5: 10.0	6. Serie 5 Skott 	1: 0.0 2: 6.2 3: 8.7 4: 9.5 5: 6.5	
Serie 48	Total 240	Serie 29	Total 269	
7. Serie 5 Skott 	1: 9.6 2: 8.2 3: 8.6 4: 8.9 5: 4.4			
Serie 37	Total 306			

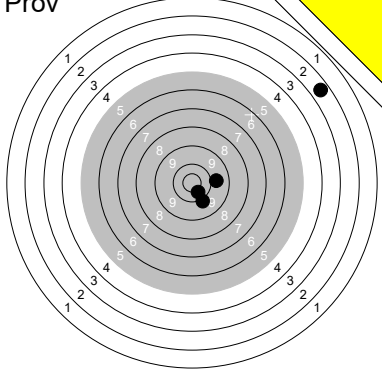
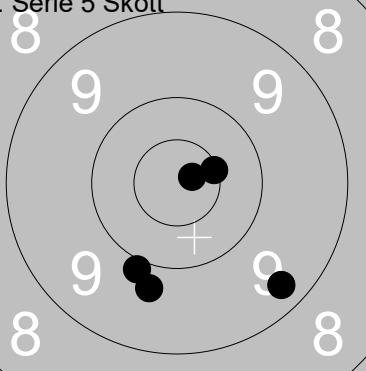
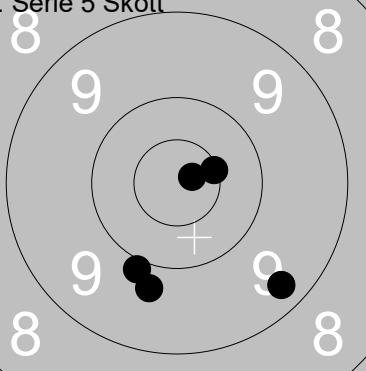
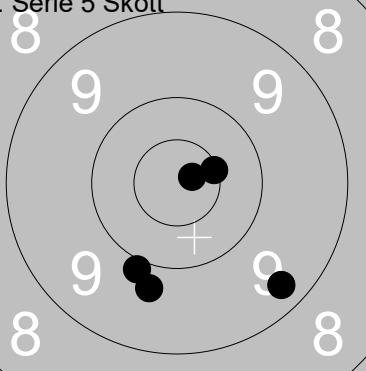
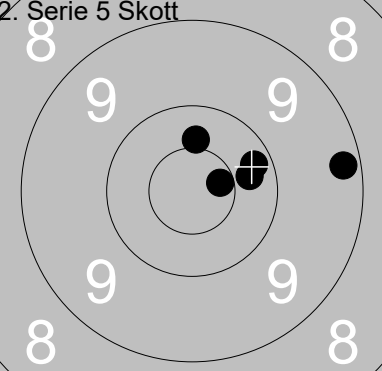
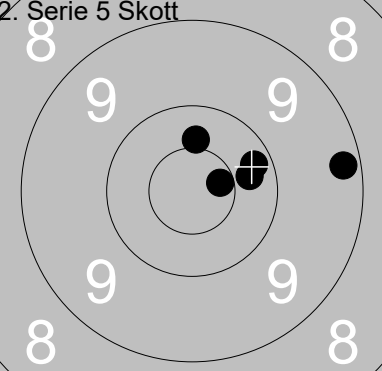
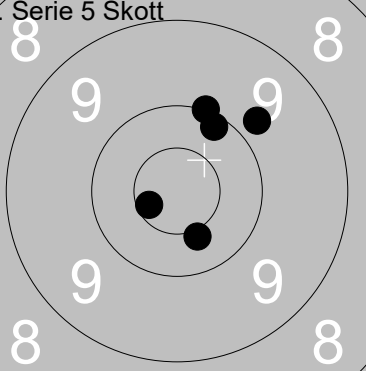
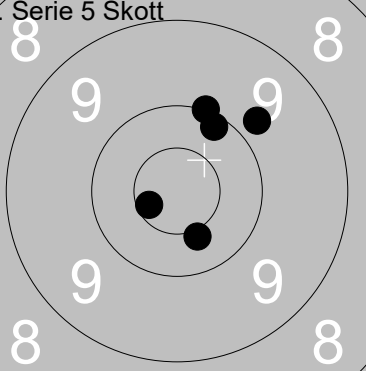
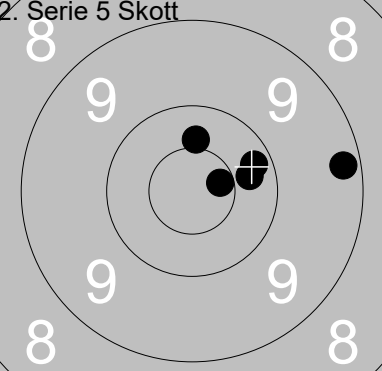
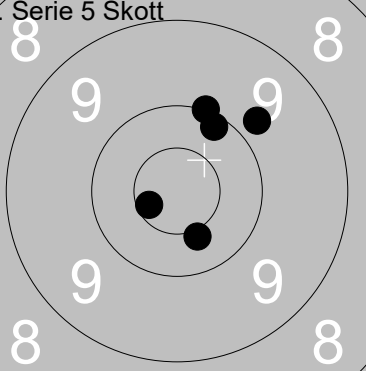
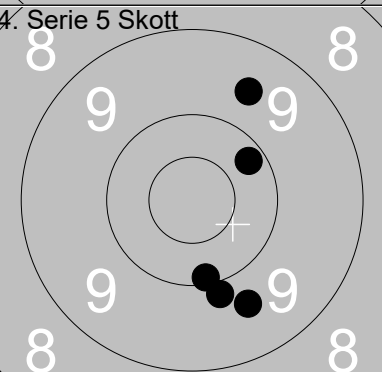
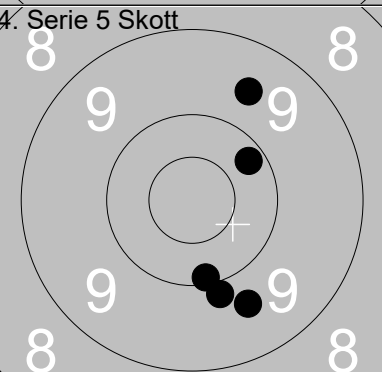
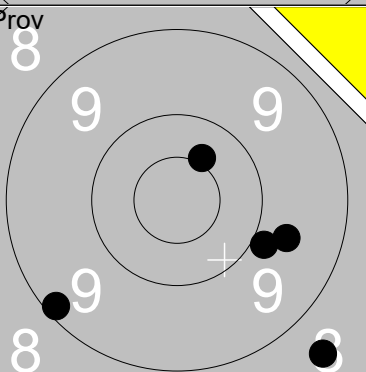
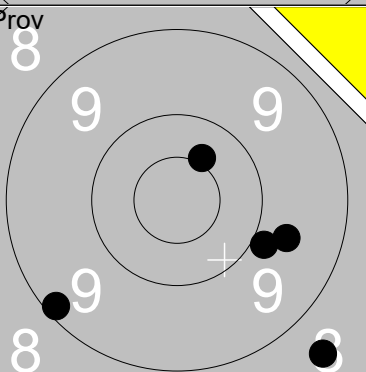
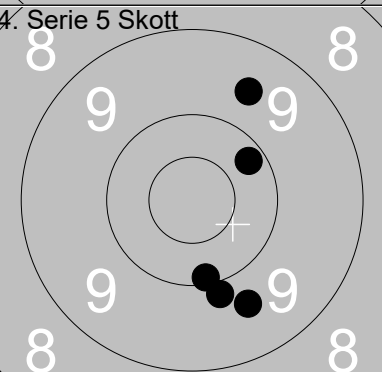
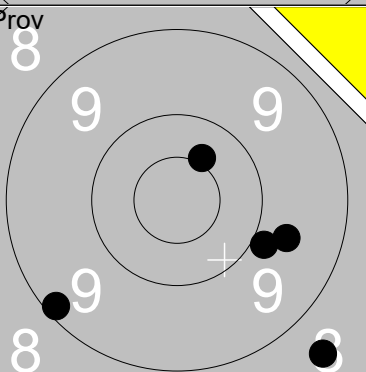
Skjutlag	Tavla	Kevin Arnmark	
3	10	Ramselefors	Västerås Friv Skarp
07.07.2019	Tavelträffen 2019	Ramselefors SKF	
	1: 9.3 ↙ 2: 10.1 ← 3: 9.9 ↗ 4: 10.0 → 5: 10.7x ←	1. Serie 5 Skott 	1: 10.1 ↑ 2: 9.5 ↘ 3: 9.5 ↗ 4: 10.2 ↓ 5: 9.6 ↖
	Serie 48		Serie 47
	Total 0		Total 47
2. Serie 5 Skott 	1: 9.6 → 2: 10.3 ← 3: 10.3 ↘ 4: 9.5 → 5: 10.2 ↗	3. Serie 5 Skott 	1: 8.1 ↖ 2: 9.2 ← 3: 8.9 ↗ 4: 9.4 ↗ 5: 9.3 ↗
	Serie 48		Serie 43
	Total 95		Total 138
4. Serie 5 Skott 	1: 10.3 ↓ 2: 9.7 ↓ 3: 10.4x ↙ 4: 9.4 ↗ 5: 10.0 →	4. Serie 5 Skott 	1: 8.4 → 2: 9.6 → 3: 10.3 ↓ 4: 10.7x ↙ 5: 8.9 ↗ 6: 10.6x ↙
	Serie 48		Serie 55
	Total 186		Total 186
5. Serie 5 Skott 	1: 10.6x ↗ 2: 10.4 → 3: 10.5x ↘ 4: 10.1 ↗ 5: 10.1 ↓	5. Serie 5 Skott 	1: 7.7 ← 2: 9.2 ↖ 3: 9.4 ↖ 4: 10.4x ← 5: 8.1 ↗
	Serie 50		Serie 43
	Total 236		Total 279
7. Serie 5 Skott 	1: 10.2 ↗ 2: 8.3 ← 3: 10.1 ↘ 4: 7.8 → 5: 7.2 →		
	Serie 42		
	Total 321		

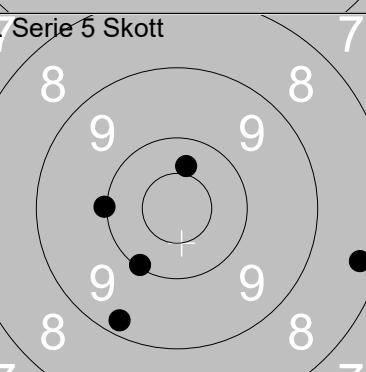
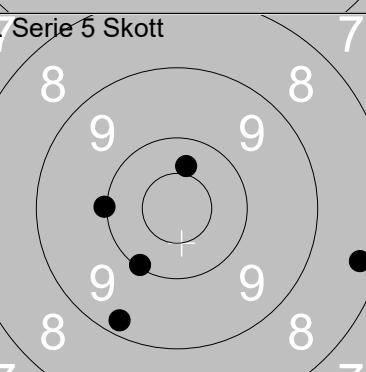
Skjutlag	Tavla	Lars Möllsten	
3	11		
Ramselefors	Umeå	B	Vb
07.07.2019	Tavelträffen 2019	Ramselefors SKF	
	1: 10.4x ↓ 2: 10.1 ↑ 3: 10.5x ← 4: 9.0 ↗ 5: 10.5x ↘	1. Serie 5 Skott 	1: 9.0 ↑ 2: 10.3 ← 3: 10.7x ↗ 4: 10.6x ← 5: 10.5x ↓
Serie 49	Total 0	Serie 49	Total 49
2. Serie 5 Skott 	1: 9.6 ← 2: 10.6x ← 3: 10.3 ← 4: 10.3 ← 5: 10.6x ↘	3. Serie 5 Skott 	1: 10.2 ↑ 2: 10.0 ← 3: 9.9 ↓ 4: 10.5x ← 5: 10.6x ↘
Serie 49	Total 98	Serie 49	Total 147
4. Serie 5 Skott 	1: 10.6x → 2: 10.3 ↓ 3: 10.4 ↓ 4: 10.3 ↗ 5: 10.9x ↘	Prov 	1: 9.5 ↑ 2: 10.5x ↗ 3: 10.6x ↓ 4: 10.4x ↓ 5: 10.4 → 6: 10.2 ↗
Serie 50	Total 197	Serie 59	Total 197
5. Serie 5 Skott 	1: 10.0 ← 2: 10.1 ↑ 3: 10.6x ↗ 4: 10.0 ← 5: 9.2 →	6. Serie 5 Skott 	1: 8.5 ← 2: 9.5 ↗ 3: 10.1 ↑ 4: 9.3 ↓ 5: 10.6x →
Serie 49	Total 246	Serie 46	Total 292
7. Serie 5 Skott 	1: 10.3 ↓ 2: 9.4 ↗ 3: 7.8 ↑ 4: 9.1 → 5: 9.5 ↘		
Serie 44	Total 336		

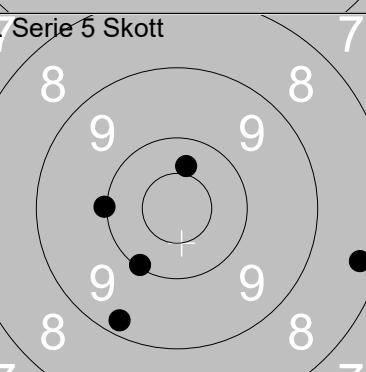
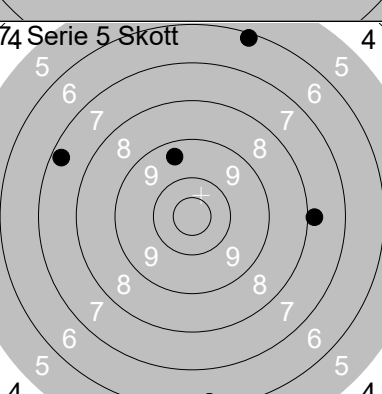
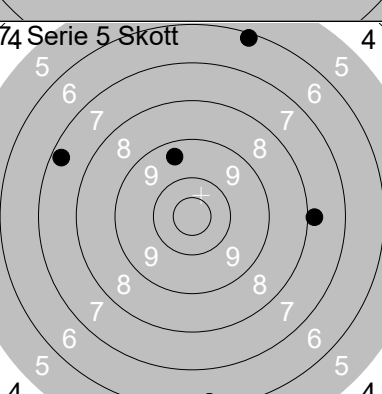
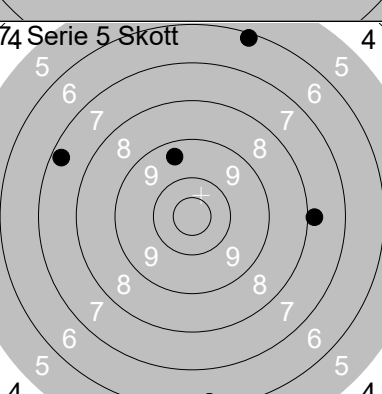

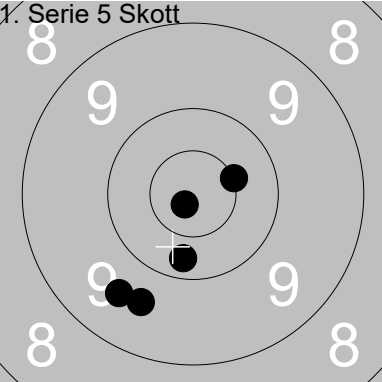
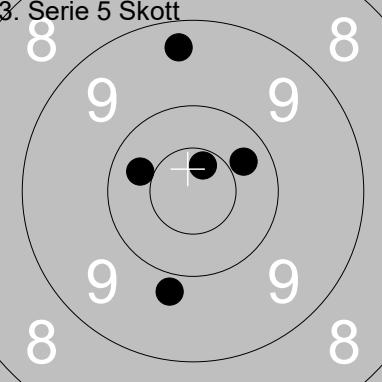
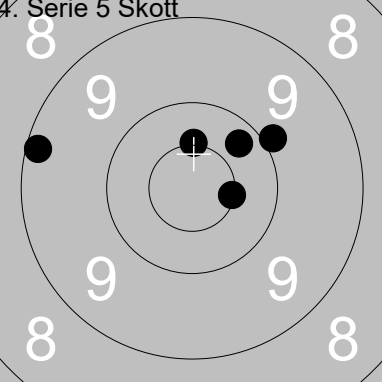
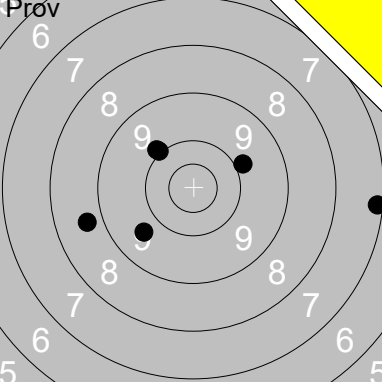
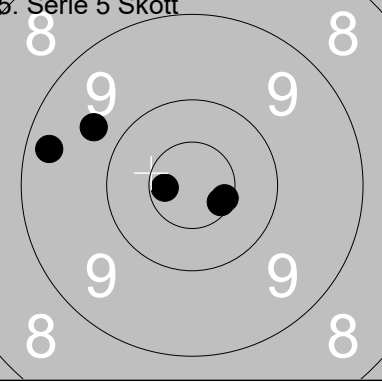
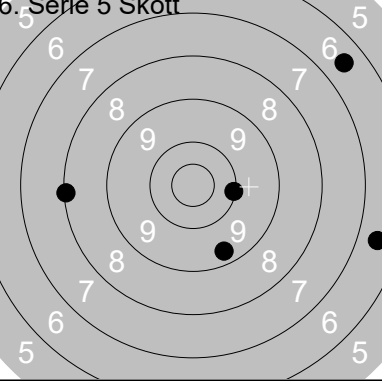
 <p>Prov</p>	<p>1: 9.4 ↗ 2: 9.8 ↗ 3: 9.1 → 4: 9.6 ↓ 5: 9.5 →</p>	<p>1. Serie 5 Skott</p> 	<p>1: 9.6 ← 2: 10.4 ↓ 3: 10.5x ↗ 4: 9.9 ↓ 5: 9.7 ←</p>
	<p>Serie 45 Total 0</p>		<p>Serie 47 Total 47</p>
<p>2. Serie 5 Skott</p> 	<p>1: 10.7x ← 2: 9.9 ← 3: 10.2 → 4: 10.6x → 5: 9.1 ↓</p>	<p>3. Serie 5 Skott</p> 	<p>1: 9.6 ↓ 2: 9.5 ← 3: 10.6x ← 4: 10.1 ↓ 5: 9.8 ↓</p>
	<p>Serie 48 Total 95</p>		<p>Serie 47 Total 142</p>
<p>4. Serie 5 Skott</p> 	<p>1: 10.6x ← 2: 10.3 ← 3: 9.9 ← 4: 10.0 ↗ 5: 9.4 ↓</p>	<p>Prov</p> 	<p>1: 10.3 ↓ 2: 10.0 ← 3: 9.7 ← 4: 9.9 ← 5: 10.0 ← 6: 10.2 ↓</p>
	<p>Serie 48 Total 190</p>		<p>Serie 58 Total 190</p>
<p>5. Serie 5 Skott</p> 	<p>1: 10.9x ← 2: 10.6x ← 3: 10.2 ↗ 4: 10.3 ↓ 5: 10.3 ←</p>	<p>6. Serie 5 Skott</p> 	<p>1: 9.9 ← 2: 10.0 ← 3: 9.3 ← 4: 9.8 ↓ 5: 9.1 →</p>
	<p>Serie 50 Total 240</p>		<p>Serie 46 Total 286</p>
<p>7. Serie 5 Skott</p> 	<p>1: 8.0 ↓ 2: 6.4 → 3: 8.6 ↓ 4: 8.4 → 5: 8.9 ↗</p>		
	<p>Serie 38 Total 324</p>		

	<table border="1" style="width:100%; border-collapse: collapse;"> <tr><td>1:</td><td>0.0</td><td>↑</td></tr> <tr><td>2:</td><td>2.5</td><td>↗</td></tr> <tr><td>3:</td><td>9.9</td><td>↓</td></tr> <tr><td>4:</td><td>10.4</td><td>↓</td></tr> <tr><td>5:</td><td>9.7</td><td>→</td></tr> <tr><td colspan="2">Serie</td><td>30</td></tr> <tr><td colspan="2">Total</td><td>0</td></tr> </table>	1:	0.0	↑	2:	2.5	↗	3:	9.9	↓	4:	10.4	↓	5:	9.7	→	Serie		30	Total		0	<table border="1" style="width:100%; border-collapse: collapse;"> <tr><td colspan="2">1. Serie 5 Skott</td></tr> <tr><td colspan="2"></td></tr> <tr><td>1:</td><td>9.3</td><td>↓</td></tr> <tr><td>2:</td><td>9.9</td><td>↓</td></tr> <tr><td>3:</td><td>10.5x</td><td>→</td></tr> <tr><td>4:</td><td>9.8</td><td>↓</td></tr> <tr><td>5:</td><td>10.8x</td><td>→</td></tr> <tr><td colspan="2">Serie</td><td>47</td></tr> <tr><td colspan="2">Total</td><td>47</td></tr> </table>	1. Serie 5 Skott				1:	9.3	↓	2:	9.9	↓	3:	10.5x	→	4:	9.8	↓	5:	10.8x	→	Serie		47	Total		47	<table border="1" style="width:100%; border-collapse: collapse;"> <tr><td>1:</td><td>9.3</td><td>↓</td></tr> <tr><td>2:</td><td>9.9</td><td>↓</td></tr> <tr><td>3:</td><td>10.5x</td><td>→</td></tr> <tr><td>4:</td><td>9.8</td><td>↓</td></tr> <tr><td>5:</td><td>10.8x</td><td>→</td></tr> <tr><td colspan="2">Serie</td><td>47</td></tr> <tr><td colspan="2">Total</td><td>47</td></tr> </table>	1:	9.3	↓	2:	9.9	↓	3:	10.5x	→	4:	9.8	↓	5:	10.8x	→	Serie		47	Total		47																									
1:	0.0	↑																																																																																													
2:	2.5	↗																																																																																													
3:	9.9	↓																																																																																													
4:	10.4	↓																																																																																													
5:	9.7	→																																																																																													
Serie		30																																																																																													
Total		0																																																																																													
1. Serie 5 Skott																																																																																															
																																																																																															
1:	9.3	↓																																																																																													
2:	9.9	↓																																																																																													
3:	10.5x	→																																																																																													
4:	9.8	↓																																																																																													
5:	10.8x	→																																																																																													
Serie		47																																																																																													
Total		47																																																																																													
1:	9.3	↓																																																																																													
2:	9.9	↓																																																																																													
3:	10.5x	→																																																																																													
4:	9.8	↓																																																																																													
5:	10.8x	→																																																																																													
Serie		47																																																																																													
Total		47																																																																																													
<table border="1" style="width:100%; border-collapse: collapse;"> <tr><td colspan="2">2. Serie 5 Skott</td></tr> <tr><td colspan="2"></td></tr> <tr><td>1:</td><td>10.4</td><td>↑</td></tr> <tr><td>2:</td><td>10.6x</td><td>→</td></tr> <tr><td>3:</td><td>9.2</td><td>→</td></tr> <tr><td>4:</td><td>10.2</td><td>→</td></tr> <tr><td>5:</td><td>10.3</td><td>→</td></tr> <tr><td colspan="2">Serie</td><td>49</td></tr> <tr><td colspan="2">Total</td><td>96</td></tr> </table>	2. Serie 5 Skott				1:	10.4	↑	2:	10.6x	→	3:	9.2	→	4:	10.2	→	5:	10.3	→	Serie		49	Total		96	<table border="1" style="width:100%; border-collapse: collapse;"> <tr><td>1:</td><td>10.4</td><td>↑</td></tr> <tr><td>2:</td><td>10.6x</td><td>→</td></tr> <tr><td>3:</td><td>9.2</td><td>→</td></tr> <tr><td>4:</td><td>10.2</td><td>→</td></tr> <tr><td>5:</td><td>10.3</td><td>→</td></tr> <tr><td colspan="2">Serie</td><td>49</td></tr> <tr><td colspan="2">Total</td><td>96</td></tr> </table>	1:	10.4	↑	2:	10.6x	→	3:	9.2	→	4:	10.2	→	5:	10.3	→	Serie		49	Total		96	<table border="1" style="width:100%; border-collapse: collapse;"> <tr><td colspan="2">3. Serie 5 Skott</td></tr> <tr><td colspan="2"></td></tr> <tr><td>1:</td><td>9.8</td><td>↗</td></tr> <tr><td>2:</td><td>10.0</td><td>↑</td></tr> <tr><td>3:</td><td>10.6x</td><td>←</td></tr> <tr><td>4:</td><td>10.4</td><td>↓</td></tr> <tr><td>5:</td><td>10.1</td><td>↑</td></tr> <tr><td colspan="2">Serie</td><td>49</td></tr> <tr><td colspan="2">Total</td><td>145</td></tr> </table>	3. Serie 5 Skott				1:	9.8	↗	2:	10.0	↑	3:	10.6x	←	4:	10.4	↓	5:	10.1	↑	Serie		49	Total		145	<table border="1" style="width:100%; border-collapse: collapse;"> <tr><td>1:</td><td>9.8</td><td>↗</td></tr> <tr><td>2:</td><td>10.0</td><td>↑</td></tr> <tr><td>3:</td><td>10.6x</td><td>←</td></tr> <tr><td>4:</td><td>10.4</td><td>↓</td></tr> <tr><td>5:</td><td>10.1</td><td>↑</td></tr> <tr><td colspan="2">Serie</td><td>49</td></tr> <tr><td colspan="2">Total</td><td>145</td></tr> </table>	1:	9.8	↗	2:	10.0	↑	3:	10.6x	←	4:	10.4	↓	5:	10.1	↑	Serie		49	Total		145
2. Serie 5 Skott																																																																																															
																																																																																															
1:	10.4	↑																																																																																													
2:	10.6x	→																																																																																													
3:	9.2	→																																																																																													
4:	10.2	→																																																																																													
5:	10.3	→																																																																																													
Serie		49																																																																																													
Total		96																																																																																													
1:	10.4	↑																																																																																													
2:	10.6x	→																																																																																													
3:	9.2	→																																																																																													
4:	10.2	→																																																																																													
5:	10.3	→																																																																																													
Serie		49																																																																																													
Total		96																																																																																													
3. Serie 5 Skott																																																																																															
																																																																																															
1:	9.8	↗																																																																																													
2:	10.0	↑																																																																																													
3:	10.6x	←																																																																																													
4:	10.4	↓																																																																																													
5:	10.1	↑																																																																																													
Serie		49																																																																																													
Total		145																																																																																													
1:	9.8	↗																																																																																													
2:	10.0	↑																																																																																													
3:	10.6x	←																																																																																													
4:	10.4	↓																																																																																													
5:	10.1	↑																																																																																													
Serie		49																																																																																													
Total		145																																																																																													
<table border="1" style="width:100%; border-collapse: collapse;"> <tr><td colspan="2">4. Serie 5 Skott</td></tr> <tr><td colspan="2"></td></tr> <tr><td>1:</td><td>9.9</td><td>↓</td></tr> <tr><td>2:</td><td>10.1</td><td>↓</td></tr> <tr><td>3:</td><td>10.2</td><td>↗</td></tr> <tr><td>4:</td><td>9.7</td><td>↓</td></tr> <tr><td>5:</td><td>9.6</td><td>↑</td></tr> <tr><td colspan="2">Serie</td><td>47</td></tr> <tr><td colspan="2">Total</td><td>192</td></tr> </table>	4. Serie 5 Skott				1:	9.9	↓	2:	10.1	↓	3:	10.2	↗	4:	9.7	↓	5:	9.6	↑	Serie		47	Total		192	<table border="1" style="width:100%; border-collapse: collapse;"> <tr><td>1:</td><td>9.9</td><td>↓</td></tr> <tr><td>2:</td><td>10.1</td><td>↓</td></tr> <tr><td>3:</td><td>10.2</td><td>↗</td></tr> <tr><td>4:</td><td>9.7</td><td>↓</td></tr> <tr><td>5:</td><td>9.6</td><td>↑</td></tr> <tr><td colspan="2">Serie</td><td>47</td></tr> <tr><td colspan="2">Total</td><td>192</td></tr> </table>	1:	9.9	↓	2:	10.1	↓	3:	10.2	↗	4:	9.7	↓	5:	9.6	↑	Serie		47	Total		192	<table border="1" style="width:100%; border-collapse: collapse;"> <tr><td colspan="2">Prov</td></tr> <tr><td colspan="2"></td></tr> <tr><td>1:</td><td>10.4x</td><td>↑</td></tr> <tr><td>2:</td><td>9.7</td><td>→</td></tr> <tr><td>3:</td><td>9.9</td><td>→</td></tr> <tr><td>4:</td><td>9.2</td><td>↙</td></tr> <tr><td>5:</td><td>8.6</td><td>↓</td></tr> <tr><td colspan="2">Serie</td><td>45</td></tr> <tr><td colspan="2">Total</td><td>192</td></tr> </table>	Prov				1:	10.4x	↑	2:	9.7	→	3:	9.9	→	4:	9.2	↙	5:	8.6	↓	Serie		45	Total		192	<table border="1" style="width:100%; border-collapse: collapse;"> <tr><td>1:</td><td>10.4x</td><td>↑</td></tr> <tr><td>2:</td><td>9.7</td><td>→</td></tr> <tr><td>3:</td><td>9.9</td><td>→</td></tr> <tr><td>4:</td><td>9.2</td><td>↙</td></tr> <tr><td>5:</td><td>8.6</td><td>↓</td></tr> <tr><td colspan="2">Serie</td><td>45</td></tr> <tr><td colspan="2">Total</td><td>192</td></tr> </table>	1:	10.4x	↑	2:	9.7	→	3:	9.9	→	4:	9.2	↙	5:	8.6	↓	Serie		45	Total		192
4. Serie 5 Skott																																																																																															
																																																																																															
1:	9.9	↓																																																																																													
2:	10.1	↓																																																																																													
3:	10.2	↗																																																																																													
4:	9.7	↓																																																																																													
5:	9.6	↑																																																																																													
Serie		47																																																																																													
Total		192																																																																																													
1:	9.9	↓																																																																																													
2:	10.1	↓																																																																																													
3:	10.2	↗																																																																																													
4:	9.7	↓																																																																																													
5:	9.6	↑																																																																																													
Serie		47																																																																																													
Total		192																																																																																													
Prov																																																																																															
																																																																																															
1:	10.4x	↑																																																																																													
2:	9.7	→																																																																																													
3:	9.9	→																																																																																													
4:	9.2	↙																																																																																													
5:	8.6	↓																																																																																													
Serie		45																																																																																													
Total		192																																																																																													
1:	10.4x	↑																																																																																													
2:	9.7	→																																																																																													
3:	9.9	→																																																																																													
4:	9.2	↙																																																																																													
5:	8.6	↓																																																																																													
Serie		45																																																																																													
Total		192																																																																																													
<table border="1" style="width:100%; border-collapse: collapse;"> <tr><td colspan="2">5. Serie 5 Skott</td></tr> <tr><td colspan="2"></td></tr> <tr><td>1:</td><td>9.1</td><td>↑</td></tr> <tr><td>2:</td><td>9.3</td><td>↓</td></tr> <tr><td>3:</td><td>10.7x</td><td>↙</td></tr> <tr><td>4:</td><td>9.6</td><td>←</td></tr> <tr><td>5:</td><td>10.4x</td><td>←</td></tr> <tr><td colspan="2">Serie</td><td>47</td></tr> <tr><td colspan="2">Total</td><td>239</td></tr> </table>	5. Serie 5 Skott				1:	9.1	↑	2:	9.3	↓	3:	10.7x	↙	4:	9.6	←	5:	10.4x	←	Serie		47	Total		239	<table border="1" style="width:100%; border-collapse: collapse;"> <tr><td>1:</td><td>9.1</td><td>↑</td></tr> <tr><td>2:</td><td>9.3</td><td>↓</td></tr> <tr><td>3:</td><td>10.7x</td><td>↙</td></tr> <tr><td>4:</td><td>9.6</td><td>←</td></tr> <tr><td>5:</td><td>10.4x</td><td>←</td></tr> <tr><td colspan="2">Serie</td><td>47</td></tr> <tr><td colspan="2">Total</td><td>239</td></tr> </table>	1:	9.1	↑	2:	9.3	↓	3:	10.7x	↙	4:	9.6	←	5:	10.4x	←	Serie		47	Total		239	<table border="1" style="width:100%; border-collapse: collapse;"> <tr><td colspan="2">6. Serie 5 Skott</td></tr> <tr><td colspan="2"></td></tr> <tr><td>1:</td><td>9.2</td><td>↓</td></tr> <tr><td>2:</td><td>10.1</td><td>↓</td></tr> <tr><td>3:</td><td>10.4</td><td>↑</td></tr> <tr><td>4:</td><td>10.0</td><td>←</td></tr> <tr><td>5:</td><td>8.3</td><td>→</td></tr> <tr><td colspan="2">Serie</td><td>47</td></tr> <tr><td colspan="2">Total</td><td>286</td></tr> </table>	6. Serie 5 Skott				1:	9.2	↓	2:	10.1	↓	3:	10.4	↑	4:	10.0	←	5:	8.3	→	Serie		47	Total		286	<table border="1" style="width:100%; border-collapse: collapse;"> <tr><td>1:</td><td>9.2</td><td>↓</td></tr> <tr><td>2:</td><td>10.1</td><td>↓</td></tr> <tr><td>3:</td><td>10.4</td><td>↑</td></tr> <tr><td>4:</td><td>10.0</td><td>←</td></tr> <tr><td>5:</td><td>8.3</td><td>→</td></tr> <tr><td colspan="2">Serie</td><td>47</td></tr> <tr><td colspan="2">Total</td><td>286</td></tr> </table>	1:	9.2	↓	2:	10.1	↓	3:	10.4	↑	4:	10.0	←	5:	8.3	→	Serie		47	Total		286
5. Serie 5 Skott																																																																																															
																																																																																															
1:	9.1	↑																																																																																													
2:	9.3	↓																																																																																													
3:	10.7x	↙																																																																																													
4:	9.6	←																																																																																													
5:	10.4x	←																																																																																													
Serie		47																																																																																													
Total		239																																																																																													
1:	9.1	↑																																																																																													
2:	9.3	↓																																																																																													
3:	10.7x	↙																																																																																													
4:	9.6	←																																																																																													
5:	10.4x	←																																																																																													
Serie		47																																																																																													
Total		239																																																																																													
6. Serie 5 Skott																																																																																															
																																																																																															
1:	9.2	↓																																																																																													
2:	10.1	↓																																																																																													
3:	10.4	↑																																																																																													
4:	10.0	←																																																																																													
5:	8.3	→																																																																																													
Serie		47																																																																																													
Total		286																																																																																													
1:	9.2	↓																																																																																													
2:	10.1	↓																																																																																													
3:	10.4	↑																																																																																													
4:	10.0	←																																																																																													
5:	8.3	→																																																																																													
Serie		47																																																																																													
Total		286																																																																																													
<table border="1" style="width:100%; border-collapse: collapse;"> <tr><td colspan="2">7. Serie 5 Skott</td></tr> <tr><td colspan="2"></td></tr> <tr><td>1:</td><td>7.3</td><td>←</td></tr> <tr><td>2:</td><td>6.2</td><td>↓</td></tr> <tr><td>3:</td><td>6.2</td><td>↑</td></tr> <tr><td>4:</td><td>9.4</td><td>↑</td></tr> <tr><td>5:</td><td>7.9</td><td>→</td></tr> <tr><td colspan="2">Serie</td><td>35</td></tr> <tr><td colspan="2">Total</td><td>321</td></tr> </table>	7. Serie 5 Skott				1:	7.3	←	2:	6.2	↓	3:	6.2	↑	4:	9.4	↑	5:	7.9	→	Serie		35	Total		321	<table border="1" style="width:100%; border-collapse: collapse;"> <tr><td>1:</td><td>7.3</td><td>←</td></tr> <tr><td>2:</td><td>6.2</td><td>↓</td></tr> <tr><td>3:</td><td>6.2</td><td>↑</td></tr> <tr><td>4:</td><td>9.4</td><td>↑</td></tr> <tr><td>5:</td><td>7.9</td><td>→</td></tr> <tr><td colspan="2">Serie</td><td>35</td></tr> <tr><td colspan="2">Total</td><td>321</td></tr> </table>	1:	7.3	←	2:	6.2	↓	3:	6.2	↑	4:	9.4	↑	5:	7.9	→	Serie		35	Total		321																																																
7. Serie 5 Skott																																																																																															
																																																																																															
1:	7.3	←																																																																																													
2:	6.2	↓																																																																																													
3:	6.2	↑																																																																																													
4:	9.4	↑																																																																																													
5:	7.9	→																																																																																													
Serie		35																																																																																													
Total		321																																																																																													
1:	7.3	←																																																																																													
2:	6.2	↓																																																																																													
3:	6.2	↑																																																																																													
4:	9.4	↑																																																																																													
5:	7.9	→																																																																																													
Serie		35																																																																																													
Total		321																																																																																													

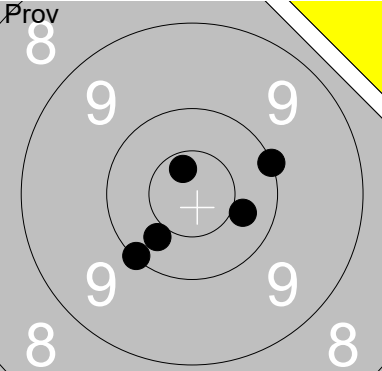
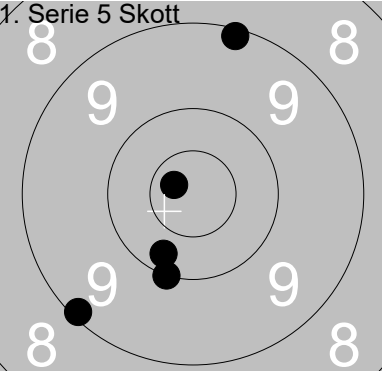
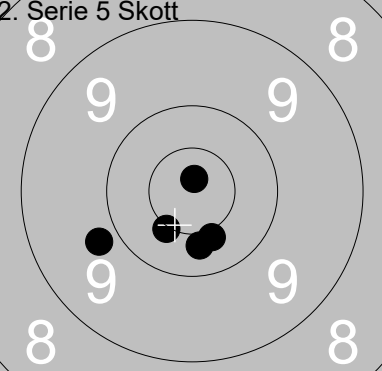
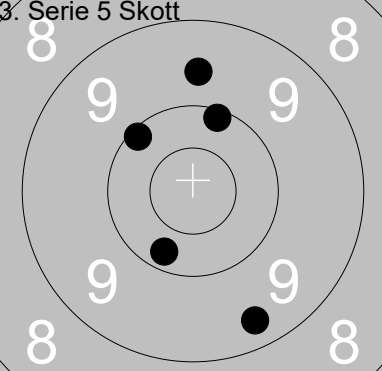
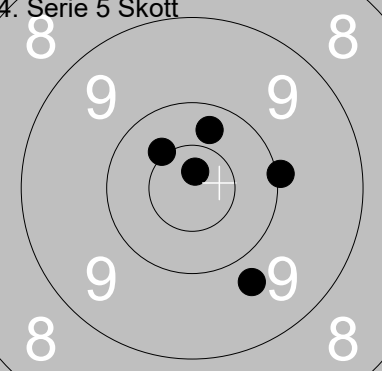
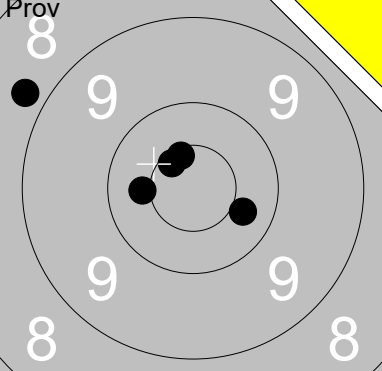
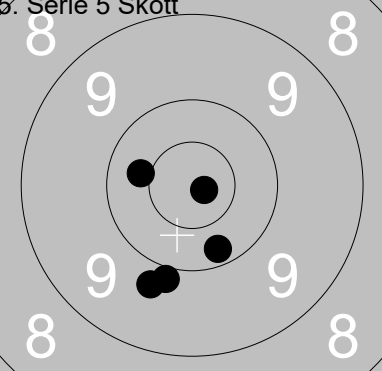
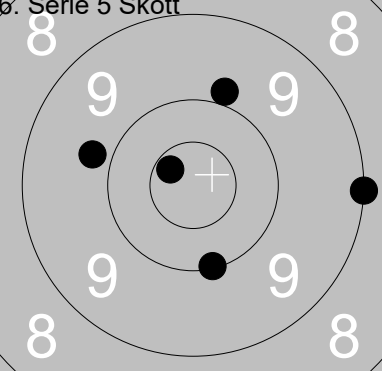
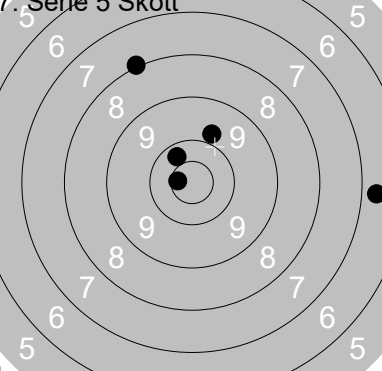
Skjutlag	Tavla	Roger Hjalström	
3	14		
Ramselefors	Ununge	B	St
07.07.2019	Tavelträffen 2019	Ramselefors SKF	
	1: 9.8 ↙ 2: 10.5x ↗ 3: 10.2 ↓ 4: 10.2 ↗ 5: 10.0 ↓	1. Serie 5 Skott 	1: 10.8x ↓ 2: 9.6 ↓ 3: 9.6 ↓ 4: 10.5x → 5: 10.2 ↓
Serie 49	Total 0	Serie 48	Total 48
2. Serie 5 Skott 	1: 10.3 ↙ 2: 10.3 ↗ 3: 9.7 ↗ 4: 9.5 ↑ 5: 10.7x ↙	3. Serie 5 Skott 	1: 10.3 → 2: 9.3 ↑ 3: 10.7x ↑ 4: 10.3 ↙ 5: 9.8 ↓
Serie 48	Total 96	Serie 48	Total 144
4. Serie 5 Skott 	1: 10.5x ↑ 2: 9.9 → 3: 9.2 ↙ 4: 10.5x → 5: 10.3 ↗	Prov 	1: 9.9 → 2: 8.7 ↙ 3: 10.0 ↗ 4: 9.9 ↗ 5: 9.6 ↓ 6: 7.1 →
Serie 48	Total 192	Serie 52	Total 192
5. Serie 5 Skott 	1: 10.6x → 2: 10.7x ↙ 3: 9.3 ↙ 4: 9.7 ↗ 5: 10.6x →	6. Serie 5 Skott 	1: 10.1 → 2: 6.5 ↗ 3: 9.3 ↓ 4: 8.1 ↙ 5: 6.5 →
Serie 48	Total 240	Serie 39	Total 279
7. Serie 5 Skott 	1: 8.2 ↑ 2: 10.2 ↓ 3: 9.5 ↗ 4: 8.7 ↙ 5: 10.3 ↘		
Serie 45	Total 324		

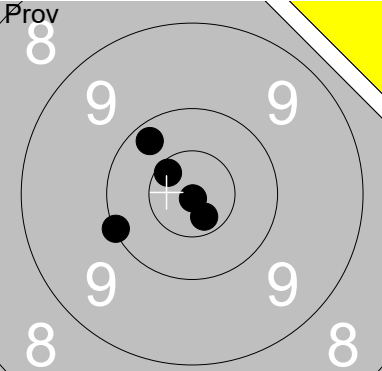
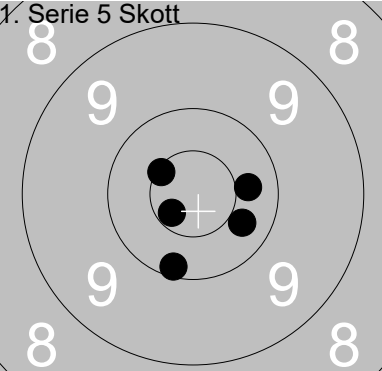
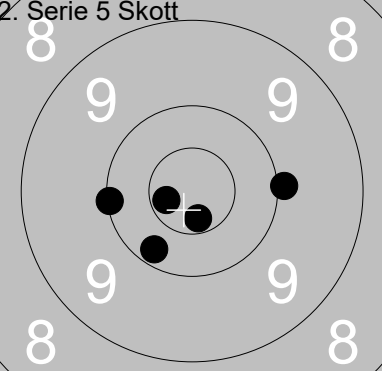
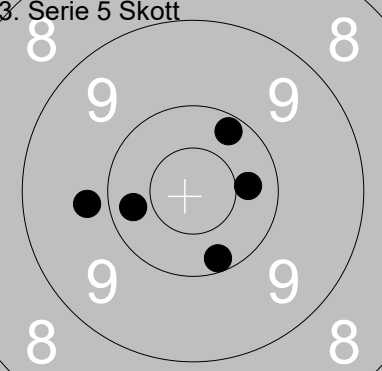
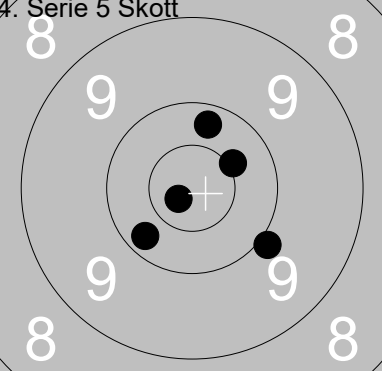
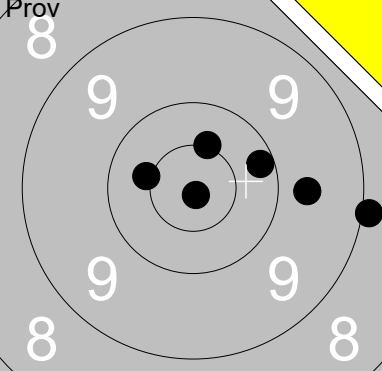
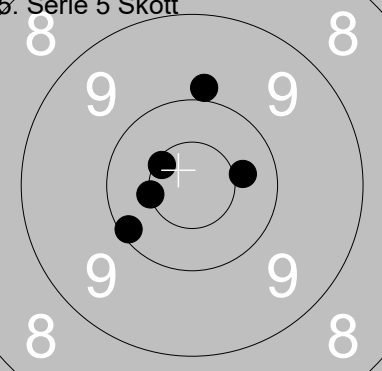
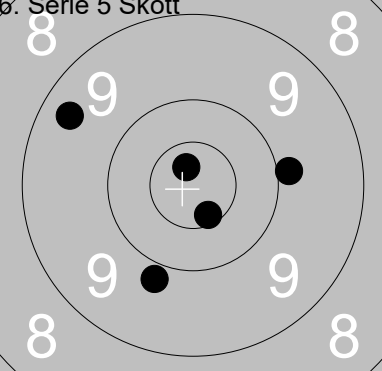
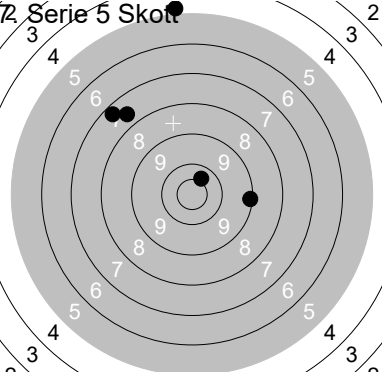
Skjutlag	Tavla	Martin Nilsson	
3	15	Ramselefors	Kvistbro
07.07.2019	Tavelträffen 2019	Ramselefors SKF	
	1: 10.0 → 2: 10.4 ↓ 3: 10.4 → 4: 10.7x ↑ 5: 10.0 ↓		1: 9.1 ↑ 2: 10.7x ↖ 3: 10.0 ↓ 4: 9.1 ↙ 5: 10.2 ↓
Serie 50	Total 0	Serie 48	Total 48
	1: 10.8x ↑ 2: 10.4 ↓ 3: 10.5x ↙ 4: 9.8 ↖ 5: 10.4 ↓		1: 9.6 ↑ 2: 10.1 ↑ 3: 10.2 ↓ 4: 10.1 ↗ 5: 9.4 ↓
Serie 49	Total 97	Serie 48	Total 145
	1: 10.4x ↗ 2: 9.7 ↓ 3: 10.8x ↑ 4: 10.3 ↑ 5: 10.0 →		1: 10.6x ↑ 2: 10.4 → 3: 10.6x ↗ 4: 8.8 ↖ 5: 10.4 ←
Serie 49	Total 194	Serie 48	Total 194
	1: 10.2 ↓ 2: 10.8x → 3: 10.4 ↖ 4: 9.9 ↓ 5: 9.8 ↓		1: 10.7x ↖ 2: 9.8 ↖ 3: 9.9 ↑ 4: 10.0 ↓ 5: 9.0 →
Serie 48	Total 242	Serie 47	Total 289
	1: 9.8 ↑ 2: 10.3 ↗ 3: 8.0 ↗ 4: 6.7 → 5: 10.6x ←		
Serie 43	Total 332		

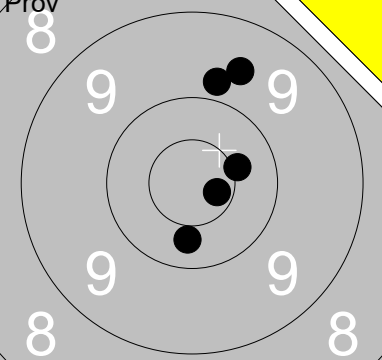
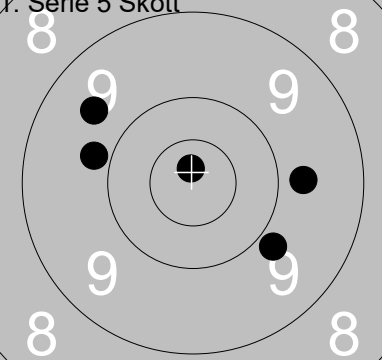
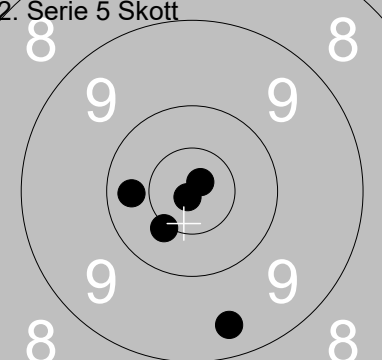
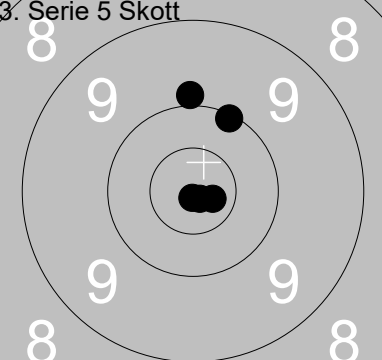
Skjutlag 3	Tavla 16	Olle Gabrielsson	
Ramselefors	Rommehed	A	Da
07.07.2019	Tavelträffen 2019	Ramselefors SKF	
Prov 	1: 10.2 ↗ 2: 10.9x ↓ 3: 10.7x ↓ 4: 10.6x ↗ 5: 10.0 ←	1. Serie 5 Skott 	1: 10.3 → 2: 10.6x ↙ 3: 10.4 → 4: 10.5x ↗ 5: 10.1 ↓
	Serie 50 Total 0		Serie 50 Total 50
2. Serie 5 Skott 	1: 10.6x ↓ 2: 10.0 → 3: 10.7x ← 4: 10.2 ↓ 5: 10.1 ←	3. Serie 5 Skott 	1: 10.4 → 2: 10.2 ↓ 3: 10.3 ← 4: 10.2 ↗ 5: 9.8 ←
	Serie 50 Total 100		Serie 49 Total 149
4. Serie 5 Skott 	1: 9.9 ↘ 2: 10.2 ↙ 3: 10.4x ↗ 4: 10.2 ↑ 5: 10.8x ↙	Prov 	1: 9.7 → 2: 10.4x ← 3: 10.5x ↑ 4: 10.2 → 5: 10.9x ↓ 6: 8.9 →
	Serie 49 Total 198		Serie 57 Total 198
5. Serie 5 Skott 	1: 10.1 ↙ 2: 10.4 → 3: 10.5x ← 4: 9.9 ↑ 5: 10.6x ↗	6. Serie 5 Skott 	1: 9.8 ↓ 2: 10.7x ↗ 3: 9.9 → 4: 9.4 ↗ 5: 10.6x ↓
	Serie 49 Total 247		Serie 47 Total 294
7. Serie 5 Skott 	1: 9.1 → 2: 4.8 ↑ 3: 7.6 ↗ 4: 7.3 ↗ 5: 10.4 ↗		
	Serie 37 Total 331		

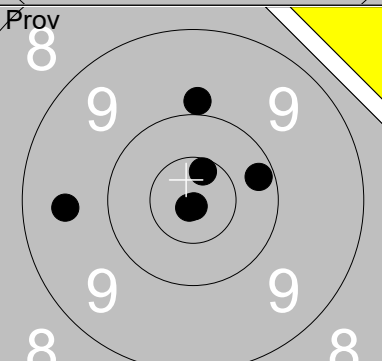
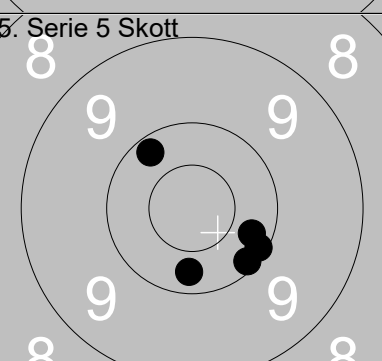
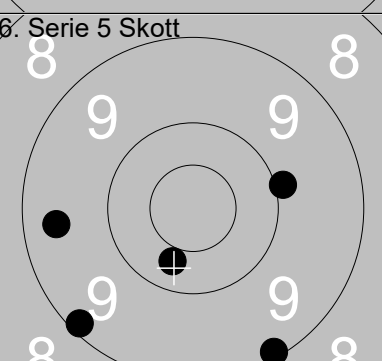
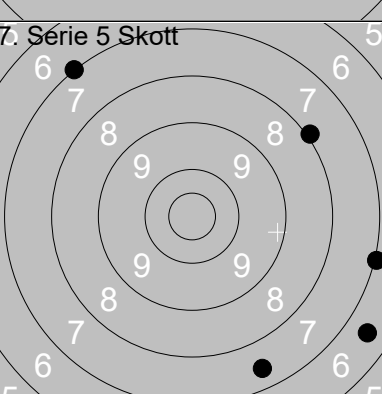
Prov 	1. Serie 5 Skott 1: 10.7x → 2: 9.8 ↑ 3: 9.6 ↑ 4: 10.4x → 5: 10.3 ↓ <hr/> Serie 48 Total 0		1: 9.7 → 2: 9.6 ↗ 3: 9.8 ← 4: 10.8x ↑ 5: 9.8 ↓ <hr/> Serie 46 Total 46
2. Serie 5 Skott 	1: 10.5x ↓ 2: 9.4 ↓ 3: 10.8x ↗ 4: 10.9x ↓ 5: 10.3 ← <hr/> Serie 49 Total 95	3. Serie 5 Skott 	1: 10.9x ↓ 2: 10.8x ↓ 3: 10.1 ↗ 4: 9.9 ↑ 5: 10.7x → <hr/> Serie 49 Total 144
4. Serie 5 Skott 	1: 10.7x ← 2: 9.4 ↗ 3: 10.3 ↓ 4: 10.0 ↗ 5: 9.8 → <hr/> Serie 48 Total 192	Prov 	1: 10.2 → 2: 9.9 ↑ 3: 10.9x ↓ 4: 10.6x ↑ 5: 9.5 ← 6: 10.9x ↓ <hr/> Serie 58 Total 192
5. Serie 5 Skott 	1: 10.1 ↓ 2: 10.1 → 3: 10.2 ↗ 4: 10.3 ↓ 5: 10.3 ↓ <hr/> Serie 50 Total 242	6. Serie 5 Skott 	1: 9.4 ← 2: 9.1 ↙ 3: 9.9 → 4: 10.3 ↓ 5: 9.1 ↓ <hr/> Serie 46 Total 288
7. Serie 5 Skott 	1: 7.0 ↗ 2: 7.0 → 3: 8.0 ↗ 4: 7.5 ↓ 5: 6.5 ↓ <hr/> Serie 35 Total 323		

Skjutlag	Tavla	Ellen Jansson			
3	19	Ramselefors	Söderala	U	Gä
07.07.2019	Tavelträffen 2019	Ramselefors SKF			
	1: 9.8 ↖ 2: 10.7x ↓ 3: 9.4 ↓ 4: 9.6 ↑ 5: 9.2 ↓		1: 6.9 ↘ 2: 10.2 ↗ 3: 10.1 ↓ 4: 10.5x ↓ 5: 10.1 ↓		
Serie	46	Serie	46		
Total	0	Total	46		
	1: 9.3 ← 2: 10.0 ↓ 3: 9.7 ↑ 4: 8.3 ↑ 5: 8.8 ←		1: 10.6x ↗ 2: 10.6x ↑ 3: 10.4x ↑ 4: 9.2 ↗ 5: 10.4 ↓		
Serie	44	Serie	49		
Total	90	Total	139		
	1: 10.4 ← 2: 8.8 ↓ 3: 9.8 ↑ 4: 10.0 ↑ 5: 9.9 ↖		1: 9.9 ↓ 2: 8.9 ↘ 3: 10.4x ↓ 4: 10.2 ↘ 5: 8.9 ↓ 6: 8.5 ↓		
Serie	46	Serie	53		
Total	185	Total	185		
	1: 9.8 ↗ 2: 10.0 ↑ 3: 9.9 ↑ 4: 8.6 → 5: 10.8x ↖		1: 10.7x ↖ 2: 9.4 ↑ 3: 9.8 ↗ 4: 9.0 ↓ 5: 9.1 →		
Serie	46	Serie	46		
Total	231	Total	277		
	1: 7.0 ↓ 2: 8.6 → 3: 10.3 ↑ 4: 9.8 ← 5: 9.6 ↓				
Serie	43				
Total	320				

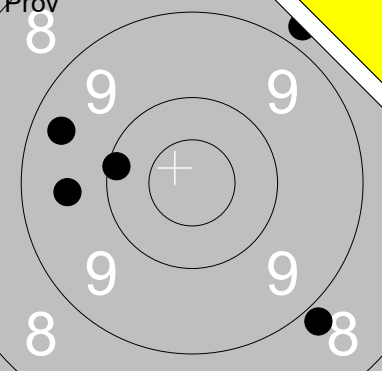
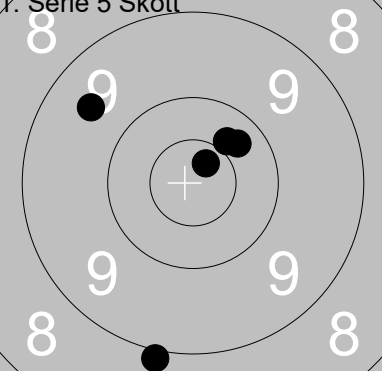
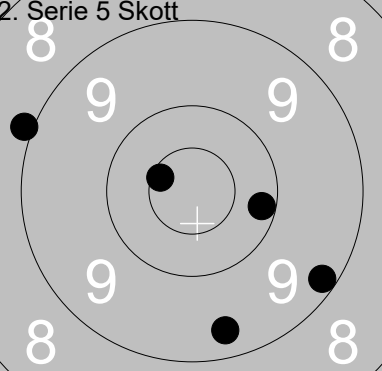
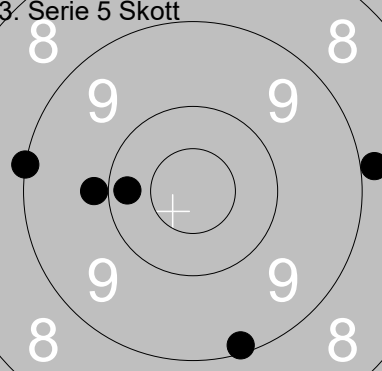
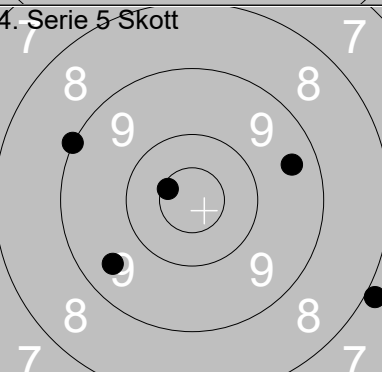
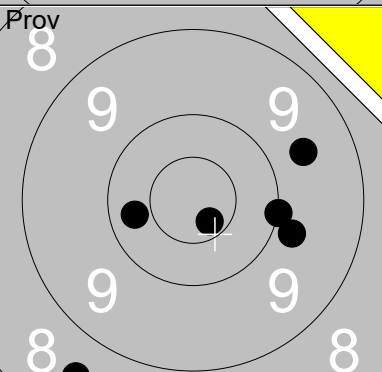
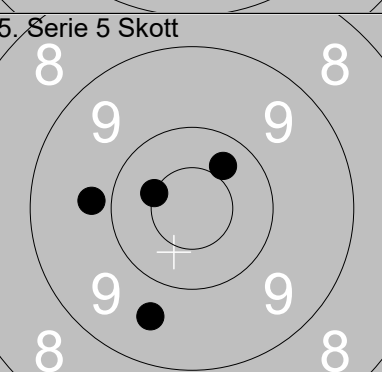
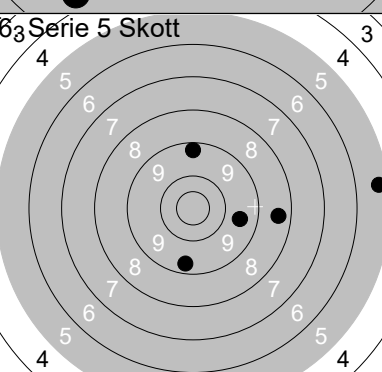
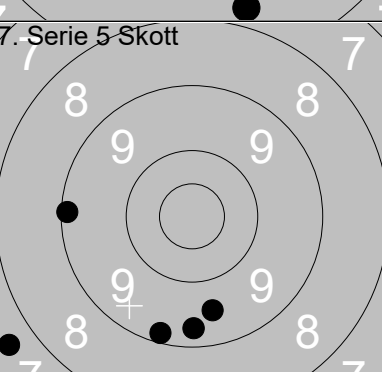
	<p>1: 9.4 ←</p> <p>2: 8.8 ↗</p> <p>3: 10.1 ←</p> <p>4: 9.6 ←</p> <p>5: 8.8 ↓</p>	<p>1. Serie 5 Skott</p> 	<p>1: 9.5 ←</p> <p>2: 10.4 ↗</p> <p>3: 8.9 ↓</p> <p>4: 10.7x ↗</p> <p>5: 10.3 ↗</p>
<p>Serie 44</p> <p>Total 0</p>		<p>Serie 47</p> <p>Total 47</p>	
<p>2. Serie 5 Skott</p> 	<p>1: 10.2 →</p> <p>2: 9.2 ↓</p> <p>3: 9.4 ↓</p> <p>4: 8.9 ↗</p> <p>5: 10.6x ↗</p>	<p>3. Serie 5 Skott</p> 	<p>1: 10.2 ←</p> <p>2: 9.9 ←</p> <p>3: 9.0 ←</p> <p>4: 8.9 →</p> <p>5: 9.1 ↓</p>
<p>Serie 46</p> <p>Total 93</p>		<p>Serie 45</p> <p>Total 138</p>	
<p>4. Serie 5 Skott</p> 	<p>1: 9.0 ←</p> <p>2: 10.6x ←</p> <p>3: 7.9 ↓</p> <p>4: 9.4 →</p> <p>5: 9.5 ↖</p>	<p>Prov</p> 	<p>1: 10.3 ←</p> <p>2: 10.0 →</p> <p>3: 9.6 →</p> <p>4: 10.7x ↓</p> <p>5: 8.6 ↓</p> <p>6: 9.8 →</p>
<p>Serie 44</p> <p>Total 182</p>		<p>Serie 56</p> <p>Total 182</p>	
<p>5. Serie 5 Skott</p> 	<p>1: 10.5x ←</p> <p>2: 10.4 ↗</p> <p>3: 8.7 ↓</p> <p>4: 9.6 ↓</p> <p>5: 9.8 ←</p>	<p>6. Serie 5 Skott</p> 	<p>1: 5.3 →</p> <p>2: 9.6 →</p> <p>3: 8.4 →</p> <p>4: 9.2 ↑</p> <p>5: 9.3 ↓</p>
<p>Serie 46</p> <p>Total 228</p>		<p>Serie 40</p> <p>Total 268</p>	
<p>7. Serie 5 Skott</p> 	<p>1: 9.1 ←</p> <p>2: 9.6 ↓</p> <p>3: 9.3 ↓</p> <p>4: 7.6 ↖</p> <p>5: 9.2 ↓</p>		
<p>Serie 43</p> <p>Total 311</p>			

Skjutlag	Tavla	Agnes Ebbhagen			
3	23	Ramselefors	Ramselefors	U	Vb
07.07.2019	Tavelträffen 2019	Ramselefors SKF			
	1: 10.1 ←		1: 9.1 ←		
	2: 10.1 ↗		2: 10.2 ←		
	3: 10.1 ↑		3: 9.3 ←		
	4: 10.8x ↙		4: 9.8 ↘		
	5: 10.2 ↑		5: 10.1 →		
Serie	50	Serie	47		
Total	0	Total	47		
	1: 10.5x ↗		1: 9.3 ↘		
	2: 10.3 ↘		2: 10.4x ↘		
	3: 8.9 ↘		3: 9.9 ↘		
	4: 9.8 ↖		4: 10.3 ←		
	5: 10.5x ↗		5: 9.9 ↑		
Serie	47	Serie	47		
Total	94	Total	141		
	1: 10.3 ←		1: 8.3 ↗		
	2: 10.5x ↑		2: 9.9 ↗		
	3: 10.6x →		3: 9.0 ↗		
	4: 10.4x ↘		4: 9.5 →		
	5: 10.4 →		5: 10.7x ↘		
Serie	50	Serie	54		
Total	191	Total	191		
	1: 9.4 ←		1: 10.2 ↘		
	2: 9.6 ←		2: 8.7 ←		
	3: 9.9 ←		3: 9.2 ↗		
	4: 8.9 ↑		4: 9.6 ↘		
	5: 10.6x ↗		5: 10.0 ←		
Serie	45	Serie	46		
Total	236	Total	282		
	1: 10.1 ↗				
	2: 10.2 ↗				
	3: 10.5x ↘				
	4: 8.6 →				
	5: 8.8 ↑				
Serie	46				
Total	328				

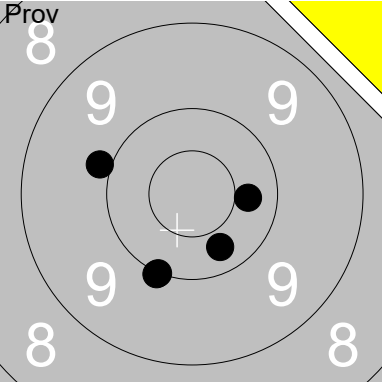
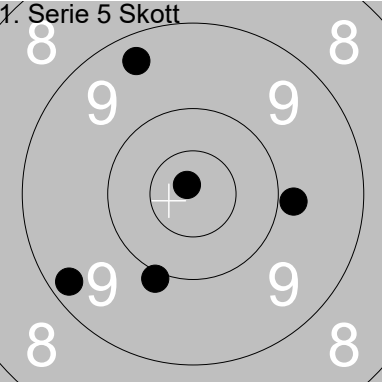
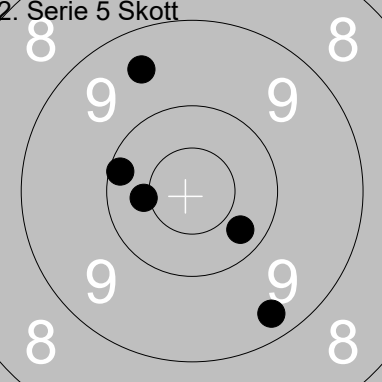
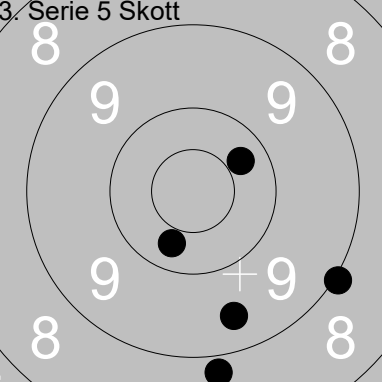
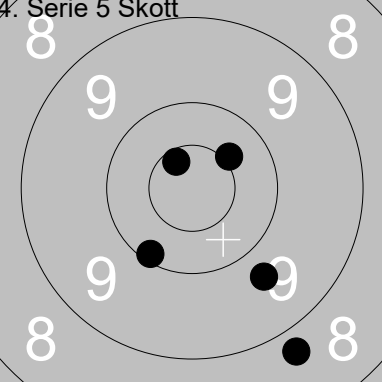
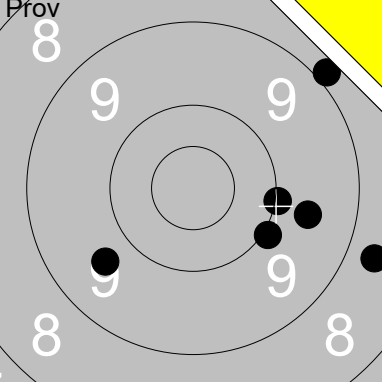
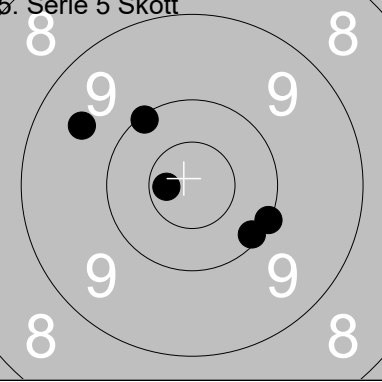
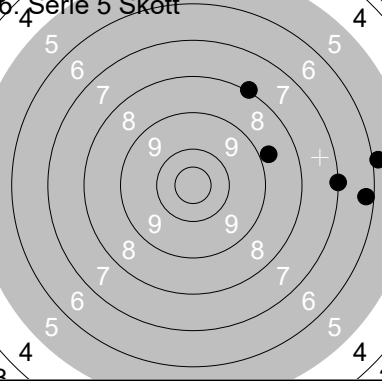
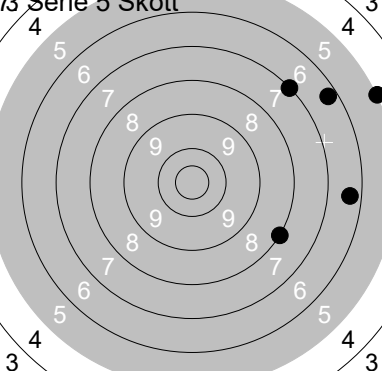
Skjutlag 4	Tavla 1	Johan Nilsson			
Ramselefors		Ramselefors		B	Vb
07.07.2019		Tavelträffen 2019		Ramselefors SKF	
	1: 10.3 → 2: 10.3 ↓ 3: 10.0 ↓ 4: 10.0 ↓ 5: 9.9 ←	1. Serie 5 Skott 	1: 9.3 ↗ 2: 9.9 ↓ 3: 10.8x ↗ 4: 9.3 ↙ 5: 9.9 →	Serie	49
Serie		49		Serie	46
Total		0		Total	46
2. Serie 5 Skott 	1: 10.3 ↓ 2: 9.5 ↗ 3: 10.4x ← 4: 10.1 ↗ 5: 9.3 ↓	3. Serie 5 Skott 	1: 10.3 ↗ 2: 9.0 → 3: 10.3 ↓ 4: 8.8 ↓ 5: 9.5 ↓	Serie	48
Serie		48		Serie	46
Total		94		Total	140
4. Serie 5 Skott 	1: 10.6x ↗ 2: 9.7 ↓ 3: 8.8 ↓ 4: 10.4x ↗ 5: 10.1 ↓	Prov 	1: 8.9 ↗ 2: 8.7 → 3: 10.0 → 4: 9.7 ↙ 5: 10.0 → 6: 9.6 →	Serie	47
Serie		47		Serie	54
Total		187		Total	187
5. Serie 5 Skott 	1: 10.7x ← 2: 10.1 ↗ 3: 9.6 ↗ 4: 10.0 ↓ 5: 10.1 ↓	6. Serie 5 Skott 	1: 8.0 ↗ 2: 5.9 → 3: 8.8 → 4: 7.0 → 5: 6.2 →	Serie	49
Serie		49		Serie	34
Total		236		Total	270
7. Serie 5 Skott 	1: 8.0 → 2: 6.4 → 3: 7.0 ↗ 4: 5.0 ↗ 5: 6.3 ↗				
Serie		32			
Total		302			

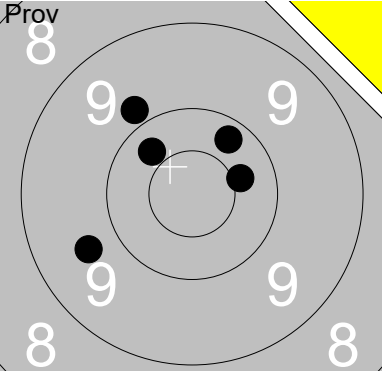
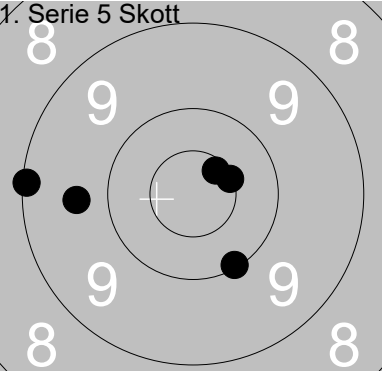
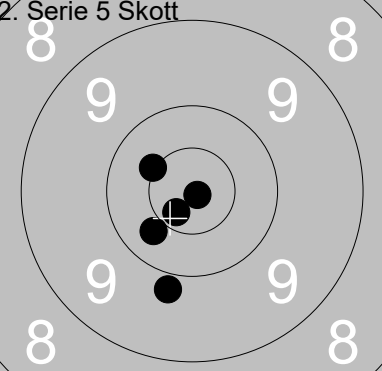
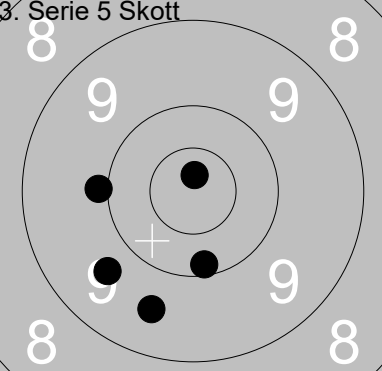
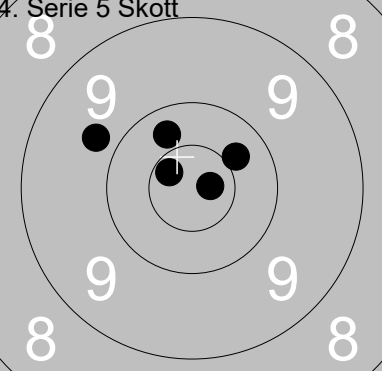
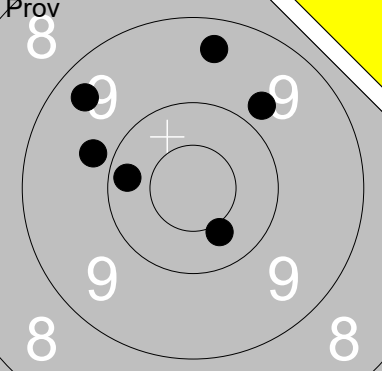
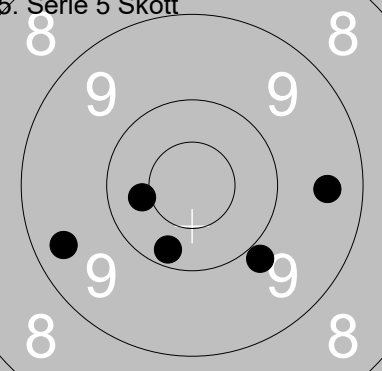
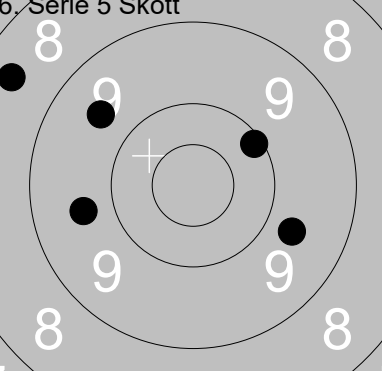
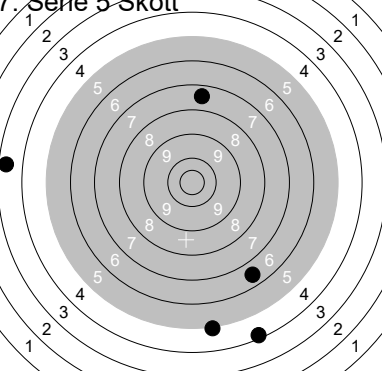
Skjutlag	Tavla	Tomas Lindblom		
4	2	Ramselefors	Kalix	B No
07.07.2019	Tavelträffen 2019	Ramselefors SKF		
	1: 9.7 ↙ 2: 10.2 ↗ 3: 10.3 ↗ 4: 10.4 → 5: 9.8 ↗		1: 10.5x → 2: 9.7 ← 3: 9.1 ← 4: 10.1 ↓ 5: 10.6x ↗	
	Serie 48		Serie 48	
	Total 0		Total 48	
	1: 10.9x → 2: 10.7x ↓ 3: 10.4 ↓ 4: 9.8 ↓ 5: 10.5x ↗		1: 9.6 ↓ 2: 10.8x ↑ 3: 10.1 ↓ 4: 9.7 ↙ 5: 9.9 ←	
	Serie 49		Serie 47	
	Total 97		Total 144	
	1: 10.7x ↙ 2: 10.4 ↗ 3: 10.8x → 4: 10.3 ↗ 5: 9.8 ↗		1: 9.8 ↗ 2: 9.4 ↑ 3: 10.4 ↓ 4: 9.4 ↗ 5: 9.8 ← 6: 10.2 ←	
	Serie 49		Serie 56	
	Total 193		Total 193	
	1: 9.4 ↙ 2: 10.4 ← 3: 10.2 ↓ 4: 9.4 → 5: 9.9 ↓		1: 9.7 → 2: 10.1 ↗ 3: 9.6 ← 4: 8.4 ↗ 5: 9.6 ↗	
	Serie 47		Serie 45	
	Total 240		Total 285	
	1: 3.3 ← 2: 7.4 ↑ 3: 5.0 ↓ 4: 6.5 ↓ 5: 4.2 ↓			
	Serie 25			
	Total 310			

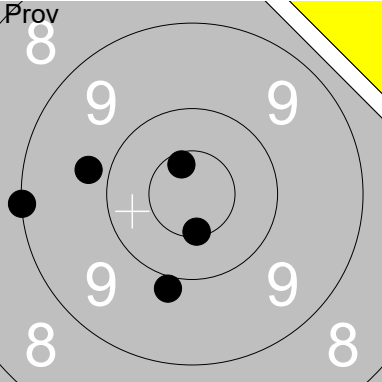
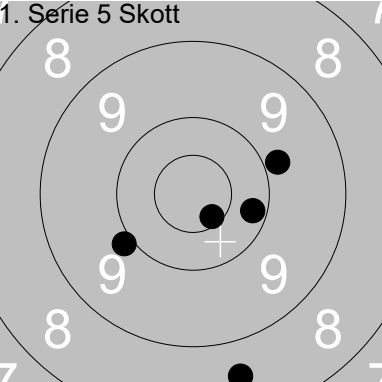
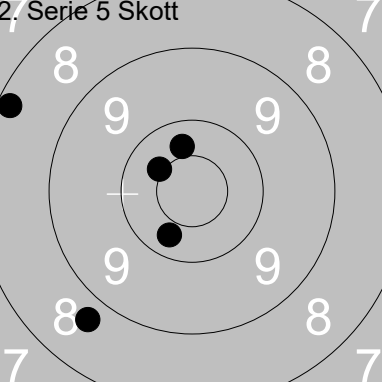
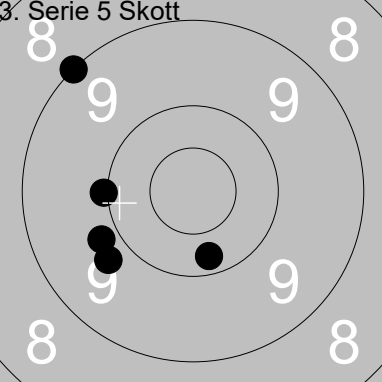
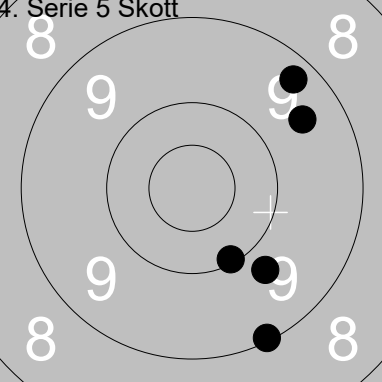
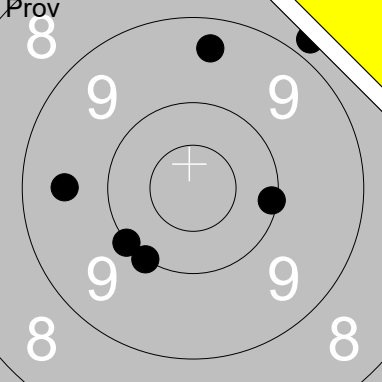
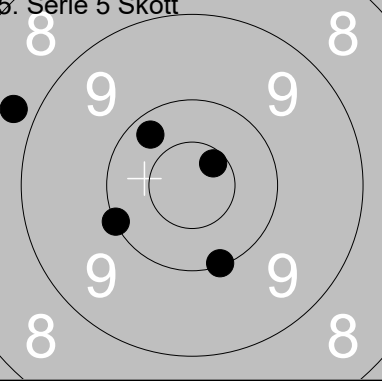
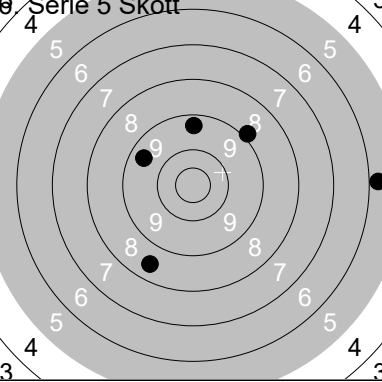
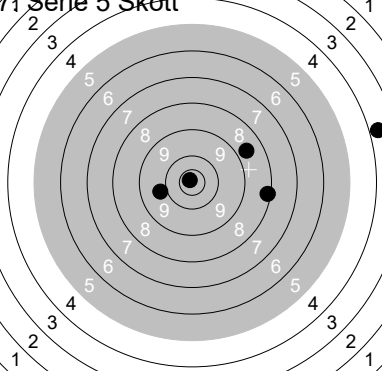
Skjutlag 4	Tavla 3	Johannes Ek			
Ramselefors		Kalix		B	No
07.07.2019		Tavelträffen 2019		Ramselefors SKF	
	<p>1: 9.0 ←</p> <p>2: 10.5x ↓</p> <p>3: 9.8 ←</p> <p>4: 9.9 ↓</p> <p>5: 10.6x ↑</p>	<p>1. Serie 5 Skott</p> 	<p>1: 10.2 →</p> <p>2: 8.6 ↓</p> <p>3: 9.8 →</p> <p>4: 9.9 ←</p> <p>5: 10.6x ↓</p>	Serie	47
Total		0		Total	46
<p>2. Serie 5 Skott</p> 	<p>1: 10.3 ↓</p> <p>2: 8.7 ↓</p> <p>3: 10.4x ↑</p> <p>4: 8.2 ←</p> <p>5: 10.4 ↑</p>	<p>3. Serie 5 Skott</p> 	<p>1: 9.0 ↖</p> <p>2: 9.8 ←</p> <p>3: 10.0 ←</p> <p>4: 9.8 ←</p> <p>5: 10.2 ↓</p>	Serie	46
Total		92		Total	47
<p>4. Serie 5 Skott</p> 	<p>1: 10.1 ↓</p> <p>2: 9.5 →</p> <p>3: 9.1 ↓</p> <p>4: 9.3 →</p> <p>5: 9.7 ↓</p>	<p>Prov</p> 	<p>1: 9.4 ↑</p> <p>2: 8.8 ↗</p> <p>3: 10.0 ↓</p> <p>4: 10.0 ←</p> <p>5: 9.5 ←</p> <p>6: 10.1 →</p>	Serie	46
Total		185		Total	56
<p>5. Serie 5 Skott</p> 	<p>1: 10.2 ↖</p> <p>2: 8.8 ←</p> <p>3: 10.0 ←</p> <p>4: 10.6x ↗</p> <p>5: 10.1 ↓</p>	<p>6. Serie 5 Skott</p> 	<p>1: 9.4 ↖</p> <p>2: 9.3 ↑</p> <p>3: 8.5 ↓</p> <p>4: 5.8 →</p> <p>5: 8.9 ↗</p>	Serie	48
Total		233		Total	39
<p>7. Serie 5 Skott</p> 	<p>1: 9.8 ←</p> <p>2: 10.8x ↗</p> <p>3: 8.6 →</p> <p>4: 3.7 →</p> <p>5: 8.1 →</p>				
Total		310			

Skjutlag	Tavla	Anders Andersson			
4	4	Ramselefors	Hammerdal	B	Jä
07.07.2019	Tavelträffen 2019	Ramselefors SKF			
	1: 9.3 ↖ 2: 9.3 ↗ 3: 9.7 ↓ 4: 9.4 ← 5: 9.0 ↓	1. Serie 5 Skott		1: 9.7 ↓ 2: 10.8x ↘ 3: 9.6 ↑ 4: 10.1 ↘ 5: 9.9 ↘	
	Serie 45 Total 0			Serie 47 Total 47	
	1: 10.8x ← 2: 10.1 ↖ 3: 7.8 ↑ 4: 10.3 ↑ 5: 9.5 ↓	3. Serie 5 Skott		1: 9.8 → 2: 8.7 ↗ 3: 9.8 ↑ 4: 9.3 → 5: 9.8 →	
	Serie 46 Total 93			Serie 44 Total 137	
	1: 10.0 ↑ 2: 9.2 → 3: 9.9 ↓ 4: 10.1 ↓ 5: 9.2 ←	Prov		1: 10.2 ← 2: 10.4 ↑ 3: 10.1 → 4: 8.8 ↗ 5: 9.6 ← 6: 9.9 ↖	
	Serie 47 Total 184			Serie 56 Total 184	
	1: 10.5x ↑ 2: 8.5 ↓ 3: 10.1 ↓ 4: 9.9 ← 5: 10.1 ↘	6. Serie 5 Skott		1: 9.9 ↓ 2: 9.0 ↗ 3: 8.2 ↖ 4: 7.8 ↗ 5: 7.7 ↖	
	Serie 47 Total 231			Serie 40 Total 271	
	1: 9.2 ↘ 2: 6.1 ↗ 3: 10.1 ↓ 4: 5.7 ↘ 5: 5.9 ←				
	Serie 35 Total 306				

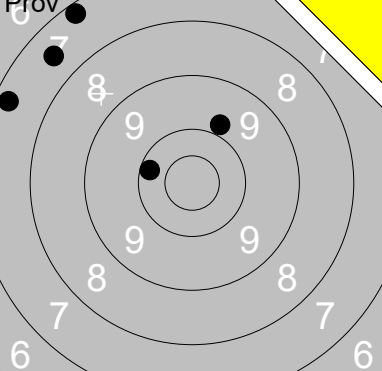
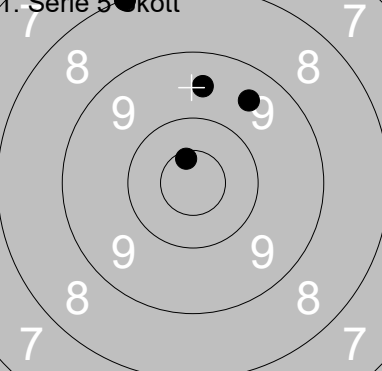
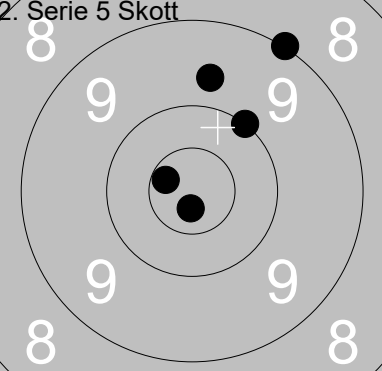
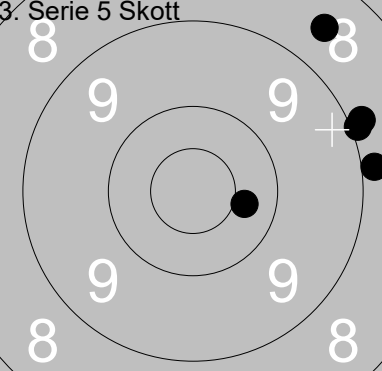
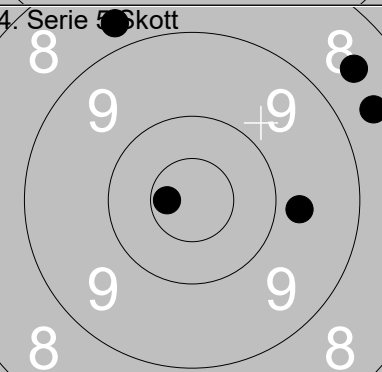
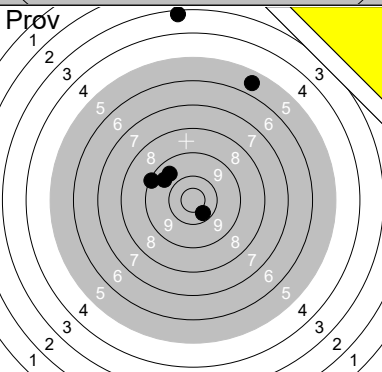
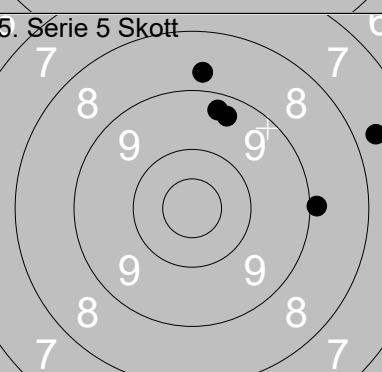
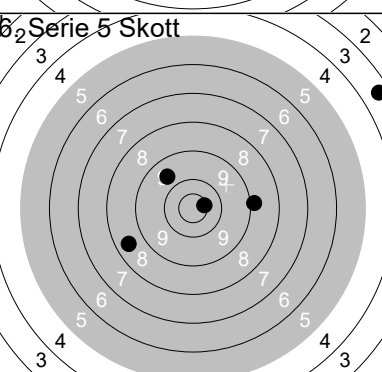
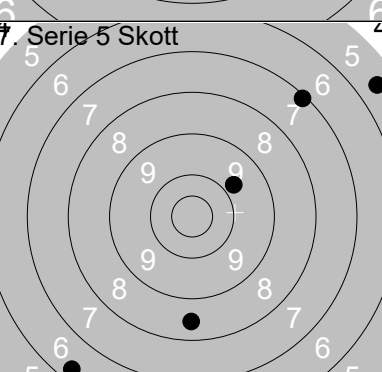
 <p>Prov</p>	<p>1: 7.2 ↗ 2: 9.8 ↑ 3: 7.3 ↖ 4: 7.5 ↗ 5: 10.2 ↖</p>	 <p>1. Serie 5 Skott</p>	<p>1: 8.0 ↗ 2: 9.5 ↑ 3: 10.6x ↗ 4: 9.5 ↗</p>
<p>Serie 40 Total 0</p>		<p>Serie 36 Total 36</p>	
 <p>2. Serie 5 Skott</p>	<p>1: 10.0 ↗ 2: 10.8x ↓ 3: 9.0 ↗ 4: 9.7 ↑ 5: 10.6x ↖</p>	 <p>3. Serie 5 Skott</p>	<p>1: 10.4 → 2: 8.9 → 3: 8.9 → 4: 8.6 ↗ 5: 9.0 →</p>
<p>Serie 48 Total 84</p>		<p>Serie 43 Total 127</p>	
 <p>4. Serie 5 Skott</p>	<p>1: 8.6 → 2: 10.7x ↖ 3: 8.5 ↗ 4: 9.7 → 5: 8.7 ↗</p>	 <p>Prov</p>	<p>1: 3.2 ↑ 2: 5.5 ↑ 3: 9.1 ↖ 4: 10.3 ↓ 5: 9.5 ↗ 6: 9.6 ↗</p>
<p>Serie 43 Total 170</p>		<p>Serie 45 Total 170</p>	
 <p>5. Serie 5 Skott</p>	<p>1: 8.7 ↑ 2: 7.7 → 3: 8.9 → 4: 9.3 ↑ 5: 9.4 ↑</p>	 <p>6. Serie 5 Skott</p>	<p>1: 8.9 → 2: 9.6 ↖ 3: 3.4 ↗ 4: 8.5 ↖ 5: 10.6x →</p>
<p>Serie 41 Total 211</p>		<p>Serie 38 Total 249</p>	
 <p>7. Serie 5 Skott</p>	<p>1: 7.1 ↗ 2: 8.5 ↓ 3: 9.8 ↗ 4: 5.5 ↗ 5: 6.3 ↖</p>		
<p>Serie 35 Total 284</p>			

07.07.2019	Tavelträffen 2019	Ramselefors SKF
------------	-------------------	-----------------

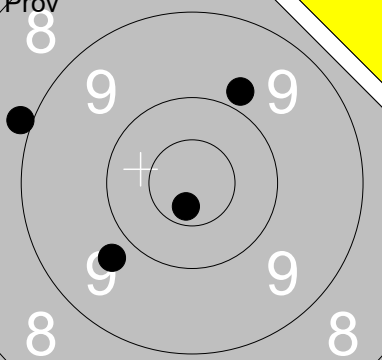
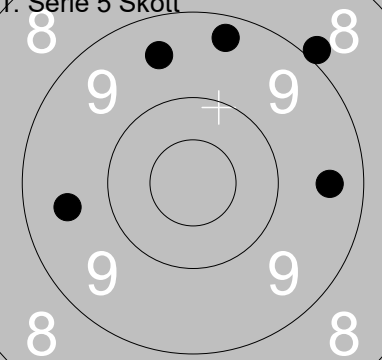
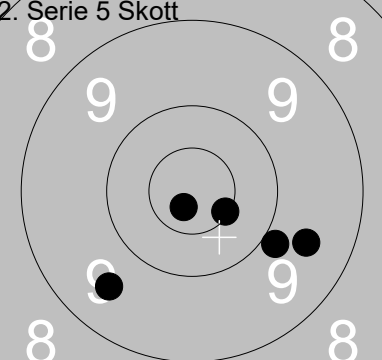
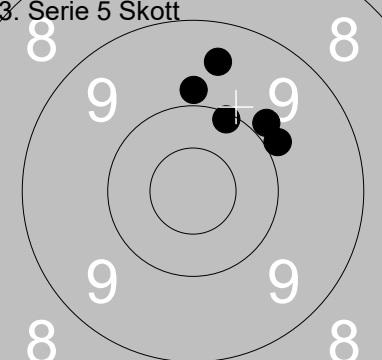
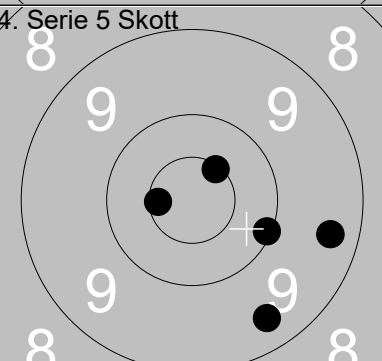
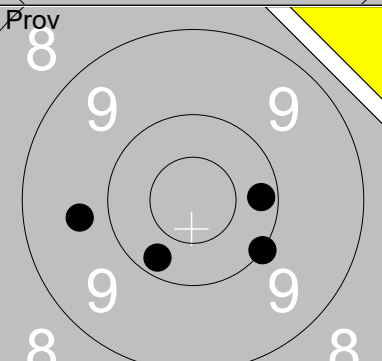
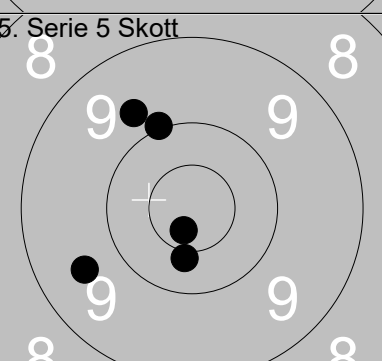
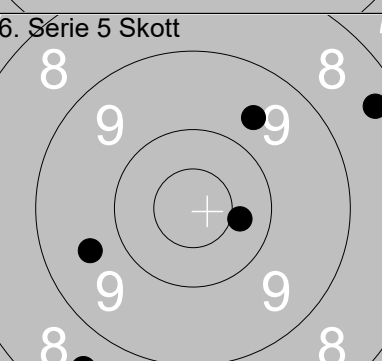
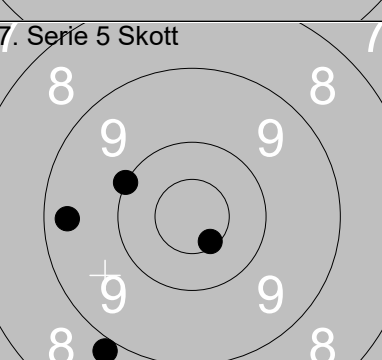
<p>Prov</p> 	<p>1: 8.9 ← 2: 10.7x ↓ 3: 9.8 ↑ 4: 9.7 ↙</p>	<p>1. Serie 5 Skott</p> 	<p>1: 9.5 ← 2: 9.5 ↑ 3: 9.3 ↑ 4: 9.4 → 5: 8.9 ↗</p>
Serie 36	Total 0	Serie 44	Total 44
<p>2. Serie 5 Skott</p> 	<p>1: 9.5 ↓ 2: 10.5x ↘ 3: 10.8x ↓ 4: 9.9 ↘ 5: 9.6 ↘</p>	<p>3. Serie 5 Skott</p> 	<p>1: 9.9 ↗ 2: 10.1 ↑ 3: 9.5 ↑ 4: 9.8 ↑ 5: 9.9 ↗</p>
Serie 47	Total 91	Serie 46	Total 137
<p>4. Serie 5 Skott</p> 	<p>1: 10.5x ↗ 2: 10.6x ← 3: 10.1 → 4: 9.4 ↓ 5: 9.4 →</p>	<p>Prov</p> 	<p>1: 9.7 ← 2: 10.2 ↓ 3: 10.2 → 4: 10.0 ↘</p>
Serie 48	Total 185	Serie 39	Total 185
<p>5. Serie 5 Skott</p> 	<p>1: 10.0 ↑ 2: 9.7 ↗ 3: 10.4 ↓ 4: 9.6 ← 5: 10.7x ↓</p>	<p>6. Serie 5 Skott</p> 	<p>1: 8.4 ↗ 2: 8.6 ↓ 3: 10.4 → 4: 9.6 ← 5: 9.6 ↑</p>
Serie 48	Total 233	Serie 44	Total 277
<p>7. Serie 5 Skott</p> 	<p>1: 10.0 ← 2: 10.6x ↓ 3: 9.3 ← 4: 8.9 ↓ 5: 7.6 ↙</p>	<p>7</p>	
Serie 44	Total 321		

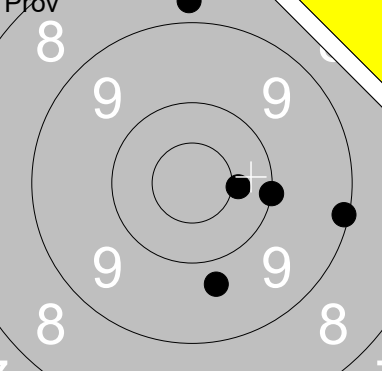
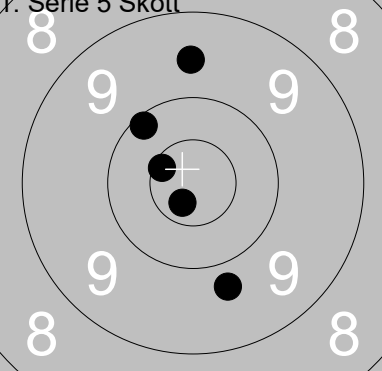
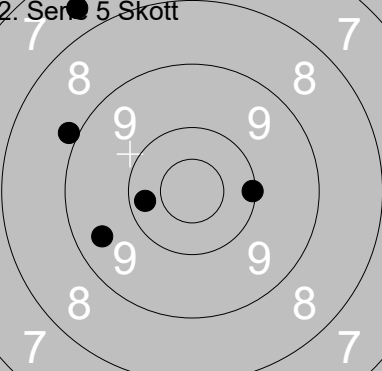
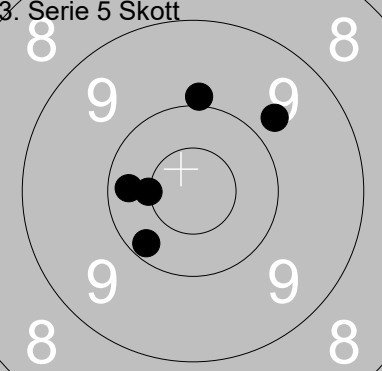
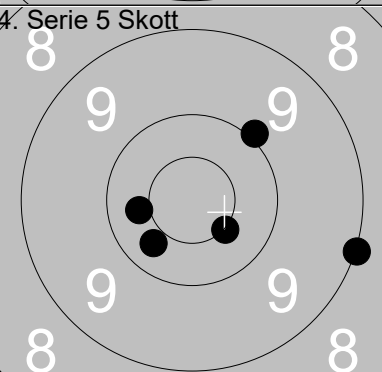
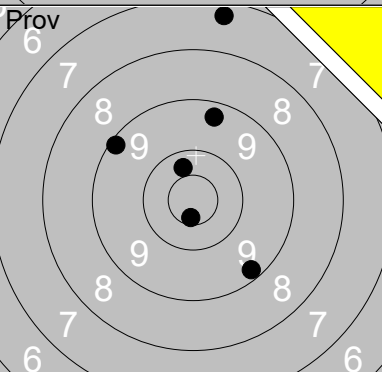
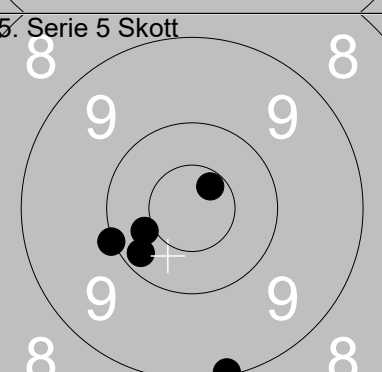
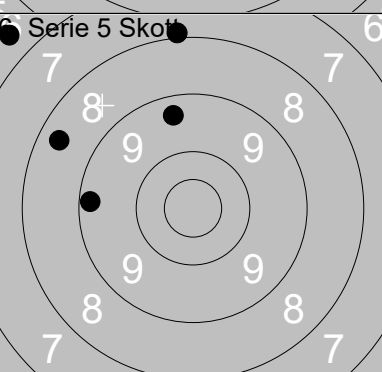
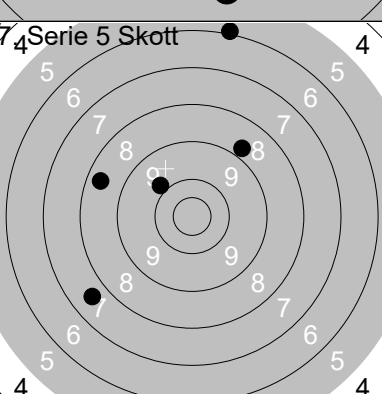
	<p>1: 8.8 ↑</p> <p>2: 9.7 ↓</p> <p>3: 10.0 →</p> <p>4: 9.1 →</p> <p>5: 10.4 →</p> <hr/> <p>Serie 46</p> <p>Total 0</p>	<p>1. Serie 5 Skott</p> 	<p>1: 9.6 ↑</p> <p>2: 10.7x ↓</p> <p>3: 10.6x ↖</p> <p>4: 9.8 ↓</p> <p>5: 10.1 ↗</p> <hr/> <p>Serie 48</p> <p>Total 48</p>
<p>2. Serie 5 Skott</p> 	<p>1: 8.9 ↖</p> <p>2: 9.4 ↖</p> <p>3: 7.6 ↗</p> <p>4: 10.3 ↖</p> <p>5: 10.1 →</p> <hr/> <p>Serie 44</p> <p>Total 92</p>	<p>3. Serie 5 Skott</p> 	<p>1: 9.7 ↗</p> <p>2: 10.2 ↘</p> <p>3: 10.3 ↖</p> <p>4: 9.9 ↑</p> <p>5: 10.5x ↖</p> <hr/> <p>Serie 48</p> <p>Total 140</p>
<p>4. Serie 5 Skott</p> 	<p>1: 10.4 ↖</p> <p>2: 10.5x ↘</p> <p>3: 10.0 ↗</p> <p>4: 10.3 ↘</p> <p>5: 9.0 →</p> <hr/> <p>Serie 49</p> <p>Total 189</p>	<p>Prov</p> 	<p>1: 9.3 ↑</p> <p>2: 9.2 ↘</p> <p>3: 10.3 ↗</p> <p>4: 10.6x ↓</p> <p>5: 7.3 ↑</p> <p>6: 9.1 ↖</p> <hr/> <p>Serie 54</p> <p>Total 189</p>
<p>5. Serie 5 Skott</p> 	<p>1: 10.0 ↖</p> <p>2: 10.4 ↖</p> <p>3: 10.2 ↖</p> <p>4: 10.6x ↗</p> <p>5: 9.1 ↓</p> <hr/> <p>Serie 49</p> <p>Total 238</p>	<p>6. Serie 5 Skott</p> 	<p>1: 6.6 ↖</p> <p>2: 9.4 ↑</p> <p>3: 9.2 ↖</p> <p>4: 8.4 ↖</p> <p>5: 7.9 ↑</p> <hr/> <p>Serie 39</p> <p>Total 277</p>
<p>7. Serie 5 Skott</p> 	<p>1: 6.0 ↑</p> <p>2: 9.8 ↗</p> <p>3: 8.4 ↖</p> <p>4: 7.6 ↘</p> <p>5: 8.8 ↗</p> <hr/> <p>Serie 38</p> <p>Total 315</p>		

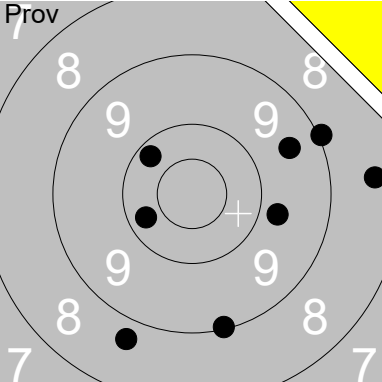
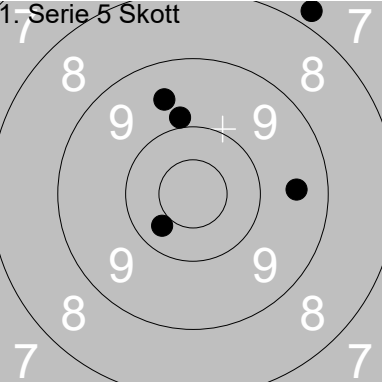
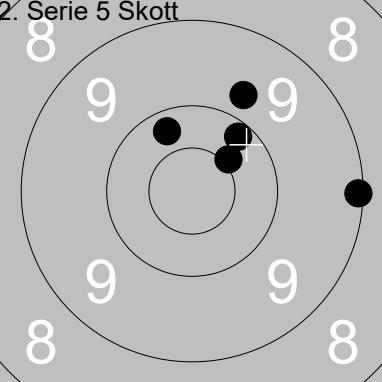
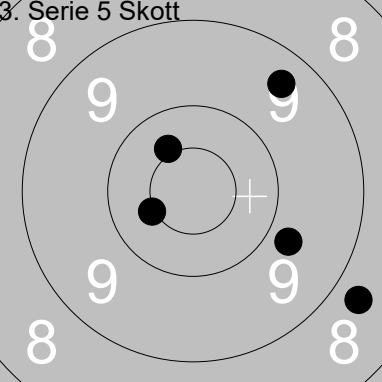
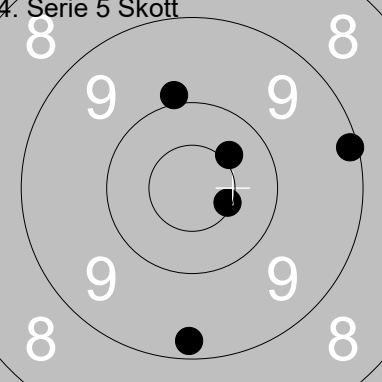
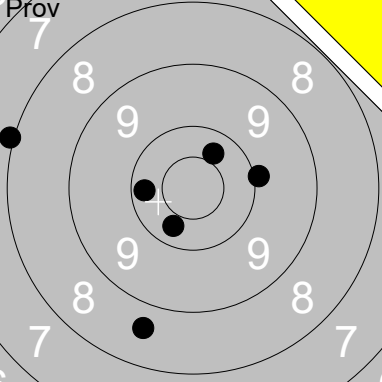
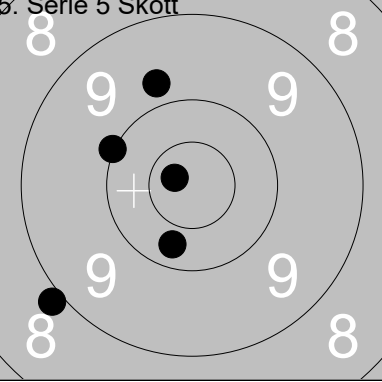
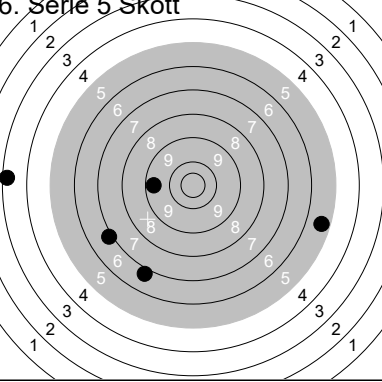
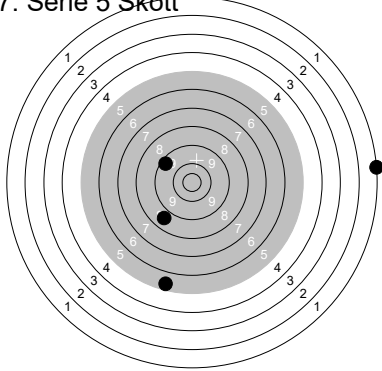
Skjutlag 4	Tavla 8	Emil Björndahl	
Ramselefors	Kvistbro	B	Ör
07.07.2019	Tavelträffen 2019	Ramselefors SKF	
	1: 10.2 ↖ 2: 9.5 → 3: 9.8 → 4: 8.4 → 5: 9.0 → 6: 9.1 ↓ 7: 8.7 ↓ 8: 10.3 ← Serie 72 Total 0		1: 9.9 ↑ 2: 9.6 ↑ 3: 9.5 → 4: 7.8 ↗ 5: 10.3 ↙ Serie 44 Total 44
	1: 9.8 ↗ 2: 10.4x ↗ 3: 9.1 → 4: 10.3 ↑ 5: 10.2 ↗ Serie 48 Total 92		1: 8.7 ↘ 2: 9.8 ↘ 3: 9.4 ↗ 4: 10.4x ↑ 5: 10.5x ← Serie 46 Total 138
	1: 10.5x → 2: 9.9 ↑ 3: 9.1 → 4: 10.4 ↗ 5: 9.2 ↓ Serie 47 Total 185		1: 10.3 ↓ 2: 10.3 ↗ 3: 10.0 → 4: 10.2 ← 5: 8.0 ← 6: 8.6 ↓ Serie 56 Total 185
	1: 10.7x ← 2: 10.0 ← 3: 10.3 ↓ 4: 8.9 ← 5: 9.8 ↑ Serie 47 Total 232		1: 6.8 ↓ 2: 9.4 ← 3: 3.2 ← 4: 5.4 → 5: 6.9 ← Serie 29 Total 261
	1: 0.0 ↑ 2: 5.4 ↓ 3: 8.6 ↙ 4: 9.3 ↖ 5: 1.0 → Serie 23 Total 284		

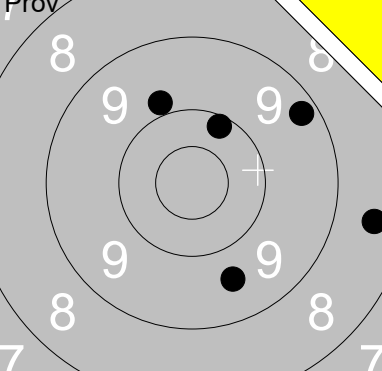
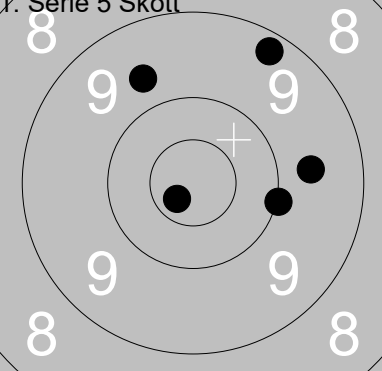
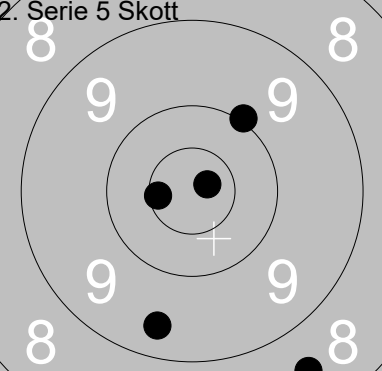
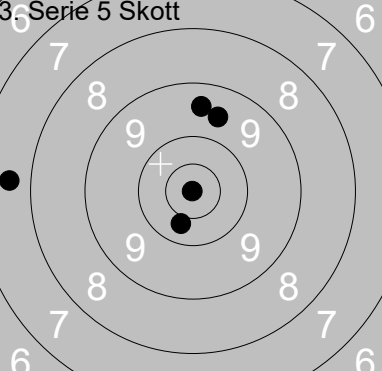
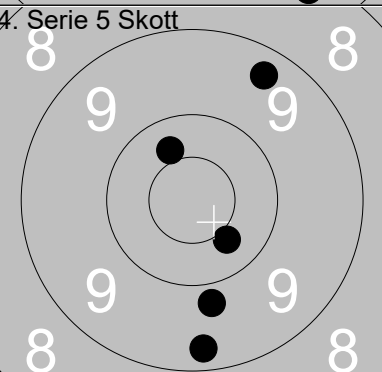
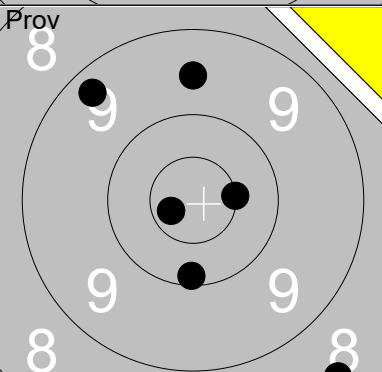
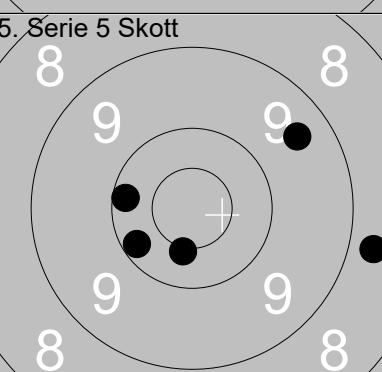
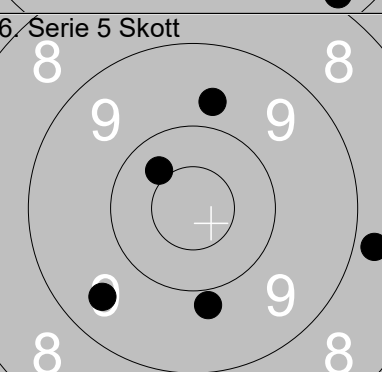
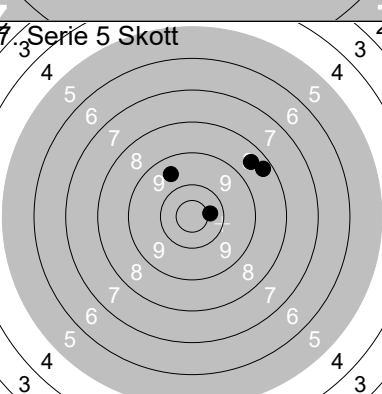
 <p>Prov</p>	<table border="1" style="width:100%; border-collapse: collapse;"> <tr><td>1:</td><td>9.9</td><td>↗</td></tr> <tr><td>2:</td><td>9.6</td><td>↘</td></tr> <tr><td>3:</td><td>10.2</td><td>↗</td></tr> <tr><td>4:</td><td>9.2</td><td>↗</td></tr> <tr><td>5:</td><td>8.5</td><td>→</td></tr> <tr><td>Serie</td><td>45</td><td></td></tr> <tr><td>Total</td><td>0</td><td></td></tr> </table>	1:	9.9	↗	2:	9.6	↘	3:	10.2	↗	4:	9.2	↗	5:	8.5	→	Serie	45		Total	0		 <p>1. Serie 5 Skott</p>	<table border="1" style="width:100%; border-collapse: collapse;"> <tr><td>1:</td><td>9.7</td><td>↗</td></tr> <tr><td>2:</td><td>9.3</td><td>↗</td></tr> <tr><td>3:</td><td>10.0</td><td>→</td></tr> <tr><td>4:</td><td>10.7x</td><td>↘</td></tr> <tr><td>5:</td><td>9.6</td><td>→</td></tr> <tr><td>Serie</td><td>47</td><td></td></tr> <tr><td>Total</td><td>47</td><td></td></tr> </table>	1:	9.7	↗	2:	9.3	↗	3:	10.0	→	4:	10.7x	↘	5:	9.6	→	Serie	47		Total	47				
1:	9.9	↗																																														
2:	9.6	↘																																														
3:	10.2	↗																																														
4:	9.2	↗																																														
5:	8.5	→																																														
Serie	45																																															
Total	0																																															
1:	9.7	↗																																														
2:	9.3	↗																																														
3:	10.0	→																																														
4:	10.7x	↘																																														
5:	9.6	→																																														
Serie	47																																															
Total	47																																															
 <p>2. Serie 5 Skott</p>	<table border="1" style="width:100%; border-collapse: collapse;"> <tr><td>1:</td><td>10.0</td><td>↗</td></tr> <tr><td>2:</td><td>10.8x</td><td>→</td></tr> <tr><td>3:</td><td>8.5</td><td>↘</td></tr> <tr><td>4:</td><td>10.6x</td><td>←</td></tr> <tr><td>5:</td><td>9.4</td><td>↘</td></tr> <tr><td>Serie</td><td>47</td><td></td></tr> <tr><td>Total</td><td>94</td><td></td></tr> </table>	1:	10.0	↗	2:	10.8x	→	3:	8.5	↘	4:	10.6x	←	5:	9.4	↘	Serie	47		Total	94		 <p>3. Serie 5 Skott</p>	<table border="1" style="width:100%; border-collapse: collapse;"> <tr><td>1:</td><td>9.5</td><td>↗</td></tr> <tr><td>2:</td><td>9.6</td><td>↗</td></tr> <tr><td>3:</td><td>10.9x</td><td>←</td></tr> <tr><td>4:</td><td>7.6</td><td>←</td></tr> <tr><td>5:</td><td>10.4</td><td>↘</td></tr> <tr><td>Serie</td><td>45</td><td></td></tr> <tr><td>Total</td><td>139</td><td></td></tr> </table>	1:	9.5	↗	2:	9.6	↗	3:	10.9x	←	4:	7.6	←	5:	10.4	↘	Serie	45		Total	139				
1:	10.0	↗																																														
2:	10.8x	→																																														
3:	8.5	↘																																														
4:	10.6x	←																																														
5:	9.4	↘																																														
Serie	47																																															
Total	94																																															
1:	9.5	↗																																														
2:	9.6	↗																																														
3:	10.9x	←																																														
4:	7.6	←																																														
5:	10.4	↘																																														
Serie	45																																															
Total	139																																															
 <p>4. Serie 5 Skott</p>	<table border="1" style="width:100%; border-collapse: collapse;"> <tr><td>1:</td><td>9.4</td><td>↗</td></tr> <tr><td>2:</td><td>10.4</td><td>↘</td></tr> <tr><td>3:</td><td>9.8</td><td>↘</td></tr> <tr><td>4:</td><td>9.3</td><td>↘</td></tr> <tr><td>5:</td><td>10.4</td><td>↗</td></tr> <tr><td>Serie</td><td>47</td><td></td></tr> <tr><td>Total</td><td>186</td><td></td></tr> </table>	1:	9.4	↗	2:	10.4	↘	3:	9.8	↘	4:	9.3	↘	5:	10.4	↗	Serie	47		Total	186		 <p>Prov</p>	<table border="1" style="width:100%; border-collapse: collapse;"> <tr><td>1:</td><td>9.3</td><td>↗</td></tr> <tr><td>2:</td><td>10.5x</td><td>→</td></tr> <tr><td>3:</td><td>8.4</td><td>↘</td></tr> <tr><td>4:</td><td>10.7x</td><td>←</td></tr> <tr><td>5:</td><td>10.1</td><td>↘</td></tr> <tr><td>6:</td><td>9.6</td><td>↗</td></tr> <tr><td>Serie</td><td>56</td><td></td></tr> <tr><td>Total</td><td>186</td><td></td></tr> </table>	1:	9.3	↗	2:	10.5x	→	3:	8.4	↘	4:	10.7x	←	5:	10.1	↘	6:	9.6	↗	Serie	56		Total	186	
1:	9.4	↗																																														
2:	10.4	↘																																														
3:	9.8	↘																																														
4:	9.3	↘																																														
5:	10.4	↗																																														
Serie	47																																															
Total	186																																															
1:	9.3	↗																																														
2:	10.5x	→																																														
3:	8.4	↘																																														
4:	10.7x	←																																														
5:	10.1	↘																																														
6:	9.6	↗																																														
Serie	56																																															
Total	186																																															
 <p>5. Serie 5 Skott</p>	<table border="1" style="width:100%; border-collapse: collapse;"> <tr><td>1:</td><td>10.2</td><td>↖</td></tr> <tr><td>2:</td><td>8.7</td><td>→</td></tr> <tr><td>3:</td><td>9.4</td><td>↗</td></tr> <tr><td>4:</td><td>10.2</td><td>←</td></tr> <tr><td>5:</td><td>10.4x</td><td>↘</td></tr> <tr><td>Serie</td><td>47</td><td></td></tr> <tr><td>Total</td><td>233</td><td></td></tr> </table>	1:	10.2	↖	2:	8.7	→	3:	9.4	↗	4:	10.2	←	5:	10.4x	↘	Serie	47		Total	233		 <p>6. Serie 5 Skott</p>	<table border="1" style="width:100%; border-collapse: collapse;"> <tr><td>1:</td><td>9.5</td><td>↖</td></tr> <tr><td>2:</td><td>8.8</td><td>→</td></tr> <tr><td>3:</td><td>9.8</td><td>↘</td></tr> <tr><td>4:</td><td>10.4</td><td>↗</td></tr> <tr><td>5:</td><td>9.7</td><td>↗</td></tr> <tr><td>Serie</td><td>45</td><td></td></tr> <tr><td>Total</td><td>278</td><td></td></tr> </table>	1:	9.5	↖	2:	8.8	→	3:	9.8	↘	4:	10.4	↗	5:	9.7	↗	Serie	45		Total	278				
1:	10.2	↖																																														
2:	8.7	→																																														
3:	9.4	↗																																														
4:	10.2	←																																														
5:	10.4x	↘																																														
Serie	47																																															
Total	233																																															
1:	9.5	↖																																														
2:	8.8	→																																														
3:	9.8	↘																																														
4:	10.4	↗																																														
5:	9.7	↗																																														
Serie	45																																															
Total	278																																															
 <p>7. Serie 5 Skott</p>	<table border="1" style="width:100%; border-collapse: collapse;"> <tr><td>1:</td><td>8.3</td><td>↗</td></tr> <tr><td>2:</td><td>8.5</td><td>↗</td></tr> <tr><td>3:</td><td>9.5</td><td>↗</td></tr> <tr><td>4:</td><td>5.1</td><td>↘</td></tr> <tr><td>5:</td><td>10.4x</td><td>→</td></tr> <tr><td>Serie</td><td>40</td><td></td></tr> <tr><td>Total</td><td>318</td><td></td></tr> </table>	1:	8.3	↗	2:	8.5	↗	3:	9.5	↗	4:	5.1	↘	5:	10.4x	→	Serie	40		Total	318																											
1:	8.3	↗																																														
2:	8.5	↗																																														
3:	9.5	↗																																														
4:	5.1	↘																																														
5:	10.4x	→																																														
Serie	40																																															
Total	318																																															

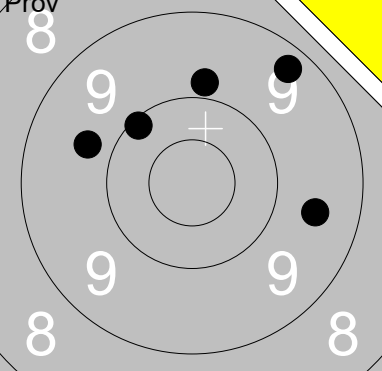
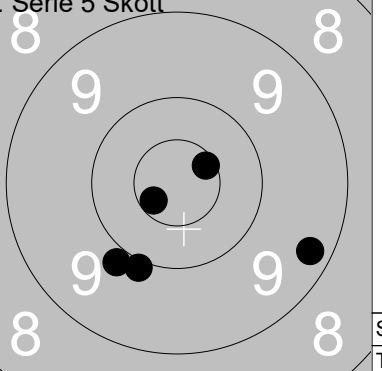
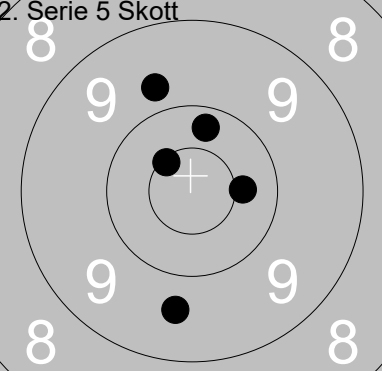
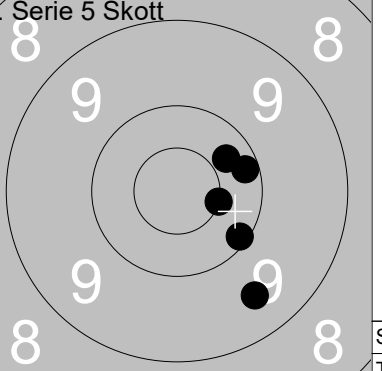
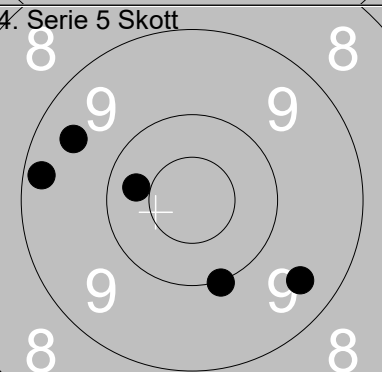
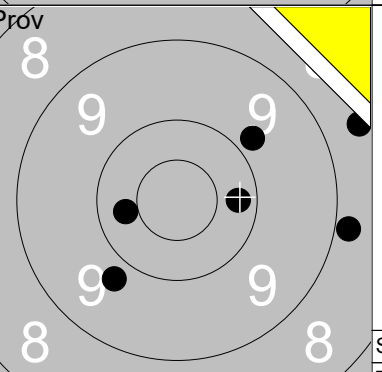
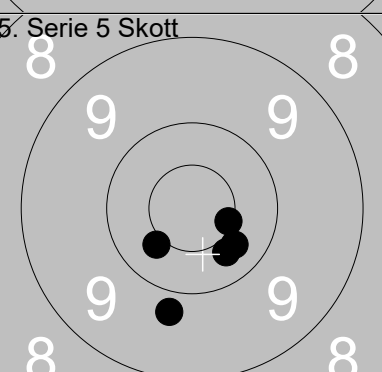
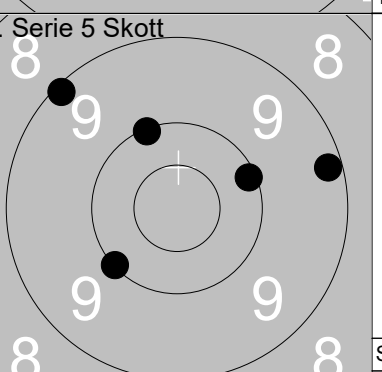
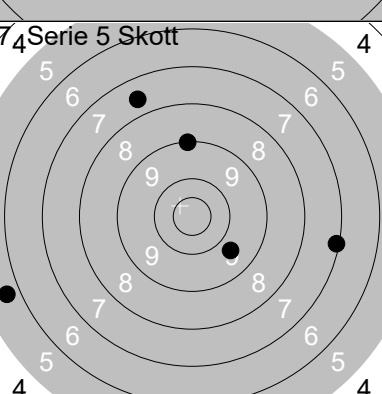
 <p>Prov</p>	<p>1: 9.6 →</p> <p>2: 10.1 ↗</p> <p>3: 9.7 ↖</p> <p>4: 9.3 ↗</p> <p>5: 9.8 ↑</p>	<p>1. Serie 5 Skott</p>  <p>1: 9.9 ↘</p> <p>2: 9.9 ↘</p> <p>3: 9.3 →</p> <p>4: 10.6x ↗</p> <p>5: 10.6x ↖</p>
Serie 46	Total 0	Serie 47
Total 0	Total 0	Total 47
<p>2. Serie 5 Skott</p> 	<p>1: 9.7 ↗</p> <p>2: 9.6 ↓</p> <p>3: 10.5x ↗</p> <p>4: 10.3 ↑</p> <p>5: 10.4 →</p>	<p>3. Serie 5 Skott</p>  <p>1: 9.5 ↘</p> <p>2: 10.5x →</p> <p>3: 10.2 →</p> <p>4: 10.1 ↘</p> <p>5: 10.3 ↗</p>
Serie 48	Total 95	Serie 49
Total 95	Total 95	Total 144
<p>4. Serie 5 Skott</p> 	<p>1: 9.5 ↖</p> <p>2: 9.5 ↓</p> <p>3: 9.2 ↖</p> <p>4: 10.0 ↓</p> <p>5: 10.3 ↖</p>	<p>Prov</p>  <p>1: 8.9 →</p> <p>2: 10.2 →</p> <p>3: 9.8 ↘</p> <p>4: 10.3 ←</p> <p>5: 9.8 ↗</p> <p>6: 8.6 →</p>
Serie 47	Total 191	Serie 54
Total 191	Total 191	Total 191
<p>5. Serie 5 Skott</p> 	<p>1: 9.8 ↓</p> <p>2: 10.3 ↓</p> <p>3: 10.5x →</p> <p>4: 10.3 ↓</p> <p>5: 10.4 ↘</p>	<p>6. Serie 5 Skott</p>  <p>1: 9.1 ↖</p> <p>2: 10.0 ↘</p> <p>3: 10.1 ↗</p> <p>4: 9.2 →</p> <p>5: 10.1 →</p>
Serie 49	Total 240	Serie 48
Total 240	Total 240	Total 288
<p>7. Serie 5 Skott</p> 	<p>1: 9.0 ↑</p> <p>2: 7.6 ↗</p> <p>3: 9.7 ↓</p> <p>4: 7.1 →</p> <p>5: 5.7 ↖</p>	
Serie 37	Total 325	
Total 325	Total 325	

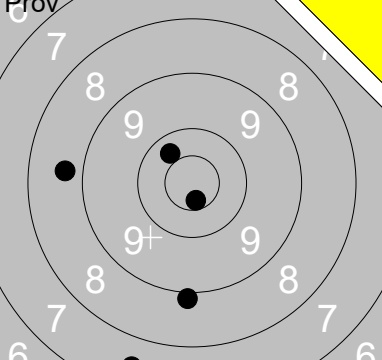
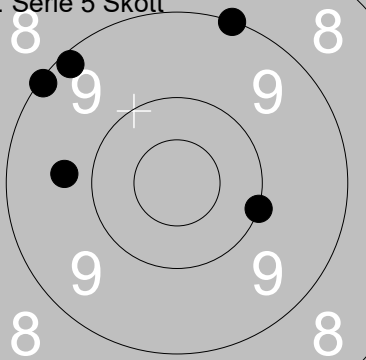
	<p>1: 8.7 ← 2: 7.5 ↓ 3: 8.9 ↓ 4: 10.3 ↗ 5: 10.7x ↓</p>	<p>1. Serie 5 Skott</p> 	<p>1: 9.1 ↗ 2: 9.7 ← 3: 9.2 ↗ 4: 9.0 ↑ 5: 10.0 →</p>
Serie 43	Total 0	Serie 46	Total 46

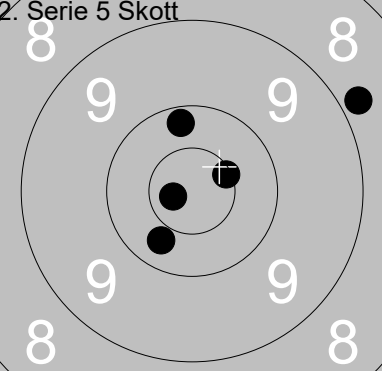
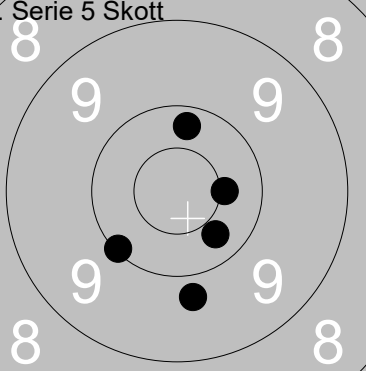
<p>2. Serie 5 Skott</p> 	<p>1: 8.8 ↗ 2: 10.5x ↗ 3: 10.2 ↑ 4: 10.7x ← 5: 10.3 ↓</p>	<p>3. Serie 5 Skott</p> 	<p>1: 10.2 ↑ 2: 9.8 ↓ 3: 10.3 ↓ 4: 10.1 ↓ 5: 10.4x →</p>
Serie 48	Total 94	Serie 49	Total 143

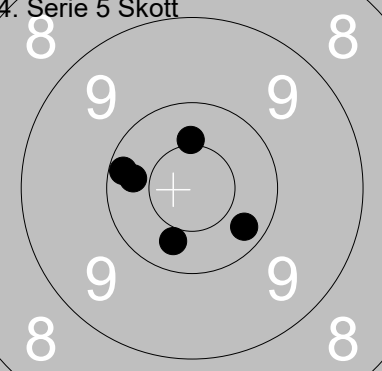
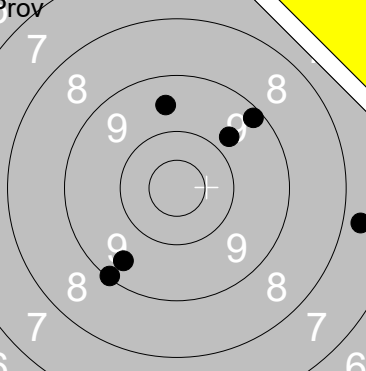

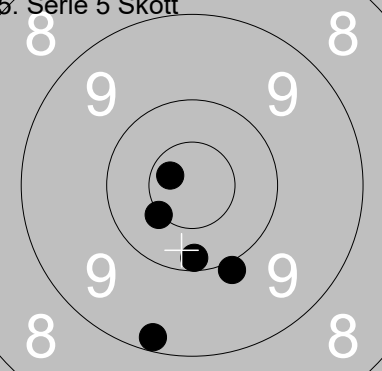
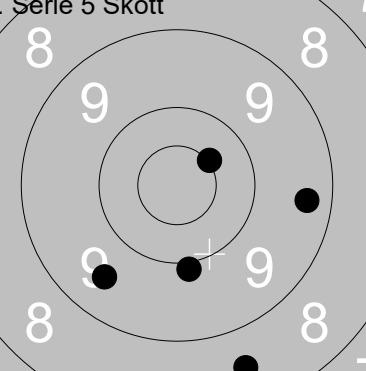
<p>4. Serie 5 Skott</p> 	<p>1: 10.3 ← 2: 10.2 ← 3: 10.4x ↑ 4: 10.2 → 5: 10.3 ↓</p>	<p>Prov</p> 	<p>1: 9.5 ↑ 2: 9.4 ↓ 3: 9.1 ↓ 4: 9.7 ↗ 5: 9.2 ↗ 6: 7.7 →</p>
Serie 50	Total 193	Serie 52	Total 193

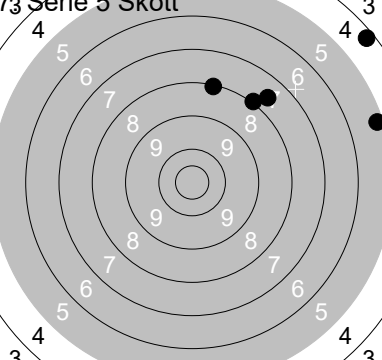
<p>5. Serie 5 Skott</p> 	<p>1: 10.7x ← 2: 10.2 ↓ 3: 10.5x ← 4: 9.9 ↓ 5: 9.2 ↓</p>	<p>6. Serie 5 Skott</p> 	<p>1: 10.5x ↗ 2: 9.5 ↓ 3: 9.4 → 4: 9.9 ↓ 5: 8.5 ↓</p>
Serie 48	Total 241	Serie 45	Total 286

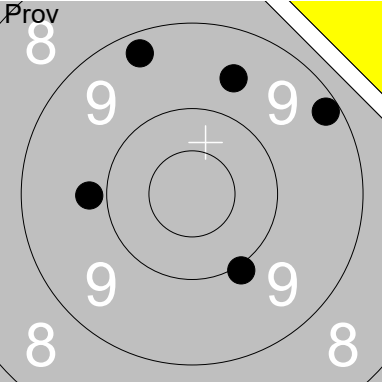
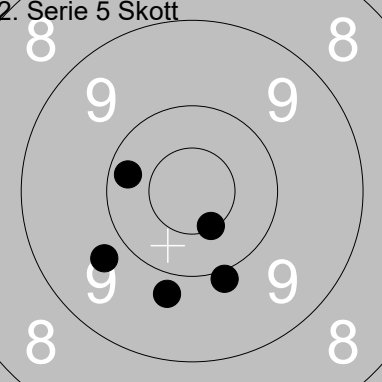
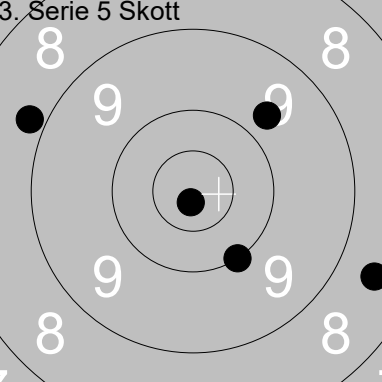
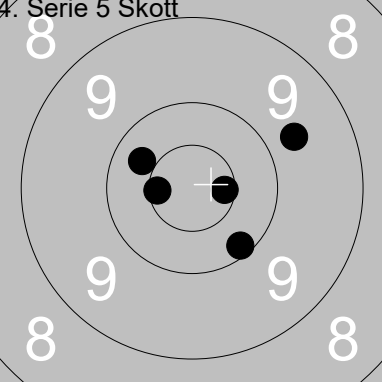
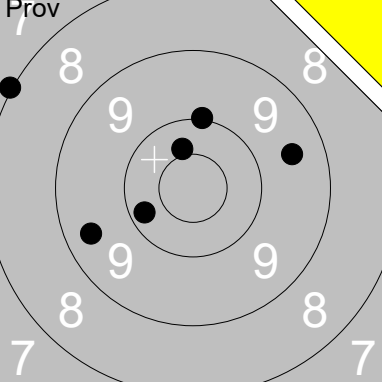
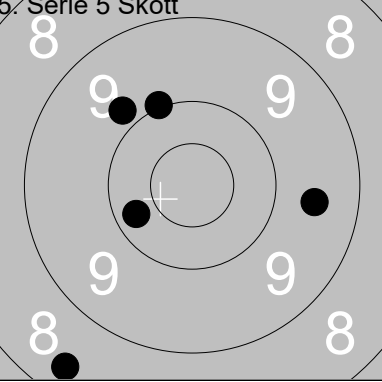
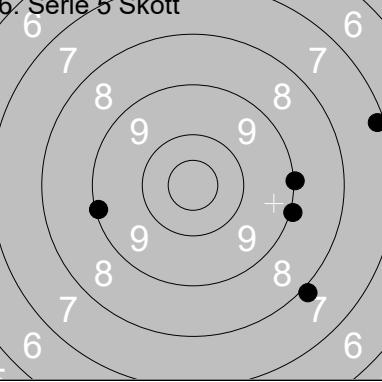
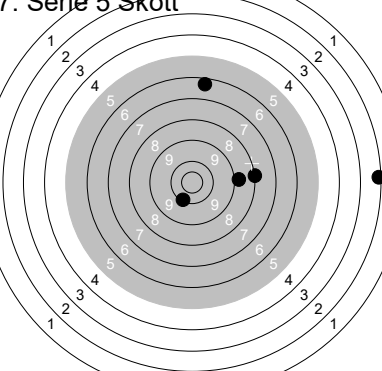
<p>7. Serie 5 Skott</p> 	<p>1: 7.6 ↗ 2: 4.2 ↗ 3: 8.1 ↑ 4: 5.2 → 5: 8.0 ↗</p>		
Serie 32	Total 318		

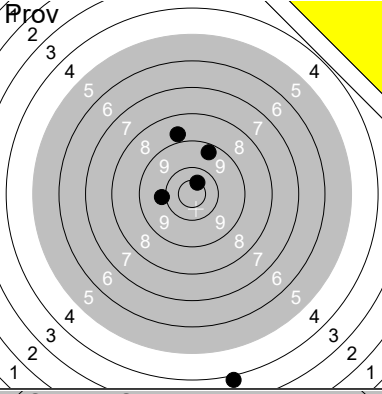
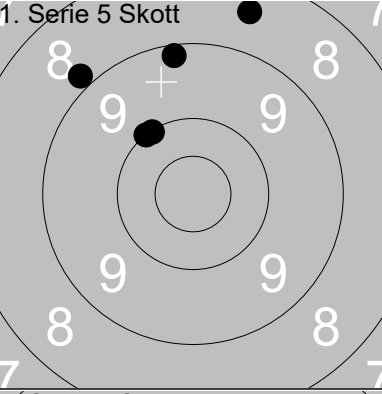
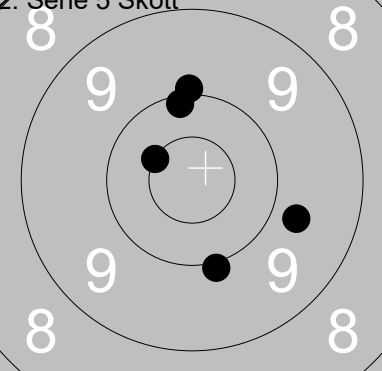
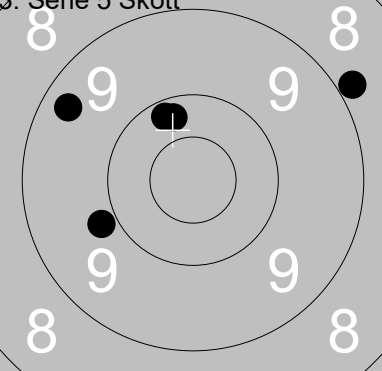
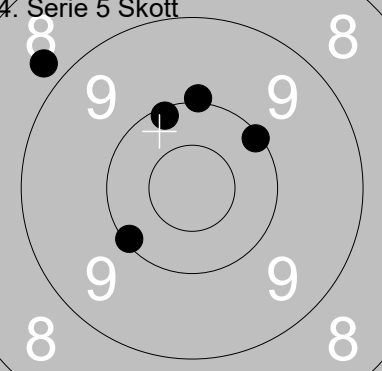
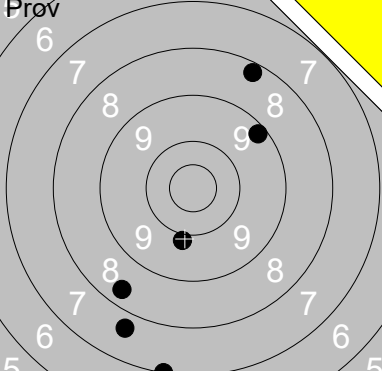
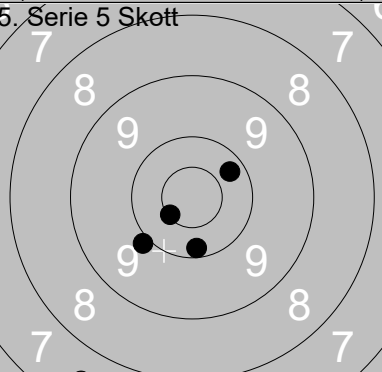
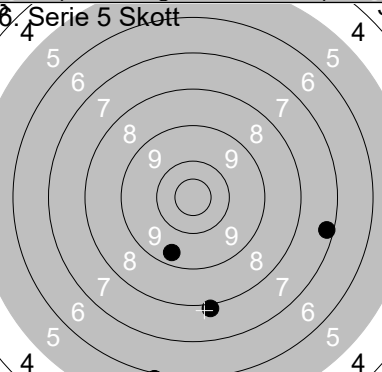
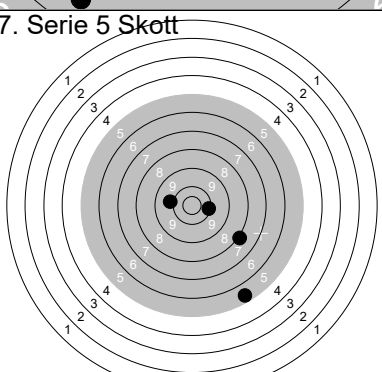
Skjutlag	Tavla	Hanna Johansson		
4	12	Ramselefors	Umeå	B Vb
07.07.2019	Tavelträffen 2019	Ramselefors SKF		
	1: 9.8 ← 2: 9.3 ↑ 3: 9.6 ↑ 4: 9.2 → 5: 10.0 ↓		1: 9.6 ↑ 2: 8.9 ↓ 3: 8.8 ↓ 4: 10.5x ↑ 5: 10.1 ↓	
	Serie 46 Total 0		Serie 45 Total 45	
	1: 10.5x ↓ 2: 9.9 ↓ 3: 9.7 ← 4: 10.2 ← 5: 9.8 ↓		1: 9.7 ↗ 2: 8.5 → 3: 10.0 ↓ 4: 8.8 ↖ 5: 10.8x ↓	
	Serie 47 Total 92		Serie 45 Total 137	
	1: 10.6x ← 2: 10.3 ↖ 3: 10.1 ↓ 4: 10.6x → 5: 9.7 →		1: 9.5 → 2: 10.0 ↑ 3: 10.2 ← 4: 10.4 ↑ 5: 8.0 ↖ 6: 9.4 ←	
	Serie 49 Total 186		Serie 56 Total 186	
	1: 10.0 ↑ 2: 9.8 ↑ 3: 10.3 ← 4: 8.4 ↓ 5: 9.6 →		1: 7.2 → 2: 9.0 → 3: 7.9 ↓ 4: 9.0 → 5: 9.1 ←	
	Serie 46 Total 232		Serie 41 Total 273	
	1: 10.1 ↓ 2: 6.3 ↑ 3: 8.0 → 4: 2.2 → 5: 8.8 →			
	Serie 34 Total 307			

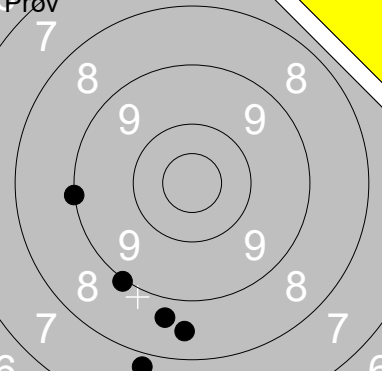
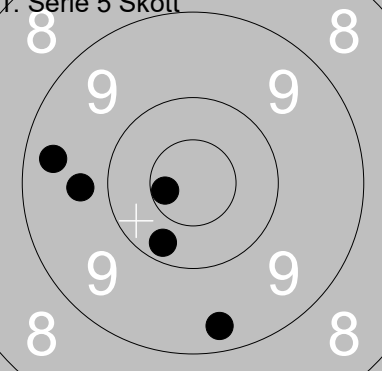
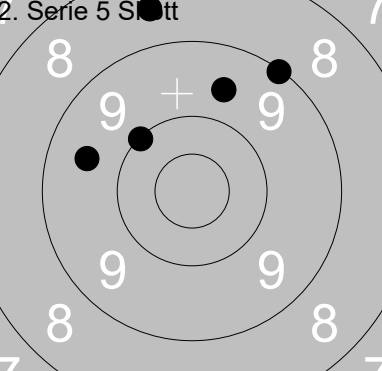
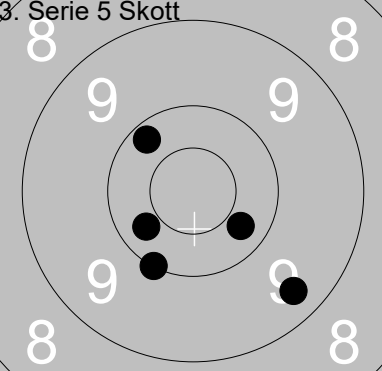
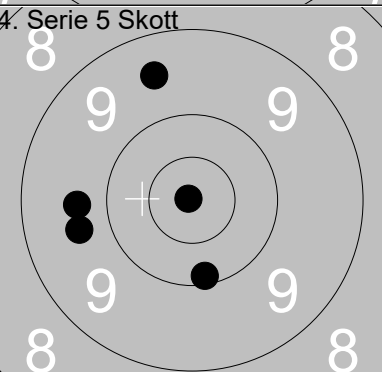
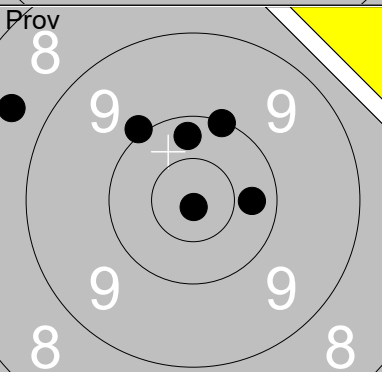
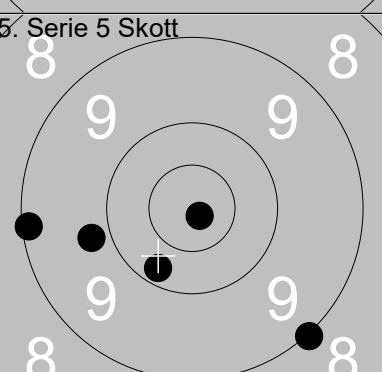
Skjutlag 4	Tavla 13	André Engström					
Ramselefors		Piteå		B	No		
07.07.2019		Tavelträffen 2019		Ramselefors SKF			
	1: 3.9 ↓ 2: 9.3 ↑ 3: 10.5x ↑ 4: 9.9 ← 5: 8.7 ↑		1: 10.0 ↖ 2: 8.5 ↑ 3: 10.0 ↖ 4: 8.9 ↖ 5: 9.2 ↑	Serie	39	Serie	45
	Total	0		Total	7	Total	45
	1: 9.7 → 2: 10.5x ↖ 3: 10.1 ↑ 4: 10.0 ↓ 5: 10.0 ↑		1: 9.3 ↖ 2: 10.2 ↑ 3: 10.2 ↑ 4: 9.8 ← 5: 8.9 ↗	Serie	49	Serie	46
	Total	94		Total	140	Total	140
	1: 10.1 ↑ 2: 10.1 ↖ 3: 10.0 ↑ 4: 10.1 ↗ 5: 8.8 ↖		1: 8.4 ↓ 2: 9.9 ↓ 3: 7.0 ↓ 4: 9.2 ↗ 5: 8.2 ↑ 6: 7.7 ↓	Serie	48	Serie	48
	Total	188		Total	188	Total	188
	1: 9.9 ↖ 2: 7.5 ↓ 3: 10.3 ↗ 4: 10.5x ↖ 5: 10.2 ↓		1: 9.4 ↓ 2: 5.9 ↓ 3: 7.9 ↓ 4: 7.2 → 5: 5.8 ↓	Serie	46	Serie	33
	Total	234		Total	267	Total	267
	1: 0.0 → 2: 7.9 ↓ 3: 9.8 ← 4: 5.4 ↓ 5: 10.1 →			Serie	31		
	Total	298		Total	298		

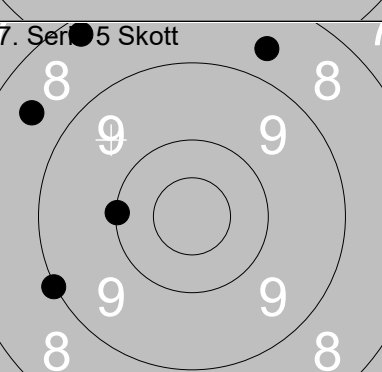
 <p>1. Serie 5 Skott</p>	<table style="width:100%; border-collapse: collapse;"> <tr><td style="padding: 2px;">1: 8.5</td><td style="padding: 2px;">↓</td></tr> <tr><td style="padding: 2px;">2: 9.0</td><td style="padding: 2px;">↓</td></tr> <tr><td style="padding: 2px;">3: 7.8</td><td style="padding: 2px;">↓</td></tr> <tr><td style="padding: 2px;">4: 8.7</td><td style="padding: 2px;">↓</td></tr> <tr><td style="padding: 2px;">5: 9.0</td><td style="padding: 2px;">←</td></tr> <tr style="border-top: 1px solid black;"><td style="padding: 2px;">Serie</td><td style="padding: 2px; text-align: right;">41</td></tr> <tr><td style="padding: 2px;">Total</td><td style="padding: 2px; text-align: right;">0</td></tr> </table>	1: 8.5	↓	2: 9.0	↓	3: 7.8	↓	4: 8.7	↓	5: 9.0	←	Serie	41	Total	0	 <p>1. Serie 5 Skott</p> <table style="width:100%; border-collapse: collapse;"> <tr><td style="padding: 2px;">1: 9.7</td><td style="padding: 2px;">←</td></tr> <tr><td style="padding: 2px;">2: 10.2</td><td style="padding: 2px;">↓</td></tr> <tr><td style="padding: 2px;">3: 9.3</td><td style="padding: 2px;">↓</td></tr> <tr><td style="padding: 2px;">4: 10.6x</td><td style="padding: 2px;">←</td></tr> <tr><td style="padding: 2px;">5: 9.4</td><td style="padding: 2px;">←</td></tr> <tr style="border-top: 1px solid black;"><td style="padding: 2px;">Serie</td><td style="padding: 2px; text-align: right;">47</td></tr> <tr><td style="padding: 2px;">Total</td><td style="padding: 2px; text-align: right;">47</td></tr> </table>	1: 9.7	←	2: 10.2	↓	3: 9.3	↓	4: 10.6x	←	5: 9.4	←	Serie	47	Total	47		
1: 8.5	↓																															
2: 9.0	↓																															
3: 7.8	↓																															
4: 8.7	↓																															
5: 9.0	←																															
Serie	41																															
Total	0																															
1: 9.7	←																															
2: 10.2	↓																															
3: 9.3	↓																															
4: 10.6x	←																															
5: 9.4	←																															
Serie	47																															
Total	47																															
 <p>2. Serie 5 Skott</p>	<table style="width:100%; border-collapse: collapse;"> <tr><td style="padding: 2px;">1: 8.5</td><td style="padding: 2px;">↑</td></tr> <tr><td style="padding: 2px;">2: 10.0</td><td style="padding: 2px;">↗</td></tr> <tr><td style="padding: 2px;">3: 9.1</td><td style="padding: 2px;">↗</td></tr> <tr><td style="padding: 2px;">4: 9.6</td><td style="padding: 2px;">↑</td></tr> <tr><td style="padding: 2px;">5: 9.6</td><td style="padding: 2px;">←</td></tr> <tr style="border-top: 1px solid black;"><td style="padding: 2px;">Serie</td><td style="padding: 2px; text-align: right;">45</td></tr> <tr><td style="padding: 2px;">Total</td><td style="padding: 2px; text-align: right;">92</td></tr> </table>	1: 8.5	↑	2: 10.0	↗	3: 9.1	↗	4: 9.6	↑	5: 9.6	←	Serie	45	Total	92	 <p>3. Serie 5 Skott</p> <table style="width:100%; border-collapse: collapse;"> <tr><td style="padding: 2px;">1: 10.3</td><td style="padding: 2px;">↖</td></tr> <tr><td style="padding: 2px;">2: 9.4</td><td style="padding: 2px;">↘</td></tr> <tr><td style="padding: 2px;">3: 10.2</td><td style="padding: 2px;">↗</td></tr> <tr><td style="padding: 2px;">4: 10.0</td><td style="padding: 2px;">↓</td></tr> <tr><td style="padding: 2px;">5: 10.3</td><td style="padding: 2px;">↘</td></tr> <tr style="border-top: 1px solid black;"><td style="padding: 2px;">Serie</td><td style="padding: 2px; text-align: right;">49</td></tr> <tr><td style="padding: 2px;">Total</td><td style="padding: 2px; text-align: right;">141</td></tr> </table>	1: 10.3	↖	2: 9.4	↘	3: 10.2	↗	4: 10.0	↓	5: 10.3	↘	Serie	49	Total	141		
1: 8.5	↑																															
2: 10.0	↗																															
3: 9.1	↗																															
4: 9.6	↑																															
5: 9.6	←																															
Serie	45																															
Total	92																															
1: 10.3	↖																															
2: 9.4	↘																															
3: 10.2	↗																															
4: 10.0	↓																															
5: 10.3	↘																															
Serie	49																															
Total	141																															
 <p>4. Serie 5 Skott</p>	<table style="width:100%; border-collapse: collapse;"> <tr><td style="padding: 2px;">1: 9.7</td><td style="padding: 2px;">←</td></tr> <tr><td style="padding: 2px;">2: 10.9x</td><td style="padding: 2px;">←</td></tr> <tr><td style="padding: 2px;">3: 9.5</td><td style="padding: 2px;">↑</td></tr> <tr><td style="padding: 2px;">4: 10.1</td><td style="padding: 2px;">↓</td></tr> <tr><td style="padding: 2px;">5: 9.7</td><td style="padding: 2px;">←</td></tr> <tr style="border-top: 1px solid black;"><td style="padding: 2px;">Serie</td><td style="padding: 2px; text-align: right;">47</td></tr> <tr><td style="padding: 2px;">Total</td><td style="padding: 2px; text-align: right;">188</td></tr> </table>	1: 9.7	←	2: 10.9x	←	3: 9.5	↑	4: 10.1	↓	5: 9.7	←	Serie	47	Total	188	 <p>4. Serie 5 Skott</p> <table style="width:100%; border-collapse: collapse;"> <tr><td style="padding: 2px;">1: 10.0</td><td style="padding: 2px;">↑</td></tr> <tr><td style="padding: 2px;">2: 10.0</td><td style="padding: 2px;">↗</td></tr> <tr><td style="padding: 2px;">3: 10.3</td><td style="padding: 2px;">→</td></tr> <tr><td style="padding: 2px;">4: 10.9x</td><td style="padding: 2px;">↓</td></tr> <tr><td style="padding: 2px;">5: 8.6</td><td style="padding: 2px;">↖</td></tr> <tr><td style="padding: 2px;">6: 10.2</td><td style="padding: 2px;">↑</td></tr> <tr style="border-top: 1px solid black;"><td style="padding: 2px;">Serie</td><td style="padding: 2px; text-align: right;">58</td></tr> <tr><td style="padding: 2px;">Total</td><td style="padding: 2px; text-align: right;">188</td></tr> </table>	1: 10.0	↑	2: 10.0	↗	3: 10.3	→	4: 10.9x	↓	5: 8.6	↖	6: 10.2	↑	Serie	58	Total	188
1: 9.7	←																															
2: 10.9x	←																															
3: 9.5	↑																															
4: 10.1	↓																															
5: 9.7	←																															
Serie	47																															
Total	188																															
1: 10.0	↑																															
2: 10.0	↗																															
3: 10.3	→																															
4: 10.9x	↓																															
5: 8.6	↖																															
6: 10.2	↑																															
Serie	58																															
Total	188																															
 <p>5. Serie 5 Skott</p>	<table style="width:100%; border-collapse: collapse;"> <tr><td style="padding: 2px;">1: 9.1</td><td style="padding: 2px;">←</td></tr> <tr><td style="padding: 2px;">2: 9.8</td><td style="padding: 2px;">←</td></tr> <tr><td style="padding: 2px;">3: 9.0</td><td style="padding: 2px;">↓</td></tr> <tr><td style="padding: 2px;">4: 10.8x</td><td style="padding: 2px;">↓</td></tr> <tr><td style="padding: 2px;">5: 10.2</td><td style="padding: 2px;">↓</td></tr> <tr style="border-top: 1px solid black;"><td style="padding: 2px;">Serie</td><td style="padding: 2px; text-align: right;">47</td></tr> <tr><td style="padding: 2px;">Total</td><td style="padding: 2px; text-align: right;">235</td></tr> </table>	1: 9.1	←	2: 9.8	←	3: 9.0	↓	4: 10.8x	↓	5: 10.2	↓	Serie	47	Total	235	 <p>6. Serie 5 Skott</p> <table style="width:100%; border-collapse: collapse;"> <tr><td style="padding: 2px;">1: 9.9</td><td style="padding: 2px;">↖</td></tr> <tr><td style="padding: 2px;">2: 10.2</td><td style="padding: 2px;">↘</td></tr> <tr><td style="padding: 2px;">3: 10.3</td><td style="padding: 2px;">↗</td></tr> <tr><td style="padding: 2px;">4: 9.5</td><td style="padding: 2px;">↓</td></tr> <tr><td style="padding: 2px;">5: 9.6</td><td style="padding: 2px;">→</td></tr> <tr style="border-top: 1px solid black;"><td style="padding: 2px;">Serie</td><td style="padding: 2px; text-align: right;">47</td></tr> <tr><td style="padding: 2px;">Total</td><td style="padding: 2px; text-align: right;">282</td></tr> </table>	1: 9.9	↖	2: 10.2	↘	3: 10.3	↗	4: 9.5	↓	5: 9.6	→	Serie	47	Total	282		
1: 9.1	←																															
2: 9.8	←																															
3: 9.0	↓																															
4: 10.8x	↓																															
5: 10.2	↓																															
Serie	47																															
Total	235																															
1: 9.9	↖																															
2: 10.2	↘																															
3: 10.3	↗																															
4: 9.5	↓																															
5: 9.6	→																															
Serie	47																															
Total	282																															
 <p>7. Serie 5 Skott</p>	<table style="width:100%; border-collapse: collapse;"> <tr><td style="padding: 2px;">1: 8.6</td><td style="padding: 2px;">↑</td></tr> <tr><td style="padding: 2px;">2: 8.5</td><td style="padding: 2px;">↖</td></tr> <tr><td style="padding: 2px;">3: 8.2</td><td style="padding: 2px;">↖</td></tr> <tr><td style="padding: 2px;">4: 10.0</td><td style="padding: 2px;">←</td></tr> <tr><td style="padding: 2px;">5: 9.0</td><td style="padding: 2px;">←</td></tr> <tr style="border-top: 1px solid black;"><td style="padding: 2px;">Serie</td><td style="padding: 2px; text-align: right;">43</td></tr> <tr><td style="padding: 2px;">Total</td><td style="padding: 2px; text-align: right;">325</td></tr> </table>	1: 8.6	↑	2: 8.5	↖	3: 8.2	↖	4: 10.0	←	5: 9.0	←	Serie	43	Total	325																	
1: 8.6	↑																															
2: 8.5	↖																															
3: 8.2	↖																															
4: 10.0	←																															
5: 9.0	←																															
Serie	43																															
Total	325																															

Skjutlag 4	Tavla 16	Anna Eklöf	
Ramselefors	Storfors	A	Vä
07.07.2019	Tavelträffen 2019	Ramselefors SKF	
Prov 	1: 9.5 ↗ 2: 9.9 ↑ 3: 9.4 ↗ 4: 10.5x ↗ 5: 9.9 →	1. Serie 5 Skott 	1: 10.4 ↓ 2: 10.5x ← 3: 10.4x ← 4: 10.3 ↓ 5: 9.9 ↖
Serie 46	Total 0	Serie 49	Total 49
2. Serie 5 Skott 	1: 10.1 ↙ 2: 10.6x ↓ 3: 9.1 ↙ 4: 9.4 ↙ 5: 9.7 ↓	3. Serie 5 Skott 	1: 10.0 ↓ 2: 10.1 ↓ 3: 10.6x ↑ 4: 10.4 ↗ 5: 10.4 ←
Serie 47	Total 96	Serie 50	Total 146
4. Serie 5 Skott 	1: 10.0 ⇒ 2: 9.9 ↑ 3: 10.7x ← 4: 10.8x ↑ 5: 10.6x ←	Prov 	1: 9.9 → 2: 9.7 ↓ 3: 9.5 ← 4: 9.9 ↗ 5: 9.1 ← 6: 9.9 ←
Serie 49	Total 195	Serie 54	Total 195
5. Serie 5 Skott 	1: 10.4x ⇒ 2: 10.1 ↑ 3: 10.3 ↑ 4: 10.2 ↖ 5: 9.9 ↓	6. Serie 5 Skott 	1: 10.2 ↓ 2: 9.7 ← 3: 10.4 ↓ 4: 9.9 ↗ 5: 9.7 →
Serie 49	Total 244	Serie 47	Total 291
7. Serie 5 Skott 	1: 10.4x ↑ 2: 8.4 ↓ 3: 10.3 → 4: 7.9 ↖ 5: 8.9 →		
Serie 43	Total 334		

Skjutlag	Tavla	Björn Johansson	
4	17	Ramselefors	Kvistbro
07.07.2019	Tavelträffen 2019	Ramselefors SKF	
	1: 9.5 ↗ 2: 10.4x ↑ 3: 10.1 ↗ 4: 9.4 ↓ 5: 10.3 ↓	1. Serie 5 Skott 	1: 9.7 ↓ 2: 10.3 ↓ 3: 10.6x ← 4: 9.6 ↓ 5: 9.7 ←
Serie 48	Total 0	Serie 47	Total 47
2. Serie 5 Skott 	1: 10.1 ↓ 2: 9.9 ↓ 3: 9.4 ↓ 4: 10.2 ↗ 5: 10.4x ↓	3. Serie 5 Skott 	1: 10.1 ↗ 2: 9.4 ↑ 3: 9.6 ↑ 4: 10.6x ↑ 5: 9.8 ↓
Serie 48	Total 95	Serie 47	Total 142
4. Serie 5 Skott 	1: 10.6x → 2: 10.9x → 3: 9.6 ↗ 4: 10.4x → 5: 9.6 ←	Prov 	1: 9.5 ↑ 2: 9.8 → 3: 10.3 → 4: 10.6x → 5: 10.7x ← 6: 9.8 ↗
Serie 48	Total 190	Serie 57	Total 190
5. Serie 5 Skott 	1: 9.9 ← 2: 10.6x → 3: 10.4 ↗ 4: 9.0 ↓ 5: 10.5x ↓	6. Serie 5 Skott 	1: 8.7 ← 2: 10.0 ↓ 3: 10.5x ← 4: 9.9 ↑ 5: 9.1 ↓
Serie 48	Total 238	Serie 46	Total 284
7. Serie 5 Skott 	1: 6.3 ↑ 2: 8.8 ↗ 3: 9.8 ↗ 4: 9.9 ↓ 5: 10.2 ←		
Serie 42	Total 326		

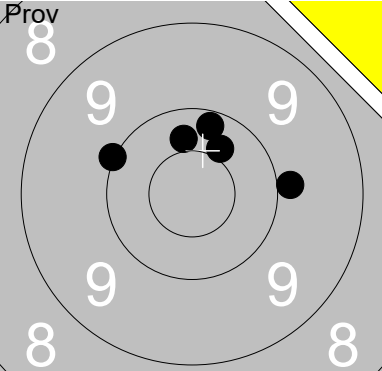
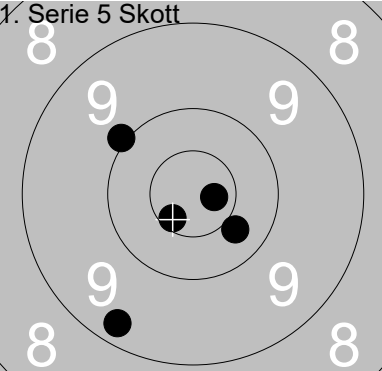
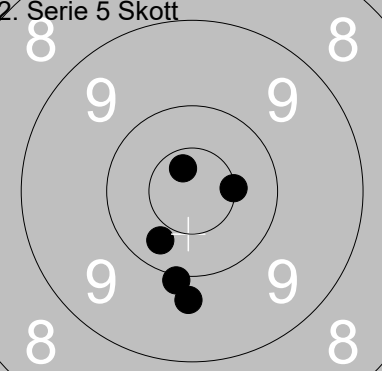
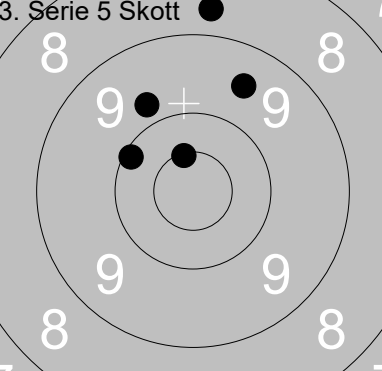
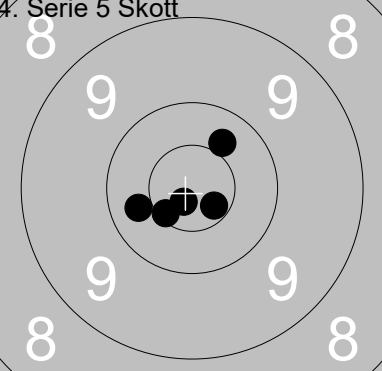
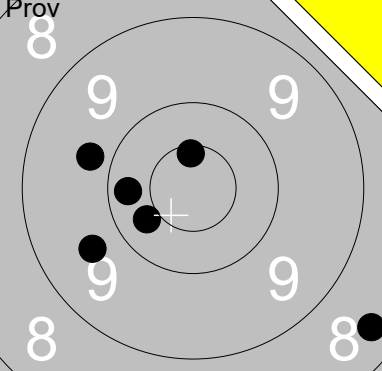
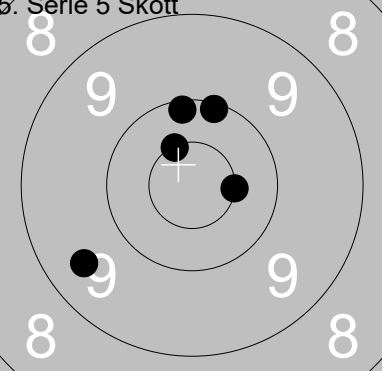
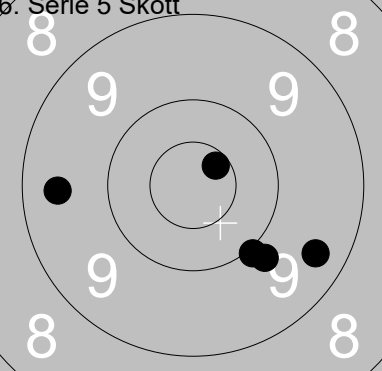
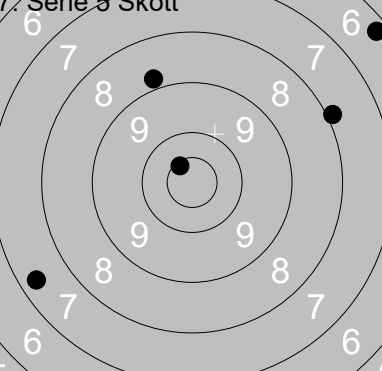
Skjutlag	Tavla	Urban Johansson	
4	18		
Ramselefors	F 21	A	No
07.07.2019	Tavelträffen 2019	Ramselefors SKF	
	1: 10.3 ↑ 2: 10.0 ↖ 3: 9.9 → 4: 10.2 ↑ 5: 10.4 ↗	1. Serie 5 Skott 	1: 10.0 ↖ 2: 10.7x → 3: 10.6x ↙ 4: 10.4 ↘ 5: 9.3 ↙
Serie 49	Total 0	Serie 49	Total 49
	1: 10.0 ↓ 2: 10.3 ↙ 3: 9.8 ↘ 4: 10.7x ↗ 5: 10.5x →	3. Serie 5 Skott 	1: 10.5x ↑ 2: 10.1 ↖ 3: 9.8 ↗ 4: 8.7 ↑ 5: 9.5 ↗
Serie 49	Total 98	Serie 46	Total 144
	1: 10.3 ↖ 2: 10.8x ↙ 3: 10.4 ↗ 4: 10.6x ↘ 5: 10.6x ↙	Prov 	1: 10.6x ↑ 2: 10.4 ↖ 3: 9.8 ↖ 4: 10.2 ↖ 5: 8.4 ↘ 6: 9.7 ↖
Serie 50	Total 194	Serie 56	Total 194
	1: 10.5x ↗ 2: 10.1 ↑ 3: 9.5 ↖ 4: 10.1 ↑ 5: 10.5x →	6. Serie 5 Skott 	1: 9.4 ↖ 2: 10.6x ↗ 3: 9.4 ↘ 4: 10.0 ↘ 5: 9.8 ↘
Serie 49	Total 243	Serie 47	Total 290
	1: 7.9 → 2: 8.8 ↗ 3: 6.3 ↗ 4: 7.4 ↖ 5: 10.6x ↖		
Serie 38	Total 328		

Skjutlag	Tavla	Caroline Törnvall	
4	19	Ramselefors	Ultuna
07.07.2019	Tavelträffen 2019	Ramselefors SKF	
	1: 9.7 ↗ 2: 9.9 ← 3: 10.1 ↑ 4: 9.4 → 5: 10.0 ↓	1. Serie 5 Skott	1: 10.4 ← 2: 10.0 ↖ 3: 9.9 ↓ 4: 10.8x ↑ 5: 10.1 →
Serie	47	Serie	49
Total	0	Total	49
	1: 10.0 → 2: 10.1 ↗ 3: 9.9 ↘ 4: 10.0 ↓ 5: 10.5x ↙	3. Serie 5 Skott	1: 9.7 ← 2: 10.0 → 3: 10.4 ↗ 4: 10.4 ↗ 5: 10.1 ↓
Serie	49	Serie	49
Total	98	Total	147
	1: 9.4 ↑ 2: 10.5x ↑ 3: 9.8 ↓ 4: 10.6x → 5: 10.7x ←		1: 10.3 ↗ 2: 10.1 ↓ 3: 8.8 ↓ 4: 10.4 ↖ 5: 10.2 ↗ 6: 8.8 ↖
Serie	48	Serie	56
Total	195	Total	195
	1: 9.7 ↙ 2: 10.1 ↓ 3: 10.4 → 4: 10.1 ↗ 5: 10.8x →	6. Serie 5 Skott	1: 9.6 ← 2: 9.5 ← 3: 10.1 ↑ 4: 9.4 ↙ 5: 8.9 ↓
Serie	49	Serie	45
Total	244	Total	289
	1: 9.8 ↑ 2: 7.4 ← 3: 9.7 ↓ 4: 10.3 ↖ 5: 8.7 ↙		
Serie	43		
Total	332		

Skjutlag	Tavla	Leif Sandberg	
4	21	Ramselefors	Kalix
07.07.2019		Tavelträffen 2019	Ramselefors SKF
	1: 9.5 ↘ 2: 9.5 ← 3: 9.7 ↑ 4: 9.7 → 5: 10.0 ↓		1: 9.5 ← 2: 10.1 ← 3: 9.2 ↓ 4: 10.5x ↓ 5: 9.0 ←
	Serie 46		Serie 47
	Total 0		Total 47
	1: 10.3 ↓ 2: 10.7x → 3: 10.8x → 4: 10.5x ← 5: 10.3 ↓		1: 10.8x ← 2: 10.5x ↑ 3: 10.3 ↗ 4: 10.3 ↑ 5: 10.2 ↖
	Serie 50		Serie 50
	Total 97		Total 147
	1: 10.1 ↑ 2: 10.5x → 3: 9.3 ← 4: 10.2 → 5: 10.7x ↓		1: 9.8 → 2: 10.3 ↑ 3: 9.3 ← 4: 10.3 ↑ 5: 9.6 → 6: 8.1 →
	Serie 49		Serie 55
	Total 196		Total 196
	1: 10.4 ↓ 2: 10.3 ← 3: 9.7 ↖ 4: 10.0 ← 5: 10.5x ↑		1: 9.1 ← 2: 9.7 ↓ 3: 10.1 ↓ 4: 9.6 ↗ 5: 9.0 →
	Serie 49		Serie 46
	Total 245		Total 291
	1: 9.2 → 2: 9.7 ↑ 3: 10.4 → 4: 9.2 ↓ 5: 9.3 ↗		
	Serie 46		
	Total 337		

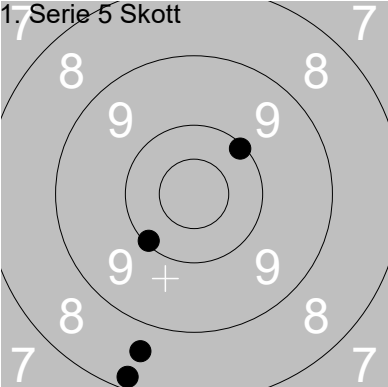
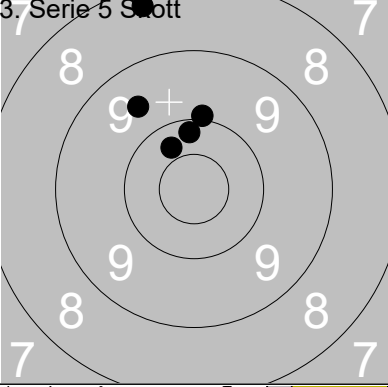
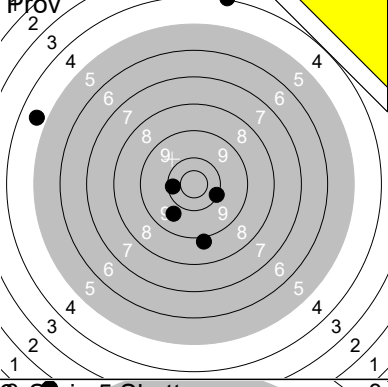
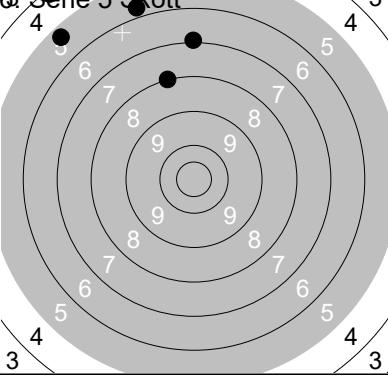
Skjutlag	Tavla	Robert Ek	
4	22		
Ramselefors	Kalix	C	No
07.07.2019	Tavelträffen 2019	Ramselefors SKF	
	1: 9.7 → 2: 8.6 ↓ 3: 10.1 → 4: 9.1 ↑ 5: 9.2 ↓	1. Serie 5 Skott 	1: 10.1 ↗ 2: 10.1 ↘ 3: 8.2 ↓ 4: 8.6 ↓
Serie 45	Total 0	Serie 36	Total 36
2. Serie 5 Skott 	1: 7.4 ↖ 2: 9.3 ↓ 3: 8.1 ← 4: 10.0 ↗ 5: 9.0 ↓	3. Serie 5 Skott 	1: 10.2 ↑ 2: 10.0 ↑ 3: 8.3 ↑ 4: 10.3 ↗ 5: 9.6 ↗
Serie 43	Total 79	Serie 47	Total 126
4. Serie 5 Skott 	1: 10.5x ↗ 2: 10.4 → 3: 10.3 ← 4: 8.5 ↑ 5: 9.5 ←	Prov 	1: 8.9 ↓ 2: 9.7 ↓ 3: 10.2 ← 4: 10.1 → 5: 4.6 ↖ 6: 4.0 ↑
Serie 47	Total 173	Serie 45	Total 173
5. Serie 5 Skott 	1: 8.2 ↖ 2: 9.4 ↖ 3: 10.0 ↓ 4: 10.7x → 5: 10.1 ↑	6. Serie 5 Skott 	1: 5.3 ↖ 2: 7.0 ↑ 3: 4.2 ↖ 4: 5.7 ↑ 5: 8.0 ↑
Serie 47	Total 220	Serie 29	Total 249
7. Serie 5 Skott 	1: 5.8 ↖ 2: 6.7 ↑ 3: 6.8 ↑ 4: 5.4 ↖ 5: 6.7 ↑		
Serie 28	Total 277		