

1:	10.2	↓
2:	10.3x	↓
3:	9.4	↑
4:	10.9x	→
5:	9.5	↗
6:	9.9	↖
7:	9.8	↖
8:	9.5	↖
9:	9.8	↗
10:	9.7	↗
Serie		93
Total		189

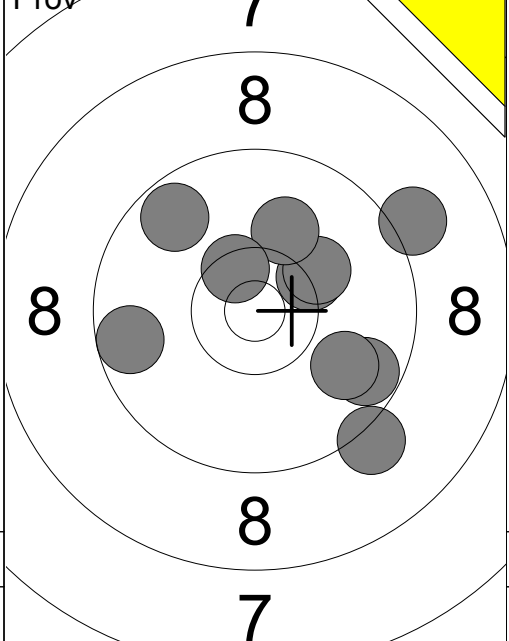

11:	10.3	↗
12:	10.2	↗
13:	9.6	←
14:	10.1	↑
15:	9.7	↘
16:	9.2	↓
17:	10.5x	↖
18:	9.7	↖
19:	9.1	↗
20:	9.9	↘
Serie		94
Total		189

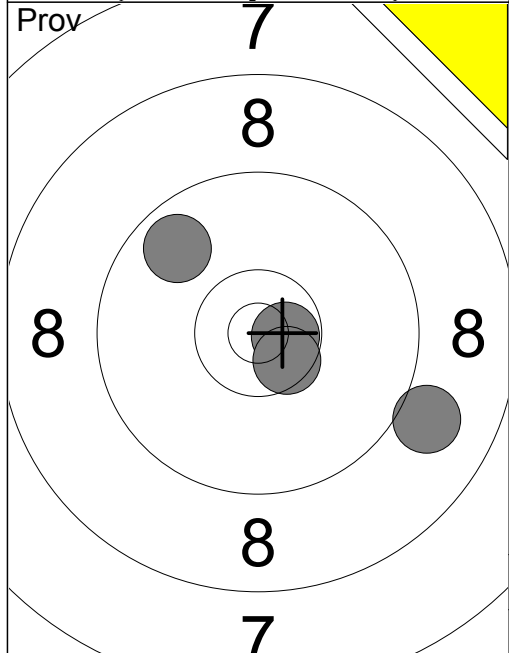

21:	9.8	↖
22:	9.0	↘
23:	10.7x	→
24:	10.5x	↘
Serie		38
Total		189

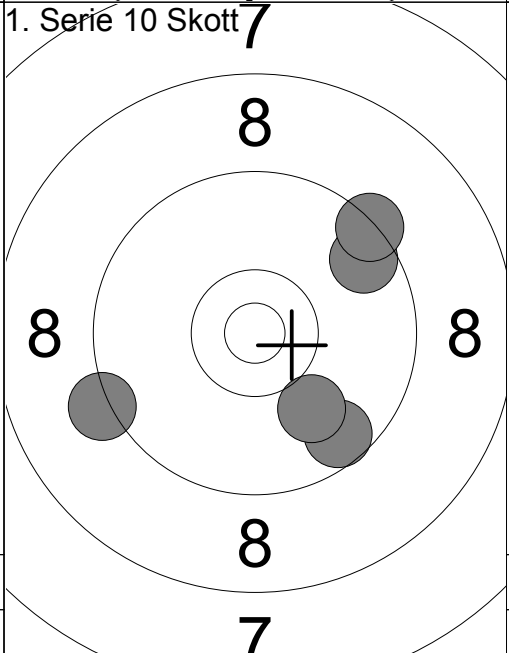

1. Serie 10 Skott 7		
1:	9.6	↘
2:	9.2	←
3:	10.0	↓
4:	9.6	↗
5:	9.4	↗
Serie		46
Total		235

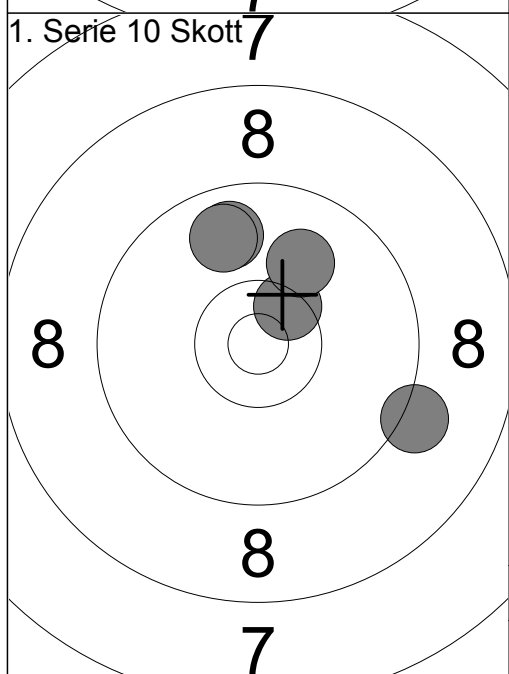

1. Serie 10 Skott 7		
6:	9.8	↖
7:	9.8	↖
8:	10.5x	↗
9:	9.2	↘
10:	10.0	↖
Serie		47
Total		282

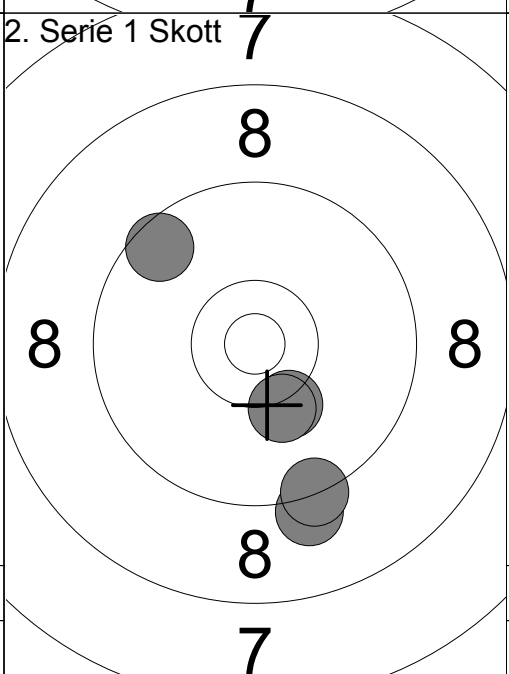

2. Serie 1 Skott 7		
1:	10.2	↓
2:	9.1	↓
3:	9.6	↖
4:	10.2	↓
5:	9.3	↘
Serie		47
Total		329

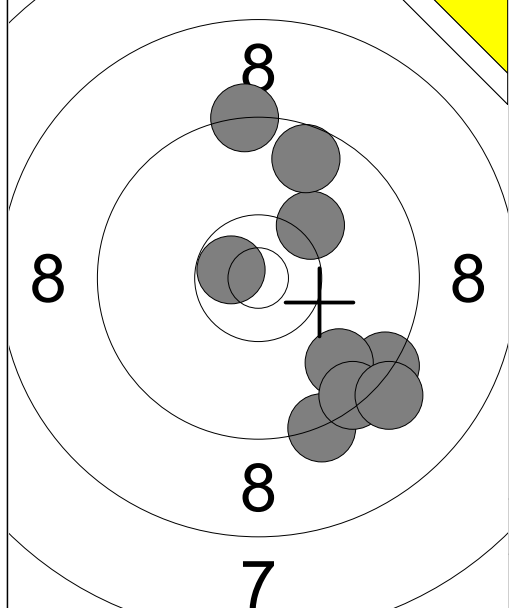

1:	9.3	↘
2:	9.5	↘
3:	10.7x	↙
4:	9.4	↘
5:	9.8	↘
6:	9.4	↘
7:	10.2	↗
8:	9.1	↘
9:	9.3	↗
10:	9.6	↗
Serie		92
Total		188

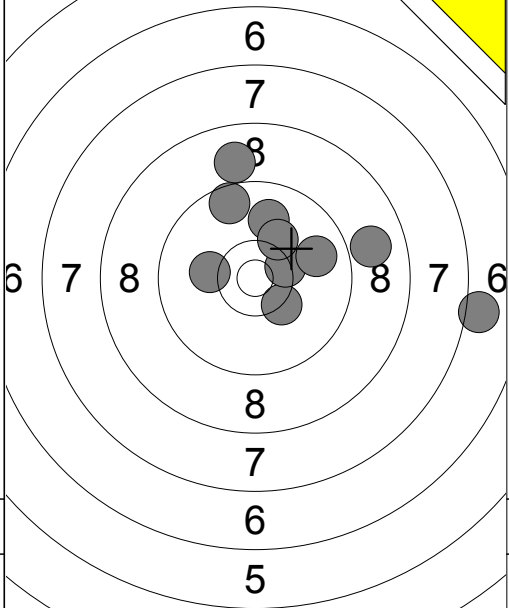

11:	7.1	→
12:	8.9	→
13:	8.9	↑
14:	10.3x	↘
15:	9.9	↑
16:	10.2	↙
17:	10.4x	↗
18:	10.2	↗
19:	9.6	↑
20:	9.8	→
Serie		90
Total		188

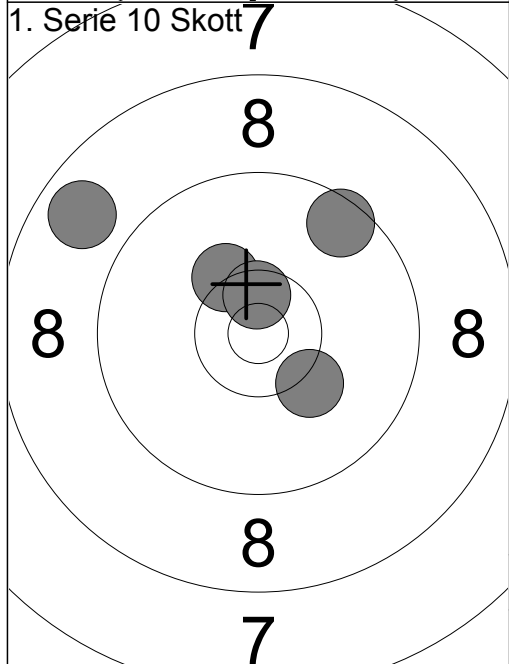

1:	9.5	↗
2:	10.3	↖
3:	10.6x	↑
4:	10.2	↘
5:	8.8	↗
Serie		47
Total		235

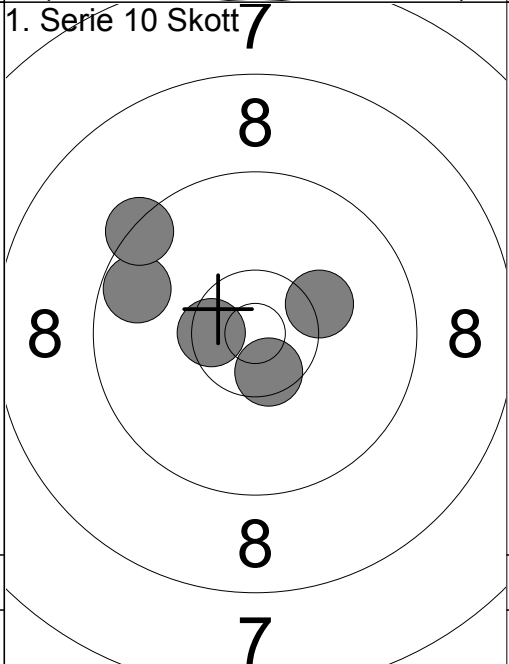

6:	10.2	↗
7:	10.5x	↙
8:	9.7	↙
9:	10.5x	↘
10:	9.4	↖
Serie		48
Total		283

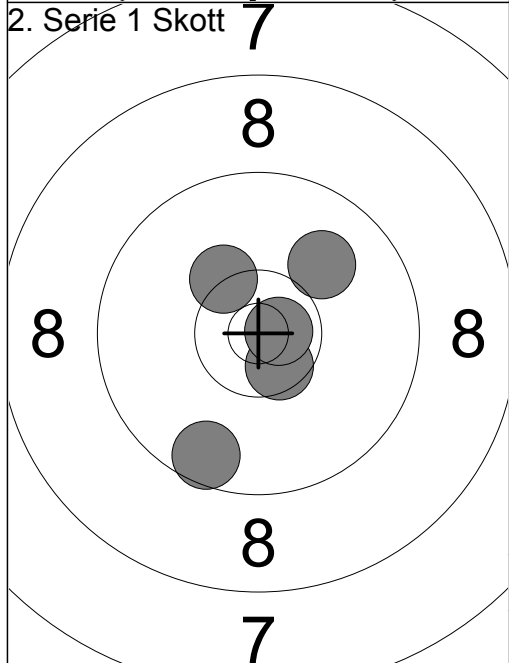

1:	9.6	↘
2:	10.0	↗
3:	10.6x	↘
4:	10.7x	→
5:	10.3	↖
Serie		49
Total		332

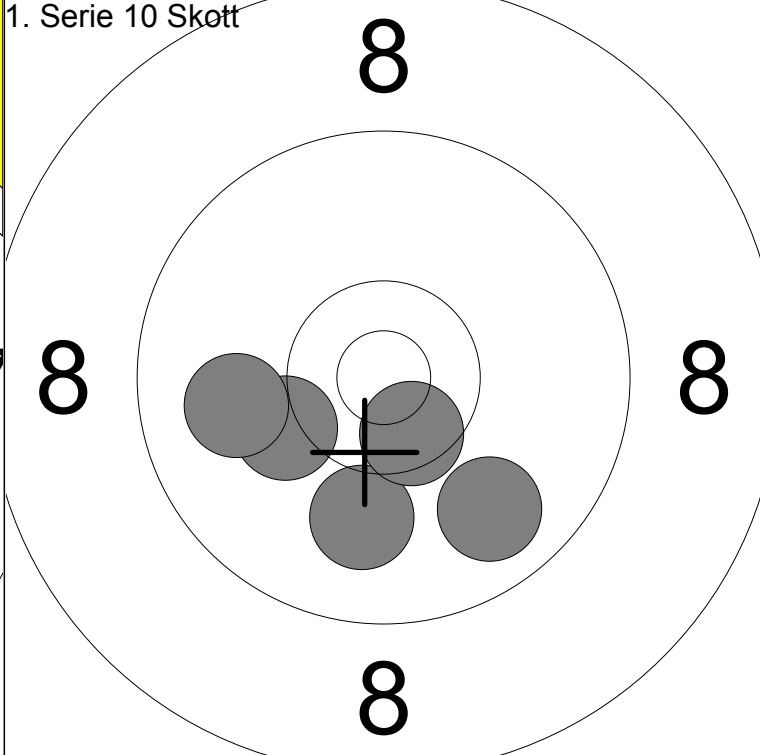
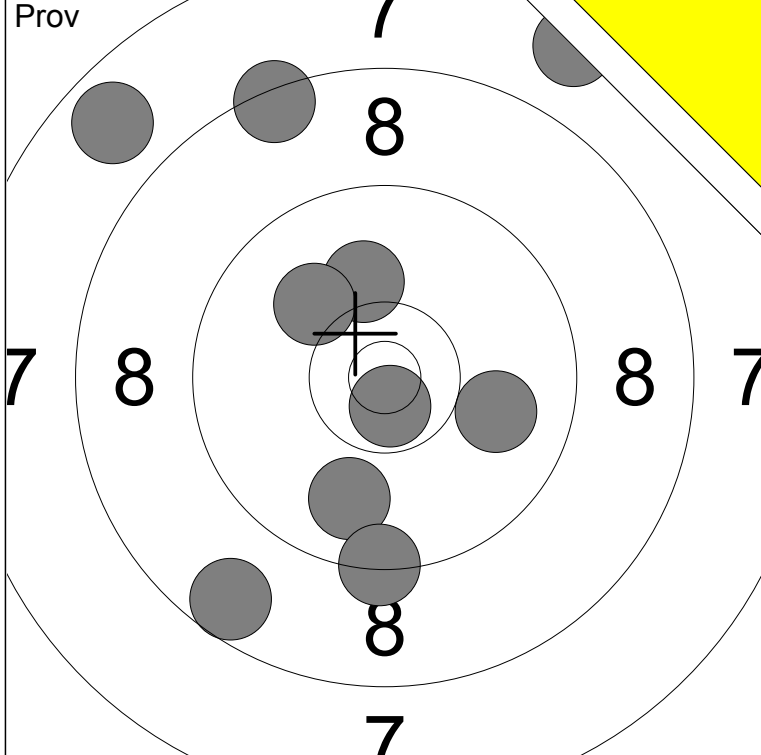

1: 7.7 ↗	6: 8.4 ↗	Serie	88
2: 10.7x ↓	7: 9.9 ↓		
3: 7.7 ↗	8: 9.3 ↓	Total	187
4: 10.1 ↑	9: 10.0 →		
5: 10.1 ↖	10: 8.6 ↘		

1: 10.0 ↓	Serie	48
2: 10.2 ←		
3: 9.8 ↓	Total	235
4: 9.9 ←		
5: 10.5x ↓		

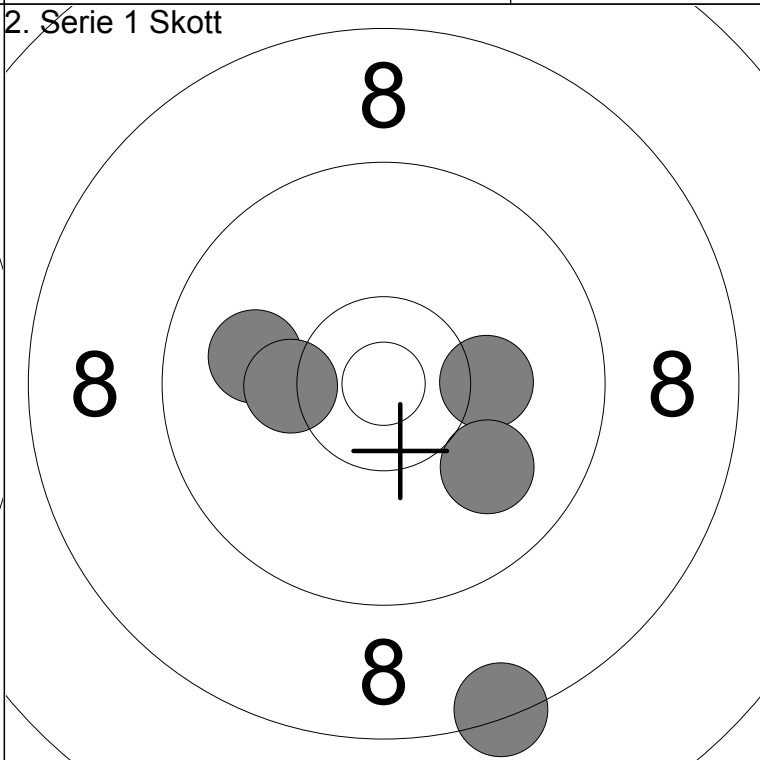
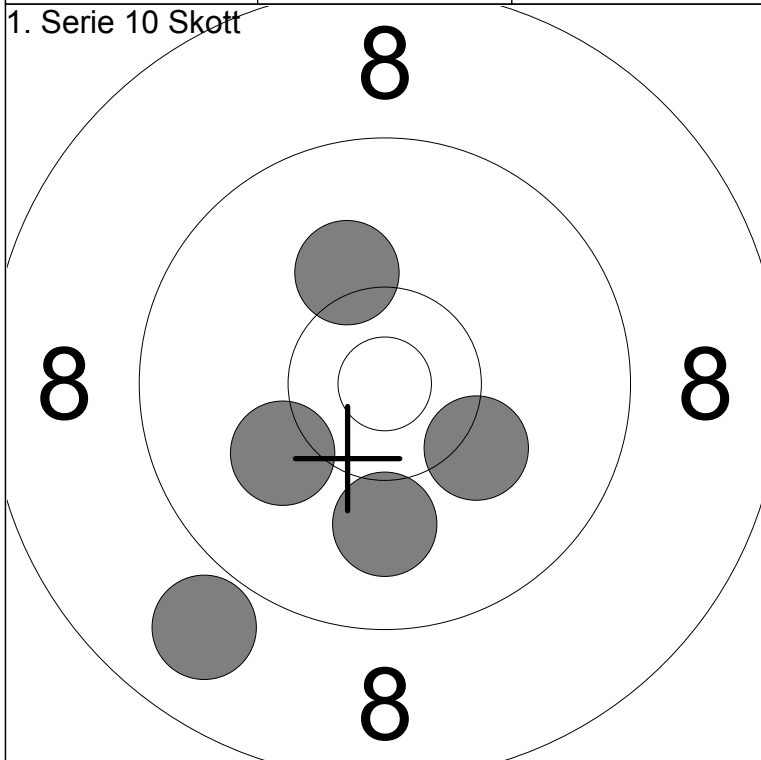

6: 10.1 ←	Serie	48
7: 10.2 ↑		
8: 10.0 ↓	Total	283
9: 10.2 ↓		
10: 8.9 ↘		

1: 10.2 →	Serie	48
2: 10.0 ←		
3: 10.3 ←	Total	331
4: 8.4 ↓		
5: 10.0 ↓		

Prov 	1: 8.5 → 2: 8.0 ↓ 3: 9.1 ↑ 4: 9.9 ↗ 5: 9.4 ↓ 6: 8.7 ↓ 7: 8.9 ↓ 8: 9.1 ↓ 9: 10.1 → 10: 10.0 ← Serie 88 Total 186	Prov 	11: 10.5x → 12: 10.1 ↑ 13: 10.0 ↗ 14: 9.2 ← 15: 9.5 ↗ 16: 9.3 → 17: 9.9 ← Serie 66 Total 186
----------	--	----------	--

1. Serie 10 Skott 7 	1: 9.6 ← 2: 10.6x → 3: 9.8 ↑ 4: 8.4 ↓ 5: 9.5 ↗ Serie 45 Total 231	1. Serie 10 Skott 7 	6: 9.9 ← 7: 10.5x ← 8: 8.8 ← 9: 9.7 ← 10: 10.7x ↓ Serie 46 Total 277
-------------------------	---	-------------------------	--

2. Serie 1 Skott 6 	1: 9.0 → 2: 9.7 → 3: 9.5 ↑ 4: 8.1 → 5: 8.9 → Serie 43 Total 320		
------------------------	---	--	--

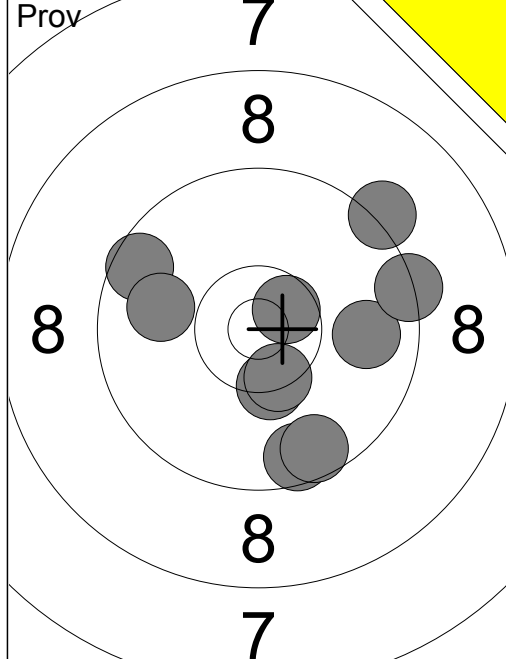

1:	9.6	↘
2:	10.6x	↗
3:	9.6	↘
4:	9.6	↖
5:	9.2	↗
6:	10.4x	↘
7:	9.8	→
8:	9.4	→
9:	10.4x	↘
10:	9.9	←

Serie	93
Total	184

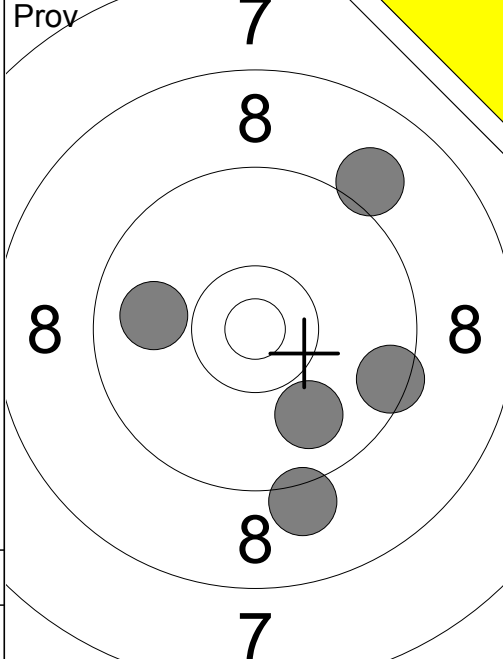

11:	9.9	←
12:	9.5	↗
13:	9.1	↘
14:	9.9	↘
15:	9.0	↗

Serie	45
Total	184

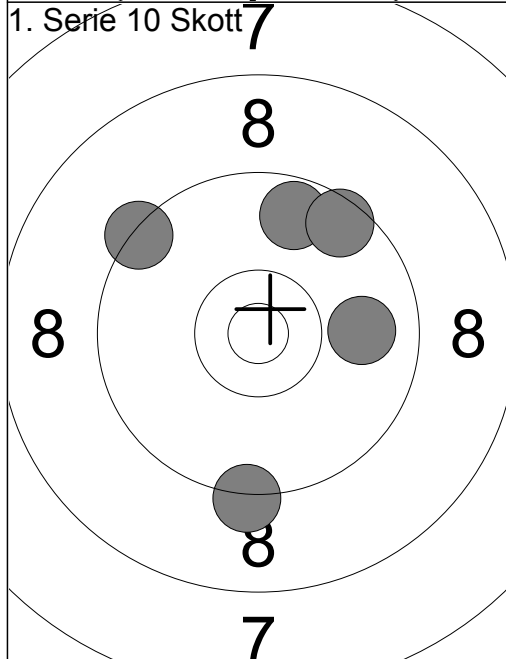

1:	9.9	→
2:	9.4	↖
3:	9.7	↗
4:	9.5	↗
5:	9.3	↘

Serie	45
Total	229

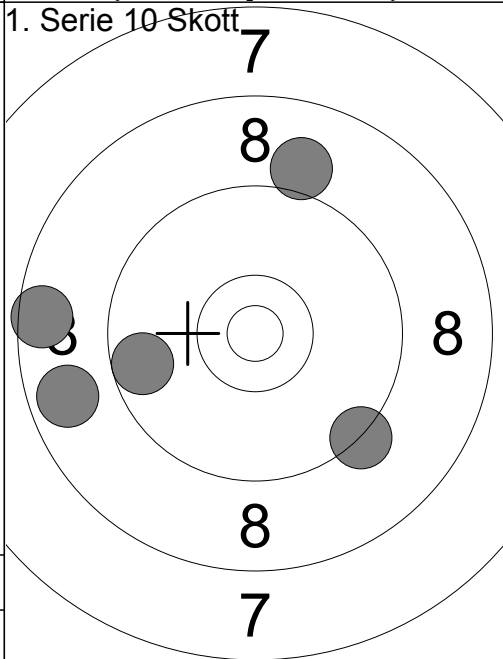

6:	9.3	↘
7:	8.7	←
8:	8.6	←
9:	9.7	←
10:	9.0	↗

Serie	43
Total	272

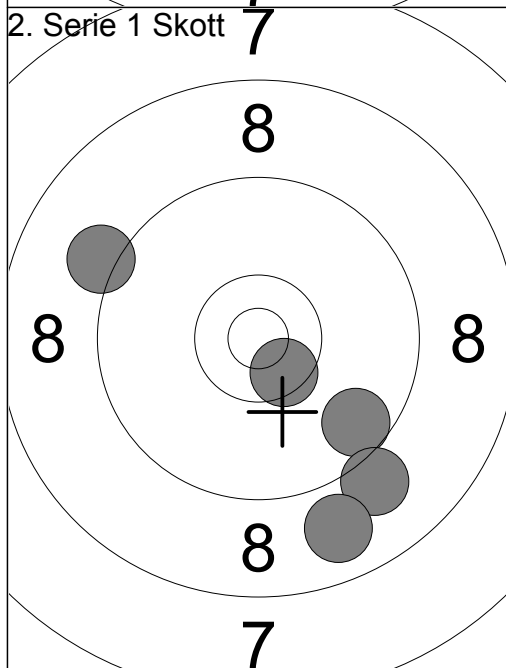

1:	10.5x	↘
2:	9.6	↘
3:	9.1	↗
4:	9.1	↘
5:	8.8	↘

Serie	45
Total	317

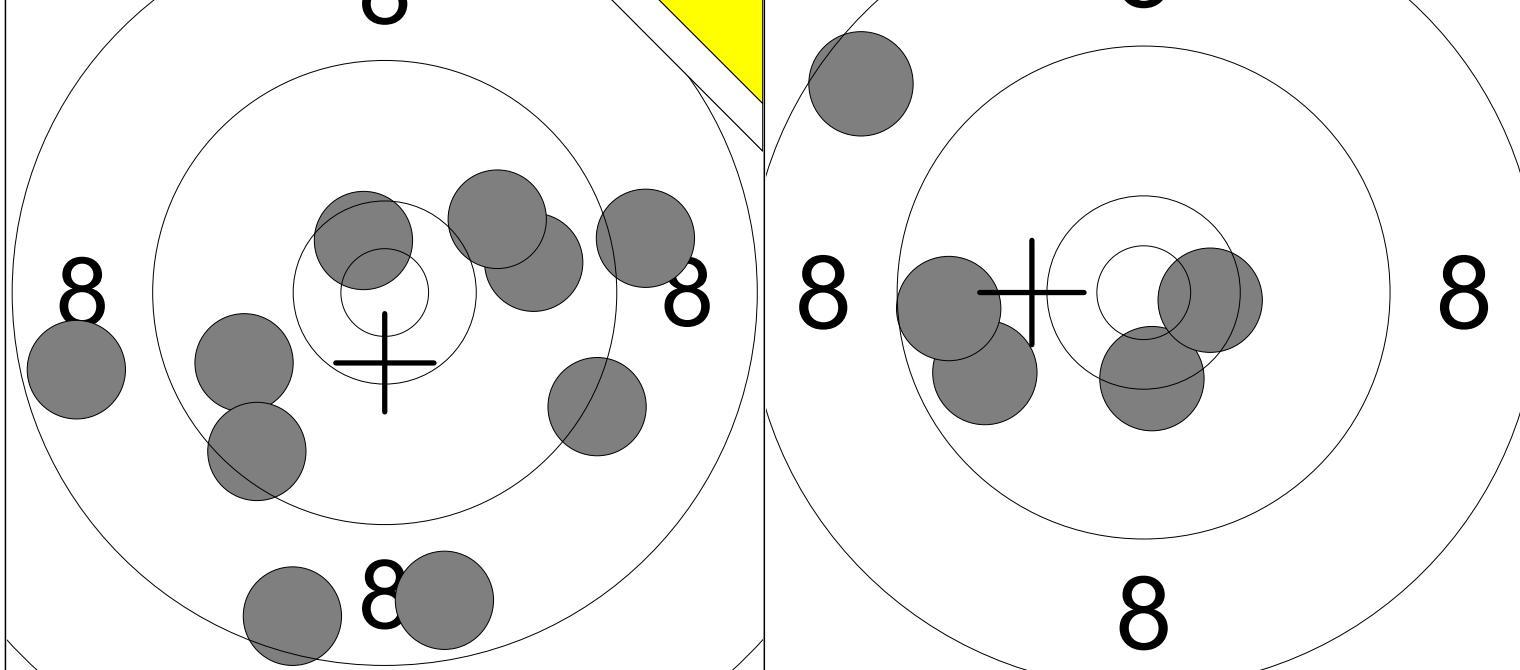

1: 8.7 ↓	6: 8.7 ←	Serie	89
2: 9.9 →	7: 9.5 ↘		
3: 8.6 ↓	8: 10.0 ↗	Total	184
4: 9.1 →	9: 10.6x ↗		
5: 9.8 ←	10: 9.2 ↘		

1: 8.6 ↖	Serie	46
2: 10.4x ↓		
3: 9.8 ←	Total	230
4: 9.6 ←		
5: 10.5x →		

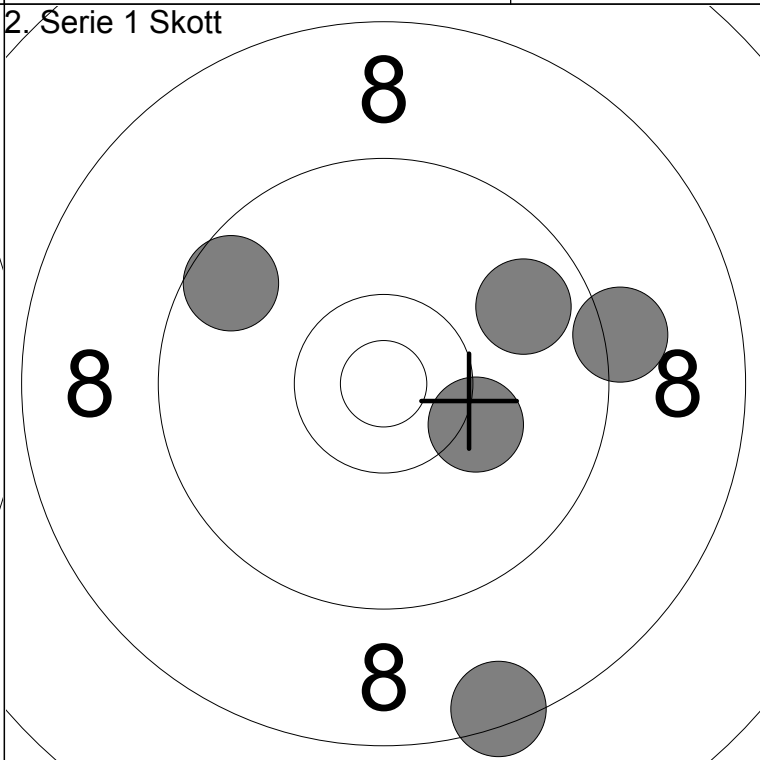
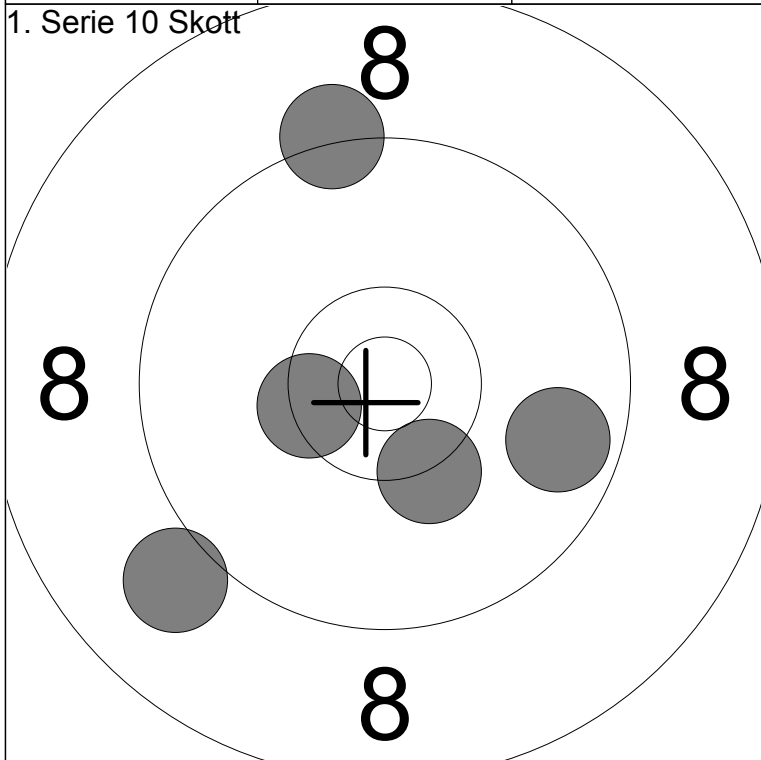

6: 10.3x ↓	Serie	47
7: 9.7 →		
8: 9.0 ↘	Total	277
9: 10.4x ←		
10: 9.3 ↑		

1: 10.2 →	Serie	45
2: 9.6 ↖		
3: 9.8 ↗	Total	322
4: 8.4 ↓		
5: 9.2 →		

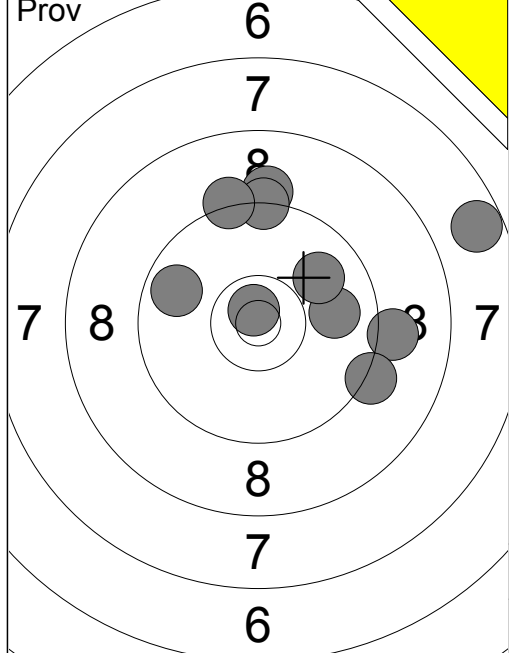

1:	7.7	→
2:	9.9	→
3:	9.1	→
4:	9.1	↑
5:	9.2	→
6:	9.7	←
7:	10.8x	↑
8:	9.3	↑
9:	9.9	↗
10:	9.2	↑
Serie		89
Total		183

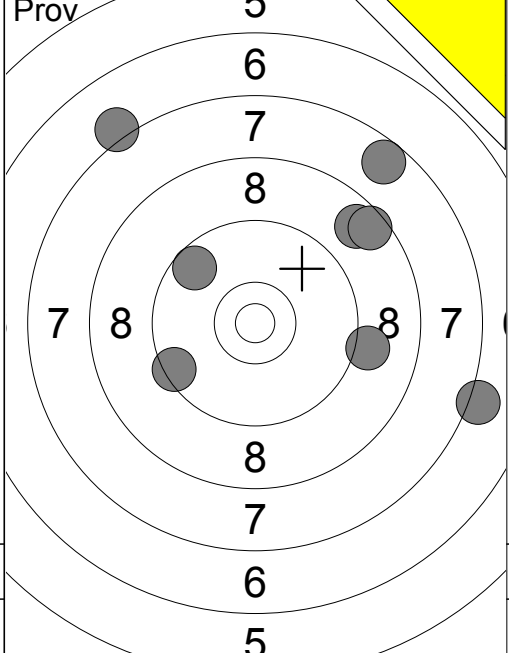

11:	7.6	↗
12:	9.6	↖
13:	7.1	↖
14:	9.5	↙
15:	9.1	→
16:	7.2	→
17:	8.7	↗
18:	8.6	↗
Serie		64
Total		183

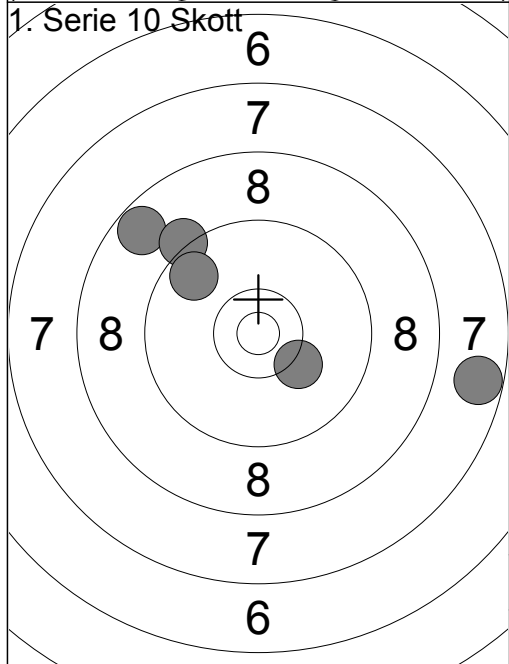

1:	8.7	↖
2:	7.7	→
3:	10.2	↘
4:	9.2	↗
5:	9.7	↗
Serie		43
Total		226

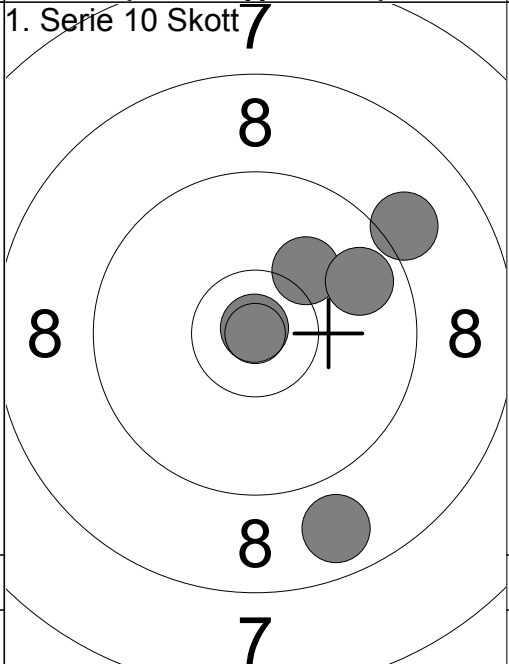

6:	10.1	↗
7:	10.9x	↑
8:	9.1	↗
9:	9.8	↗
10:	8.8	↓
Serie		46
Total		272

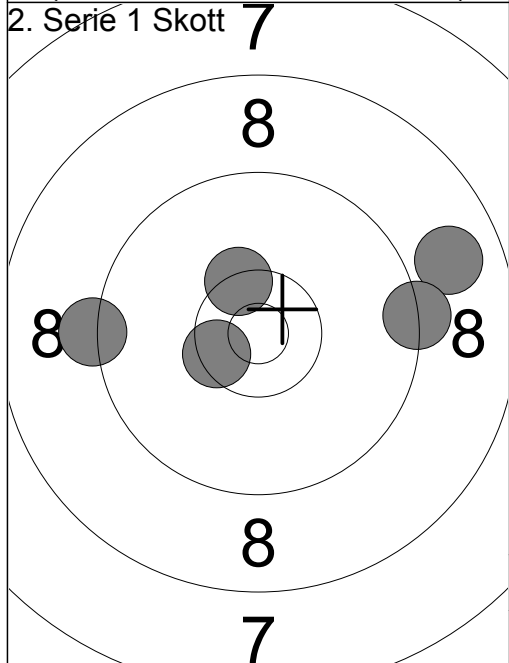

1:	8.9	→
2:	9.3	←
3:	10.5x	↙
4:	10.4x	↑
5:	9.3	→
Serie		46
Total		318

<p>Prov</p>	<p>1: 10.3x ↖                  2: 8.2 ←                  3: 10.3 ↓                  4: 8.9 ↓                  5: 9.5 ↓                  6: 9.5 ↓                  7: 10.0 ↗                  8: 9.5 ↓                  9: 10.7x ↙                  10: 8.8 ↙</p>	<p>Prov</p>
	<p>11: 9.2 ↘                  12: 9.6 ↘</p>	
Serie 91	Serie 18	
Total 190	Total 190	

<p>1. Serie 10 Skott 7</p>	<p>1: 9.9 ←                  2: 9.6 ↓                  3: 8.6 ←                  4: 10.5x ↙                  5: 10.5x ↙</p>	<p>1. Serie 10 Skott 7</p>
		<p>6: 9.8 ↘                  7: 10.3x ↓                  8: 9.5 ←                  9: 9.3 ↘                  10: 8.4 ↙</p>
Serie 46	Serie 45	
Total 236	Total 281	

<p>2. Serie 1 Skott 7</p>	<p>1: 9.6 ←                  2: 9.5 ←                  3: 9.4 ←                  4: 10.5x →                  5: 9.6 →</p>	
Serie 46		
Total 327		



<p>Prov</p>	<p>1: 9.5 →                  2: 9.9 ←                  3: 10.2 ←                  4: 9.6 ↖                  5: 9.3 ↑                  6: 10.4x →                  7: 9.8 ↑                  8: 10.1 →                  9: 10.2 ↘                  10: 10.8x ↑</p>	<p>Prov</p>
Serie 95		Serie 29
Total 190		Total 190

<p>1. Serie 10 Skott</p>	<p>1: 9.9 ←                  2: 10.6x ↘                  3: 9.2 ←                  4: 10.6x ↑                  5: 10.0 ←</p>	<p>1. Serie 10 Skott</p>
Serie 48		Serie 49
Total 238		Total 287

<p>2. Serie 1 Skott</p>	<p>1: 9.3 ↑                  2: 9.9 ↖                  3: 9.8 ←                  4: 9.8 ↘                  5: 8.8 ↘</p>	
Serie 44		
Total 331		

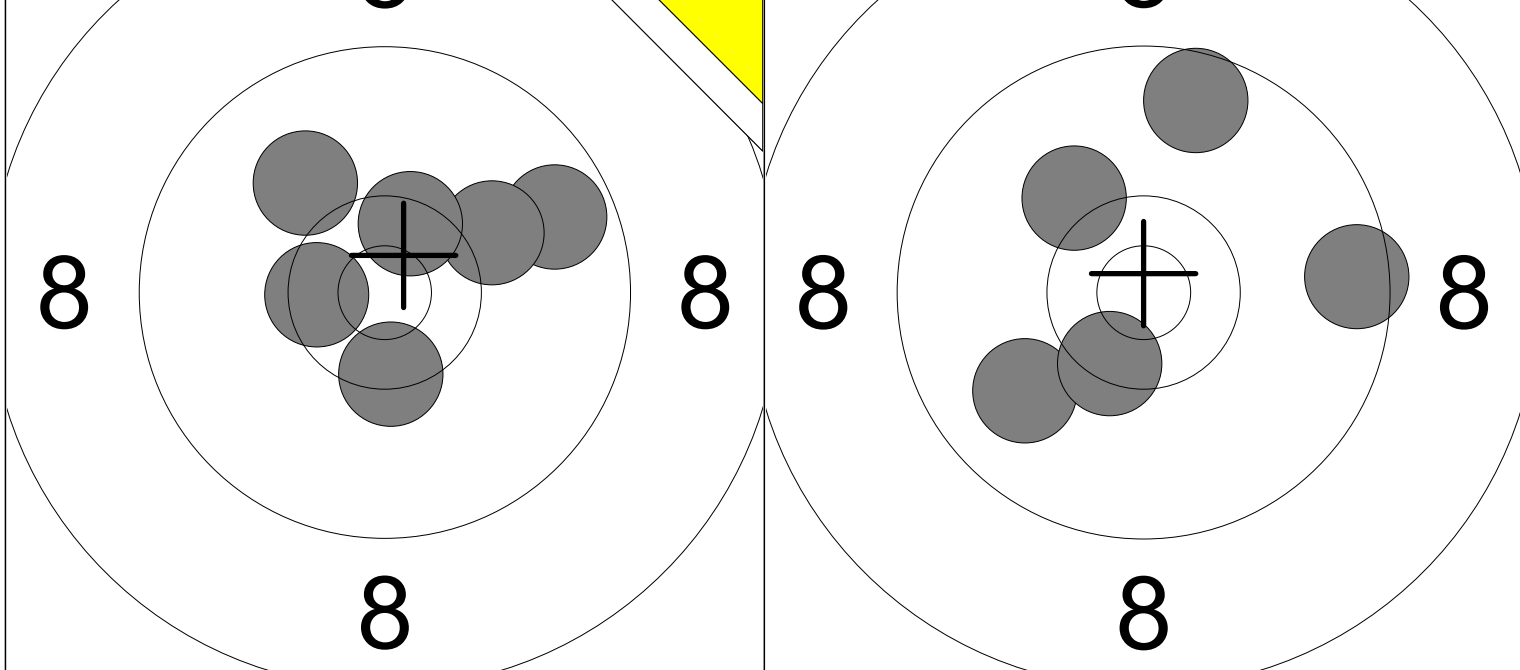

1: 10.4x ↓	6: 10.5x ↑	Serie	59	1: 9.9 ↙	Serie	47
2: 10.0 ↗		Total	188	2: 10.4x ↓	Total	235
3: 9.7 →				3: 9.5 →		
4: 10.1 ↗				4: 10.2 ↗		
5: 10.5x ←				5: 9.6 ↑		

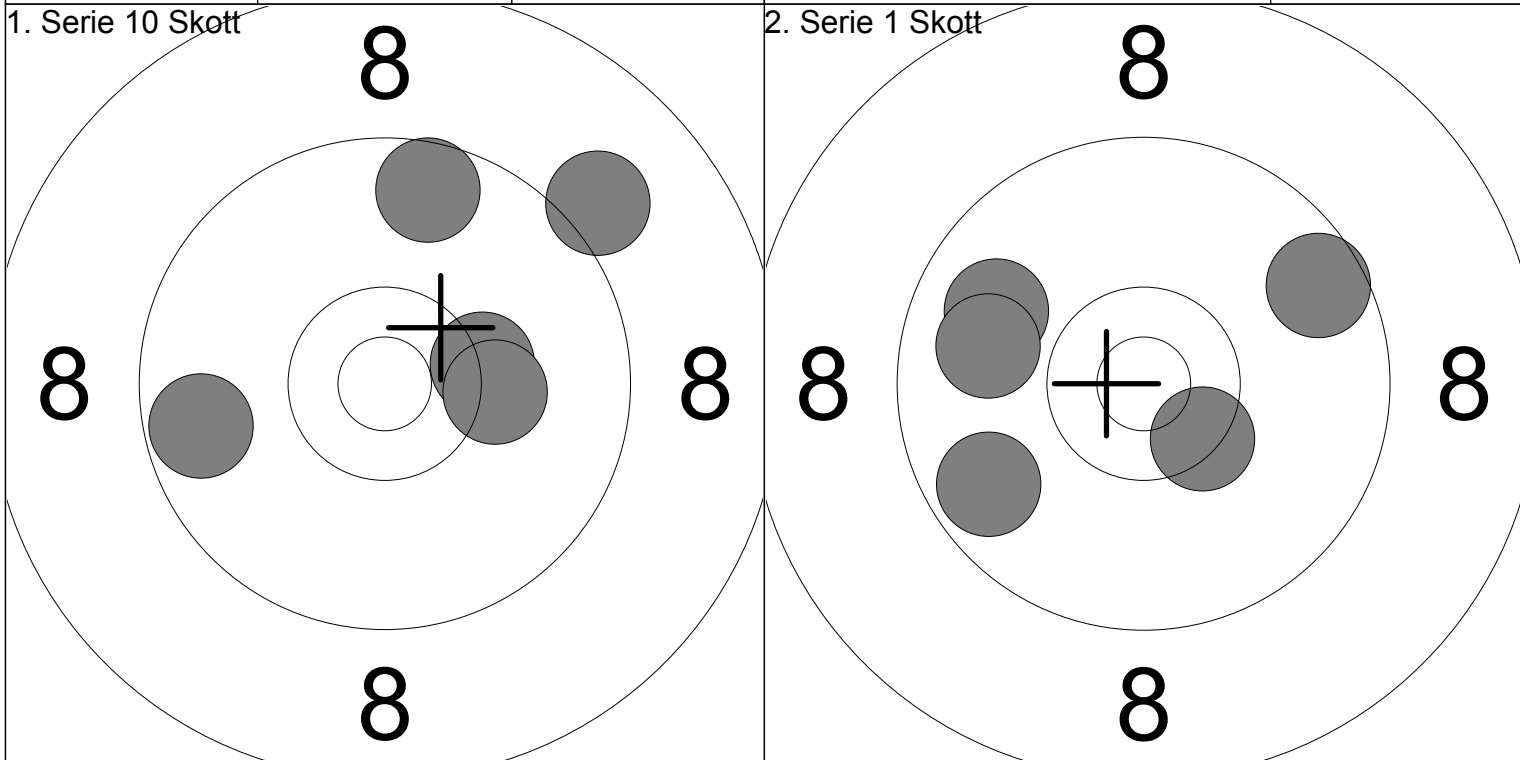

6: 10.3 →	1: 9.7 ↙	Serie	47	2: 10.4x ↓	Serie	46
7: 10.2 →		Total	282	3: 9.8 ↗	Total	328
8: 9.6 ↑				4: 9.6 →		
9: 9.7 ←				5: 9.9 ←		
10: 9.1 ↗						

<p>Prov</p>	<p>1: 10.6x ↙                  2: 9.0 ↘                  3: 10.2 ↘                  4: 9.6 ↘                  5: 8.5 ↘                  6: 10.1 ↗                  7: 10.6x ↘                  8: 9.7 →                  9: 9.8 ↗                  10: 9.3 ↘</p>	<p>Prov</p>	<p>11: 10.2 ↗                  12: 10.1 ↘</p>
Serie 93		Serie 20	
Total 187		Total 187	

<p>1. Serie 10 Skott</p>	<p>1: 9.7 →                  2: 9.4 ↗                  3: 10.5x ↗                  4: 9.8 ←                  5: 10.8x ←</p>	<p>1. Serie 10 Skott</p>	<p>6: 9.8 ↗                  7: 9.3 ↗                  8: 9.5 ↘                  9: 8.9 ↗                  10: 10.5x ↗</p>
Serie 47		Serie 45	
Total 234		Total 279	

<p>2. Serie 1 Skott</p>	<p>1: 10.0 →                  2: 9.8 ↗                  3: 9.9 ↗                  4: 9.6 ↘                  5: 8.9 ↘</p>		
Serie 45			
Total 324			

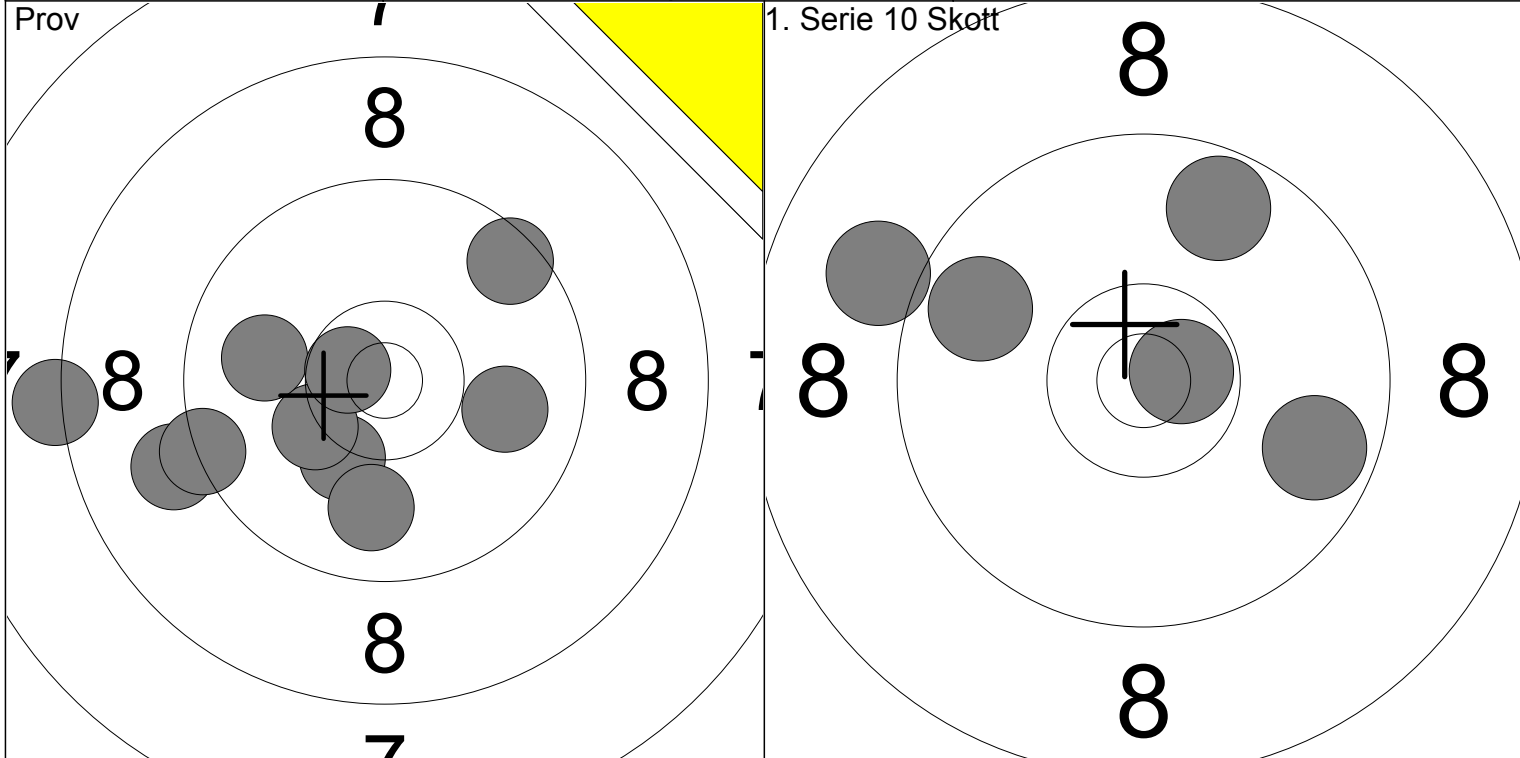

1: 9.1 ←	6: 8.2 ←	Serie	93	1: 10.7x →	Serie	46
2: 10.2 ↘	7: 9.9 ↓			2: 9.7 ↗		
3: 9.9 →	8: 10.3 ←	Total	185	3: 9.8 ↖	Total	231
4: 9.5 ↗	9: 10.0 ←			4: 9.0 ↗		
5: 9.3 ←	10: 10.6x ←			5: 9.7 ↘		

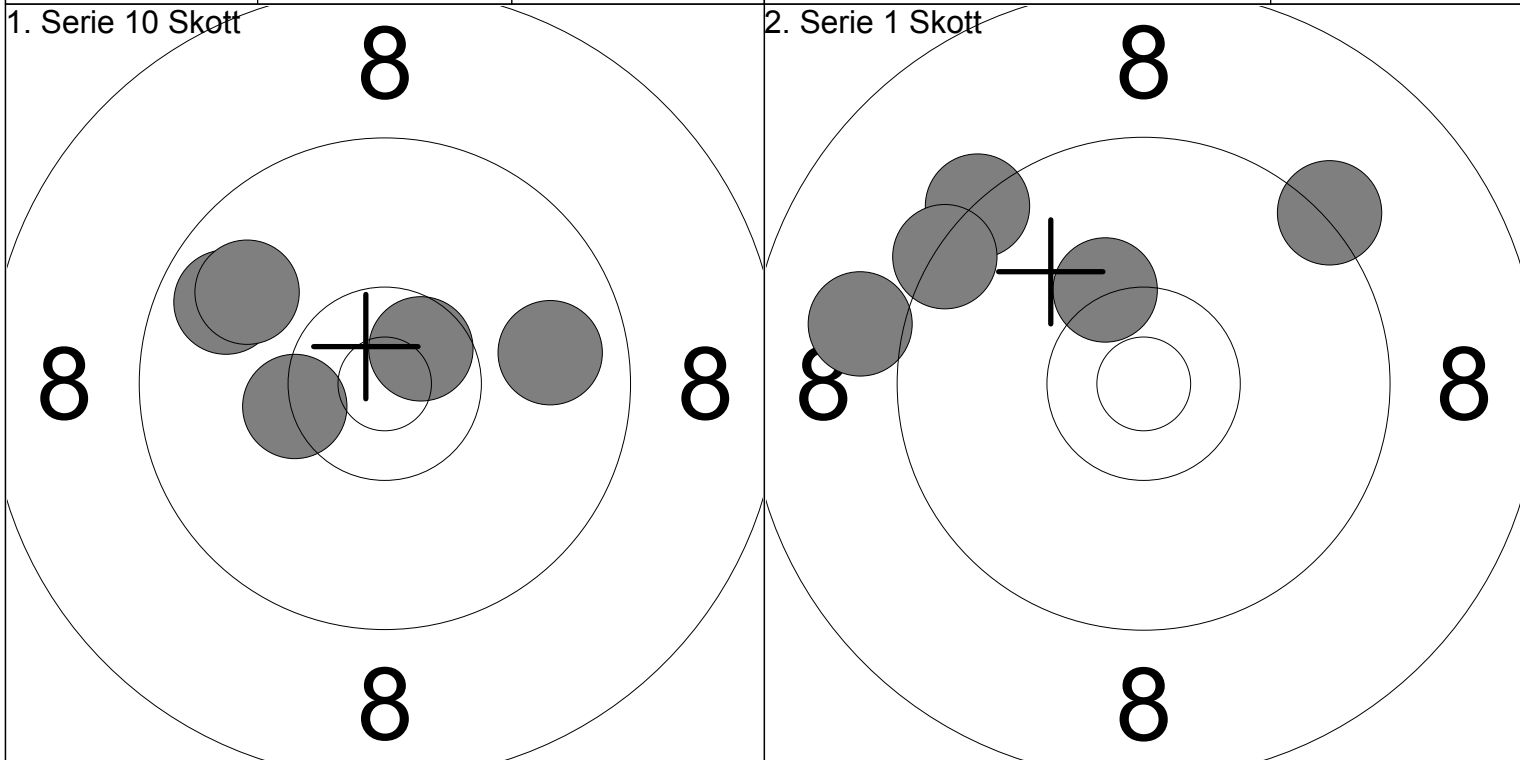

6: 10.3x ←	Serie	47	1: 9.0 ←	Serie	46
7: 9.8 ↖			2: 9.3 ↗		
8: 9.8 ↖	Total	278	3: 9.4 ↖	Total	324
9: 9.8 →			4: 10.3 ↗		
10: 10.6x ↗			5: 9.3 ↗		

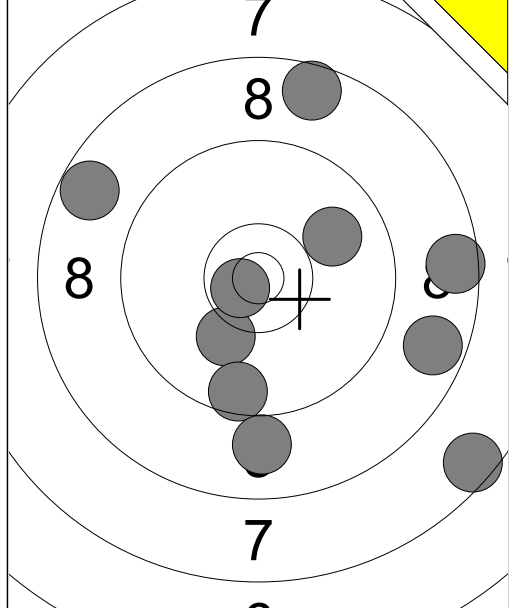

1:	10.1	↘
2:	9.9	↗
3:	10.7x	↙
4:	8.6	↑
5:	9.6	↓
6:	8.7	↖
7:	8.6	→
8:	7.5	↘
9:	8.7	↗
10:	8.9	↓
Serie		85
Total		180

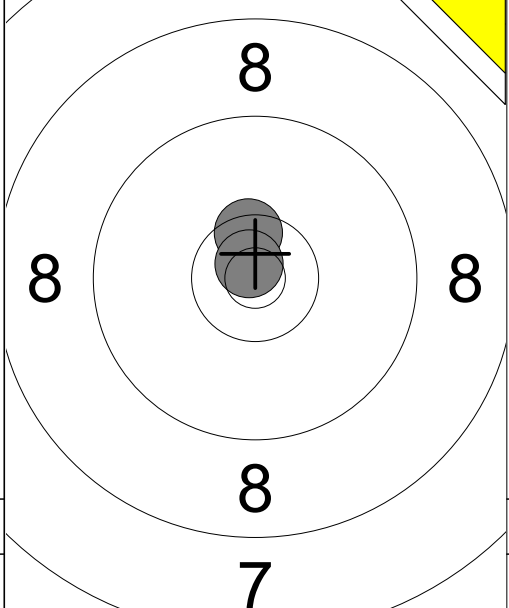

11:	10.5x	↑
12:	10.8x	↗
Serie		20
Total		180

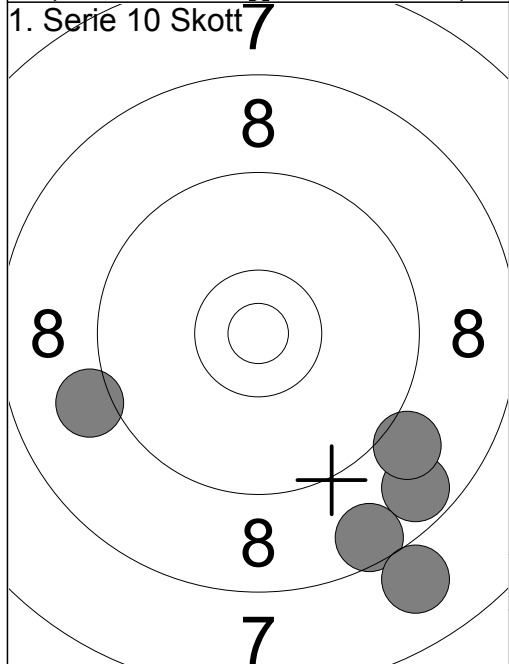

1:	8.7	↘
2:	9.0	↘
3:	9.1	↖
4:	8.6	↘
5:	8.0	↘
Serie		42
Total		222

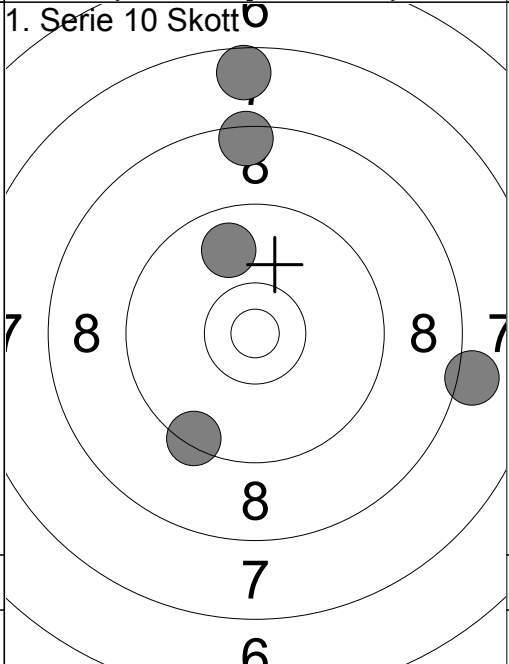

6:	9.4	↘
7:	9.8	↑
8:	8.1	→
9:	7.6	↑
10:	8.5	↑
Serie		41
Total		263

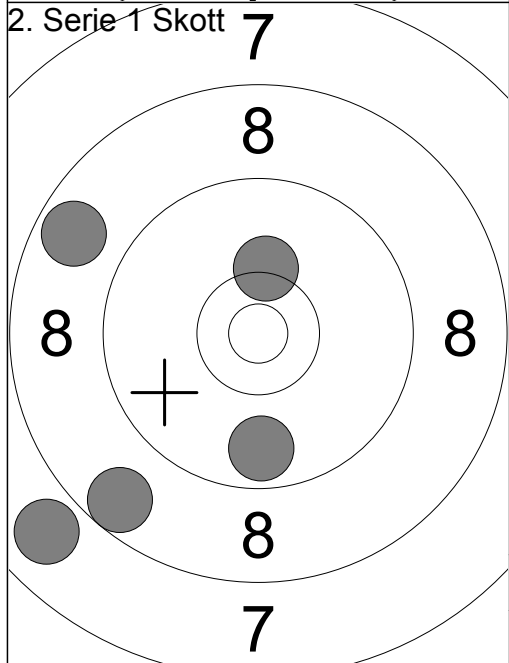

1:	10.2	↑
2:	8.7	↖
3:	8.6	↘
4:	9.7	↓
5:	7.9	↙
Serie		42
Total		305

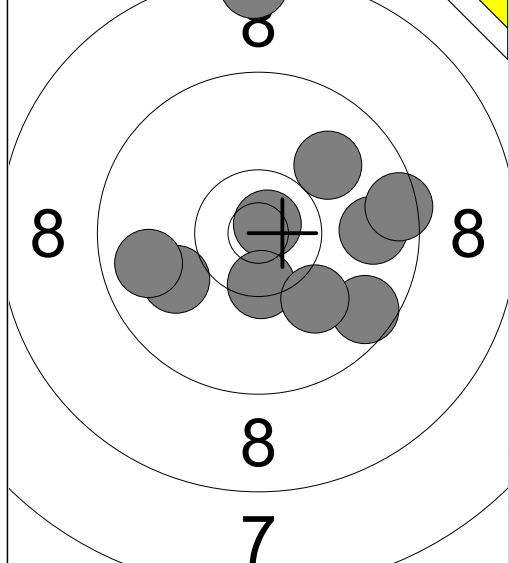

1:	8.4	↑
2:	10.8x	↗
3:	10.0	↖
4:	9.6	↘
5:	10.4x	↓
6:	9.8	→
7:	9.8	←
8:	9.5	→
9:	10.1	↘
10:	10.0	↗
Serie		94
Total		179

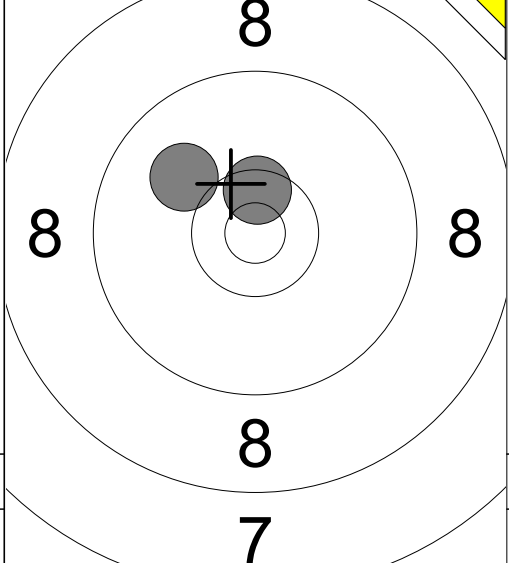

11:	10.0	↖
12:	10.5x	↑
Serie		20
Total		179

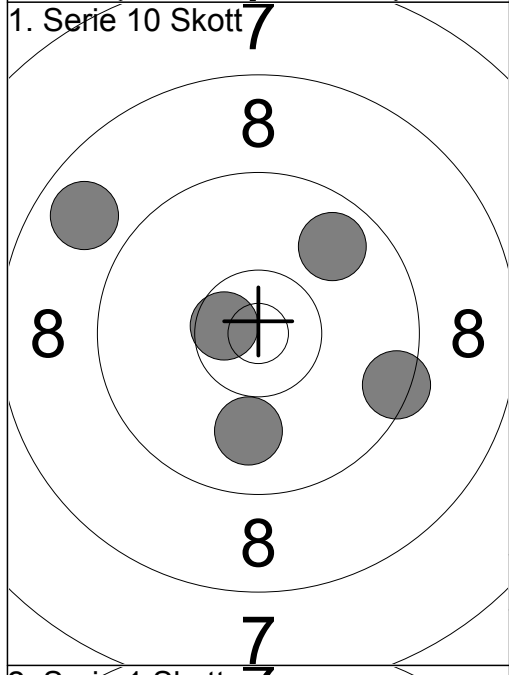

1:	9.4	→
2:	8.8	↖
3:	9.8	↗
4:	9.9	↓
5:	10.6x	↖
Serie		45
Total		224

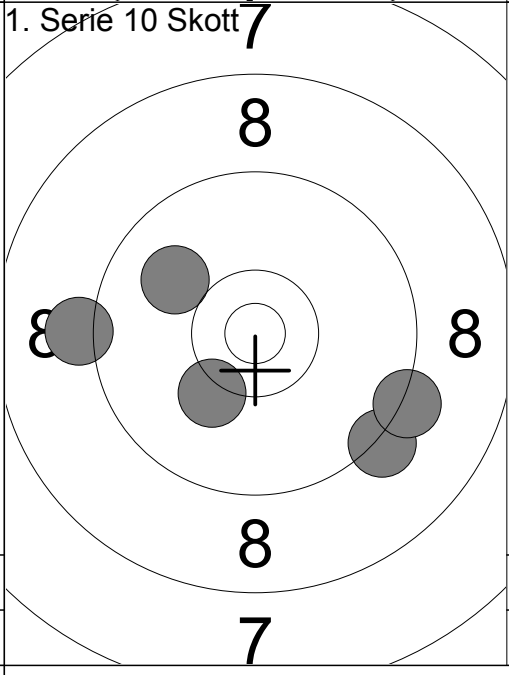

6:	10.2	↖
7:	9.2	↘
8:	9.2	←
9:	10.0	↗
10:	9.2	↘
Serie		47
Total		271

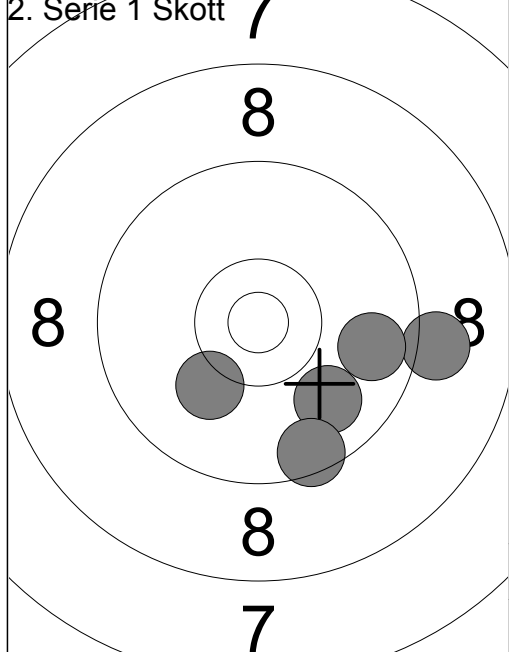

1:	9.1	→
2:	9.9	↘
3:	10.1	↖
4:	9.8	→
5:	9.5	↘
Serie		46
Total		317

<p>Prov</p>	<p>1: 9.8 →                  2: 10.9x ↖                  3: 9.4 ↗                  4: 9.6 ↗                  5: 10.9x ↖                  6: 10.4x ↓                  7: 8.9 ↗                  8: 8.7 ↗                  9: 9.6 ←                  10: 8.3 →</p> <p>Serie 90 Total 178</p>	<p>Prov</p>	<p>11: 10.3x →                  12: 9.1 →                  13: 9.6 ↗                  14: 10.7x ↑                  15: 9.5 →</p> <p>Serie 47 Total 178</p>
-------------	--	-------------	--

<p>1. Serie 10 Skott</p>	<p>1: 10.0 →                  2: 9.8 ↓                  3: 9.1 ↗                  4: 10.4x ↑                  5: 10.0 →</p> <p>Serie 48 Total 226</p>	<p>1. Serie 10 Skott</p>	<p>6: 10.6x ↓                  7: 9.7 ↙                  8: 9.7 ↗                  9: 10.6x →                  10: 9.0 ↖</p> <p>Serie 47 Total 273</p>
--------------------------	---	--------------------------	--

<p>2. Serie 1 Skott</p>	<p>1: 9.7 ←                  2: 10.7x ↗                  3: 10.1 ↗                  4: 9.4 ↓                  5: 10.3 ↓</p> <p>Serie 48 Total 321</p>		
-------------------------	---	--	--

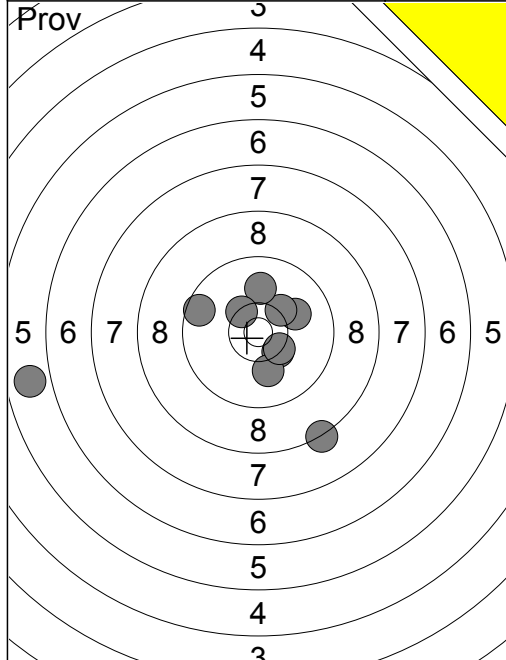

- 1: 10.1 →
- 2: 5.8 ←
- 3: 9.6 ←
- 4: 10.3x ↘
- 5: 10.3 ↗
- 6: 10.0 ↑
- 7: 8.3 ↘
- 8: 10.1 ↘
- 9: 10.4x ↗
- 10: 10.4x ↘

Serie 92  
Total 177

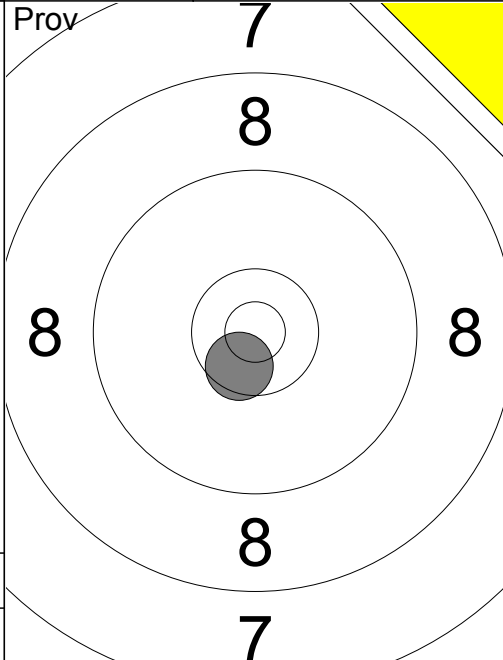

- 11: 10.6x ↘

Serie 10  
Total 177

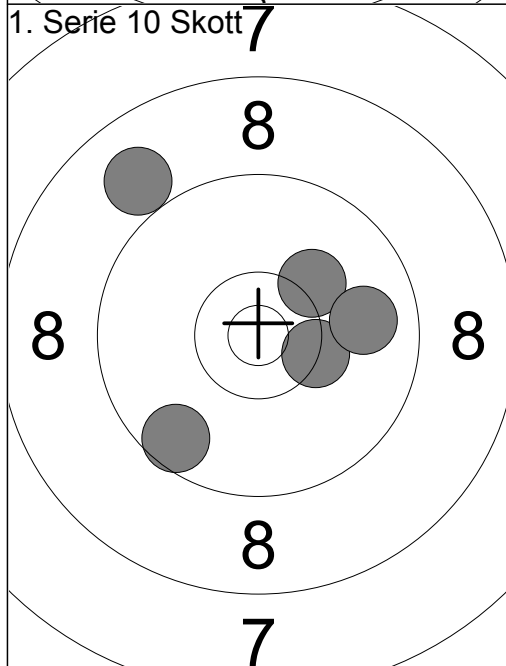

- 1: 10.3x →
- 2: 9.6 ↘
- 3: 10.2 ↗
- 4: 9.9 →
- 5: 8.9 ↗

Serie 46  
Total 223

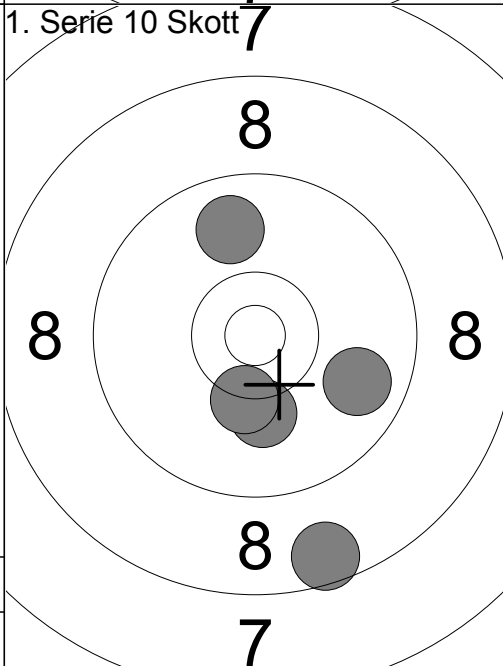

- 6: 10.1 ↘
- 7: 9.8 ↗
- 8: 8.6 ↘
- 9: 9.8 ↑
- 10: 10.3 ↘

Serie 46  
Total 269

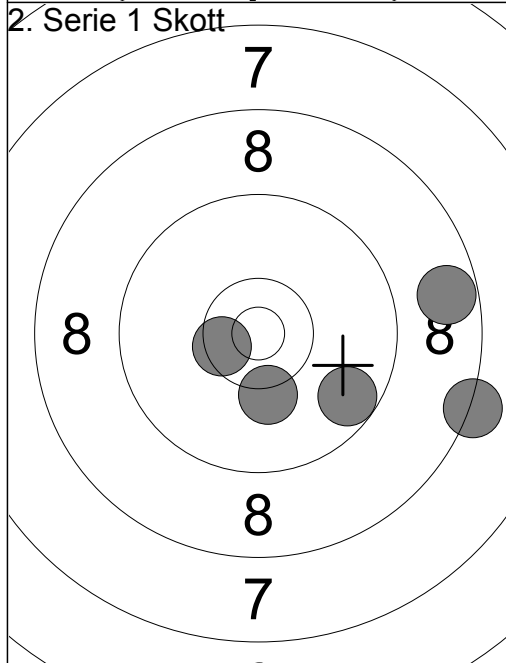

- 1: 10.5x ←
- 2: 10.2 ↘
- 3: 9.7 ↘
- 4: 8.3 →
- 5: 8.7 →

Serie 45  
Total 314



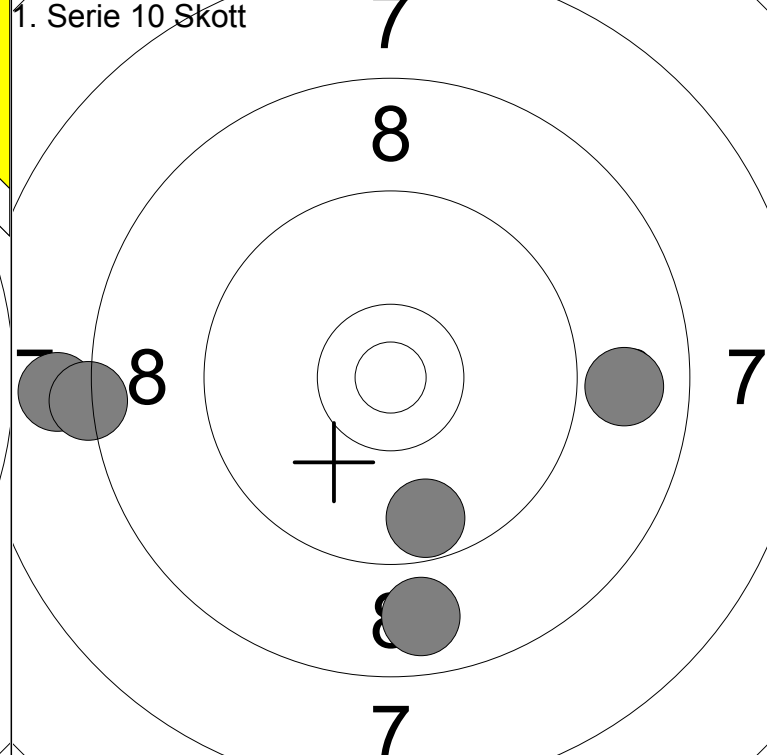
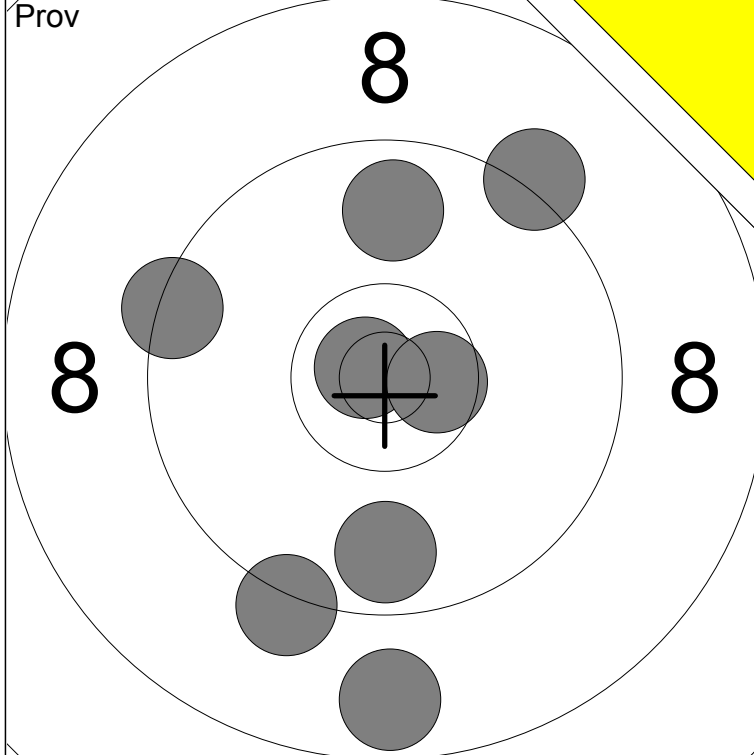

1: 8.7	↓	6: 10.8x	↖	Serie	73
2: 9.4	←	7: 10.6x	→		
3: 9.2	↙	8: 9.8	↑	Total	184
4: 9.2	↗				
5: 9.7	↓				

1: 8.0	←	Serie	41
2: 8.8	↓		
3: 9.7	↙	Total	225
4: 8.9	→		
5: 8.3	←		

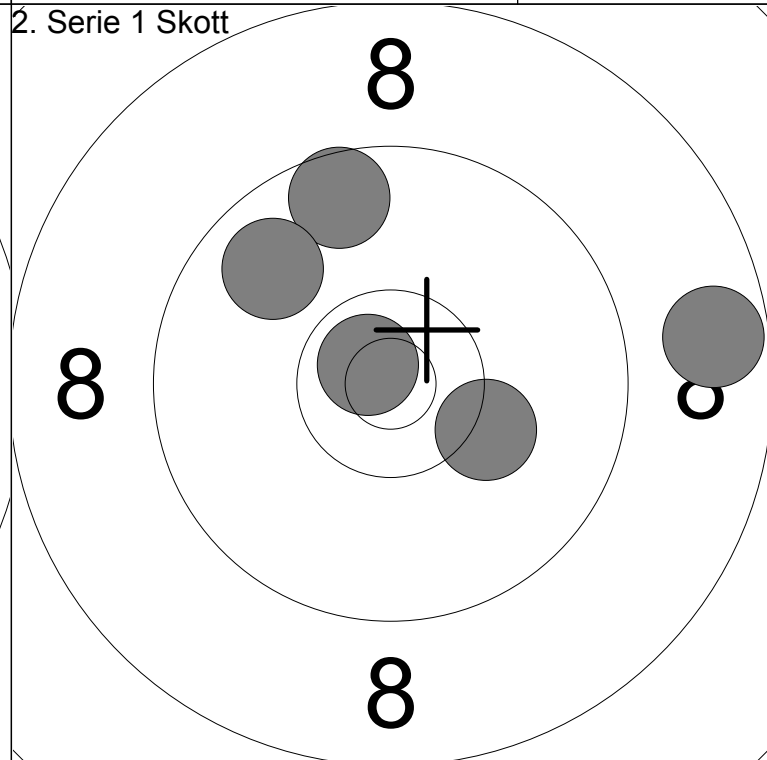
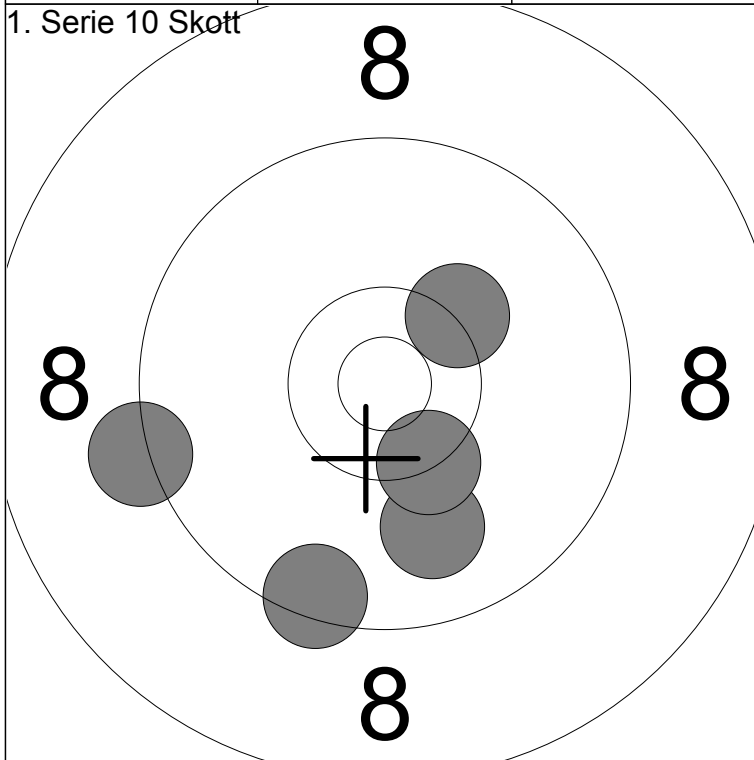

6: 9.2	←	Serie	47
7: 9.9	↓		
8: 9.4	↙	Total	272
9: 10.3x	↘		
10: 10.3	↗		

1: 9.6	↗	Serie	46
2: 9.8	↗		
3: 10.7x	↗	Total	318
4: 10.2	↘		
5: 8.7	→		

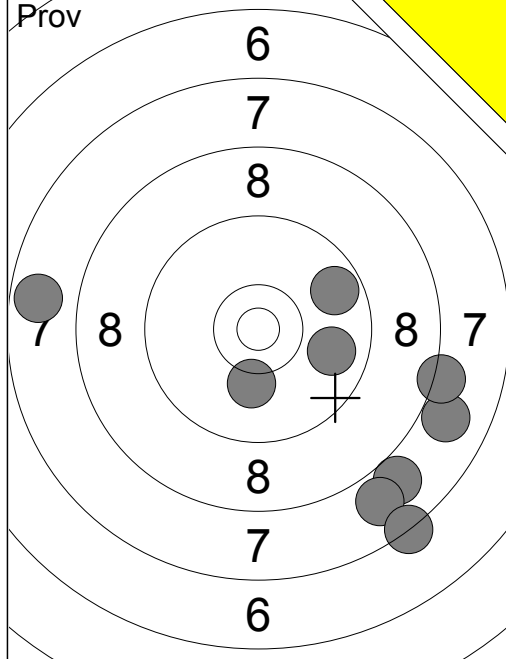

2:	7.7	←
3:	8.0	↘
4:	7.9	→
5:	7.9	↘
6:	10.1	↓
7:	8.2	→
8:	7.3	↘
9:	9.8	→
10:	9.7	↗
Serie		72
Total		178

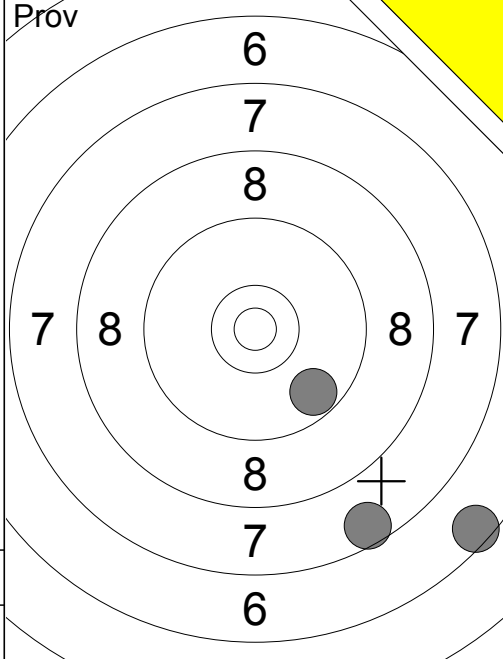

11:	6.5	↘
12:	9.7	↘
13:	7.6	↘
Serie		22
Total		178

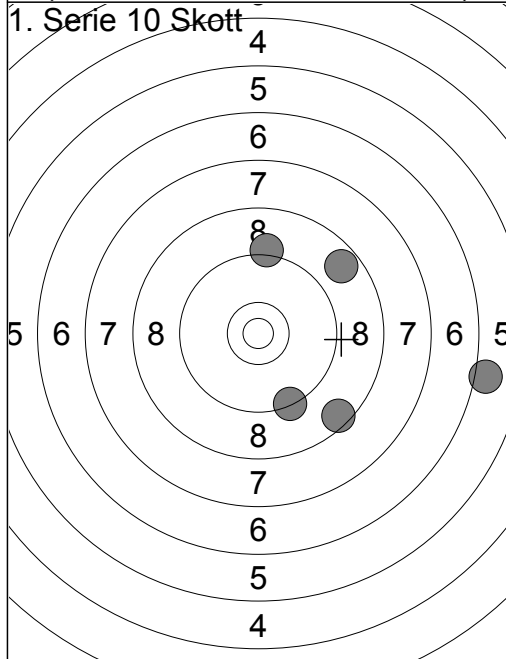

1:	6.1	→
2:	9.2	↑
3:	8.7	↗
4:	9.3	↘
5:	8.5	↘
Serie		40
Total		218

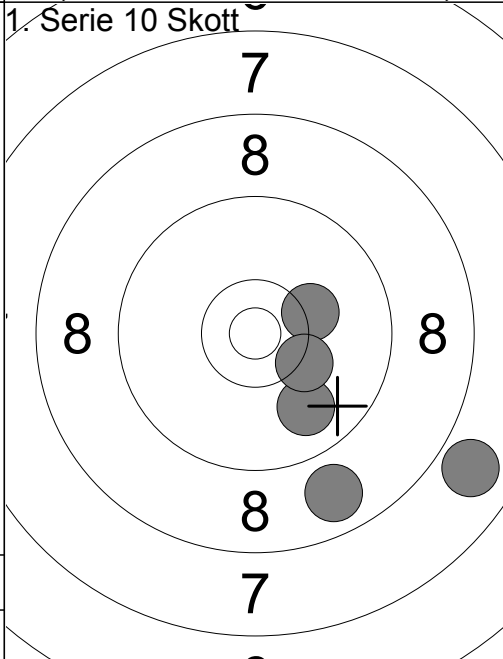

6:	9.9	↘
7:	10.2	↗
8:	7.9	↘
9:	8.8	↘
10:	10.3	↘
Serie		44
Total		262

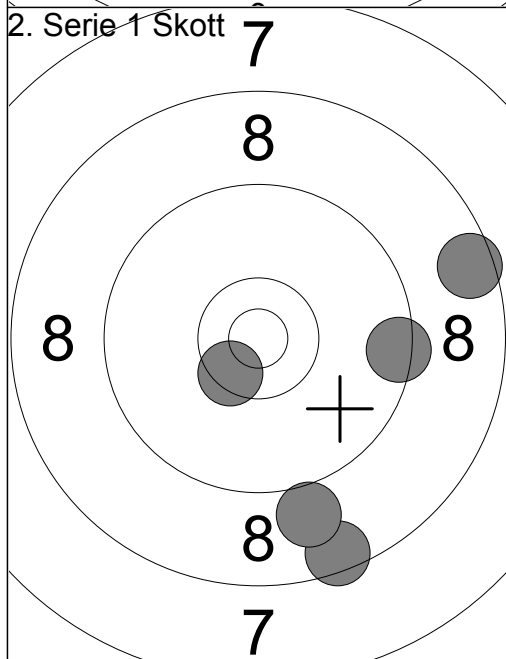

1:	8.6	↗
2:	9.4	→
3:	8.5	↘
4:	9.0	↘
5:	10.5x	↘
Serie		44
Total		306

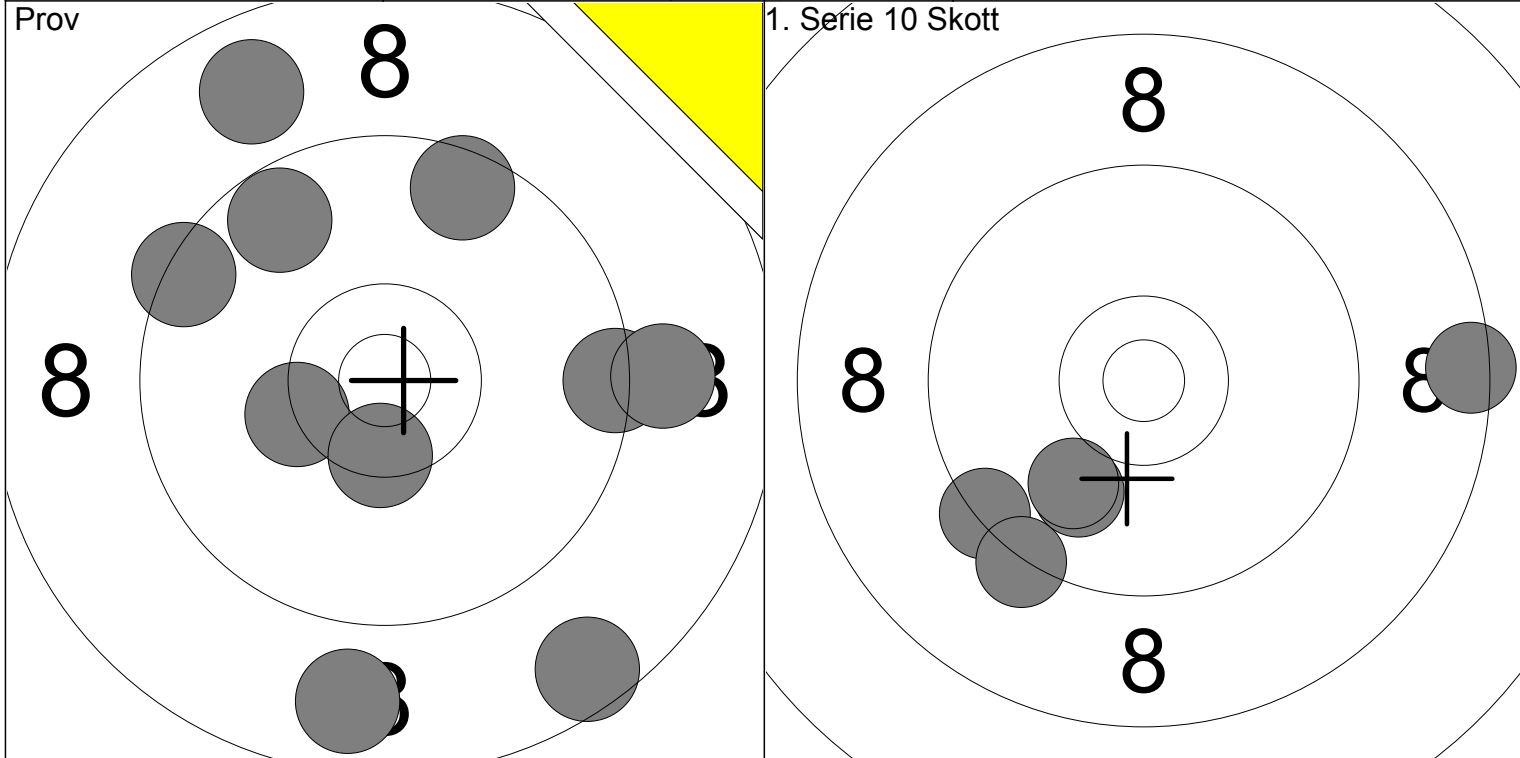

1: 8.8 ↓	6: 8.6 ↓			1: 8.4 →			
2: 10.3x ←	7: 10.4x ↓	Serie	89	2: 9.4 ↙		Serie	46
3: 9.6 ↗	8: 9.4 →	Total	174	3: 9.3 ↘		Total	220
4: 9.7 ↗	9: 8.8 ↗			4: 10.0 ↘			
5: 9.4 ↖	10: 9.1 →			5: 10.0 ↘			

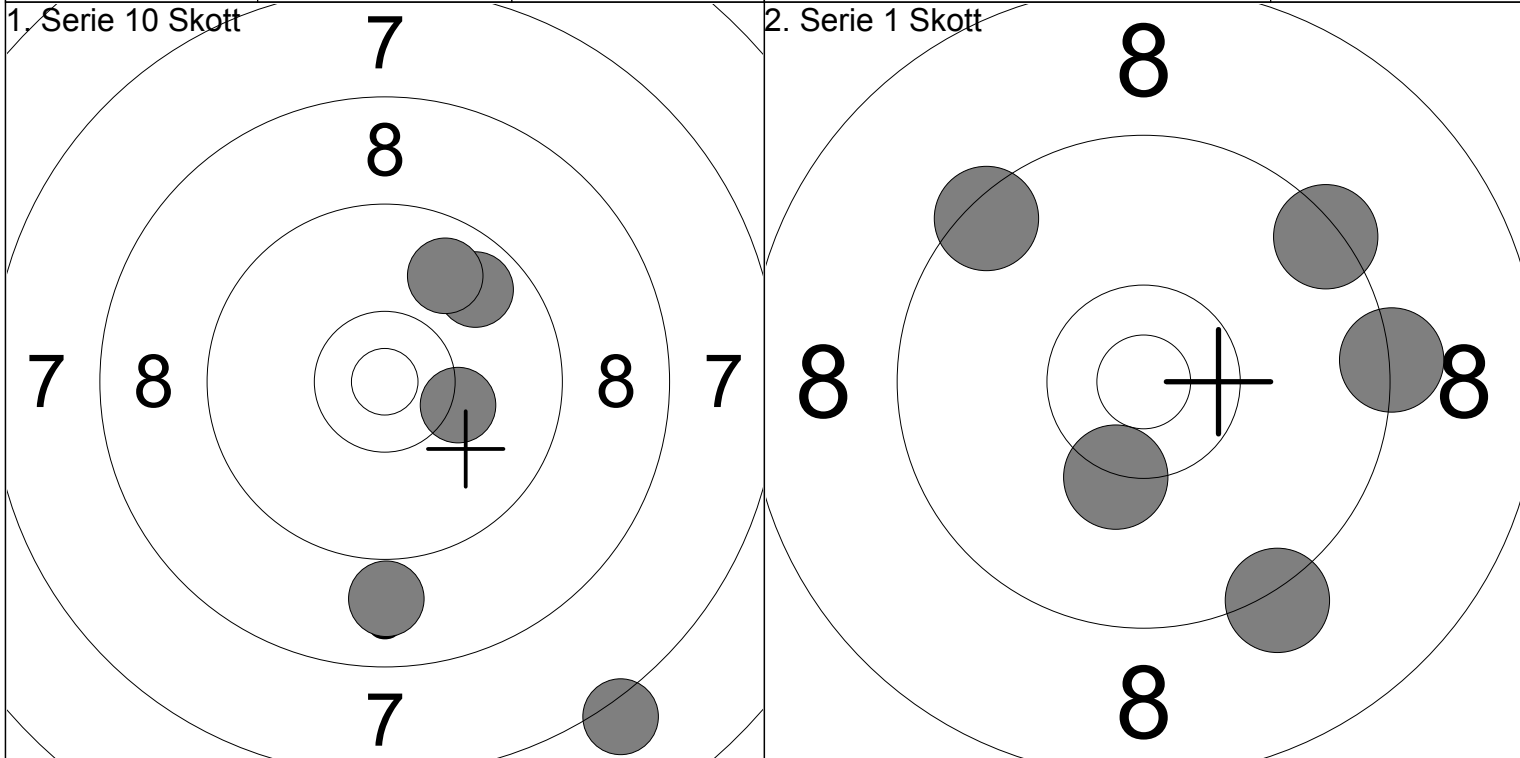

6: 10.2 →	7: 8.9 ↓			1: 9.2 ↓			
8: 9.8 ↗	9: 7.1 ↘	Serie	43	2: 10.3 ↘		Serie	46
10: 9.8 ↗		Total	263	3: 9.3 →		Total	309
				4: 9.4 ↗			

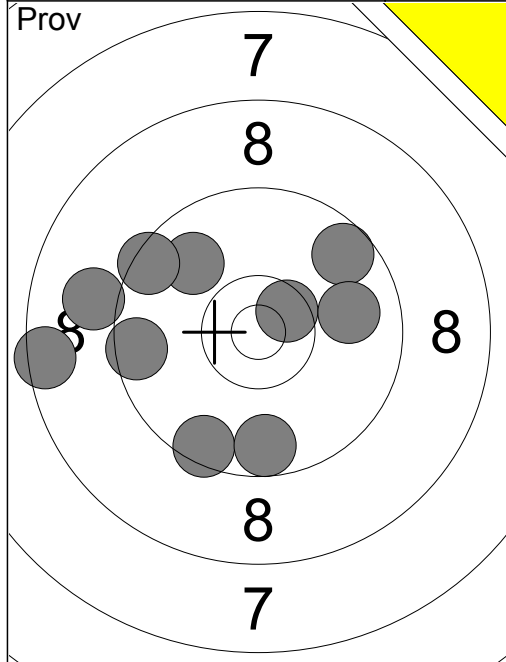

1:	9.6	↗
2:	9.9	↖
3:	9.5	↖
4:	10.5x	↗
5:	9.5	↖
6:	9.9	→
7:	9.5	↘
8:	9.7	↘
9:	9.0	↖
10:	8.5	↖
Serie		90
Total		191

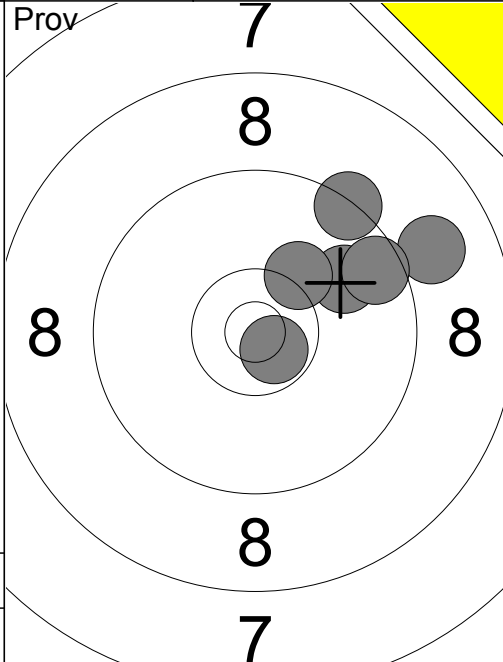

11:	9.9	↗
12:	10.7x	↘
13:	9.0	→
14:	9.3	↗
15:	9.6	↗
16:	10.2	↗
Serie		56
Total		191

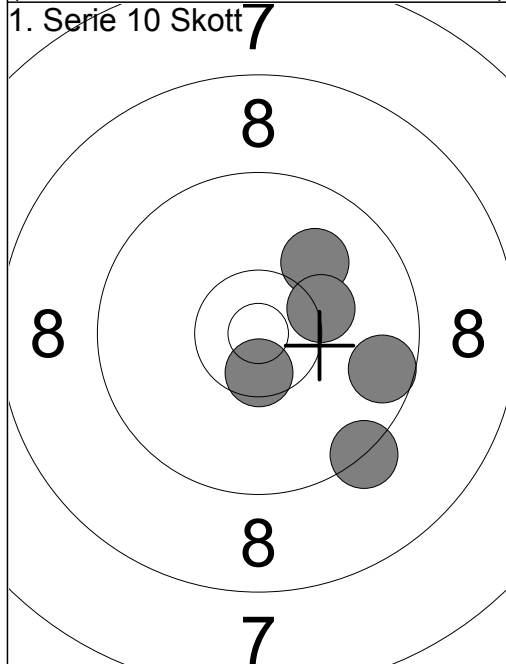

1:	10.0	↗
2:	10.5x	↘
3:	9.3	↘
4:	9.6	→
5:	10.3	↗
Serie		48
Total		239

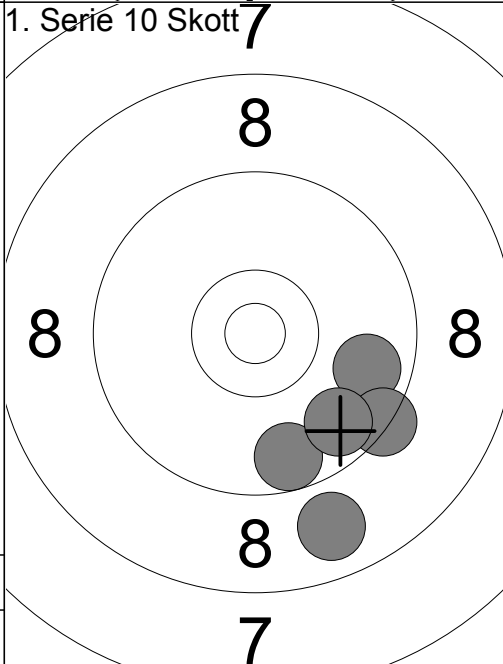

6:	9.8	→
7:	9.4	↘
8:	9.6	↘
9:	8.8	↘
10:	9.7	↘
Serie		44
Total		283

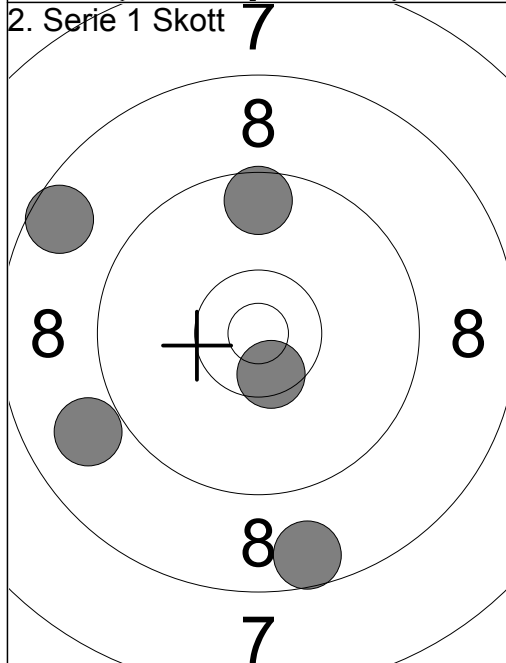

1:	8.6	↖
2:	9.6	↑
3:	8.9	↖
4:	10.5x	↘
5:	8.6	↘
Serie		43
Total		326

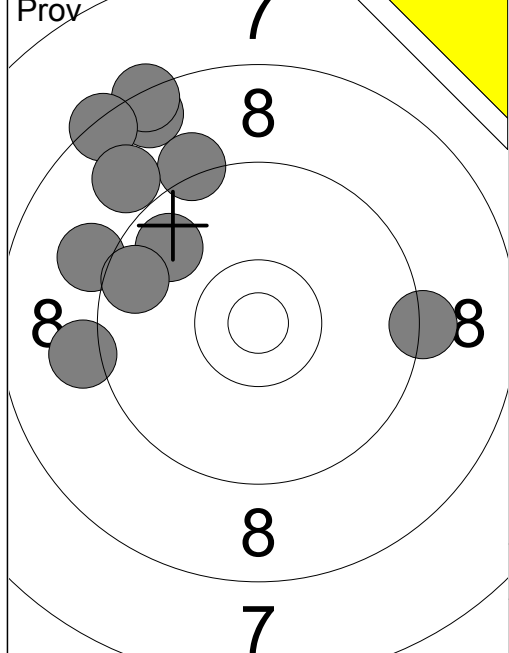

1:	8.5	↗
2:	9.2	↗
3:	9.1	↖
4:	9.8	↗
5:	8.4	↗
6:	9.6	↖
7:	8.4	↗
8:	9.3	→
9:	9.1	←
10:	8.9	↖
Serie	86	
Total	188	

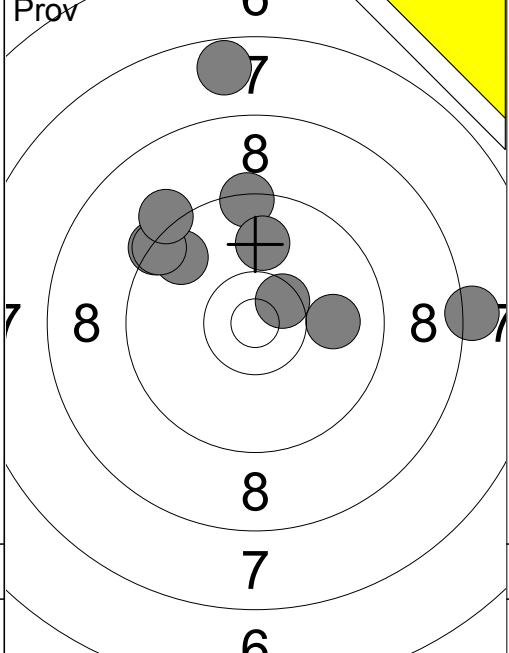

11:	7.7	↑
12:	8.2	→
13:	10.5x	↗
14:	9.7	↖
15:	9.4	↖
16:	10.0	→
17:	9.4	↖
18:	9.4	↑
19:	9.9	↑
20:	9.2	↖
Serie	89	
Total	188	

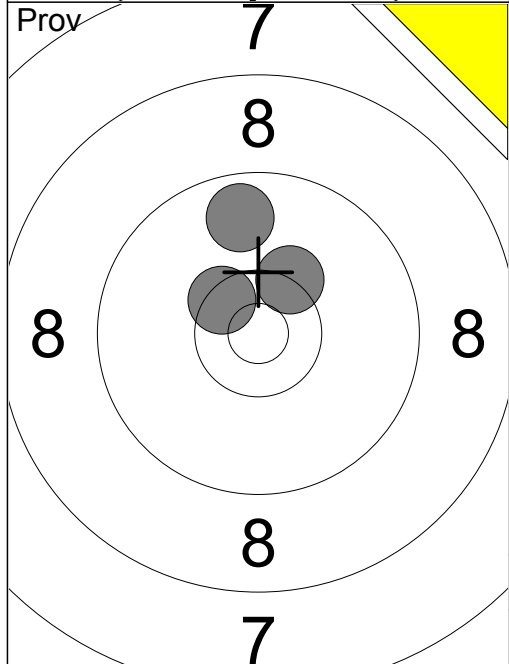

21:	10.4x	↖
22:	9.7	↑
23:	10.3x	↗
Serie	29	
Total	188	

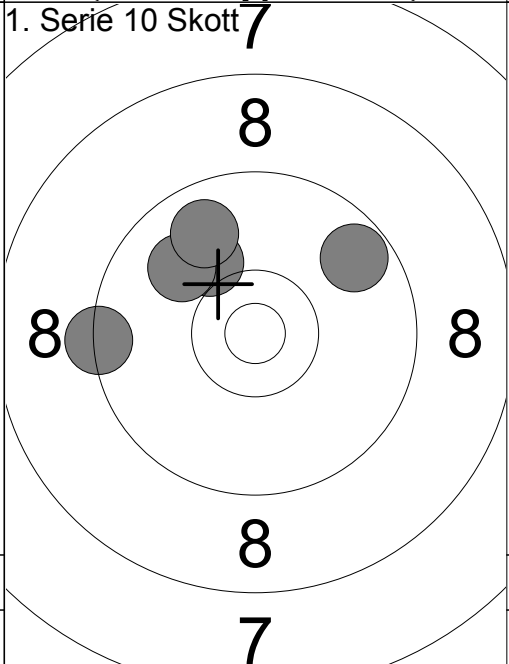

1:	9.4	←
2:	10.1	↗
3:	9.9	↖
4:	9.7	↗
5:	9.8	↗
Serie	46	
Total	234	

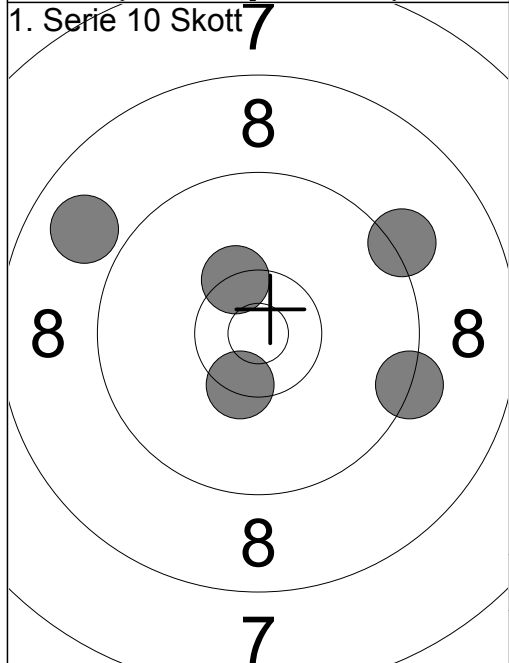

6:	8.9	↖
7:	10.4x	↘
8:	9.3	→
9:	10.4x	↗
10:	9.2	↗
Serie	46	
Total	280	

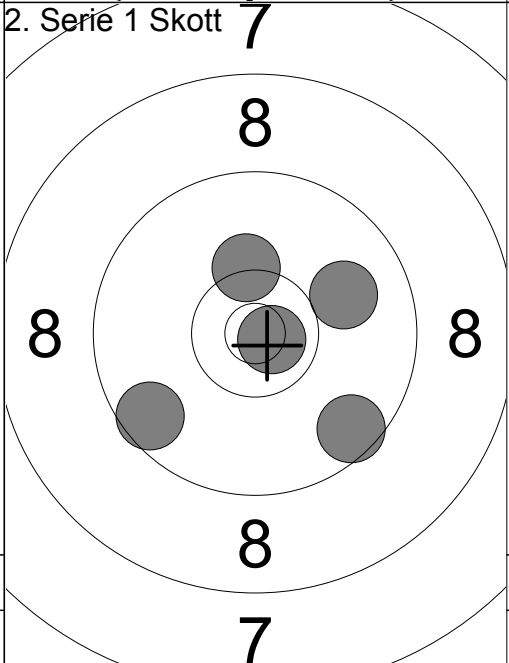

1:	10.3	↑
2:	10.8x	→
3:	9.6	↖
4:	9.6	↘
5:	10.0	↗
Serie	48	
Total	328	

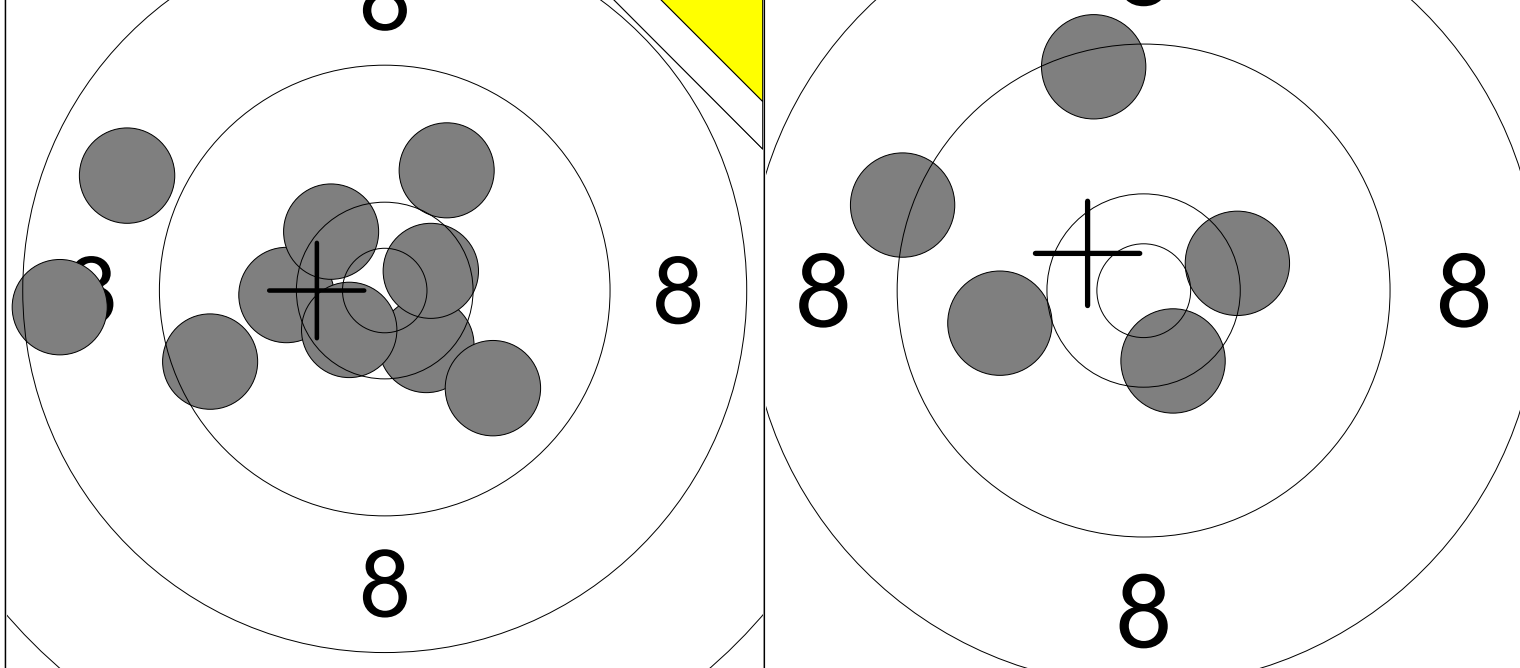

1: 8.6 ←	6: 9.9 ↘			1: 9.2 ←			
2: 9.6 ←	7: 10.4x ↗	Serie	94	2: 10.0 ←	Serie	48	Total
3: 10.2 ←	8: 10.6x →			3: 9.4 ↑			
4: 10.4x ↘	9: 10.0 ↗	Total	186	4: 10.3x →			
5: 8.9 ↗	10: 10.6x ↘			5: 10.4x ↘			

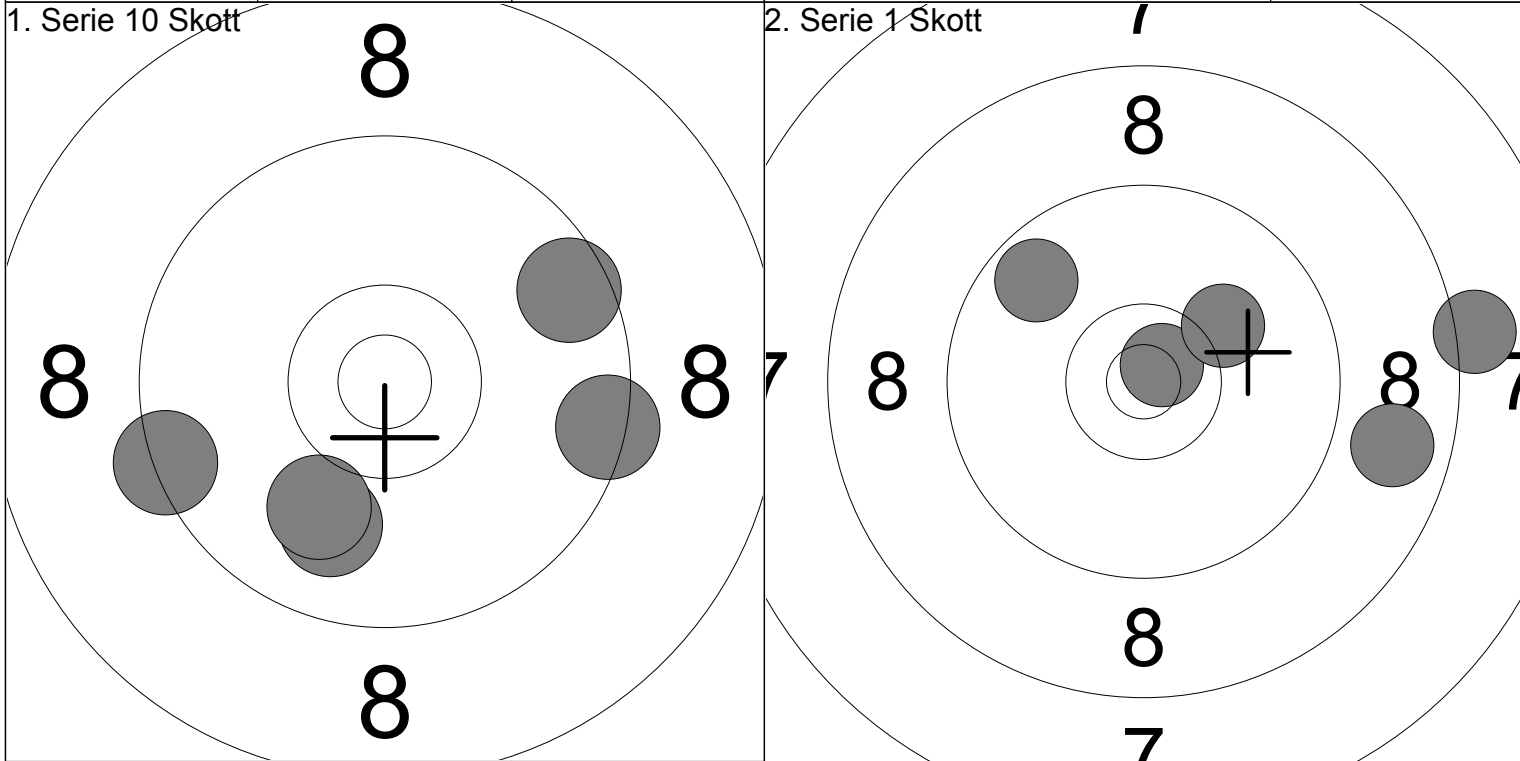

6: 9.6 ↗				1: 9.7 ↗			
7: 9.9 ↘	Serie	46	Total	2: 8.8 →	Serie	45	Total
8: 9.4 ←				3: 10.7x ↗			
9: 9.4 →				4: 10.1 ↗			
10: 10.0 ↘				5: 8.1 →			

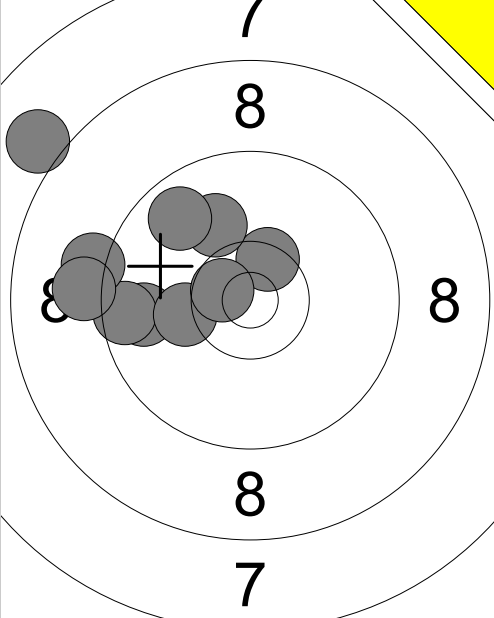
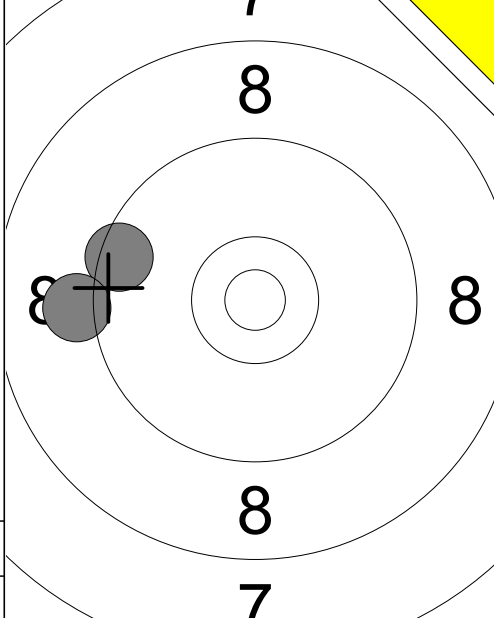
<p>Prov</p> 	<p>1: 10.5x ↗                  2: 9.8 ←                  3: 10.0 ↗                  4: 9.6 ←                  5: 8.0 ↗                  6: 9.8 ↗                  7: 9.2 ←                  8: 10.2 ←                  9: 10.6x ↙                  10: 9.1 ←</p>	<p>Prov</p> 
	11: 9.5 ← 12: 9.1 ←	
Serie 93		Serie 18
Total 180		Total 180

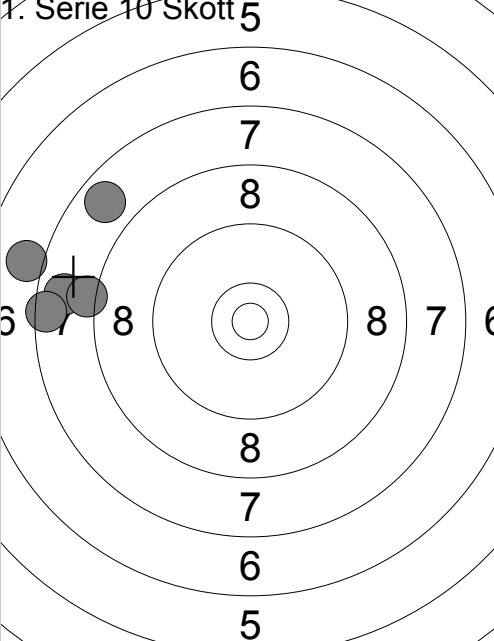
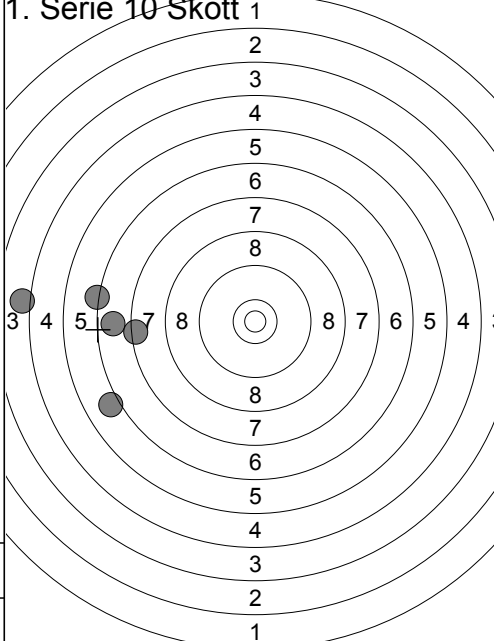
<p>1. Serie 10 Skott 5</p> 	<p>1: 7.8 ←                  2: 7.0 ←                  3: 7.8 ↗                  4: 7.5 ←                  5: 8.1 ←</p>	<p>1. Serie 10 Skott 1</p> 
		6: 6.8 ← 7: 6.2 ← 8: 4.1 ← 9: 6.0 ← 10: 7.4 ←
Serie 36		Serie 29
Total 216		Total 245

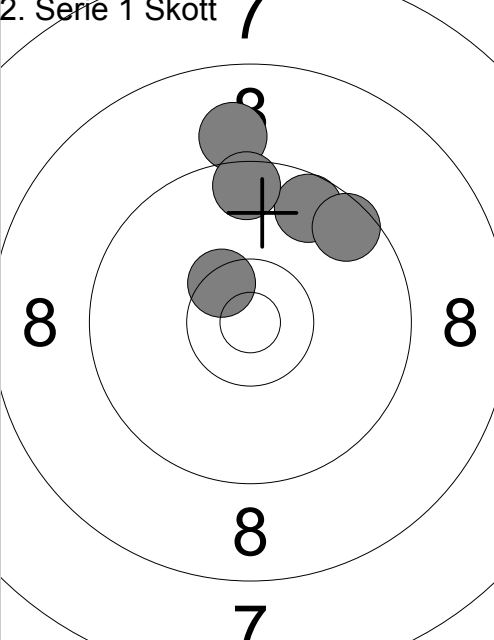
<p>2. Serie 1 Skott 7</p> 	<p>1: 9.6 ↗                  2: 9.0 ↑                  3: 10.4x ↙                  4: 9.6 ↗                  5: 9.5 ↑</p>	
Serie 46		
Total 291		

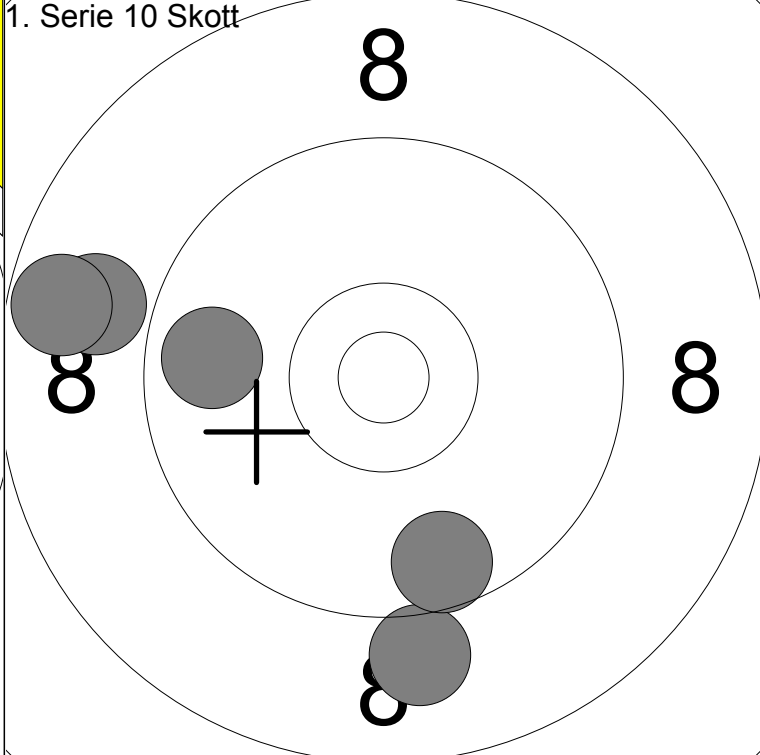
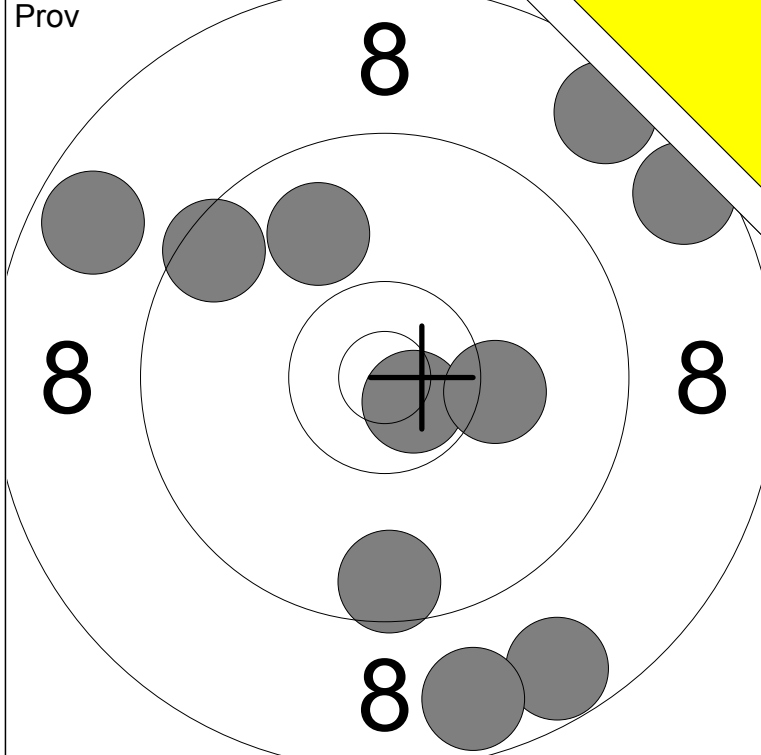

1: 9.6	↓	6: 8.7	↖	Serie	87
2: 9.9	↗	7: 8.7	↓		
3: 10.7x	↘	8: 10.2	→	Total	170
4: 8.7	↘	9: 8.6	↗		
5: 8.6	↗	10: 9.5	↖		

1: 9.0	↓	Serie	43
2: 8.9	←		
3: 9.8	←	Total	213
4: 9.6	↓		
5: 8.7	←		

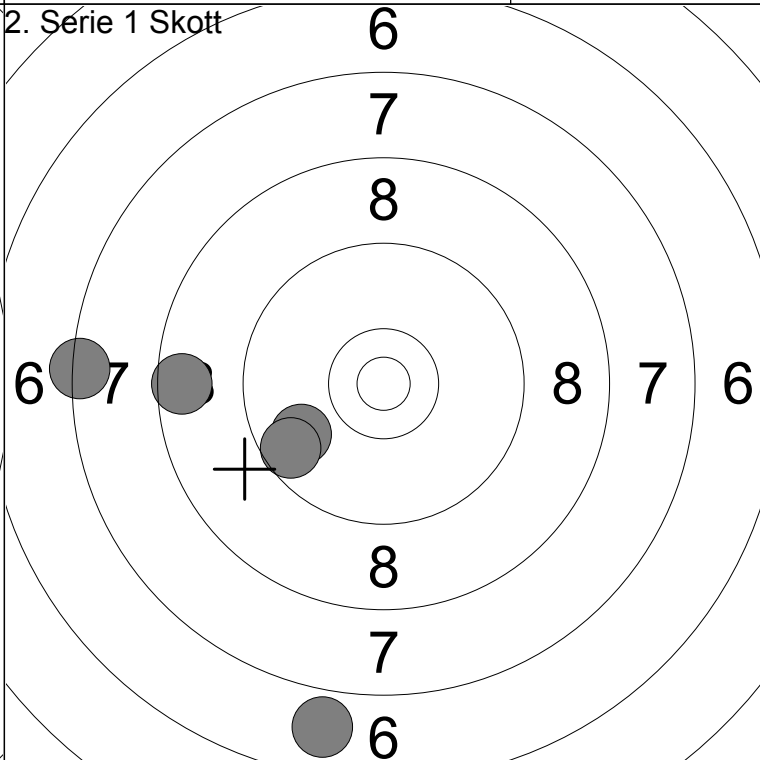
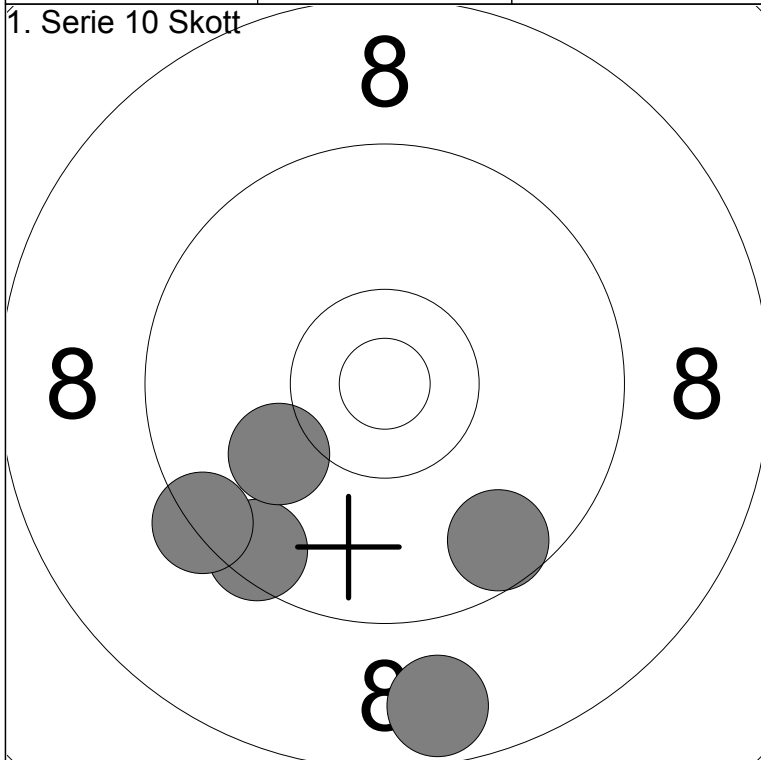

6: 9.5	↘	Serie	45
7: 9.6	↘		
8: 9.4	↘	Total	258
9: 8.7	↓		
10: 10.1	↖		

1: 9.8	↖	Serie	39
2: 8.6	←		
3: 9.6	↖	Total	297
4: 6.9	↓		
5: 7.4	←		



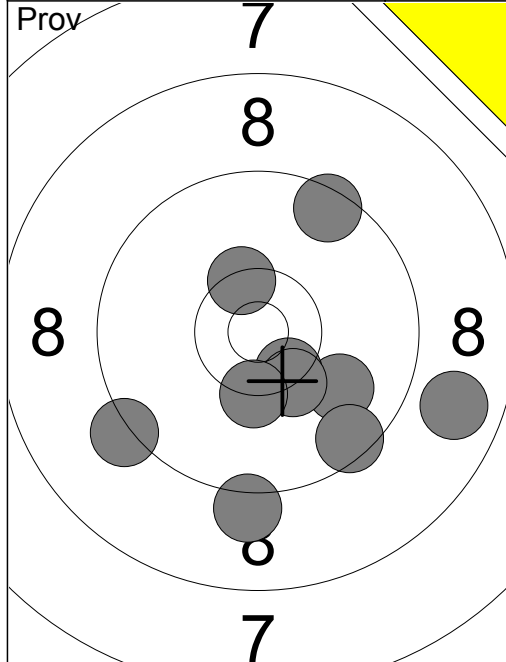

1:	9.1	↓
2:	9.9	↘
3:	9.5	↘
4:	9.2	↙
5:	8.8	→
6:	9.5	↗
7:	10.4x	↘
8:	10.3x	↘
9:	10.3x	↓
10:	10.4x	↗

Serie	93
Total	182

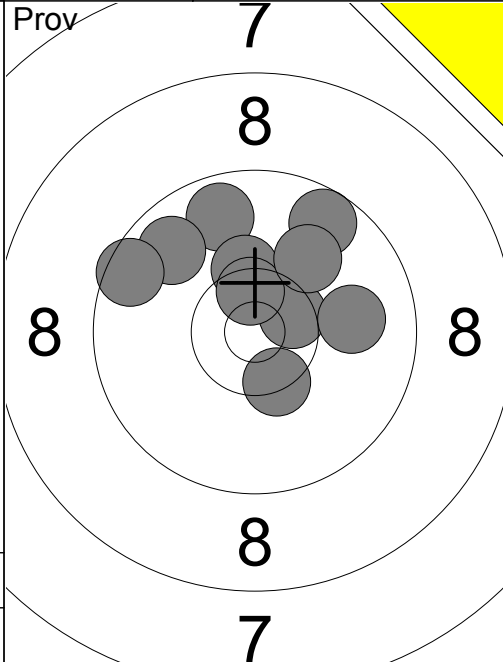

11:	9.7	↗
12:	9.8	↖
13:	9.6	↗
14:	10.3x	↗
15:	10.5x	↗
16:	10.5x	↗
17:	10.0	→
18:	10.4x	↘
19:	10.0	↗
20:	9.5	↖

Serie	96
Total	182

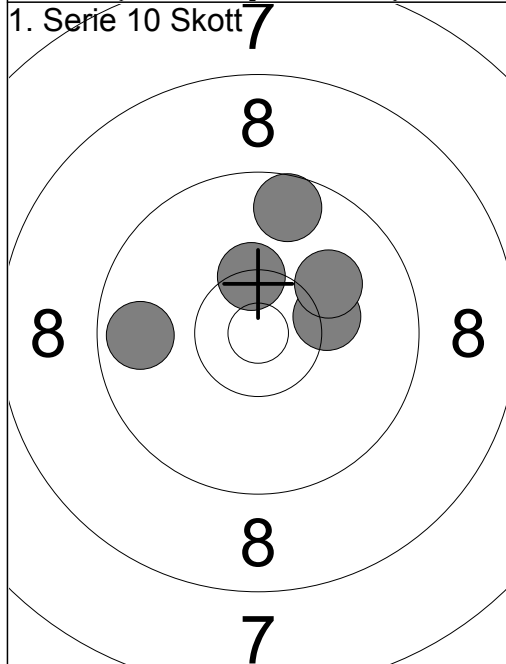

1:	9.7	←
2:	10.2	→
3:	9.6	↗
4:	10.4x	↗
5:	10.1	↗

Serie	48
Total	230

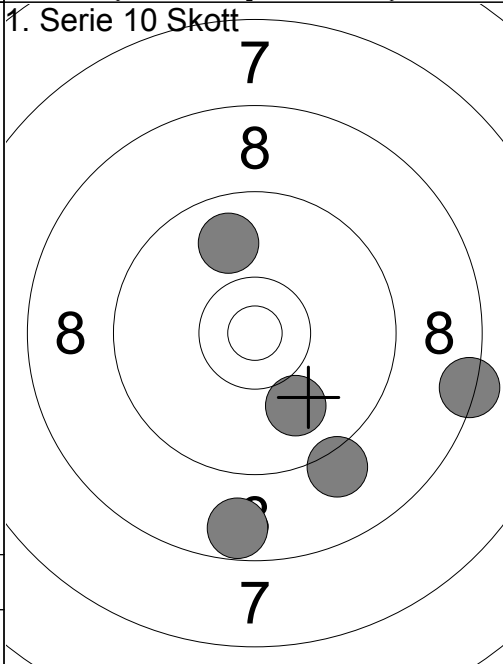

6:	10.0	↘
7:	8.4	→
8:	8.7	↘
9:	9.1	↘
10:	9.9	↗

Serie	44
Total	274

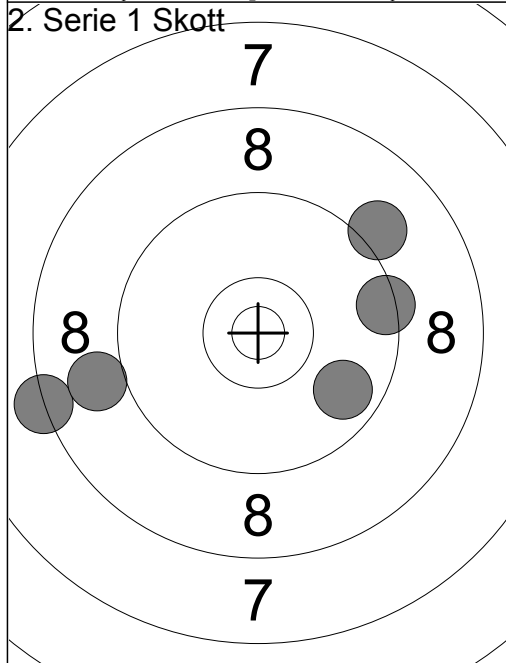

1:	8.3	←
2:	9.4	→
3:	9.0	←
4:	9.1	↗
5:	9.7	↘

Serie	44
Total	318

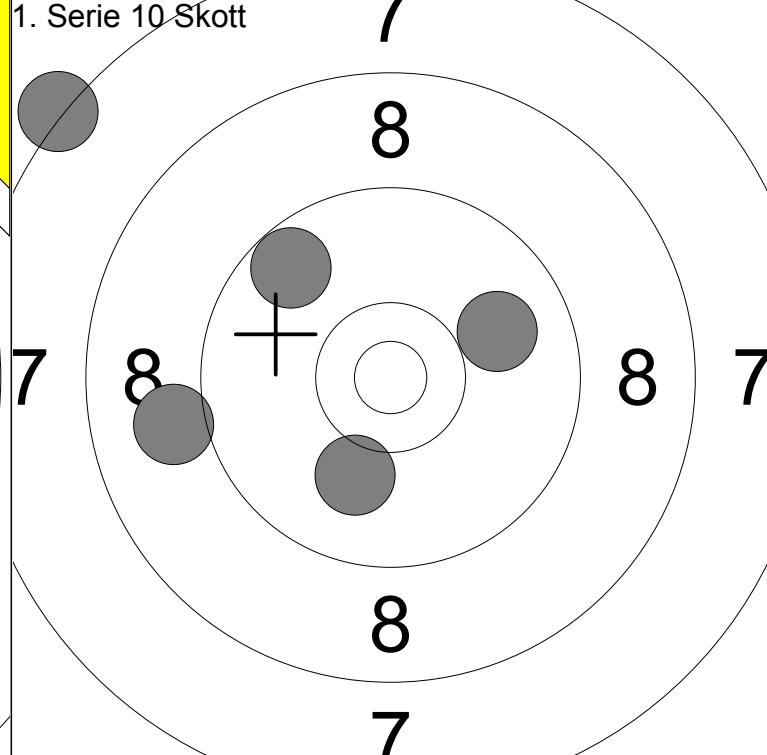
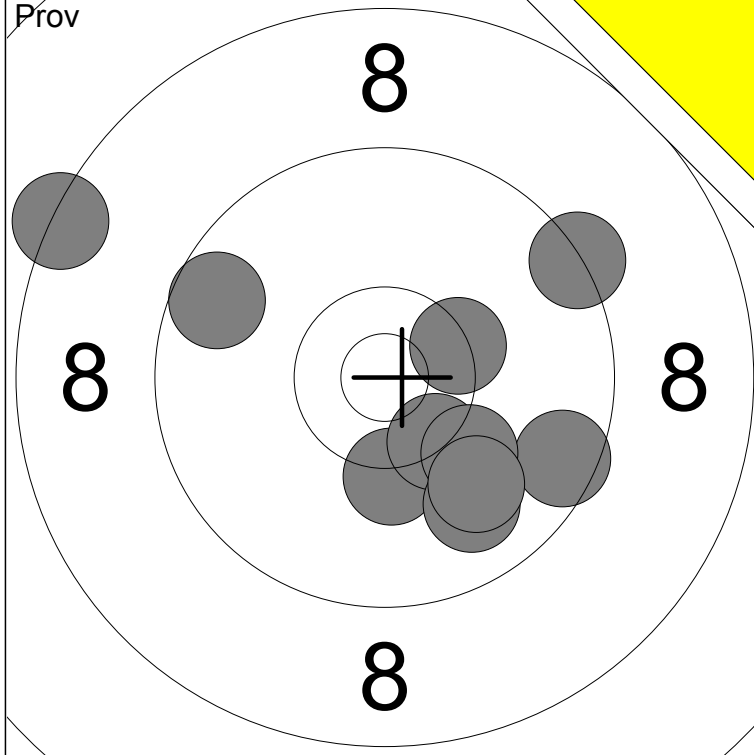

1: 9.6 →	6: 8.4 ↖	Serie	93
2: 9.3 ↗	7: 10.4x ↘		
3: 9.6 ↖	8: 10.1 ↘	Total	169
4: 10.4x →	9: 9.8 ↘		
5: 10.2 ↓	10: 9.9 ↘		

1: 7.2 ↖	Serie	44
2: 9.9 →		
3: 9.7 ↗	Total	213
4: 9.0 ←		
5: 10.0 ↓		

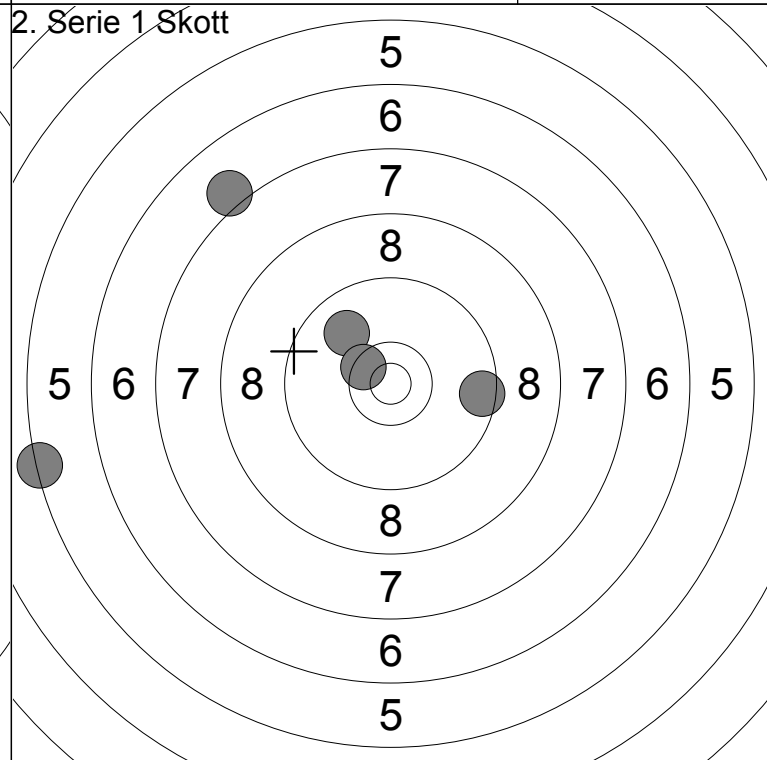
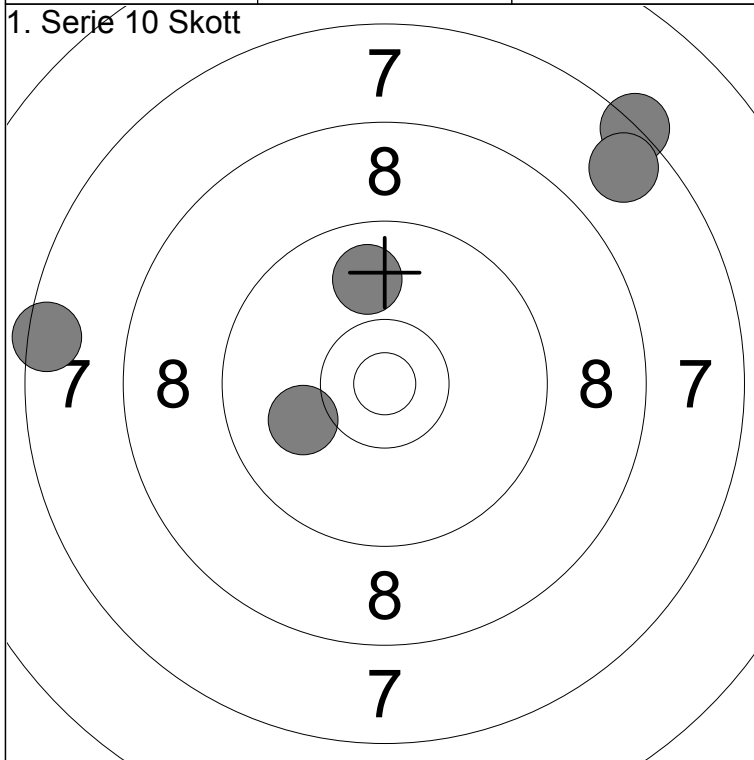

6: 7.3 ↗	Serie	40
7: 7.5 ←		
8: 7.7 ↗	Total	253
9: 9.9 ↑		
10: 10.0 ←		

1: 7.1 ↗	Serie	40
2: 5.4 ←		
3: 9.9 ↗	Total	293
4: 10.5x ↗		
5: 9.5 →		

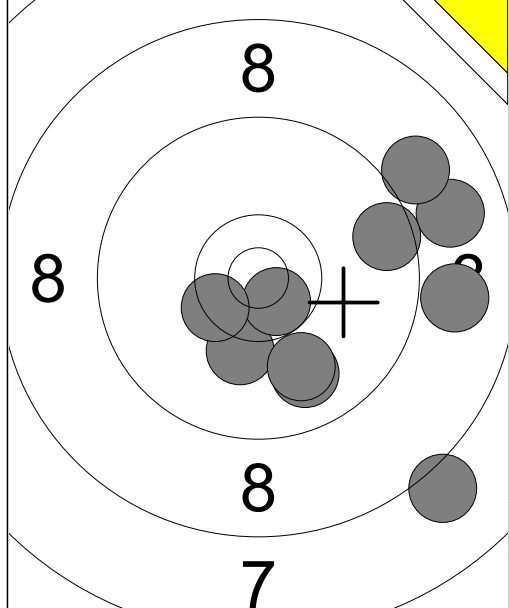

1:	10.2	↓
2:	8.9	→
3:	9.9	↓
4:	10.6x	↓
5:	8.1	↓
6:	9.9	↓
7:	8.9	→
8:	9.6	→
9:	9.0	↗
10:	10.4x	↙
Serie		90
Total		167

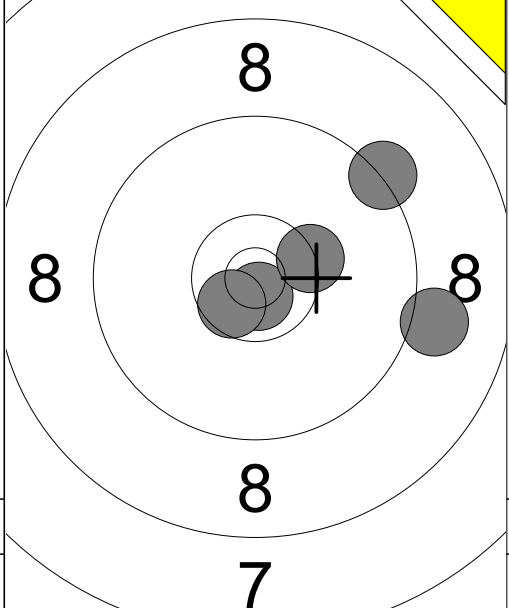

11:	10.8x	↓
12:	9.3	↗
13:	10.6x	↙
14:	9.1	→
15:	10.4x	→
Serie		48
Total		167

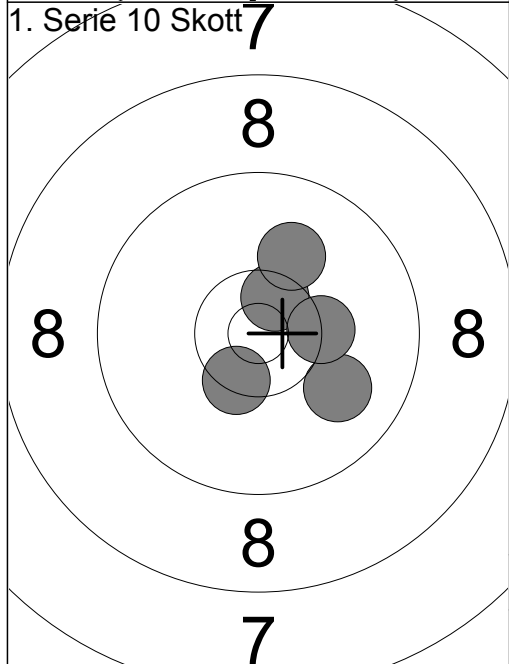

1:	10.4x	↓
2:	10.0	→
3:	10.5x	↗
4:	10.1	↗
5:	10.3x	→
Serie		50
Total		217

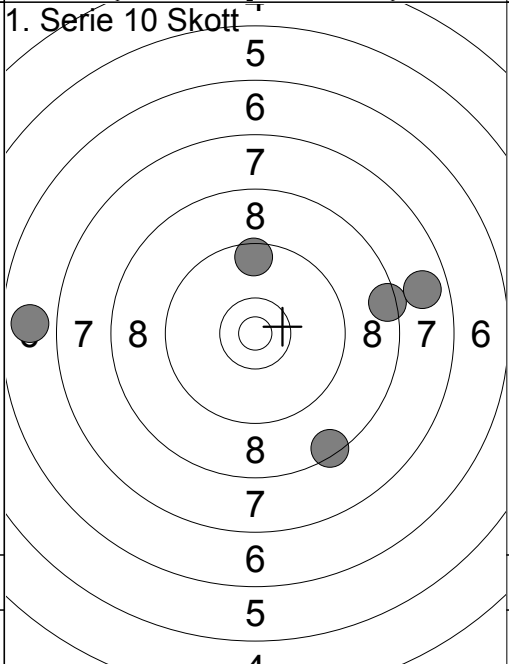

6:	8.4	↓
7:	8.5	→
8:	7.8	→
9:	6.8	←
10:	9.6	↑
Serie		38
Total		255

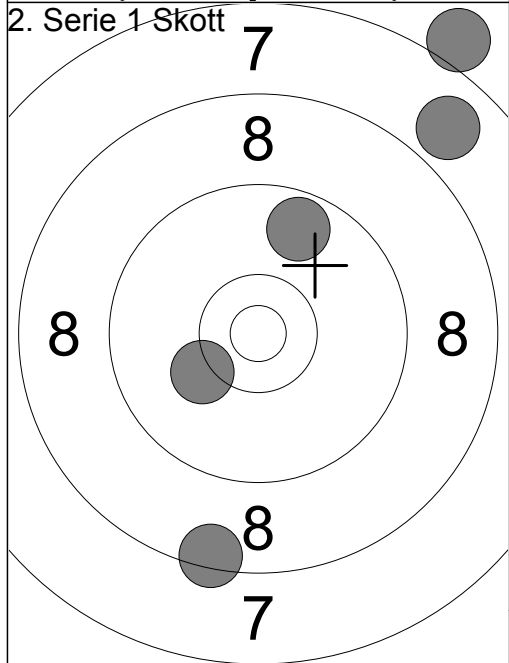

1:	7.9	↗
2:	7.0	↗
3:	8.4	↓
4:	9.7	↗
5:	10.2	↙
Serie		41
Total		296

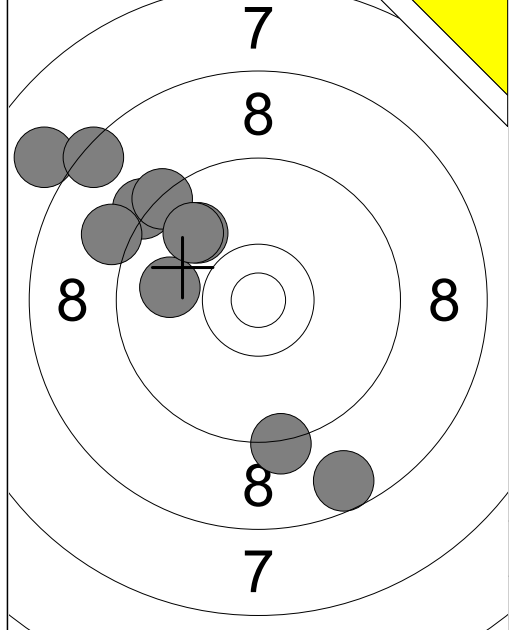

1:	9.9	↗
2:	9.3	↓
3:	8.6	↓
4:	8.0	↗
5:	9.2	↗
6:	9.9	←
7:	9.1	↗
8:	9.3	↗
9:	8.4	↗
10:	9.9	↗
Serie		87
Total		156

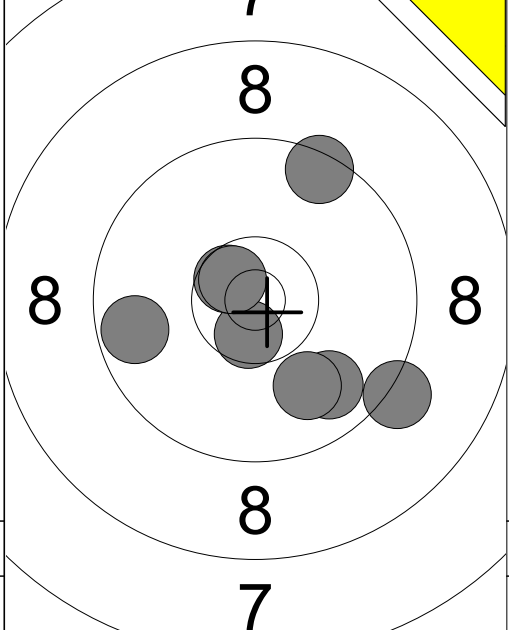

11:	10.6x	↓
12:	10.6x	↖
13:	9.2	↘
14:	9.8	↘
15:	9.7	←
16:	9.9	↓
17:	10.6x	↗
18:	9.5	↗
Serie		75
Total		156

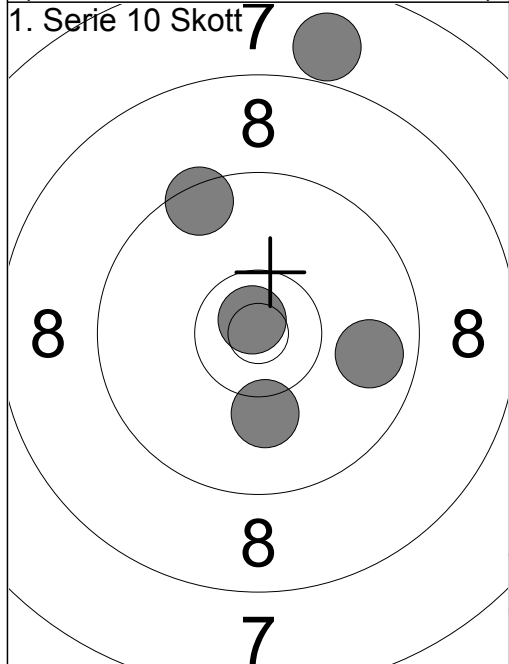

1:	9.5	↗
2:	10.1	↓
3:	7.9	↗
4:	10.8x	↗
5:	9.8	→
Serie		45
Total		201

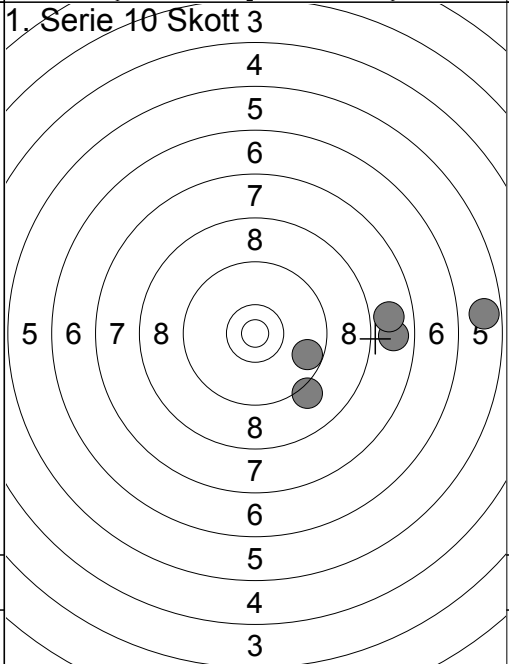

6:	7.8	→
7:	5.7	→
8:	9.7	↘
9:	9.1	↓
10:	7.9	→
Serie		37
Total		238

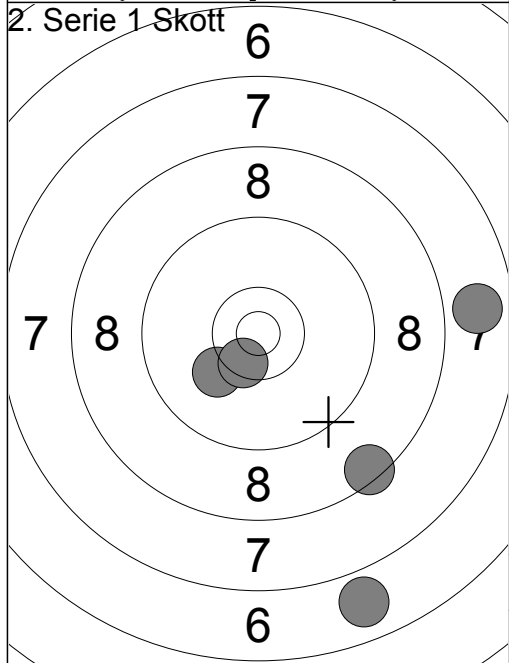

1:	6.9	↓
2:	10.2	↖
3:	10.5x	↓
4:	7.8	→
5:	8.5	↓
Serie		41
Total		279

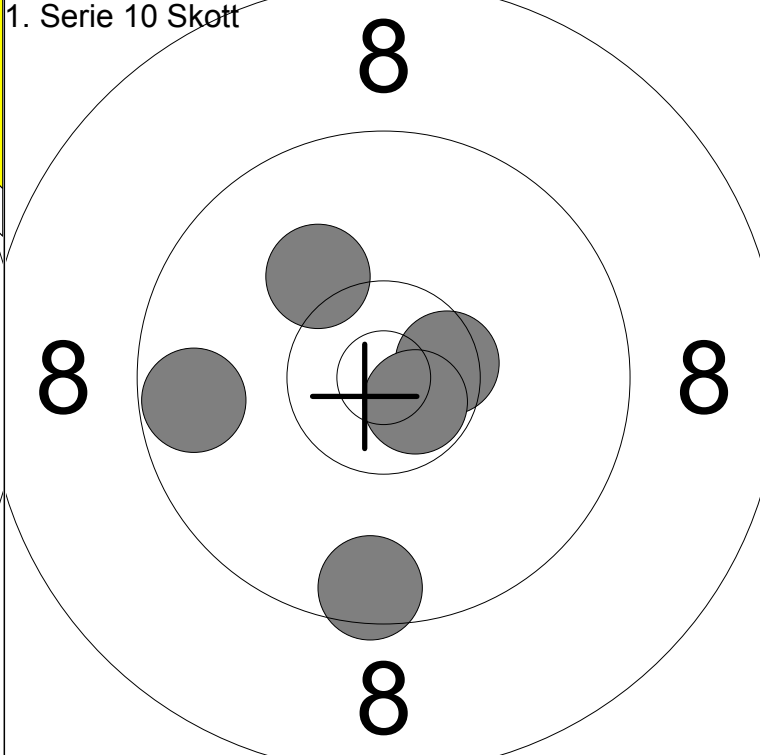
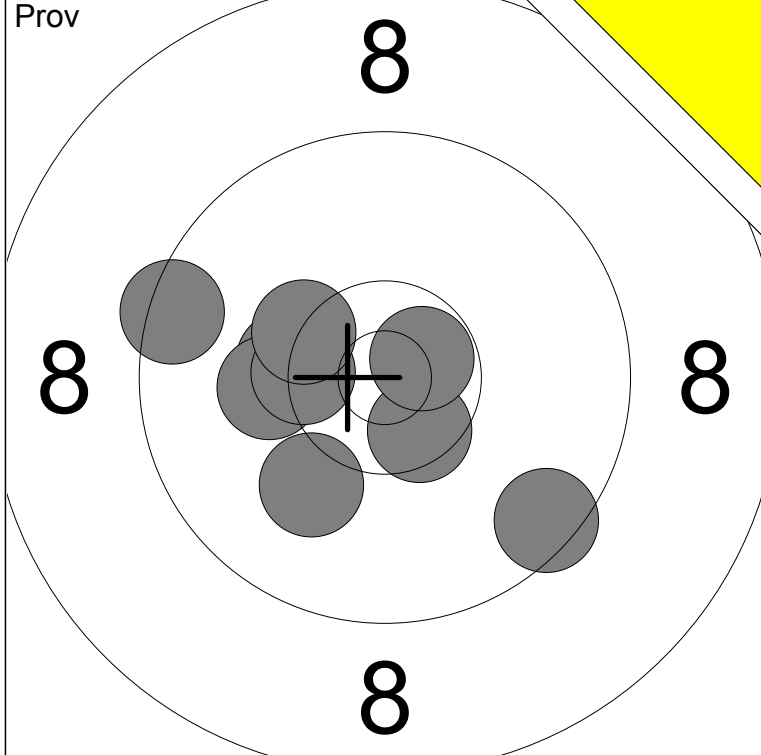

1: 10.3x ←	6: 9.5 ←	Serie	88
2: 10.1 ↘	7: 10.4x ←		
3: 9.5 ↘	8: 10.3x ↗	Total	189
4: 10.5x ↘	9: 10.7x ↗		
5: 10.2 ←			

1: 10.5x →	Serie	48
2: 10.7x ↘		
3: 10.1 ↗	Total	237
4: 9.5 ↓		
5: 9.7 ←		

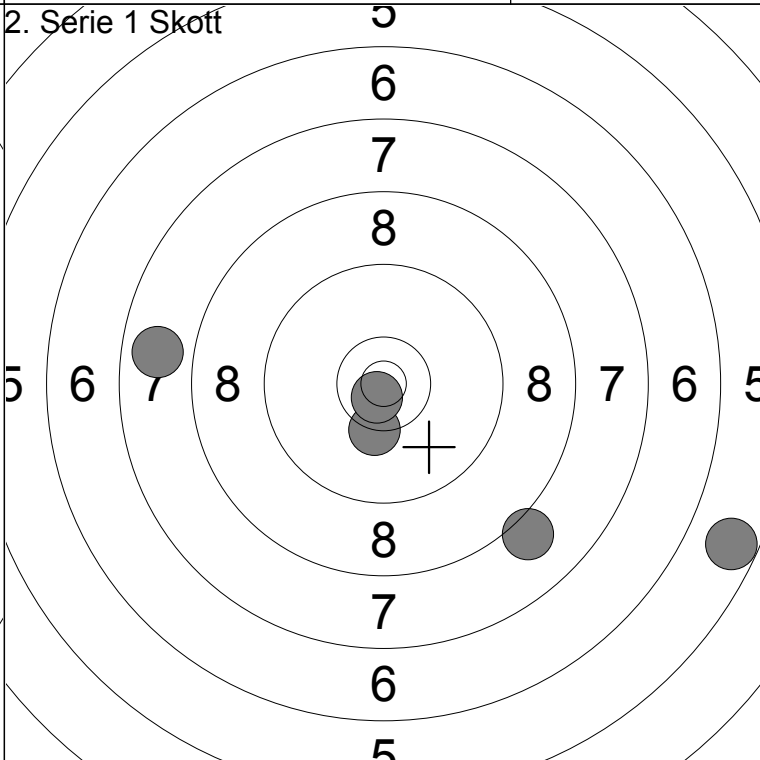
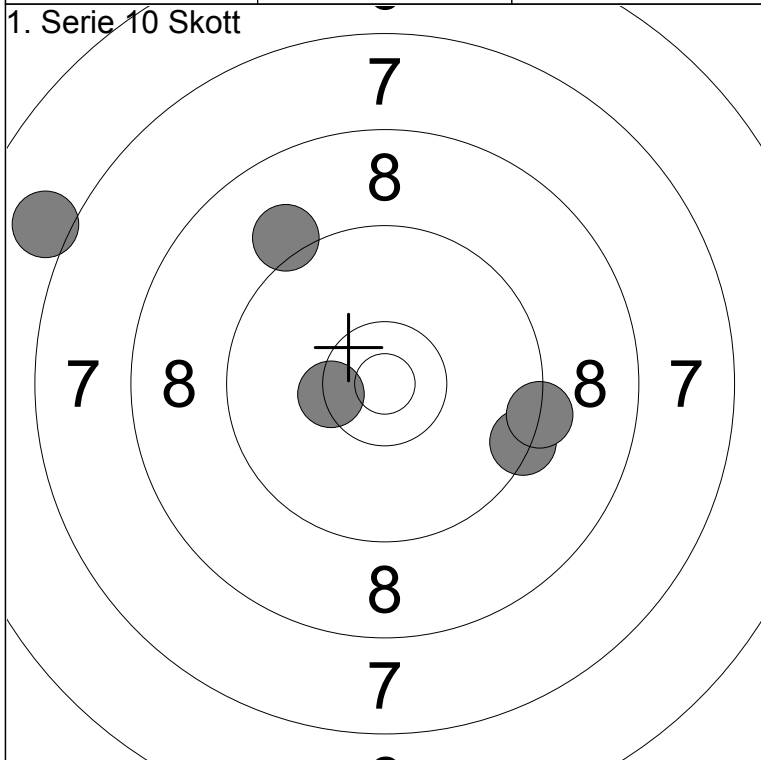

6: 9.4 ↘	Serie	44
7: 9.3 ↘		
8: 7.0 ↗	Total	281
9: 9.1 ↗		
10: 10.4x ←		

1: 5.7 →	Serie	40
2: 10.3x ↓		
3: 7.8 ←	Total	321
4: 10.7x ↘		
5: 8.1 ↘		

Skjutlag  
**4**

Tavla  
**6**

# Niklas Johansson

Ramselefors

Ramselefors

Sen-S

Vb

20.08.2017

Förbundsmästerskap 2017

Ramselefors SKF

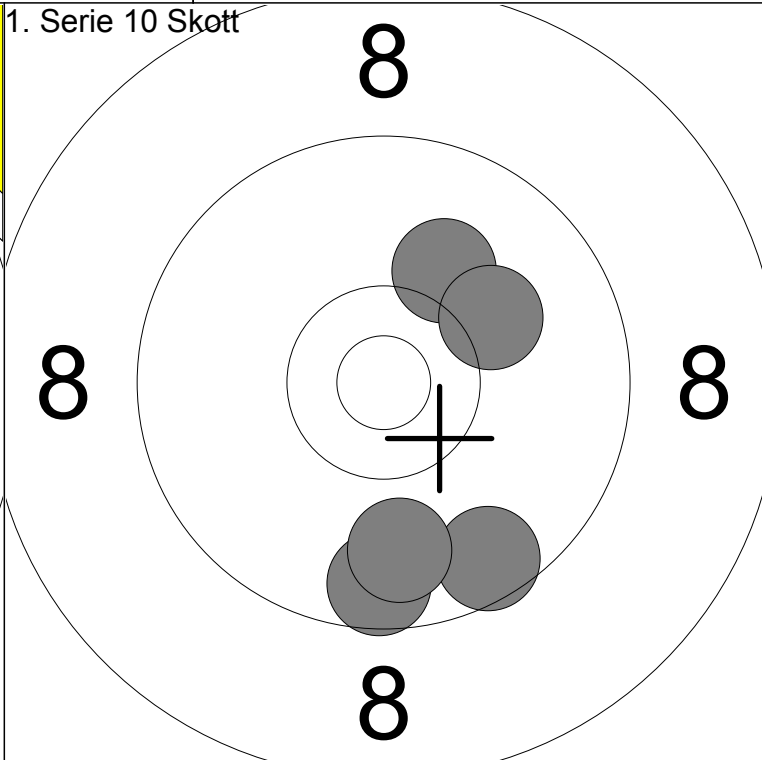
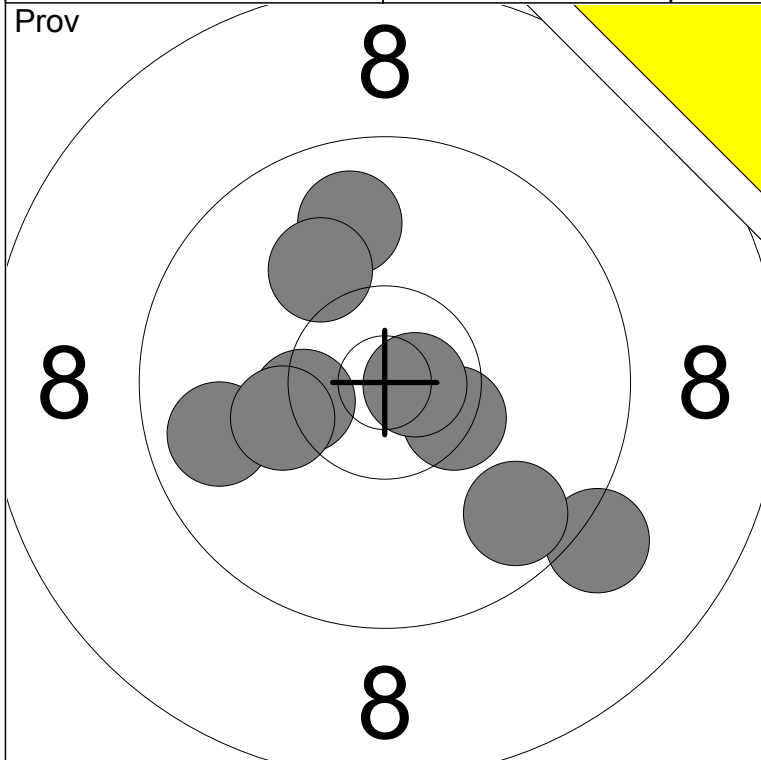

1: 9.8	←	6: 10.1	↗	Serie	86
2: 9.2	↘	7: 9.7	↘		
3: 9.9	↑	8: 10.2	←	Total	186
4: 10.4x	↘	9: 10.7x	→		
5: 10.4x	←				

1: 9.6	↘	Serie	47
2: 9.6	↘		
3: 10.1	↗	Total	233
4: 9.8	↘		
5: 10.1	↗		

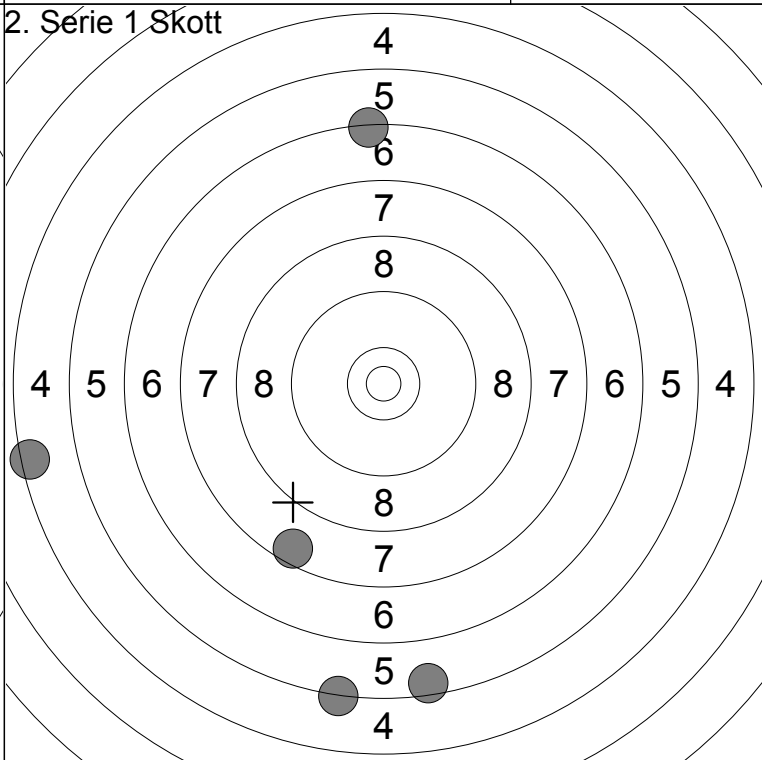
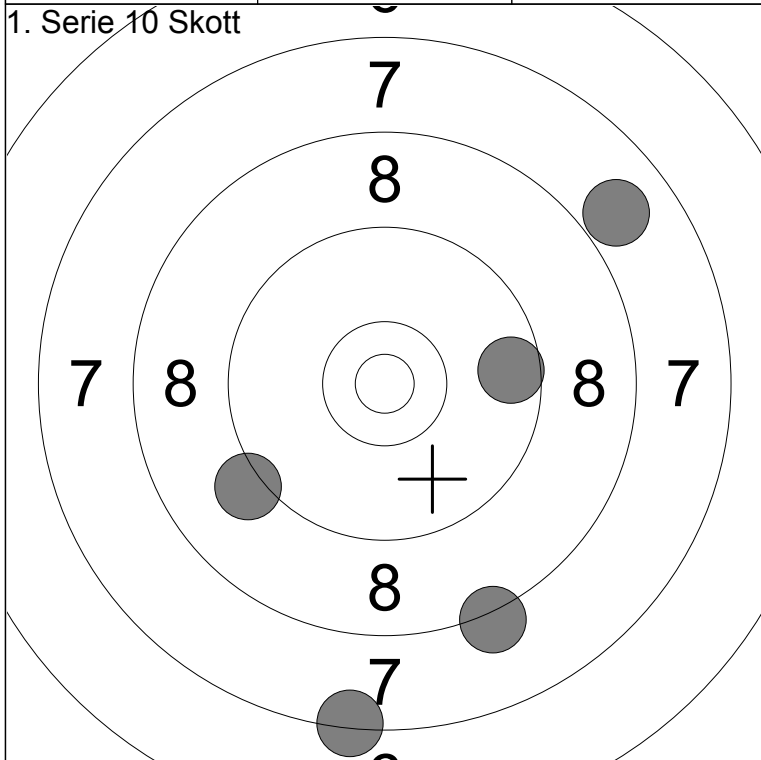

6: 7.9	↗	Serie	40
7: 7.4	↘		
8: 9.6	→	Total	273
9: 9.1	←		
10: 8.2	↘		

1: 5.3	↘	Serie	27
2: 4.5	←		
3: 5.5	↘	Total	300
4: 6.3	↑		
5: 7.6	↘		

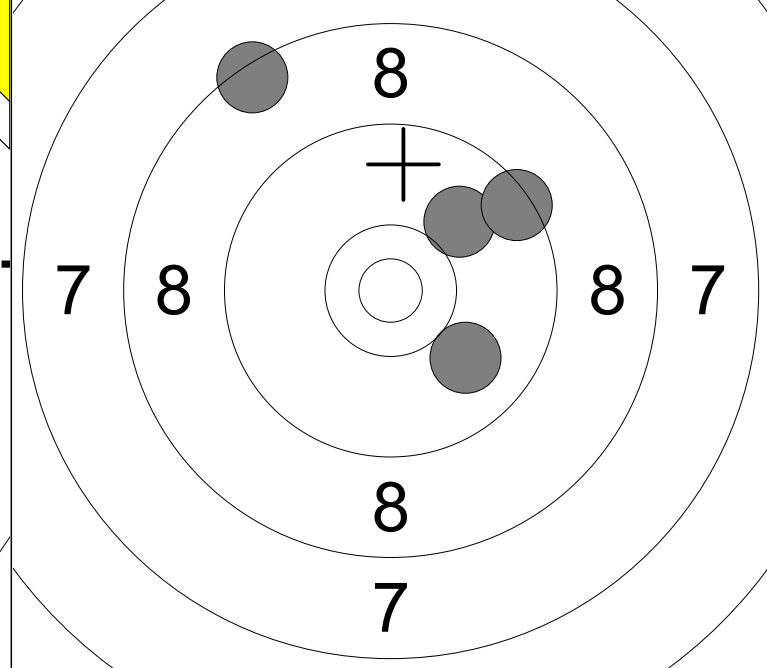
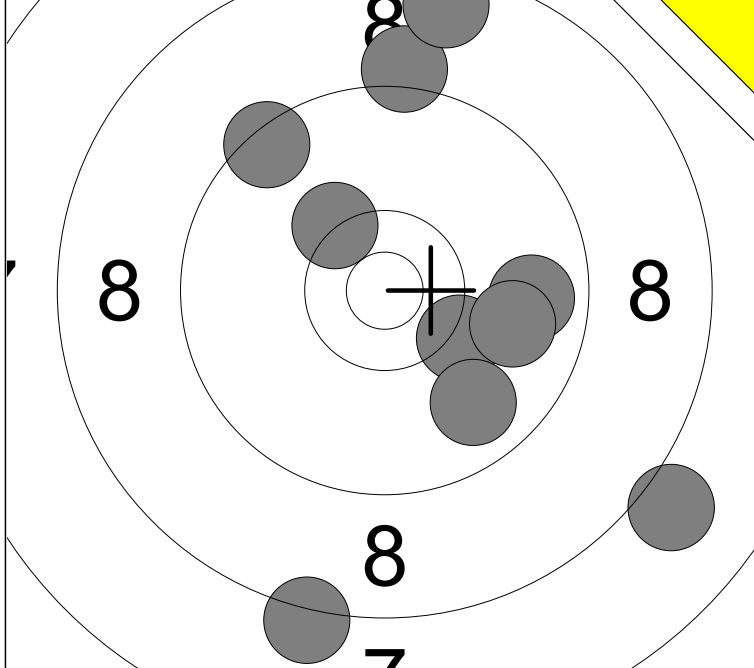

1: 9.8 →	6: 9.8 ↘	Serie	89
2: 8.2 ↓	7: 9.1 ↑		
3: 8.0 ↘	8: 10.3 ↗	Total	183
4: 10.2 ↓	9: 9.4 ↗		
5: 9.9 →	10: 8.6 ↑		

1: 9.9 ↘	Serie	43
2: 7.6 ↑		
3: 8.4 ↗	Total	226
4: 10.0 ↗		
5: 9.4 ↗		

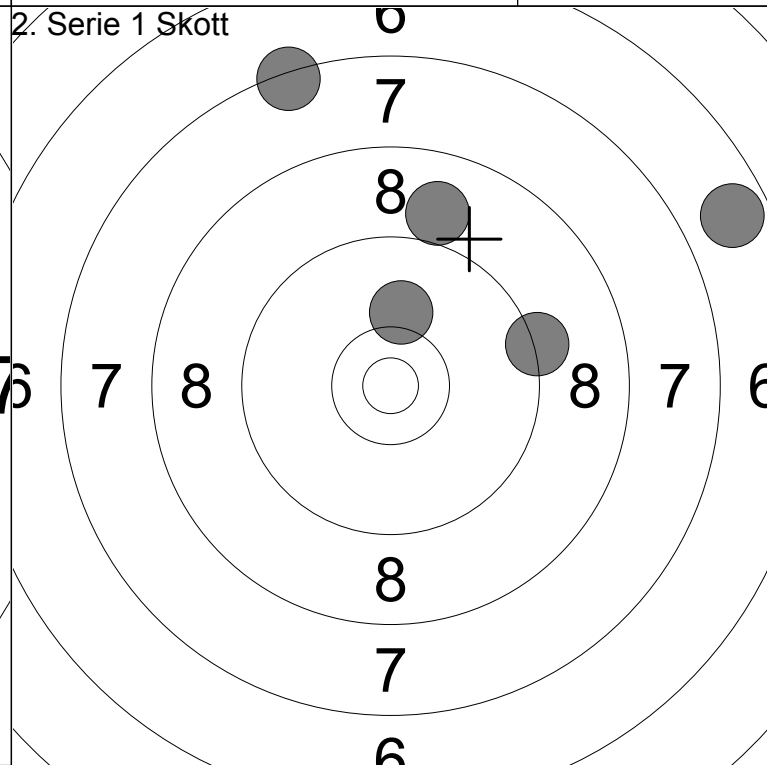
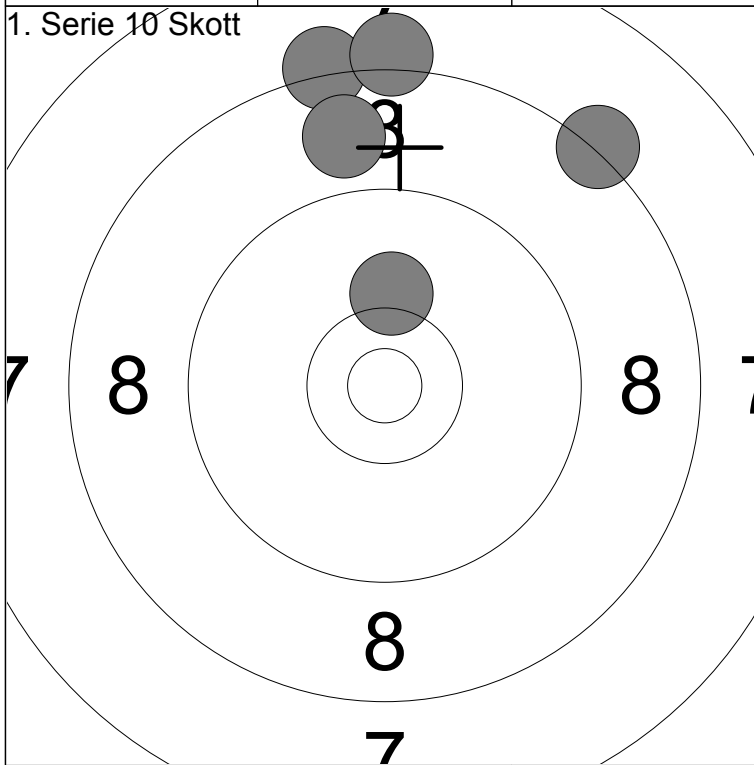

6: 8.2 ↑	Serie	42
7: 8.3 ↗		
8: 8.8 ↑	Total	268
9: 8.2 ↑		
10: 10.2 ↑		

1: 9.3 →	Serie	41
2: 9.0 ↑		
3: 6.7 ↗	Total	309
4: 10.1 ↑		
5: 7.4 ↑		

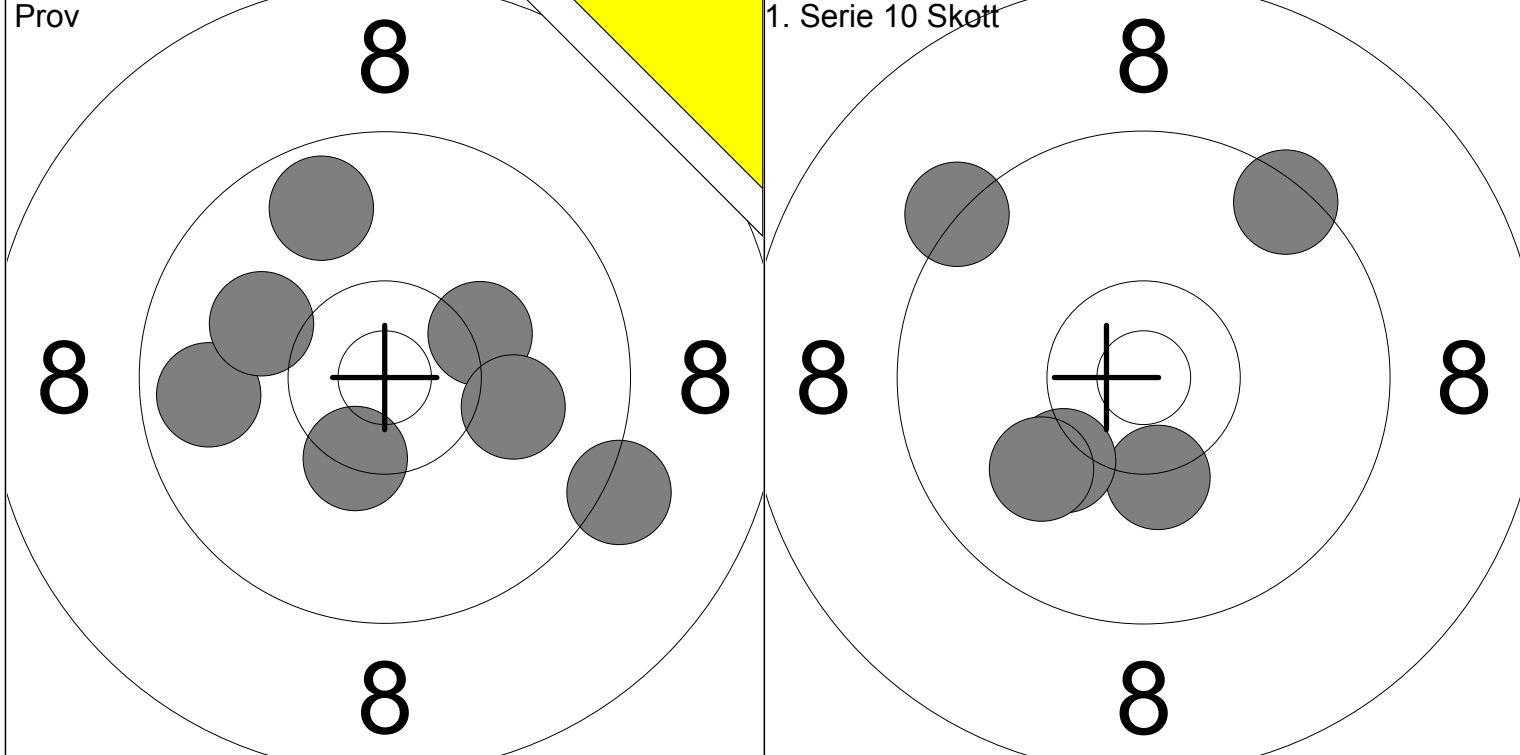

1: 10.2 →	6: 9.2 →			1: 10.3 ↓			
2: 9.8 ←	7: 9.7 ↗	Serie	67	2: 9.4 ↗		Serie	48
3: 10.4x ↓		Total	168	3: 9.3 ↗		Total	216
4: 10.0 ←				4: 10.2 ↓			
5: 10.1 →				5: 10.0 ↓			

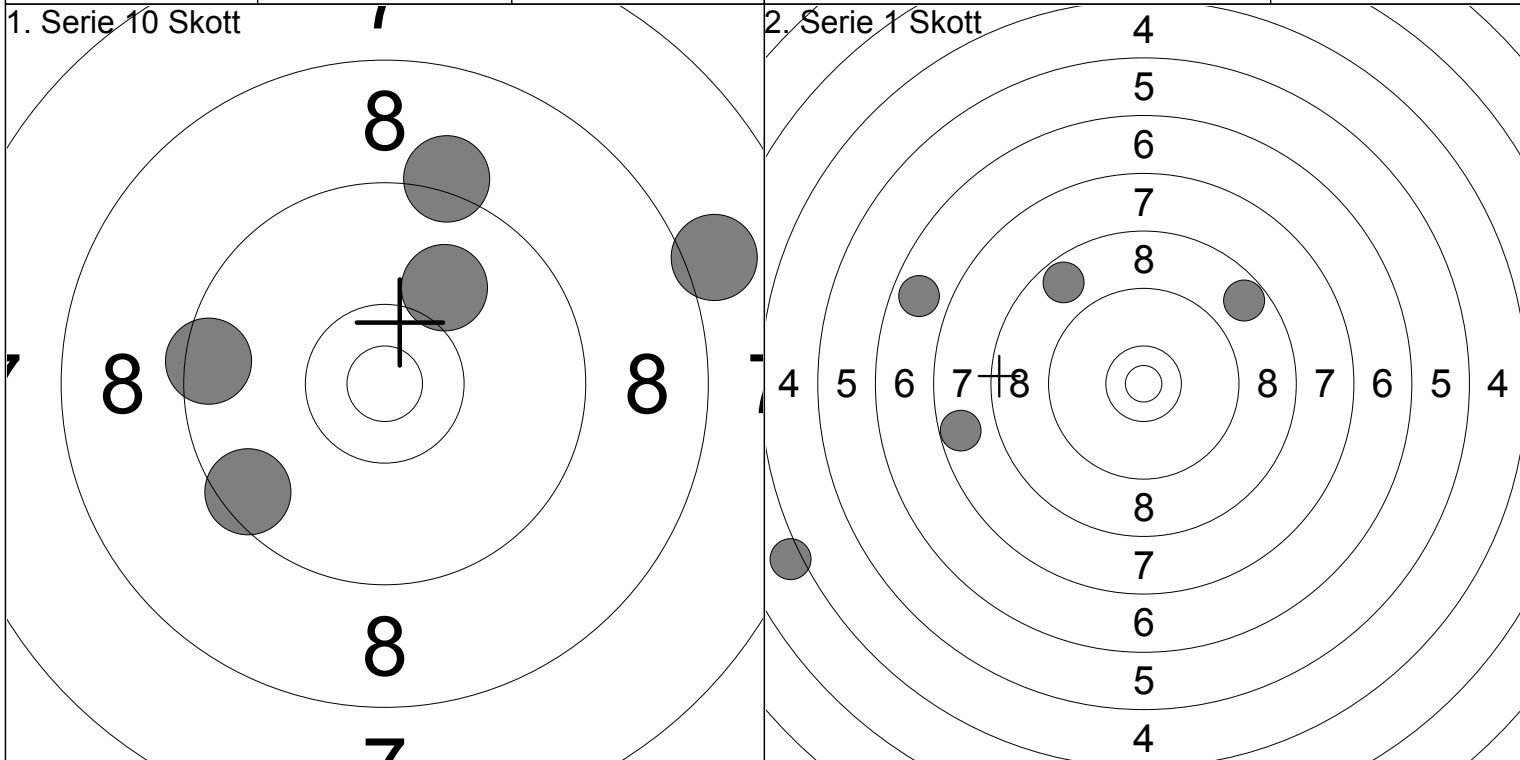

6: 10.0 ↗	1: 7.7 ←			2: 8.7 ↗			
7: 9.2 ↑		Serie	45	3: 6.8 ←		Serie	33
8: 9.5 ←		Total	261	4: 8.7 ↗		Total	294
9: 8.1 →				5: 4.1 ←			
10: 9.5 ←							



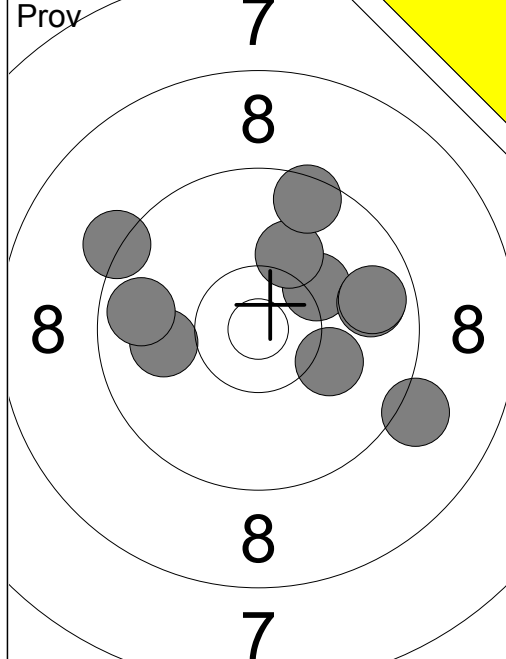

1:	10.0	←
2:	10.2	↗
3:	9.3	↖
4:	9.7	←
5:	9.8	→
6:	10.1	↗
7:	10.1	→
8:	9.5	↗
9:	9.7	→
10:	9.1	↘

Serie	94
Total	164

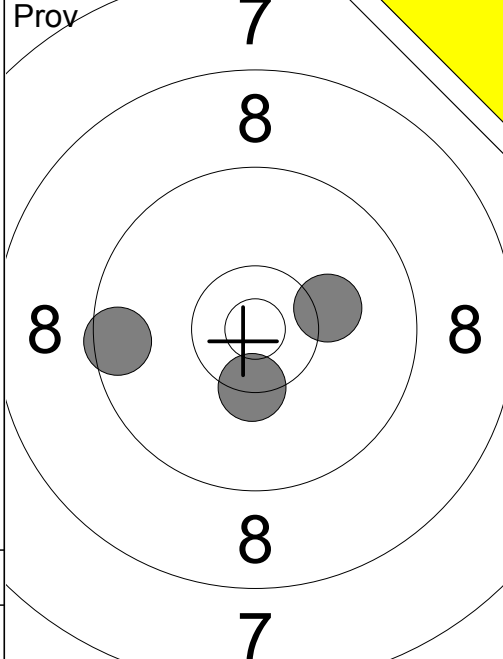

11:	10.2	→
12:	10.4x	↓
13:	9.5	←

Serie	29
Total	164

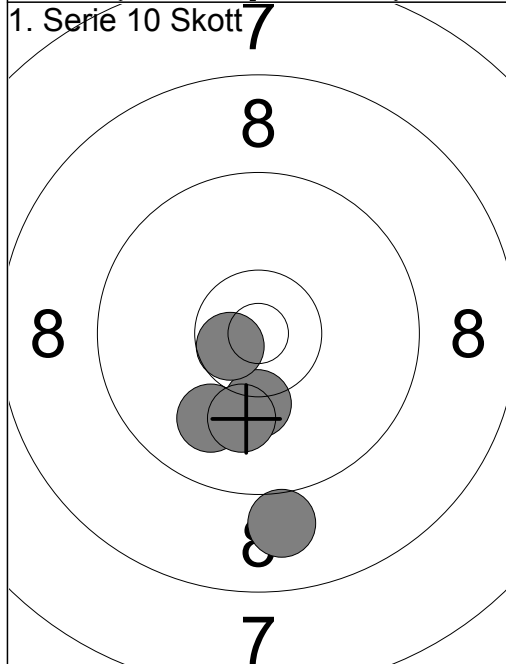

1:	10.2	↓
2:	10.6x	←
3:	9.0	↓
4:	10.0	↘
5:	10.1	↓

Serie	49
Total	213

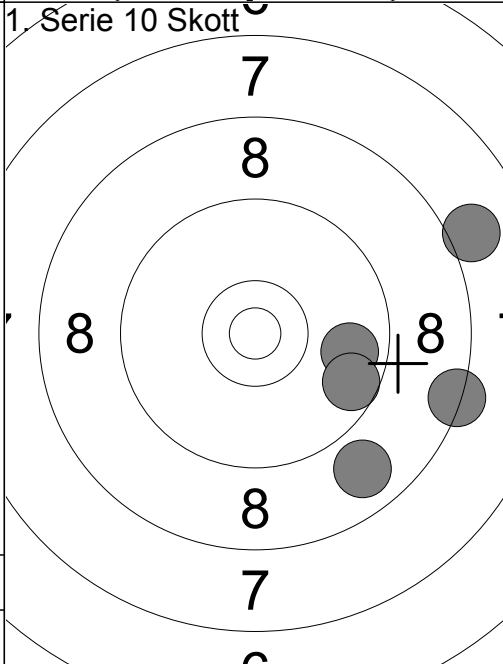

6:	8.0	↗
7:	8.8	↘
8:	9.8	→
9:	8.4	→
10:	9.6	↘

Serie	42
Total	255

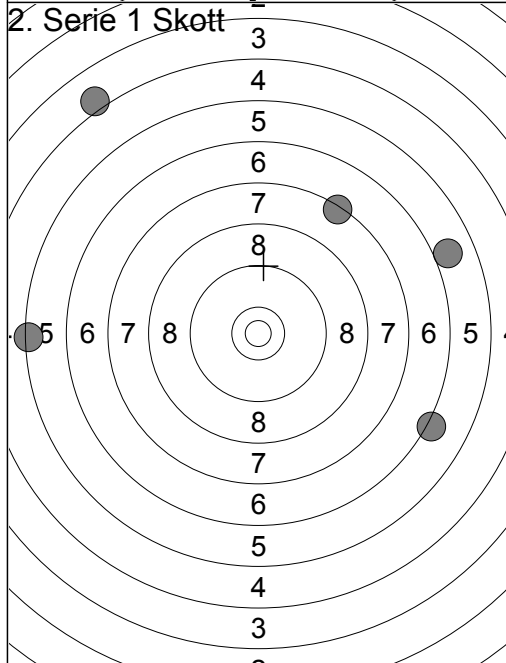

1:	7.4	↗
2:	4.1	↖
3:	6.2	↘
4:	6.0	→
5:	5.4	←

Serie	28
Total	283

Prov 	1: 8.6 ↙ 2: 10.4x ← 3: 9.3 ↗ 4: 9.2 ↗ 5: 10.5x ← 6: 10.5x ↓ 7: 9.6 ↗ 8: 10.5x ↗ 9: 9.8 ↗ 10: 10.4x ←	Prov 	11: 9.3 ↑ 12: 10.0 ↑ 13: 9.9 → 14: 9.3 ↓ 15: 9.9 →
Serie 94		Serie 46	
Total 160		Total 160	

1. Serie 10 Skott 	1: 9.2 → 2: 10.0 ↓ 3: 10.8x ↓ 4: 10.0 ↑ 5: 10.0 ↑	1. Serie 10 Skott 	6: 2.6 → 7: 10.6x ↑ 8: 8.2 ↗ 9: 9.7 ↓ 10: 9.3 →
Serie 49		Serie 38	
Total 209		Total 247	

2. Serie 1 Skott 	1: 10.1 ← 2: 7.4 → 3: 7.3 → 4: 9.3 ↓ 5: 9.5 →		
Serie 42			
Total 289			

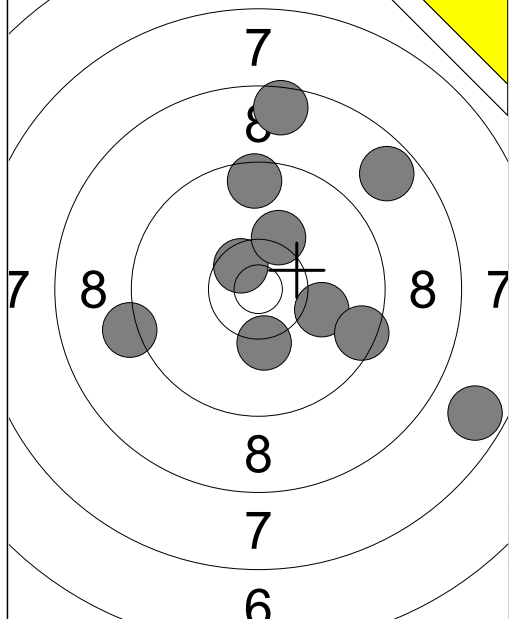

1:	7.7	↘
2:	10.2	↓
3:	10.1	→
4:	8.6	↑
5:	9.5	↑
6:	9.5	→
7:	9.2	←
8:	10.6x	↖
9:	8.7	↗
10:	10.2	↑
Serie		90
Total		159

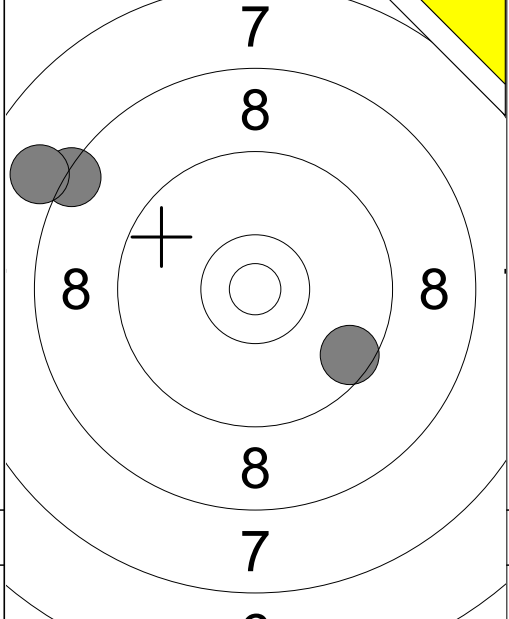

11:	9.6	↘
12:	8.4	↗
13:	8.0	↖
Serie		25
Total		159

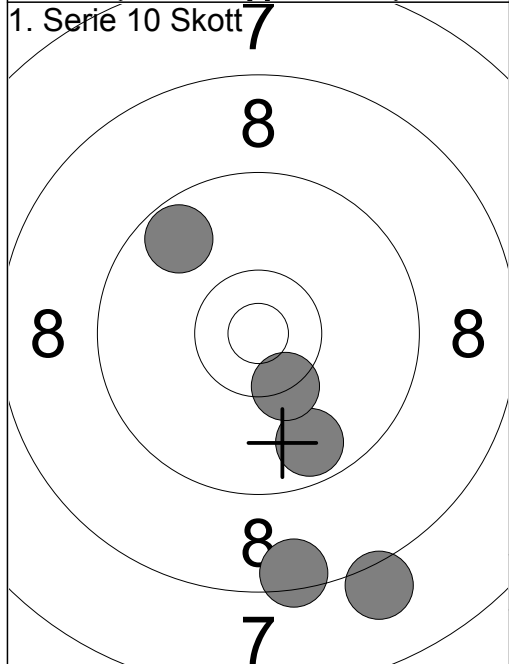

1:	8.1	↓
2:	9.7	↓
3:	8.5	↓
4:	10.3x	↓
5:	9.7	↗
Serie		44
Total		203

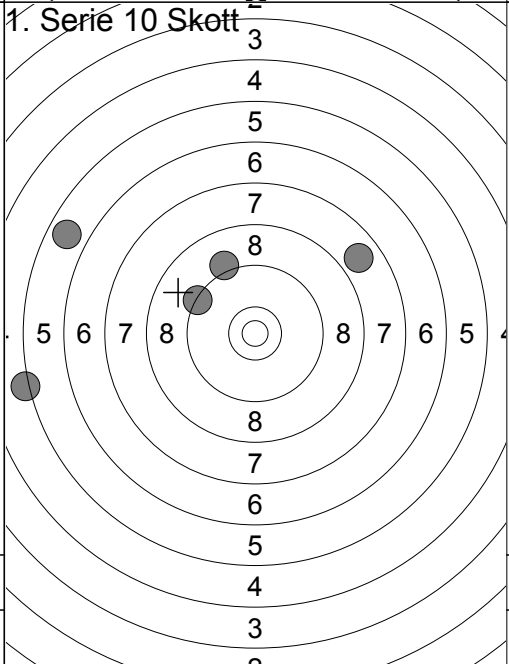

6:	5.8	↖
7:	5.2	←
8:	7.8	↗
9:	9.1	↑
10:	9.3	↖
Serie		35
Total		238

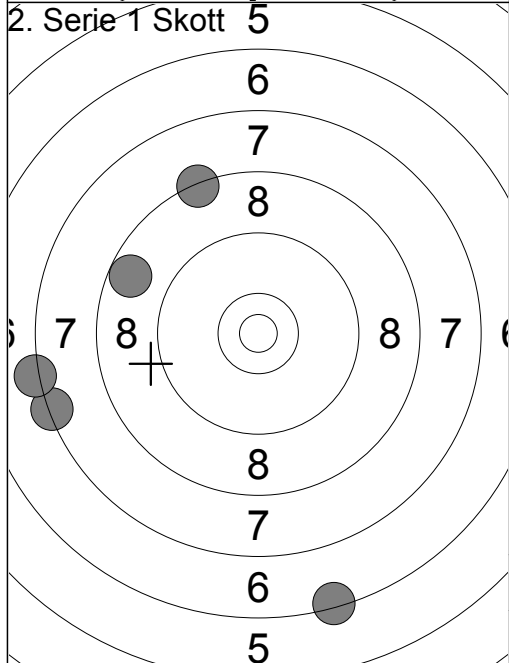

1:	6.4	↓
2:	8.3	↗
3:	7.4	←
4:	8.7	↖
5:	7.2	←
Serie		36
Total		274

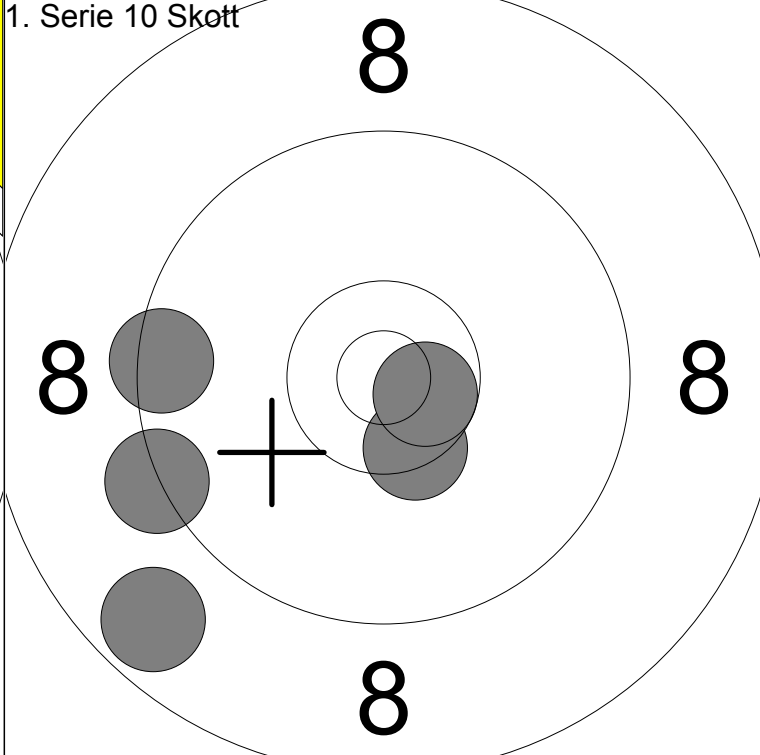
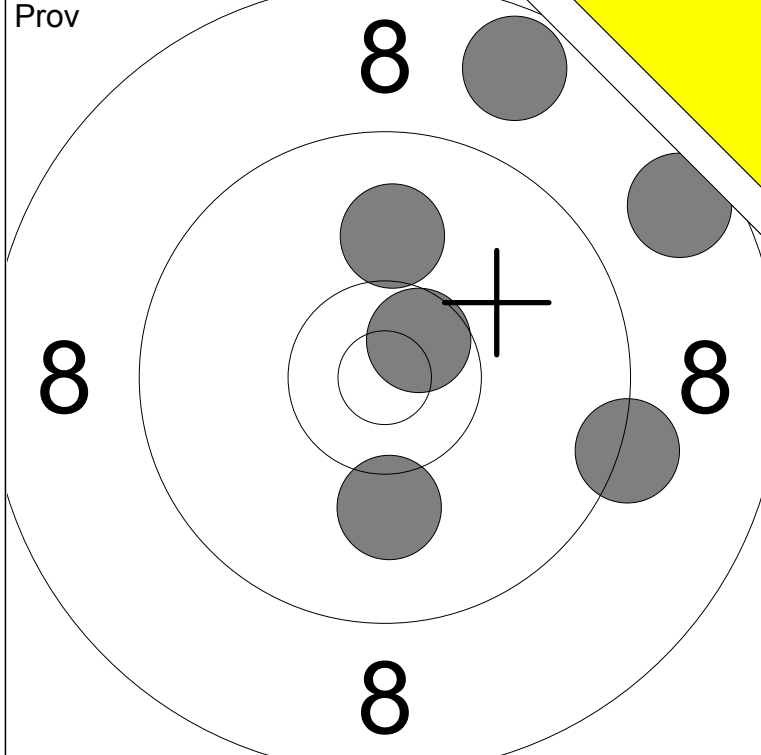

1: 9.2 →	6: 10.6x ↗				
2: 8.7 ↗		Serie	55		
3: 8.7 ↗					
4: 10.0 ↑		Total	165		
5: 10.1 ↓					

1: 10.4x ↓					
2: 10.7x →		Serie	46		
3: 8.7 ↘					
4: 9.3 ←		Total	211		
5: 9.5 ←					

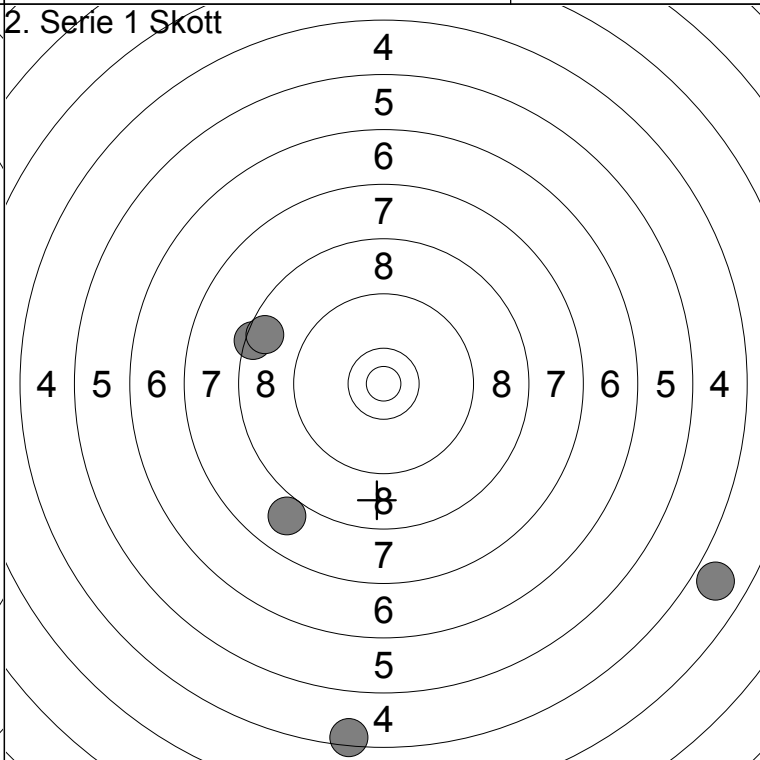
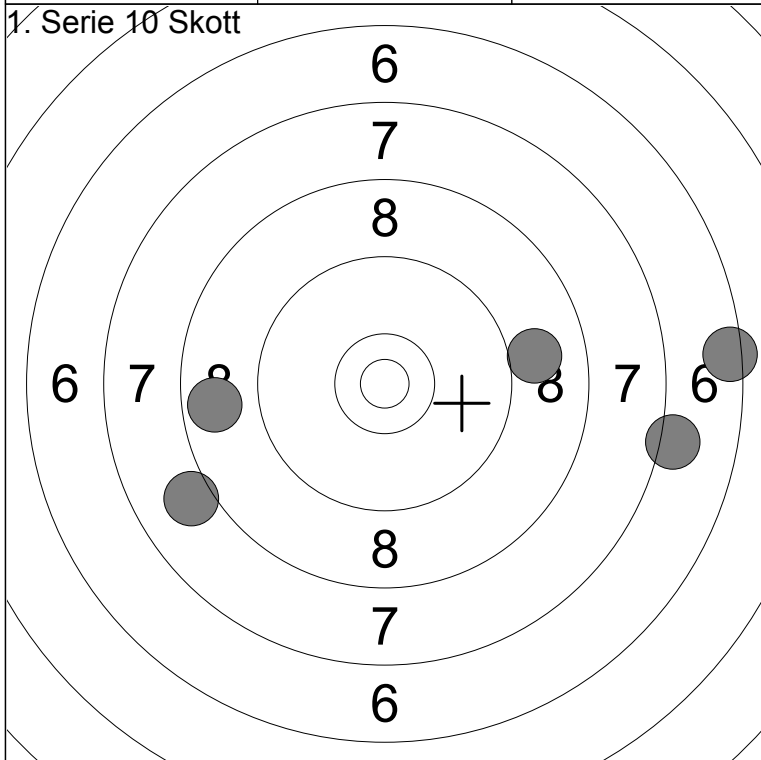

6: 8.0 ↙					
7: 6.5 →		Serie	38		
8: 9.0 →					
9: 8.7 ←		Total	249		
10: 7.1 →					

1: 8.4 ↙					
2: 4.4 ↓		Serie	31		
3: 3.9 →					
4: 8.0 ↘		Total	280		
5: 8.6 ↙					

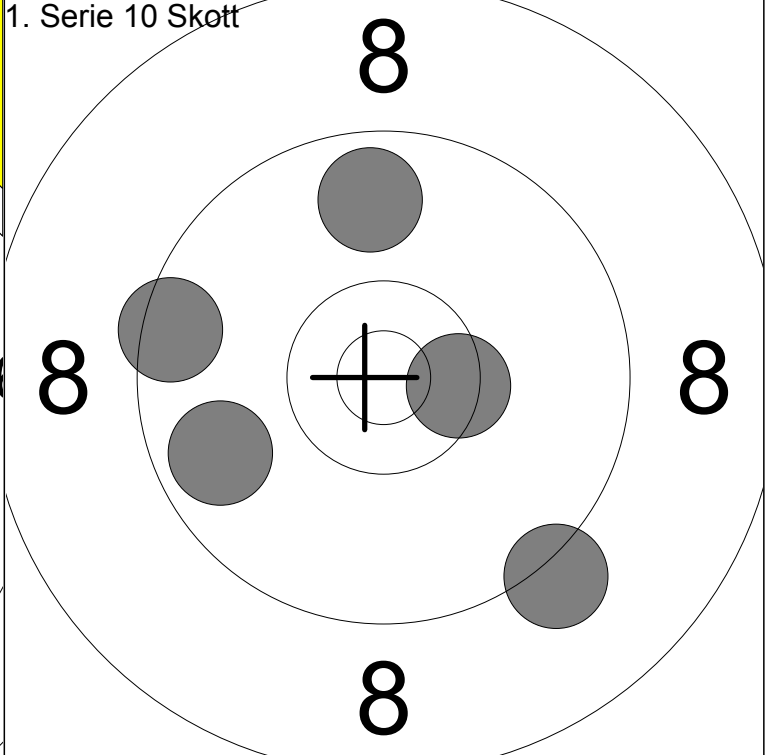
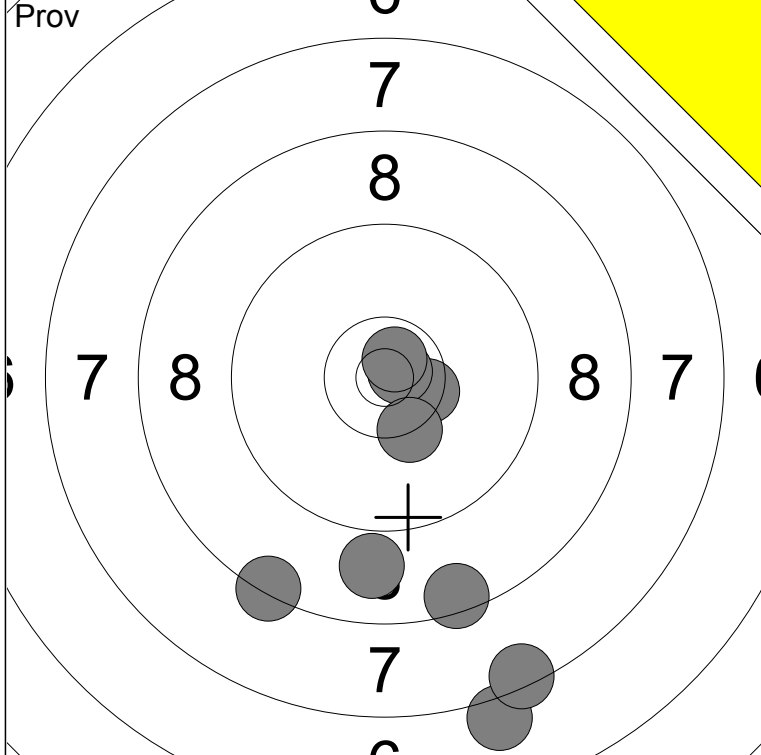

1: 8.9 ↓	6: 7.4 ↓	Serie	78
2: 7.1 ↓	7: 10.8x →		
3: 8.4 ↘	8: 10.3x ↓	Total	158
4: 10.5x →	9: 10.7x ↗		
5: 8.5 ↓			

1: 9.7 ↙	Serie	46
2: 9.2 ↓		
3: 9.8 ↑	Total	204
4: 10.4x →		
5: 9.5 ↖		

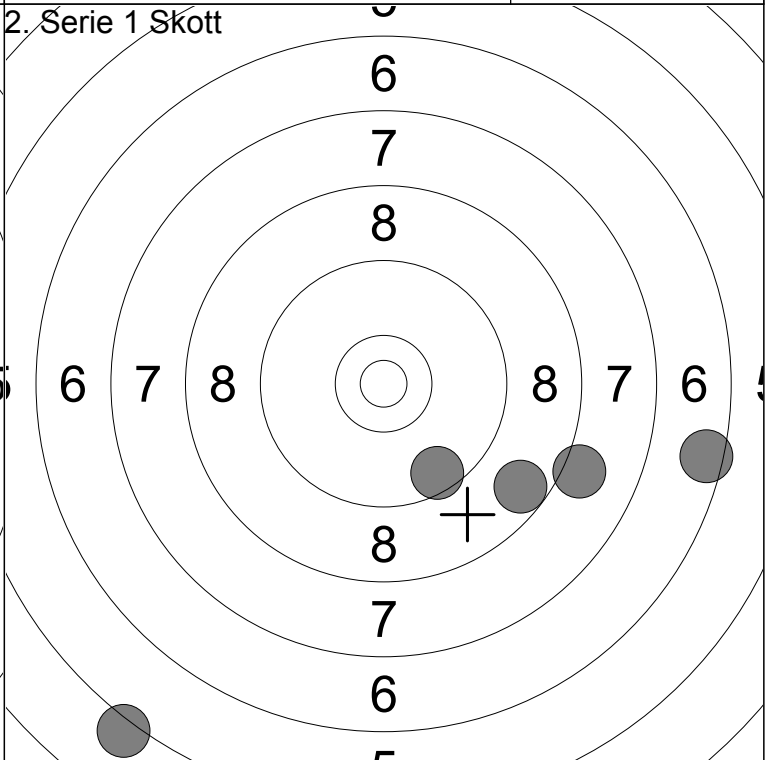
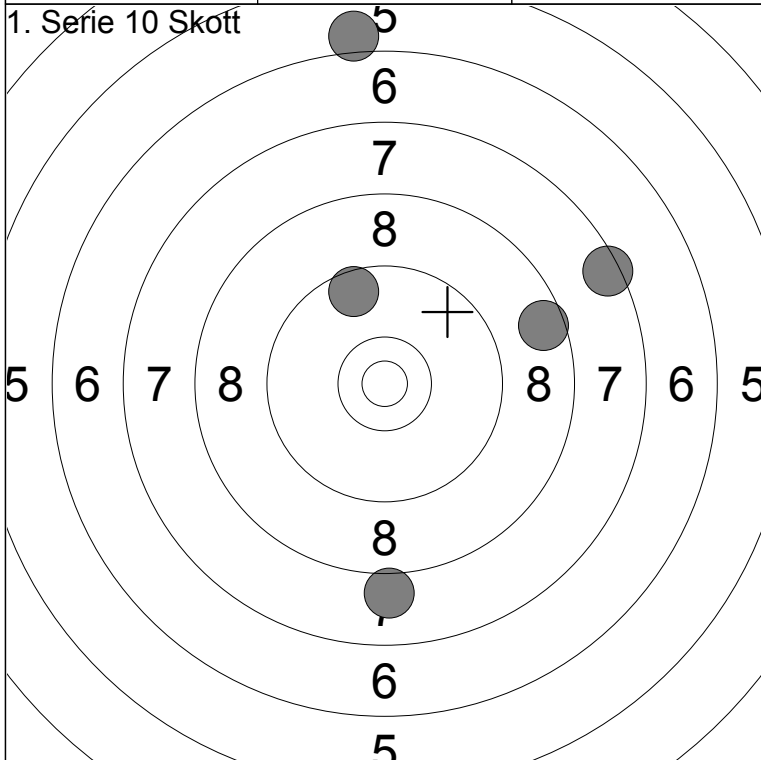

6: 8.6 →	Serie	38
7: 8.0 ↓		
8: 6.1 ↑	Total	242
9: 9.6 ↑		
10: 7.5 ↗		

1: 6.5 →	Serie	36
2: 8.7 ↓		
3: 8.1 →	Total	278
4: 5.2 ↙		
5: 9.6 ↓		

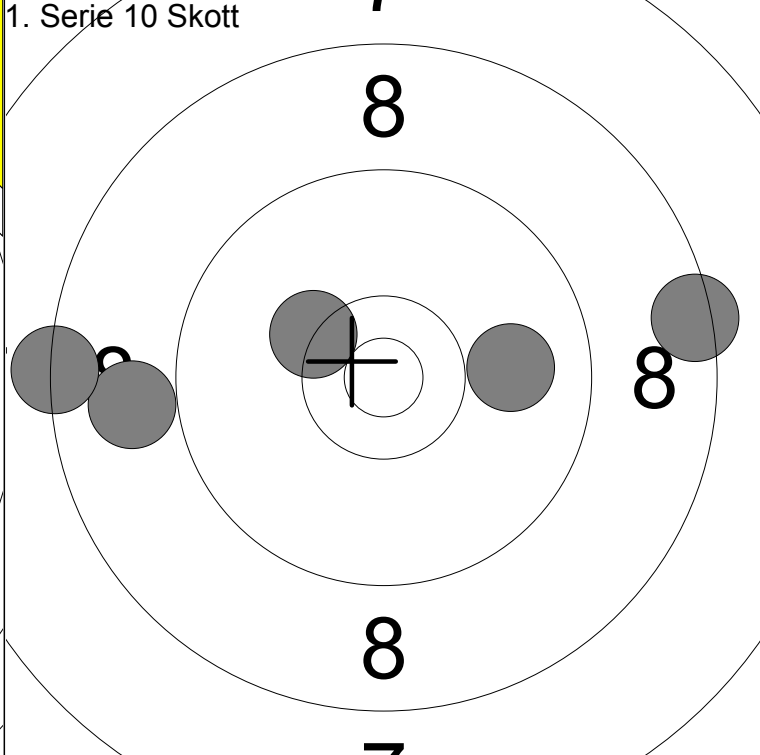
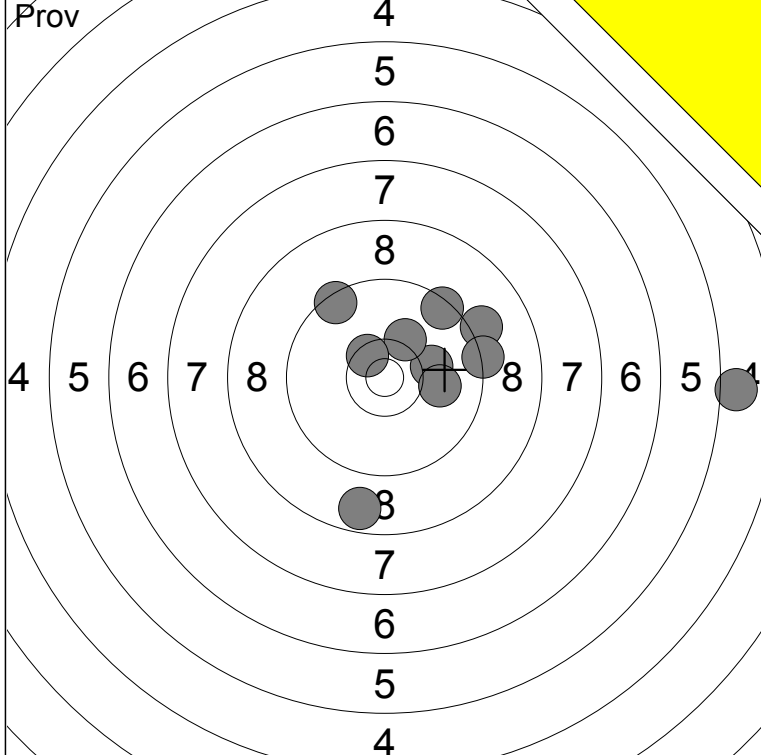

1: 8.7 ↓	6: 10.2 ↗	Serie	89
2: 9.4 ↗	7: 9.3 →		
3: 9.1 ↗	8: 10.0 →	Total	152
4: 5.0 →	9: 9.4 ↗		
5: 10.1 →	10: 10.5x ↗		

1: 9.9 →	Serie	43
2: 8.4 →		
3: 8.9 ←	Total	195
4: 10.3x ↗		
5: 8.3 ←		

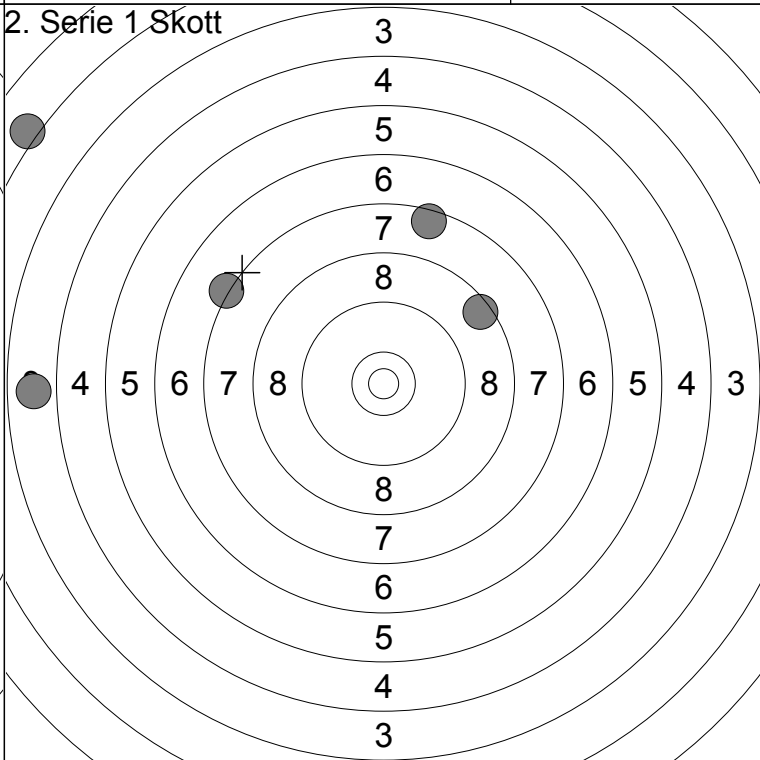
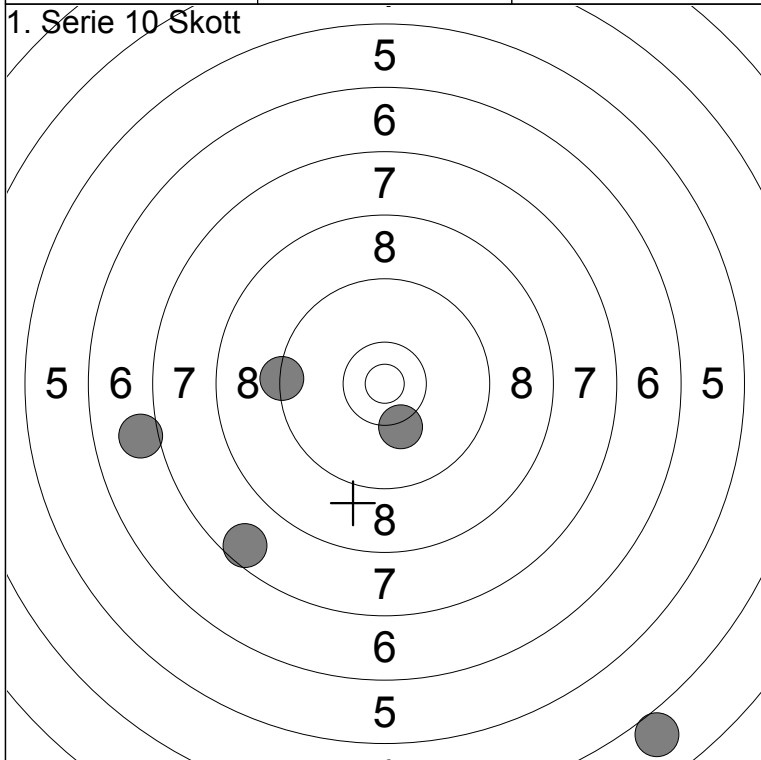

6: 9.3 ←	Serie	37
7: 10.2 ↓		
8: 7.0 ←	Total	232
9: 4.0 ↓		
10: 7.6 ↘		

1: 2.1 ↖	Serie	27
2: 3.8 ←		
3: 7.5 ↑	Total	259
4: 7.2 ↖		
5: 8.5 ↗		