

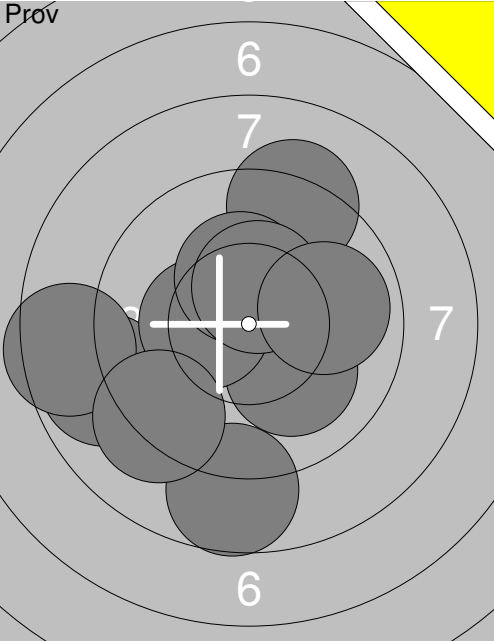

Skjutlag	Tavla	Siri Karlsson	
1	2	S	
08.04.2017		Vännäs Skf	
08.04.2017		UMEKULAN 2017	Umeå skytteallians
Prov		1: 8.9 ← 2: 8.7 ↓ 3: 10.1 ↘ 4: 9.2 ↑ 5: 10.4x ← 6: 8.5 ← 7: 10.3x ↑ 8: 10.4x ↑ 9: 9.9 → 10: 9.2 ↓	11: 6.5 ↘ 12: 8.2 ↑ 13: 9.5 ↑ 14: 10.5x ← 15: 9.7 ↘ 16: 10.0 ←
		Serie 95.6	Serie 54.4
		Total 0.0	Total 0.0
60 Skott		1: 10.5x ↘ 2: 10.4x ↘ 3: 8.8 ↖ 4: 10.5x ↗ 5: 8.9 → 6: 10.2x ← 7: 9.6 → 8: 10.4x ↓ 9: 9.0 ↑ 10: 10.4x →	11: 10.8x → 12: 10.2x ↓ 13: 10.2x → 14: 9.3 ↑ 15: 10.5x ← 16: 10.1 ↖ 17: 10.1 ↖ 18: 10.3x → 19: 10.6x ↘ 20: 8.6 ←
		Serie 98.7	Serie 100.7
		Total 98.7	Total 199.4
60 Skott		21: 10.1 ↑ 22: 9.0 ← 23: 10.4x ↗ 24: 10.6x ↗ 25: 10.1 ↑ 26: 10.2x ↗ 27: 9.3 ↓ 28: 9.5 ↓ 29: 9.1 ↓ 30: 9.8 →	31: 9.8 ↓ 32: 10.3x ← 33: 10.1 ↓ 34: 9.9 ↓ 35: 10.7x ← 36: 10.4x ↗ 37: 9.6 ← 38: 10.0 ↖ 39: 10.4x → 40: 10.2x →
		Serie 98.1	Serie 101.4
		Total 297.5	Total 398.9

	<p>1: 10.1 ↘ 2: 9.7 ↘ 3: 9.5 ↘ 4: 10.6x↗ 5: 10.2x↘ 6: 9.8 ↘ 7: 10.0 ↘ 8: 10.4x↗ 9: 10.3x→ 10: 10.5x↘</p> <p>Serie 101.1 Total 0.0</p>		<p>11: 10.2x↘ 12: 10.6x↘ 13: 10.3x↗ 14: 10.4x↘ 15: 10.4x↘ 16: 10.1 ↘ 17: 10.4x↘ 18: 10.7x↘ 19: 10.8x↘ 20: 9.9 ↘</p> <p>Serie 103.8 Total 0.0</p>
	<p>1: 10.1 ↗ 2: 9.7 → 3: 10.4x↘ 4: 10.1 ↘ 5: 10.4x↗ 6: 10.2x→ 7: 10.0 ↗ 8: 10.5x→ 9: 10.5x↘ 10: 10.4x↘</p> <p>Serie 102.3 Total 102.3</p>		<p>11: 10.2x↗ 12: 10.4x↘ 13: 10.0← 14: 10.5x↘ 15: 10.2x↘ 16: 10.7x↗ 17: 10.0→ 18: 9.7 ← 19: 9.9 ↘ 20: 10.7x→</p> <p>Serie 102.3 Total 204.6</p>
	<p>21: 10.2x↘ 22: 10.2x↘ 23: 10.4x↘ 24: 10.6x↘ 25: 10.4x↘ 26: 10.8x↘ 27: 10.5x↘ 28: 10.2x↘ 29: 10.5x↘ 30: 10.4x↘</p> <p>Serie 104.2 Total 308.8</p>		<p>31: 10.6x↘ 32: 10.7x↗ 33: 10.1 ↘ 34: 10.8x↘ 35: 10.3x→ 36: 10.4x↗ 37: 9.6 ↖ 38: 9.7 ↗ 39: 10.6x↘ 40: 10.8x↘</p> <p>Serie 103.6 Total 412.4</p>

Skjuttag	Tavla	Ylva Lundstedt	
S		Ramselefors Skf	
08.04.2017	UMEKULAN 2017	Umeå skytteallians	
Prov		1: 10.2x ↗ 2: 10.0 ↘ 3: 9.2 ↗ 4: 10.3x ↘ 5: 9.6 → 6: 9.5 ↗ 7: 8.8 → 8: 10.4x ↘ 9: 10.5x ↗ 10: 10.0 ←	11: 8.1 ↘ 12: 10.5x ↗ 13: 9.8 → 14: 7.5 ↘ 15: 9.6 → 16: 9.7 ↘
		Serie 98.5	Serie 55.2
		Total 0.0	Total 0.0
60 Skott		1: 9.2 ↘ 2: 8.8 ↘ 3: 9.2 ↘ 4: 8.6 ← 5: 9.4 ← 6: 9.8 ↘ 7: 10.5x ↗ 8: 9.7 → 9: 9.4 ↘ 10: 9.5 →	11: 9.3 ← 12: 10.0 → 13: 9.8 ↗ 14: 10.4x ↘ 15: 10.7x → 16: 9.6 ↗ 17: 10.2x ↗ 18: 9.4 ↗ 19: 9.5 → 20: 9.9 ↗
		Serie 94.1	Serie 98.8
		Total 94.1	Total 192.9
60 Skott		21: 9.8 ↗ 22: 10.0 ↗ 23: 10.5x ↗ 24: 9.3 ↗ 25: 9.2 ↘ 26: 10.4x ↘ 27: 8.8 ↗ 28: 8.7 ↗ 29: 8.3 ↘ 30: 10.1 ←	31: 10.0 ↘ 32: 9.1 ↘ 33: 10.3x ↗ 34: 9.3 ↘ 35: 9.4 ↘ 36: 10.2x ↗ 37: 10.4x ↗ 38: 5.4 → 39: 9.7 ↘ 40: 9.2 ↘
		Serie 95.1	Serie 93.0
		Total 288.0	Total 381.0

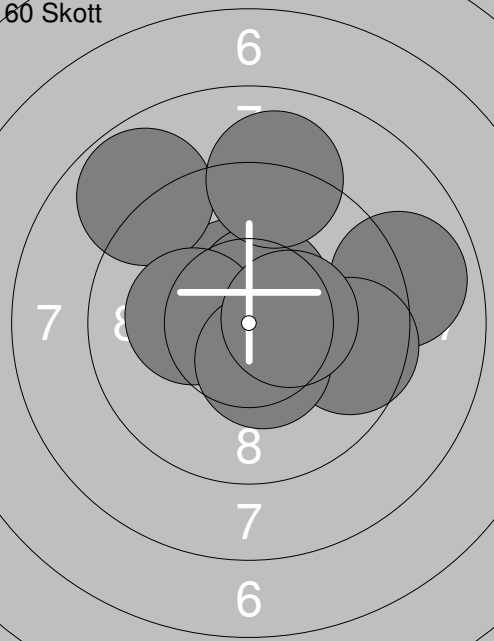
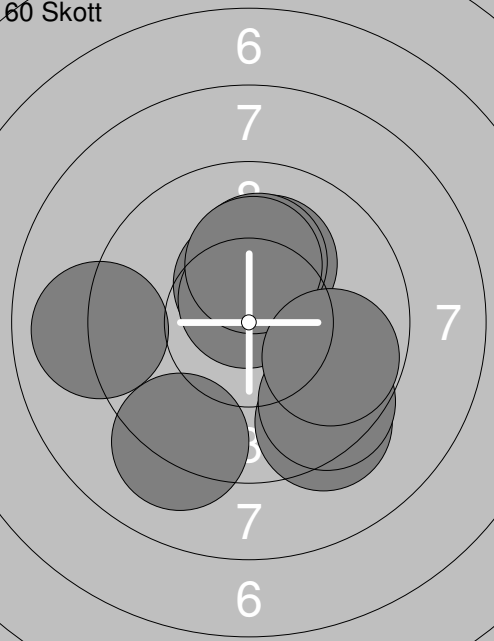

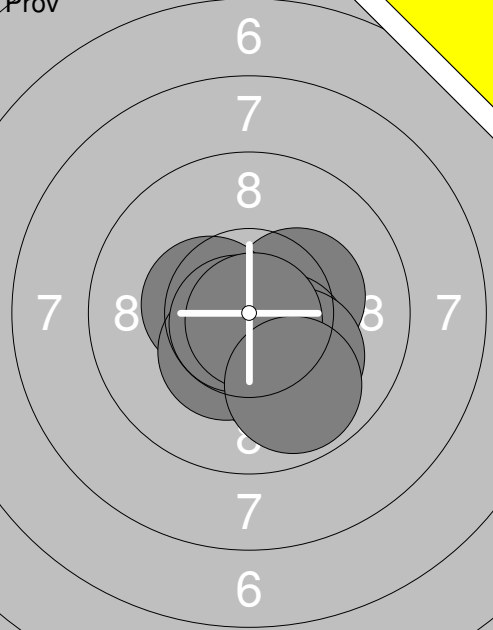
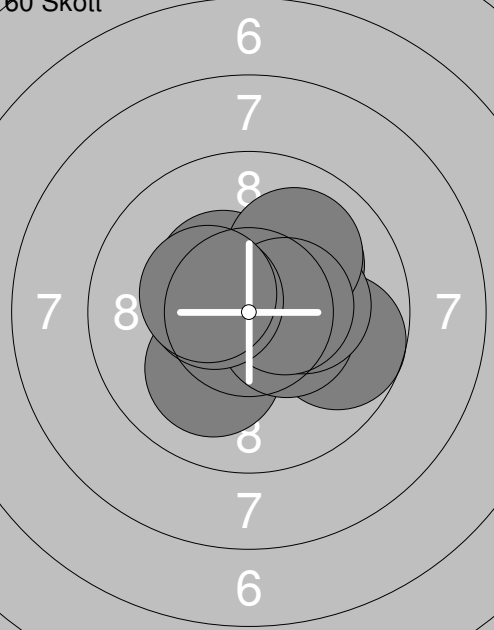
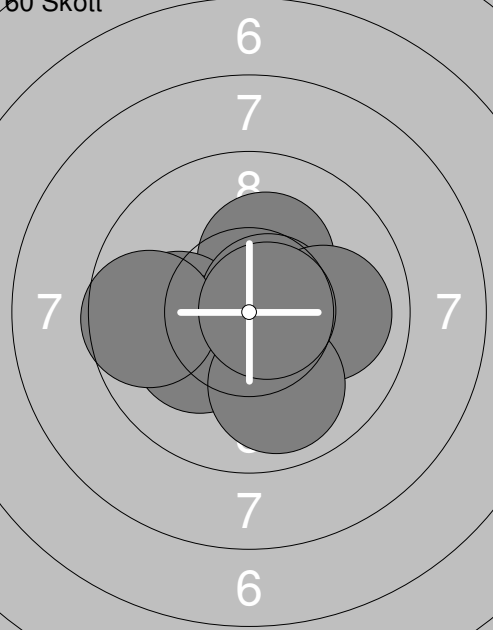
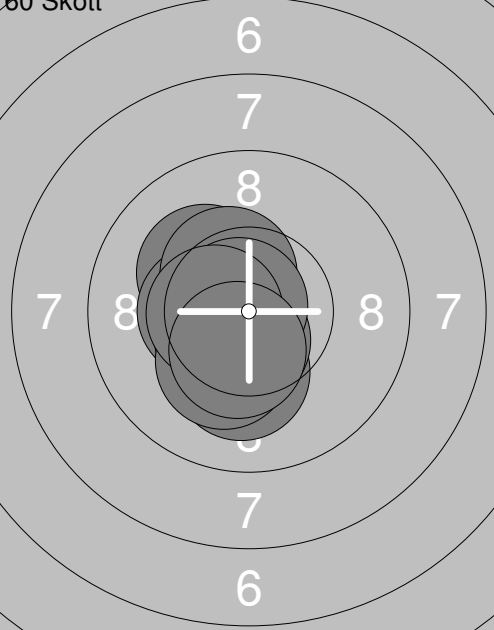
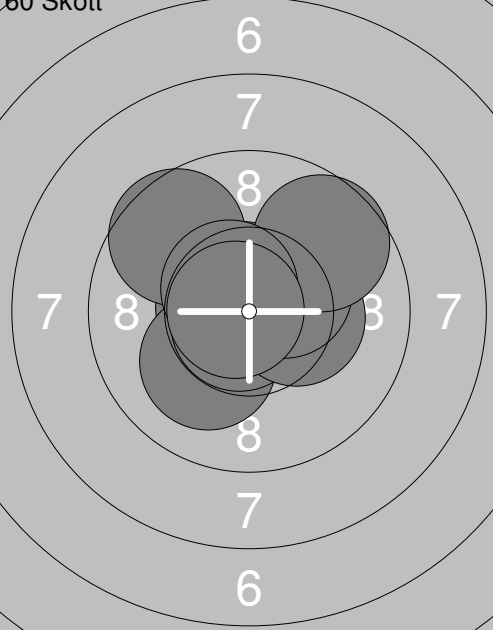
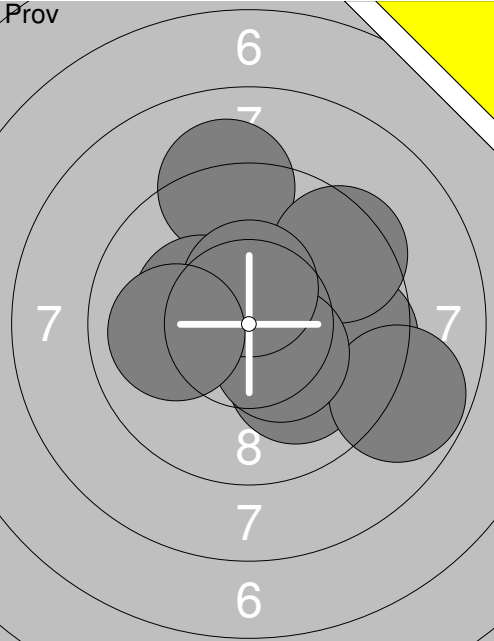
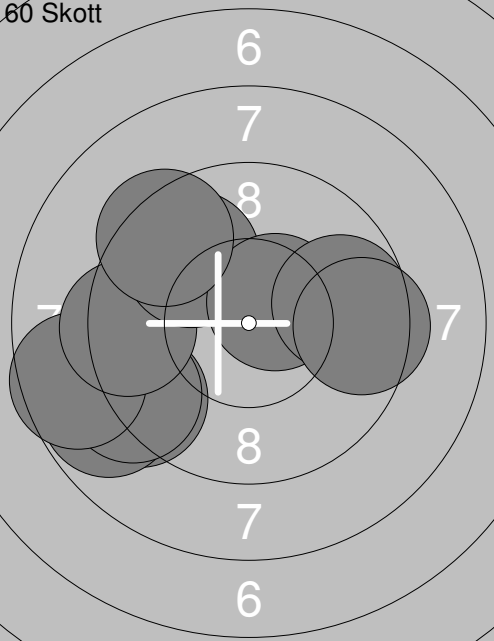
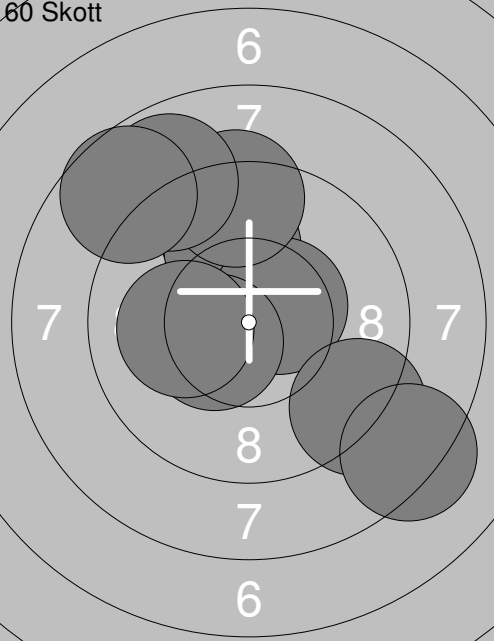
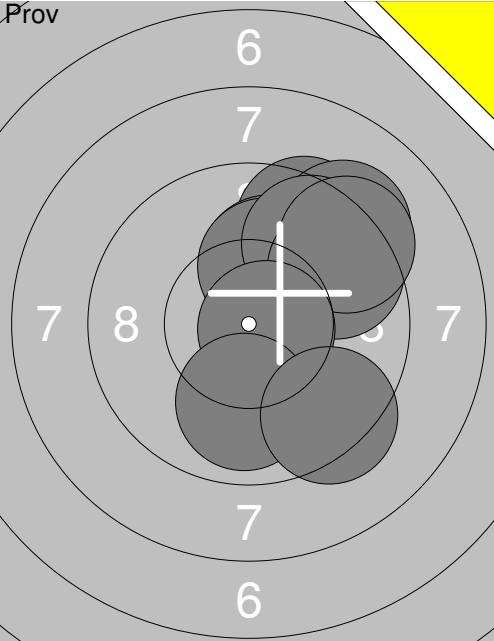
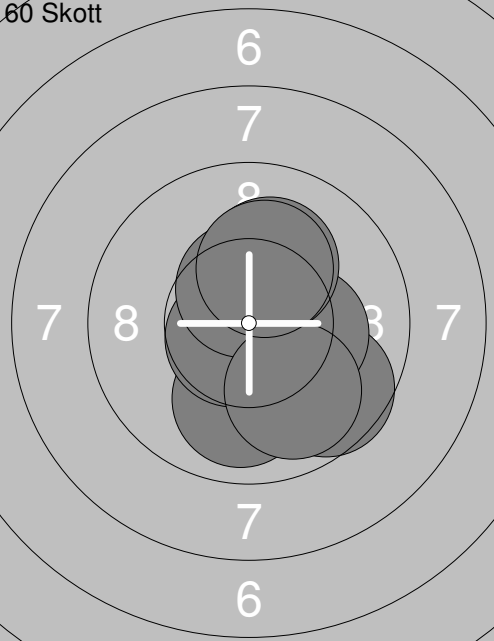
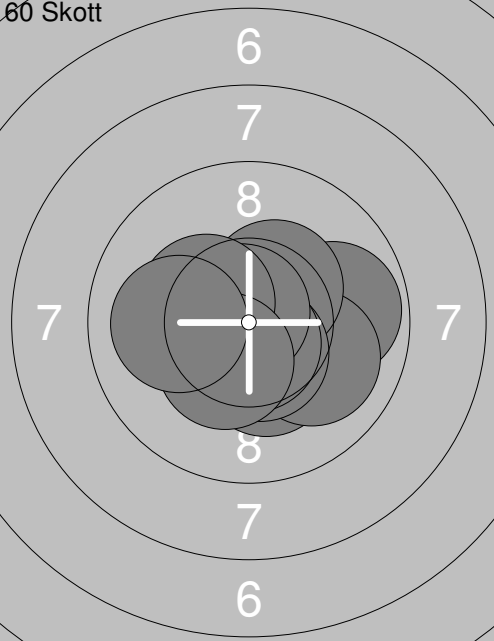
Skjutlag 1	Tavla 5	Melker Konradsson	
S		Umeå Skf	
08.04.2017		UMEKULAN 2017	Umeå skytteallians
Pröv 	1: 10.2x → 2: 8.6 → 3: 8.9 → 4: 8.9 ↓ 5: 10.2x ↓ 6: 9.8 → 7: 9.3 ↓ 8: 10.5x → 9: 10.0 ← 10: 9.8 ←	Pröv 	11: 9.4 ↓ 12: 10.3x ↓ 13: 8.8 ↗ 14: 10.0 ↗ 15: 9.6 → 16: 10.5x ↗ 17: 10.1 ↗ 18: 8.9 → 19: 10.7x ↗ 20: 10.7x →
Serie 96.2		Serie 99.0	
Total 0.0		Total 0.0	
Pröv 	21: 9.5 ↓ 22: 9.8 ↓ 23: 10.6x ↗ 24: 10.1 →	60 Skott 	1: 9.4 ↓ 2: 10.0 → 3: 10.2x ↓ 4: 10.4x → 5: 10.5x ↗ 6: 10.1 ↓ 7: 10.5x ← 8: 10.2x ↑ 9: 10.1 ↗ 10: 10.0 ↗
Serie 40.0		Serie 101.4	
Total 0.0		Total 101.4	
60 Skott 	11: 8.9 ↗ 12: 8.9 ↑ 13: 10.3x ↗ 14: 9.1 ↑ 15: 8.6 ↗ 16: 8.8 ↑ 17: 9.0 ↑ 18: 10.4x ↑ 19: 10.5x → 20: 9.3 ↑	60 Skott 	21: 8.9 ↗ 22: 7.8 ↑ 23: 10.0 ↗ 24: 10.1 ↑ 25: 8.9 ↑ 26: 9.8 ↗ 27: 10.1 ← 28: 10.8x ← 29: 10.3x ↑ 30: 9.8 ↑
Serie 93.8		Serie 96.5	
Total 195.2		Total 291.7	
60 Skott 	31: 10.7x ↓ 32: 10.3x ↗ 33: 9.6 → 34: 9.5 → 35: 9.6 → 36: 9.6 ↗ 37: 8.3 → 38: 10.2x → 39: 9.6 ↗ 40: 10.1 ↑		
Serie 97.5			
Total 389.2			

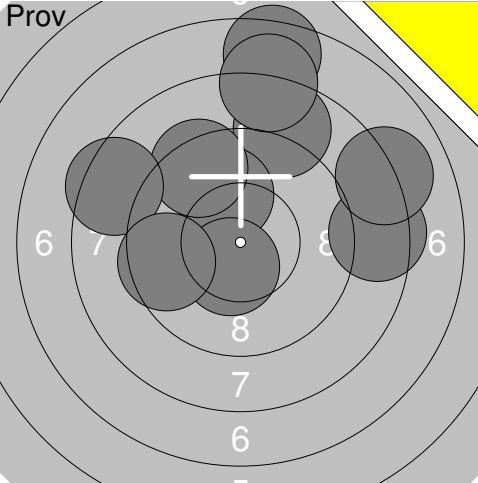
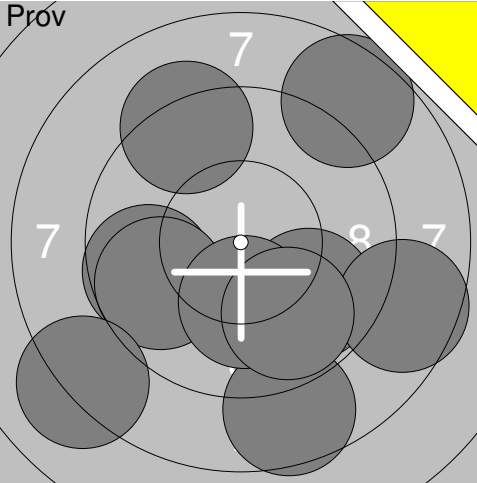
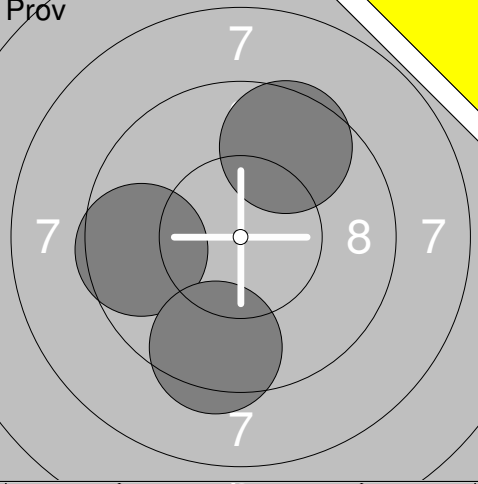
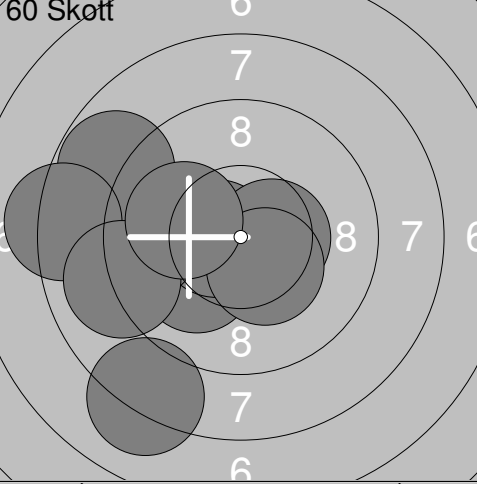
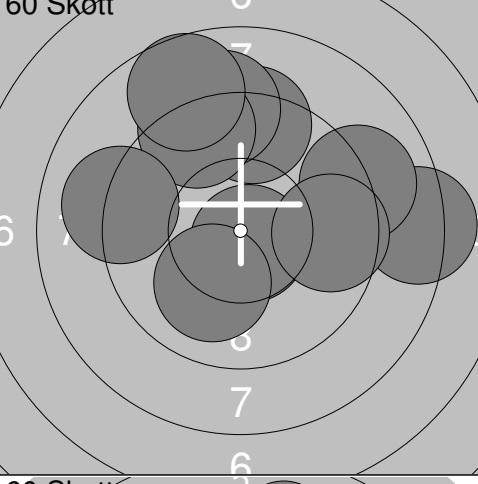
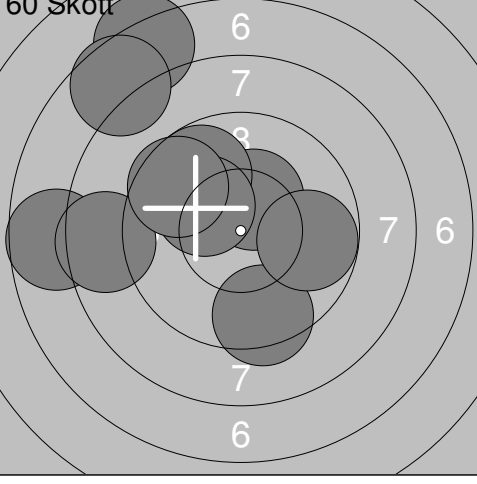
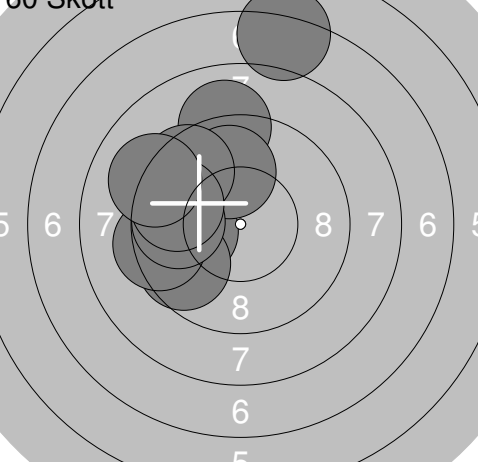
Skjuttag	Tavla	Erika Gustafsson	
1	6		
S	Ramselefors Skf		
08.04.2017	UMEKULAN 2017	Umeå skytteallians	
Prov		1: 9.5 ↗ 2: 9.2 ↗ 3: 10.1 ↗ 4: 10.2x↗ 5: 9.6 ↗ 6: 9.6 ↗ 7: 9.3 ↗ 8: 10.7x➤ 9: 9.9 ↓ 10: 9.4 ↘ Serie 97.5 Total 0.0	11: 10.4x➤ 12: 10.4x↓ 13: 10.0 ↙ 14: 10.0 ↓ 15: 9.6 ← 16: 9.7 ← Serie 60.1 Total 0.0
60 Skott		1: 10.7x↗ 2: 9.6 ↘ 3: 10.6x↗ 4: 10.0 ↓ 5: 10.3x➤ 6: 10.2x↗ 7: 10.7x↙ 8: 10.5x↗ 9: 9.9 ↘ 10: 10.2x↗ Serie 102.7 Total 102.7	11: 10.3x↗ 12: 10.2x➤ 13: 10.8x↘ 14: 10.1 → 15: 10.5x↘ 16: 10.9x➤ 17: 10.5x↙ 18: 10.3x↙ 19: 10.2x↗ 20: 10.6x↗ Serie 104.4 Total 207.1
60 Skott		21: 9.8 → 22: 10.3x↓ 23: 10.0 ➤ 24: 10.4x↗ 25: 10.5x↓ 26: 10.7x↓ 27: 10.8x↘ 28: 10.3x↘ 29: 10.4x↙ 30: 10.0 ← Serie 103.2 Total 310.3	31: 10.1 ↓ 32: 10.4x↗ 33: 9.7 ↘ 34: 10.6x↗ 35: 10.6x↙ 36: 10.5x↓ 37: 9.5 ↗ 38: 10.4x➤ 39: 10.8x↙ 40: 10.7x↓ Serie 103.3 Total 413.6

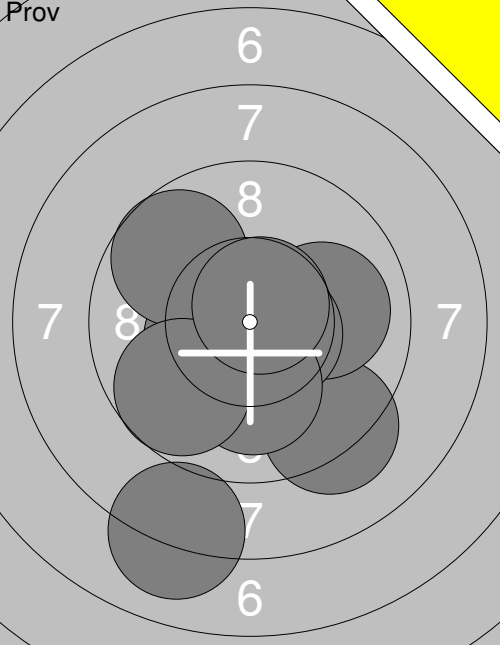
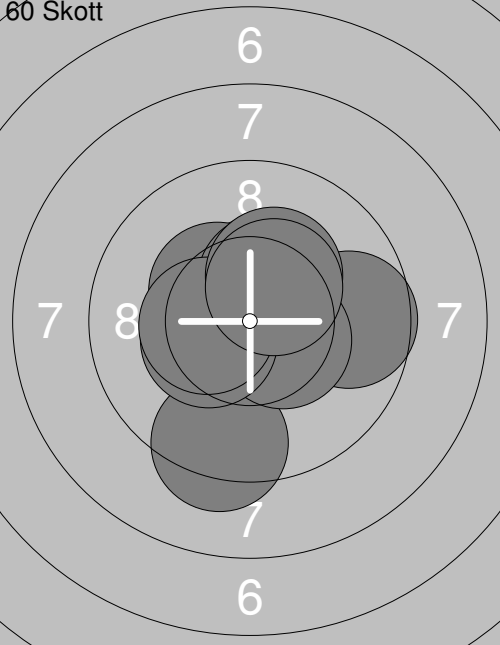
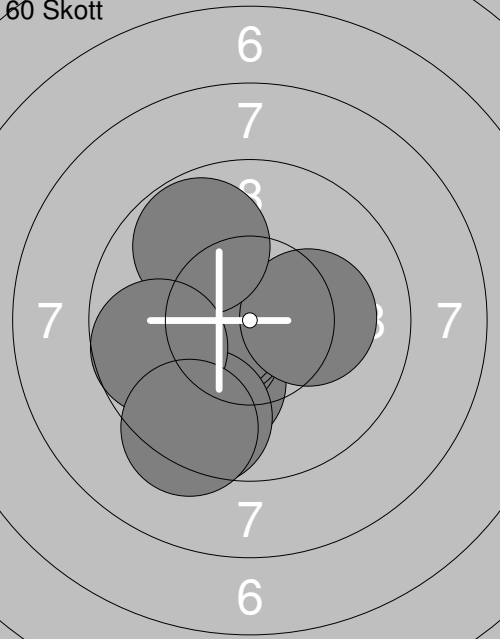
Skjuttag 1	Tavla 7	Dennis Alenius	
S		Ramselefors Skf	
08.04.2017		UMEKULAN 2017	Umeå skytteallians
Prov 	1: 8.4 → 2: 8.7 ↑ 3: 8.0 → 4: 10.0 ↑ 5: 7.5 ↑ 6: 8.0 ↑ 7: 9.4 ↑ 8: 10.5x ↓ 9: 8.4 ← 10: 9.5 ←	Prov 	11: 9.2 ↑ 12: 9.7 ← 13: 9.7 ← 14: 8.1 ← 15: 8.6 ↓ 16: 9.8 ↓ 17: 8.6 → 18: 8.6 ↑ 19: 10.1 ↓ 20: 9.8 ↓
	Serie 88.4 Total 0.0		Serie 92.2 Total 0.0
Prov 	21: 9.6 ↑ 22: 9.6 ← 23: 9.4 ↓	60 Skott 	1: 8.1 ↓ 2: 10.1 ← 3: 10.6x ← 4: 10.5x → 5: 9.4 ← 6: 8.8 ↑ 7: 8.2 ← 8: 10.4x ↓ 9: 9.0 ← 10: 10.0 ←
	Serie 28.6 Total 0.0		Serie 95.1 Total 95.1
60 Skott 	11: 9.3 ↑ 12: 8.3 → 13: 10.7x ↓ 14: 9.1 ↑ 15: 10.0 ↓ 16: 9.3 ↑ 17: 9.0 → 18: 8.7 ↑ 19: 9.6 → 20: 9.1 ←	60 Skott 	21: 10.4x ↑ 22: 7.7 ← 23: 9.8 ↑ 24: 9.4 ↓ 25: 8.5 ← 26: 9.8 → 27: 7.2 ↑ 28: 10.2x ↑ 29: 9.6 ↑ 30: 7.6 ↑
	Serie 93.1 Total 188.2		Serie 90.2 Total 278.4
60 Skott 	31: 10.0 ← 32: 9.6 ← 33: 9.1 ↑ 34: 7.2 ↑ 35: 9.3 ← 36: 9.9 ↑ 37: 9.5 ↑ 38: 9.8 ← 39: 9.7 ← 40: 9.1 ↑		
	Serie 93.2 Total 371.6		

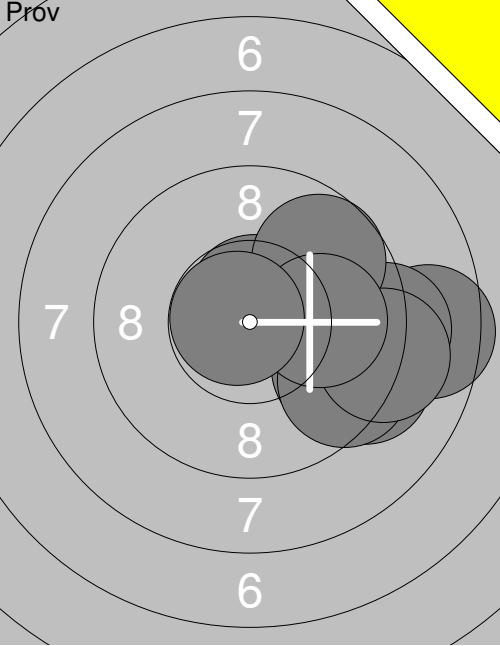
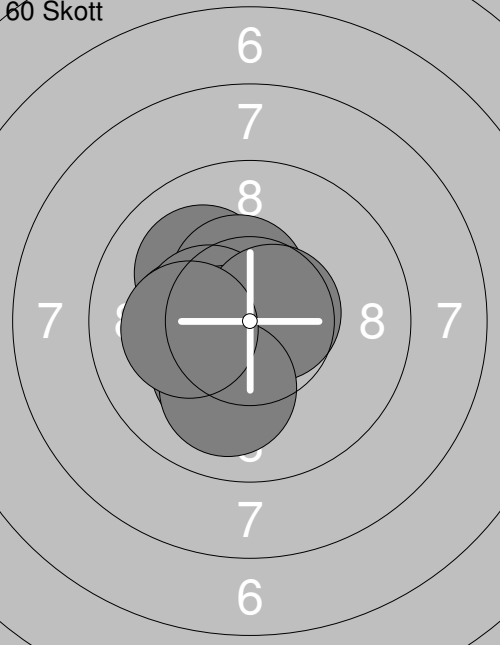
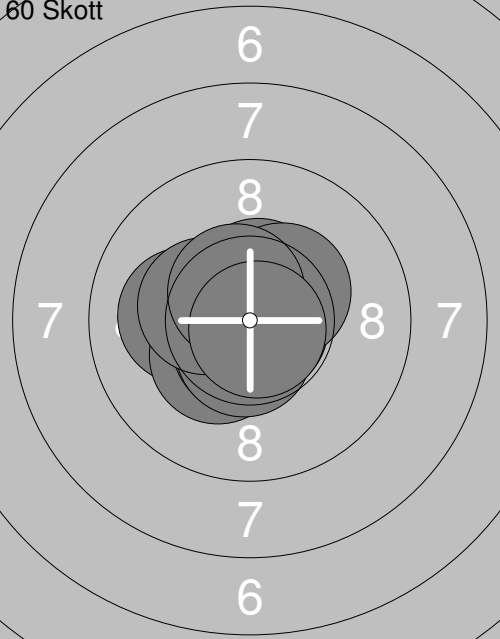
Skjuttag	Tavla	Oliver Eklund	
S		Ramselefors Skf	
08.04.2017	UMEKULAN 2017	Umeå skytteallians	
Prov		1: 10.6x ↘ 2: 9.2 ↘ 3: 10.4x ↘ 4: 8.1 ↓ 5: 9.7 ↖ 6: 10.0 → 7: 10.6x ↘ 8: 10.1 ↓ 9: 9.7 ↖ 10: 10.7x ↗ Serie 99.1 Total 0.0	11: 9.5 ↖ 12: 9.0 ↓ 13: 10.7x ↘ 14: 10.6x ↘ 15: 9.7 ← 16: 9.8 ← 17: 10.0 ↗ Serie 69.3 Total 0.0
60 Skott		1: 9.3 ↓ 2: 10.5x ↗ 3: 10.4x ↘ 4: 9.7 → 5: 10.4x ↗ 6: 10.5x ↘ 7: 10.4x ↘ 8: 10.4x ← 9: 10.3x ↗ 10: 10.4x ↗ Serie 102.3 Total 102.3	11: 9.3 ↓ 12: 10.3x ↘ 13: 9.6 ↓ 14: 10.5x ↘ 15: 10.6x ← 16: 10.0 → 17: 9.1 ↓ 18: 10.5x ↓ 19: 10.6x ← 20: 10.6x ↘ Serie 101.1 Total 203.4
60 Skott		21: 10.0 ↓ 22: 10.4x ↘ 23: 10.5x ← 24: 10.6x ← 25: 10.5x ← 26: 10.2x → 27: 9.8 ↖ 28: 9.5 ↓ 29: 9.7 ← 30: 9.3 ↓ Serie 100.5 Total 303.9	31: 10.6x → 32: 9.8 ↖ 33: 10.7x ↘ 34: 9.6 ← 35: 10.2x ← 36: 10.1 ↖ 37: 10.0 ↖ 38: 9.2 → 39: 8.7 → 40: 9.2 ↓ Serie 98.1 Total 402.0

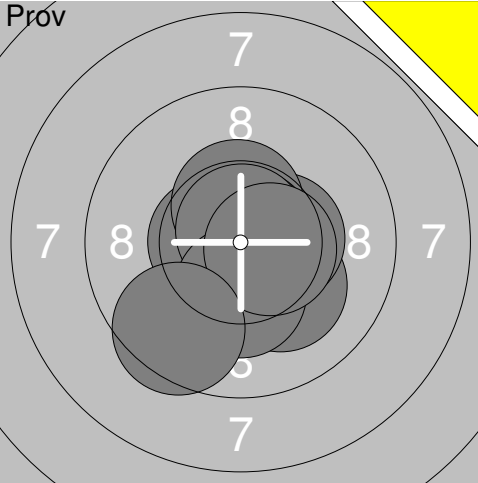
Skjutlag	Tavla	Irma Karlsson	
S	Vännäs Skf		
08.04.2017	UMEKULAN 2017	Umeå skytteallians	
Prov		1: 9.2 ↘ 2: 8.6 → 3: 10.7x↗ 4: 9.1 → 5: 9.7 ↗ 6: 9.6 ↘ 7: 9.5 ↘ 8: 9.1 → 9: 10.0 → 10: 10.8x↖ Serie 96.3 Total 0.0	11: 10.1 ↙ 12: 10.7x↘ 13: 10.4x↗ 14: 10.2x↖ 15: 10.2x↖ 16: 10.5x↗ 17: 10.6x↘ Serie 72.7 Total 0.0
60 Skott		1: 10.1 ↙ 2: 10.4x↗ 3: 10.2x↖ 4: 10.2x↘ 5: 10.4x↖ 6: 10.6x↖ 7: 10.5x↖ 8: 10.6x↗ 9: 10.0 ↘ 10: 10.2x↖ Serie 103.2 Total 103.2	11: 10.8x↖ 12: 10.2x↘ 13: 10.3x↖ 14: 10.6x↗ 15: 10.4x↘ 16: 10.2x↘ 17: 10.8x↖ 18: 10.4x↖ 19: 10.2x↘ 20: 10.2x↖ Serie 104.1 Total 207.3
60 Skott		21: 10.1↖ 22: 10.3x↘ 23: 10.8x↘ 24: 10.5x↗ 25: 10.4x↗ 26: 10.6x↘ 27: 10.6x↘ 28: 10.3x↖ 29: 10.5x↗ 30: 10.8x↘ Serie 104.9 Total 312.2	31: 10.1↖ 32: 10.4x↗ 33: 9.4 ↖ 34: 10.8x↖ 35: 10.3x↘ 36: 10.3x↘ 37: 10.5x↗ 38: 10.2x↗ 39: 10.5x↖ 40: 10.0 ↘ Serie 102.5 Total 414.7

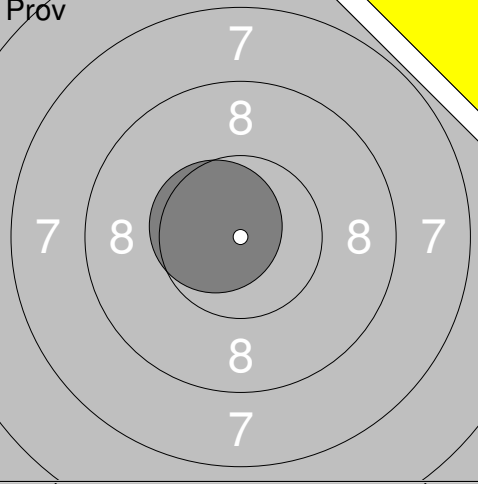
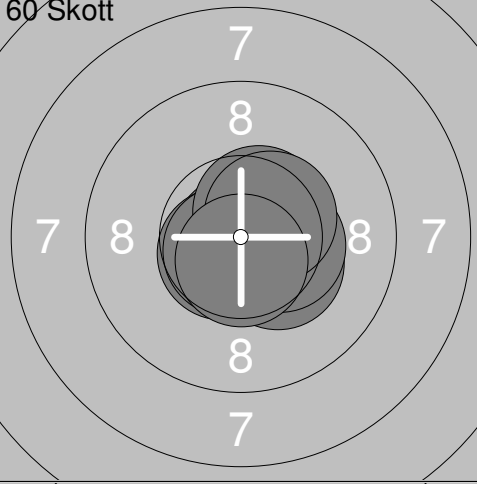
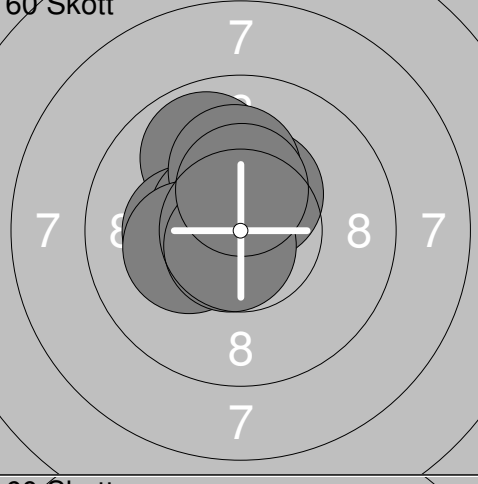
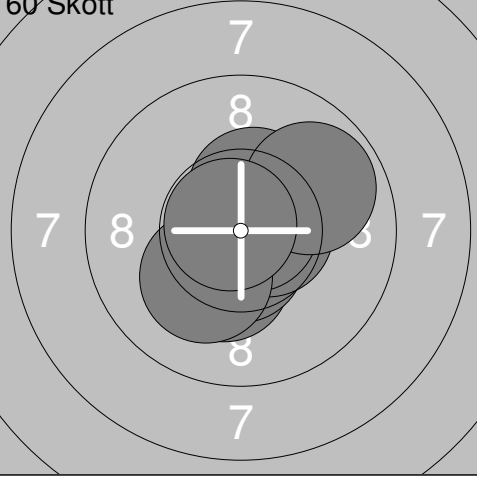
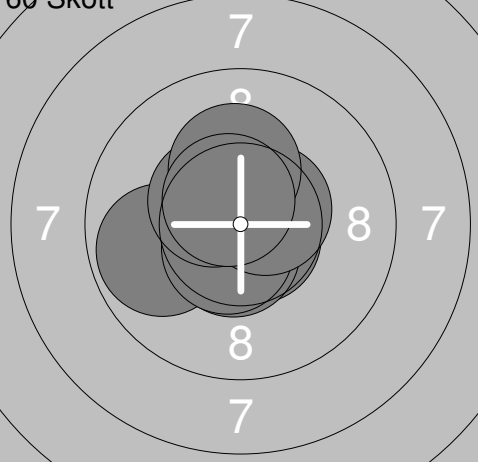
Skjutlag	Tavla	Agnes Ebbhagen			
1	10	Ramselefors Skf			
08.04.2017	UMEKULAN 2017	Umeå skytteallians			
Prov		1: 10.2x ↘ 2: 10.4x → 3: 10.6x ← 4: 10.7x → 5: 10.5x ↑ 6: 10.8x ↗ 7: 10.8x ↑ 8: 10.3x ↓ 9: 10.5x → 10: 9.5 ↙	Prov		11: 10.8x ↙ 12: 10.2x ↓ 13: 10.7x ← 14: 10.6x ↓ 15: 10.5x ↓ 16: 10.6x ↑ 17: 10.9x ← 18: 10.2x ↖ 19: 10.7x ↑ 20: 10.6x ↑
	Serie	104.3		Serie	105.8
	Total	0.0		Total	0.0
Prov		21: 10.6x ↖	60 Skott		1: 10.4x → 2: 10.3x ↘ 3: 10.9x ↓ 4: 10.8x → 5: 10.4x → 6: 10.6x ↙ 7: 10.7x ↙ 8: 10.5x ↗ 9: 10.5x ↗ 10: 10.6x ↓
	Serie	10.6		Serie	105.7
	Total	0.0		Total	105.7
60 Skott		11: 9.9 ↖ 12: 10.7x ← 13: 10.2x ← 14: 10.7x ← 15: 10.6x ↖ 16: 10.4x ↗ 17: 10.1 ↑ 18: 10.2x ← 19: 10.7x ↙ 20: 10.4x ↑	60 Skott		21: 10.6x ↗ 22: 10.5x ↗ 23: 10.3x ↓ 24: 10.6x ↓ 25: 10.6x → 26: 10.8x → 27: 10.4x ↑ 28: 9.9 ↗ 29: 10.2x ↙ 30: 10.8x ↖
	Serie	103.9		Serie	104.7
	Total	209.6		Total	314.3
60 Skott		31: 10.6x ↑ 32: 10.5x ← 33: 10.7x ↘ 34: 9.8 ← 35: 10.6x ↓ 36: 10.6x ↙ 37: 10.6x ↗ 38: 10.5x ↖ 39: 10.2x ↑ 40: 10.6x ↖			
	Serie	104.7			
	Total	419.0			

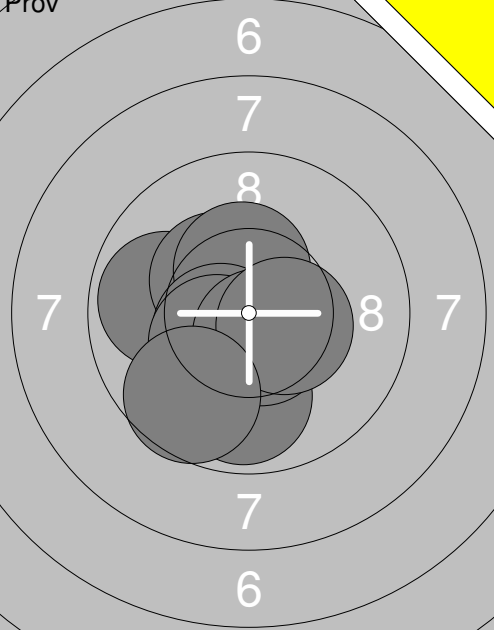
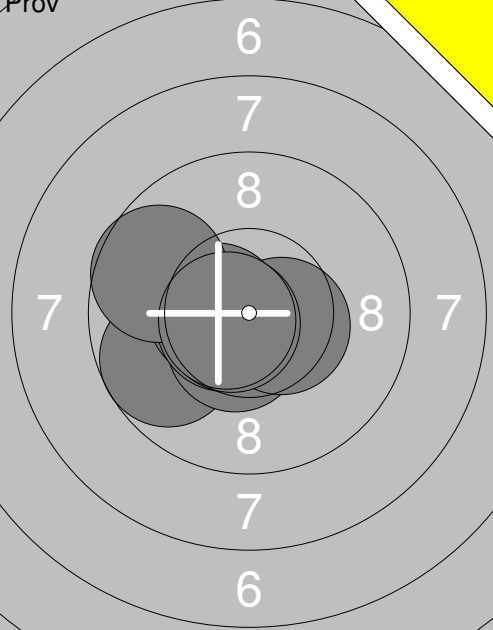
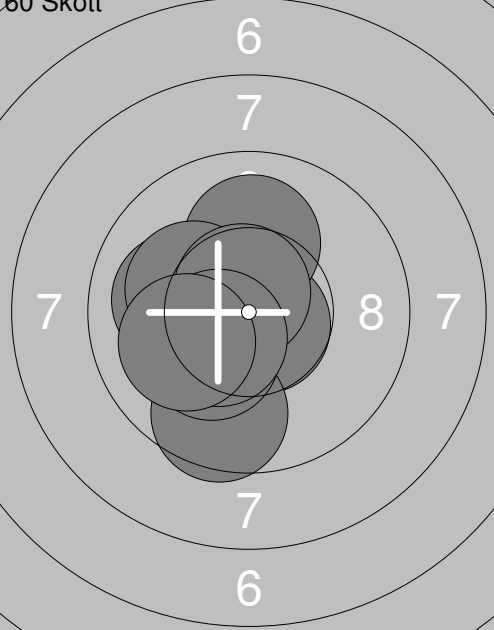
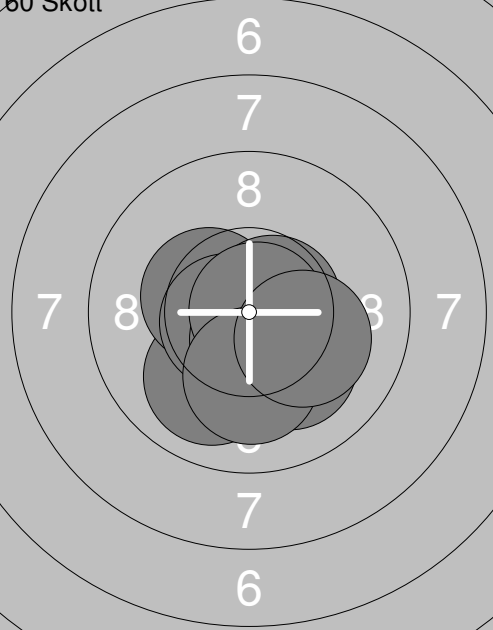
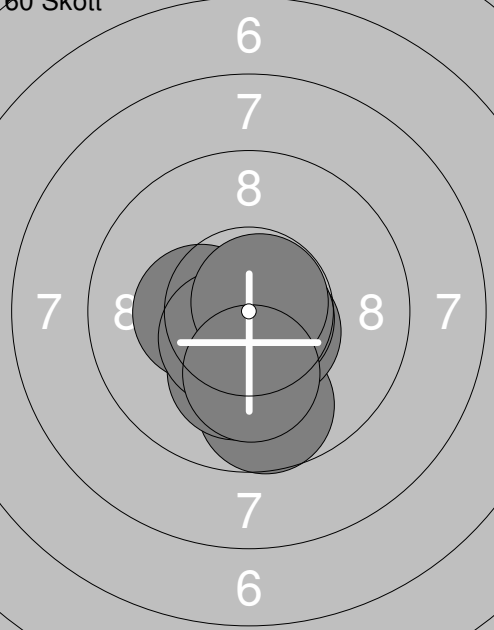
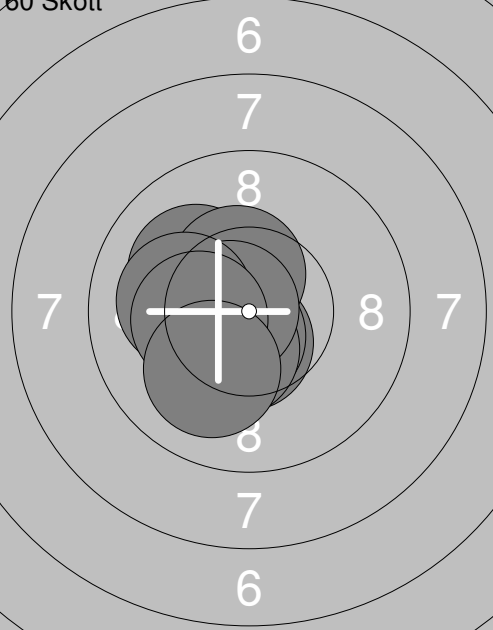
<p>Prov</p> 	<p>1: 10.7x ↘</p> <p>2: 9.9 ←</p> <p>3: 10.4x ↘</p> <p>4: 9.9 ↓</p> <p>5: 10.4x ↗</p> <p>6: 10.5x ↘</p> <p>7: 10.4x ↘</p> <p>8: 10.6x ↘</p> <p>9: 10.5x →</p> <p>10: 9.7 ↓</p> <p>Serie 103.0</p> <p>Total 0.0</p>	<p>Prov</p> 	<p>11: 9.7 ↙</p> <p>12: 10.5x ↘</p> <p>13: 10.5x →</p> <p>14: 10.5x ↘</p> <p>15: 10.6x ↘</p> <p>16: 10.7x ↘</p> <p>17: 9.7 ↙</p> <p>18: 10.6x ↘</p> <p>Serie 82.8</p> <p>Total 0.0</p>
<p>60 Skott</p> 	<p>1: 10.7x ↘</p> <p>2: 10.4x ↘</p> <p>3: 10.0 ←</p> <p>4: 10.0 ↑</p> <p>5: 10.2x ↘</p> <p>6: 10.7x ↗</p> <p>7: 9.6 ↓</p> <p>8: 10.2x ↘</p> <p>9: 10.4x ↘</p> <p>10: 10.0 ←</p> <p>Serie 102.2</p> <p>Total 102.2</p>	<p>60 Skott</p> 	<p>11: 10.0 ↓</p> <p>12: 10.1 ↓</p> <p>13: 10.6x ↘</p> <p>14: 10.4x ↘</p> <p>15: 10.6x →</p> <p>16: 10.6x ↘</p> <p>17: 10.6x ↘</p> <p>18: 10.8x →</p> <p>19: 10.1 ↓</p> <p>20: 10.2x →</p> <p>Serie 104.0</p> <p>Total 206.2</p>
<p>60 Skott</p> 	<p>21: 10.5x ↘</p> <p>22: 10.6x ↘</p> <p>23: 9.7 ↓</p> <p>24: 10.3x ←</p> <p>25: 10.6x ↘</p> <p>26: 10.7x →</p> <p>27: 10.2x ↘</p> <p>28: 10.5x ↘</p> <p>29: 10.8x ↗</p> <p>30: 10.1 ↓</p> <p>Serie 104.0</p> <p>Total 310.2</p>	<p>60 Skott</p> 	<p>31: 10.5x ↘</p> <p>32: 10.6x ↘</p> <p>33: 10.4x ↘</p> <p>34: 10.3x ↘</p> <p>35: 10.1 ↙</p> <p>36: 10.4x ↗</p> <p>37: 10.7x ↘</p> <p>38: 10.1 ←</p> <p>39: 10.3x ↘</p> <p>40: 10.1 ↓</p> <p>Serie 103.5</p> <p>Total 413.7</p>

Skjutlag 1	Tavla 12	Elias Nilsson	
S		Ramselefors Skf	
08.04.2017		UMEKULAN 2017	Umeå skytteallians
Prov 	1: 8.8 → 2: 10.2x ↙ 3: 9.5 → 4: 7.8 ↓ 5: 10.1 ← 6: 10.6x ↙ 7: 9.8 → 8: 10.1 ↗ 9: 9.7 ↘ 10: 9.9 ↑ Serie 96.5 Total 0.0	Prov 	11: 10.0 ↙ 12: 9.9 → 13: 10.5x ↙ 14: 9.8 ↗ 15: 9.6 ↗ 16: 10.5x ↙ 17: 9.0 ↙ 18: 9.4 ↓ 19: 10.1 ↗ 20: 9.1 ↙ Serie 97.9 Total 0.0
Prov 	21: 9.9 ↙ 22: 10.3x ↗ 23: 9.7 ↘ 25: 10.1 ↙ 26: 9.5 ← Serie 49.5 Total 0.0	60 Skott 	1: 9.4 ↓ 2: 10.4x ↗ 3: 10.5x ← 4: 10.6x ← 5: 9.7 ↙ 6: 9.5 ↙ 7: 9.5 ↓ 8: 9.6 ← 9: 10.0 → 10: 9.4 ↙ Serie 98.6 Total 98.6
60 Skott 	11: 9.7 ↓ 12: 10.2x ↓ 13: 10.0 ← 14: 10.3x ← 15: 10.4x ↓ 16: 8.9 ↙ 17: 9.4 ↓ 18: 10.4x ↑ 19: 10.9x ↙ 20: 9.0 ↙ Serie 99.2 Total 197.8	60 Skott 	21: 9.1 ← 22: 10.7x ← 23: 9.3 ↙ 24: 9.1 ↙ 25: 8.7 ↙ 26: 9.3 ← 27: 9.5 ↓ 28: 9.8 ↓ 29: 9.8 ← 30: 10.2x ↙ Serie 95.5 Total 293.3
60 Skott 	31: 10.7x ↗ 32: 10.6x ↓ 33: 10.3x ↗ 34: 10.8x ↘ 35: 9.3 ↙ 36: 9.7 ↙ 37: 9.6 ← 38: 9.7 ← 39: 9.8 ↓ 40: 10.3x ↓ Serie 100.8 Total 394.1		

		<p>1: 10.3x ↘</p> <p>2: 10.4x ↓</p> <p>3: 10.2x ↓</p> <p>4: 10.2x →</p> <p>5: 10.5x ↘</p> <p>6: 10.2x →</p> <p>7: 10.0 →</p> <p>8: 10.2x ↗</p> <p>9: 10.1 ↑</p> <p>10: 10.8x ↘</p> <hr/> <p>Serie 102.9</p> <p>Total 0.0</p>	<p>11: 10.1 ↑</p> <p>12: 10.3x ↑</p> <p>13: 10.1 ↖</p> <p>14: 10.3x ↗</p> <p>15: 10.6x ↘</p> <p>16: 10.0 ↗</p> <p>17: 10.4x ↘</p> <p>18: 10.1 →</p> <p>19: 10.7x ↘</p> <hr/> <p>Serie 92.6</p> <p>Total 0.0</p>
--	--	--	---

		<p>1: 10.3x ↘</p> <p>2: 10.2x ↘</p> <p>3: 9.5 ←</p> <p>4: 10.7x ↑</p> <p>5: 9.8 ←</p> <p>6: 10.5x ↓</p> <p>7: 10.4x ↗</p> <p>8: 10.6x ↘</p> <p>9: 10.8x ↗</p> <p>10: 10.7x ↘</p> <hr/> <p>Serie 103.5</p> <p>Total 103.5</p>	<p>11: 10.5x ↘</p> <p>12: 9.9 ↖</p> <p>13: 9.6 ↙</p> <p>14: 10.5x ↘</p> <p>15: 10.0 ←</p> <p>16: 10.4x ↘</p> <p>17: 9.9 ←</p> <p>18: 9.9 ←</p> <p>19: 10.1 ←</p> <p>20: 10.1 ↑</p> <hr/> <p>Serie 100.9</p> <p>Total 204.4</p>
--	--	--	--

		<p>21: 10.8x ↘</p> <p>22: 10.2x ↗</p> <p>23: 10.6x ↗</p> <p>24: 10.3x ↗</p> <p>25: 10.2x ↘</p> <p>26: 9.9 ↑</p> <p>27: 9.8 ↑</p> <p>28: 10.6x ↗</p> <p>29: 10.2x ↗</p> <p>30: 10.2x ↘</p> <hr/> <p>Serie 102.8</p> <p>Total 307.2</p>	<p>31: 10.6x ↘</p> <p>32: 9.9 ↖</p> <p>33: 10.5x ↘</p> <p>34: 10.2x ↘</p> <p>35: 10.7x ↘</p> <p>36: 10.7x ↗</p> <p>37: 9.6 ↗</p> <p>38: 10.7x ↓</p> <p>39: 10.4x ↗</p> <p>40: 10.6x ↘</p> <hr/> <p>Serie 103.9</p> <p>Total 411.1</p>
--	--	---	---

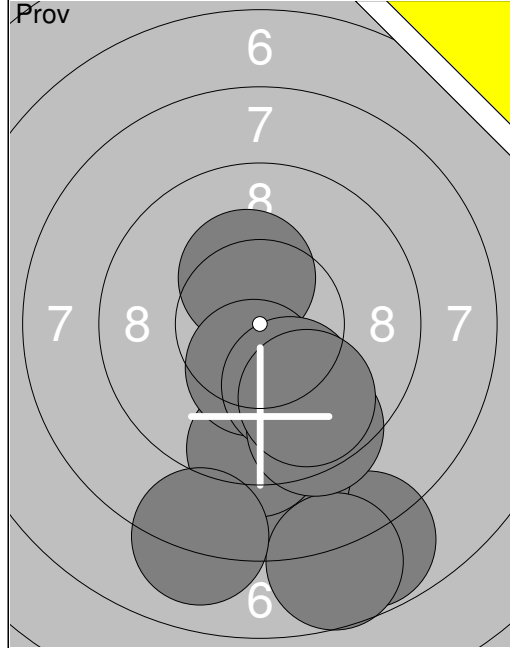

1:	7.8	↘
2:	8.9	↓
3:	9.3	↓
4:	10.3x	↗
5:	7.7	↘
6:	10.4x	↘
7:	10.1	↘
8:	9.4	↘
9:	9.8	↘
10:	8.1	↘
Serie	91.8	
Total	0.0	

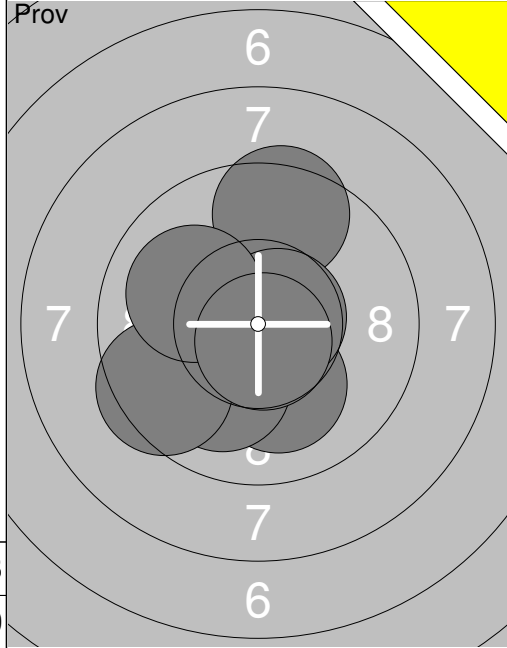

11:	10.4x	↘
12:	10.4x	↘
13:	9.5	↗
14:	10.1	↘
15:	10.1	↘
16:	9.5	↙
17:	10.7x	↗
18:	10.0	↙
19:	10.7x	↘
Serie	91.4	
Total	0.0	

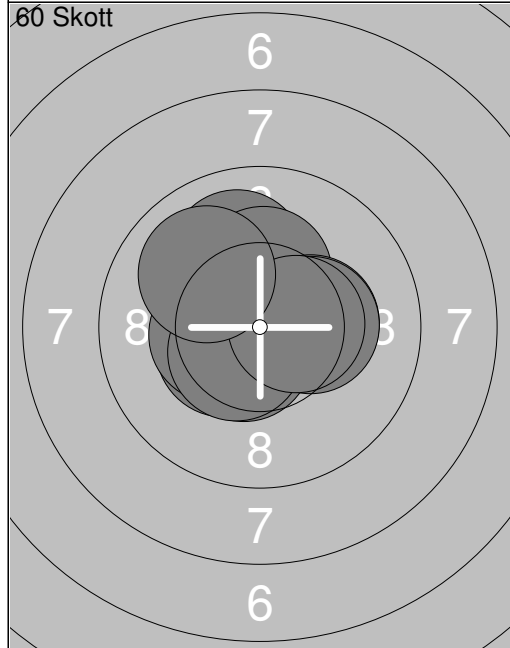

1:	10.0	↗
2:	10.6x	↘
3:	10.3x	↗
4:	10.4x	↙
5:	10.4x	↙
6:	10.5x	↙
7:	10.3x	↗
8:	10.3x	↗
9:	10.5x	↗
10:	10.0	↙
Serie	103.3	
Total	103.3	

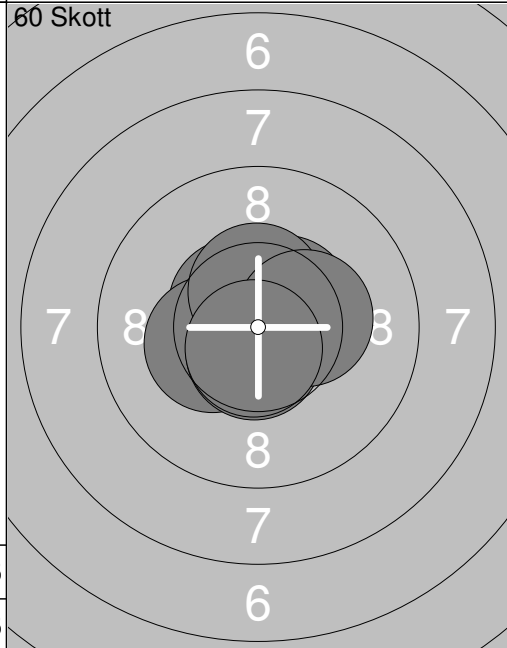

11:	10.6x	↙
12:	10.9x	↗
13:	10.8x	↙
14:	10.8x	↙
15:	10.5x	↙
16:	10.3x	↙
17:	10.6x	↘
18:	10.5x	↗
19:	10.3x	↗
20:	10.7x	↘
Serie	106.0	
Total	209.3	

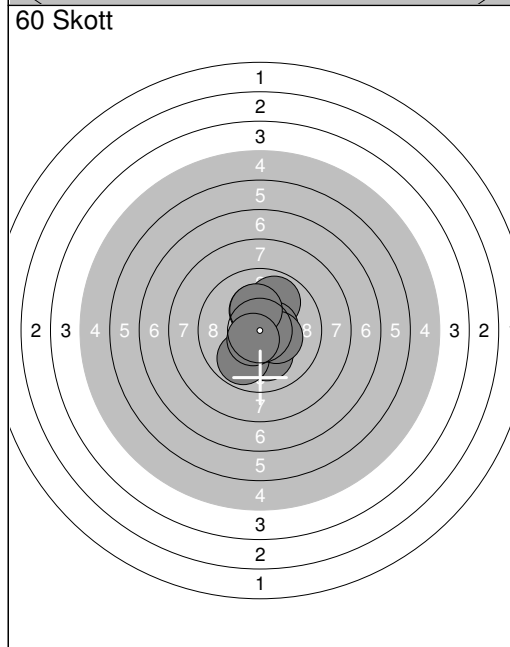

21:	10.1	↘
22:	9.8	↘
23:	10.6x	↗
24:	9.9	↗
25:	10.3x	↗
26:	10.5x	↗
27:	0.0	↓
28:	10.3x	↗
29:	10.2x	↗
30:	10.6x	↘
Serie	92.3	
Total	301.6	

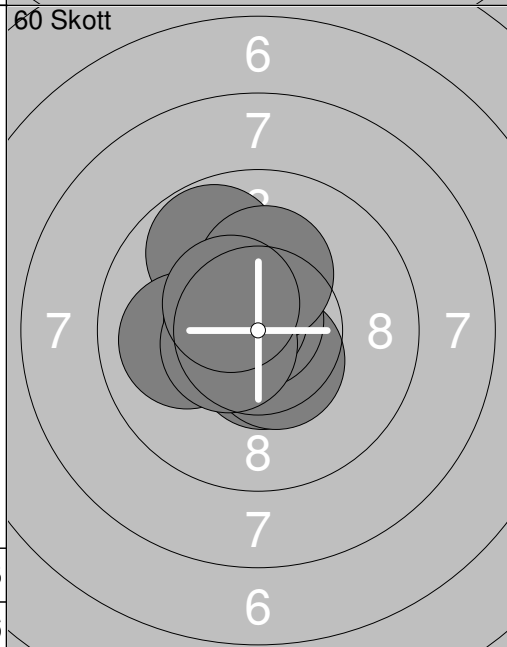

31:	9.8	↙
32:	10.0	↙
33:	10.6x	↙
34:	10.6x	↘
35:	10.5x	↘
36:	10.8x	↗
37:	10.6x	↙
38:	10.2x	↗
39:	10.5x	↙
40:	10.5x	↙
Serie	104.1	
Total	405.7	

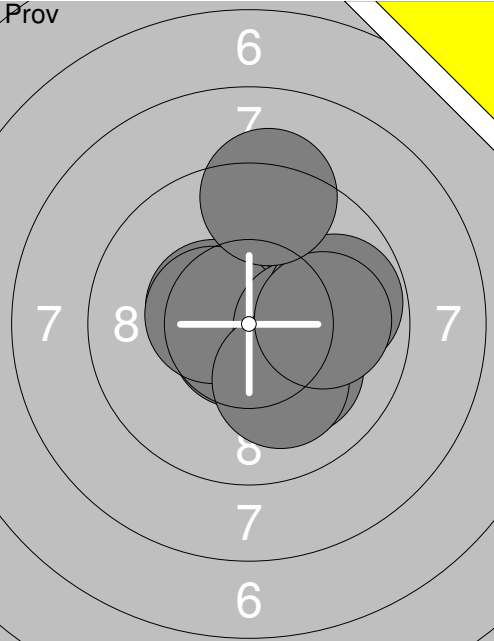
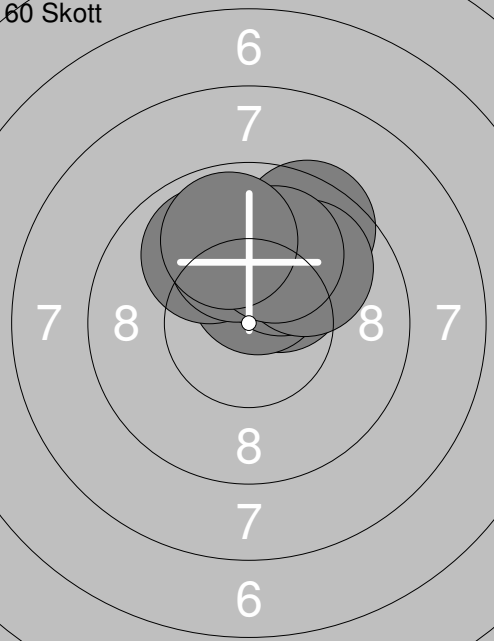
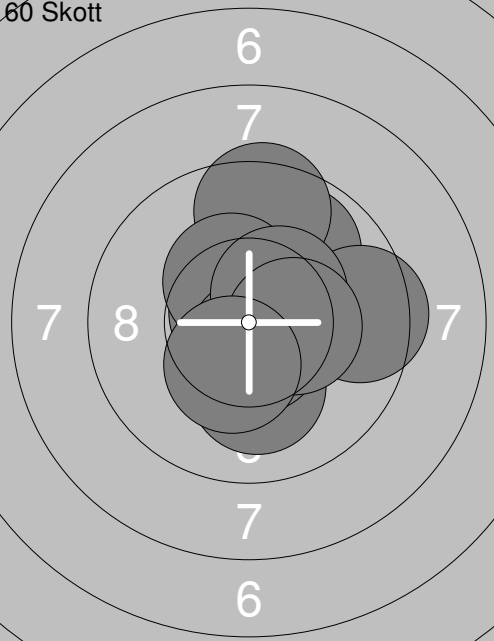
Skjuttag	Tavla	Jacob Hedman	
S	Umeå Skf		
08.04.2017	UMEKULAN 2017	Umeå skytteallians	
Prov		1: 10.6x ➤ 2: 10.1 ↘ 3: 10.7x ↘ 4: 10.4x ↘ 5: 10.5x ↘ 6: 10.3x ➤ 7: 10.1 ↘ 8: 9.8 ➔ 9: 10.0 ➔ 10: 9.3 ↑ Serie 101.8 Total 0.0	11: 10.9x ↘ 12: 9.3 ↗ 13: 10.5x ↘ 14: 10.5x ↘ 15: 10.4x ↘ 16: 10.7x ↗ Serie 62.3 Total 0.0
60 Skott		1: 10.3x ↗ 2: 9.5 ↗ 3: 10.5x ↗ 4: 10.1 ↗ 5: 10.0 ↑ 6: 9.9 ↗ 7: 9.9 ↘ 8: 10.0 ↑ 9: 10.0 ↗ 10: 9.8 ↑ Serie 100.0 Total 100.0	11: 9.6 ← 12: 10.0 ↗ 13: 9.7 ← 14: 10.6x ↘ 15: 10.2x ↗ 16: 10.1 ↗ 17: 10.5x ➤ 18: 10.1 ↘ 19: 10.2x ↘ 20: 9.8 ← Serie 100.8 Total 200.8
60 Skott		21: 9.9 ↗ 22: 9.5 ➔ 23: 10.8x ↘ 24: 9.5 ↑ 25: 10.1 ↘ 26: 10.4x ↗ 27: 10.6x ↘ 28: 10.4x ↗ 29: 10.4x ➤ 30: 10.4x ↘ Serie 102.0 Total 302.8	31: 10.6x ↘ 32: 10.7x ↗ 33: 10.3x ↗ 34: 9.7 ➔ 35: 10.6x ↘ 36: 10.4x ↗ 37: 10.5x ↘ 38: 10.2x ↘ 39: 10.7x ↘ 40: 10.6x ➤ Serie 104.3 Total 407.1

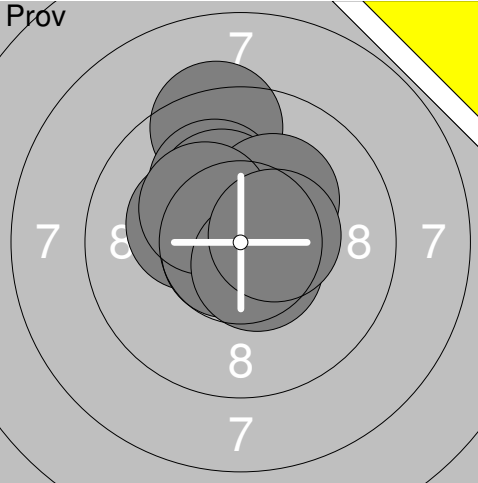
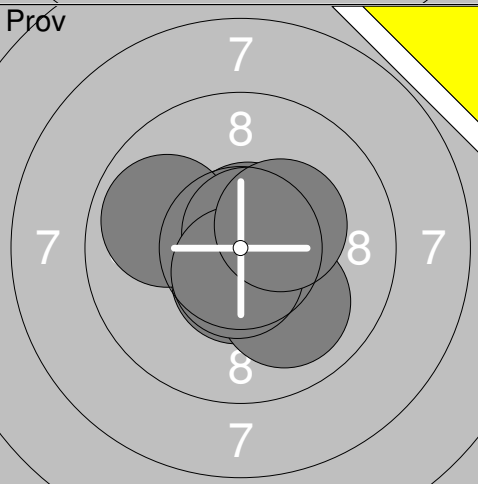
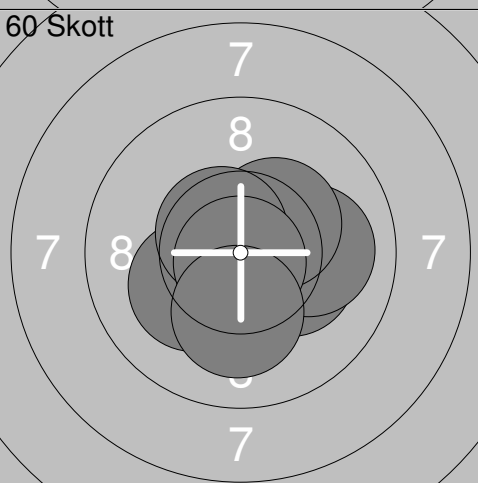
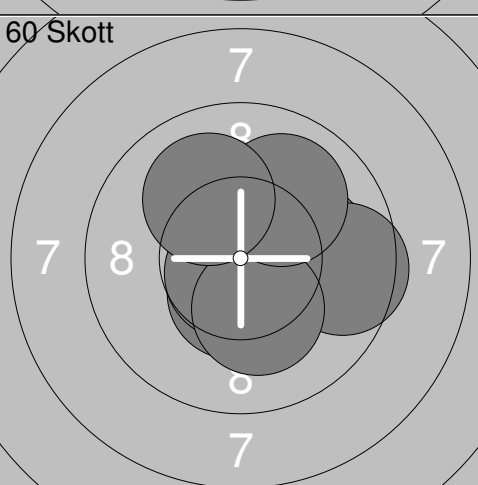
Skjutlag	Tavla	Mattias Lind		
1	16			
S	Skoga-Ekshärad Skf			
08.04.2017	UMEKULAN 2017	Umeå skytteallians		
Prov		1: 9.4 ↑ 2: 10.3x ↖ 3: 10.1 ↗ 4: 10.3x ↗ 5: 10.8x ↘ 6: 10.2x ↗ 7: 10.7x ↖ 8: 10.3x ↗ 9: 10.6x ↘ 10: 10.5x →	11: 10.5x ↘ 12: 10.1 ↖ 13: 10.7x ↗ 14: 10.3x ↖ 15: 10.1 ↗ 16: 10.7x ↗ 17: 10.3x ↘ 18: 10.3x ↘ 19: 10.4x ↘ 20: 10.7x ↖	
	Serie	103.2	Serie	104.1
	Total	0.0	Total	0.0
Prov		21: 10.5x ↘ 22: 10.7x ↗ 23: 9.9 ↖ 24: 10.7x ↗ 25: 10.0 ↘ 26: 10.6x ↘ 27: 10.3x ↗	60 Skott	1: 10.1 ↖ 2: 10.3x ↖ 3: 9.9 → 4: 9.8 ↑ 5: 10.0 ↗ 6: 10.8x → 7: 10.7x ↘ 8: 10.7x ↘ 9: 10.2x ↗ 10: 10.5x ↘
	Serie	72.7	Serie	103.0
	Total	0.0	Total	103.0
60 Skott		11: 10.8x ↖ 12: 10.6x ↖ 13: 10.4x → 14: 10.2x → 15: 10.0 → 16: 10.2x ↖ 17: 10.3x ↗ 18: 10.6x ↗ 19: 10.8x ↘ 20: 10.2x ↘	60 Skott	21: 10.8x ↖ 22: 10.8x ↑ 23: 10.5x → 24: 10.1 ↗ 25: 10.4x ↗ 26: 10.6x ↘ 27: 10.7x → 28: 10.1 ↑ 29: 10.1 ↑ 30: 10.2x ↗
	Serie	104.1	Serie	104.3
	Total	207.1	Total	311.4
60 Skott		31: 10.1 → 32: 10.5x ↘ 33: 10.5x ↘ 34: 10.4x ↗ 35: 10.9x ↘ 36: 9.6 → 37: 10.7x ↘ 38: 10.2x ↘ 39: 10.0 ↗ 40: 10.0 ↗		
	Serie	102.9		
	Total	414.3		

Prov 	Prov 	
1: 10.4x↙ 2: 10.6x↘ 3: 10.1 ↘ 4: 10.7x↘ 5: 10.4x↙ 6: 10.4x↗ 7: 10.4x➔ 8: 10.4x↗ 9: 10.6x➔ 10: 9.5 ➔	11: 10.1 ↖ 12: 10.5x➔ 13: 9.3 ↗ 14: 10.1 ➔ 15: 10.4x↗ 16: 10.1 ↗ 17: 10.7x↘	
Serie 103.5	Serie 71.2	
Total 0.0	Total 0.0	

60 Skott 	60 Skott 	
1: 10.2x➔ 2: 10.5x↙ 3: 10.2x↗ 4: 10.1 ➔ 5: 10.0 ↗ 6: 10.2x↙ 7: 10.3x↘ 8: 10.3x↘ 9: 9.9 ↘ 10: 10.3x↘	11: 9.9 ↘ 12: 10.4x↗ 13: 10.2x➔ 14: 10.8x↙ 15: 10.6x↗ 16: 10.5x➔ 17: 10.3x↙ 18: 9.8 ➔ 19: 10.6x↙ 20: 10.2x↗	
Serie 102.0	Serie 103.3	
Total 102.0	Total 205.3	

60 Skott 	60 Skott 	
21: 10.2x↗ 22: 10.3x↗ 23: 9.9 ➔ 24: 9.9 ➔ 25: 10.1 ↘ 26: 10.4x↘ 27: 10.3x➔ 28: 10.2x↙ 29: 10.3x↗ 30: 10.2x↗	31: 10.3x➔ 32: 9.6 ↘ 33: 10.3x➔ 34: 10.7x➔ 35: 10.6x↘ 36: 10.3x➔ 37: 10.5x↗ 38: 10.5x↘ 39: 10.6x↙ 40: 10.7x↙	
Serie 101.8	Serie 104.1	
Total 307.1	Total 411.2	

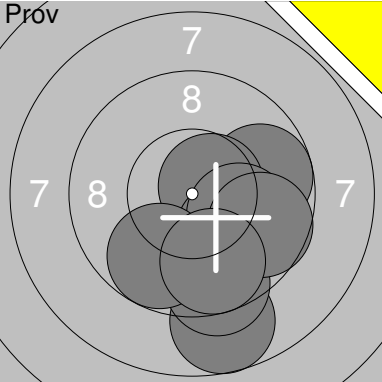
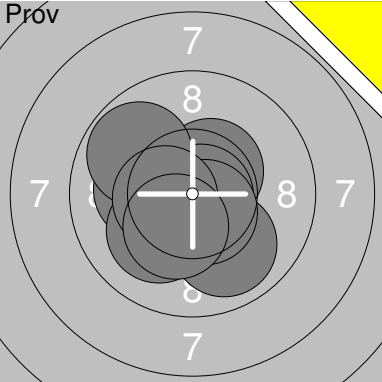
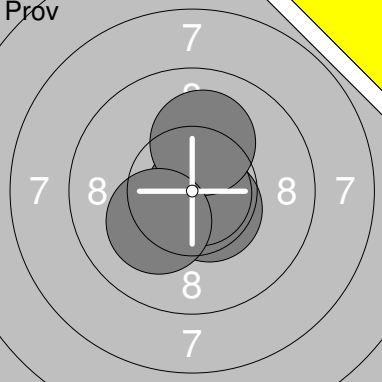
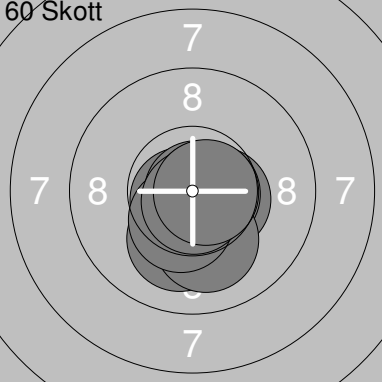
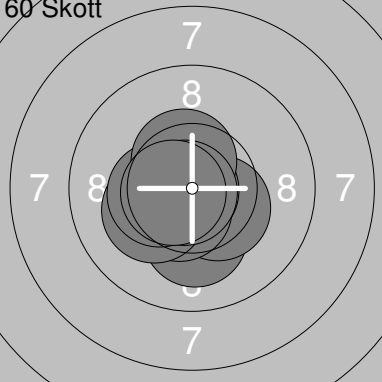
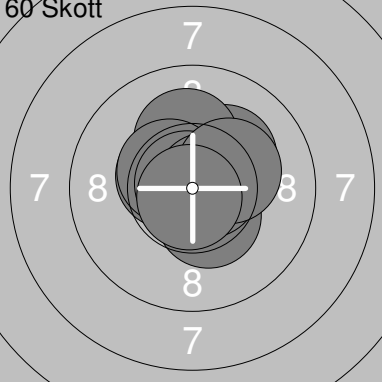
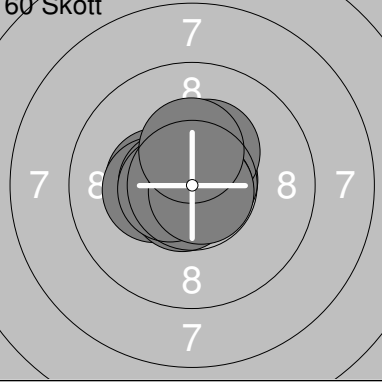
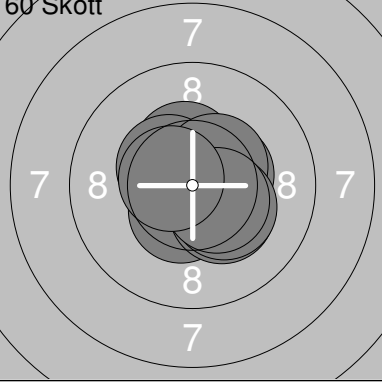
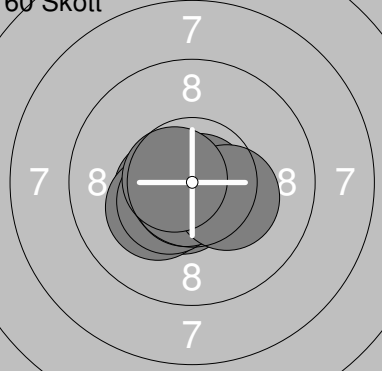
Skjutlag 1	Tavla 20	Ellinor Axelsson Vaughn			
S		Djurö Skf			
08.04.2017		UMEKULAN 2017		Umeå skytteallians	
Pröv		1: 8.7 ↓ 2: 9.4 ↓ 3: 9.8 → 4: 10.6x → 5: 10.0 ↓ 6: 9.9 ↓ 7: 10.1 ↓ 8: 9.7 ↓ 9: 9.8 ↓ 10: 9.8 ↓	Pröv		11: 10.0 ↓ 13: 10.5x ↗ 14: 10.2x ← 15: 10.8x → 16: 9.8 ↗ 17: 10.6x ↓ 18: 10.1 ↓ 19: 10.5x ← 20: 10.3x ↓
		Serie 97.8 Total 0.0			Serie 92.8 Total 0.0
Pröv		21: 10.6x ↓ 22: 10.5x ↓ 23: 10.8x → 24: 10.1 ↑ 25: 10.2x ↖	60 Skott		1: 10.1 ↓ 2: 10.7x ↖ 3: 10.9x → 4: 10.5x → 5: 10.7x → 6: 10.7x → 7: 10.1 ↓ 8: 10.4x ↓ 9: 10.8x ↓ 10: 10.7x →
		Serie 52.2 Total 0.0			Serie 105.6 Total 105.6
60 Skott		11: 10.6x ↓ 12: 10.2x ↓ 13: 10.4x ↓ 14: 10.8x ← 15: 10.5x ↓ 16: 10.2x ← 17: 10.4x ← 18: 10.5x ↑ 19: 10.8x ↖ 20: 10.6x ←	60 Skott		21: 10.2x ↗ 22: 10.5x ↖ 23: 10.4x ↓ 24: 10.7x ↗ 25: 10.1 ↑ 26: 10.5x ↗ 27: 10.8x ↗ 28: 10.7x → 29: 10.3x ↗ 30: 10.8x ↓
		Serie 105.0 Total 210.6			Serie 105.0 Total 315.6
60 Skott		31: 10.7x → 32: 10.4x ← 33: 10.3x ← 34: 10.3x ← 35: 10.6x ↖ 36: 10.8x ↖ 37: 10.7x ↖ 38: 10.6x ← 39: 10.8x ↖ 40: 10.4x ↑	60 Skott		41: 10.4x ↑ 42: 10.4x ↖ 43: 10.8x ↓ 44: 10.5x ↓ 45: 10.3x ↓ 46: 10.4x → 47: 10.4x ↗ 48: 10.3x ↓ 49: 10.5x ↓ 50: 10.6x ↖
		Serie 105.6 Total 421.2			Serie 104.6 Total 525.8
60 Skott		51: 10.5x ← 52: 10.7x ↓ 53: 10.9x ↓ 54: 10.6x ↓ 55: 10.2x ← 56: 10.8x → 57: 10.4x ↖ 58: 10.7x ↓ 59: 10.3x → 60: 10.6x ←			
		Serie 105.7 Total 631.5			

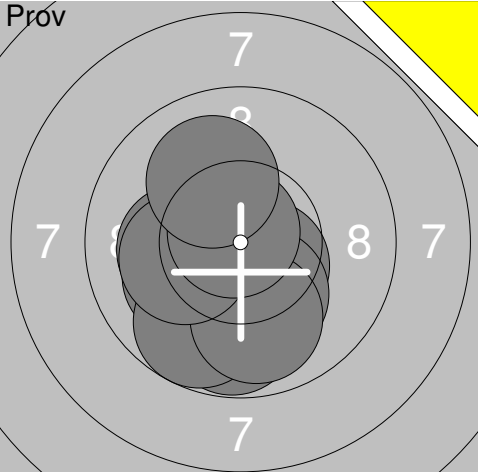
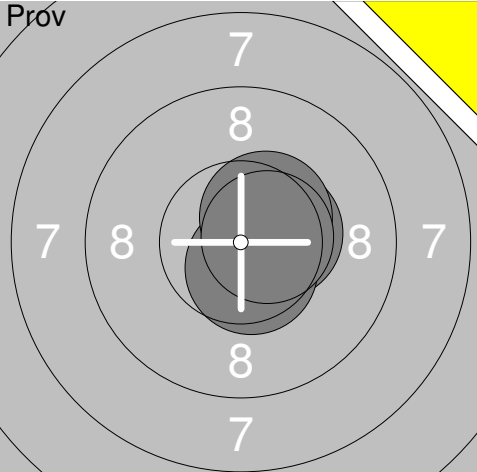
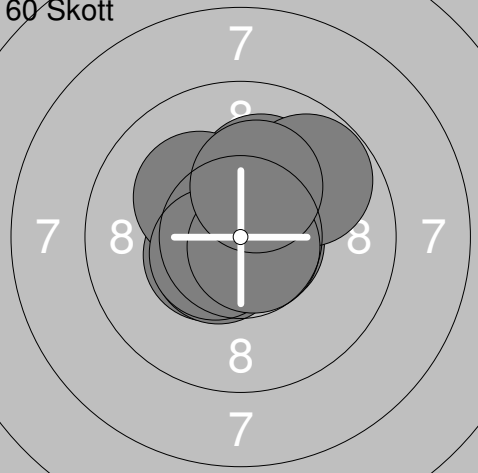
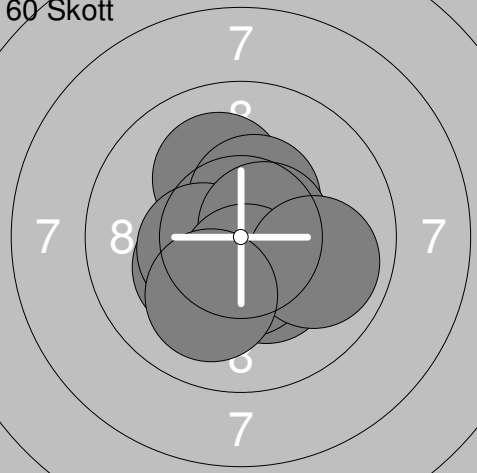
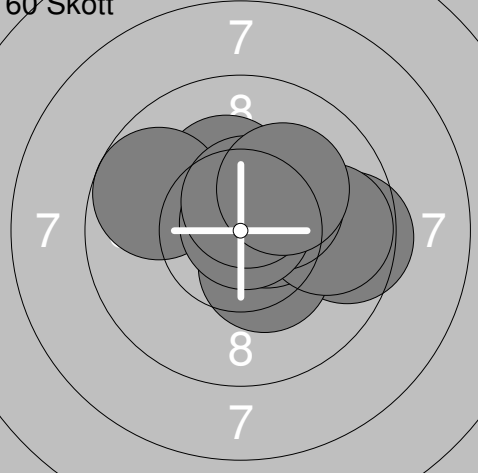
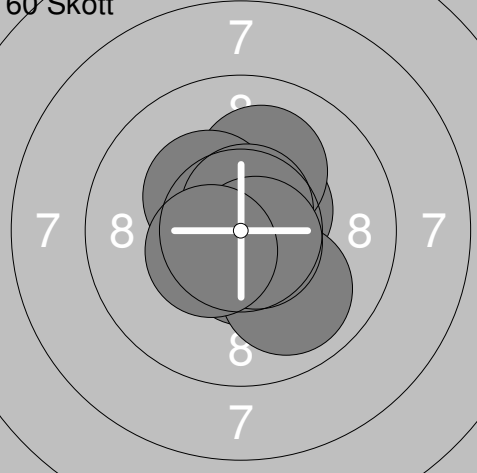
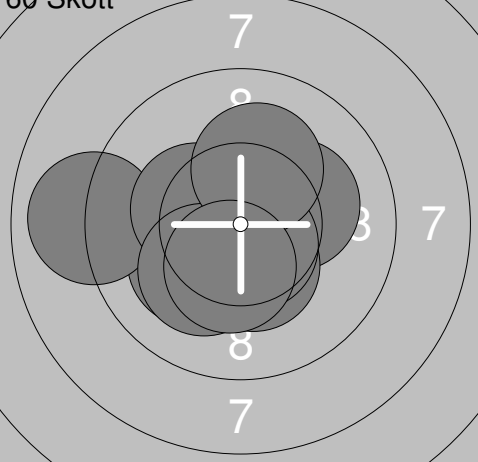
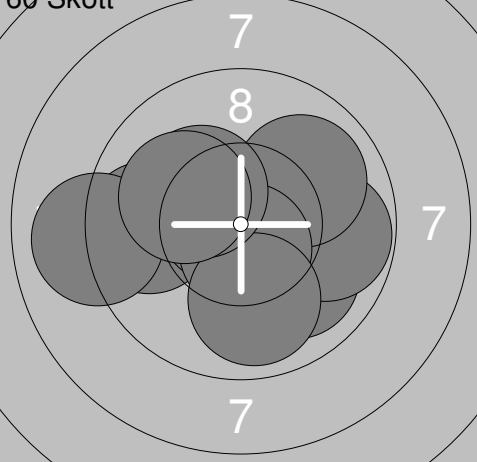
Skjutlag	Tavla	Markus-Pekka Dreyer Perkiömäki	
S	Umeå Skf		
08.04.2017	UMEKULAN 2017	Umeå skytteallians	
Pröv		1: 10.1 ↙ 2: 9.8 ↓ 3: 10.5x ↘ 4: 10.2x ↘ 5: 9.7 ↓ 6: 9.9 ↓ 7: 10.2x ← 8: 10.2x ← 9: 10.8x ↗ 10: 10.0 ↗ Serie 101.4 Total 0.0	Pröv  11: 10.5x → 12: 10.6x ↓ 13: 10.5x ↗ 14: 10.6x → Serie 42.2 Total 0.0
60 Skott		1: 10.5x ↙ 2: 10.5x ↙ 3: 10.1 ↗ 4: 10.5x ↗ 5: 10.7x → 6: 10.2x ↗ 7: 10.5x ↙ 8: 9.8 ↗ 9: 10.7x ↘ 10: 10.2x ↗ Serie 103.7 Total 103.7	60 Skott  11: 10.1 ↗ 12: 10.8x ← 13: 10.2x ↙ 14: 10.4x ↗ 15: 10.3x ↘ 16: 10.4x ← 17: 10.6x → 18: 10.5x ↓ 19: 9.9 → 20: 10.1 ↓ Serie 103.3 Total 207.0
60 Skott		21: 9.5 → 22: 10.4x ↘ 23: 10.6x → 24: 10.3x ↗ 25: 9.8 → 26: 9.7 ← 27: 10.3x ↗ 28: 10.8x ↗ 29: 10.5x ↗ 30: 10.1 ↗ Serie 102.0 Total 309.0	60 Skott  31: 10.5x ↗ 32: 10.1 ↗ 33: 10.3x ↗ 34: 10.8x ↘ 35: 10.5x ↘ 36: 10.6x ↘ 37: 10.7x ↗ 38: 10.0 ↘ 39: 10.7x ↘ 40: 10.5x ↙ Serie 104.7 Total 413.7
60 Skott		41: 10.2x → 42: 10.1 ↙ 43: 9.0 ← 44: 10.8x ↘ 45: 10.3x ← 46: 10.4x ↘ 47: 10.6x ↘ 48: 10.2x ↙ 49: 10.2x ↗ 50: 10.4x ↘ Serie 102.2 Total 515.9	60 Skott  51: 9.7 ← 52: 10.7x ← 53: 10.0 ↘ 54: 9.8 → 55: 10.0 ↗ 56: 10.6x ↘ 57: 9.0 ← 58: 9.9 ↘ 59: 10.3x ↗ 60: 10.1 ↗ Serie 100.1 Total 616.0

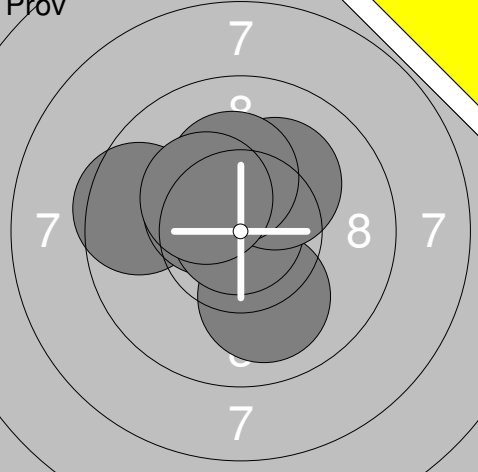
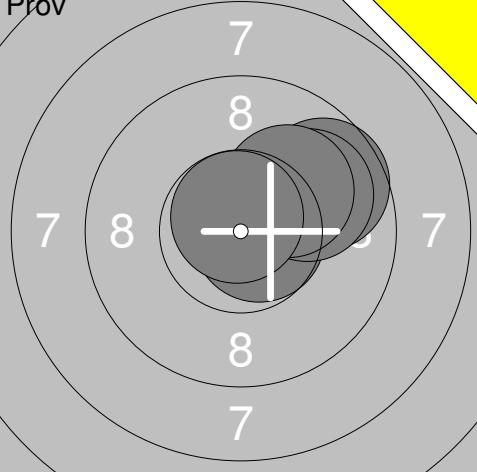
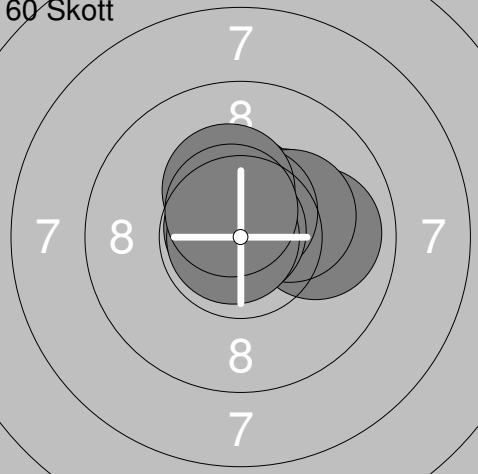
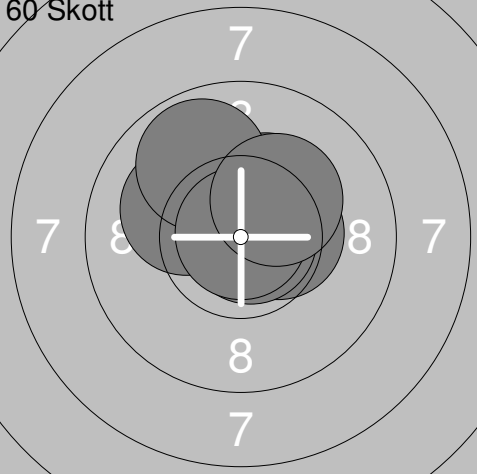
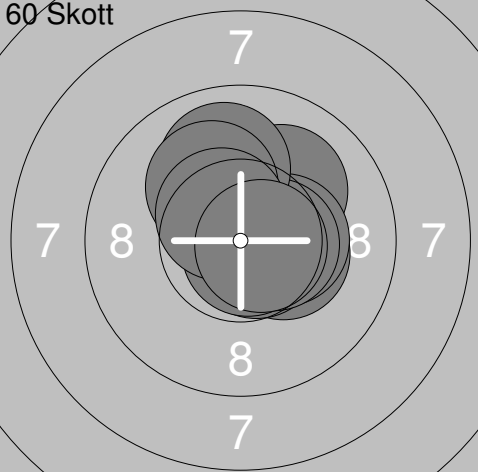
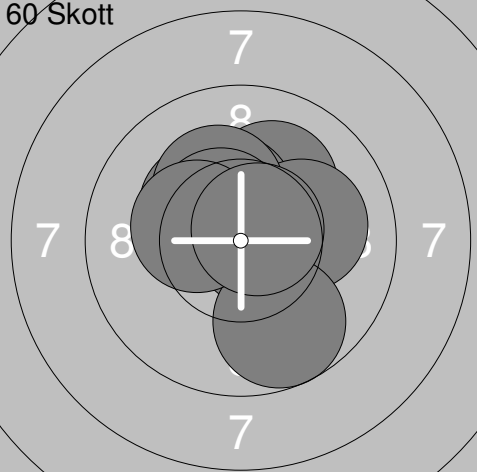
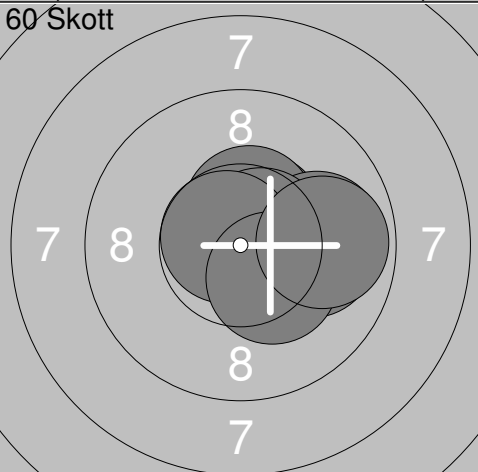
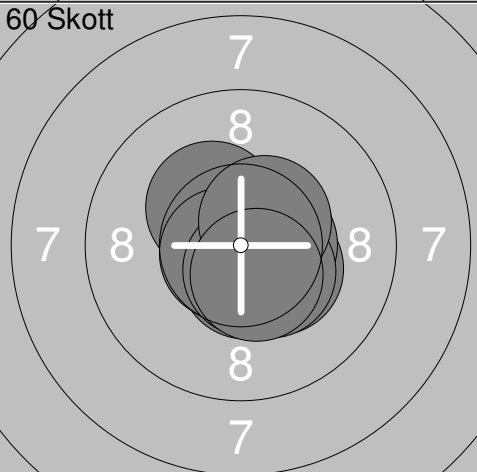
Pröv 	1: 10.7x ↗ 2: 10.8x ↑ 3: 10.0 ↓ 4: 9.5 ← 5: 10.4x ↗ 6: 10.4x ↗ 7: 10.9x ↗ 8: 10.2x ↗ 9: 10.2x ↑ 10: 10.3x ↗ <hr/> Serie 103.4 Total 0.0	Pröv 	11: 10.7x → 12: 9.7 ↗ 13: 9.9 ↗ 14: 10.1 ↗ 15: 10.7x ↑ <hr/> Serie 51.1 Total 0.0
60 Skott 	1: 10.5x ↑ 2: 9.9 → 3: 10.3x ↗ 4: 10.2x → 5: 10.6x ↑ 6: 10.9x ↑ 7: 10.3x ↑ 8: 10.8x ↗ 9: 10.8x ← 10: 10.6x ↗ <hr/> Serie 104.9 Total 104.9	60 Skott 	11: 10.7x ↗ 12: 10.6x ↗ 13: 10.5x → 14: 10.8x → 15: 10.3x ↑ 16: 10.3x ↗ 17: 10.1 ← 18: 9.8 ↑ 19: 10.9x ↑ 20: 10.3x ↗ <hr/> Serie 104.3 Total 209.2
60 Skott 	21: 10.3x → 22: 10.7x ↓ 23: 10.1 ↗ 24: 10.4x → 25: 10.5x → 26: 10.0 ↑ 27: 10.1 ↗ 28: 10.8x ↓ 29: 10.5x ↗ 30: 10.7x → <hr/> Serie 104.1 Total 313.3	60 Skott 	31: 10.1 ↗ 32: 10.4x ↑ 33: 10.7x → 34: 10.3x ↗ 35: 10.1 → 36: 10.2x ↗ 37: 9.7 ↓ 38: 10.5x ↗ 39: 10.3x ← 40: 10.7x ↗ <hr/> Serie 103.0 Total 416.3
60 Skott 	41: 10.3x → 42: 10.6x ↗ 43: 10.5x ↗ 44: 10.0 → 45: 10.5x ↑ 46: 9.9 → 47: 10.6x ↗ 48: 10.7x ↗ 49: 10.3x ↓ 50: 9.8 → <hr/> Serie 103.2 Total 519.5	60 Skott 	51: 10.5x ↗ 52: 10.6x ↓ 53: 10.4x ↓ 54: 10.3x ↗ 55: 10.5x → 56: 10.4x ↓ 57: 10.7x ← 58: 10.6x ↓ 59: 10.5x ↗ 60: 10.5x ↓ <hr/> Serie 105.0 Total 624.5

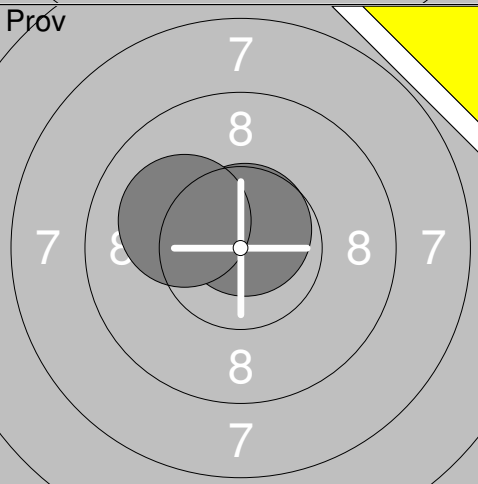
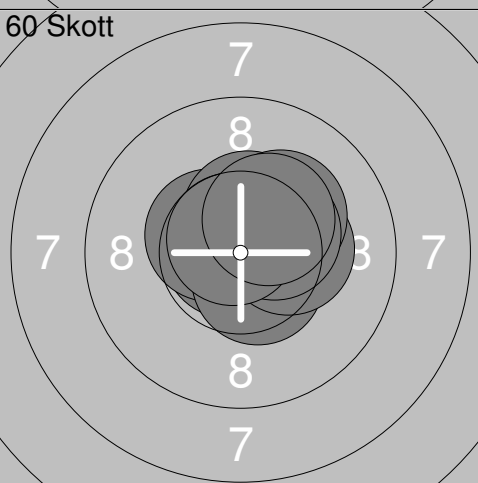
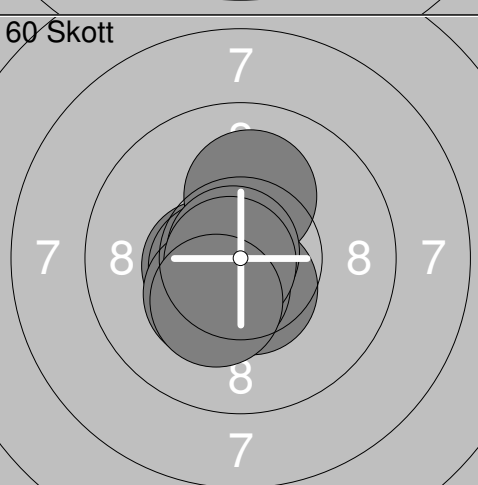
Skjutlag 1	Tavla 25	Jonathan B-Gustavsson		
S		Skoga-Ekshärad Skf		
08.04.2017		UMEKULAN 2017	Umeå skytteallians	
Prov		1: 10.0 ↓ 2: 10.3x ↓ 3: 10.6x ↓ 4: 10.4x ↓ 5: 10.0 ↓ 6: 9.6 ↓ 7: 10.2x ↓ 8: 10.7x ↗ 9: 10.7x ↓ 10: 10.2x ↙ Serie 102.7 Total 0.0	11: 9.9 ↙ 12: 10.3x ↗ 13: 10.0 → 14: 10.0 ↙ 15: 10.6x → 16: 10.3x → 17: 10.6x → 18: 10.4x ↗ 19: 10.4x ↗ 20: 10.4x ↙ Serie 102.9 Total 0.0	
Prov		21: 10.7x ↗ 22: 10.1 ↙ Serie 20.8 Total 0.0	60 Skott	1: 10.3x → 2: 10.2x ↙ 3: 10.7x ↗ 4: 10.6x ↗ 5: 10.8x ↙ 6: 10.5x ↓ 7: 9.8 ↙ 8: 10.6x ↓ 9: 10.5x ↓ 10: 10.0 → Serie 104.0 Total 104.0
60 Skott		11: 10.7x → 12: 10.8x ← 13: 10.5x ↗ 14: 10.5x ↓ 15: 10.5x ↗ 16: 10.3x → 17: 10.2x ↗ 18: 10.4x ↗ 19: 10.7x ↗ 20: 10.4x ↗ Serie 105.0 Total 209.0	60 Skott	21: 10.1 → 22: 10.6x ↙ 23: 10.3x ↙ 24: 10.5x ↗ 25: 10.7x ↙ 26: 10.4x ↗ 27: 10.5x ↗ 28: 10.4x ↗ 29: 10.5x ↓ 30: 10.8x ↗ Serie 104.8 Total 313.8
60 Skott		31: 10.6x ↓ 32: 10.5x ← 33: 10.5x ↓ 34: 10.6x ← 35: 10.5x ↓ 36: 10.1 ↗ 37: 10.3x ↙ 38: 10.8x ↗ 39: 10.8x ← 40: 10.3x ↙ Serie 105.0 Total 418.8		

<p>Prov</p>	<p>1: 9.5 ↘ 2: 10.2x↓ 3: 10.4x↓ 4: 10.6x↔ 5: 10.5x↓ 6: 10.4x↓ 7: 10.0→ 8: 10.7x→ 9: 10.7x↔ 10: 10.7x↔</p> <p>Serie 103.7 Total 0.0</p>	<p>Prov</p>	<p>11: 10.8x↓</p> <p>Serie 10.8 Total 0.0</p>
<p>60 Skott</p>	<p>1: 10.7x↑ 2: 10.3x↔ 3: 10.6x↑ 4: 10.8x↓ 5: 10.5x→ 6: 10.5x↓ 7: 10.3x↓ 8: 10.8x↑ 9: 10.7x↑ 10: 10.5x→</p> <p>Serie 105.7 Total 105.7</p>	<p>60 Skott</p>	<p>11: 10.7x↔ 12: 10.3x↔ 13: 10.6x↔ 14: 10.3x↑ 15: 10.6x↗ 16: 10.2x→ 17: 10.7x↓ 18: 10.6x↓ 19: 10.9x↔ 20: 10.5x↑</p> <p>Serie 105.4 Total 211.1</p>
<p>60 Skott</p>	<p>21: 10.4x↓ 22: 10.8x→ 23: 10.6x↓ 24: 10.3x↔ 25: 10.5x↔ 26: 10.5x↑ 27: 10.8x↓ 28: 10.9x↔ 29: 10.9x↓ 30: 10.4x↔</p> <p>Serie 106.1 Total 317.2</p>	<p>60 Skott</p>	<p>31: 10.5x↓ 32: 10.3x↑ 33: 10.8x↑ 34: 10.3x↔ 35: 10.5x↔ 36: 10.3x↔ 37: 10.7x↔ 38: 10.8x↑ 39: 9.7 ↑ 40: 10.3x↓</p> <p>Serie 104.2 Total 421.4</p>

Skjutlag 1	Tavla 27	Anton Lind	
S		Skoga-Ekshärad Skf	
08.04.2017		UMEKULAN 2017	Umeå skytteallians
Pröv 	1: 10.4x ↘ 2: 10.0 ↓ 3: 10.6x ← 4: 10.7x ↘ 5: 10.5x ↓ 6: 10.5x ↙ 7: 10.7x → 8: 10.1 ↓ 9: 10.4x ↓ 10: 10.6x ↙ Serie 104.5 Total 0.0	Pröv 	11: 10.8x ↙ 12: 10.3x ↗ 13: 10.2x ↙ 14: 10.5x ↗ 15: 10.2x ← 16: 10.1 ← Serie 62.1 Total 0.0
60 Skott 	1: 10.2x ← 2: 10.0 ↙ 3: 10.4x ↓ 4: 10.3x ↗ 5: 10.8x ← 6: 10.5x ↑ 7: 10.8x ↙ 8: 10.8x ↗ 9: 9.8 ↓ 10: 10.8x ↘ Serie 104.4 Total 104.4	60 Skott 	11: 10.0 → 12: 10.5x ↓ 13: 10.7x → 14: 10.7x → 15: 9.9 ↓ 16: 10.2x ↓ 17: 10.2x ↙ 18: 10.6x ↗ 19: 10.6x ↓ 20: 10.1 → Serie 103.5 Total 207.9
60 Skott 	21: 10.3x ↓ 22: 10.6x ↓ 23: 10.0 ↑ 24: 10.5x ↙ 25: 10.3x ↓ 26: 10.5x ↓ 27: 10.9x ↓ 28: 9.7 ↓ 29: 10.2x ↓ 30: 10.4x ↓ Serie 103.4 Total 311.3	60 Skott 	31: 10.5x ↓ 32: 10.6x ↙ 33: 10.2x ↓ 34: 10.4x ↗ 35: 10.7x → 36: 10.5x → 37: 10.6x → 38: 10.7x ↙ 39: 10.6x → 40: 10.7x ↗ Serie 105.5 Total 416.8
60 Skott 	41: 0.0 ↓ Serie 0.0 Total 416.8		

Skjutlag 1	Tavla 29	Hanna Augustsson	
S		Vännäs Skf	
08.04.2017		UMEKULAN 2017	Umeå skytteallians
Pröv 	1: 10.5x ↙ 2: 9.9 ↙ 3: 10.5x → 4: 10.7x ↗ 5: 10.8x ↙ 6: 10.5x ↙ 7: 10.6x ↙ 8: 10.6x ↙ 9: 10.3x ↙ 10: 10.6x ↙	Pröv 	11: 10.6x → 12: 10.5x ↖ 13: 10.5x ↓ 14: 10.4x → 15: 10.6x ↑ 16: 10.3x ↓ 17: 10.3x ↓ 18: 10.4x ↘ 19: 10.8x ↓ 20: 10.5x ↖
Serie 105.0		Serie 104.9	
Total 0.0		Total 0.0	
Pröv 	21: 10.4x ↗ 22: 10.3x ↙ 23: 10.5x →	60 Skott 	1: 10.8x → 2: 10.6x ↙ 3: 10.5x ↑ 4: 10.8x ← 5: 10.3x → 6: 10.9x ↓ 7: 10.3x → 8: 10.1 ↗ 9: 10.4x → 10: 10.7x ←
Serie 31.2		Serie 105.4	
Total 0.0		Total 105.4	
60 Skott 	11: 10.7x ↗ 12: 10.8x ↙ 13: 10.8x → 14: 10.4x ↓ 15: 10.6x ↓ 16: 10.3x ↙ 17: 10.3x ← 18: 10.8x → 19: 10.6x ↗ 20: 10.5x →	60 Skott 	21: 10.0 ↗ 22: 10.6x → 23: 10.3x ↗ 24: 10.7x ↙ 25: 10.1 ↓ 26: 10.6x ↗ 27: 10.6x ↙ 28: 10.4x ↙ 29: 10.5x ↗ 30: 10.2x ←
Serie 105.8		Serie 104.0	
Total 211.2		Total 315.2	
60 Skott 	31: 9.9 → 32: 10.5x ↙ 33: 10.9x ↙ 34: 10.6x ↗ 35: 10.8x ← 36: 10.5x ↗ 37: 10.4x ← 38: 10.6x ↗ 39: 10.7x ↗ 40: 10.5x ↙		
Serie 105.4			
Total 420.6			

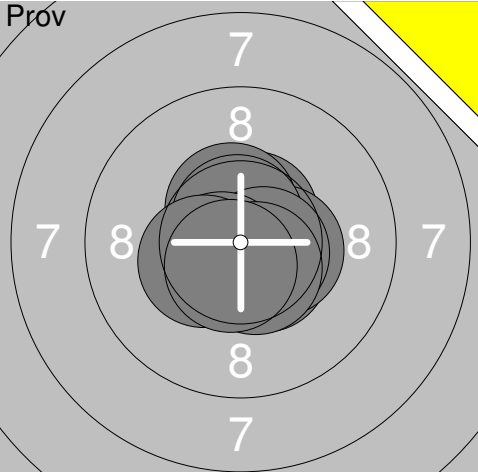
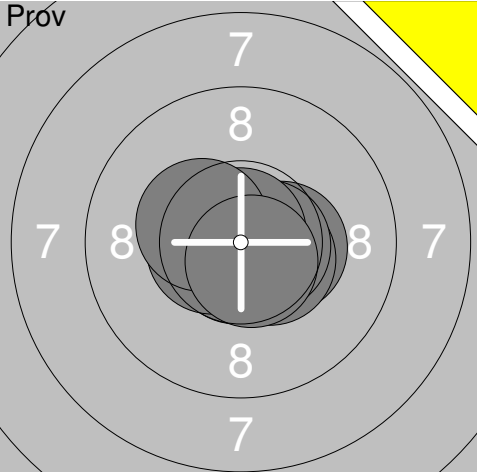
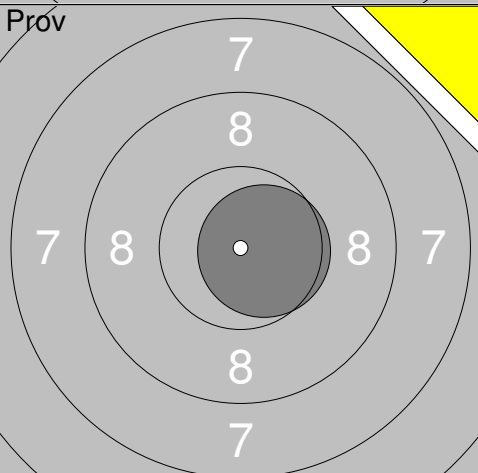
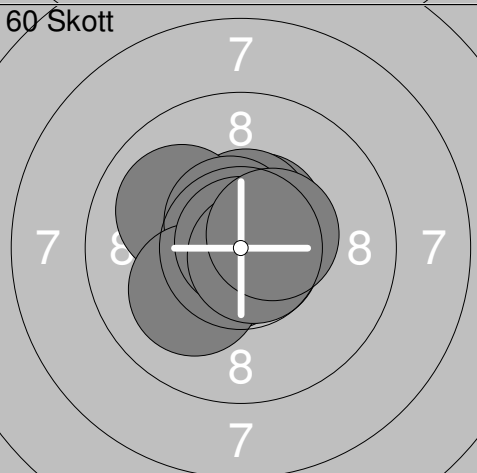
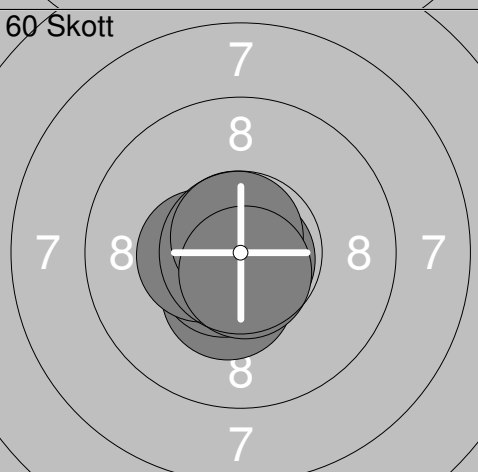
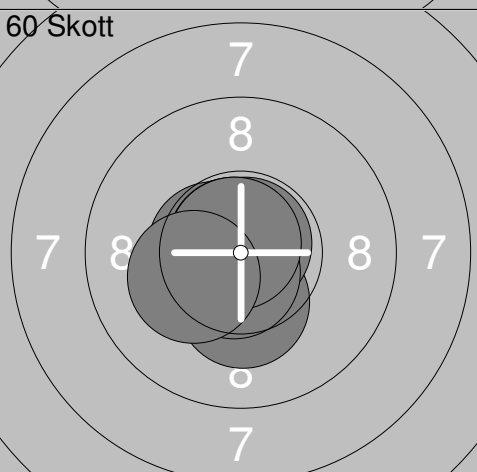
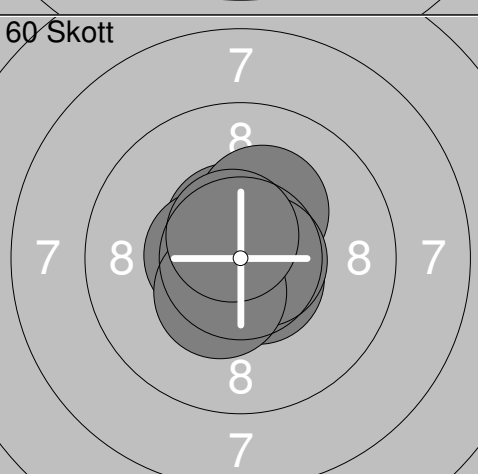
Skjutlag 1	Tavla 30	Joel Bergqvist	
S		Umeå Skf	
08.04.2017		UMEKULAN 2017	
Umeå skytteallians			
Pröv 	1: 10.6x ↗ 2: 10.5x ↘ 3: 10.5x ↗ 4: 10.4x → 5: 10.7x ↗ 6: 10.6x ↘ 7: 10.6x ↙ 8: 10.5x ↘ 9: 10.4x ↙ 10: 10.6x ↘ Serie 105.4 Total 0.0	Pröv 	11: 10.7x ↘ 12: 10.7x ↘ 13: 10.8x ↘ 14: 10.4x → 15: 10.5x ↘ 16: 10.6x → 17: 10.8x ↗ 18: 10.6x ← 19: 10.4x ↙ 20: 10.7x ↘ Serie 106.2 Total 0.0
Pröv 	21: 10.6x → Serie 10.6 Total 0.0	60 Skott 	1: 10.5x ↗ 2: 10.5x ↗ 3: 10.7x ↘ 4: 10.0 ↖ 5: 10.8x ↗ 6: 10.6x ↗ 7: 10.1 ↙ 8: 10.9x ↗ 9: 10.7x ↘ 10: 10.5x → Serie 105.3 Total 105.3
60 Skott 	11: 10.7x ← 12: 10.8x ← 13: 10.8x ↗ 14: 10.4x ↘ 15: 10.9x ↘ 16: 10.6x ↘ 17: 10.4x ← 18: 10.8x ↘ 19: 10.7x ↗ 20: 10.7x ↘ Serie 106.8 Total 212.1	60 Skott 	21: 10.5x ← 22: 10.7x ↖ 23: 10.7x ← 24: 10.6x ← 25: 10.3x ↓ 26: 10.8x ↗ 27: 10.8x ↗ 28: 10.7x ↘ 29: 10.8x ↗ 30: 10.2x ↖ Serie 106.1 Total 318.2
60 Skott 	31: 10.6x ↘ 32: 10.5x ↗ 33: 10.5x ← 34: 10.7x ↗ 35: 10.6x ↘ 36: 10.8x ↗ 37: 10.2x ↗ 38: 10.7x → 39: 10.4x ↘ 40: 10.6x ↗ Serie 105.6 Total 423.8		

<p>Prov</p>	<p>1: 10.4x ↘ 2: 10.1 ↓ 3: 9.7 → 4: 10.1 → 5: 10.2x ↓ 6: 10.7x ↘ 7: 10.8x ↗ 8: 10.7x → 9: 10.5x ↗ 10: 10.7x ↘</p> <p>Serie 103.9 Total 0.0</p>	<p>Prov</p>	<p>11: 10.4x ↘ 12: 10.2x ↘ 13: 10.9x ↘ 14: 10.4x ↘</p> <p>Serie 41.9 Total 0.0</p>
<p>60 Skott</p>	<p>1: 10.8x ↘ 2: 10.8x ↘ 3: 10.7x ↗ 4: 10.2x ↗ 5: 10.5x ↓ 6: 10.6x → 7: 10.7x → 8: 10.7x ↓ 9: 10.6x ↓ 10: 10.6x ↓</p> <p>Serie 106.2 Total 106.2</p>	<p>60 Skott</p>	<p>11: 10.7x → 12: 10.6x → 13: 10.4x → 14: 10.7x ↓ 15: 10.4x ↘ 16: 10.5x ↘ 17: 10.4x ↘ 18: 10.4x ↘ 19: 10.6x ↗ 20: 10.8x ↘</p> <p>Serie 105.5 Total 211.7</p>
<p>60 Skott</p>	<p>21: 10.7x ↘ 22: 10.6x ↗ 23: 10.7x ↗ 24: 10.7x ↓ 25: 10.7x ↘ 26: 10.8x ↘ 27: 10.6x ↘ 28: 10.7x ↗ 29: 10.8x ↗ 30: 10.7x ↗</p> <p>Serie 107.0 Total 318.7</p>	<p>60 Skott</p>	<p>31: 10.1 ↑ 32: 10.1 ↑ 33: 10.6x → 34: 10.8x ↘ 35: 10.8x → 36: 10.2x ↓ 37: 10.7x ↓ 38: 10.5x → 39: 10.1 ↓ 40: 10.7x ↘</p> <p>Serie 104.6 Total 423.3</p>

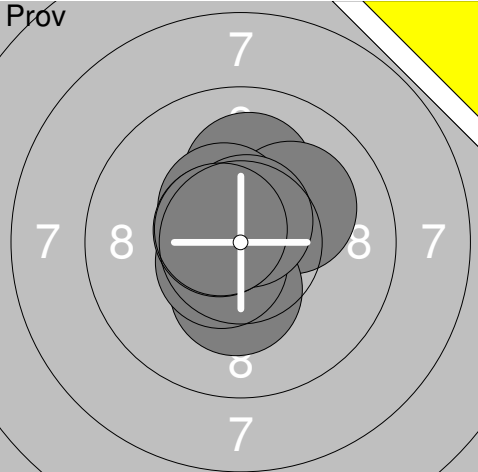
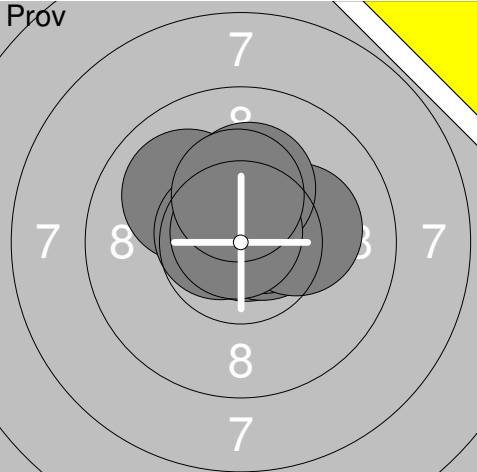
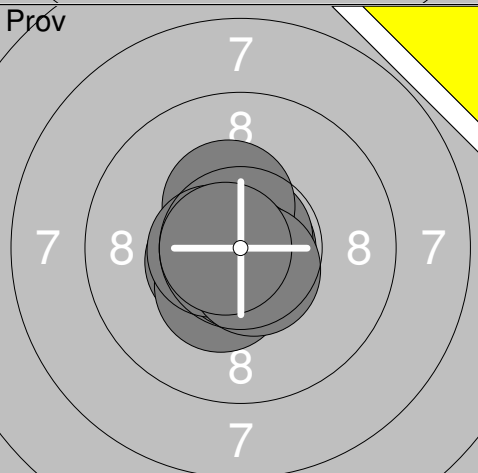
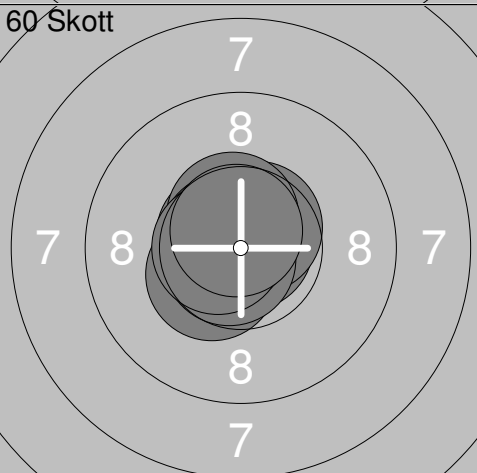
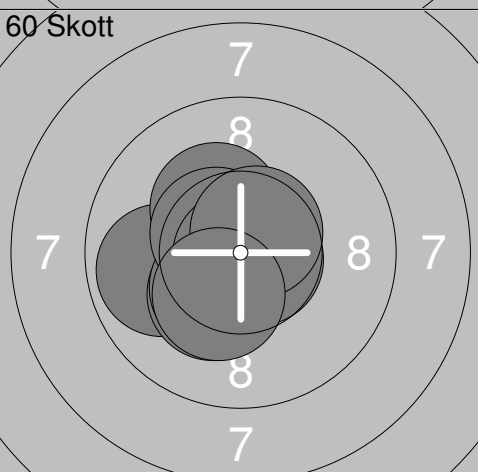
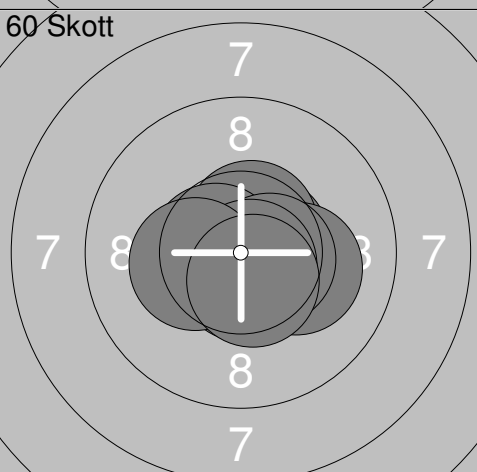
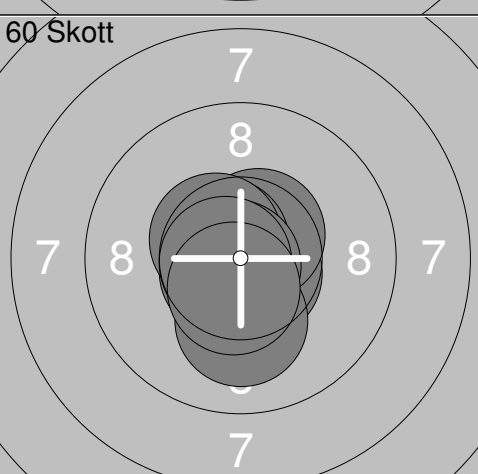
Skjutlag 1	Tavla 32	Jordan Olsson	
S		Umeå Skf	
08.04.2017		UMEKULAN 2017	
Umeå skytteallians			
Pröv 	1: 10.5x ↑ 2: 10.1 ↑ 3: 10.1 → 4: 10.4x ↖ 5: 10.8x ↑ 6: 10.3x ↓ 7: 10.6x ↙ 8: 10.7x ↑ 9: 10.6x ↖ 10: 10.6x ↖ Serie 104.7 Total 0.0	Pröv 	11: 10.8x ↗ 12: 10.6x → 13: 10.4x ↑ 14: 10.6x ↗ 15: 10.2x → 16: 10.0 ↖ 17: 10.2x ↑ 18: 10.6x ↖ 19: 10.8x ↑ 20: 10.3x ↑ Serie 104.5 Total 0.0
Pröv 	21: 10.5x ↖ 22: 10.4x ↙ 23: 10.9x ↙ 24: 10.8x → 25: 10.8x ↗ 26: 10.4x ↗ 27: 10.7x ↓ 28: 10.6x ← 29: 10.6x ↙ 30: 10.7x ← Serie 106.4 Total 0.0	60 Skott 	1: 10.8x ↗ 2: 10.6x ↗ 3: 10.4x ↖ 4: 10.7x ← 5: 10.7x ↖ 6: 10.5x ↑ 7: 10.7x ↙ 8: 10.7x ↖ 9: 10.6x ← 10: 10.7x ↑ Serie 106.4 Total 106.4
60 Skott 	11: 9.9 ← 12: 10.3x ↙ 13: 10.6x ↗ 14: 10.3x ↗ 15: 10.4x ↙ 16: 10.5x ↗ 17: 10.9x ↙ 18: 10.7x → 19: 10.6x ↗ 20: 10.3x ↙ Serie 104.5 Total 210.9	60 Skott 	21: 10.6x ↙ 22: 10.6x → 23: 10.6x ↑ 24: 10.6x ← 25: 10.2x → 26: 10.6x → 27: 10.6x ↓ 28: 10.7x ↙ 29: 10.3x ← 30: 10.5x ↙ Serie 105.3 Total 316.2
60 Skott 	31: 10.7x ↖ 32: 10.7x ↙ 33: 10.7x ↑ 34: 10.6x ↗ 35: 10.6x ↗ 36: 10.5x ↗ 37: 10.8x ↙ 38: 10.7x ← 39: 10.1 ↓ 40: 10.5x ↙ Serie 105.9 Total 422.1		

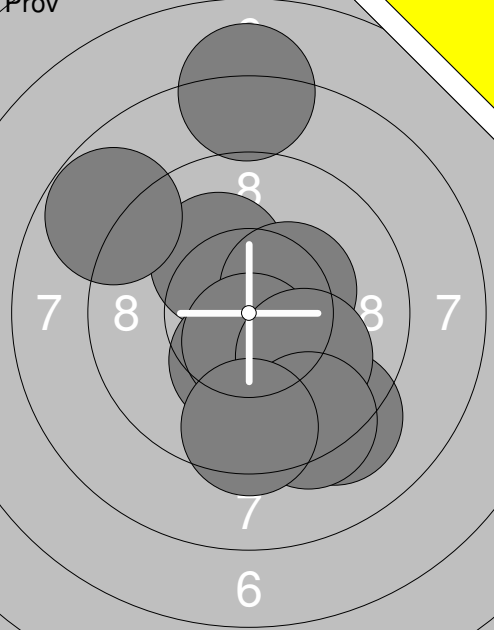
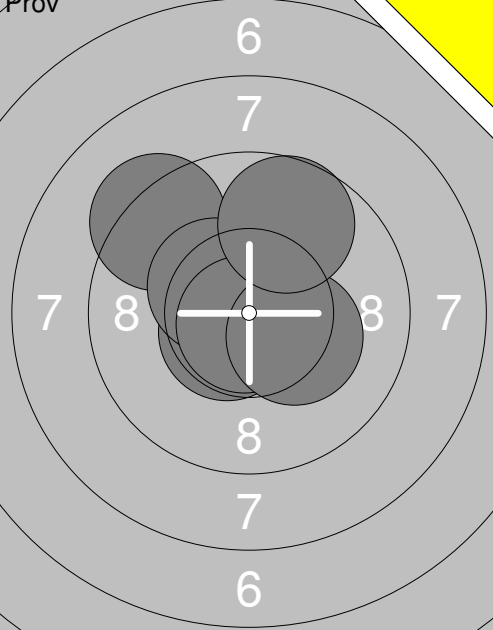
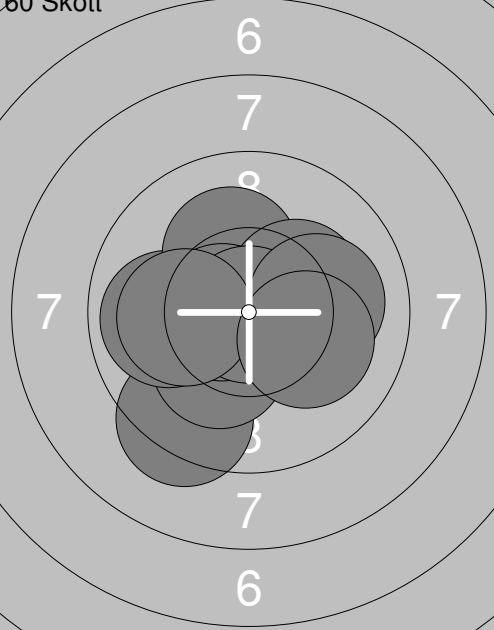
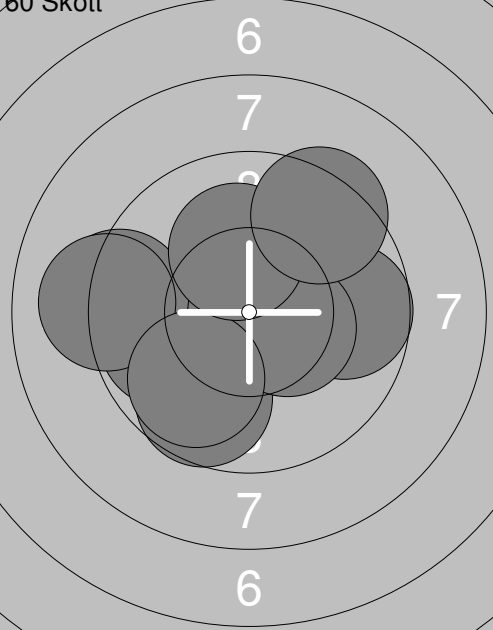
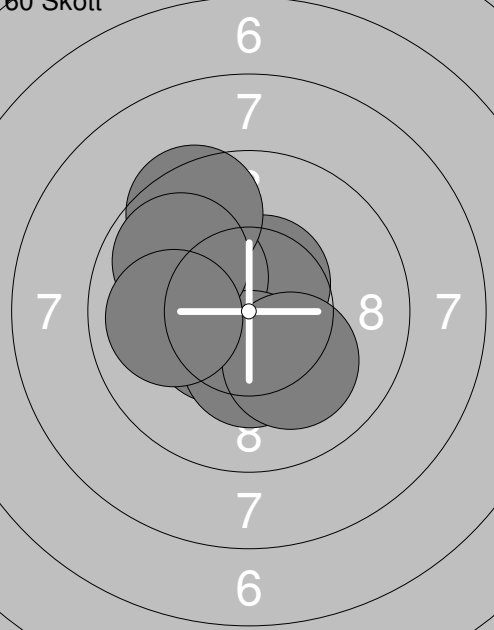
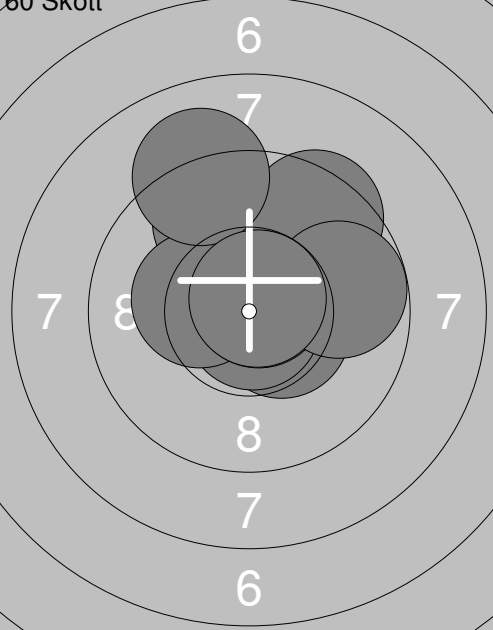
<p>Prov</p> 	<p>1: 10.2x ↘ 2: 10.4x ↗ 3: 8.1 ↑ 4: 9.2 ↘ 5: 10.3x ↘ 6: 8.8 ↖ 7: 10.6x ↘ 8: 10.0 ↘ 9: 9.4 ↘ 10: 9.5 ↘</p> <p>Serie 96.5 Total 0.0</p>	<p>Prov</p> 	<p>11: 10.6x ↘ 12: 9.3 ↖ 13: 10.4x ↘ 14: 10.8x ↘ 15: 10.3x ↘ 16: 9.7 ↗</p> <p>Serie 61.1 Total 0.0</p>
<p>60 Skott</p> 	<p>1: 9.3 ↘ 2: 10.2x ↘ 3: 9.9 ← 4: 10.2x ↗ 5: 10.3x ↗ 6: 10.6x ← 7: 10.9x ↘ 8: 10.1 ← 9: 10.1 → 10: 10.1 →</p> <p>Serie 101.7 Total 101.7</p>	<p>60 Skott</p> 	<p>11: 9.8 ← 12: 9.7 → 13: 10.5x ↘ 14: 9.3 ← 15: 9.1 ← 16: 9.7 ↘ 17: 10.4x ↘ 18: 9.8 ↘ 19: 10.1 ↗ 20: 9.4 ↗</p> <p>Serie 97.8 Total 199.5</p>
<p>60 Skott</p> 	<p>21: 10.7x ↘ 22: 9.8 ↖ 23: 10.5x ↘ 24: 10.5x ↗ 25: 10.2x ↘ 26: 10.3x ↘ 27: 9.5 ↗ 28: 10.1 ↘ 29: 9.8 ↖ 30: 10.0 ←</p> <p>Serie 101.4 Total 300.9</p>	<p>60 Skott</p> 	<p>31: 10.5x ↘ 32: 10.6x ↗ 33: 9.7 ↗ 34: 10.8x ↘ 35: 10.3x ← 36: 9.5 ↗ 37: 10.7x ↗ 38: 9.8 → 39: 9.1 ↗ 40: 10.7x ↗</p> <p>Serie 101.7 Total 402.6</p>

Prov 	1: 2.1 ← 2: 0.0 ← 3: 0.0 ← 4: 5.8 ← 5: 7.3 ← 6: 9.1 ↓ 7: 8.6 ← 8: 9.8 ↓ 9: 10.2x ← 10: 10.5x → Serie 63.4 Total 0.0	Prov 	11: 10.1 → 12: 10.0 → 13: 9.8 → 14: 10.5x ← 16: 9.5 ↓ Serie 49.9 Total 0.0
----------	--	----------	--

60 Skott 	1: 10.3x ↓ 2: 9.8 ← 3: 9.7 ↗ 4: 10.5x ↓ 5: 10.1 ← 6: 9.8 ← 7: 10.1 ↗ 8: 0.0 ↓ 9: 9.8 ↓ 10: 9.1 → Serie 89.2 Total 89.2	60 Skott 	11: 8.1 ← 12: 10.1 ↓ 13: 10.0 ← 14: 10.6x ↗ 15: 9.5 ↓ 16: 10.7x ↓ 17: 10.8x ↗ 18: 10.2x ↓ 19: 10.8x ↓ 20: 0.0 → Serie 90.8 Total 180.0
--------------	---	--------------	---

60 Skott 	21: 10.4x ↓ 22: 10.4x ↓ 23: 10.0 ↗ 24: 10.2x ↓ 25: 10.0 ← 26: 9.0 → 27: 10.1 ← 28: 10.0 ↓ 29: 9.1 → 30: 9.9 ↓ Serie 99.1 Total 279.1	60 Skott 	31: 9.8 ← 32: 10.6x ↓ 33: 9.8 ↓ 34: 10.5x ↓ 35: 10.3x ↗ 36: 9.2 → 37: 10.7x ↓ 38: 9.5 → 39: 10.3x ↗ 40: 9.1 ↑ Serie 99.8 Total 378.9
--------------	---	--------------	---

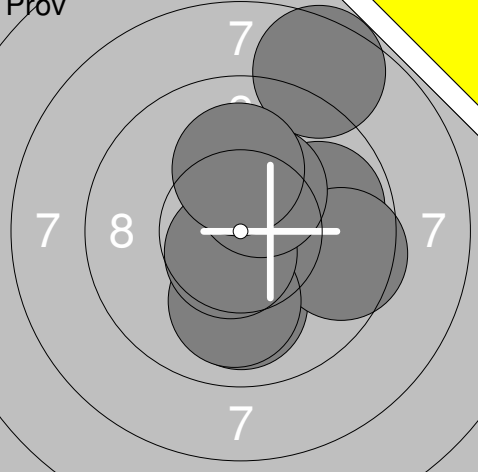
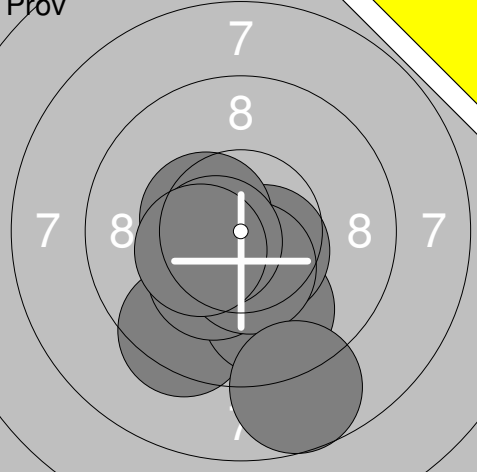
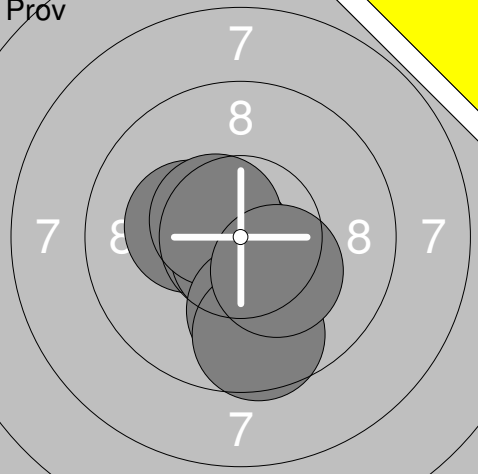
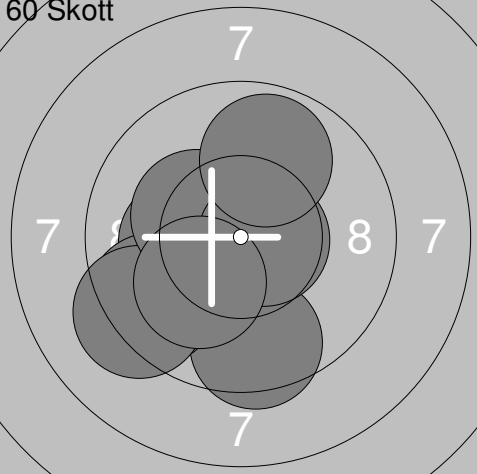
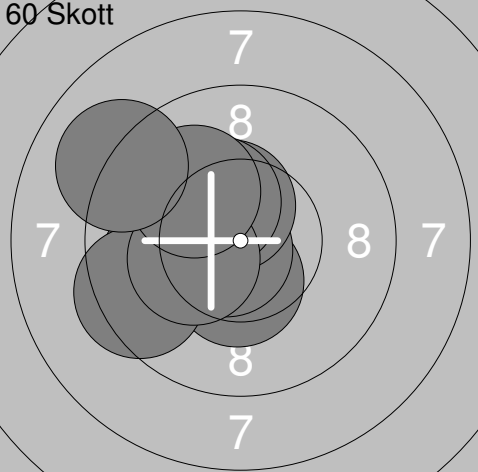
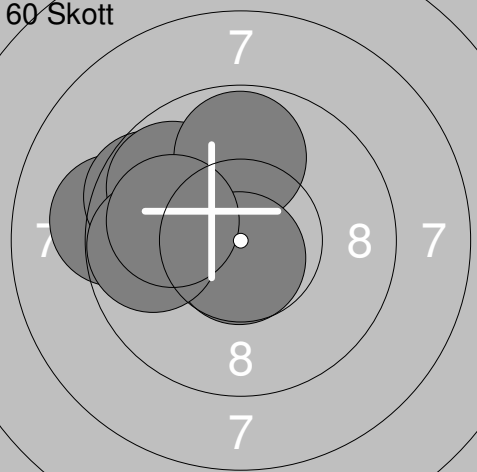
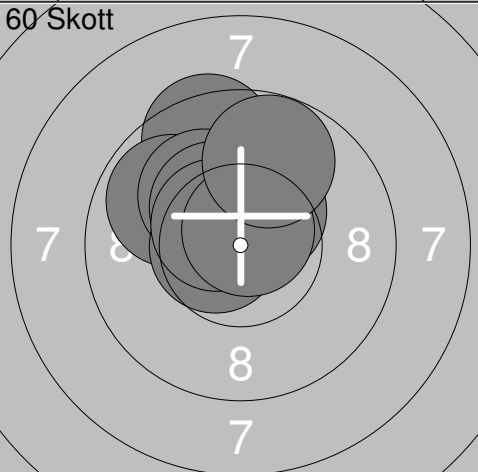
<p>Pröv</p>  <p style="text-align: center;">7 8 7 7</p>	<table border="1" style="width:100%; border-collapse: collapse;"> <tr><td>1:</td><td>8.5</td><td>↗</td></tr> <tr><td>2:</td><td>9.9</td><td>→</td></tr> <tr><td>3:</td><td>10.5x</td><td>↗</td></tr> <tr><td>4:</td><td>10.0</td><td>↓</td></tr> <tr><td>5:</td><td>9.6</td><td>→</td></tr> <tr><td>6:</td><td>10.0</td><td>↓</td></tr> <tr><td>8:</td><td>10.6x</td><td>↓</td></tr> <tr><td>9:</td><td>10.3x</td><td>↗</td></tr> <tr><td>10:</td><td>10.1</td><td>↑</td></tr> <tr><td colspan="2">Serie</td><td>89.5</td></tr> <tr><td colspan="2">Total</td><td>0.0</td></tr> </table>	1:	8.5	↗	2:	9.9	→	3:	10.5x	↗	4:	10.0	↓	5:	9.6	→	6:	10.0	↓	8:	10.6x	↓	9:	10.3x	↗	10:	10.1	↑	Serie		89.5	Total		0.0	<p>Pröv</p>  <p style="text-align: center;">7 8 8 7</p>	<table border="1" style="width:100%; border-collapse: collapse;"> <tr><td>11:</td><td>9.4</td><td>↘</td></tr> <tr><td>13:</td><td>9.8</td><td>↘</td></tr> <tr><td>14:</td><td>10.5x</td><td>↘</td></tr> <tr><td>15:</td><td>10.3x</td><td>↘</td></tr> <tr><td>16:</td><td>10.4x</td><td>↘</td></tr> <tr><td>17:</td><td>10.4x</td><td>↖</td></tr> <tr><td>18:</td><td>10.6x</td><td>←</td></tr> <tr><td>19:</td><td>8.7</td><td>↓</td></tr> <tr><td>20:</td><td>10.4x</td><td>←</td></tr> <tr><td colspan="2">Serie</td><td>90.5</td></tr> <tr><td colspan="2">Total</td><td>0.0</td></tr> </table>	11:	9.4	↘	13:	9.8	↘	14:	10.5x	↘	15:	10.3x	↘	16:	10.4x	↘	17:	10.4x	↖	18:	10.6x	←	19:	8.7	↓	20:	10.4x	←	Serie		90.5	Total		0.0						
1:	8.5	↗																																																																									
2:	9.9	→																																																																									
3:	10.5x	↗																																																																									
4:	10.0	↓																																																																									
5:	9.6	→																																																																									
6:	10.0	↓																																																																									
8:	10.6x	↓																																																																									
9:	10.3x	↗																																																																									
10:	10.1	↑																																																																									
Serie		89.5																																																																									
Total		0.0																																																																									
11:	9.4	↘																																																																									
13:	9.8	↘																																																																									
14:	10.5x	↘																																																																									
15:	10.3x	↘																																																																									
16:	10.4x	↘																																																																									
17:	10.4x	↖																																																																									
18:	10.6x	←																																																																									
19:	8.7	↓																																																																									
20:	10.4x	←																																																																									
Serie		90.5																																																																									
Total		0.0																																																																									
<p>Pröv</p>  <p style="text-align: center;">7 8 8 7</p>	<table border="1" style="width:100%; border-collapse: collapse;"> <tr><td>21:</td><td>10.7x</td><td>←</td></tr> <tr><td>22:</td><td>10.3x</td><td>←</td></tr> <tr><td>23:</td><td>10.7x</td><td>↓</td></tr> <tr><td>24:</td><td>10.5x</td><td>↗</td></tr> <tr><td>25:</td><td>9.9</td><td>↓</td></tr> <tr><td>26:</td><td>9.6</td><td>↓</td></tr> <tr><td>27:</td><td>10.3x</td><td>↓</td></tr> <tr><td colspan="2">Serie</td><td>72.0</td></tr> <tr><td colspan="2">Total</td><td>0.0</td></tr> </table>	21:	10.7x	←	22:	10.3x	←	23:	10.7x	↓	24:	10.5x	↗	25:	9.9	↓	26:	9.6	↓	27:	10.3x	↓	Serie		72.0	Total		0.0	<p>60 Skott</p>  <p style="text-align: center;">7 8 8 7</p>	<table border="1" style="width:100%; border-collapse: collapse;"> <tr><td>1:</td><td>9.5</td><td>↓</td></tr> <tr><td>2:</td><td>10.6x</td><td>←</td></tr> <tr><td>3:</td><td>10.2x</td><td>←</td></tr> <tr><td>4:</td><td>10.3x</td><td>←</td></tr> <tr><td>5:</td><td>9.5</td><td>←</td></tr> <tr><td>6:</td><td>9.2</td><td>←</td></tr> <tr><td>7:</td><td>10.3x</td><td>↖</td></tr> <tr><td>8:</td><td>10.6x</td><td>→</td></tr> <tr><td>9:</td><td>10.1</td><td>↘</td></tr> <tr><td>10:</td><td>9.9</td><td>↑</td></tr> <tr><td colspan="2">Serie</td><td>100.2</td></tr> <tr><td colspan="2">Total</td><td>100.2</td></tr> </table>	1:	9.5	↓	2:	10.6x	←	3:	10.2x	←	4:	10.3x	←	5:	9.5	←	6:	9.2	←	7:	10.3x	↖	8:	10.6x	→	9:	10.1	↘	10:	9.9	↑	Serie		100.2	Total		100.2									
21:	10.7x	←																																																																									
22:	10.3x	←																																																																									
23:	10.7x	↓																																																																									
24:	10.5x	↗																																																																									
25:	9.9	↓																																																																									
26:	9.6	↓																																																																									
27:	10.3x	↓																																																																									
Serie		72.0																																																																									
Total		0.0																																																																									
1:	9.5	↓																																																																									
2:	10.6x	←																																																																									
3:	10.2x	←																																																																									
4:	10.3x	←																																																																									
5:	9.5	←																																																																									
6:	9.2	←																																																																									
7:	10.3x	↖																																																																									
8:	10.6x	→																																																																									
9:	10.1	↘																																																																									
10:	9.9	↑																																																																									
Serie		100.2																																																																									
Total		100.2																																																																									
<p>60 Skott</p>  <p style="text-align: center;">7 8 8 7</p>	<table border="1" style="width:100%; border-collapse: collapse;"> <tr><td>11:</td><td>10.7x</td><td>↖</td></tr> <tr><td>12:</td><td>10.4x</td><td>↓</td></tr> <tr><td>13:</td><td>10.7x</td><td>←</td></tr> <tr><td>14:</td><td>10.5x</td><td>↗</td></tr> <tr><td>15:</td><td>10.3x</td><td>↗</td></tr> <tr><td>16:</td><td>9.9</td><td>←</td></tr> <tr><td>17:</td><td>9.4</td><td>←</td></tr> <tr><td>18:</td><td>10.3x</td><td>←</td></tr> <tr><td>19:</td><td>10.0</td><td>↗</td></tr> <tr><td>20:</td><td>9.1</td><td>↗</td></tr> <tr><td colspan="2">Serie</td><td>101.3</td></tr> <tr><td colspan="2">Total</td><td>201.5</td></tr> </table>	11:	10.7x	↖	12:	10.4x	↓	13:	10.7x	←	14:	10.5x	↗	15:	10.3x	↗	16:	9.9	←	17:	9.4	←	18:	10.3x	←	19:	10.0	↗	20:	9.1	↗	Serie		101.3	Total		201.5	<p>60 Skott</p>  <p style="text-align: center;">7 8 8 7</p>	<table border="1" style="width:100%; border-collapse: collapse;"> <tr><td>21:</td><td>9.2</td><td>←</td></tr> <tr><td>22:</td><td>10.0</td><td>↗</td></tr> <tr><td>23:</td><td>9.6</td><td>↖</td></tr> <tr><td>24:</td><td>10.3x</td><td>↗</td></tr> <tr><td>25:</td><td>10.1</td><td>↗</td></tr> <tr><td>26:</td><td>9.8</td><td>↗</td></tr> <tr><td>27:</td><td>9.8</td><td>↑</td></tr> <tr><td>28:</td><td>10.7x</td><td>↓</td></tr> <tr><td>29:</td><td>9.8</td><td>←</td></tr> <tr><td>30:</td><td>10.0</td><td>←</td></tr> <tr><td colspan="2">Serie</td><td>99.3</td></tr> <tr><td colspan="2">Total</td><td>300.8</td></tr> </table>	21:	9.2	←	22:	10.0	↗	23:	9.6	↖	24:	10.3x	↗	25:	10.1	↗	26:	9.8	↗	27:	9.8	↑	28:	10.7x	↓	29:	9.8	←	30:	10.0	←	Serie		99.3	Total		300.8
11:	10.7x	↖																																																																									
12:	10.4x	↓																																																																									
13:	10.7x	←																																																																									
14:	10.5x	↗																																																																									
15:	10.3x	↗																																																																									
16:	9.9	←																																																																									
17:	9.4	←																																																																									
18:	10.3x	←																																																																									
19:	10.0	↗																																																																									
20:	9.1	↗																																																																									
Serie		101.3																																																																									
Total		201.5																																																																									
21:	9.2	←																																																																									
22:	10.0	↗																																																																									
23:	9.6	↖																																																																									
24:	10.3x	↗																																																																									
25:	10.1	↗																																																																									
26:	9.8	↗																																																																									
27:	9.8	↑																																																																									
28:	10.7x	↓																																																																									
29:	9.8	←																																																																									
30:	10.0	←																																																																									
Serie		99.3																																																																									
Total		300.8																																																																									
<p>60 Skott</p>  <p style="text-align: center;">7 8 8 7</p>	<table border="1" style="width:100%; border-collapse: collapse;"> <tr><td>31:</td><td>10.6x</td><td>↗</td></tr> <tr><td>32:</td><td>9.5</td><td>↗</td></tr> <tr><td>33:</td><td>9.9</td><td>↗</td></tr> <tr><td>34:</td><td>10.1</td><td>↗</td></tr> <tr><td>35:</td><td>10.4x</td><td>↗</td></tr> <tr><td>36:</td><td>10.6x</td><td>←</td></tr> <tr><td>37:</td><td>10.3x</td><td>↗</td></tr> <tr><td>38:</td><td>10.5x</td><td>↗</td></tr> <tr><td>39:</td><td>10.7x</td><td>↗</td></tr> <tr><td>40:</td><td>9.8</td><td>↑</td></tr> <tr><td colspan="2">Serie</td><td>102.4</td></tr> <tr><td colspan="2">Total</td><td>403.2</td></tr> </table>	31:	10.6x	↗	32:	9.5	↗	33:	9.9	↗	34:	10.1	↗	35:	10.4x	↗	36:	10.6x	←	37:	10.3x	↗	38:	10.5x	↗	39:	10.7x	↗	40:	9.8	↑	Serie		102.4	Total		403.2																																						
31:	10.6x	↗																																																																									
32:	9.5	↗																																																																									
33:	9.9	↗																																																																									
34:	10.1	↗																																																																									
35:	10.4x	↗																																																																									
36:	10.6x	←																																																																									
37:	10.3x	↗																																																																									
38:	10.5x	↗																																																																									
39:	10.7x	↗																																																																									
40:	9.8	↑																																																																									
Serie		102.4																																																																									
Total		403.2																																																																									

Skjutlag 1	Tavla 37	Joachim Lundgren	
S		Umeå Skf	
08.04.2017		UMEKULAN 2017	Umeå skytteallians
Pröv 	1: 9.9 ↓ 2: 10.8x ↓ 3: 10.2x ↓ 4: 10.7x ↓ 5: 9.9 ← 6: 9.8 → 7: 9.8 ↓ 8: 10.4x ← 9: 9.9 → 10: 10.1 ← Serie 101.5 Total 0.0	Pröv 	11: 9.7 ↗ 12: 9.6 → 13: 10.9x ↓ 14: 9.5 ↓ 15: 10.7x ↓ 16: 10.8x ↗ 17: 10.6x ← 18: 10.7x ← 19: 9.4 ↓ 20: 9.3 ↓ Serie 101.2 Total 0.0
Pröv 	21: 10.6x ← 22: 10.1 ← 23: 9.8 ↓ 24: 9.8 ↗ 25: 10.5x ↓ 26: 10.7x ↗ Serie 61.5 Total 0.0	60 Skott 	1: 9.9 ↑ 2: 9.7 ← 3: 10.6x → 4: 10.3x ↓ 5: 10.3x ↓ 6: 10.3x ↗ 7: 10.4x ← 8: 10.4x ↗ 9: 10.1 ↑ 10: 9.7 ↓ Serie 101.7 Total 101.7
60 Skott 	11: 10.4x ↗ 12: 10.5x ↗ 13: 10.4x ↓ 14: 10.3x ↗ 15: 10.5x ↓ 16: 10.3x ↗ 17: 10.0 ↗ 18: 10.2x → 19: 10.7x ↗ 20: 10.5x ↗ Serie 103.8 Total 205.5	60 Skott 	21: 10.5x ↗ 22: 10.4x ↗ 23: 10.0 ← 24: 10.5x ← 25: 10.2x ↗ 26: 9.6 ← 27: 10.5x ↗ 28: 10.8x ↑ 29: 10.8x ↗ 30: 10.3x ↗ Serie 103.6 Total 309.1
60 Skott 	31: 9.3 ← 32: 10.6x ↓ 33: 10.3x ↓ 34: 10.4x ↗ 35: 10.5x → 36: 10.7x ← 37: 10.3x ↓ 38: 10.2x ↑ 39: 9.7 ↗ 40: 10.2x ↓ Serie 102.2 Total 411.3		

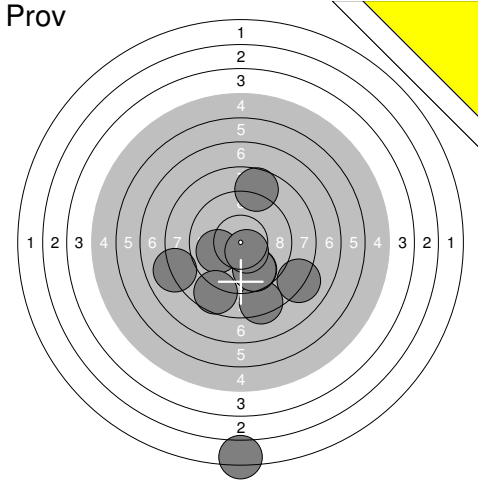
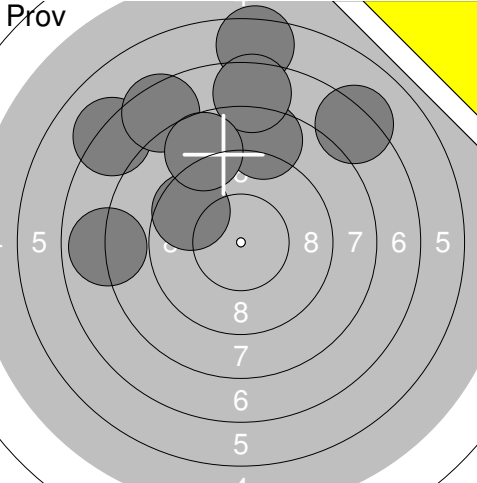
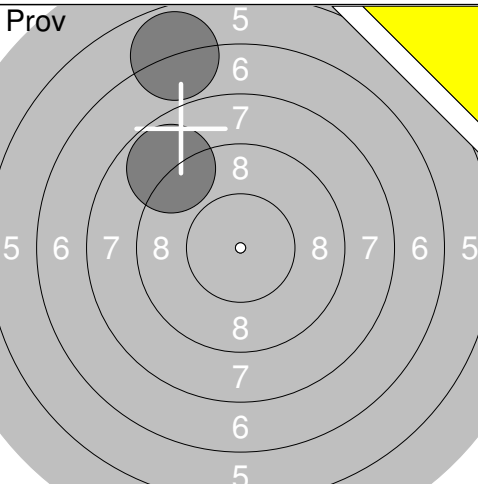
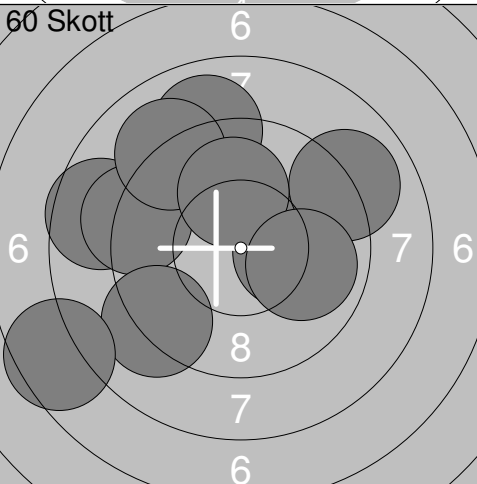
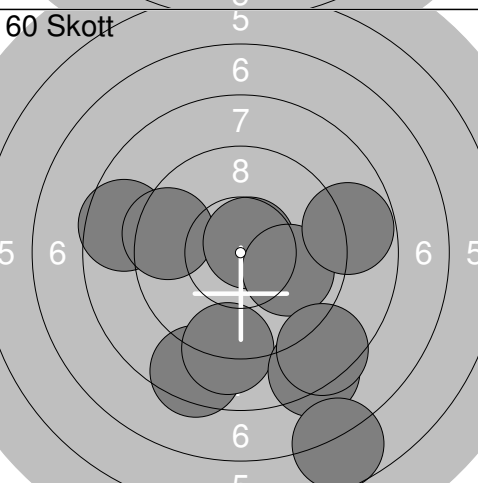
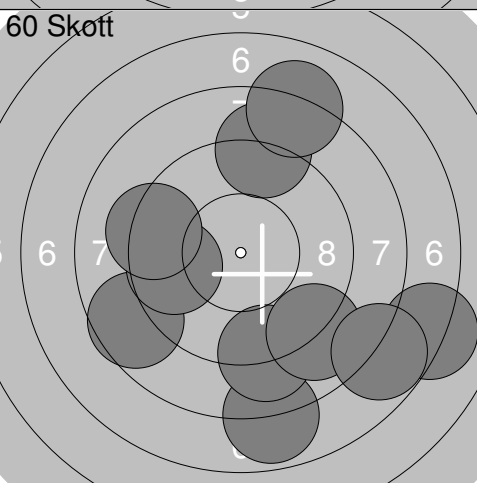
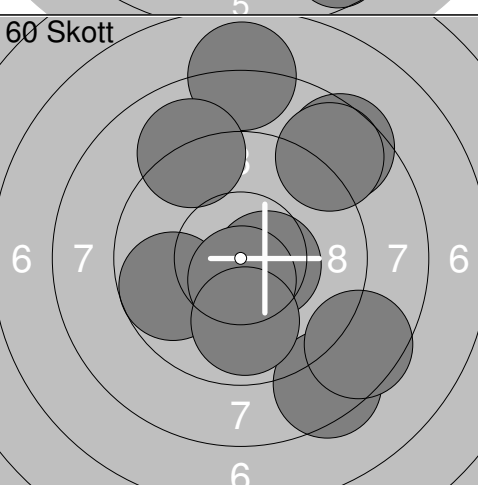
Skjuttlag 1	Tavla 38	Ulf Sjöström	
S		Ramselefors Skf	
08.04.2017		UMEKULAN 2017	Umeå skytteallians
Prov 	1: 8.1 ↘ 2: 2.2 ↓ 3: 8.4 ↓ 4: 9.9 ← 5: 8.0 ← 6: 9.7 ↓ 7: 9.7 ↓ 8: 10.5x ↓ 9: 8.7 ↑ 10: 8.7 ↓ Serie 83.9 Total 0.0	Prov 	11: 7.2 ↖ 12: 8.6 ↑ 13: 7.2 ↗ 14: 9.6 ↖ 16: 6.4 ↑ 17: 7.5 ↗ 18: 7.6 ↑ 19: 7.9 ← 20: 8.7 ↑ Serie 70.7 Total 0.0
Prov 	21: 8.8 ↗ 22: 6.9 ↗ Serie 15.7 Total 0.0	60 Skott 	1: 10.2x → 2: 9.0 ↗ 3: 8.6 ← 4: 9.2 ← 5: 9.0 ↑ 6: 9.1 ↗ 7: 10.0 ↑ 8: 9.1 ↓ 9: 9.9 → 10: 7.6 ← Serie 91.7 Total 91.7
60 Skott 	11: 8.6 ← 12: 8.5 ↓ 13: 9.0 ↓ 14: 9.5 ← 15: 10.7x ↗ 16: 10.0 → 17: 8.2 ↓ 18: 8.8 → 19: 6.7 ↓ 20: 8.5 ↓ Serie 88.5 Total 180.2	60 Skott 	21: 8.6 ↖ 22: 9.0 ↑ 23: 9.7 ← 24: 7.9 ↓ 25: 9.3 ← 26: 9.0 ↓ 27: 8.9 ↓ 28: 8.1 ↑ 29: 7.1 → 30: 7.8 ↓ Serie 85.4 Total 265.6
60 Skott 	31: 7.9 ↑ 32: 9.0 ↗ 33: 9.7 ← 34: 8.4 ↓ 35: 10.5x → 36: 8.5 ↓ 37: 8.5 ↗ 38: 10.6x ↓ 39: 8.7 ↗ 40: 9.9 ↓ Serie 91.7 Total 357.3		

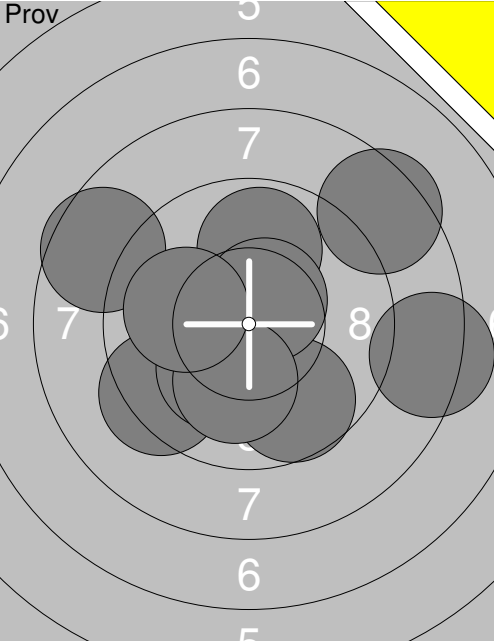
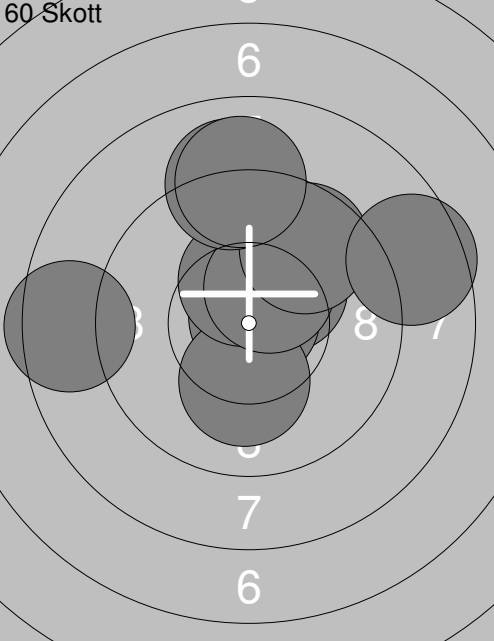
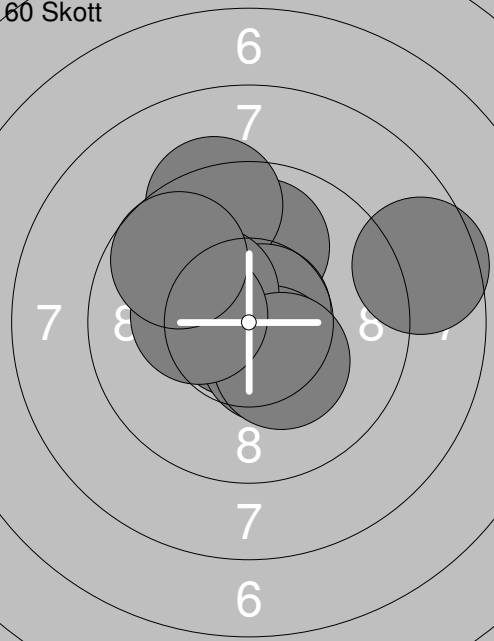
Skjuttlag	Tavla	Nicolle Nygren	
S	Umeå Skf		
08.04.2017	UMEKULAN 2017	Umeå skytteallians	
Prov		1: 8.5 ↗ 2: 8.3 → 3: 9.3 ↙ 4: 9.9 ↑ 5: 8.6 ↖ 6: 9.7 ↓ 7: 10.2x↘ 8: 10.5x↗ 9: 10.1 ↓ 10: 10.0 ←	11: 9.7 → 12: 8.6 ↖ 13: 10.5x↗ 14: 10.4x↗ 15: 10.7x↘ 16: 10.5x↘
		Serie 95.1	Serie 60.4
		Total 0.0	Total 0.0
60 Skott		1: 10.3x↗ 2: 10.8x↗ 3: 10.2x↓ 4: 10.4x↗ 5: 10.4x↗ 6: 9.7 ↗ 7: 9.0 ↑ 8: 8.5 ← 9: 8.6 → 10: 9.0 ↑	11: 9.8 ↗ 12: 9.2 ↖ 13: 10.4x→ 14: 10.6x↘ 15: 9.3 ↓ 16: 10.4x↘ 17: 9.3 ↖ 18: 9.9 ↖ 19: 10.4x↖ 20: 9.2 ↖
		Serie 96.9	Serie 98.5
		Total 96.9	Total 195.4
60 Skott		21: 8.6 → 22: 10.8x↖ 23: 10.0 ↑ 24: 9.4 ↑ 25: 10.7x↗ 26: 10.5x↘ 27: 10.3x↖ 28: 10.3x↘ 29: 10.3x↖ 30: 9.7 ↖	31: 9.5 → 32: 10.1 ← 33: 10.8x↖ 34: 10.4x↖ 35: 10.2x↘ 36: 10.8x↘ 37: 9.3 → 38: 10.3x↖ 39: 9.0 ↓ 40: 9.6 ↓
		Serie 100.6	Serie 100.0
		Total 296.0	Total 396.0

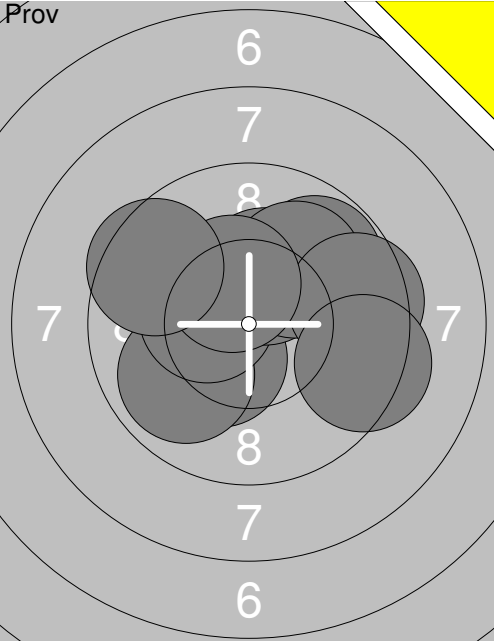
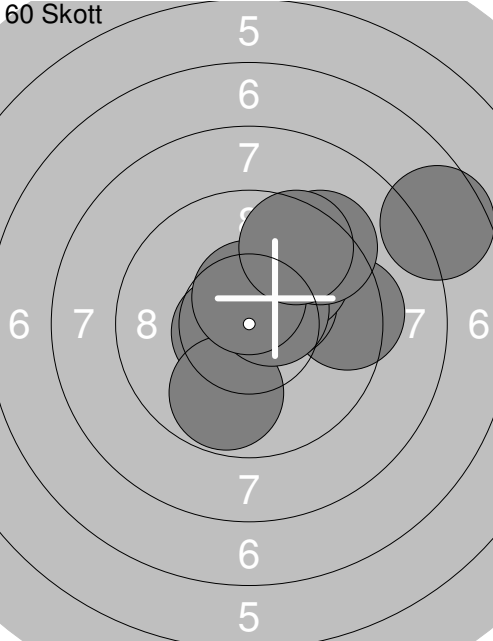
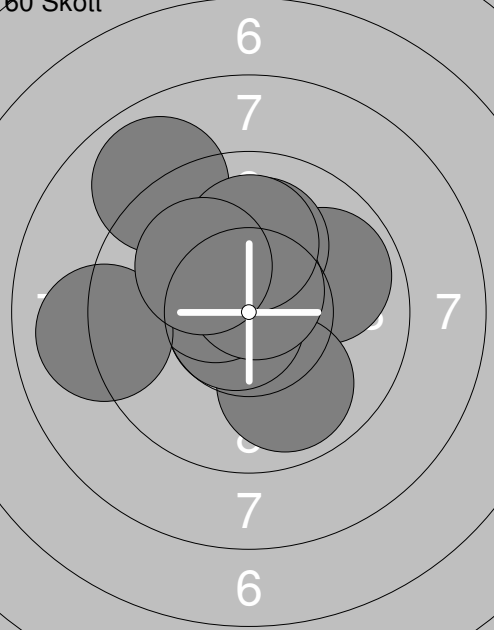
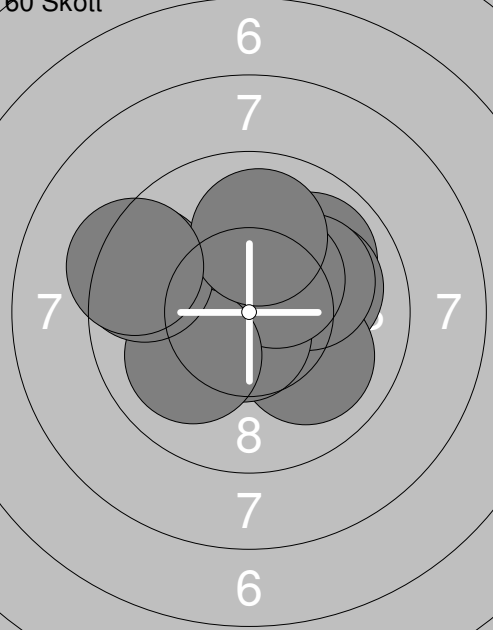
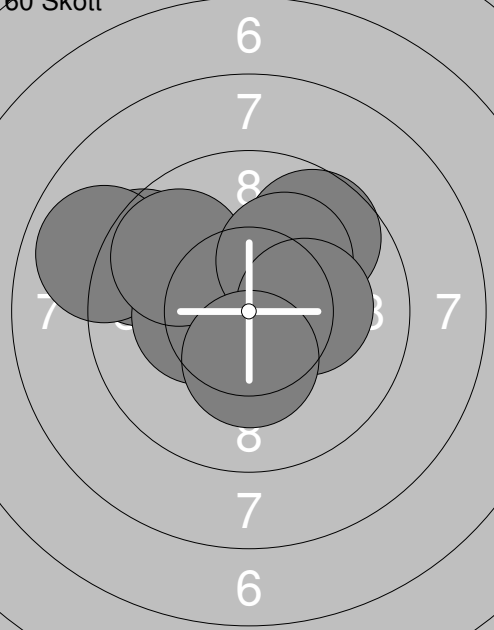
Skjuttag	Tavla	Erika Bergqvist	
2	4		
S	Umeå Skf		
08.04.2017	UMEKULAN 2017	Umeå skytteallians	
Prov 	60 Skott 	1: 10.4x ↘ 2: 9.9 ↙ 3: 10.4x ↘ 4: 10.3x ↗ 5: 9.8 ↗ 6: 10.0 ↗ 7: 9.5 → 8: 10.4x ↗ 9: 9.4 → 10: 9.5 ↙ Serie 99.6 Total 0.0	1: 9.4 → 2: 10.6x ↘ 3: 9.8 ↓ 4: 10.4x ↗ 5: 9.9 ↗ 6: 10.5x ↗ 7: 9.3 ↗ 8: 10.5x ↗ 9: 7.6 ↗ 10: 9.5 ↗ Serie 97.5 Total 97.5
60 Skott 	60 Skott 	11: 9.9 ↗ 12: 9.9 ↓ 13: 10.1 ↑ 14: 10.7x ↘ 15: 10.5x ↘ 16: 9.0 ← 17: 10.7x ↗ 18: 8.9 ↗ 19: 10.1 ↑ 20: 10.1 ↙ Serie 99.9 Total 197.4	21: 9.9 ↗ 22: 10.0 → 23: 10.0 ↘ 24: 10.1 ↗ 25: 10.7x ↓ 26: 10.4x ↗ 27: 10.0 ↙ 28: 9.5 ← 29: 10.0 ↑ 30: 9.3 ↙ Serie 99.9 Total 297.3
60 Skott 	31: 9.4 ↙ 32: 10.4x ↘ 33: 9.7 ↗ 34: 8.9 ↙ 35: 10.3x ↘ 36: 10.7x ↘ 37: 9.8 ↙ 38: 10.1 ↗ 39: 10.2x → 40: 10.3x ↓ Serie 99.8 Total 397.1		

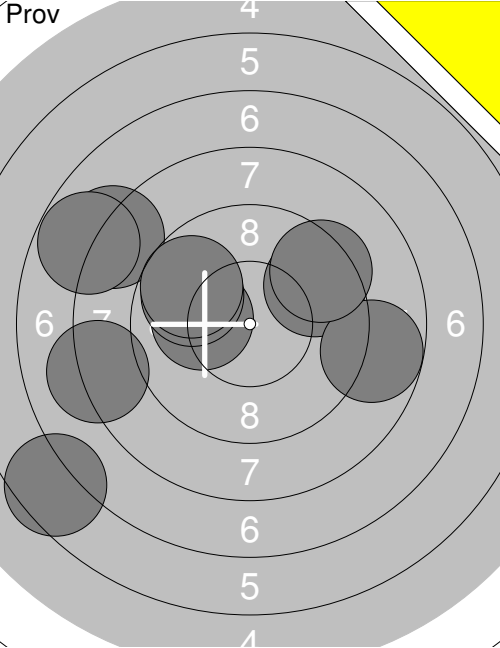
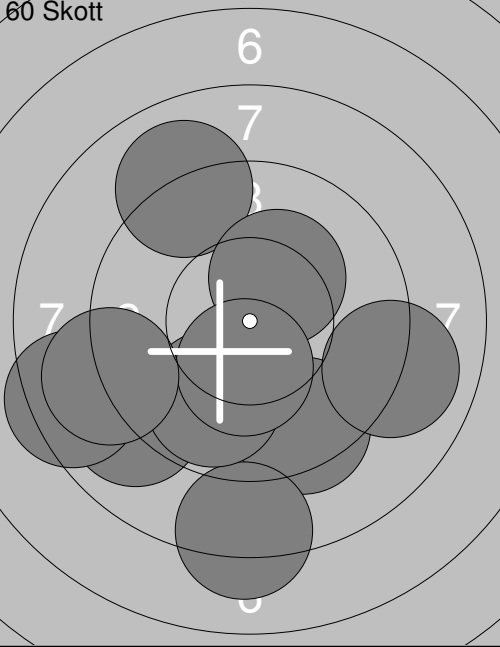
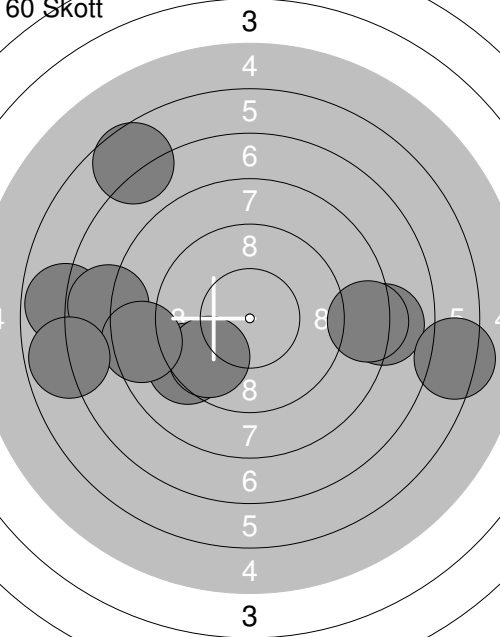
Skjutlag	Tavla	Hanna Johansson	
S	Vännäs Skf		
08.04.2017	UMEKULAN 2017	Umeå skytteallians	
Prov		1: 10.1 ← 2: 6.5 ↙ 3: 8.2 ← 4: 9.6 ↗ 5: 8.1 ↖ 6: 8.8 → 7: 9.8 ← 8: 7.8 ↖ 9: 9.4 ↗ 10: 9.7 ↖	Prov
		Serie 88.0	11: 8.6 ↑ 12: 8.2 ← 13: 9.3 ↓
		Total 0.0	Serie 26.1
			Total 0.0
60 Skott		1: 9.4 ↓ 2: 9.0 ↗ 3: 8.2 ↓ 4: 9.0 ← 5: 8.4 ← 6: 10.3x ↗ 7: 9.8 ↓ 8: 9.0 → 9: 10.3x ↓ 10: 9.0 ←	60 Skott
		Serie 92.4	11: 9.6 ← 12: 9.2 ← 13: 9.6 ↓ 14: 6.5 ← 15: 9.5 → 16: 8.8 ↗ 17: 9.5 ← 18: 8.6 ← 19: 10.0 ↓ 20: 9.5 ←
		Total 92.4	Serie 90.8
			Total 183.2
60 Skott		21: 6.9 ← 22: 8.0 → 23: 6.3 → 24: 9.2 ← 25: 7.8 ← 26: 9.7 ↙ 27: 8.5 ← 28: 6.6 ↗ 29: 8.3 → 30: 6.8 ←	60 Skott
		Serie 78.1	31: 10.2x ← 32: 9.8 ↓ 33: 8.0 ↓ 34: 10.4x ← 35: 9.1 ← 36: 10.2x ← 37: 9.9 ↓ 38: 8.7 → 39: 7.9 ↓ 40: 7.8 ↓
		Total 261.3	Serie 92.0
			Total 353.3

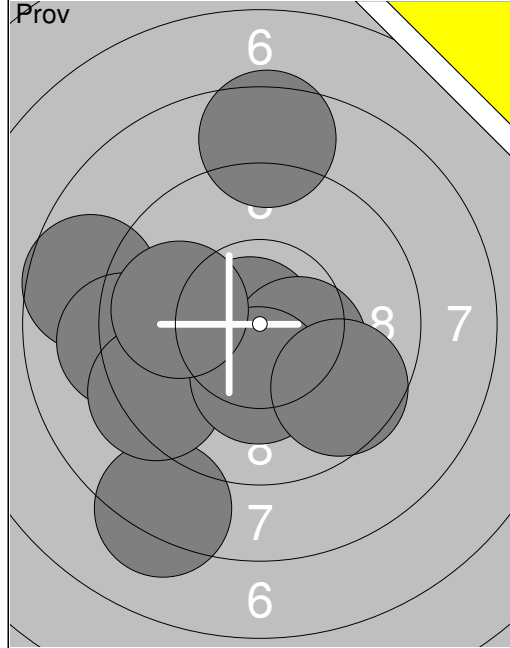

1:	8.2	↘
2:	8.7	←
3:	10.8	↔
4:	9.2	←
5:	10.4	↘
6:	9.3	↙
7:	10.3	↘
8:	9.6	↘
9:	8.5	↑
10:	9.9	←
Serie		94.9
Total		0.0

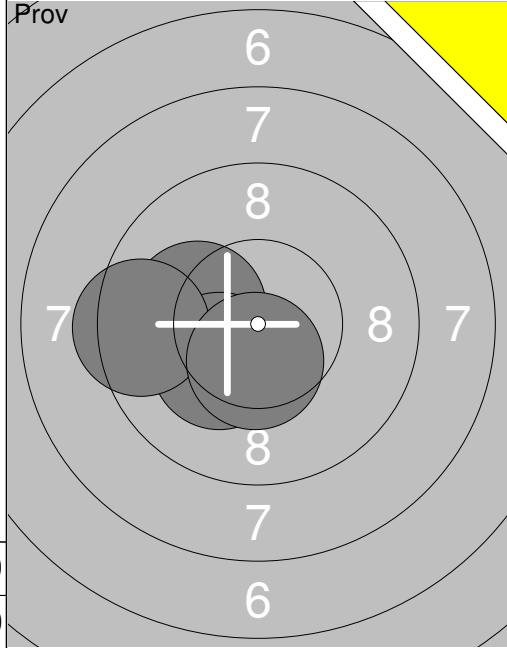

11:	10.1	←
12:	10.2	↘
13:	9.4	←
14:	10.5	↘
Serie		40.2
Total		0.0

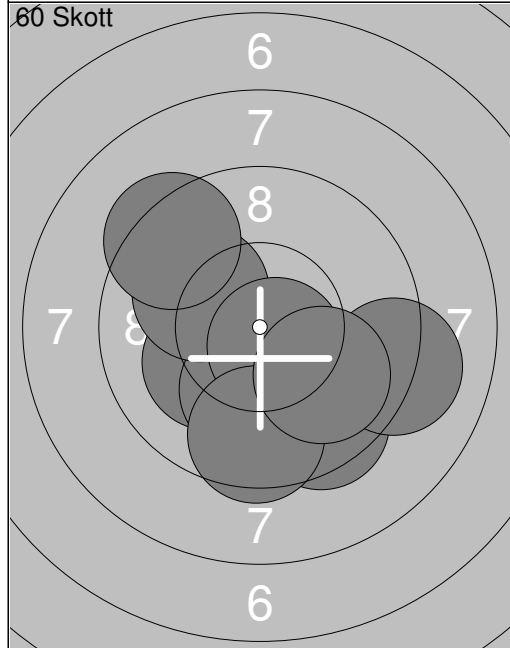

1:	10.3	↘
2:	10.2	↘
3:	10.1	↘
4:	9.5	↘
5:	9.1	→
6:	10.1	↙
7:	10.6	↘
8:	9.5	↘
9:	9.3	↖
10:	9.9	↘
Serie		98.6
Total		98.6

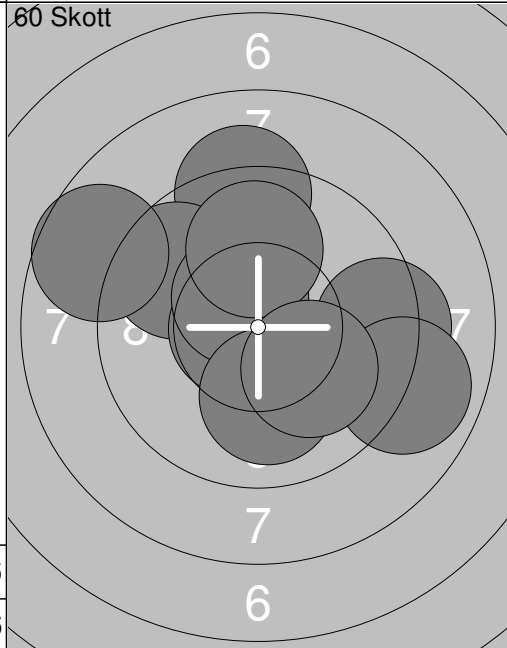

11:	9.2	↑
12:	9.7	↖
13:	9.3	→
14:	10.7	↔
15:	8.7	↙
16:	10.5	↘
17:	10.0	↘
18:	9.9	↑
19:	8.9	→
20:	10.1	↘
Serie		97.0
Total		195.6

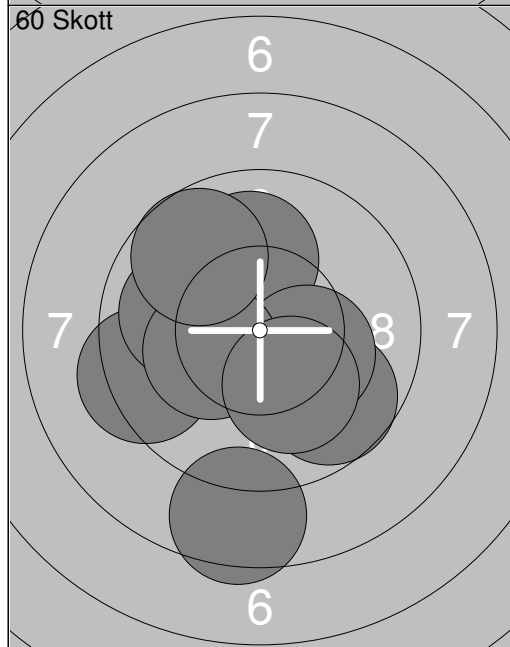

21:	10.0	←
22:	9.7	↘
23:	10.0	↑
24:	9.4	←
25:	8.5	↘
26:	10.3	↘
27:	10.0	←
28:	10.3	↔
29:	9.7	↖
30:	10.1	↘
Serie		98.0
Total		293.6

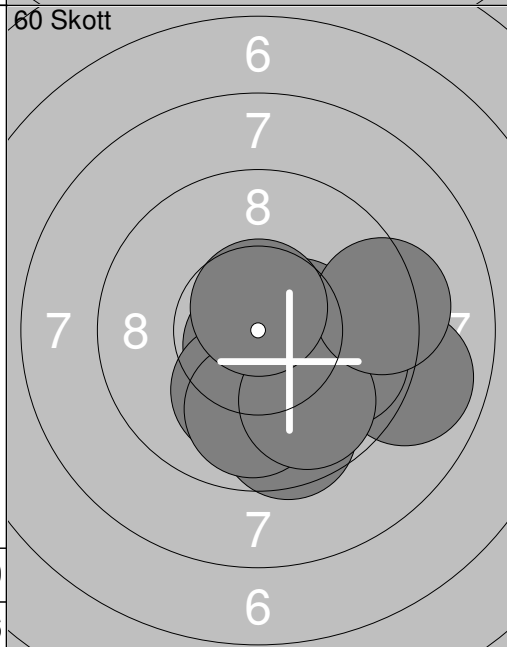

31:	8.9	→
32:	10.5	↘
33:	10.7	↘
34:	9.8	→
35:	9.6	↘
36:	10.1	↘
37:	9.9	↘
38:	9.8	↘
39:	9.3	→
40:	10.6	↑
Serie		99.2
Total		392.8

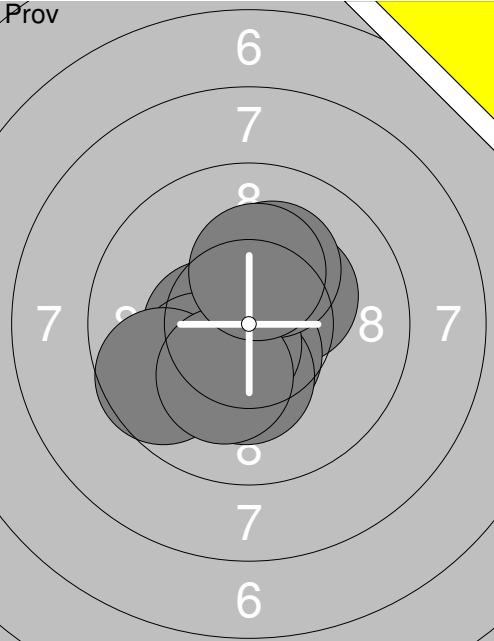
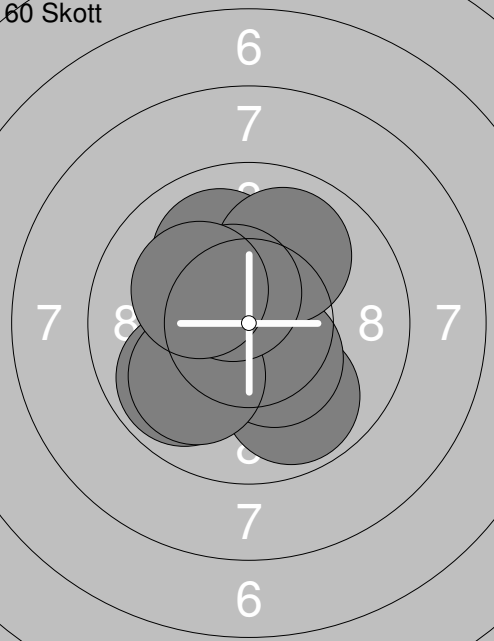
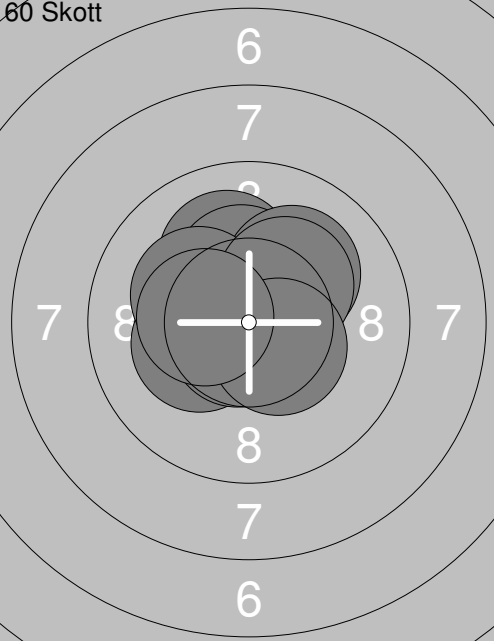
Skjutlag	Tavla	Anna Mårtensson	
2	8		
S	Kyrkås Skf		
08.04.2017	UMEKULAN 2017	Umeå skytteallians	
Prov		1: 10.3x↗ 2: 10.6x↓ 3: 10.3x↓ 4: 10.6x↘ 5: 10.4x← 6: 10.2x↘ 7: 10.2x↗ 8: 9.6 ← 9: 10.2x↓ 10: 10.3x↗ Serie 102.7 Total 0.0	11: 10.3x↘ 12: 10.3x↗ 13: 10.1↙ 14: 10.6x↗ 15: 10.3x→ Serie 51.6 Total 0.0
60 Skott		1: 10.0 ↗ 2: 9.9 ↙ 3: 10.4x↓ 4: 10.3x↘ 5: 9.9 ↘ 6: 10.4x↓ 7: 10.0 ↗ 8: 10.0 ↙ 9: 10.5x↘ 10: 10.2x↘ Serie 101.6 Total 101.6	11: 10.6x↗ 12: 10.5x↗ 13: 10.2x↘ 14: 10.0 ↗ 15: 9.6 ↙ 16: 10.6x→ 17: 10.6x→ 18: 10.8x↓ 19: 10.6x↓ 20: 10.7x↗ Serie 104.2 Total 205.8
60 Skott		21: 10.3x↘ 22: 10.1 ↗ 23: 10.6x↗ 24: 10.3x↗ 25: 10.7x↘ 26: 10.1 ↗ 27: 10.2x↘ 28: 10.3x↗ 29: 10.5x↘ 30: 10.4x← Serie 103.5 Total 309.3	31: 10.3x↗ 32: 10.6x↓ 33: 10.3x↗ 34: 10.3x↘ 35: 9.7 ↗ 36: 10.6x↘ 37: 10.2x↗ 38: 10.5x↘ 39: 10.4x↘ 40: 10.5x↘ Serie 103.4 Total 412.7

	<p>60 Skott</p> <table style="width:100%;"> <tr><td>1:</td><td>9.0</td><td>↓</td></tr> <tr><td>2:</td><td>8.8</td><td>↓</td></tr> <tr><td>3:</td><td>9.7</td><td>←</td></tr> <tr><td>4:</td><td>8.3</td><td>←</td></tr> <tr><td>5:</td><td>9.8</td><td>↓</td></tr> <tr><td>6:</td><td>10.7</td><td>↖</td></tr> <tr><td>7:</td><td>8.8</td><td>←</td></tr> <tr><td>8:</td><td>9.3</td><td>↓</td></tr> <tr><td>9:</td><td>9.6</td><td>↑</td></tr> <tr><td>10:</td><td>10.3</td><td>↗</td></tr> </table> <table style="width:100%; border-top: 1px solid black;"> <tr><td>Serie</td><td style="text-align: right;">94.3</td></tr> <tr><td>Total</td><td style="text-align: right;">0.0</td></tr> </table>	1:	9.0	↓	2:	8.8	↓	3:	9.7	←	4:	8.3	←	5:	9.8	↓	6:	10.7	↖	7:	8.8	←	8:	9.3	↓	9:	9.6	↑	10:	10.3	↗	Serie	94.3	Total	0.0	 <table style="width:100%;"> <tr><td>1:</td><td>10.3</td><td>↗</td></tr> <tr><td>2:</td><td>10.5</td><td>↗</td></tr> <tr><td>3:</td><td>9.9</td><td>↖</td></tr> <tr><td>4:</td><td>9.3</td><td>↓</td></tr> <tr><td>5:</td><td>9.0</td><td>→</td></tr> <tr><td>6:</td><td>9.2</td><td>↗</td></tr> <tr><td>7:</td><td>9.1</td><td>↓</td></tr> <tr><td>8:</td><td>9.1</td><td>↙</td></tr> <tr><td>9:</td><td>10.6</td><td>↘</td></tr> <tr><td>10:</td><td>8.3</td><td>→</td></tr> </table> <table style="width:100%; border-top: 1px solid black;"> <tr><td>Serie</td><td style="text-align: right;">95.3</td></tr> <tr><td>Total</td><td style="text-align: right;">95.3</td></tr> </table>	1:	10.3	↗	2:	10.5	↗	3:	9.9	↖	4:	9.3	↓	5:	9.0	→	6:	9.2	↗	7:	9.1	↓	8:	9.1	↙	9:	10.6	↘	10:	8.3	→	Serie	95.3	Total	95.3
1:	9.0	↓																																																																				
2:	8.8	↓																																																																				
3:	9.7	←																																																																				
4:	8.3	←																																																																				
5:	9.8	↓																																																																				
6:	10.7	↖																																																																				
7:	8.8	←																																																																				
8:	9.3	↓																																																																				
9:	9.6	↑																																																																				
10:	10.3	↗																																																																				
Serie	94.3																																																																					
Total	0.0																																																																					
1:	10.3	↗																																																																				
2:	10.5	↗																																																																				
3:	9.9	↖																																																																				
4:	9.3	↓																																																																				
5:	9.0	→																																																																				
6:	9.2	↗																																																																				
7:	9.1	↓																																																																				
8:	9.1	↙																																																																				
9:	10.6	↘																																																																				
10:	8.3	→																																																																				
Serie	95.3																																																																					
Total	95.3																																																																					

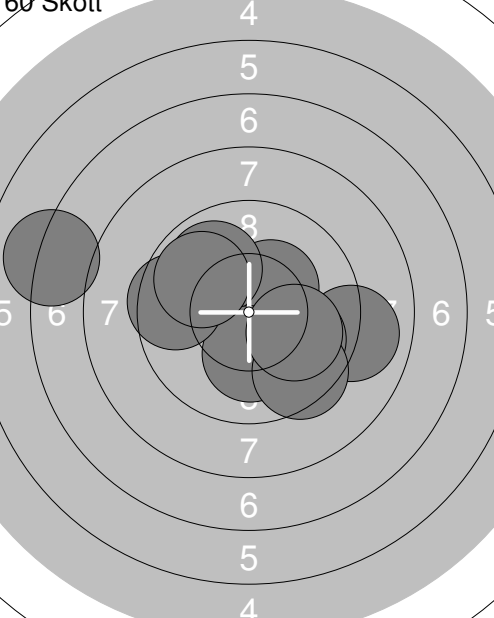
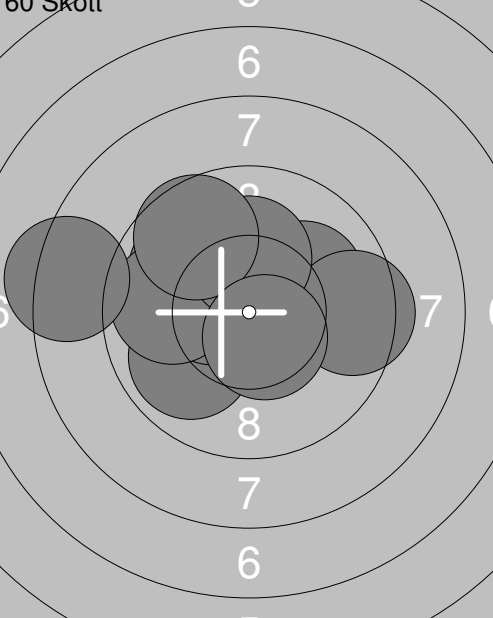
	<p>60 Skott</p> <table style="width:100%;"> <tr><td>11:</td><td>10.3</td><td>↗</td></tr> <tr><td>12:</td><td>9.0</td><td>→</td></tr> <tr><td>13:</td><td>9.9</td><td>↗</td></tr> <tr><td>14:</td><td>10.2</td><td>↓</td></tr> <tr><td>15:</td><td>9.9</td><td>↓</td></tr> <tr><td>16:</td><td>9.6</td><td>←</td></tr> <tr><td>17:</td><td>9.5</td><td>↓</td></tr> <tr><td>18:</td><td>10.0</td><td>→</td></tr> <tr><td>19:</td><td>9.9</td><td>↖</td></tr> <tr><td>20:</td><td>7.1</td><td>←</td></tr> </table> <table style="width:100%; border-top: 1px solid black;"> <tr><td>Serie</td><td style="text-align: right;">95.4</td></tr> <tr><td>Total</td><td style="text-align: right;">190.7</td></tr> </table>	11:	10.3	↗	12:	9.0	→	13:	9.9	↗	14:	10.2	↓	15:	9.9	↓	16:	9.6	←	17:	9.5	↓	18:	10.0	→	19:	9.9	↖	20:	7.1	←	Serie	95.4	Total	190.7	<p>60 Skott</p>  <table style="width:100%;"> <tr><td>21:</td><td>9.9</td><td>↖</td></tr> <tr><td>22:</td><td>10.4</td><td>↖</td></tr> <tr><td>23:</td><td>10.1</td><td>↗</td></tr> <tr><td>24:</td><td>9.9</td><td>↖</td></tr> <tr><td>25:</td><td>9.5</td><td>→</td></tr> <tr><td>26:</td><td>9.8</td><td>←</td></tr> <tr><td>27:</td><td>10.2</td><td>↑</td></tr> <tr><td>28:</td><td>8.3</td><td>←</td></tr> <tr><td>29:</td><td>9.6</td><td>↖</td></tr> <tr><td>30:</td><td>10.5</td><td>↘</td></tr> </table> <table style="width:100%; border-top: 1px solid black;"> <tr><td>Serie</td><td style="text-align: right;">98.2</td></tr> <tr><td>Total</td><td style="text-align: right;">288.9</td></tr> </table>	21:	9.9	↖	22:	10.4	↖	23:	10.1	↗	24:	9.9	↖	25:	9.5	→	26:	9.8	←	27:	10.2	↑	28:	8.3	←	29:	9.6	↖	30:	10.5	↘	Serie	98.2	Total	288.9
11:	10.3	↗																																																																				
12:	9.0	→																																																																				
13:	9.9	↗																																																																				
14:	10.2	↓																																																																				
15:	9.9	↓																																																																				
16:	9.6	←																																																																				
17:	9.5	↓																																																																				
18:	10.0	→																																																																				
19:	9.9	↖																																																																				
20:	7.1	←																																																																				
Serie	95.4																																																																					
Total	190.7																																																																					
21:	9.9	↖																																																																				
22:	10.4	↖																																																																				
23:	10.1	↗																																																																				
24:	9.9	↖																																																																				
25:	9.5	→																																																																				
26:	9.8	←																																																																				
27:	10.2	↑																																																																				
28:	8.3	←																																																																				
29:	9.6	↖																																																																				
30:	10.5	↘																																																																				
Serie	98.2																																																																					
Total	288.9																																																																					

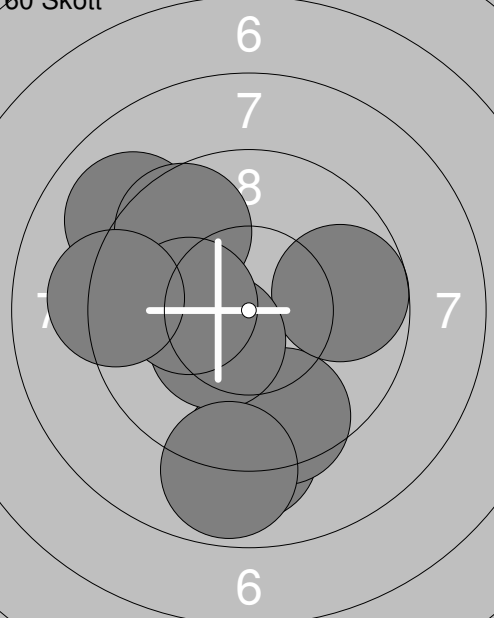
	<p>60 Skott</p> <table style="width:100%;"> <tr><td>31:</td><td>9.1</td><td>↓</td></tr> <tr><td>32:</td><td>9.5</td><td>↓</td></tr> <tr><td>33:</td><td>9.7</td><td>→</td></tr> <tr><td>34:</td><td>9.0</td><td>↖</td></tr> <tr><td>35:</td><td>10.4</td><td>↘</td></tr> <tr><td>36:</td><td>9.6</td><td>↖</td></tr> <tr><td>37:</td><td>10.2</td><td>↖</td></tr> <tr><td>38:</td><td>9.2</td><td>←</td></tr> <tr><td>39:</td><td>8.9</td><td>↓</td></tr> <tr><td>40:</td><td>0.0</td><td></td></tr> </table> <table style="width:100%; border-top: 1px solid black;"> <tr><td>Serie</td><td style="text-align: right;">85.6</td></tr> <tr><td>Total</td><td style="text-align: right;">374.5</td></tr> </table>	31:	9.1	↓	32:	9.5	↓	33:	9.7	→	34:	9.0	↖	35:	10.4	↘	36:	9.6	↖	37:	10.2	↖	38:	9.2	←	39:	8.9	↓	40:	0.0		Serie	85.6	Total	374.5	
31:	9.1	↓																																		
32:	9.5	↓																																		
33:	9.7	→																																		
34:	9.0	↖																																		
35:	10.4	↘																																		
36:	9.6	↖																																		
37:	10.2	↖																																		
38:	9.2	←																																		
39:	8.9	↓																																		
40:	0.0																																			
Serie	85.6																																			
Total	374.5																																			

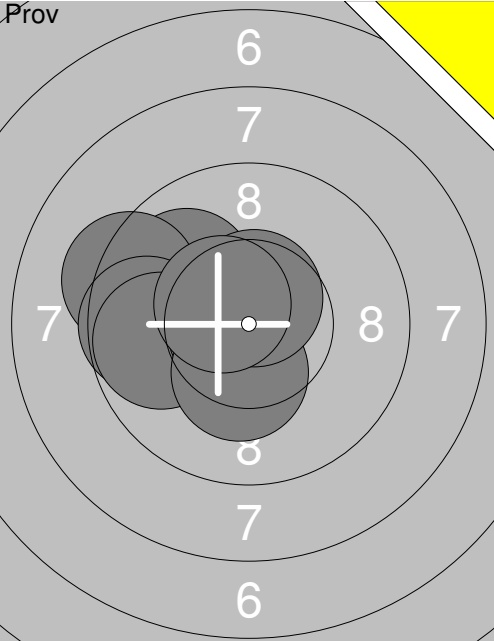
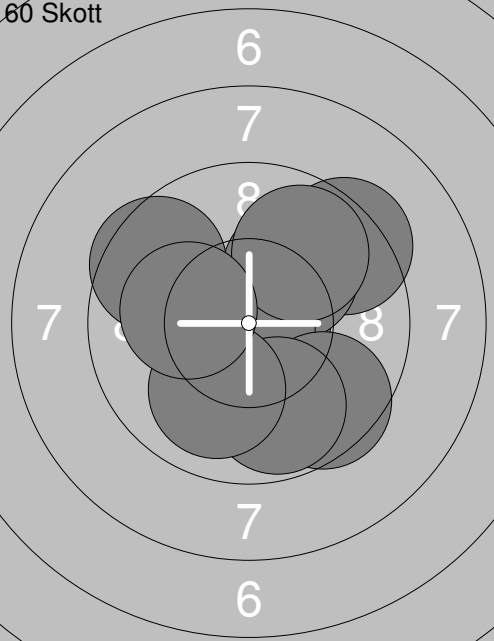
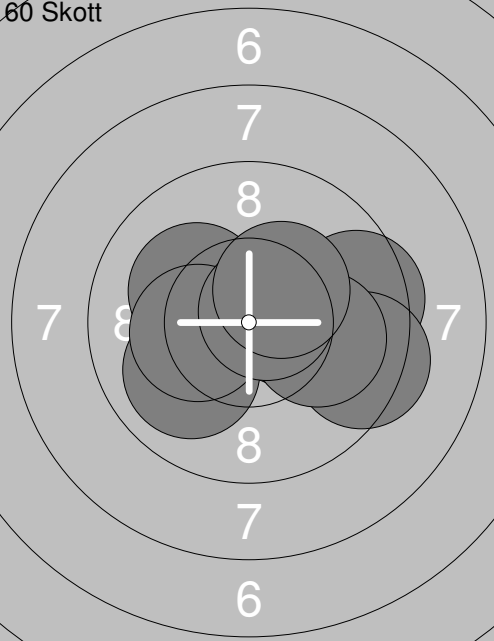
Skjuttag	Tavla	Hanna Lundin	
S	Umeå Skf		
08.04.2017	UMEKULAN 2017	Umeå skytteallians	
Prov		1: 10.8x ↘ 2: 9.9 ↖ 3: 9.3 ↖ 4: 9.6 ← 5: 9.8 ← 6: 10.8x ↘ 7: 10.8x ↘ 8: 10.3x ↓ 9: 10.6x ↑ 10: 10.5x ↘ Serie 102.4 Total 0.0	11: 10.7x ↘ 12: 9.7 ↗ Serie 20.4 Total 0.0
60 Skott		1: 9.3 ↗ 2: 10.8x → 3: 10.1 ↗ 4: 10.9x ↓ 5: 9.8 ↗ 6: 9.6 ↓ 7: 9.8 ↓ 8: 9.5 ↖ 9: 10.0 ↓ 10: 10.1 ← Serie 99.9 Total 99.9	11: 9.8 ↖ 12: 10.1 ↓ 13: 10.2x ↓ 14: 9.7 ← 15: 10.4x ← 16: 10.7x ↓ 17: 9.2 ↗ 18: 9.9 ← 19: 10.1 ← 20: 10.2x ↗ Serie 100.3 Total 200.2
60 Skott		21: 10.0 ↙ 22: 10.2x ↘ 23: 10.1 → 24: 10.3x ← 25: 9.5 → 26: 9.4 → 27: 10.4x → 28: 10.0 → 29: 10.7x ↗ 30: 10.4x ↗ Serie 101.0 Total 301.2	31: 10.5x ↓ 32: 10.6x ↘ 33: 10.3x ↘ 34: 10.5x ↗ 35: 10.3x ↑ 36: 9.3 → 37: 10.5x ↗ 38: 10.6x ↓ 39: 10.4x ↘ 40: 10.1 ↑ Serie 103.1 Total 404.3

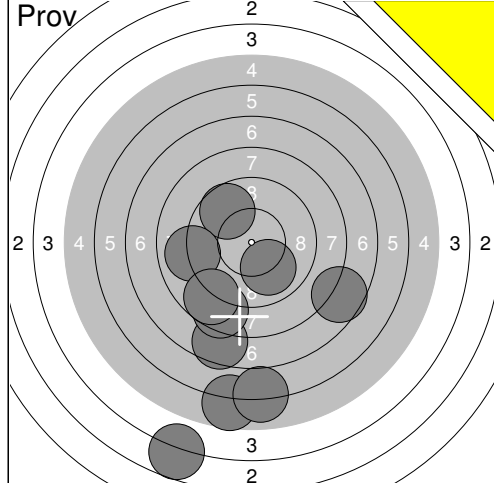

1:	10.0	↘
2:	7.6	↘
3:	7.6	↘
4:	8.5	↘
5:	5.7	↘
6:	9.7	↗
7:	6.0	↘
8:	9.0	←
9:	3.7	↘
10:	8.8	↘

Serie	76.6
Total	0.0

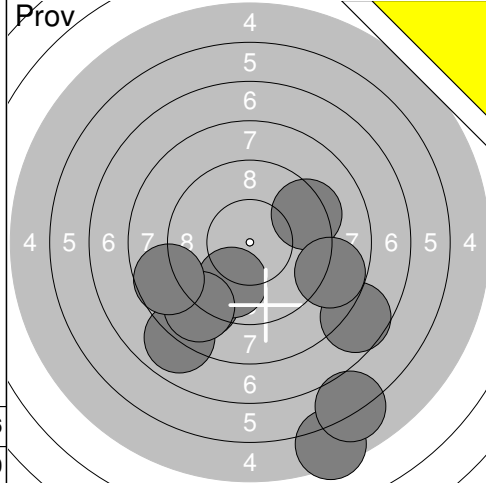

11:	5.4	↘
12:	6.1	↘
13:	9.3	→
14:	7.6	↘
15:	9.0	↘
16:	7.9	↘
17:	9.8	↘
18:	8.8	→
19:	8.9	↘
20:	8.7	←

Serie	81.5
Total	0.0

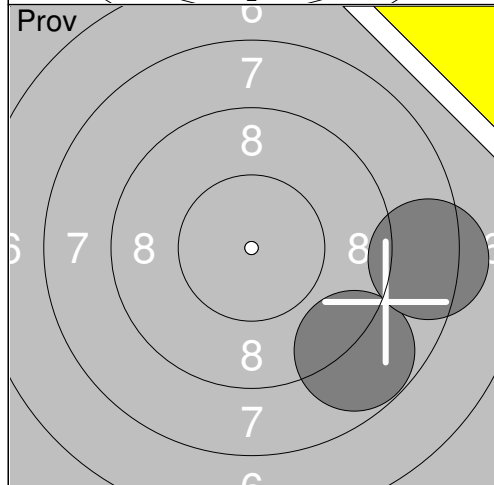

21:	8.8	↘
22:	8.3	→

Serie	17.1
Total	0.0

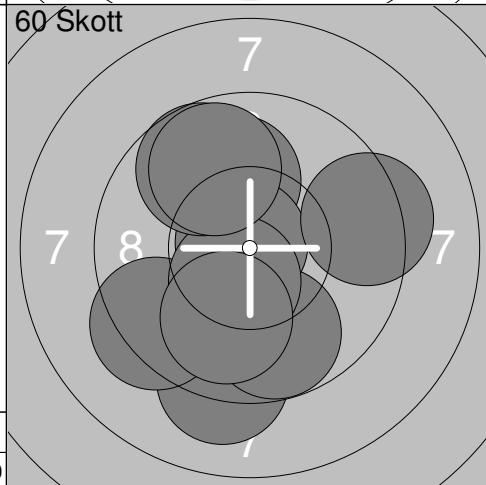

1:	9.2	↘
2:	9.8	↘
3:	9.3	↘
4:	10.0	↗
5:	10.8x	↗
6:	10.5x	↘
7:	9.7	↗
8:	9.3	→
9:	10.0	↘
10:	9.8	↗

Serie	98.4
Total	98.4

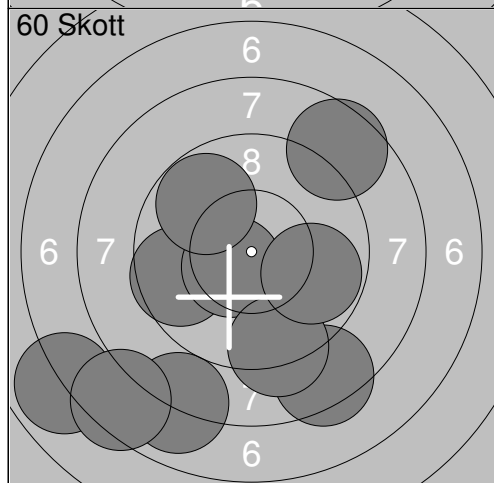

11:	8.4	↘
12:	9.6	←
13:	8.6	↗
14:	10.5x	↘
15:	9.2	↘
16:	9.8	↗
17:	9.8	↘
18:	8.0	↘
19:	6.9	↘
20:	7.4	↘

Serie	88.2
Total	186.6

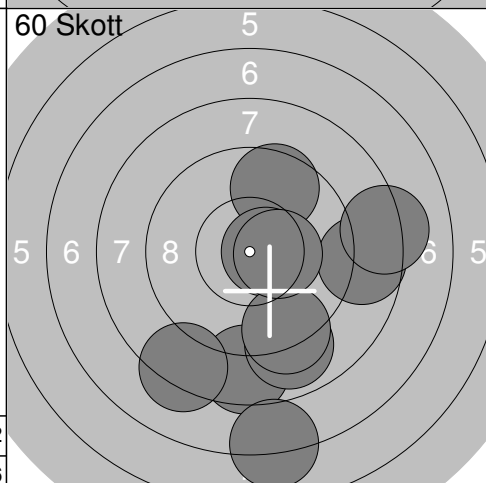

21:	8.6	↘
22:	7.0	↘
23:	8.7	→
24:	8.2	→
25:	8.9	↘
26:	9.6	↗
27:	10.6x	→
28:	9.2	↘
29:	8.3	↘
30:	10.4x	→

Serie	89.5
Total	276.1

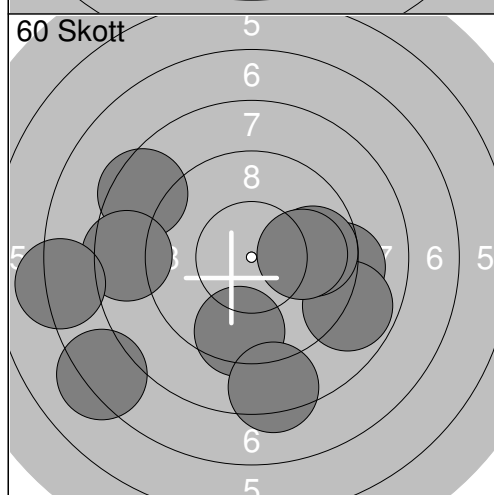

31:	8.5	↗
32:	9.5	↘
33:	8.4	↘
34:	9.2	→
35:	8.8	↘
36:	9.7	→
37:	8.5	←
38:	10.0	→
39:	7.2	↘
40:	7.1	←

Serie	86.9
Total	363.0

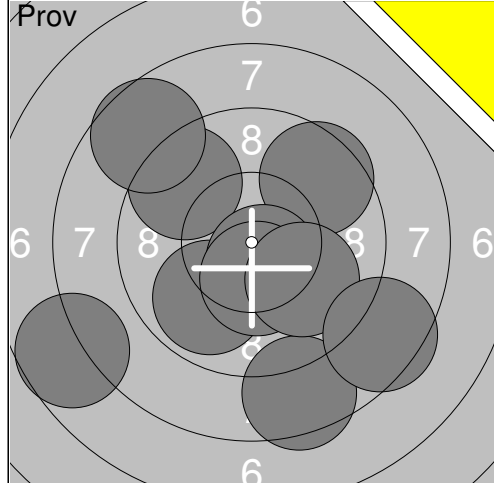

1:	9.5	↗
2:	9.6	↗
3:	9.9	↘
4:	10.6x	↘
5:	10.4x	↘
6:	8.5	↘
7:	7.7	↖
8:	10.0	↘
9:	8.5	↘
10:	8.6	↗
Serie		93.3
Total		0.0

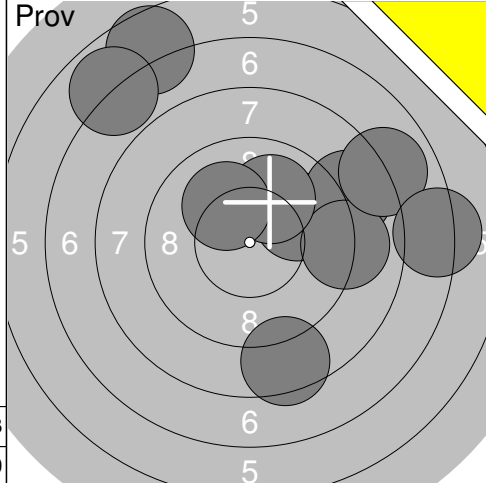

11:	9.9	↗
12:	8.8	↗
13:	9.0	→
14:	6.6	↖
15:	10.0	↖
16:	10.1	↖
17:	7.9	↗
18:	8.5	↘
19:	7.2	→
20:	6.9	↖
Serie		84.9
Total		0.0

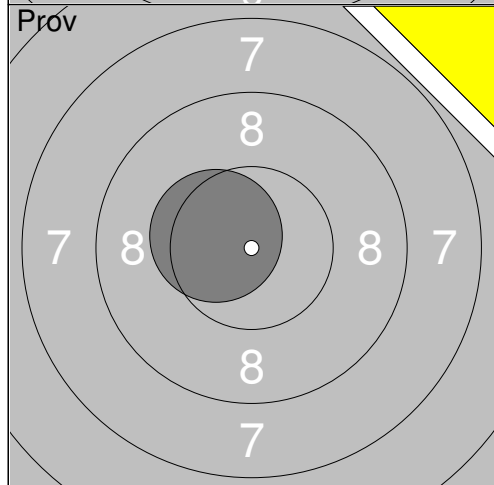

21:	10.4x	↖
Serie		10.4
Total		0.0

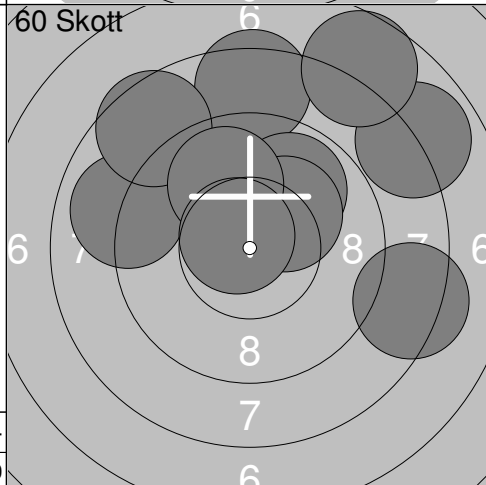

1:	9.0	↖
2:	7.9	↗
3:	8.5	↖
4:	9.9	↖
5:	8.6	↖
6:	10.2x	↗
7:	9.9	↖
8:	7.7	↖
9:	8.3	→
10:	10.7x	↖
Serie		90.7
Total		90.7

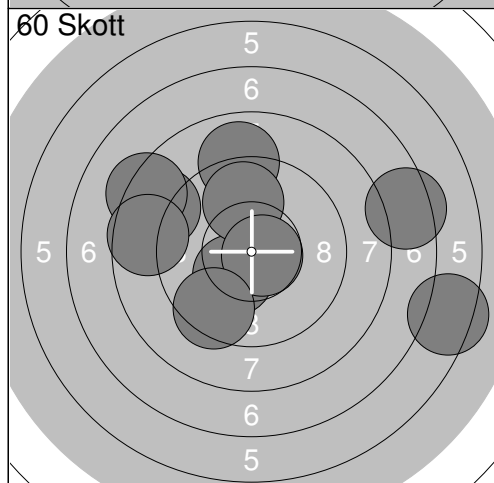

11:	7.4	→
12:	8.7	↖
13:	10.3x	↘
14:	9.0	↖
15:	6.4	↗
16:	8.3	↖
17:	8.6	↖
18:	9.8	↖
19:	10.7x	↗
20:	9.4	↘
Serie		88.6
Total		179.3

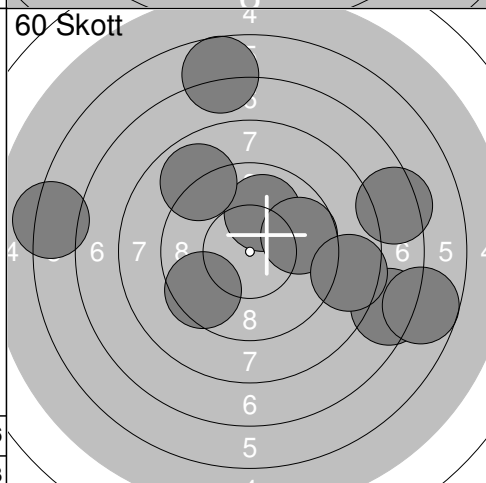

21:	10.0	↖
22:	7.4	→
23:	9.7	→
24:	9.5	↖
25:	6.2	↖
26:	6.7	→
27:	7.4	→
28:	8.9	↖
29:	8.6	→
30:	6.7	↖
Serie		81.1
Total		260.4

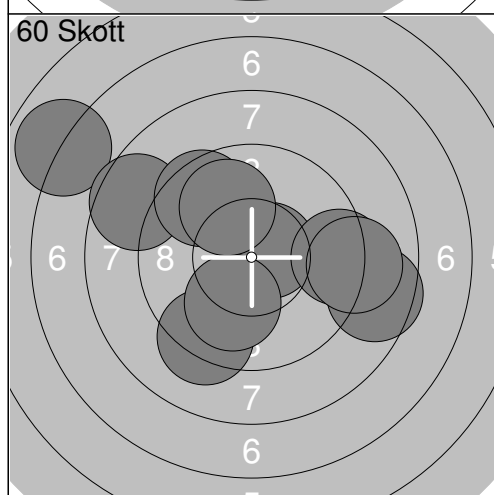

31:	10.6x	↗
32:	9.3	→
33:	8.6	→
34:	9.2	↘
35:	6.9	↖
36:	8.6	↖
37:	10.0	↘
38:	9.5	↖
39:	9.0	→
40:	9.9	↖
Serie		91.6
Total		352.0

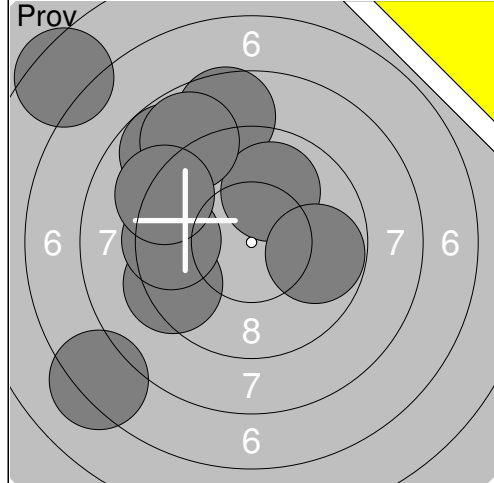

1:	8.8	↗
2:	8.6	↗
3:	10.0	↗
4:	9.4	↖
5:	9.5	↖
6:	8.8	↗
7:	9.8	→
8:	9.2	↗
9:	7.2	↖
10:	6.4	↗
Serie		87.7
Total		0.0

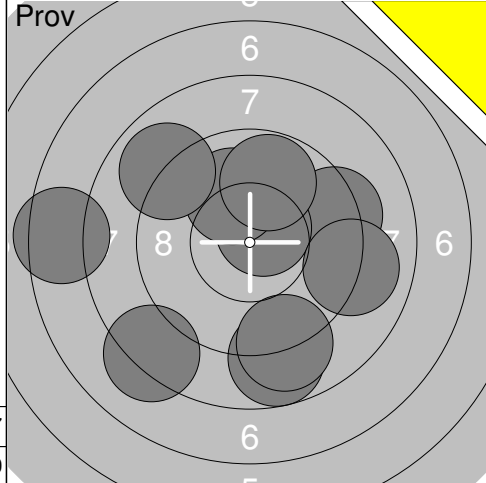

11:	8.7	↘
12:	9.3	→
13:	8.2	↘
14:	10.6x	↗
15:	10.0	↗
16:	9.0	→
17:	7.5	↖
18:	9.8	↗
19:	8.9	↗
20:	9.0	↘
Serie		91.0
Total		0.0

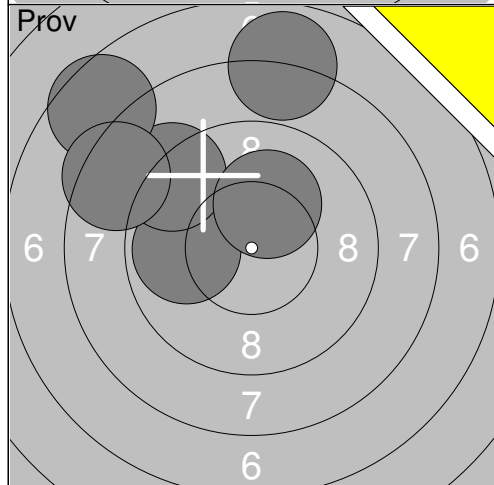

21:	9.9	↖
22:	9.2	↗
23:	7.6	↗
24:	8.4	↗
25:	10.2x	↗
26:	7.9	↗
Serie		53.2
Total		0.0

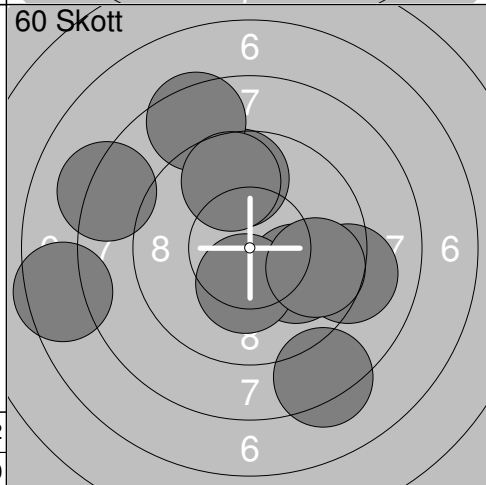

1:	9.7	↗
2:	8.2	↖
3:	10.0	↘
4:	8.5	↗
5:	7.5	↖
6:	10.3x	↘
7:	9.1	→
8:	9.7	→
9:	8.3	↘
10:	9.7	↗
Serie		91.0
Total		91.0

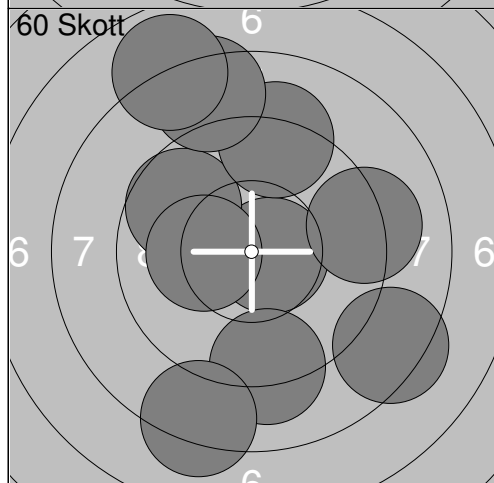

11:	8.3	↘
12:	10.7x	→
13:	9.7	↗
14:	10.2x	↖
15:	9.2	↗
16:	8.4	↗
17:	7.9	↗
18:	9.2	→
19:	9.2	↘
20:	8.2	↘
Serie		91.0
Total		182.0

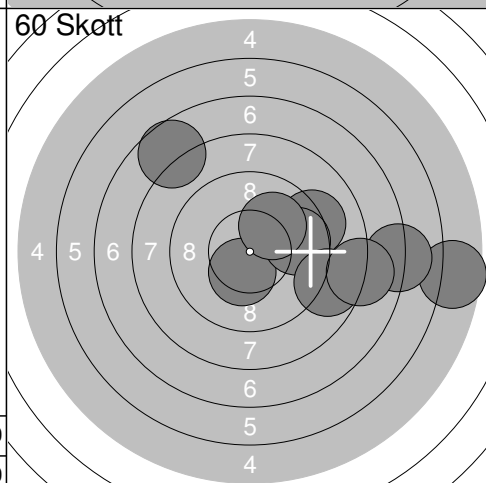

21:	10.4x	↘
22:	9.6	→
23:	9.2	→
24:	5.6	→
25:	9.7	→
26:	10.0	↗
27:	7.7	↗
28:	8.7	→
29:	7.0	→
30:	8.0	→
Serie		85.9
Total		267.9

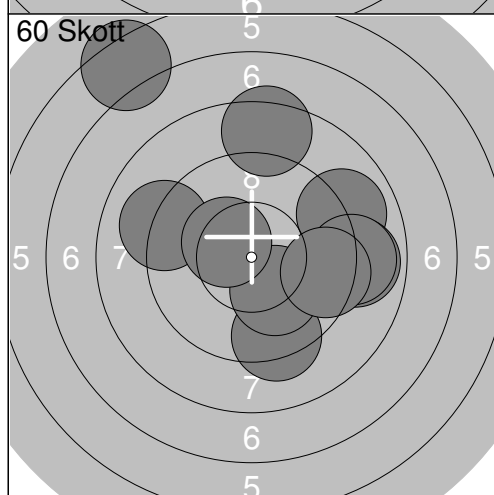

31:	9.0	→
32:	8.9	→
33:	9.1	↗
34:	6.4	↗
35:	9.3	↘
36:	9.0	→
37:	10.1	↘
38:	9.4	→
39:	10.4x	↗
40:	8.4	↗
Serie		90.0
Total		357.9

<p>Pröv</p>	<table border="1" style="width:100%; border-collapse: collapse;"> <tr><td>1:</td><td>8.5</td><td>↗</td></tr> <tr><td>2:</td><td>8.5</td><td>↗</td></tr> <tr><td>3:</td><td>9.6</td><td>→</td></tr> <tr><td>4:</td><td>9.4</td><td>↗</td></tr> <tr><td>5:</td><td>9.7</td><td>↗</td></tr> <tr><td>6:</td><td>10.4x</td><td>↙</td></tr> <tr><td>7:</td><td>10.2x</td><td>←</td></tr> <tr><td>8:</td><td>10.4x</td><td>↗</td></tr> <tr><td>9:</td><td>10.1</td><td>↓</td></tr> <tr><td>10:</td><td>10.7x</td><td>↓</td></tr> <tr><td colspan="2">Serie</td><td style="text-align: right;">97.5</td></tr> <tr><td colspan="2">Total</td><td style="text-align: right;">0.0</td></tr> </table>	1:	8.5	↗	2:	8.5	↗	3:	9.6	→	4:	9.4	↗	5:	9.7	↗	6:	10.4x	↙	7:	10.2x	←	8:	10.4x	↗	9:	10.1	↓	10:	10.7x	↓	Serie		97.5	Total		0.0	<p>Pröv</p>	<table border="1" style="width:100%; border-collapse: collapse;"> <tr><td>11:</td><td>10.2x</td><td>↓</td></tr> <tr><td>12:</td><td>10.9x</td><td>←</td></tr> <tr><td>13:</td><td>10.5x</td><td>↙</td></tr> <tr><td>14:</td><td>10.8x</td><td>↙</td></tr> <tr><td>15:</td><td>10.0</td><td>←</td></tr> <tr><td>16:</td><td>10.1</td><td>←</td></tr> <tr><td>17:</td><td>9.9</td><td>↙</td></tr> <tr><td>18:</td><td>10.7x</td><td>↙</td></tr> <tr><td>19:</td><td>9.9</td><td>↓</td></tr> <tr><td>20:</td><td>9.9</td><td>↘</td></tr> <tr><td colspan="2">Serie</td><td style="text-align: right;">102.9</td></tr> <tr><td colspan="2">Total</td><td style="text-align: right;">0.0</td></tr> </table>	11:	10.2x	↓	12:	10.9x	←	13:	10.5x	↙	14:	10.8x	↙	15:	10.0	←	16:	10.1	←	17:	9.9	↙	18:	10.7x	↙	19:	9.9	↓	20:	9.9	↘	Serie		102.9	Total		0.0
1:	8.5	↗																																																																									
2:	8.5	↗																																																																									
3:	9.6	→																																																																									
4:	9.4	↗																																																																									
5:	9.7	↗																																																																									
6:	10.4x	↙																																																																									
7:	10.2x	←																																																																									
8:	10.4x	↗																																																																									
9:	10.1	↓																																																																									
10:	10.7x	↓																																																																									
Serie		97.5																																																																									
Total		0.0																																																																									
11:	10.2x	↓																																																																									
12:	10.9x	←																																																																									
13:	10.5x	↙																																																																									
14:	10.8x	↙																																																																									
15:	10.0	←																																																																									
16:	10.1	←																																																																									
17:	9.9	↙																																																																									
18:	10.7x	↙																																																																									
19:	9.9	↓																																																																									
20:	9.9	↘																																																																									
Serie		102.9																																																																									
Total		0.0																																																																									
<p>Pröv</p>	<table border="1" style="width:100%; border-collapse: collapse;"> <tr><td>21:</td><td>10.7x</td><td>↘</td></tr> <tr><td>22:</td><td>9.7</td><td>↓</td></tr> <tr><td colspan="2">Serie</td><td style="text-align: right;">20.4</td></tr> <tr><td colspan="2">Total</td><td style="text-align: right;">0.0</td></tr> </table>	21:	10.7x	↘	22:	9.7	↓	Serie		20.4	Total		0.0	<p>60 Skott</p>	<table border="1" style="width:100%; border-collapse: collapse;"> <tr><td>1:</td><td>10.1</td><td>↓</td></tr> <tr><td>2:</td><td>10.9x</td><td>↗</td></tr> <tr><td>3:</td><td>9.8</td><td>↙</td></tr> <tr><td>4:</td><td>10.2x</td><td>→</td></tr> <tr><td>5:</td><td>10.6x</td><td>↙</td></tr> <tr><td>6:</td><td>10.5x</td><td>←</td></tr> <tr><td>7:</td><td>9.8</td><td>↙</td></tr> <tr><td>8:</td><td>10.3x</td><td>↙</td></tr> <tr><td>9:</td><td>10.5x</td><td>↙</td></tr> <tr><td>10:</td><td>10.1</td><td>←</td></tr> <tr><td colspan="2">Serie</td><td style="text-align: right;">102.8</td></tr> <tr><td colspan="2">Total</td><td style="text-align: right;">102.8</td></tr> </table>	1:	10.1	↓	2:	10.9x	↗	3:	9.8	↙	4:	10.2x	→	5:	10.6x	↙	6:	10.5x	←	7:	9.8	↙	8:	10.3x	↙	9:	10.5x	↙	10:	10.1	←	Serie		102.8	Total		102.8																								
21:	10.7x	↘																																																																									
22:	9.7	↓																																																																									
Serie		20.4																																																																									
Total		0.0																																																																									
1:	10.1	↓																																																																									
2:	10.9x	↗																																																																									
3:	9.8	↙																																																																									
4:	10.2x	→																																																																									
5:	10.6x	↙																																																																									
6:	10.5x	←																																																																									
7:	9.8	↙																																																																									
8:	10.3x	↙																																																																									
9:	10.5x	↙																																																																									
10:	10.1	←																																																																									
Serie		102.8																																																																									
Total		102.8																																																																									
<p>60 Skott</p>	<table border="1" style="width:100%; border-collapse: collapse;"> <tr><td>11:</td><td>10.4x</td><td>↙</td></tr> <tr><td>12:</td><td>10.1</td><td>↓</td></tr> <tr><td>13:</td><td>10.7x</td><td>↙</td></tr> <tr><td>14:</td><td>10.6x</td><td>←</td></tr> <tr><td>15:</td><td>10.8x</td><td>→</td></tr> <tr><td>16:</td><td>10.2x</td><td>↙</td></tr> <tr><td>17:</td><td>10.3x</td><td>→</td></tr> <tr><td>18:</td><td>10.7x</td><td>↙</td></tr> <tr><td>19:</td><td>10.5x</td><td>→</td></tr> <tr><td>20:</td><td>10.6x</td><td>↗</td></tr> <tr><td colspan="2">Serie</td><td style="text-align: right;">104.9</td></tr> <tr><td colspan="2">Total</td><td style="text-align: right;">207.7</td></tr> </table>	11:	10.4x	↙	12:	10.1	↓	13:	10.7x	↙	14:	10.6x	←	15:	10.8x	→	16:	10.2x	↙	17:	10.3x	→	18:	10.7x	↙	19:	10.5x	→	20:	10.6x	↗	Serie		104.9	Total		207.7	<p>60 Skott</p>	<table border="1" style="width:100%; border-collapse: collapse;"> <tr><td>21:</td><td>10.5x</td><td>↖</td></tr> <tr><td>22:</td><td>9.8</td><td>↑</td></tr> <tr><td>23:</td><td>10.2x</td><td>↗</td></tr> <tr><td>24:</td><td>10.4x</td><td>→</td></tr> <tr><td>25:</td><td>10.0</td><td>↓</td></tr> <tr><td>26:</td><td>10.8x</td><td>↗</td></tr> <tr><td>27:</td><td>10.5x</td><td>→</td></tr> <tr><td>28:</td><td>10.5x</td><td>↗</td></tr> <tr><td>29:</td><td>10.5x</td><td>↑</td></tr> <tr><td>30:</td><td>10.8x</td><td>↙</td></tr> <tr><td colspan="2">Serie</td><td style="text-align: right;">104.0</td></tr> <tr><td colspan="2">Total</td><td style="text-align: right;">311.7</td></tr> </table>	21:	10.5x	↖	22:	9.8	↑	23:	10.2x	↗	24:	10.4x	→	25:	10.0	↓	26:	10.8x	↗	27:	10.5x	→	28:	10.5x	↗	29:	10.5x	↑	30:	10.8x	↙	Serie		104.0	Total		311.7
11:	10.4x	↙																																																																									
12:	10.1	↓																																																																									
13:	10.7x	↙																																																																									
14:	10.6x	←																																																																									
15:	10.8x	→																																																																									
16:	10.2x	↙																																																																									
17:	10.3x	→																																																																									
18:	10.7x	↙																																																																									
19:	10.5x	→																																																																									
20:	10.6x	↗																																																																									
Serie		104.9																																																																									
Total		207.7																																																																									
21:	10.5x	↖																																																																									
22:	9.8	↑																																																																									
23:	10.2x	↗																																																																									
24:	10.4x	→																																																																									
25:	10.0	↓																																																																									
26:	10.8x	↗																																																																									
27:	10.5x	→																																																																									
28:	10.5x	↗																																																																									
29:	10.5x	↑																																																																									
30:	10.8x	↙																																																																									
Serie		104.0																																																																									
Total		311.7																																																																									
<p>60 Skott</p>	<table border="1" style="width:100%; border-collapse: collapse;"> <tr><td>31:</td><td>10.4x</td><td>↓</td></tr> <tr><td>32:</td><td>10.2x</td><td>↘</td></tr> <tr><td>33:</td><td>10.7x</td><td>←</td></tr> <tr><td>34:</td><td>10.6x</td><td>↗</td></tr> <tr><td>35:</td><td>10.5x</td><td>↗</td></tr> <tr><td>36:</td><td>10.1</td><td>↑</td></tr> <tr><td>37:</td><td>10.2x</td><td>↑</td></tr> <tr><td>38:</td><td>10.7x</td><td>↗</td></tr> <tr><td>39:</td><td>10.1</td><td>←</td></tr> <tr><td>40:</td><td>9.6</td><td>↗</td></tr> <tr><td colspan="2">Serie</td><td style="text-align: right;">103.1</td></tr> <tr><td colspan="2">Total</td><td style="text-align: right;">414.8</td></tr> </table>	31:	10.4x	↓	32:	10.2x	↘	33:	10.7x	←	34:	10.6x	↗	35:	10.5x	↗	36:	10.1	↑	37:	10.2x	↑	38:	10.7x	↗	39:	10.1	←	40:	9.6	↗	Serie		103.1	Total		414.8																																						
31:	10.4x	↓																																																																									
32:	10.2x	↘																																																																									
33:	10.7x	←																																																																									
34:	10.6x	↗																																																																									
35:	10.5x	↗																																																																									
36:	10.1	↑																																																																									
37:	10.2x	↑																																																																									
38:	10.7x	↗																																																																									
39:	10.1	←																																																																									
40:	9.6	↗																																																																									
Serie		103.1																																																																									
Total		414.8																																																																									

<p>Prov</p>	<table border="1" style="width:100%; border-collapse: collapse;"> <tr><td>1:</td><td>8.7</td><td>↙</td></tr> <tr><td>2:</td><td>8.9</td><td>↙</td></tr> <tr><td>3:</td><td>9.5</td><td>➡</td></tr> <tr><td>4:</td><td>10.4x</td><td>↘</td></tr> <tr><td>5:</td><td>10.0</td><td>↘</td></tr> <tr><td>6:</td><td>10.0</td><td>↘</td></tr> <tr><td>7:</td><td>10.6x</td><td>↗</td></tr> <tr><td>8:</td><td>10.7x</td><td>↖</td></tr> <tr><td>9:</td><td>10.0</td><td>↗</td></tr> <tr><td>10:</td><td>10.8x</td><td>↘</td></tr> <tr><td colspan="2">Serie</td><td>99.6</td></tr> <tr><td colspan="2">Total</td><td>0.0</td></tr> </table>	1:	8.7	↙	2:	8.9	↙	3:	9.5	➡	4:	10.4x	↘	5:	10.0	↘	6:	10.0	↘	7:	10.6x	↗	8:	10.7x	↖	9:	10.0	↗	10:	10.8x	↘	Serie		99.6	Total		0.0	<p>Prov</p>	<table border="1" style="width:100%; border-collapse: collapse;"> <tr><td>11:</td><td>9.9</td><td>↙</td></tr> <tr><td>13:</td><td>9.9</td><td>↘</td></tr> <tr><td>14:</td><td>10.0</td><td>↘</td></tr> <tr><td>15:</td><td>10.1</td><td>➡</td></tr> <tr><td>16:</td><td>10.4x</td><td>↖</td></tr> <tr><td>17:</td><td>10.6x</td><td>↘</td></tr> <tr><td>18:</td><td>10.7x</td><td>↖</td></tr> <tr><td>19:</td><td>10.2x</td><td>↗</td></tr> <tr><td>20:</td><td>9.6</td><td>➡</td></tr> <tr><td colspan="2">Serie</td><td>91.4</td></tr> <tr><td colspan="2">Total</td><td>0.0</td></tr> </table>	11:	9.9	↙	13:	9.9	↘	14:	10.0	↘	15:	10.1	➡	16:	10.4x	↖	17:	10.6x	↘	18:	10.7x	↖	19:	10.2x	↗	20:	9.6	➡	Serie		91.4	Total		0.0			
1:	8.7	↙																																																																									
2:	8.9	↙																																																																									
3:	9.5	➡																																																																									
4:	10.4x	↘																																																																									
5:	10.0	↘																																																																									
6:	10.0	↘																																																																									
7:	10.6x	↗																																																																									
8:	10.7x	↖																																																																									
9:	10.0	↗																																																																									
10:	10.8x	↘																																																																									
Serie		99.6																																																																									
Total		0.0																																																																									
11:	9.9	↙																																																																									
13:	9.9	↘																																																																									
14:	10.0	↘																																																																									
15:	10.1	➡																																																																									
16:	10.4x	↖																																																																									
17:	10.6x	↘																																																																									
18:	10.7x	↖																																																																									
19:	10.2x	↗																																																																									
20:	9.6	➡																																																																									
Serie		91.4																																																																									
Total		0.0																																																																									
<p>Prov</p>	<table border="1" style="width:100%; border-collapse: collapse;"> <tr><td>21:</td><td>9.8</td><td>↘</td></tr> <tr><td>22:</td><td>10.0</td><td>↗</td></tr> <tr><td colspan="2">Serie</td><td>19.8</td></tr> <tr><td colspan="2">Total</td><td>0.0</td></tr> </table>	21:	9.8	↘	22:	10.0	↗	Serie		19.8	Total		0.0	<p>60 Skott</p>	<table border="1" style="width:100%; border-collapse: collapse;"> <tr><td>1:</td><td>9.7</td><td>↗</td></tr> <tr><td>2:</td><td>10.3x</td><td>➡</td></tr> <tr><td>3:</td><td>10.6x</td><td>↘</td></tr> <tr><td>4:</td><td>10.5x</td><td>↖</td></tr> <tr><td>5:</td><td>10.8x</td><td>↖</td></tr> <tr><td>6:</td><td>9.7</td><td>↗</td></tr> <tr><td>7:</td><td>10.3x</td><td>↗</td></tr> <tr><td>8:</td><td>10.3x</td><td>➡</td></tr> <tr><td>9:</td><td>10.7x</td><td>➡</td></tr> <tr><td>10:</td><td>10.1</td><td>↗</td></tr> <tr><td colspan="2">Serie</td><td>103.0</td></tr> <tr><td colspan="2">Total</td><td>103.0</td></tr> </table>	1:	9.7	↗	2:	10.3x	➡	3:	10.6x	↘	4:	10.5x	↖	5:	10.8x	↖	6:	9.7	↗	7:	10.3x	↗	8:	10.3x	➡	9:	10.7x	➡	10:	10.1	↗	Serie		103.0	Total		103.0																								
21:	9.8	↘																																																																									
22:	10.0	↗																																																																									
Serie		19.8																																																																									
Total		0.0																																																																									
1:	9.7	↗																																																																									
2:	10.3x	➡																																																																									
3:	10.6x	↘																																																																									
4:	10.5x	↖																																																																									
5:	10.8x	↖																																																																									
6:	9.7	↗																																																																									
7:	10.3x	↗																																																																									
8:	10.3x	➡																																																																									
9:	10.7x	➡																																																																									
10:	10.1	↗																																																																									
Serie		103.0																																																																									
Total		103.0																																																																									
<p>60 Skott</p>	<table border="1" style="width:100%; border-collapse: collapse;"> <tr><td>11:</td><td>10.0</td><td>↖</td></tr> <tr><td>12:</td><td>10.4x</td><td>➡</td></tr> <tr><td>13:</td><td>10.2x</td><td>➡</td></tr> <tr><td>14:</td><td>10.1</td><td>↘</td></tr> <tr><td>15:</td><td>10.7x</td><td>↘</td></tr> <tr><td>16:</td><td>10.0</td><td>↘</td></tr> <tr><td>17:</td><td>10.9x</td><td>↗</td></tr> <tr><td>18:</td><td>9.9</td><td>↘</td></tr> <tr><td>19:</td><td>9.8</td><td>↗</td></tr> <tr><td>20:</td><td>10.7x</td><td>↘</td></tr> <tr><td colspan="2">Serie</td><td>102.7</td></tr> <tr><td colspan="2">Total</td><td>205.7</td></tr> </table>	11:	10.0	↖	12:	10.4x	➡	13:	10.2x	➡	14:	10.1	↘	15:	10.7x	↘	16:	10.0	↘	17:	10.9x	↗	18:	9.9	↘	19:	9.8	↗	20:	10.7x	↘	Serie		102.7	Total		205.7	<p>60 Skott</p>	<table border="1" style="width:100%; border-collapse: collapse;"> <tr><td>21:</td><td>9.6</td><td>↗</td></tr> <tr><td>22:</td><td>10.5x</td><td>↑</td></tr> <tr><td>23:</td><td>8.9</td><td>↖</td></tr> <tr><td>24:</td><td>10.1</td><td>↘</td></tr> <tr><td>25:</td><td>10.1</td><td>↖</td></tr> <tr><td>26:</td><td>10.2x</td><td>↗</td></tr> <tr><td>27:</td><td>9.8</td><td>↘</td></tr> <tr><td>28:</td><td>10.5x</td><td>↖</td></tr> <tr><td>29:</td><td>9.9</td><td>↖</td></tr> <tr><td>30:</td><td>10.6x</td><td>↗</td></tr> <tr><td colspan="2">Serie</td><td>100.2</td></tr> <tr><td colspan="2">Total</td><td>305.9</td></tr> </table>	21:	9.6	↗	22:	10.5x	↑	23:	8.9	↖	24:	10.1	↘	25:	10.1	↖	26:	10.2x	↗	27:	9.8	↘	28:	10.5x	↖	29:	9.9	↖	30:	10.6x	↗	Serie		100.2	Total		305.9
11:	10.0	↖																																																																									
12:	10.4x	➡																																																																									
13:	10.2x	➡																																																																									
14:	10.1	↘																																																																									
15:	10.7x	↘																																																																									
16:	10.0	↘																																																																									
17:	10.9x	↗																																																																									
18:	9.9	↘																																																																									
19:	9.8	↗																																																																									
20:	10.7x	↘																																																																									
Serie		102.7																																																																									
Total		205.7																																																																									
21:	9.6	↗																																																																									
22:	10.5x	↑																																																																									
23:	8.9	↖																																																																									
24:	10.1	↘																																																																									
25:	10.1	↖																																																																									
26:	10.2x	↗																																																																									
27:	9.8	↘																																																																									
28:	10.5x	↖																																																																									
29:	9.9	↖																																																																									
30:	10.6x	↗																																																																									
Serie		100.2																																																																									
Total		305.9																																																																									
<p>60 Skott</p>	<table border="1" style="width:100%; border-collapse: collapse;"> <tr><td>31:</td><td>10.0</td><td>↗</td></tr> <tr><td>32:</td><td>9.7</td><td>↘</td></tr> <tr><td>33:</td><td>10.4x</td><td>➡</td></tr> <tr><td>34:</td><td>10.0</td><td>↑</td></tr> <tr><td>35:</td><td>10.8x</td><td>➡</td></tr> <tr><td>36:</td><td>9.8</td><td>↘</td></tr> <tr><td>37:</td><td>9.7</td><td>↖</td></tr> <tr><td>38:</td><td>10.3x</td><td>↘</td></tr> <tr><td>39:</td><td>10.5x</td><td>↖</td></tr> <tr><td>40:</td><td>10.5x</td><td>↗</td></tr> <tr><td colspan="2">Serie</td><td>101.7</td></tr> <tr><td colspan="2">Total</td><td>407.6</td></tr> </table>	31:	10.0	↗	32:	9.7	↘	33:	10.4x	➡	34:	10.0	↑	35:	10.8x	➡	36:	9.8	↘	37:	9.7	↖	38:	10.3x	↘	39:	10.5x	↖	40:	10.5x	↗	Serie		101.7	Total		407.6																																						
31:	10.0	↗																																																																									
32:	9.7	↘																																																																									
33:	10.4x	➡																																																																									
34:	10.0	↑																																																																									
35:	10.8x	➡																																																																									
36:	9.8	↘																																																																									
37:	9.7	↖																																																																									
38:	10.3x	↘																																																																									
39:	10.5x	↖																																																																									
40:	10.5x	↗																																																																									
Serie		101.7																																																																									
Total		407.6																																																																									

	<p>1: 10.1 ↑</p> <p>2: 10.1 ←</p> <p>3: 10.6 ✕</p> <p>4: 10.1 ↖</p> <p>5: 9.2 ↓</p> <p>6: 10.3 ✕</p> <p>7: 10.6 ✕</p> <p>8: 10.6 ✕</p> <p>9: 10.4 ✕</p> <p>10: 10.6 ✕</p>		<p>11: 10.0 ↓</p> <p>12: 10.7 ✕</p> <p>13: 10.5 ✕</p> <p>14: 10.2 ✕</p> <p>15: 10.6 ✕</p>
Serie 102.6		Serie 52.0	
Total 0.0		Total 0.0	

	<p>1: 10.7 ✕</p> <p>2: 10.8 ✕</p> <p>3: 10.4 ✕</p> <p>4: 10.1 →</p> <p>5: 10.1 →</p> <p>6: 10.2 ✕</p> <p>7: 10.2 ✕</p> <p>8: 10.3 ✕</p> <p>9: 10.4 ✕</p> <p>10: 9.9 ↗</p>		<p>11: 10.8 ✕</p> <p>12: 10.2 ✕</p> <p>13: 9.3 ↗</p> <p>14: 10.2 ✕</p> <p>15: 10.5 ✕</p> <p>16: 10.5 ✕</p> <p>17: 10.5 ✕</p> <p>18: 10.3 ✕</p> <p>19: 10.4 ✕</p> <p>20: 10.6 ✕</p>
Serie 103.1		Serie 103.3	
Total 103.1		Total 206.4	

	<p>21: 10.3 ✕</p> <p>22: 10.4 ✕</p> <p>23: 10.5 ✕</p> <p>24: 9.9 ↗</p> <p>25: 10.6 ✕</p> <p>26: 10.3 ✕</p> <p>27: 10.0 ↗</p> <p>28: 10.8 ✕</p> <p>29: 9.8 ↗</p> <p>30: 10.5 ✕</p>		<p>31: 10.0 ↗</p> <p>32: 10.3 ✕</p> <p>33: 10.5 ✕</p> <p>34: 10.7 ✕</p> <p>35: 10.6 ✕</p> <p>36: 10.1 ↓</p> <p>37: 10.2 ✕</p> <p>38: 9.5 ↗</p> <p>39: 10.0 ↓</p> <p>40: 8.9 ↓</p>
Serie 103.1		Serie 100.8	
Total 309.5		Total 410.3	

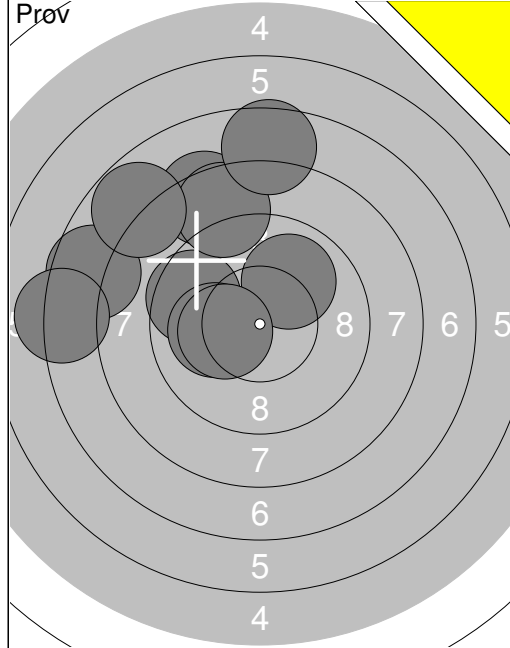

1:	8.3 ↗
2:	9.6 ↖
3:	7.6 ↖
4:	7.2 ↖
5:	10.1 ↖
6:	8.7 ↗
7:	7.6 ↗
8:	7.8 ↖
9:	10.0 ↗
10:	10.3x ↖
Serie	87.2
Total	0.0

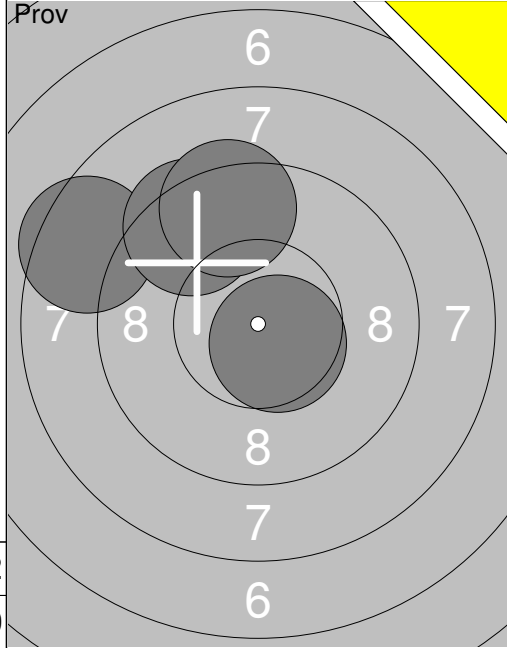

11:	8.5 ↖
12:	9.4 ↗
13:	9.4 ↗
14:	10.6x ↘
Serie	37.9
Total	0.0

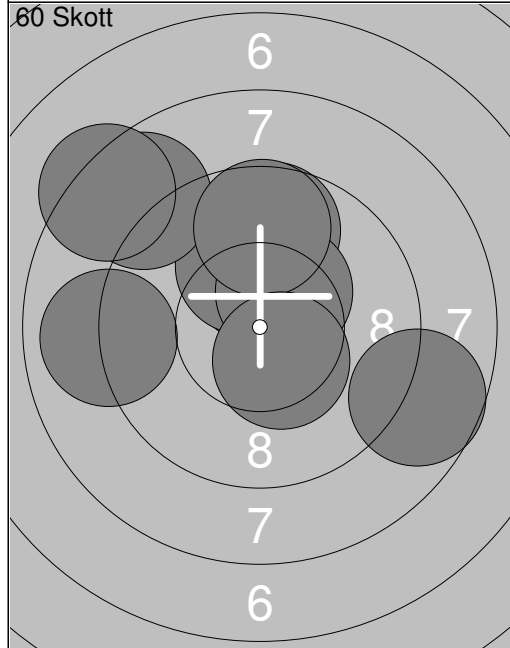

1:	9.0 ↖
2:	10.3x ↗
3:	9.7 ↗
4:	10.1 ↗
5:	8.7 ↖
6:	10.4x ↗
7:	8.3 ↖
8:	9.7 ↗
9:	8.7 ➡
10:	10.4x ↘
Serie	95.3
Total	95.3

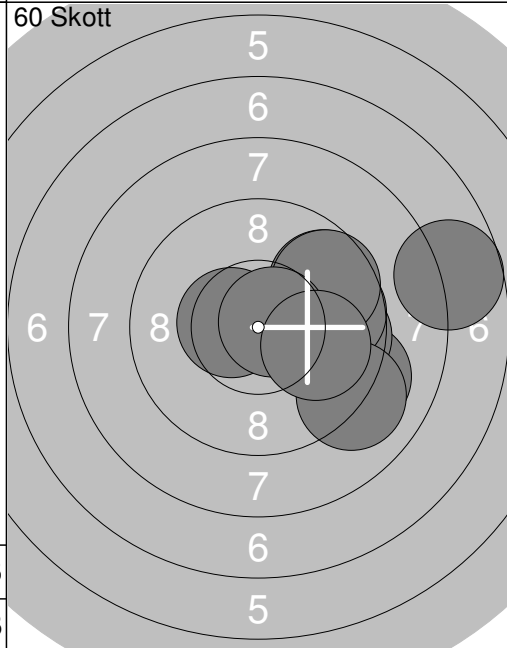

11:	7.7 ➡
12:	9.2 ➡
13:	9.7 ↗
14:	9.7 ➡
15:	10.5x ↖
16:	9.7 ➡
17:	9.7 ↗
18:	9.1 ↘
19:	10.7x ➡
20:	10.0 ➡
Serie	96.0
Total	191.3

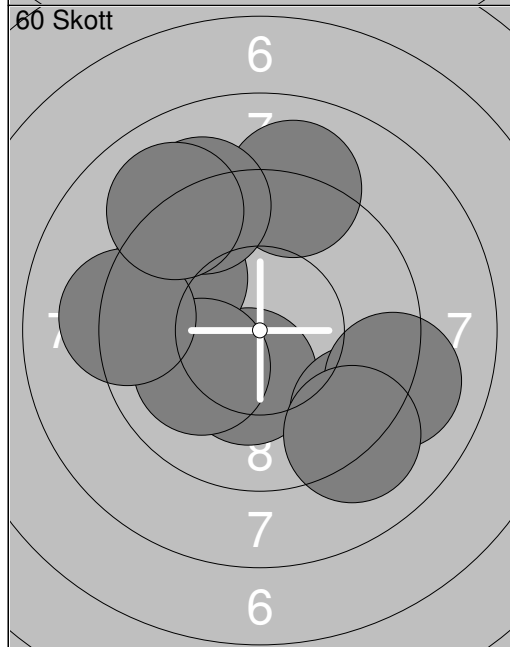

21:	10.3x ↘
22:	9.7 ↖
23:	10.1 ↖
24:	9.3 ↘
25:	9.1 ➡
26:	9.1 ↘
27:	9.1 ↗
28:	9.2 ↗
29:	9.2 ↖
30:	9.0 ↖
Serie	94.1
Total	285.4

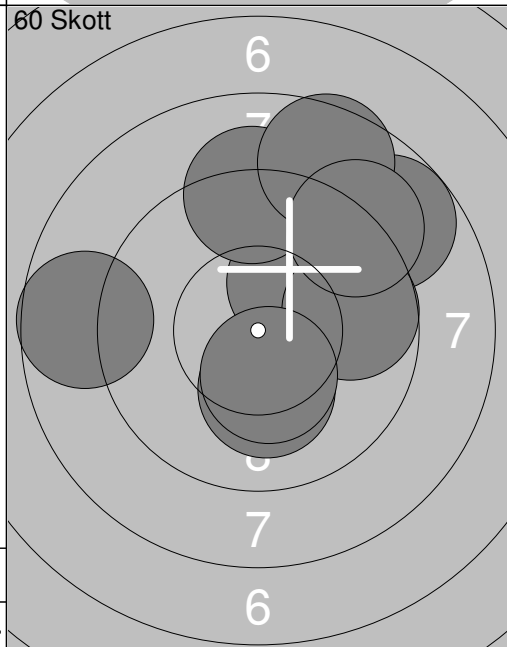

31:	10.2x ↗
32:	8.9 ↗
33:	9.2 ↗
34:	8.7 ↖
35:	8.8 ↗
36:	8.6 ↗
37:	10.2x ↘
38:	9.7 ➡
39:	10.3x ↘
40:	9.1 ↗
Serie	93.7
Total	379.1

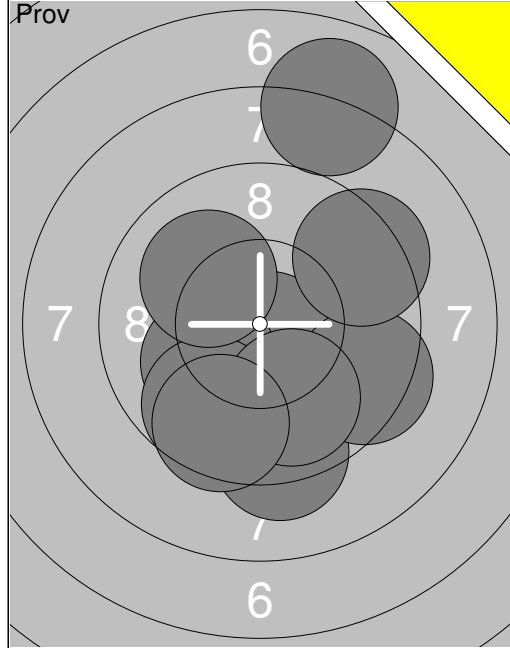

1:	9.3 ↓
2:	10.7x↓
3:	10.1 ↙
4:	9.7 ↓
5:	9.4 →
6:	9.9 ↓
7:	10.1 ↖
8:	9.6 ↓
9:	9.4 ↗
10:	8.0 ↑
Serie	96.2
Total	0.0

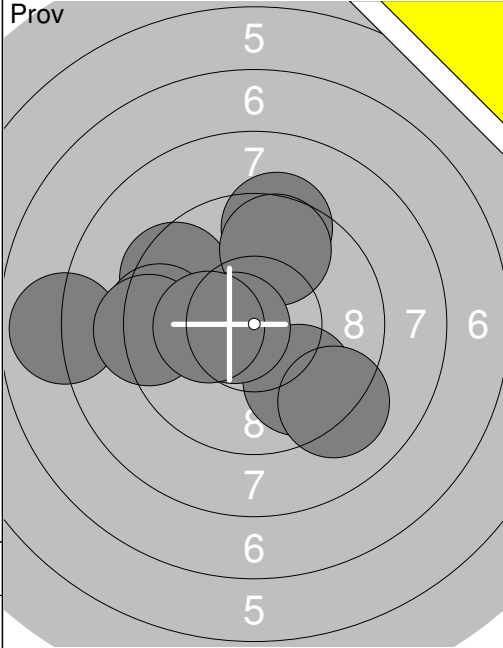

11:	9.8 ↘
12:	7.9 ←
13:	9.5 ↖
14:	9.4 ↑
15:	9.4 ←
16:	9.7 ↑
17:	9.3 ←
18:	10.6x↖
19:	9.2 ↘
20:	10.2x↖
Serie	95.0
Total	0.0

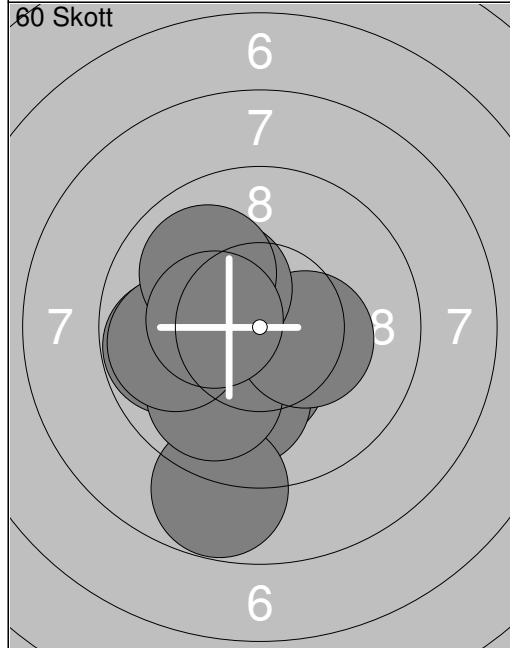

1:	10.3x↓
2:	9.8 ←
3:	10.0 ↓
4:	8.8 ↓
5:	9.9 ↓
6:	10.3x→
7:	9.8 ←
8:	10.3x↖
9:	10.0 ↖
10:	10.4x↖
Serie	99.6
Total	99.6

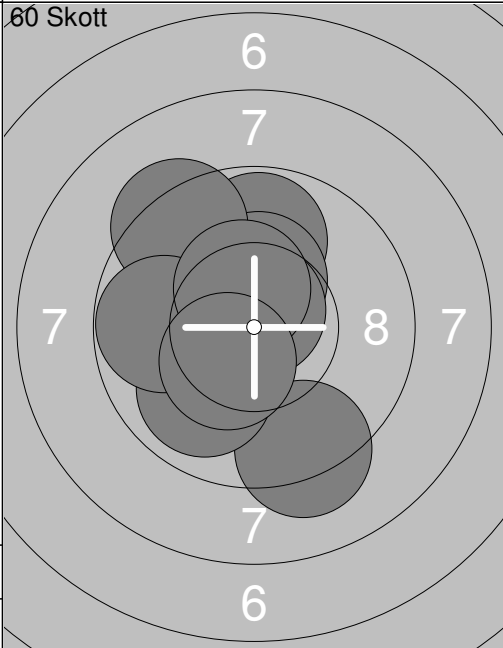

11:	9.2 ↓
12:	10.3x↖
13:	9.9 ↓
14:	9.8 ↑
15:	10.3x↑
16:	9.3 ↖
17:	9.8 ←
18:	10.7x↑
19:	10.4x↑
20:	10.4x↘
Serie	100.1
Total	199.7

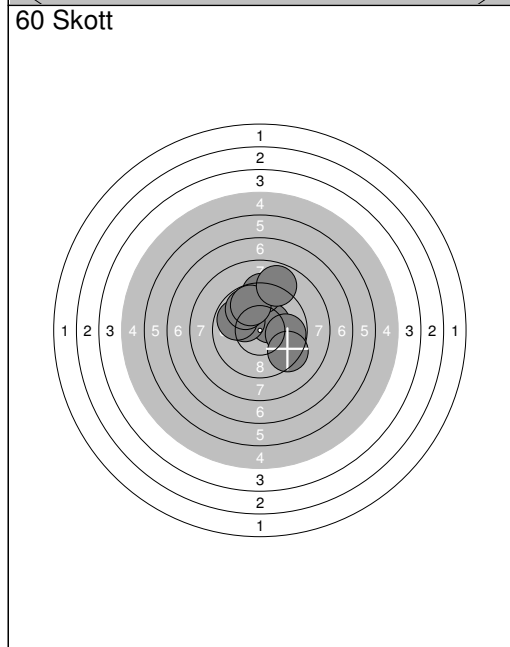

21:	10.4x↗
22:	9.8 →
23:	9.4 ↘
24:	10.2x↖
25:	9.9 ↖
26:	0.0 ↓
27:	9.3 ↑
28:	9.8 ↖
29:	9.8 ↑
30:	8.9 ↑
Serie	87.5
Total	287.2

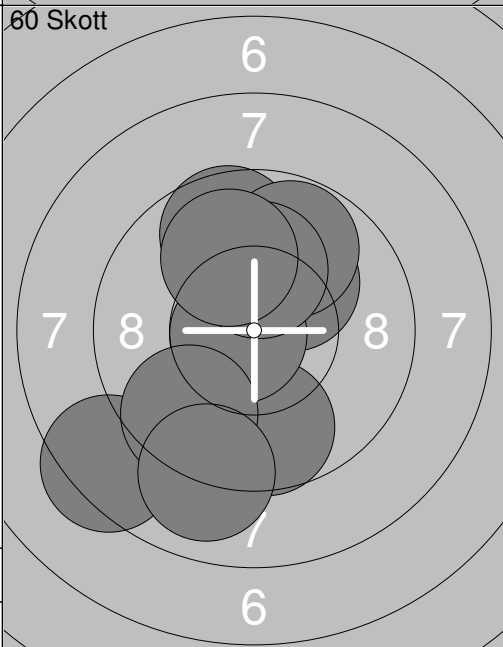

31:	9.7 ↓
32:	10.2x↗
33:	8.4 ↘
34:	10.7x↖
35:	9.6 ↑
36:	9.8 ↗
37:	9.6 ↘
38:	10.2x↑
39:	9.0 ↓
40:	9.9 ↑
Serie	97.1
Total	384.3

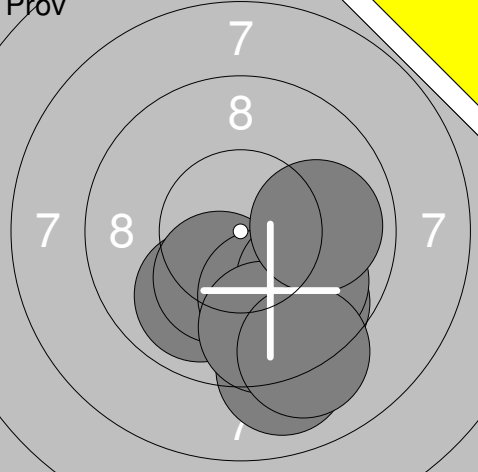
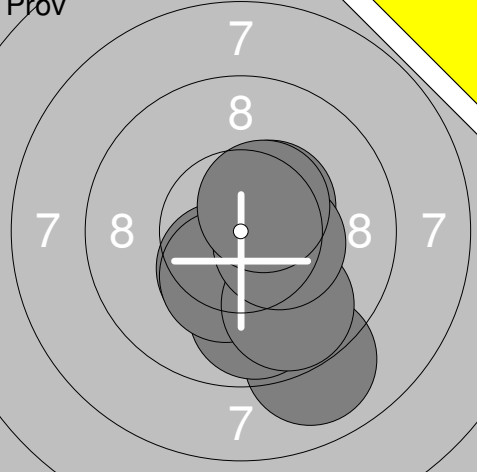
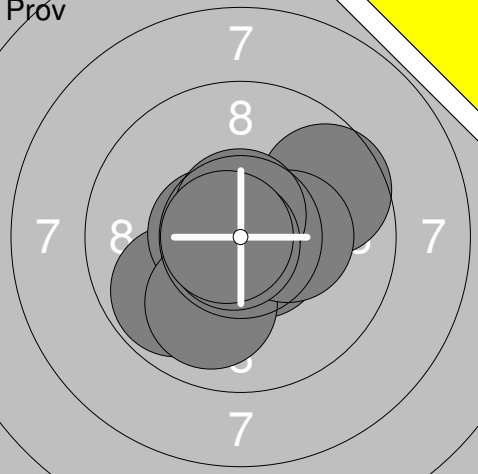
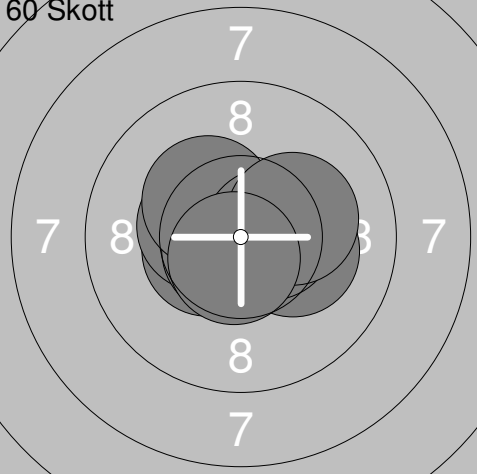
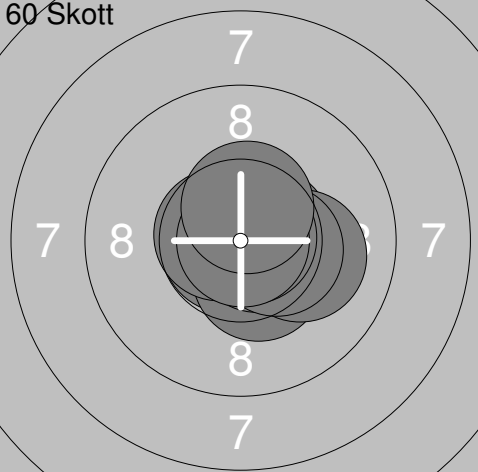
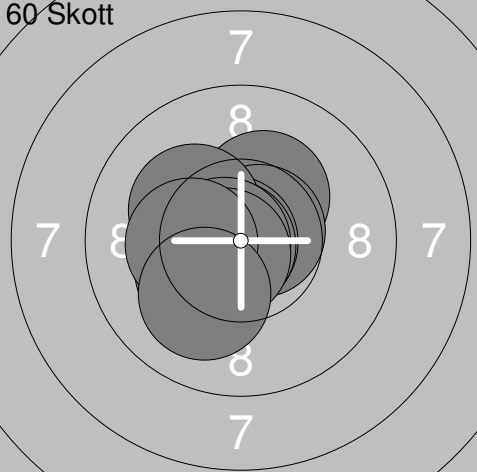
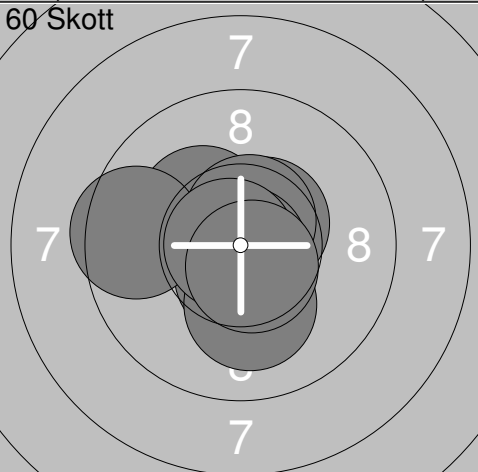
<p>Prov</p> 	<table border="1" style="width:100%; border-collapse: collapse;"> <tr><td>1:</td><td>9.9</td><td>↘</td></tr> <tr><td>2:</td><td>9.9</td><td>↘</td></tr> <tr><td>3:</td><td>10.3x</td><td>↘</td></tr> <tr><td>4:</td><td>9.7</td><td>↘</td></tr> <tr><td>5:</td><td>10.0</td><td>↘</td></tr> <tr><td>6:</td><td>9.9</td><td>↘</td></tr> <tr><td>7:</td><td>9.0</td><td>↘</td></tr> <tr><td>8:</td><td>9.6</td><td>↘</td></tr> <tr><td>9:</td><td>9.1</td><td>↘</td></tr> <tr><td>10:</td><td>9.9</td><td>→</td></tr> <tr><td colspan="2">Serie</td><td>97.3</td></tr> <tr><td colspan="2">Total</td><td>0.0</td></tr> </table>	1:	9.9	↘	2:	9.9	↘	3:	10.3x	↘	4:	9.7	↘	5:	10.0	↘	6:	9.9	↘	7:	9.0	↘	8:	9.6	↘	9:	9.1	↘	10:	9.9	→	Serie		97.3	Total		0.0	<p>Prov</p> 	<table border="1" style="width:100%; border-collapse: collapse;"> <tr><td>11:</td><td>10.5x</td><td>↓</td></tr> <tr><td>12:</td><td>9.0</td><td>↘</td></tr> <tr><td>13:</td><td>9.8</td><td>↘</td></tr> <tr><td>14:</td><td>10.4x</td><td>↘</td></tr> <tr><td>15:</td><td>10.4x</td><td>↗</td></tr> <tr><td>16:</td><td>10.4x</td><td>↘</td></tr> <tr><td>17:</td><td>10.3x</td><td>↘</td></tr> <tr><td>18:</td><td>9.8</td><td>↘</td></tr> <tr><td>19:</td><td>10.4x</td><td>→</td></tr> <tr><td>20:</td><td>10.5x</td><td>↗</td></tr> <tr><td colspan="2">Serie</td><td>101.5</td></tr> <tr><td colspan="2">Total</td><td>0.0</td></tr> </table>	11:	10.5x	↓	12:	9.0	↘	13:	9.8	↘	14:	10.4x	↘	15:	10.4x	↗	16:	10.4x	↘	17:	10.3x	↘	18:	9.8	↘	19:	10.4x	→	20:	10.5x	↗	Serie		101.5	Total		0.0
1:	9.9	↘																																																																									
2:	9.9	↘																																																																									
3:	10.3x	↘																																																																									
4:	9.7	↘																																																																									
5:	10.0	↘																																																																									
6:	9.9	↘																																																																									
7:	9.0	↘																																																																									
8:	9.6	↘																																																																									
9:	9.1	↘																																																																									
10:	9.9	→																																																																									
Serie		97.3																																																																									
Total		0.0																																																																									
11:	10.5x	↓																																																																									
12:	9.0	↘																																																																									
13:	9.8	↘																																																																									
14:	10.4x	↘																																																																									
15:	10.4x	↗																																																																									
16:	10.4x	↘																																																																									
17:	10.3x	↘																																																																									
18:	9.8	↘																																																																									
19:	10.4x	→																																																																									
20:	10.5x	↗																																																																									
Serie		101.5																																																																									
Total		0.0																																																																									
<p>Prov</p> 	<table border="1" style="width:100%; border-collapse: collapse;"> <tr><td>21:</td><td>9.8</td><td>↙</td></tr> <tr><td>22:</td><td>10.8x</td><td>↙</td></tr> <tr><td>23:</td><td>10.6x</td><td>↘</td></tr> <tr><td>24:</td><td>10.6x</td><td>↙</td></tr> <tr><td>25:</td><td>10.0</td><td>↘</td></tr> <tr><td>26:</td><td>9.6</td><td>↗</td></tr> <tr><td>27:</td><td>10.3x</td><td>→</td></tr> <tr><td>28:</td><td>10.6x</td><td>↑</td></tr> <tr><td>29:</td><td>10.8x</td><td>↙</td></tr> <tr><td>30:</td><td>10.8x</td><td>↙</td></tr> <tr><td colspan="2">Serie</td><td>103.9</td></tr> <tr><td colspan="2">Total</td><td>0.0</td></tr> </table>	21:	9.8	↙	22:	10.8x	↙	23:	10.6x	↘	24:	10.6x	↙	25:	10.0	↘	26:	9.6	↗	27:	10.3x	→	28:	10.6x	↑	29:	10.8x	↙	30:	10.8x	↙	Serie		103.9	Total		0.0	<p>60 Skott</p> 	<table border="1" style="width:100%; border-collapse: collapse;"> <tr><td>1:</td><td>10.5x</td><td>↙</td></tr> <tr><td>2:</td><td>10.4x</td><td>↙</td></tr> <tr><td>3:</td><td>10.8x</td><td>↙</td></tr> <tr><td>4:</td><td>10.5x</td><td>→</td></tr> <tr><td>5:</td><td>10.7x</td><td>↙</td></tr> <tr><td>6:</td><td>10.3x</td><td>↗</td></tr> <tr><td>7:</td><td>10.2x</td><td>→</td></tr> <tr><td>8:</td><td>10.6x</td><td>→</td></tr> <tr><td>9:</td><td>10.2x</td><td>→</td></tr> <tr><td>10:</td><td>10.7x</td><td>↓</td></tr> <tr><td colspan="2">Serie</td><td>104.9</td></tr> <tr><td colspan="2">Total</td><td>104.9</td></tr> </table>	1:	10.5x	↙	2:	10.4x	↙	3:	10.8x	↙	4:	10.5x	→	5:	10.7x	↙	6:	10.3x	↗	7:	10.2x	→	8:	10.6x	→	9:	10.2x	→	10:	10.7x	↓	Serie		104.9	Total		104.9
21:	9.8	↙																																																																									
22:	10.8x	↙																																																																									
23:	10.6x	↘																																																																									
24:	10.6x	↙																																																																									
25:	10.0	↘																																																																									
26:	9.6	↗																																																																									
27:	10.3x	→																																																																									
28:	10.6x	↑																																																																									
29:	10.8x	↙																																																																									
30:	10.8x	↙																																																																									
Serie		103.9																																																																									
Total		0.0																																																																									
1:	10.5x	↙																																																																									
2:	10.4x	↙																																																																									
3:	10.8x	↙																																																																									
4:	10.5x	→																																																																									
5:	10.7x	↙																																																																									
6:	10.3x	↗																																																																									
7:	10.2x	→																																																																									
8:	10.6x	→																																																																									
9:	10.2x	→																																																																									
10:	10.7x	↓																																																																									
Serie		104.9																																																																									
Total		104.9																																																																									
<p>60 Skott</p> 	<table border="1" style="width:100%; border-collapse: collapse;"> <tr><td>11:</td><td>10.8x</td><td>↙</td></tr> <tr><td>12:</td><td>10.4x</td><td>↘</td></tr> <tr><td>13:</td><td>10.7x</td><td>↘</td></tr> <tr><td>14:</td><td>10.6x</td><td>→</td></tr> <tr><td>15:</td><td>10.1</td><td>↘</td></tr> <tr><td>16:</td><td>10.7x</td><td>↙</td></tr> <tr><td>17:</td><td>10.4x</td><td>↘</td></tr> <tr><td>18:</td><td>10.8x</td><td>→</td></tr> <tr><td>19:</td><td>10.9x</td><td>→</td></tr> <tr><td>20:</td><td>10.5x</td><td>↑</td></tr> <tr><td colspan="2">Serie</td><td>105.9</td></tr> <tr><td colspan="2">Total</td><td>210.8</td></tr> </table>	11:	10.8x	↙	12:	10.4x	↘	13:	10.7x	↘	14:	10.6x	→	15:	10.1	↘	16:	10.7x	↙	17:	10.4x	↘	18:	10.8x	→	19:	10.9x	→	20:	10.5x	↑	Serie		105.9	Total		210.8	<p>60 Skott</p> 	<table border="1" style="width:100%; border-collapse: collapse;"> <tr><td>21:</td><td>10.3x</td><td>↗</td></tr> <tr><td>22:</td><td>10.7x</td><td>↗</td></tr> <tr><td>23:</td><td>10.3x</td><td>↙</td></tr> <tr><td>24:</td><td>10.8x</td><td>↙</td></tr> <tr><td>25:</td><td>10.2x</td><td>↙</td></tr> <tr><td>26:</td><td>10.8x</td><td>↙</td></tr> <tr><td>27:</td><td>10.7x</td><td>↙</td></tr> <tr><td>28:</td><td>10.7x</td><td>↙</td></tr> <tr><td>29:</td><td>10.3x</td><td>↙</td></tr> <tr><td>30:</td><td>10.1</td><td>↓</td></tr> <tr><td colspan="2">Serie</td><td>104.9</td></tr> <tr><td colspan="2">Total</td><td>315.7</td></tr> </table>	21:	10.3x	↗	22:	10.7x	↗	23:	10.3x	↙	24:	10.8x	↙	25:	10.2x	↙	26:	10.8x	↙	27:	10.7x	↙	28:	10.7x	↙	29:	10.3x	↙	30:	10.1	↓	Serie		104.9	Total		315.7
11:	10.8x	↙																																																																									
12:	10.4x	↘																																																																									
13:	10.7x	↘																																																																									
14:	10.6x	→																																																																									
15:	10.1	↘																																																																									
16:	10.7x	↙																																																																									
17:	10.4x	↘																																																																									
18:	10.8x	→																																																																									
19:	10.9x	→																																																																									
20:	10.5x	↑																																																																									
Serie		105.9																																																																									
Total		210.8																																																																									
21:	10.3x	↗																																																																									
22:	10.7x	↗																																																																									
23:	10.3x	↙																																																																									
24:	10.8x	↙																																																																									
25:	10.2x	↙																																																																									
26:	10.8x	↙																																																																									
27:	10.7x	↙																																																																									
28:	10.7x	↙																																																																									
29:	10.3x	↙																																																																									
30:	10.1	↓																																																																									
Serie		104.9																																																																									
Total		315.7																																																																									
<p>60 Skott</p> 	<table border="1" style="width:100%; border-collapse: collapse;"> <tr><td>31:</td><td>10.5x</td><td>↗</td></tr> <tr><td>32:</td><td>10.6x</td><td>↗</td></tr> <tr><td>33:</td><td>10.3x</td><td>↗</td></tr> <tr><td>34:</td><td>10.6x</td><td>↗</td></tr> <tr><td>35:</td><td>10.9x</td><td>↘</td></tr> <tr><td>36:</td><td>10.6x</td><td>↘</td></tr> <tr><td>37:</td><td>9.5</td><td>↙</td></tr> <tr><td>38:</td><td>10.1</td><td>↘</td></tr> <tr><td>39:</td><td>10.8x</td><td>↙</td></tr> <tr><td>40:</td><td>10.6x</td><td>↘</td></tr> <tr><td colspan="2">Serie</td><td>104.5</td></tr> <tr><td colspan="2">Total</td><td>420.2</td></tr> </table>	31:	10.5x	↗	32:	10.6x	↗	33:	10.3x	↗	34:	10.6x	↗	35:	10.9x	↘	36:	10.6x	↘	37:	9.5	↙	38:	10.1	↘	39:	10.8x	↙	40:	10.6x	↘	Serie		104.5	Total		420.2																																						
31:	10.5x	↗																																																																									
32:	10.6x	↗																																																																									
33:	10.3x	↗																																																																									
34:	10.6x	↗																																																																									
35:	10.9x	↘																																																																									
36:	10.6x	↘																																																																									
37:	9.5	↙																																																																									
38:	10.1	↘																																																																									
39:	10.8x	↙																																																																									
40:	10.6x	↘																																																																									
Serie		104.5																																																																									
Total		420.2																																																																									

<p>Prov</p>	<p>1: 9.7 →</p> <p>2: 10.5x↑</p> <p>3: 10.2x↑</p> <p>4: 9.4 ↖</p> <p>5: 10.1 ↖</p> <p>6: 8.9 ↑</p> <p>7: 10.3x↑</p> <p>8: 10.4x↘</p> <p>9: 10.1 →</p> <p>10: 10.5x↑</p> <p>Serie 100.1</p> <p>Total 0.0</p>	<p>Prov</p>	<p>11: 10.4x↓</p> <p>12: 9.9 ↑</p> <p>13: 10.0 ↖</p> <p>14: 9.2 ↑</p> <p>15: 9.7 ↗</p> <p>16: 10.5x↗</p> <p>17: 10.8x←</p> <p>Serie 70.5</p> <p>Total 0.0</p>
<p>60 Skott</p>	<p>1: 10.2x↘</p> <p>2: 10.1 →</p> <p>3: 9.8 →</p> <p>4: 10.4x→</p> <p>5: 9.5 ↗</p> <p>6: 10.5x↑</p> <p>7: 9.9 →</p> <p>8: 10.1 ↑</p> <p>9: 10.5x↓</p> <p>10: 10.0 ↑</p> <p>Serie 101.0</p> <p>Total 101.0</p>	<p>60 Skott</p>	<p>11: 10.3x↘</p> <p>12: 10.8x↑</p> <p>13: 10.1 ↑</p> <p>14: 10.8x↓</p> <p>15: 10.7x↓</p> <p>16: 10.4x↓</p> <p>17: 10.5x↑</p> <p>18: 10.4x↑</p> <p>19: 10.0 ↑</p> <p>20: 10.0 ↖</p> <p>Serie 104.0</p> <p>Total 205.0</p>
<p>60 Skott</p>	<p>21: 10.4x↑</p> <p>22: 10.7x←</p> <p>23: 9.9 →</p> <p>24: 10.1 ↑</p> <p>25: 10.7x↓</p> <p>26: 10.3x↑</p> <p>27: 9.9 →</p> <p>28: 10.4x↑</p> <p>29: 9.9 →</p> <p>30: 10.6x←</p> <p>Serie 102.9</p> <p>Total 307.9</p>	<p>60 Skott</p>	<p>31: 9.6 →</p> <p>32: 9.5 →</p> <p>33: 10.2x↑</p> <p>34: 10.2x←</p> <p>35: 9.6 ←</p> <p>36: 10.7x↘</p> <p>37: 10.2x↓</p> <p>38: 10.2x↑</p> <p>39: 10.2x↘</p> <p>40: 9.3 ↖</p> <p>Serie 99.7</p> <p>Total 407.6</p>

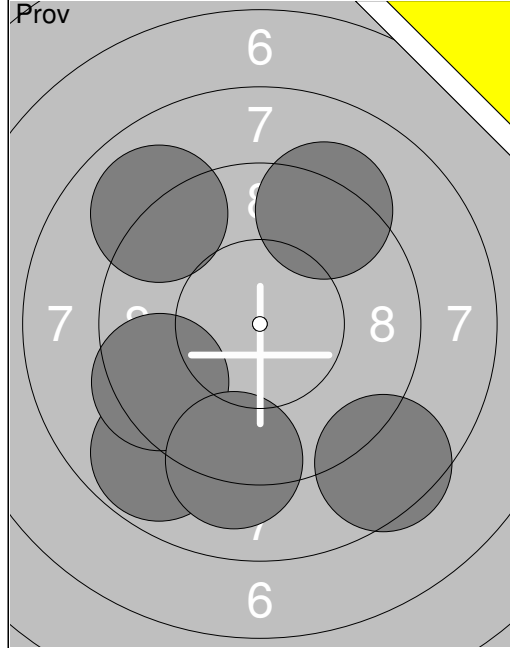

1:	8.8	↙
2:	8.5	↘
3:	9.3	↗
4:	9.0	↖
5:	9.4	↙
6:	9.1	↘
Serie		54.1
Total		0.0

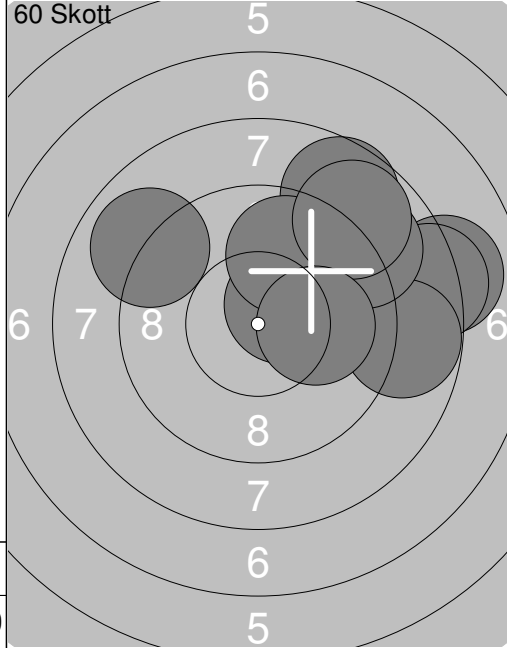

1:	9.0	↖
2:	10.5x	↗
3:	8.1	→
4:	8.3	→
5:	8.8	→
6:	8.7	↗
7:	9.0	↗
8:	9.8	↗
9:	8.8	↗
10:	10.1	→
Serie		91.1
Total		91.1

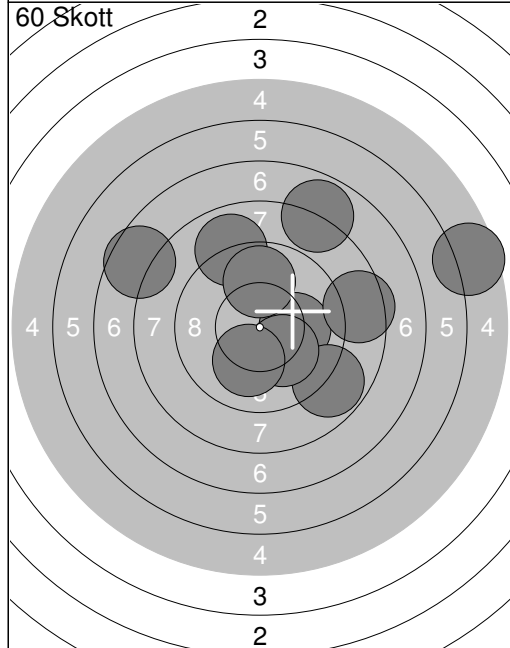

11:	7.6	↖
12:	8.9	↗
13:	10.1	→
14:	8.8	↘
15:	10.1	↘
16:	5.5	→
17:	9.8	↗
18:	10.1	↘
19:	7.9	↗
20:	8.5	→
Serie		87.3
Total		178.4

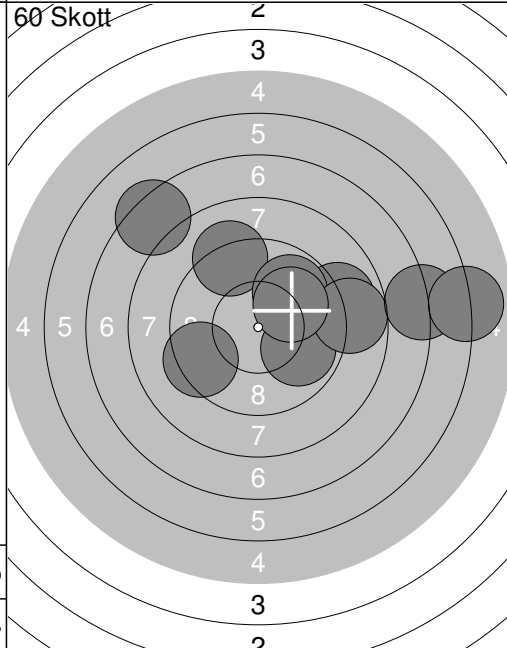

21:	9.2	↖
22:	8.9	→
23:	9.4	↙
24:	9.9	↘
25:	9.8	↗
26:	7.3	↖
27:	8.7	→
28:	7.0	→
29:	10.0	↗
30:	6.0	→
Serie		86.2
Total		264.6

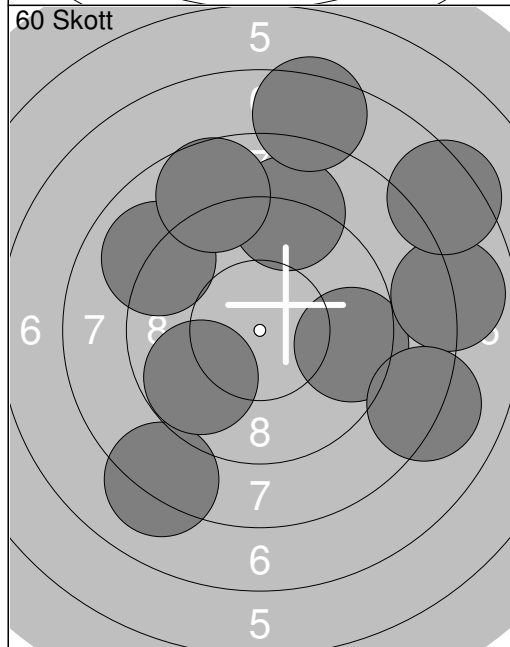

31:	9.5	→
32:	8.1	↘
33:	9.8	↙
34:	7.9	→
35:	8.1	↘
36:	9.1	↗
37:	7.4	↗
38:	7.5	↗
39:	9.0	↖
40:	8.7	↗
Serie		85.1
Total		349.7

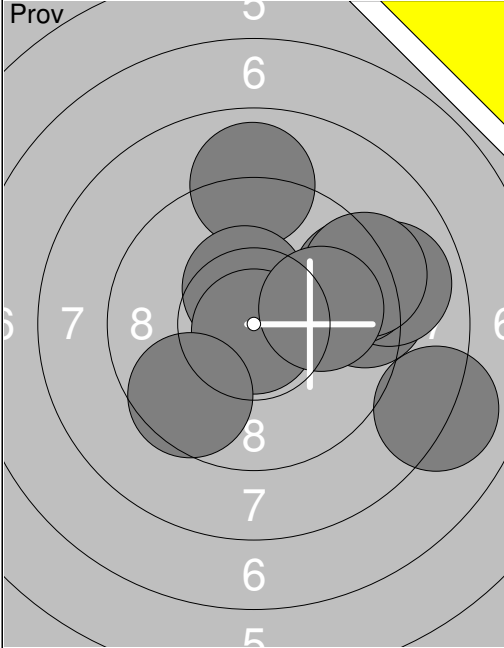
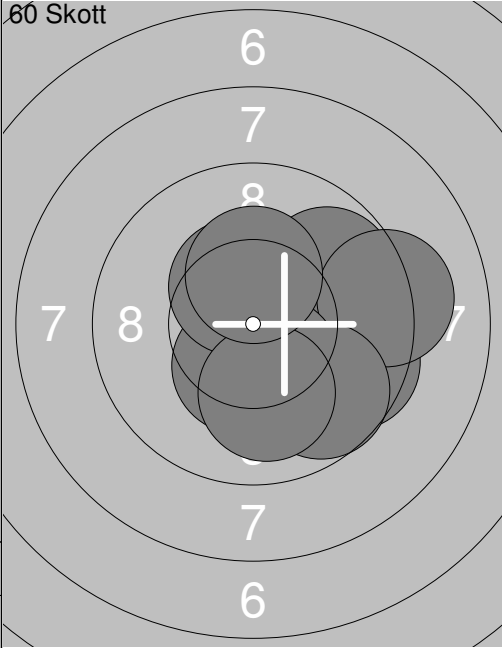
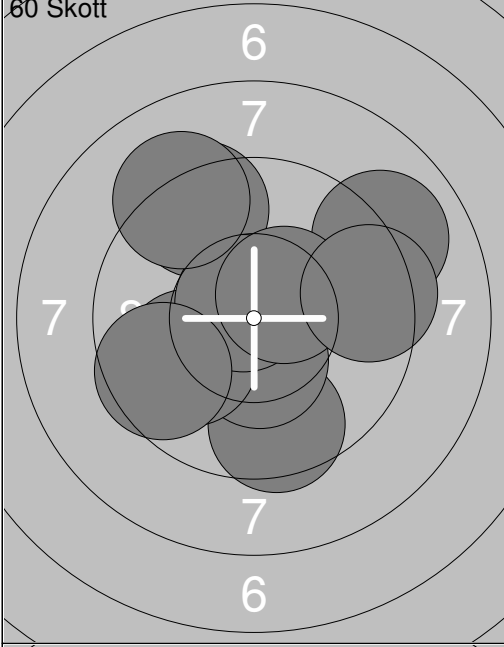
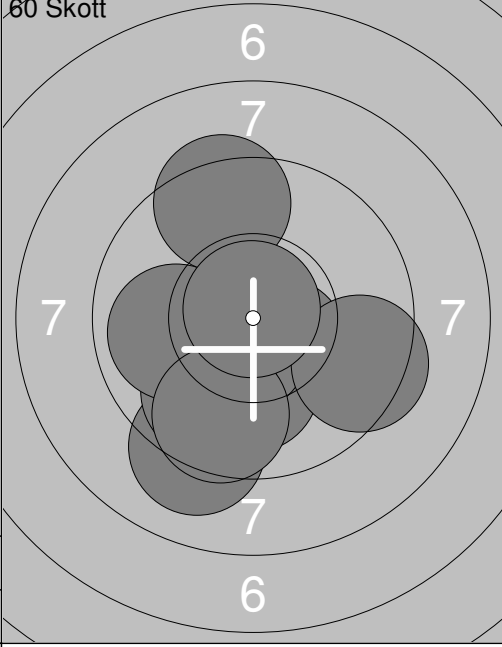
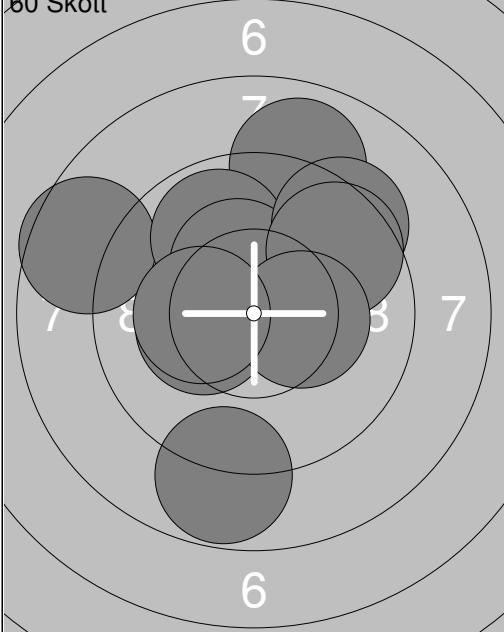
Skjutlag	Tavla	Adam Tiburzi	
2	30		
S	Drängsmarks Skf		
08.04.2017	UMEKULAN 2017	Umeå skytteallians	
Prov		1: 8.1 → 2: 9.3 → 3: 8.9 ↑ 4: 8.9 → 5: 9.4 → 6: 9.2 → 7: 10.4x↑ 8: 10.8x↓ 9: 9.6 ↓ 10: 10.0 → Serie 94.6 Total 0.0	60 Skott  1: 9.6 → 2: 9.8 ↗ 3: 10.7x↘ 4: 9.2 → 5: 10.4x↓ 6: 10.4x↓ 7: 10.4x↑ 8: 9.7 ↘ 9: 10.0 ↓ 10: 10.3x↑ Serie 100.5 Total 100.5
60 Skott		11: 9.5 ↓ 12: 10.4x↓ 13: 9.4 ↖ 14: 10.0 ↙ 15: 10.7x↖ 16: 9.0 ↗ 17: 9.1 ↖ 18: 10.4x↗ 19: 9.6 ↙ 20: 9.4 → Serie 97.5 Total 198.0	60 Skott  21: 10.5x↘ 22: 10.1 ↓ 23: 9.1 ↓ 24: 10.6x↘ 25: 9.4 → 26: 9.8 ↓ 27: 9.9 ← 28: 9.4 ↑ 29: 9.6 ↓ 30: 10.8x↑ Serie 99.2 Total 297.2
60 Skott		31: 8.6 ↙ 32: 9.0 ↑ 33: 8.8 ↓ 34: 9.9 ↖ 35: 10.3x↖ 36: 9.3 ↗ 37: 9.6 ↗ 38: 10.3x↙ 39: 10.3x→ 40: 10.3x← Serie 96.4 Total 393.6	

<p>Prov</p>	<p>Prov</p>	
Serie 93.8	Serie 10.1	
Total 0.0	Total 0.0	
<p>60 Skott</p>	<p>60 Skott</p>	
Serie 103.8	Serie 101.6	
Total 103.8	Total 205.4	
<p>60 Skott</p>	<p>60 Skott</p>	
Serie 103.2	Serie 103.0	
Total 308.6	Total 411.6	

<p>Prov</p>	<p>1: 9.9 ↘ 2: 9.6 ← 3: 10.6x↘ 4: 8.4 ← 5: 9.7 ↙ 6: 9.2 ↗ 7: 9.4 ↙ 8: 10.0 ↖ 9: 9.8 ↘ 10: 10.3x↗</p> <p>Serie 96.9 Total 0.0</p>	<p>Prov</p>	<p>11: 9.7 ↘ 12: 7.8 → 14: 7.4 → 15: 9.4 ↗ 16: 9.0 ↑</p> <p>Serie 43.3 Total 0.0</p>
<p>60 Skott</p>	<p>1: 9.4 ↗ 2: 8.2 → 3: 9.0 ↗ 4: 9.4 ↗ 5: 10.2x↘ 6: 8.8 ↗ 7: 7.9 ↗ 8: 8.8 ← 9: 10.0 ↗ 10: 9.5 ↗</p> <p>Serie 91.2 Total 91.2</p>	<p>60 Skott</p>	<p>11: 10.0 ↙ 12: 9.4 ← 13: 9.0 ↘ 14: 10.5x↗ 15: 10.0 ↗ 16: 9.2 ↙ 17: 8.2 ↗ 18: 8.9 ↖ 19: 10.7x↘ 20: 9.4 ↘</p> <p>Serie 95.3 Total 186.5</p>
<p>60 Skott</p>	<p>21: 8.5 ↗ 22: 10.6x↘ 23: 9.2 ↘ 24: 10.2x↘ 25: 9.6 ↗ 26: 10.3x↗ 27: 10.1 ↙ 28: 8.0 ↖ 29: 9.4 ↗ 30: 10.6x↗</p> <p>Serie 96.5 Total 283.0</p>	<p>60 Skott</p>	<p>31: 8.5 ↗ 32: 10.6x↗ 33: 9.0 ↗ 34: 9.2 ↗ 35: 9.6 ← 36: 9.6 → 37: 9.2 ↖ 38: 10.4x↘ 39: 9.5 ↙ 40: 8.3 ↗</p> <p>Serie 93.9 Total 376.9</p>

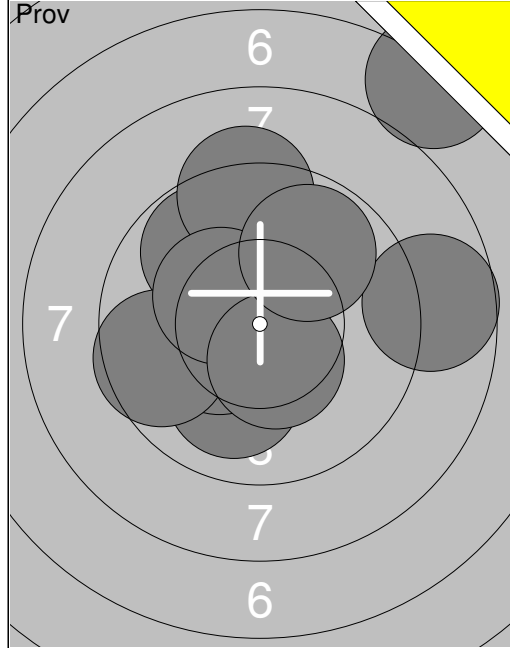

1:	10.0	↘
2:	10.4	✗
3:	9.8	↖
4:	7.0	↗
5:	9.3	↑
6:	9.6	←
7:	8.7	→
8:	10.3	✗
9:	10.4	↘
10:	9.8	↗
Serie		95.3
Total		0.0

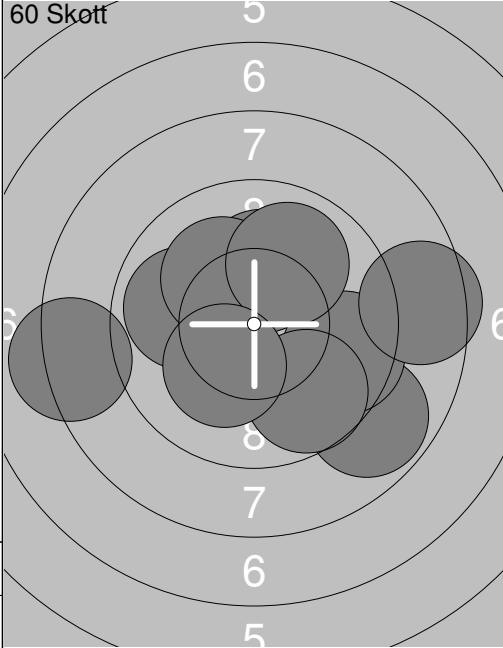

1:	8.2	←
2:	10.2	↗
3:	9.9	←
4:	8.8	↘
5:	9.6	→
6:	10.1	↗
7:	8.5	→
8:	10.0	↗
9:	9.7	↘
10:	10.2	✗
Serie		95.2
Total		95.2

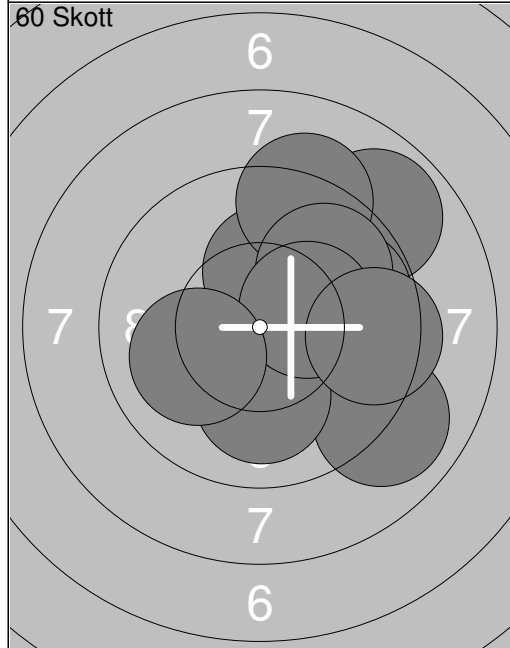

11:	8.9	↗
12:	9.8	→
13:	9.0	↘
14:	10.2	↗
15:	10.1	↓
16:	9.2	↗
17:	9.8	↗
18:	10.3	✗→
19:	9.5	→
20:	10.1	←
Serie		96.9
Total		192.1

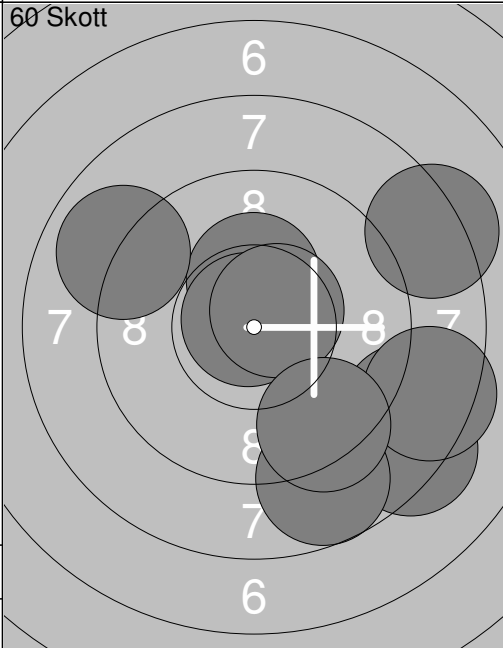

21:	10.3	↗
22:	8.9	↖
23:	8.6	↘
24:	8.3	↘
25:	8.2	↗
26:	8.7	↘
27:	10.8	✗
28:	8.4	→
29:	10.6	✗↗
30:	9.4	↘
Serie		92.2
Total		284.3

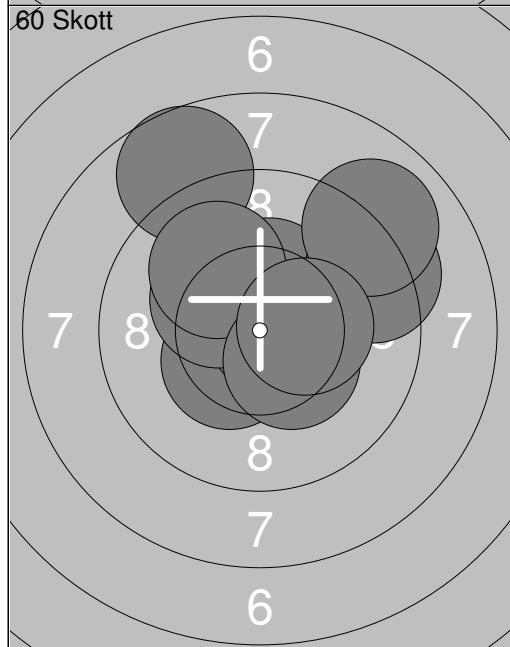

31:	10.4	↗
32:	10.4	✗
33:	9.3	↗
34:	8.7	↖
35:	10.8	✗→
36:	10.3	✗
37:	9.0	↗
38:	10.0	↖
39:	10.4	✗↘
40:	10.4	✗→
Serie		99.7
Total		384.0

<p>Prov</p>	<p>1: 10.3x↘ 2: 9.6 ↓ 3: 10.8x➤ 4: 9.9 ↙ 5: 10.4x↘ 6: 10.3x↓ 7: 9.6 ↓ 8: 10.0 ↙ 9: 10.6x↑ 10: 10.2x➤</p> <p>Serie 101.7 Total 0.0</p>	<p>Prov</p>	<p>11: 10.3x➤ 12: 10.5x↑ 13: 10.6x↘</p> <p>Serie 31.4 Total 0.0</p>
-------------	---	-------------	---

<p>60 Skott</p>	<p>1: 10.1 ↗ 2: 10.5x↘ 3: 9.7 ➤ 4: 10.3x↓ 5: 10.7x↘ 6: 10.6x↘ 7: 10.8x↘ 8: 10.1 ↓ 9: 10.1 ➤ 10: 10.2x↓</p> <p>Serie 103.1 Total 103.1</p>	<p>60 Skott</p>	<p>11: 9.4 ↘ 12: 10.6x↗ 13: 10.6x↑ 14: 10.1 ↑ 15: 10.4x↘ 16: 9.9 ↙ 17: 10.4x➤ 18: 8.4 ↗ 19: 10.7x↘ 20: 10.2x↘</p> <p>Serie 100.7 Total 203.8</p>
-----------------	---	-----------------	--

<p>60 Skott</p>	<p>21: 10.8x↓ 22: 10.2x↘ 23: 9.8 ← 24: 9.9 ↙ 25: 10.8x➤ 26: 10.2x↘ 27: 10.5x↓ 28: 10.1 ↗ 29: 10.3x↘ 30: 10.2x➤</p> <p>Serie 102.8 Total 306.6</p>	<p>60 Skott</p>	<p>31: 10.0 ➤ 32: 10.3x↘ 33: 10.2x↘ 34: 10.2x➤ 35: 10.5x↘ 36: 9.4 ← 37: 10.3x↘ 38: 10.1 ↙ 39: 10.3x➤ 40: 10.5x↑</p> <p>Serie 101.8 Total 408.4</p>
-----------------	---	-----------------	--

<p>Prov</p>	<p>1: 10.8x↘</p> <p>2: 9.9 ↑</p> <p>3: 9.8 ↖</p> <p>4: 9.5 ←</p> <p>5: 10.1 →</p> <p>6: 9.7 ↑</p> <p>7: 10.2x→</p> <p>8: 9.8 ↗</p> <p>9: 9.8 ↗</p> <p>10: 10.7x→</p> <p>Serie 100.3</p> <p>Total 0.0</p>	<p>Prov</p>	<p>11: 10.5x↘</p> <p>12: 10.2x↗</p> <p>13: 10.5x↖</p> <p>14: 10.6x↘</p> <p>15: 10.2x→</p> <p>16: 10.1 ↘</p> <p>Serie 62.1</p> <p>Total 0.0</p>
-------------	--	-------------	--

<p>60 Skott</p>	<p>1: 9.7 →</p> <p>2: 9.1 ↑</p> <p>3: 10.3x↘</p> <p>4: 10.1 →</p> <p>5: 9.5 →</p> <p>6: 9.5 →</p> <p>7: 10.5x→</p> <p>8: 10.3x↗</p> <p>9: 10.5x↗</p> <p>10: 10.2x↘</p> <p>Serie 99.7</p> <p>Total 99.7</p>	<p>60 Skott</p>	<p>11: 9.9 ↑</p> <p>12: 9.0 →</p> <p>13: 9.5 →</p> <p>14: 9.2 ↘</p> <p>15: 10.2x↘</p> <p>16: 9.4 →</p> <p>17: 10.0 →</p> <p>18: 10.8x↖</p> <p>19: 10.5x↖</p> <p>20: 10.3x↗</p> <p>Serie 98.8</p> <p>Total 198.5</p>
-----------------	--	-----------------	---

<p>60 Skott</p>	<p>21: 8.5 →</p> <p>22: 10.3x→</p> <p>23: 9.8 ↗</p> <p>24: 9.7 ↘</p> <p>25: 10.6x→</p> <p>26: 10.4x↗</p> <p>27: 9.4 ↗</p> <p>28: 9.3 →</p> <p>29: 10.0 ↗</p> <p>30: 10.0 →</p> <p>Serie 98.0</p> <p>Total 296.5</p>	<p>60 Skott</p>	<p>31: 9.5 ↗</p> <p>32: 9.0 →</p> <p>33: 9.6 ↑</p> <p>34: 10.2x→</p> <p>35: 9.8 ↗</p> <p>36: 10.2x↗</p> <p>37: 10.0 ↗</p> <p>38: 9.7 ↑</p> <p>39: 8.9 →</p> <p>40: 9.7 ↗</p> <p>Serie 96.6</p> <p>Total 393.1</p>
-----------------	---	-----------------	---

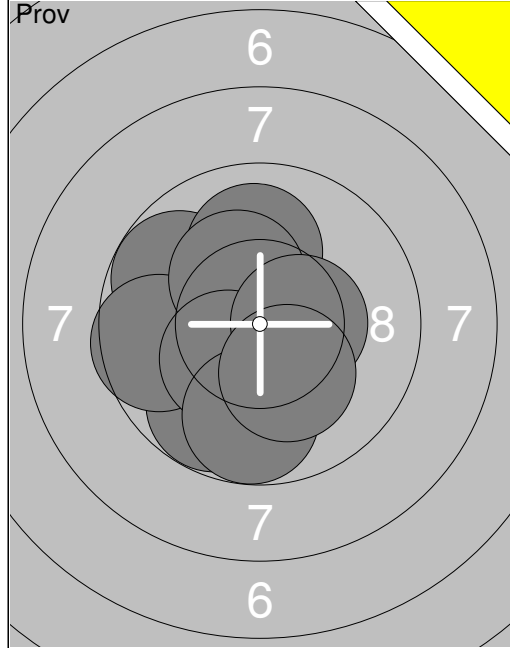

1:	10.2x↘
2:	9.8 ↓
3:	9.8 ↖
4:	9.6 ←
5:	10.0 ↑
6:	10.3x↗
7:	10.3x↘
8:	10.4x→
9:	9.7 ↓
10:	10.2x↘
Serie	100.3
Total	0.0

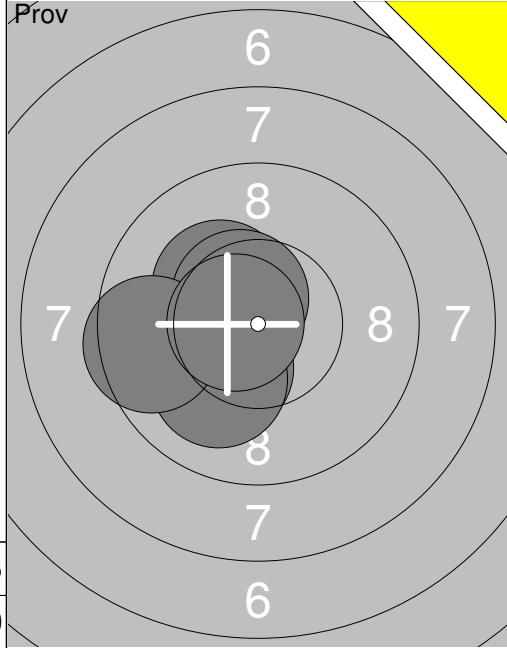

11:	10.2x↘
12:	10.3x↘
13:	10.1 ↓
14:	10.3x↗
15:	10.5x↗
16:	9.5 ←
17:	10.6x↖
Serie	71.5
Total	0.0

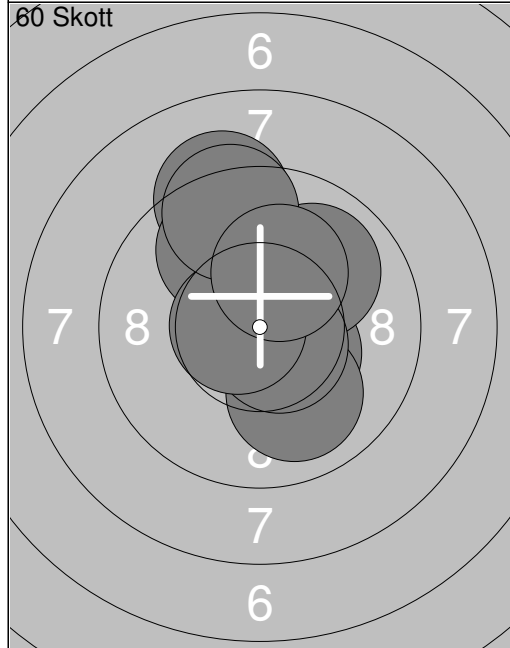

1:	10.8x↘
2:	9.2 ↑
3:	10.4x↘
4:	10.0 ↓
5:	10.0 ↗
6:	10.6x↘
7:	9.8 ↖
8:	10.7x↖
9:	9.4 ↑
10:	10.2x↗
Serie	101.1
Total	101.1

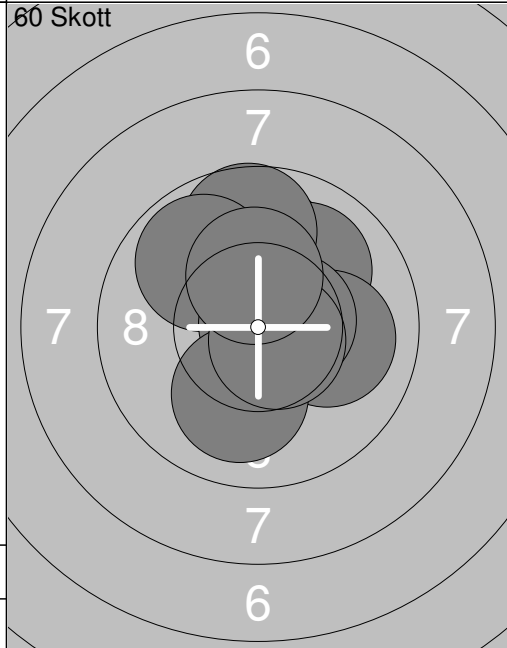

11:	10.0 ↑
12:	10.0 ↗
13:	9.7 ↑
14:	9.9 ↖
15:	10.8x→
16:	10.0 →
17:	10.6x→
18:	10.0 ↓
19:	10.6x↘
20:	10.3x↗
Serie	101.9
Total	203.0

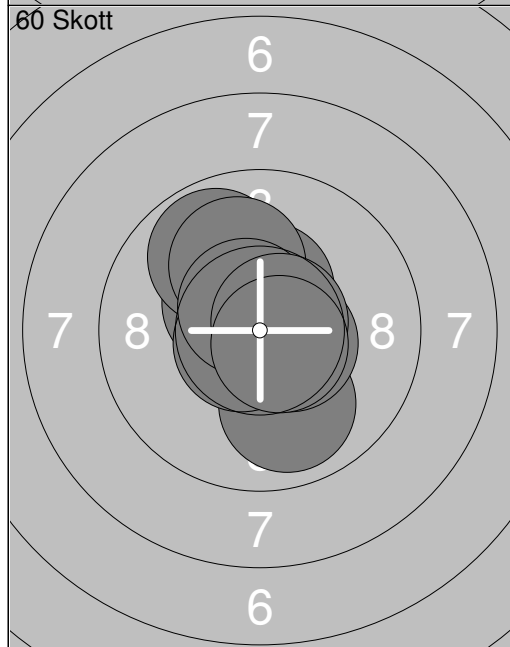

21:	10.4x↘
22:	9.9 ↓
23:	10.7x↘
24:	10.5x→
25:	9.8 ↖
26:	10.4x↗
27:	10.1 ↑
28:	10.6x↗
29:	10.7x→
30:	10.6x↘
Serie	103.7
Total	306.7

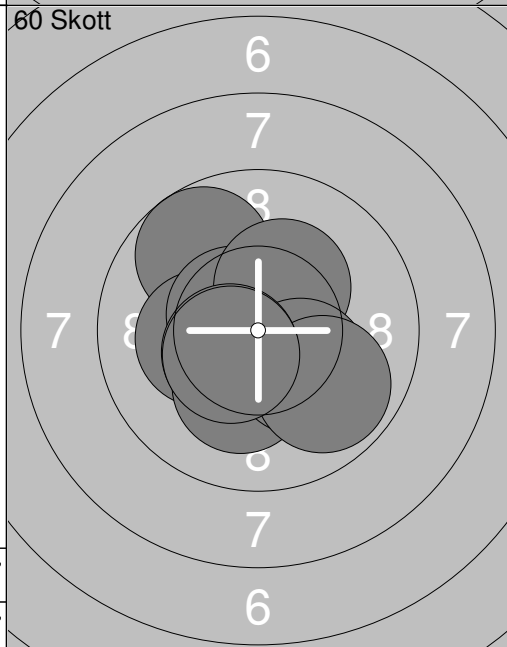

31:	9.7 ↖
32:	10.2x↖
33:	10.2x↘
34:	10.8x↘
35:	10.6x↖
36:	10.3x↗
37:	10.2x↘
38:	9.9 ↓
39:	10.5x↘
40:	10.5x↘
Serie	102.9
Total	409.6

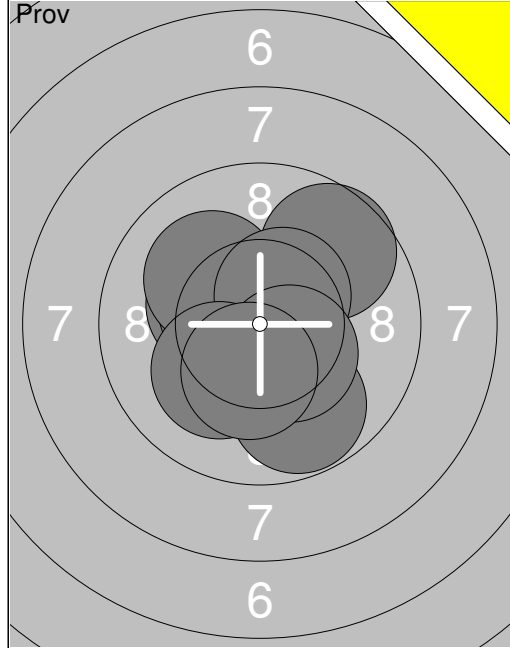

1:	9.7 ↗
2:	10.3 ↘
3:	10.5 ↘
4:	10.8 ↘
5:	10.1 ↖
6:	10.5 ↗
7:	9.8 ↓
8:	10.4 ↘
9:	10.2 ↘
10:	10.3 ↘
Serie 102.6	
Total 0.0	

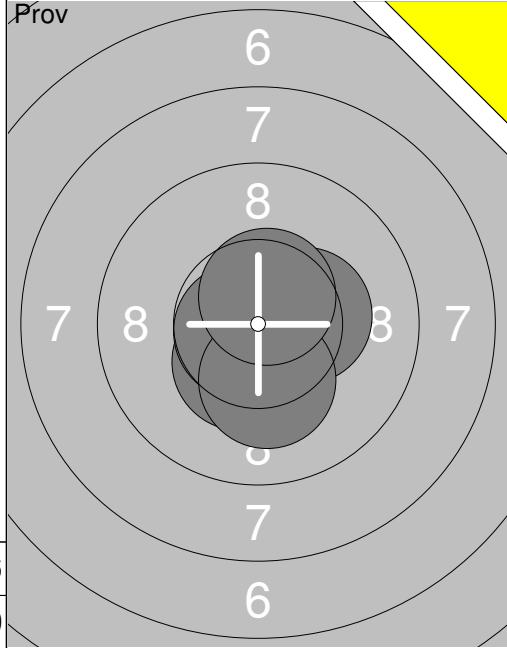

11:	10.3x →
12:	10.4x ↓
13:	10.7x ↘
14:	10.2x ↓
15:	10.6x ↗
Serie 52.2	
Total 0.0	

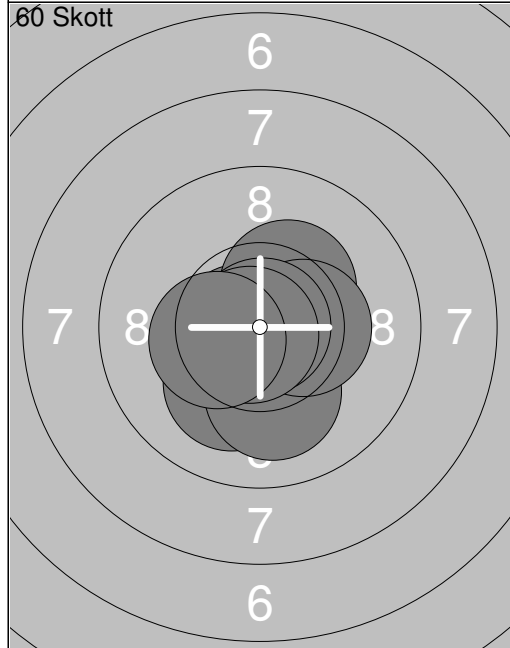

1:	10.1 ↓
2:	10.7x ↓
3:	10.7x ↘
4:	10.7x ↓
5:	10.1 ↓
6:	10.3x ↗
7:	10.4x →
8:	10.9x →
9:	10.8x ↘
10:	10.4x ↘
Serie 105.1	
Total 105.1	

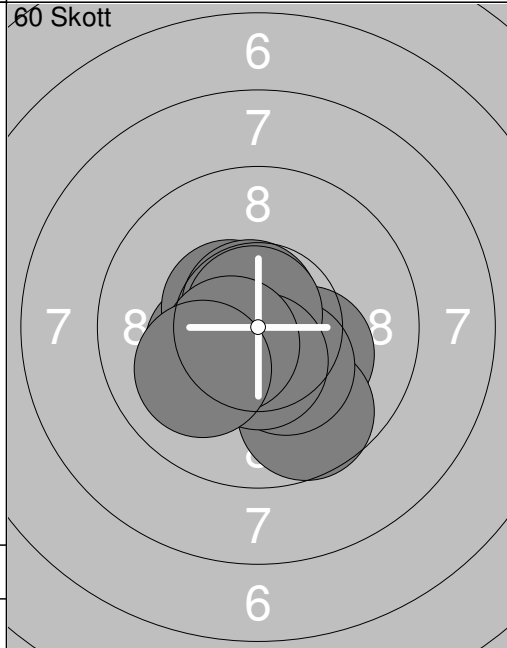

11:	10.3x ↘
12:	10.5x ↘
13:	10.2x ↘
14:	10.7x ↗
15:	9.7 ↓
16:	10.3x ↓
17:	10.8x ↗
18:	10.5x ↓
19:	10.5x ↘
20:	10.0 ↙
Serie 103.5	
Total 208.6	

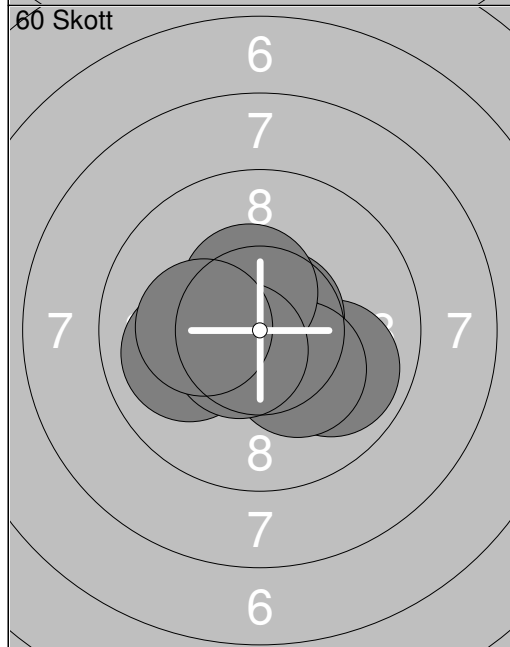

21:	10.8x ↓
22:	9.9 →
23:	10.8x →
24:	10.7x ↗
25:	10.6x ↓
26:	10.2x ↓
27:	10.4x ↗
28:	10.0 ←
29:	10.6x ↘
30:	10.2x ↘
Serie 104.2	
Total 312.8	

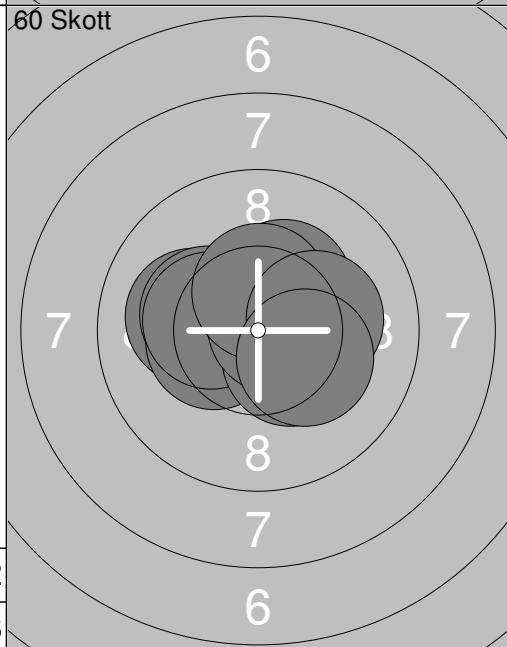

31:	10.1 ←
32:	10.3x ↘
33:	10.4x ↘
34:	10.3x ↘
35:	10.3x ↗
36:	10.4x ↓
37:	10.7x →
38:	10.4x ↗
39:	10.2x →
40:	10.2x ↓
Serie 103.3	
Total 416.1	

Skjutlag 2	Tavla 40	Jan-Olov Jonsson	
S		Umeå Skf	
08.04.2017		UMEKULAN 2017	Umeå skytteallians
Pröv 	1: 9.5 ↗ 2: 7.7 → 3: 8.9 ↗ 4: 8.4 ↓ 5: 8.7 ↓ 6: 9.2 ↓ 7: 9.0 ↓ 8: 10.2x ↗ 9: 9.7 ↓ 10: 10.2x ↑ Serie 91.5 Total 0.0	Pröv 	11: 9.9 → 12: 10.6x ↗ 13: 9.3 ↑ 14: 9.2 ↑ 15: 9.1 ↑ 16: 7.9 ↗ 17: 9.5 ↓ 18: 9.9 ↓ 19: 9.8 → 20: 9.1 → Serie 94.3 Total 0.0
Pröv 	21: 10.5x ↑ 22: 10.2x ↗ Serie 20.7 Total 0.0	60 Skott 	1: 9.1 ↓ 2: 9.2 ↑ 3: 9.6 ↓ 4: 10.2x ← 5: 9.9 ↗ 6: 8.6 ↗ 7: 9.6 ↑ 8: 10.4x ↑ 9: 9.9 ↗ 10: 9.9 ↗ Serie 96.4 Total 96.4
60 Skott 	11: 9.2 ↗ 12: 9.6 ↓ 13: 9.3 ↓ 14: 9.2 ↓ 15: 9.8 ↑ 16: 9.8 ↑ 17: 10.3x ← 18: 9.8 ↗ 19: 9.9 ↗ 20: 9.6 ↗ Serie 96.5 Total 192.9	60 Skott 	21: 9.8 ↓ 22: 9.5 ← 23: 10.1 ↓ 24: 10.9x → 25: 10.6x ← 26: 10.6x ↓ 27: 9.9 → 28: 10.5x ↗ 29: 10.8x ↗ 30: 10.2x ← Serie 102.9 Total 295.8
60 Skott 	31: 9.3 ↗ 32: 9.8 ↑ 33: 10.4x → 34: 10.2x ← 35: 10.6x ← 36: 10.9x ↗ 37: 9.7 → 38: 10.7x ↗ 39: 10.3x ↗ 40: 10.9x ↓ Serie 102.8 Total 398.6		

<p>Prov</p>	<p>1: 0.0 →</p> <p>2: 2.5 ↗</p> <p>3: 9.2 ↑</p> <p>4: 7.2 ↖</p> <p>5: 5.6 →</p> <p>6: 10.4x ↘</p> <p>7: 7.9 ↗</p> <p>8: 6.8 ↖</p> <p>9: 8.0 ↙</p> <p>10: 9.6 →</p> <p>Serie 67.2</p> <p>Total 0.0</p>	<p>Prov</p> <p>11: 10.0 ↗</p> <p>Serie 10.0</p> <p>Total 0.0</p>
-------------	---	--

<p>60 Skott</p>	<p>1: 2.6 ←</p> <p>2: 2.5 →</p> <p>3: 3.4 →</p> <p>4: 9.1 →</p> <p>5: 10.1 ↓</p> <p>6: 3.7 ↓</p> <p>7: 5.2 ↑</p> <p>8: 5.1 ↓</p> <p>9: 7.0 ←</p> <p>10: 10.2x ↘</p> <p>Serie 58.9</p> <p>Total 58.9</p>	<p>60 Skott</p> <p>11: 9.4 ↖</p> <p>12: 7.0 →</p> <p>13: 6.0 ←</p> <p>14: 6.7 ↖</p> <p>15: 7.9 ↑</p> <p>16: 6.5 ↘</p> <p>17: 9.5 ↓</p> <p>18: 5.1 ↑</p> <p>19: 5.5 →</p> <p>20: 6.6 ↑</p> <p>Serie 70.2</p> <p>Total 129.1</p>
-----------------	---	--

<p>60 Skott</p>	<p>21: 8.4 ↗</p> <p>22: 7.8 ↓</p> <p>23: 9.1 ↖</p> <p>24: 9.2 →</p> <p>25: 8.6 →</p> <p>26: 9.9 ↑</p> <p>27: 7.6 →</p> <p>28: 9.5 ↑</p> <p>29: 10.7x →</p> <p>30: 10.1 ↑</p> <p>Serie 90.9</p> <p>Total 220.0</p>	<p>60 Skott</p> <p>31: 8.5 ↗</p> <p>32: 9.9 ↗</p> <p>33: 9.8 ↑</p> <p>34: 7.7 →</p> <p>35: 7.1 ↖</p> <p>36: 5.7 →</p> <p>37: 8.0 ↙</p> <p>38: 8.2 →</p> <p>39: 2.5 ←</p> <p>40: 6.8 ↖</p> <p>Serie 74.2</p> <p>Total 294.2</p>
-----------------	---	--

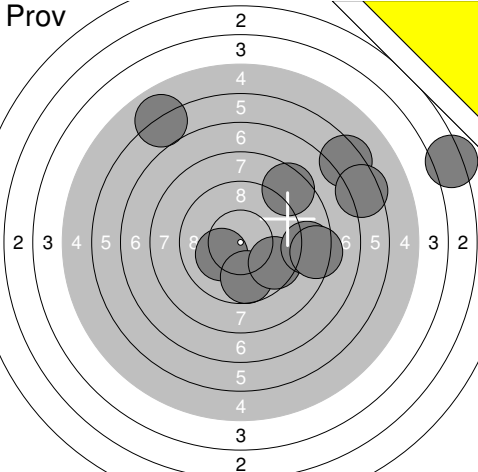
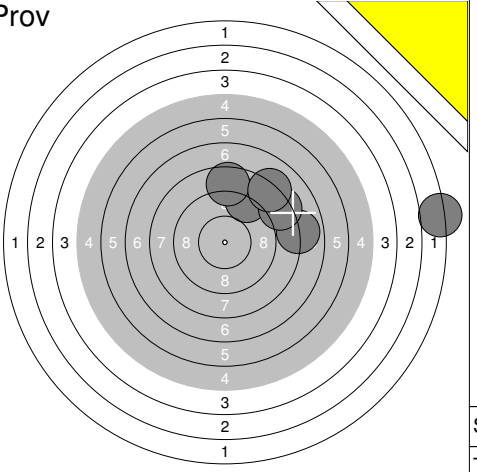
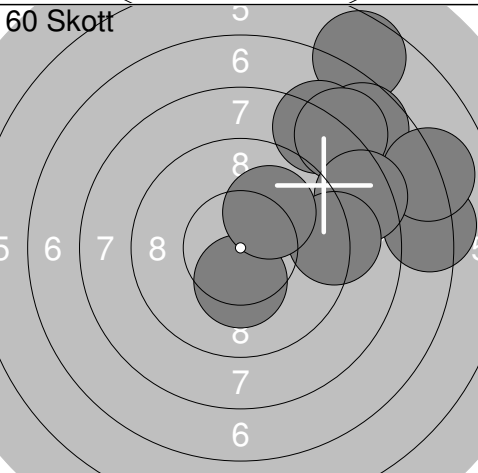
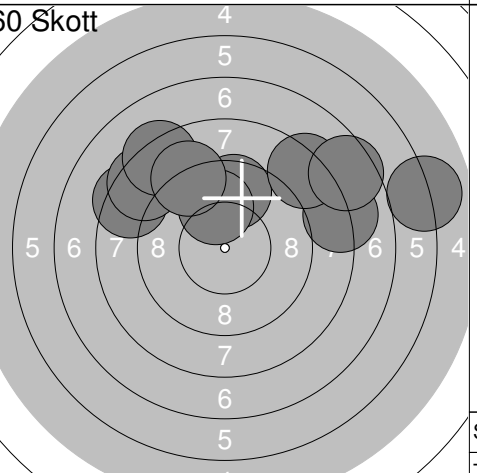
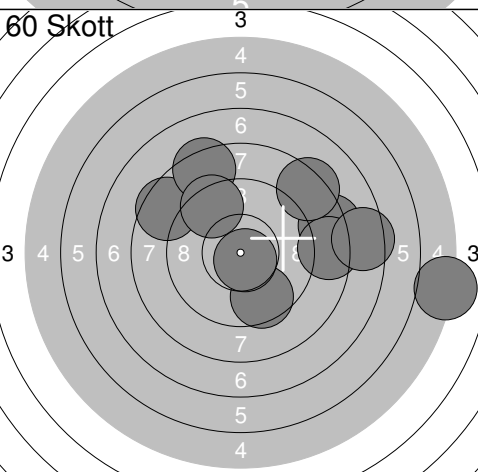
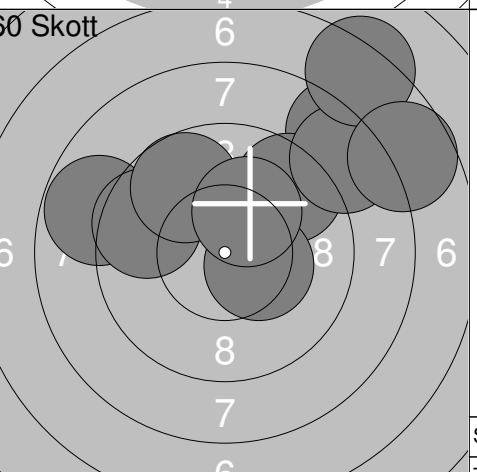
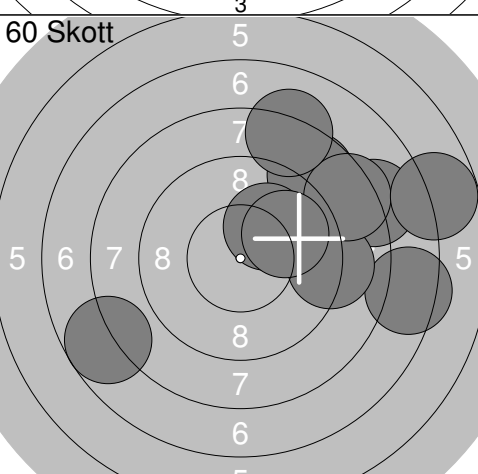
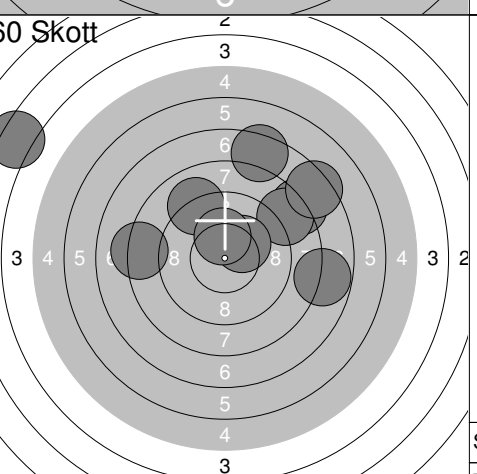
Skjutlag 3	Tavla 3	Anton Lind	
S		Skoga-Ekshärad Skf	
08.04.2017		UMEKULAN 2017	
Prov		Umeå skytteallians	
	1: 10.2x ↙ 2: 9.7 ↓ 3: 9.6 ↘ 4: 3.2 → 5: 6.4 ↗ 6: 6.4 ↗ 7: 8.7 → 8: 8.5 ↗ 9: 6.0 ↗ 10: 8.3 → Serie 77.0 Total 0.0		11: 9.0 ↗ 13: 7.9 → 14: 2.0 → 15: 8.6 ↑ 16: 8.3 ↗ 17: 8.1 ↗ Serie 43.9 Total 0.0
	1: 7.3 → 2: 6.6 ↗ 3: 7.7 ↗ 4: 8.2 ↗ 5: 10.3x ↓ 6: 8.0 ↗ 7: 7.1 → 8: 8.4 → 9: 9.1 → 10: 10.1 ↗ Serie 82.8 Total 82.8		11: 9.6 ↑ 12: 8.4 ↖ 13: 8.5 ↖ 14: 8.1 → 15: 6.0 → 16: 8.3 ↗ 17: 8.3 ↗ 18: 9.9 ↑ 19: 9.1 ↗ 20: 7.6 ↗ Serie 83.8 Total 166.6
	21: 8.3 → 22: 8.5 ↗ 23: 8.4 ↗ 24: 5.0 → 25: 9.6 ↓ 26: 8.4 → 27: 9.4 ↗ 28: 7.5 → 29: 8.3 ↗ 30: 10.7x ↓ Serie 84.1 Total 250.7		31: 8.8 ↖ 32: 9.6 ↖ 33: 9.7 ↗ 34: 8.2 ↗ 35: 9.5 ↗ 36: 8.5 ↗ 37: 10.4x → 38: 10.2x ↑ 39: 7.3 ↗ 40: 7.7 → Serie 89.9 Total 340.6
	41: 7.7 ↖ 42: 8.7 ↗ 43: 7.4 → 44: 8.0 → 45: 10.1 ↗ 46: 9.1 → 47: 8.4 ↗ 48: 6.8 → 49: 9.9 ↗ 50: 8.2 ↑ Serie 84.3 Total 424.9		51: 8.1 ↗ 52: 3.3 ↖ 53: 8.2 ↖ 54: 8.6 ↗ 55: 9.1 ↗ 56: 10.2x ↗ 57: 7.4 ↗ 58: 7.4 ↑ 59: 7.8 → 60: 10.3x ↑ Serie 80.4 Total 505.3

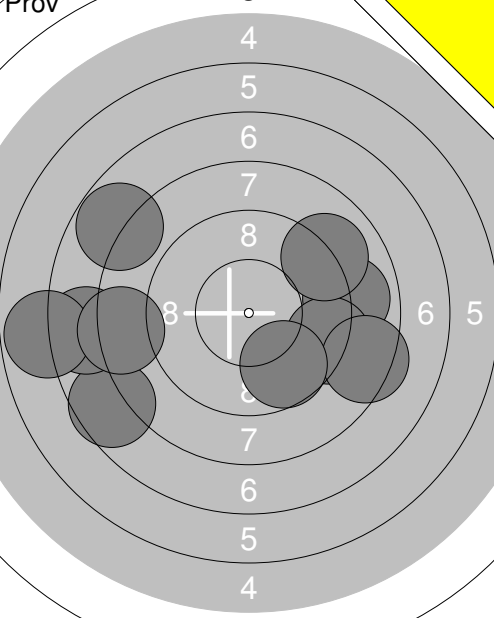
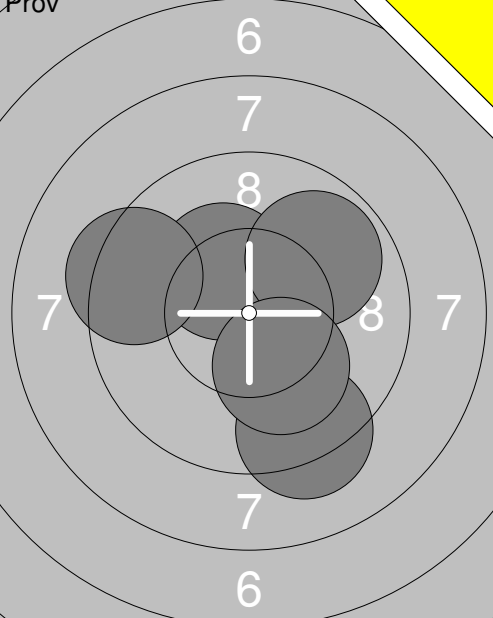
<p>Prov</p> 	<p>1: 8.9 →</p> <p>2: 7.6 ↙</p> <p>3: 9.2 →</p> <p>4: 8.4 →</p> <p>5: 9.0 ↗</p> <p>6: 7.6 ←</p> <p>7: 7.8 ↖</p> <p>8: 9.7 ↓</p> <p>9: 6.8 ←</p> <p>10: 8.3 ←</p>	<p>Prov</p> 	<p>11: 10.3x ↘</p> <p>12: 9.3 ↓</p> <p>13: 9.9 ↗</p> <p>14: 9.4 ←</p> <p>15: 10.1 ↓</p>
Serie	83.3	Serie	49.0
Total	0.0	Total	0.0

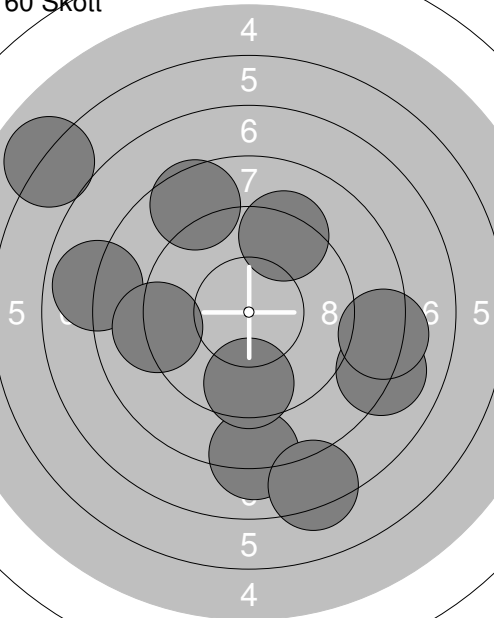
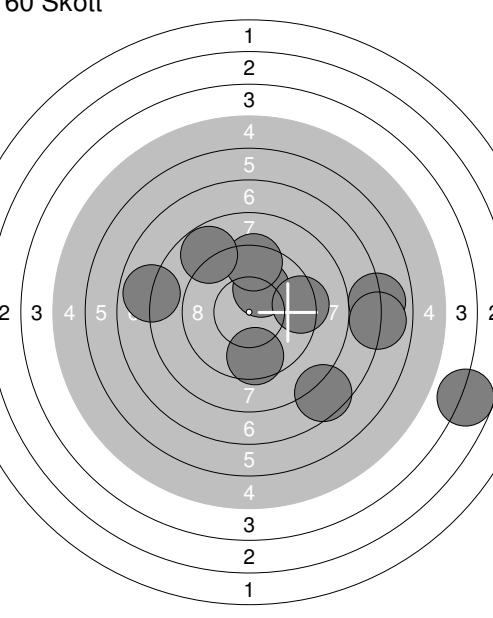
<p>60 Skott</p> 	<p>1: 8.6 ↗</p> <p>2: 6.0 ↖</p> <p>3: 8.1 ↓</p> <p>4: 9.5 ↓</p> <p>5: 7.3 ↓</p> <p>6: 9.3 ↗</p> <p>7: 8.1 →</p> <p>8: 7.9 ←</p> <p>9: 8.2 →</p> <p>10: 9.1 ←</p>	<p>60 Skott</p> 	<p>11: 10.1 ↗</p> <p>12: 3.7 →</p> <p>13: 9.6 ↓</p> <p>14: 9.4 ↑</p> <p>15: 9.3 →</p> <p>16: 7.0 →</p> <p>17: 7.6 ↓</p> <p>18: 6.9 →</p> <p>19: 8.8 ↗</p> <p>20: 7.9 ←</p>
Serie	82.1	Serie	80.3
Total	82.1	Total	162.4

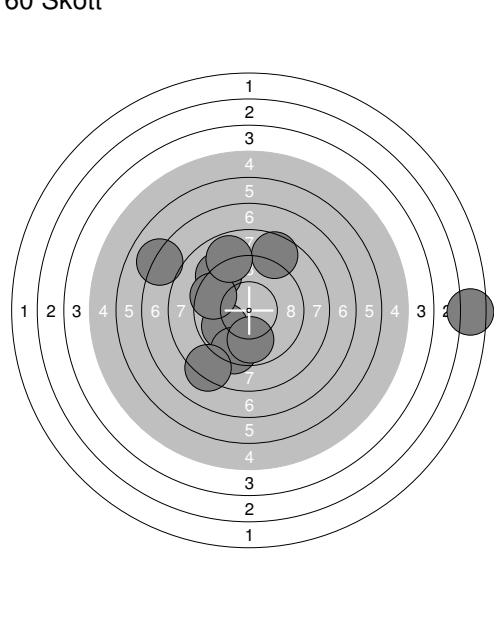
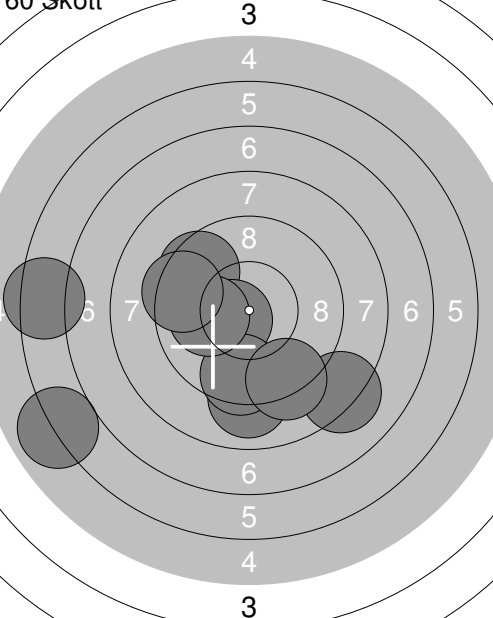
<p>60 Skott</p> 	<p>21: 9.8 ↙</p> <p>22: 9.2 ↖</p> <p>23: 2.4 →</p> <p>24: 9.5 ←</p> <p>25: 9.3 ↓</p> <p>26: 8.6 ↗</p> <p>27: 8.8 ↗</p> <p>28: 8.2 ↓</p> <p>29: 9.8 ↓</p> <p>30: 7.1 ←</p>	<p>60 Skott</p> 	<p>31: 9.5 ↖</p> <p>32: 9.0 ↓</p> <p>33: 10.5x ↙</p> <p>34: 9.5 ↓</p> <p>35: 6.0 ←</p> <p>36: 10.1 ←</p> <p>37: 8.2 ↓</p> <p>38: 9.4 ←</p> <p>39: 9.2 ↓</p> <p>40: 6.4 ←</p>
Serie	82.7	Serie	87.8
Total	245.1	Total	332.9

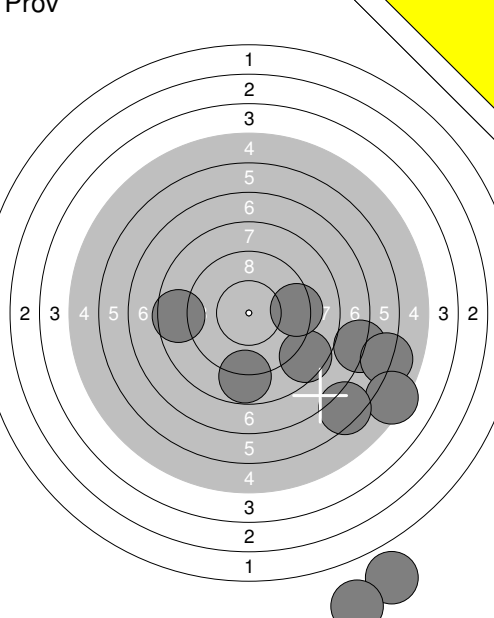
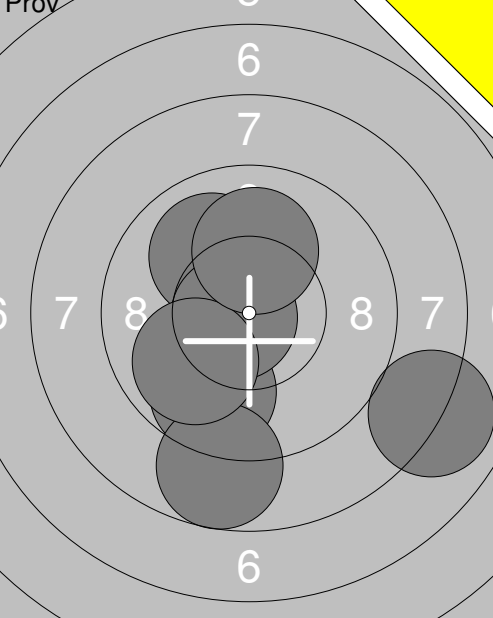
<p>Prov</p> 	<p>1: 7.0 →</p> <p>2: 0.0 ↓</p> <p>3: 6.0 →</p> <p>4: 5.3 ↓</p> <p>5: 0.0 ↓</p> <p>6: 6.4 ↓</p> <p>7: 8.5 ↓</p> <p>8: 9.3 →</p> <p>9: 8.5 ←</p> <p>10: 8.8 ↓</p> <p>Serie 59.8</p> <p>Total 0.0</p>	<p>Prov</p> 	<p>11: 10.0 ↖</p> <p>12: 9.7 ↓</p> <p>13: 10.7 ✕</p> <p>14: 8.7 ↓</p> <p>15: 9.9 ↙</p> <p>16: 10.1 ↑</p> <p>17: 8.0 →</p> <p>Serie 67.1</p> <p>Total 0.0</p>
--	---	--	--

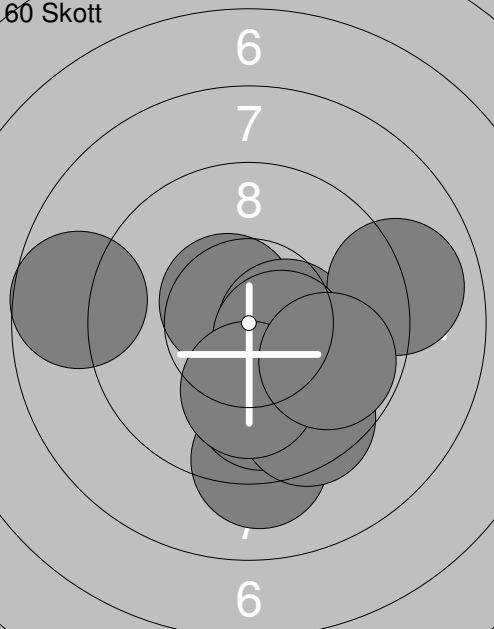
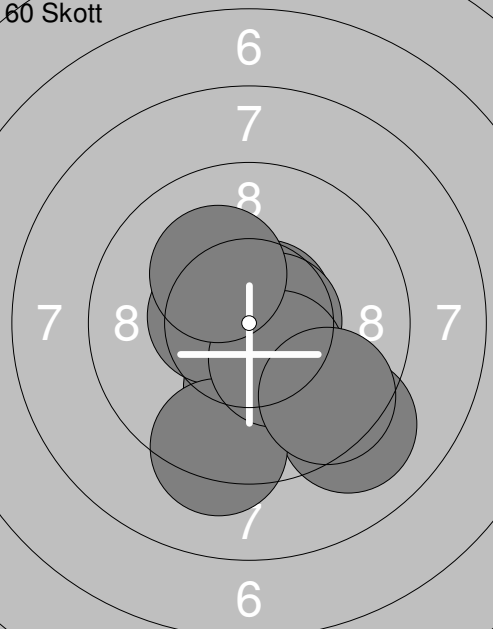
<p>60 Skott</p> 	<p>1: 10.6 ✕</p> <p>2: 9.2 ↓</p> <p>3: 10.5 ✕</p> <p>4: 8.7 ←</p> <p>5: 9.0 →</p> <p>6: 10.5 ✕</p> <p>7: 9.9 ↓</p> <p>8: 9.5 ↓</p> <p>9: 10.1 ↓</p> <p>10: 9.8 →</p> <p>Serie 97.8</p> <p>Total 97.8</p>	<p>60 Skott</p> 	<p>11: 10.7 ✕</p> <p>12: 9.1 ↓</p> <p>13: 10.6 ✕</p> <p>14: 10.1 ↓</p> <p>15: 10.3 ✕</p> <p>16: 10.5 ✕</p> <p>17: 9.3 ↓</p> <p>18: 10.4 ✕</p> <p>19: 10.2 ✕</p> <p>20: 9.6 ↓</p> <p>Serie 100.8</p> <p>Total 198.6</p>
---	--	---	--

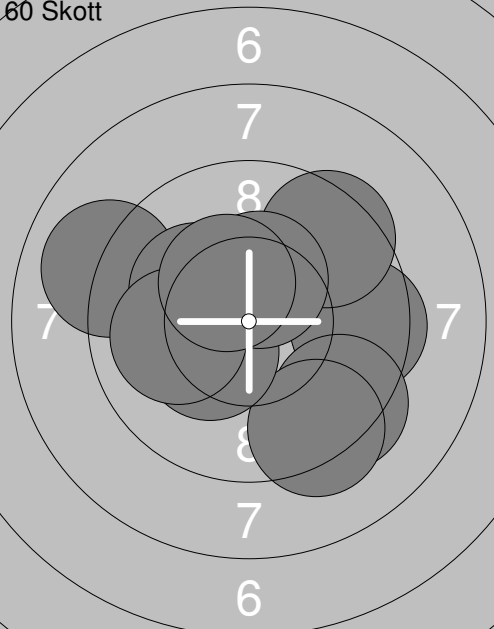
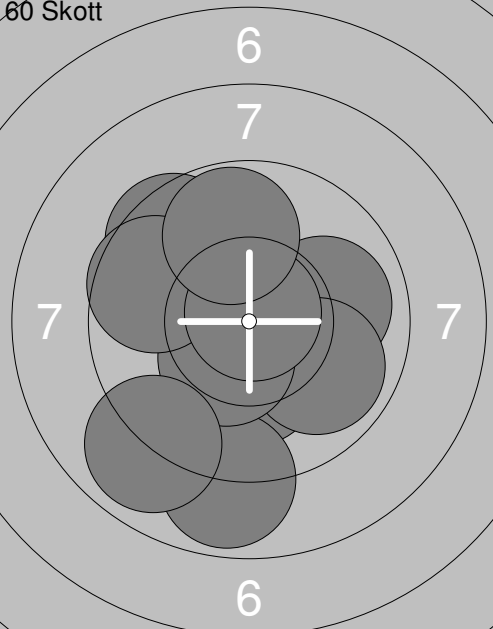
<p>60 Skott</p> 	<p>21: 9.0 ←</p> <p>22: 9.5 →</p> <p>23: 9.4 ↓</p> <p>24: 9.3 ↓</p> <p>25: 10.2 ✕</p> <p>26: 10.3 ✕</p> <p>27: 10.0 ←</p> <p>28: 9.5 ↗</p> <p>29: 10.4 ✕</p> <p>30: 10.4 ✕</p> <p>Serie 98.0</p> <p>Total 296.6</p>	<p>60 Skott</p> 	<p>31: 10.2 ✕</p> <p>32: 10.0 →</p> <p>33: 9.9 →</p> <p>34: 8.9 ↓</p> <p>35: 10.4 ✕</p> <p>36: 9.5 ↖</p> <p>37: 8.9 ↓</p> <p>38: 9.6 ←</p> <p>39: 10.8 ✕</p> <p>40: 9.8 ↑</p> <p>Serie 98.0</p> <p>Total 394.6</p>
--	---	--	--

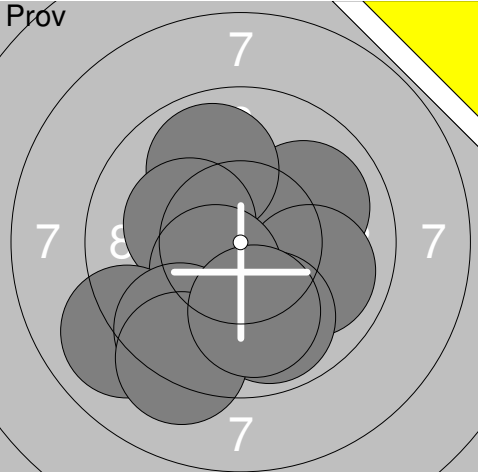
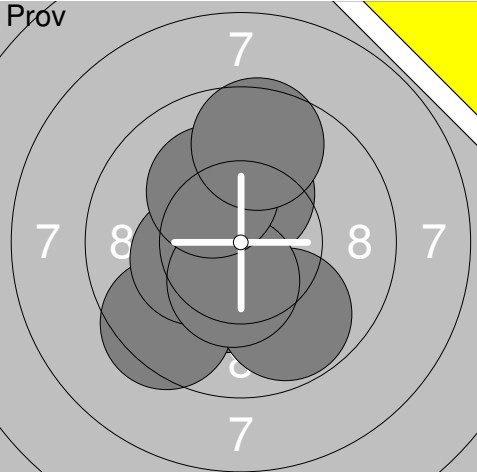
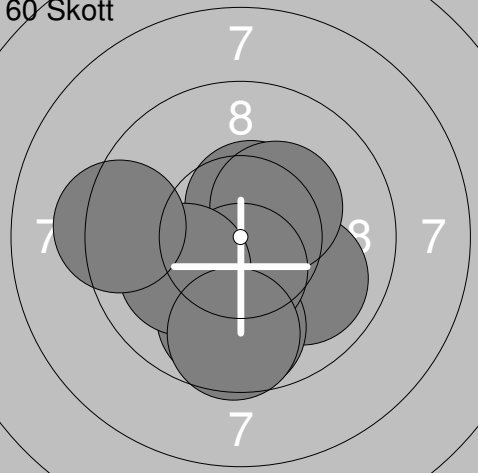
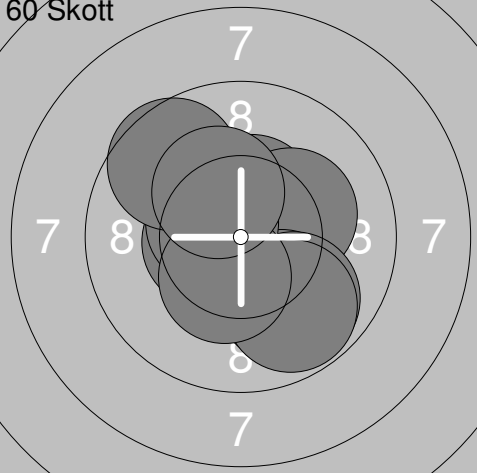
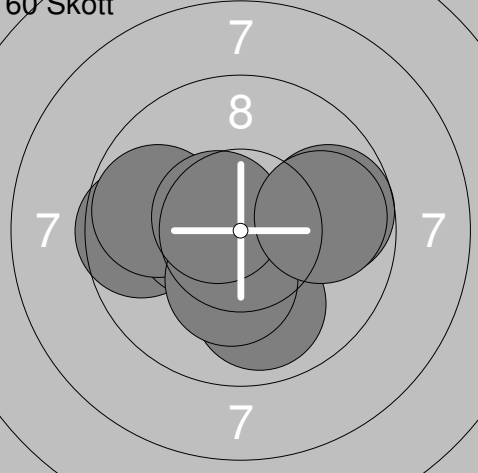
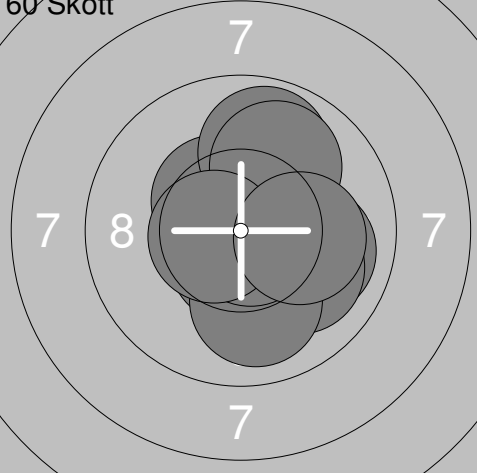
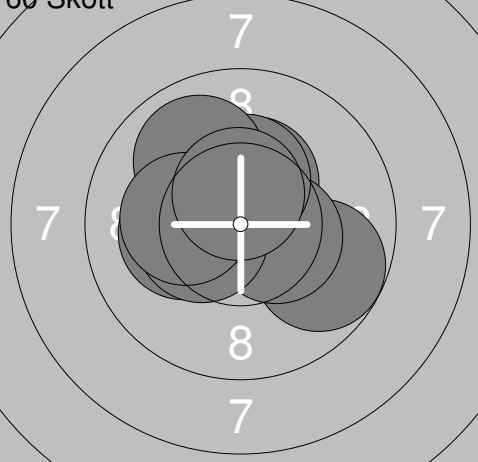
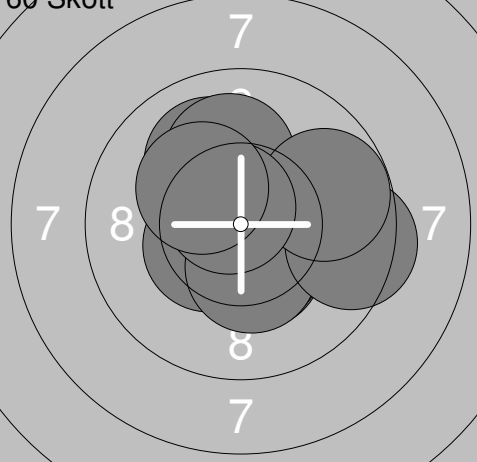
Skjutlag 3	Tavla 7	Oscar Jacobsson			
S		Ramselefors Skf			
08.04.2017		UMEKULAN 2017	Umeå skytteallians		
Pröv		1: 10.0 → 2: 9.9 ↗ 3: 10.2x ↗ 4: 9.9 → 5: 9.9 ↓ 6: 10.4x ↘ 7: 9.0 ← 8: 9.5 ↘ 9: 9.2 ↘ 10: 10.0 ↓ Serie 98.0 Total 0.0	Pröv		11: 10.3x ↓ 12: 9.5 ↘ 13: 10.3x ← 14: 10.3x ↑ 15: 9.8 ↓ 16: 10.4x ↓ 17: 10.2x ↗ 18: 9.6 ↑ Serie 80.4 Total 0.0
60 Skott		1: 10.0 → 2: 10.5x ↗ 3: 10.2x ↘ 4: 10.3x ↗ 5: 9.7 ↓ 6: 9.8 ↓ 7: 10.5x ↓ 8: 10.1 ← 9: 9.6 ↓ 10: 9.3 ← Serie 100.0 Total 100.0	60 Skott		11: 10.4x ↑ 12: 10.5x ← 13: 10.2x → 14: 10.0 ↓ 15: 9.9 ↓ 16: 10.5x ↗ 17: 9.8 ↓ 18: 9.6 ↗ 19: 10.4x ↓ 20: 10.3x ↗ Serie 101.6 Total 201.6
60 Skott		21: 10.7x ↓ 22: 10.4x ↓ 23: 9.6 ← 24: 10.4x ← 25: 9.8 ← 26: 9.9 ↓ 27: 9.7 → 28: 10.3x ↓ 29: 10.6x ↗ 30: 9.9 → Serie 101.3 Total 302.9	60 Skott		31: 10.0 → 32: 10.4x ↗ 33: 10.0 ↓ 34: 10.6x ↓ 35: 9.9 ↑ 36: 10.0 ↓ 37: 10.8x ↓ 38: 10.0 ↑ 39: 10.6x ← 40: 10.1 → Serie 102.4 Total 405.3
60 Skott		41: 10.4x ↗ 42: 9.7 → 43: 10.4x → 44: 10.2x ← 45: 10.4x ↑ 46: 10.4x ← 47: 10.4x ← 48: 9.9 ↗ 49: 10.2x ← 50: 10.5x ↑ Serie 102.5 Total 507.8	60 Skott		51: 10.0 ↗ 52: 10.4x ↓ 53: 10.1 ↑ 54: 10.4x ↓ 55: 10.4x ← 56: 10.4x ↓ 57: 9.4 → 58: 9.8 → 59: 10.7x ↗ 60: 10.2x ↗ Serie 101.8 Total 609.6

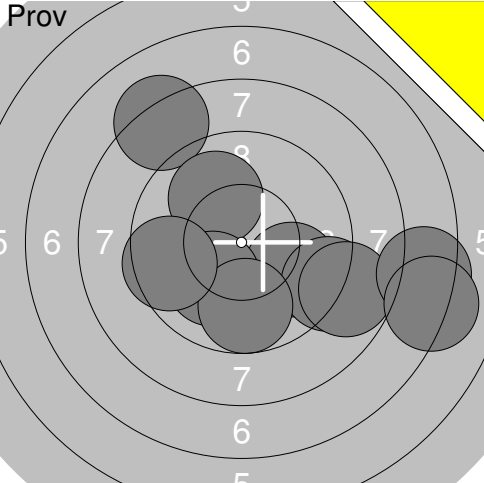
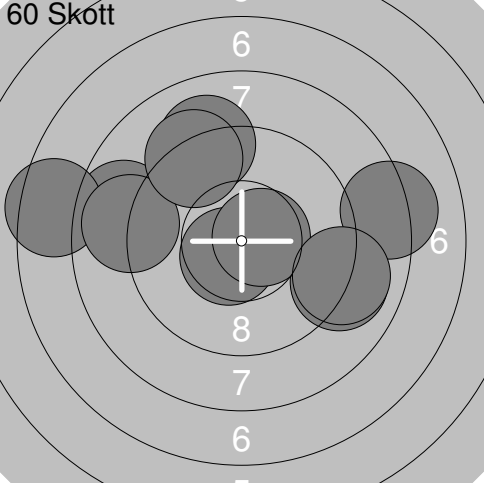
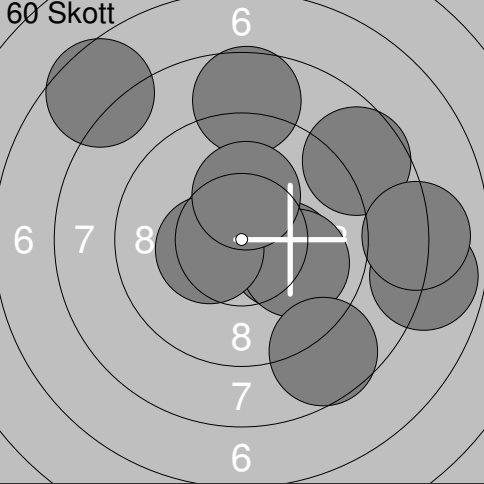
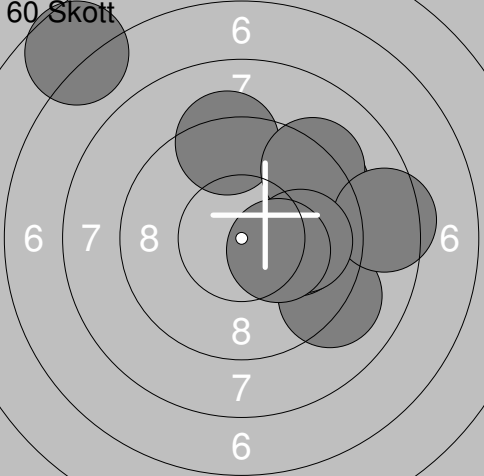
Skjutlag	Tavla	Mattias Lind	
3	8		
S	Skoga-Ekshärad Skf		
08.04.2017	UMEKULAN 2017	Umeå skytteallians	
Prov		1: 8.2 ↗ 2: 9.9 ↘ 3: 10.0 ↗ 4: 9.1 ↘ 5: 10.1 ↘ 6: 8.8 ↘ 7: 7.5 → 8: 9.7 ↘ 9: 7.2 → 10: 9.5 ←	11: 8.7 ← 12: 9.4 ↓ 13: 9.6 ↗ 14: 8.9 → 15: 9.7 ↘ 16: 8.5 →
	Serie 90.0		Serie 54.8
	Total 0.0		Total 0.0
60 Skott		1: 8.7 ← 2: 9.0 ↘ 3: 7.5 ← 4: 10.6x ↘ 5: 8.9 ← 6: 8.2 → 7: 9.1 ↗ 8: 10.6x → 9: 9.2 ↗ 10: 9.0 ↘	11: 8.5 ↗ 12: 8.6 ↘ 13: 9.8 ← 14: 8.9 ↑ 15: 9.1 → 16: 7.6 ↘ 17: 8.1 ↗ 18: 7.1 → 19: 9.6 ← 20: 10.3x →
	Serie 90.8		Serie 87.6
	Total 90.8		Total 178.4
60 Skott		21: 8.7 ↗ 22: 7.9 → 23: 10.2x ↘ 24: 10.0 → 25: 8.6 ↑ 26: 8.1 → 27: 10.4x ← 28: 10.2x ↑ 29: 7.6 ↗ 30: 8.7 ↘	31: 8.9 ← 32: 9.6 ↘ 33: 9.5 ↘ 34: 8.0 ↗ 35: 9.5 → 36: 9.7 → 37: 9.8 ↘ 38: 9.8 ← 39: 10.3x ↑ 40: 10.5x ↘
	Serie 90.4		Serie 95.6
	Total 268.8		Total 364.4
60 Skott		41: 9.6 → 42: 9.4 ↗ 43: 9.3 ↑ 44: 9.1 ↘ 45: 10.0 → 46: 9.2 ↗ 47: 6.7 ↗ 48: 8.5 → 49: 9.9 → 50: 10.3x ↘	51: 10.4x ↘ 52: 8.4 ← 53: 10.2x ↗ 54: 8.8 ← 55: 9.6 ← 56: 10.0 ↗ 57: 7.8 → 58: 10.7x ↗ 59: 9.2 ↗ 60: 7.5 →
	Serie 92.0		Serie 92.6
	Total 456.4		Total 549.0

Skjutlag 3	Tavla 9	Ida Lundmark	
S		Drängsmarks Skf	
08.04.2017		UMEKULAN 2017	
Umeå skytteallians			
Prov 	1: 8.8 → 2: 9.8 ↓ 3: 7.7 ← 4: 9.7 ↓ 5: 9.7 ↓ 6: 8.9 ← 7: 8.6 ← 8: 8.3 → 9: 8.2 → 10: 9.5 → Serie 89.2 Total 0.0	Prov 	11: 9.0 ↓ 12: 10.4x → 13: 10.5x ↗ 14: 8.8 ↗ 15: 9.4 ↗ 16: 8.4 → 17: 9.3 ↗ 18: 9.6 ↗ 19: 9.5 → 20: 7.8 ↗ Serie 92.7 Total 0.0
Prov 	21: 9.4 → 22: 9.4 ↗ 23: 9.8 → 24: 10.1 ↗ 25: 10.0 ↓ 26: 8.2 ↓ 27: 5.7 ← Serie 62.6 Total 0.0	60 Skott 	1: 8.7 → 2: 9.7 ↓ 3: 10.2x ↓ 4: 9.3 ↗ 5: 9.0 → 6: 10.3x ↓ 7: 8.1 ← 8: 10.1 ↓ 9: 9.5 ← 10: 10.8x ↓ Serie 95.7 Total 95.7
60 Skott 	11: 9.6 ← 12: 9.5 → 13: 10.6x ← 14: 8.2 → 15: 8.0 → 16: 10.2x ↓ 17: 10.1 ↓ 18: 9.1 ↗ 19: 10.0 ↓ 20: 9.1 ↓ Serie 94.4 Total 190.1	60 Skott 	21: 10.0 ↗ 22: 10.5x ↗ 23: 10.1 ↓ 24: 10.0 → 25: 7.5 → 26: 10.4x ← 27: 10.1 ↓ 28: 7.3 ↗ 29: 10.0 ↗ 30: 9.7 ↓ Serie 95.6 Total 285.7
60 Skott 	31: 9.5 → 32: 8.6 ↓ 33: 9.5 → 34: 8.0 ← 35: 9.5 ↗ 36: 9.8 → 37: 9.6 → 38: 8.2 → 39: 10.0 ↗ 40: 10.3x ↗ Serie 93.0 Total 378.7		

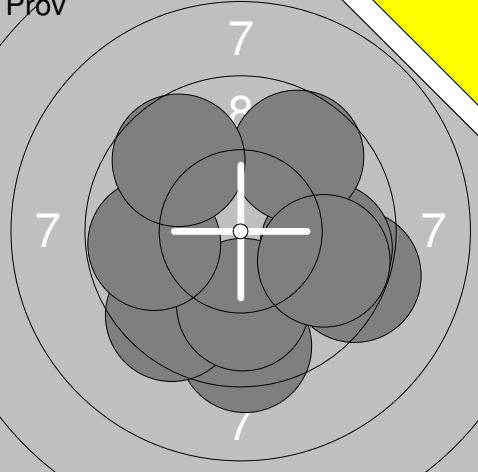
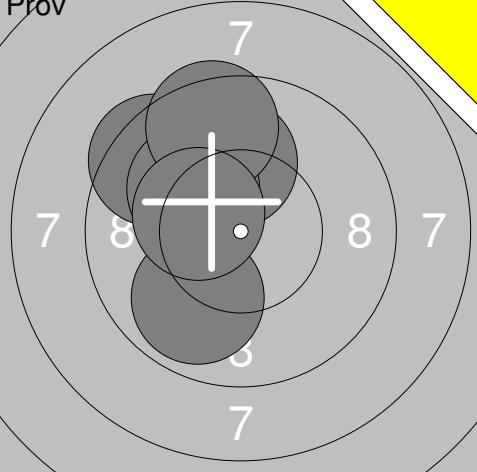

<p>Pröv</p>	<table border="1" style="width:100%; border-collapse: collapse;"> <tr><td>1:</td><td>9.8</td><td>↓</td></tr> <tr><td>2:</td><td>8.6</td><td>→</td></tr> <tr><td>3:</td><td>9.5</td><td>↑</td></tr> <tr><td>4:</td><td>9.9</td><td>→</td></tr> <tr><td>5:</td><td>9.1</td><td>→</td></tr> <tr><td>6:</td><td>10.6x</td><td>↘</td></tr> <tr><td>7:</td><td>7.7</td><td>→</td></tr> <tr><td>8:</td><td>9.2</td><td>→</td></tr> <tr><td>9:</td><td>9.0</td><td>→</td></tr> <tr><td>10:</td><td>10.0</td><td>←</td></tr> <tr><td colspan="2">Serie</td><td>93.4</td></tr> <tr><td colspan="2">Total</td><td>0.0</td></tr> </table>	1:	9.8	↓	2:	8.6	→	3:	9.5	↑	4:	9.9	→	5:	9.1	→	6:	10.6x	↘	7:	7.7	→	8:	9.2	→	9:	9.0	→	10:	10.0	←	Serie		93.4	Total		0.0	<p>Pröv</p>	<table border="1" style="width:100%; border-collapse: collapse;"> <tr><td>11:</td><td>9.9</td><td>↘</td></tr> <tr><td>12:</td><td>10.6x</td><td>→</td></tr> <tr><td>13:</td><td>9.8</td><td>↘</td></tr> <tr><td>14:</td><td>9.4</td><td>↘</td></tr> <tr><td>15:</td><td>10.1</td><td>↘</td></tr> <tr><td>16:</td><td>9.9</td><td>↘</td></tr> <tr><td>17:</td><td>10.2x</td><td>→</td></tr> <tr><td>18:</td><td>9.2</td><td>↘</td></tr> <tr><td colspan="2">Serie</td><td>79.1</td></tr> <tr><td colspan="2">Total</td><td>0.0</td></tr> </table>	11:	9.9	↘	12:	10.6x	→	13:	9.8	↘	14:	9.4	↘	15:	10.1	↘	16:	9.9	↘	17:	10.2x	→	18:	9.2	↘	Serie		79.1	Total		0.0						
1:	9.8	↓																																																																									
2:	8.6	→																																																																									
3:	9.5	↑																																																																									
4:	9.9	→																																																																									
5:	9.1	→																																																																									
6:	10.6x	↘																																																																									
7:	7.7	→																																																																									
8:	9.2	→																																																																									
9:	9.0	→																																																																									
10:	10.0	←																																																																									
Serie		93.4																																																																									
Total		0.0																																																																									
11:	9.9	↘																																																																									
12:	10.6x	→																																																																									
13:	9.8	↘																																																																									
14:	9.4	↘																																																																									
15:	10.1	↘																																																																									
16:	9.9	↘																																																																									
17:	10.2x	→																																																																									
18:	9.2	↘																																																																									
Serie		79.1																																																																									
Total		0.0																																																																									
<p>60 Skott</p>	<table border="1" style="width:100%; border-collapse: collapse;"> <tr><td>1:</td><td>8.9</td><td>←</td></tr> <tr><td>2:</td><td>10.1</td><td>↓</td></tr> <tr><td>3:</td><td>8.1</td><td>→</td></tr> <tr><td>4:</td><td>9.4</td><td>→</td></tr> <tr><td>5:</td><td>8.2</td><td>→</td></tr> <tr><td>6:</td><td>9.1</td><td>↘</td></tr> <tr><td>7:</td><td>10.8x</td><td>←</td></tr> <tr><td>8:</td><td>9.7</td><td>↓</td></tr> <tr><td>9:</td><td>9.8</td><td>←</td></tr> <tr><td>10:</td><td>10.1</td><td>←</td></tr> <tr><td colspan="2">Serie</td><td>94.2</td></tr> <tr><td colspan="2">Total</td><td>94.2</td></tr> </table>	1:	8.9	←	2:	10.1	↓	3:	8.1	→	4:	9.4	→	5:	8.2	→	6:	9.1	↘	7:	10.8x	←	8:	9.7	↓	9:	9.8	←	10:	10.1	←	Serie		94.2	Total		94.2	<p>60 Skott</p>	<table border="1" style="width:100%; border-collapse: collapse;"> <tr><td>11:</td><td>9.9</td><td>→</td></tr> <tr><td>12:</td><td>10.3x</td><td>↘</td></tr> <tr><td>13:</td><td>8.9</td><td>↘</td></tr> <tr><td>14:</td><td>9.9</td><td>↑</td></tr> <tr><td>15:</td><td>9.9</td><td>→</td></tr> <tr><td>16:</td><td>9.7</td><td>←</td></tr> <tr><td>17:</td><td>10.6x</td><td>←</td></tr> <tr><td>18:</td><td>9.7</td><td>↓</td></tr> <tr><td>19:</td><td>10.2x</td><td>↖</td></tr> <tr><td>20:</td><td>10.4x</td><td>→</td></tr> <tr><td colspan="2">Serie</td><td>99.5</td></tr> <tr><td colspan="2">Total</td><td>193.7</td></tr> </table>	11:	9.9	→	12:	10.3x	↘	13:	8.9	↘	14:	9.9	↑	15:	9.9	→	16:	9.7	←	17:	10.6x	←	18:	9.7	↓	19:	10.2x	↖	20:	10.4x	→	Serie		99.5	Total		193.7
1:	8.9	←																																																																									
2:	10.1	↓																																																																									
3:	8.1	→																																																																									
4:	9.4	→																																																																									
5:	8.2	→																																																																									
6:	9.1	↘																																																																									
7:	10.8x	←																																																																									
8:	9.7	↓																																																																									
9:	9.8	←																																																																									
10:	10.1	←																																																																									
Serie		94.2																																																																									
Total		94.2																																																																									
11:	9.9	→																																																																									
12:	10.3x	↘																																																																									
13:	8.9	↘																																																																									
14:	9.9	↑																																																																									
15:	9.9	→																																																																									
16:	9.7	←																																																																									
17:	10.6x	←																																																																									
18:	9.7	↓																																																																									
19:	10.2x	↖																																																																									
20:	10.4x	→																																																																									
Serie		99.5																																																																									
Total		193.7																																																																									
<p>60 Skott</p>	<table border="1" style="width:100%; border-collapse: collapse;"> <tr><td>21:</td><td>10.3x</td><td>↖</td></tr> <tr><td>22:</td><td>9.3</td><td>↑</td></tr> <tr><td>23:</td><td>10.0</td><td>↓</td></tr> <tr><td>24:</td><td>7.5</td><td>↘</td></tr> <tr><td>25:</td><td>10.3x</td><td>→</td></tr> <tr><td>26:</td><td>9.6</td><td>←</td></tr> <tr><td>27:</td><td>10.4x</td><td>→</td></tr> <tr><td>28:</td><td>10.9x</td><td>↑</td></tr> <tr><td>29:</td><td>10.4x</td><td>↘</td></tr> <tr><td>30:</td><td>7.7</td><td>→</td></tr> <tr><td colspan="2">Serie</td><td>96.4</td></tr> <tr><td colspan="2">Total</td><td>290.1</td></tr> </table>	21:	10.3x	↖	22:	9.3	↑	23:	10.0	↓	24:	7.5	↘	25:	10.3x	→	26:	9.6	←	27:	10.4x	→	28:	10.9x	↑	29:	10.4x	↘	30:	7.7	→	Serie		96.4	Total		290.1	<p>60 Skott</p>	<table border="1" style="width:100%; border-collapse: collapse;"> <tr><td>31:</td><td>8.5</td><td>↖</td></tr> <tr><td>32:</td><td>9.6</td><td>↖</td></tr> <tr><td>33:</td><td>9.7</td><td>↖</td></tr> <tr><td>34:</td><td>10.1</td><td>↖</td></tr> <tr><td>35:</td><td>10.2x</td><td>↘</td></tr> <tr><td>36:</td><td>9.5</td><td>↘</td></tr> <tr><td>37:</td><td>10.3x</td><td>→</td></tr> <tr><td>38:</td><td>8.9</td><td>↓</td></tr> <tr><td>39:</td><td>9.5</td><td>↖</td></tr> <tr><td>40:</td><td>10.2x</td><td>↘</td></tr> <tr><td colspan="2">Serie</td><td>96.5</td></tr> <tr><td colspan="2">Total</td><td>386.6</td></tr> </table>	31:	8.5	↖	32:	9.6	↖	33:	9.7	↖	34:	10.1	↖	35:	10.2x	↘	36:	9.5	↘	37:	10.3x	→	38:	8.9	↓	39:	9.5	↖	40:	10.2x	↘	Serie		96.5	Total		386.6
21:	10.3x	↖																																																																									
22:	9.3	↑																																																																									
23:	10.0	↓																																																																									
24:	7.5	↘																																																																									
25:	10.3x	→																																																																									
26:	9.6	←																																																																									
27:	10.4x	→																																																																									
28:	10.9x	↑																																																																									
29:	10.4x	↘																																																																									
30:	7.7	→																																																																									
Serie		96.4																																																																									
Total		290.1																																																																									
31:	8.5	↖																																																																									
32:	9.6	↖																																																																									
33:	9.7	↖																																																																									
34:	10.1	↖																																																																									
35:	10.2x	↘																																																																									
36:	9.5	↘																																																																									
37:	10.3x	→																																																																									
38:	8.9	↓																																																																									
39:	9.5	↖																																																																									
40:	10.2x	↘																																																																									
Serie		96.5																																																																									
Total		386.6																																																																									
<p>60 Skott</p>	<table border="1" style="width:100%; border-collapse: collapse;"> <tr><td>41:</td><td>10.3x</td><td>↘</td></tr> <tr><td>42:</td><td>10.1</td><td>↘</td></tr> <tr><td>43:</td><td>9.2</td><td>↖</td></tr> <tr><td>44:</td><td>8.2</td><td>↖</td></tr> <tr><td>45:</td><td>9.0</td><td>↖</td></tr> <tr><td>46:</td><td>8.0</td><td>↘</td></tr> <tr><td>47:</td><td>10.5x</td><td>↘</td></tr> <tr><td>48:</td><td>10.5x</td><td>↖</td></tr> <tr><td>49:</td><td>10.1</td><td>↖</td></tr> <tr><td>50:</td><td>10.4x</td><td>↘</td></tr> <tr><td colspan="2">Serie</td><td>96.3</td></tr> <tr><td colspan="2">Total</td><td>482.9</td></tr> </table>	41:	10.3x	↘	42:	10.1	↘	43:	9.2	↖	44:	8.2	↖	45:	9.0	↖	46:	8.0	↘	47:	10.5x	↘	48:	10.5x	↖	49:	10.1	↖	50:	10.4x	↘	Serie		96.3	Total		482.9	<p>60 Skott</p>	<table border="1" style="width:100%; border-collapse: collapse;"> <tr><td>51:</td><td>10.0</td><td>→</td></tr> <tr><td>52:</td><td>10.2x</td><td>↘</td></tr> <tr><td>53:</td><td>10.4x</td><td>↘</td></tr> <tr><td>54:</td><td>9.7</td><td>↘</td></tr> <tr><td>55:</td><td>9.3</td><td>↑</td></tr> <tr><td>56:</td><td>8.5</td><td>↘</td></tr> <tr><td>57:</td><td>10.6x</td><td>↘</td></tr> <tr><td>58:</td><td>9.3</td><td>←</td></tr> <tr><td>59:</td><td>9.3</td><td>↖</td></tr> <tr><td>60:</td><td>9.7</td><td>↘</td></tr> <tr><td colspan="2">Serie</td><td>97.0</td></tr> <tr><td colspan="2">Total</td><td>579.9</td></tr> </table>	51:	10.0	→	52:	10.2x	↘	53:	10.4x	↘	54:	9.7	↘	55:	9.3	↑	56:	8.5	↘	57:	10.6x	↘	58:	9.3	←	59:	9.3	↖	60:	9.7	↘	Serie		97.0	Total		579.9
41:	10.3x	↘																																																																									
42:	10.1	↘																																																																									
43:	9.2	↖																																																																									
44:	8.2	↖																																																																									
45:	9.0	↖																																																																									
46:	8.0	↘																																																																									
47:	10.5x	↘																																																																									
48:	10.5x	↖																																																																									
49:	10.1	↖																																																																									
50:	10.4x	↘																																																																									
Serie		96.3																																																																									
Total		482.9																																																																									
51:	10.0	→																																																																									
52:	10.2x	↘																																																																									
53:	10.4x	↘																																																																									
54:	9.7	↘																																																																									
55:	9.3	↑																																																																									
56:	8.5	↘																																																																									
57:	10.6x	↘																																																																									
58:	9.3	←																																																																									
59:	9.3	↖																																																																									
60:	9.7	↘																																																																									
Serie		97.0																																																																									
Total		579.9																																																																									

Pröv																																																																											
	<table border="1" style="width:100%; border-collapse: collapse;"> <tr><td>1:</td><td>9.3</td><td>↘</td></tr> <tr><td>2:</td><td>9.8</td><td>→</td></tr> <tr><td>3:</td><td>9.4</td><td>↓</td></tr> <tr><td>4:</td><td>9.5</td><td>↙</td></tr> <tr><td>5:</td><td>10.0</td><td>↓</td></tr> <tr><td>6:</td><td>9.8</td><td>←</td></tr> <tr><td>8:</td><td>9.7</td><td>↗</td></tr> <tr><td>9:</td><td>9.8</td><td>↘</td></tr> <tr><td>10:</td><td>9.7</td><td>↗</td></tr> <tr><td colspan="2">Serie</td><td>87.0</td></tr> <tr><td colspan="2">Total</td><td>0.0</td></tr> </table>	1:	9.3	↘	2:	9.8	→	3:	9.4	↓	4:	9.5	↙	5:	10.0	↓	6:	9.8	←	8:	9.7	↗	9:	9.8	↘	10:	9.7	↗	Serie		87.0	Total		0.0																																									
1:	9.3	↘																																																																									
2:	9.8	→																																																																									
3:	9.4	↓																																																																									
4:	9.5	↙																																																																									
5:	10.0	↓																																																																									
6:	9.8	←																																																																									
8:	9.7	↗																																																																									
9:	9.8	↘																																																																									
10:	9.7	↗																																																																									
Serie		87.0																																																																									
Total		0.0																																																																									
		<table border="1" style="width:100%; border-collapse: collapse;"> <tr><td>11:</td><td>9.9</td><td>↙</td></tr> <tr><td>12:</td><td>10.0</td><td>↑</td></tr> <tr><td>13:</td><td>9.4</td><td>↗</td></tr> <tr><td>14:</td><td>10.1</td><td>↗</td></tr> <tr><td>15:</td><td>9.5</td><td>↑</td></tr> <tr><td>16:</td><td>10.3x</td><td>↖</td></tr> <tr><td colspan="2">Serie</td><td>59.2</td></tr> <tr><td colspan="2">Total</td><td>0.0</td></tr> </table>	11:	9.9	↙	12:	10.0	↑	13:	9.4	↗	14:	10.1	↗	15:	9.5	↑	16:	10.3x	↖	Serie		59.2	Total		0.0																																																	
11:	9.9	↙																																																																									
12:	10.0	↑																																																																									
13:	9.4	↗																																																																									
14:	10.1	↗																																																																									
15:	9.5	↑																																																																									
16:	10.3x	↖																																																																									
Serie		59.2																																																																									
Total		0.0																																																																									
60 Skott		<table border="1" style="width:100%; border-collapse: collapse;"> <tr><td>1:</td><td>8.5</td><td>↑</td></tr> <tr><td>2:</td><td>9.5</td><td>↑</td></tr> <tr><td>3:</td><td>10.1</td><td>↑</td></tr> <tr><td>4:</td><td>10.8x</td><td>→</td></tr> <tr><td>5:</td><td>10.0</td><td>↑</td></tr> <tr><td>6:</td><td>9.8</td><td>↑</td></tr> <tr><td>7:</td><td>10.0</td><td>↗</td></tr> <tr><td>8:</td><td>9.9</td><td>→</td></tr> <tr><td>9:</td><td>9.4</td><td>↑</td></tr> <tr><td>10:</td><td>10.4x</td><td>↓</td></tr> <tr><td colspan="2">Serie</td><td>98.4</td></tr> <tr><td colspan="2">Total</td><td>98.4</td></tr> </table>	1:	8.5	↑	2:	9.5	↑	3:	10.1	↑	4:	10.8x	→	5:	10.0	↑	6:	9.8	↑	7:	10.0	↗	8:	9.9	→	9:	9.4	↑	10:	10.4x	↓	Serie		98.4	Total		98.4	<table border="1" style="width:100%; border-collapse: collapse;"> <tr><td>11:</td><td>9.6</td><td>↑</td></tr> <tr><td>12:</td><td>10.1</td><td>↓</td></tr> <tr><td>13:</td><td>8.8</td><td>←</td></tr> <tr><td>14:</td><td>9.9</td><td>↑</td></tr> <tr><td>15:</td><td>10.0</td><td>←</td></tr> <tr><td>16:</td><td>10.8x</td><td>→</td></tr> <tr><td>17:</td><td>9.3</td><td>↙</td></tr> <tr><td>18:</td><td>9.7</td><td>↑</td></tr> <tr><td>19:</td><td>9.9</td><td>↑</td></tr> <tr><td>20:</td><td>9.6</td><td>↗</td></tr> <tr><td colspan="2">Serie</td><td>97.7</td></tr> <tr><td colspan="2">Total</td><td>196.1</td></tr> </table>	11:	9.6	↑	12:	10.1	↓	13:	8.8	←	14:	9.9	↑	15:	10.0	←	16:	10.8x	→	17:	9.3	↙	18:	9.7	↑	19:	9.9	↑	20:	9.6	↗	Serie		97.7	Total		196.1
1:	8.5	↑																																																																									
2:	9.5	↑																																																																									
3:	10.1	↑																																																																									
4:	10.8x	→																																																																									
5:	10.0	↑																																																																									
6:	9.8	↑																																																																									
7:	10.0	↗																																																																									
8:	9.9	→																																																																									
9:	9.4	↑																																																																									
10:	10.4x	↓																																																																									
Serie		98.4																																																																									
Total		98.4																																																																									
11:	9.6	↑																																																																									
12:	10.1	↓																																																																									
13:	8.8	←																																																																									
14:	9.9	↑																																																																									
15:	10.0	←																																																																									
16:	10.8x	→																																																																									
17:	9.3	↙																																																																									
18:	9.7	↑																																																																									
19:	9.9	↑																																																																									
20:	9.6	↗																																																																									
Serie		97.7																																																																									
Total		196.1																																																																									
60 Skott		<table border="1" style="width:100%; border-collapse: collapse;"> <tr><td>21:</td><td>9.4</td><td>→</td></tr> <tr><td>22:</td><td>10.1</td><td>→</td></tr> <tr><td>23:</td><td>9.9</td><td>→</td></tr> <tr><td>24:</td><td>9.3</td><td>←</td></tr> <tr><td>25:</td><td>10.3x</td><td>→</td></tr> <tr><td>26:</td><td>10.2x</td><td>↗</td></tr> <tr><td>27:</td><td>9.6</td><td>↗</td></tr> <tr><td>28:</td><td>10.8x</td><td>←</td></tr> <tr><td>29:</td><td>10.1</td><td>↓</td></tr> <tr><td>30:</td><td>9.3</td><td>↓</td></tr> <tr><td colspan="2">Serie</td><td>99.0</td></tr> <tr><td colspan="2">Total</td><td>295.1</td></tr> </table>	21:	9.4	→	22:	10.1	→	23:	9.9	→	24:	9.3	←	25:	10.3x	→	26:	10.2x	↗	27:	9.6	↗	28:	10.8x	←	29:	10.1	↓	30:	9.3	↓	Serie		99.0	Total		295.1	<table border="1" style="width:100%; border-collapse: collapse;"> <tr><td>31:</td><td>9.8</td><td>↙</td></tr> <tr><td>32:</td><td>8.8</td><td>→</td></tr> <tr><td>33:</td><td>9.4</td><td>←</td></tr> <tr><td>34:</td><td>10.1</td><td>↖</td></tr> <tr><td>35:</td><td>9.6</td><td>→</td></tr> <tr><td>36:</td><td>9.4</td><td>↙</td></tr> <tr><td>37:</td><td>9.2</td><td>↙</td></tr> <tr><td>38:</td><td>10.5x</td><td>→</td></tr> <tr><td>39:</td><td>10.1</td><td>↗</td></tr> <tr><td>40:</td><td>9.9</td><td>→</td></tr> <tr><td colspan="2">Serie</td><td>96.8</td></tr> <tr><td colspan="2">Total</td><td>391.9</td></tr> </table>	31:	9.8	↙	32:	8.8	→	33:	9.4	←	34:	10.1	↖	35:	9.6	→	36:	9.4	↙	37:	9.2	↙	38:	10.5x	→	39:	10.1	↗	40:	9.9	→	Serie		96.8	Total		391.9
21:	9.4	→																																																																									
22:	10.1	→																																																																									
23:	9.9	→																																																																									
24:	9.3	←																																																																									
25:	10.3x	→																																																																									
26:	10.2x	↗																																																																									
27:	9.6	↗																																																																									
28:	10.8x	←																																																																									
29:	10.1	↓																																																																									
30:	9.3	↓																																																																									
Serie		99.0																																																																									
Total		295.1																																																																									
31:	9.8	↙																																																																									
32:	8.8	→																																																																									
33:	9.4	←																																																																									
34:	10.1	↖																																																																									
35:	9.6	→																																																																									
36:	9.4	↙																																																																									
37:	9.2	↙																																																																									
38:	10.5x	→																																																																									
39:	10.1	↗																																																																									
40:	9.9	→																																																																									
Serie		96.8																																																																									
Total		391.9																																																																									
60 Skott		<table border="1" style="width:100%; border-collapse: collapse;"> <tr><td>41:</td><td>10.5x</td><td>↙</td></tr> <tr><td>42:</td><td>8.1</td><td>→</td></tr> <tr><td>43:</td><td>9.7</td><td>↙</td></tr> <tr><td>44:</td><td>9.1</td><td>→</td></tr> <tr><td>45:</td><td>10.0</td><td>↑</td></tr> <tr><td>46:</td><td>9.9</td><td>↓</td></tr> <tr><td>47:</td><td>10.1</td><td>↗</td></tr> <tr><td>48:</td><td>9.1</td><td>↗</td></tr> <tr><td>49:</td><td>10.7x</td><td>↗</td></tr> <tr><td>50:</td><td>8.7</td><td>→</td></tr> <tr><td colspan="2">Serie</td><td>95.9</td></tr> <tr><td colspan="2">Total</td><td>487.8</td></tr> </table>	41:	10.5x	↙	42:	8.1	→	43:	9.7	↙	44:	9.1	→	45:	10.0	↑	46:	9.9	↓	47:	10.1	↗	48:	9.1	↗	49:	10.7x	↗	50:	8.7	→	Serie		95.9	Total		487.8	<table border="1" style="width:100%; border-collapse: collapse;"> <tr><td>51:</td><td>10.3x</td><td>→</td></tr> <tr><td>52:</td><td>10.2x</td><td>↓</td></tr> <tr><td>53:</td><td>9.8</td><td>↗</td></tr> <tr><td>54:</td><td>9.3</td><td>←</td></tr> <tr><td>55:</td><td>9.8</td><td>↓</td></tr> <tr><td>56:</td><td>10.6x</td><td>↖</td></tr> <tr><td>57:</td><td>10.2x</td><td>→</td></tr> <tr><td>58:</td><td>9.3</td><td>↘</td></tr> <tr><td>59:</td><td>9.8</td><td>↓</td></tr> <tr><td>60:</td><td>10.1</td><td>↗</td></tr> <tr><td colspan="2">Serie</td><td>99.4</td></tr> <tr><td colspan="2">Total</td><td>587.2</td></tr> </table>	51:	10.3x	→	52:	10.2x	↓	53:	9.8	↗	54:	9.3	←	55:	9.8	↓	56:	10.6x	↖	57:	10.2x	→	58:	9.3	↘	59:	9.8	↓	60:	10.1	↗	Serie		99.4	Total		587.2
41:	10.5x	↙																																																																									
42:	8.1	→																																																																									
43:	9.7	↙																																																																									
44:	9.1	→																																																																									
45:	10.0	↑																																																																									
46:	9.9	↓																																																																									
47:	10.1	↗																																																																									
48:	9.1	↗																																																																									
49:	10.7x	↗																																																																									
50:	8.7	→																																																																									
Serie		95.9																																																																									
Total		487.8																																																																									
51:	10.3x	→																																																																									
52:	10.2x	↓																																																																									
53:	9.8	↗																																																																									
54:	9.3	←																																																																									
55:	9.8	↓																																																																									
56:	10.6x	↖																																																																									
57:	10.2x	→																																																																									
58:	9.3	↘																																																																									
59:	9.8	↓																																																																									
60:	10.1	↗																																																																									
Serie		99.4																																																																									
Total		587.2																																																																									

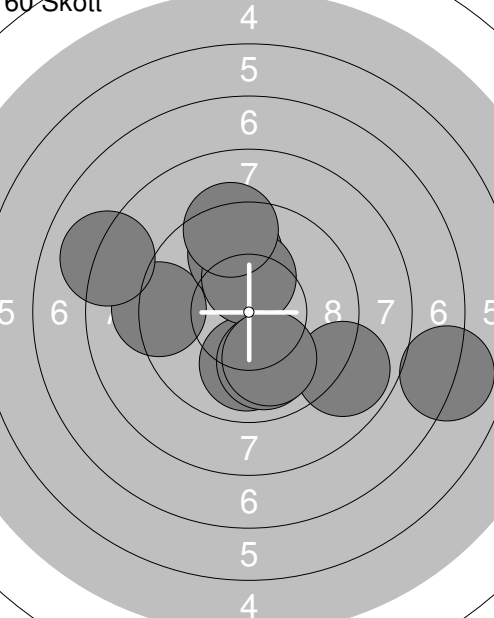
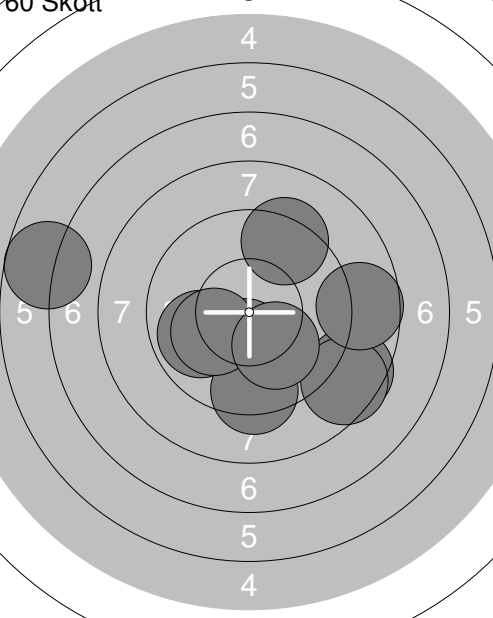
	<p>1: 8.8 ↘ 2: 8.9 ↘ 3: 9.0 ↓ 4: 8.9 ↘ 5: 9.9 ↘ 6: 9.7 ↓ 7: 10.5x ← 8: 8.9 ↘ 9: 7.8 ↘ 10: 9.7 →</p> <p>Serie 92.1 Total 0.0</p>		<p>11: 9.3 ← 12: 8.2 → 13: 10.4x ↘ 14: 10.2x ←</p> <p>Serie 38.1 Total 0.0</p>
--	---	--	--

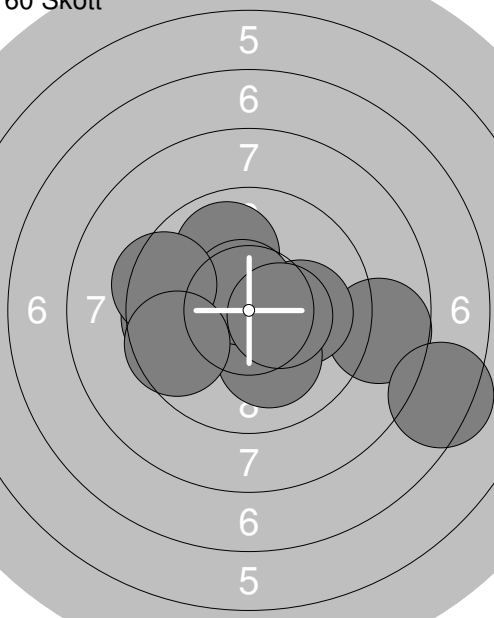
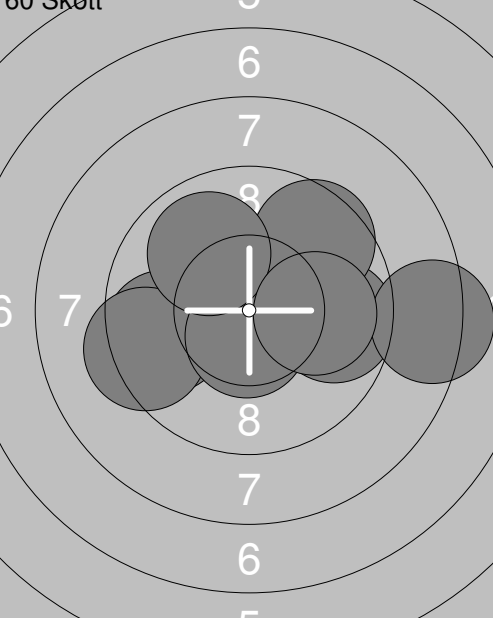
	<p>1: 9.2 ← 2: 9.8 ↑ 3: 8.1 ← 4: 7.0 → 5: 10.0 ↓ 6: 10.3x ↑ 7: 9.3 ↑ 8: 10.0 ↓ 9: 8.9 ↘ 10: 10.0 ↓</p> <p>Serie 92.6 Total 92.6</p>		<p>11: 10.3x ↓ 12: 8.6 → 13: 9.3 ↓ 14: 9.9 ← 15: 9.3 ↑ 16: 8.6 ↘ 17: 10.1 ← 18: 10.1 ↓ 19: 8.7 → 20: 6.7 ←</p> <p>Serie 91.6 Total 184.2</p>
---	---	---	--

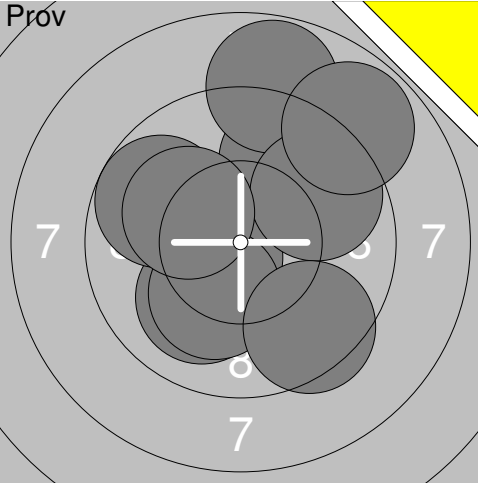
	<p>21: 8.7 → 22: 9.9 ↑ 23: 7.4 → 24: 10.1 → 25: 9.7 ← 26: 10.1 ↓ 27: 10.6x ↑ 28: 9.4 ← 29: 10.4x → 30: 9.6 ←</p> <p>Serie 95.9 Total 280.1</p>		<p>31: 9.7 ← 32: 9.7 → 33: 8.3 → 34: 10.4x ↗ 35: 10.6x ↑ 36: 9.3 ← 37: 9.6 ↗ 38: 10.6x ↓ 39: 9.9 ↖ 40: 10.0 →</p> <p>Serie 98.1 Total 378.2</p>
--	--	--	---

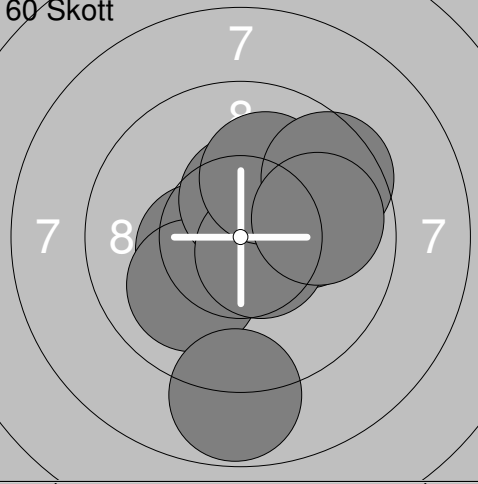
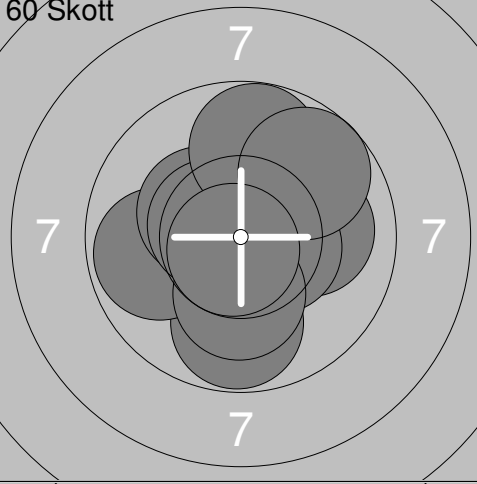
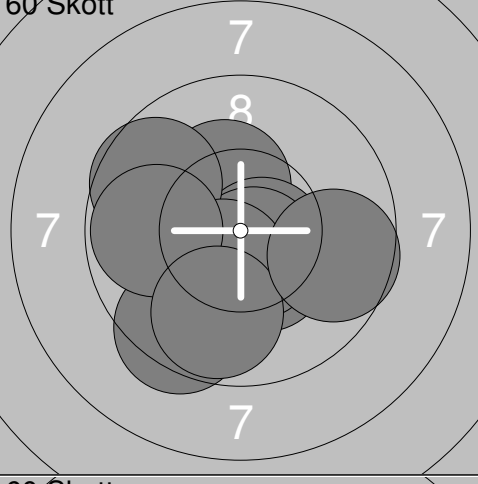
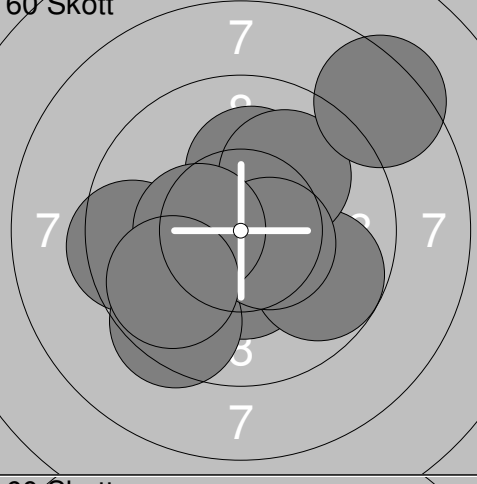
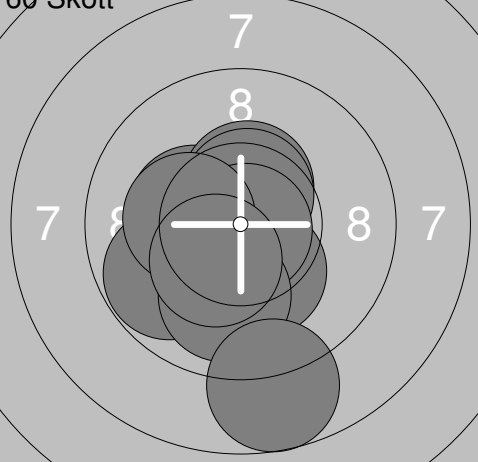
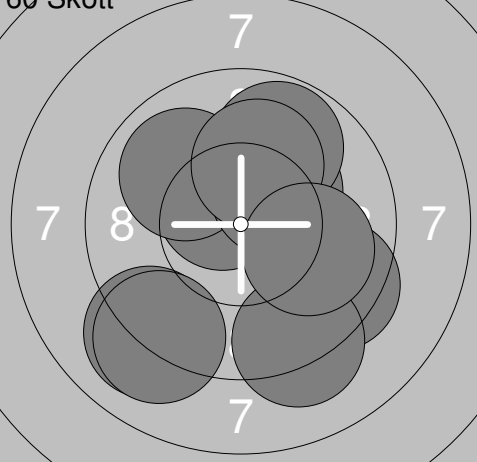
Skjutlag	Tavla	Carl Bergling	
S	Umeå Skf		
08.04.2017	UMEKULAN 2017	Umeå skytteallians	
Pröv		1: 10.6x ↙ 2: 10.0 ↘ 3: 9.7 ↗ 4: 10.2x ↘ 5: 8.8 ↗ 6: 9.7 ↗ 7: 9.7 ↗ 8: 8.8 ↗ 9: 9.5 ↘ 10: 10.1 ↗ Serie 97.1 Total 0.0	Pröv  11: 10.8x ↗ 12: 10.5x ↘ Serie 21.3 Total 0.0
60 Skott		1: 10.7x ↘ 2: 10.4x ← 3: 10.1 → 4: 10.0 ↘ 5: 10.4x ↗ 6: 10.6x ↘ 7: 8.8 ↘ 8: 10.1 ↗ 9: 9.5 ↗ 10: 9.9 → Serie 100.5 Total 100.5	60 Skott  11: 10.0 → 12: 9.8 ↘ 13: 10.5x → 14: 9.8 ← 15: 10.2x ↘ 16: 10.3x ↗ 17: 10.5x ↗ 18: 9.8 ↗ 19: 9.7 ↗ 20: 10.7x ↘ Serie 101.3 Total 201.8
60 Skott		21: 10.3x ↗ 22: 10.4x ↘ 23: 10.6x ↘ 24: 10.6x ↘ 25: 9.6 ↗ 26: 10.4x ↘ 27: 9.4 ↘ 28: 9.8 ← 29: 9.8 ↘ 30: 9.6 → Serie 100.5 Total 302.3	60 Skott  31: 10.4x ↘ 32: 10.2x ↗ 33: 9.8 ↘ 34: 10.0 ↗ 35: 8.4 ↗ 36: 9.5 ← 37: 9.4 ↘ 38: 10.5x → 39: 10.4x ← 40: 9.8 ↘ Serie 98.4 Total 400.7
60 Skott		41: 9.8 ↘ 42: 10.3x ← 43: 10.4x ↗ 44: 10.3x ↘ 45: 10.5x ↗ 46: 10.8x ↘ 47: 10.0 ↘ 48: 8.7 ↘ 49: 10.3x ← 50: 10.4x ↘ Serie 101.5 Total 502.2	60 Skott  51: 9.5 ↘ 52: 10.6x ↗ 53: 9.9 ↗ 54: 9.2 ↘ 55: 10.3x ↗ 56: 9.8 ↗ 57: 10.1 ↗ 58: 9.0 ↘ 59: 10.0 → 60: 9.1 ↘ Serie 97.5 Total 599.7

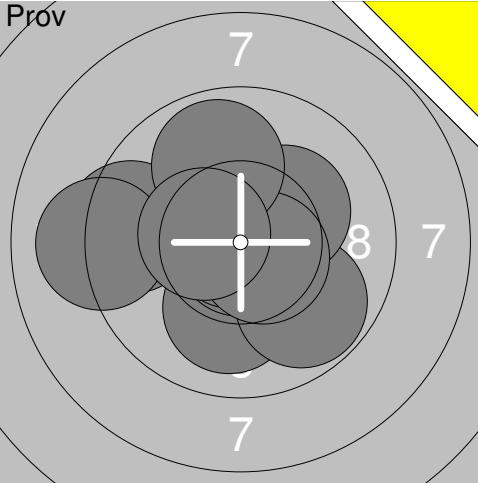
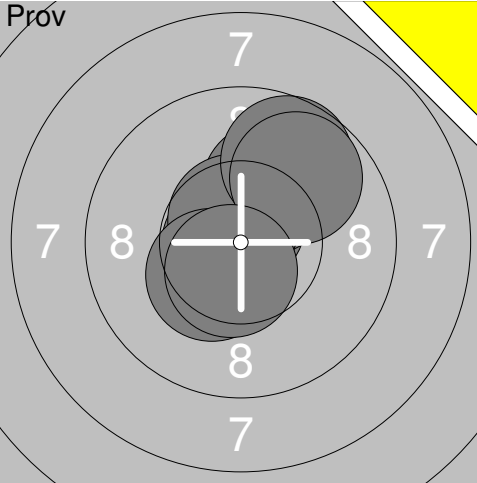
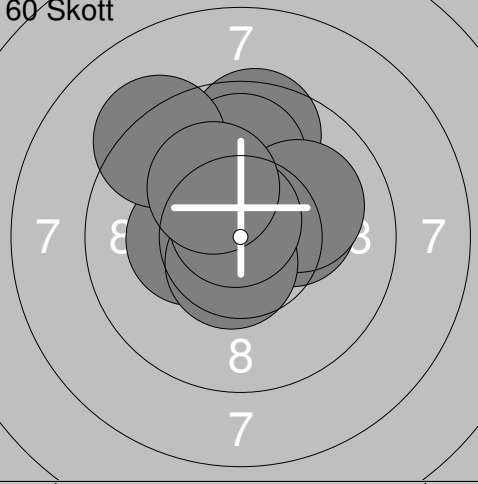
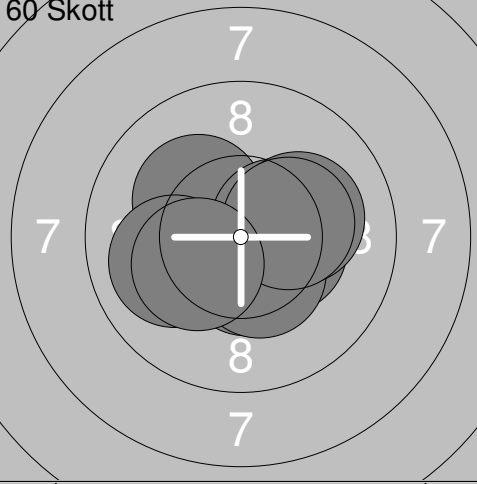
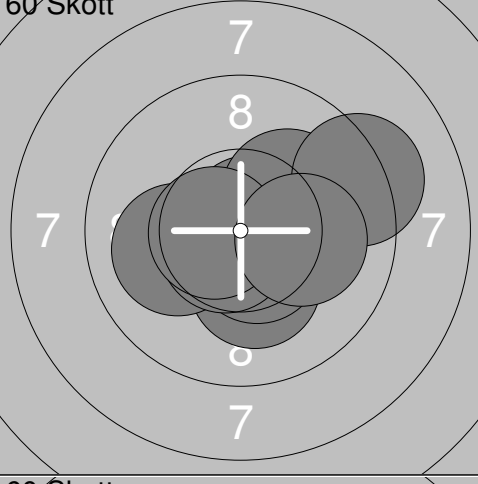
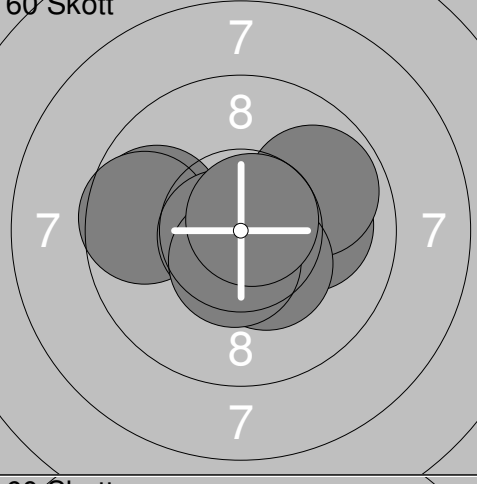
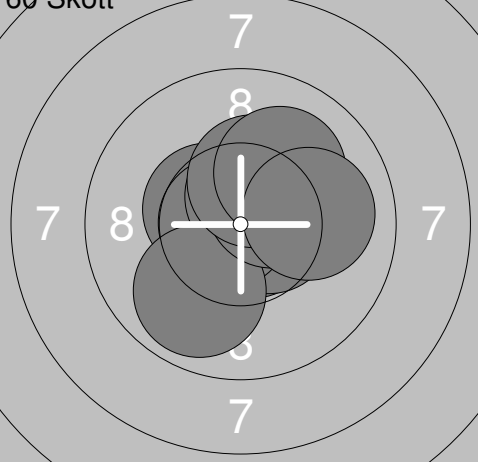
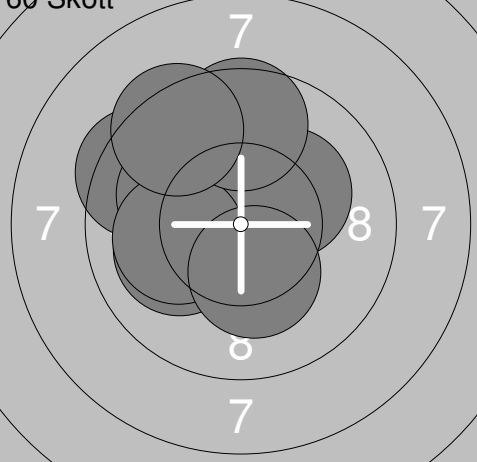
Skjutlag	Tavla	Saul Johansson	
3	15		
S	Ramselefors Skf		
08.04.2017	UMEKULAN 2017	Umeå skytteallians	
Pröv		1: 9.5 ← 2: 9.1 ← 3: 10.1 ↓ 4: 9.8 ↓ 5: 10.8x ↓ 6: 10.2x ↗ 7: 10.9x ← 8: 10.6x ↓ 9: 9.9 ↗ 10: 10.4x ← Serie 101.3 Total 0.0	Pröv  11: 9.8 ↗ 12: 10.7x ↑ 13: 10.8x ← 14: 10.1 ↗ 15: 10.6x ↑ 16: 9.7 ↗ 17: 10.4x ↓ 18: 9.8 ↗ 19: 10.5x ↓ Serie 92.4 Total 0.0
60 Skott		1: 10.7x ↗ 2: 9.6 ↑ 3: 9.9 ↑ 4: 10.3x ← 5: 10.2x → 6: 10.1 → 7: 10.6x ↓ 8: 9.3 ↗ 9: 10.7x ↗ 10: 10.2x ↗ Serie 101.6 Total 101.6	60 Skott  11: 10.7x ← 12: 10.2x ↗ 13: 10.5x ↓ 14: 10.0 ← 15: 10.4x → 16: 10.4x → 17: 10.4x ↓ 18: 10.1 → 19: 10.3x → 20: 10.3x ← Serie 103.3 Total 204.9
60 Skott		21: 10.2x ↓ 22: 10.5x ↓ 23: 10.4x → 24: 10.8x ↗ 25: 10.2x ↗ 26: 10.1 ← 27: 10.7x ↓ 28: 9.2 → 29: 10.6x ← 30: 10.1 → Serie 102.8 Total 307.7	60 Skott  31: 10.7x ↓ 32: 9.8 ← 33: 9.6 ← 34: 10.1 → 35: 10.6x ↓ 36: 10.7x ← 37: 9.8 ↗ 38: 10.4x ↓ 39: 10.5x ↓ 40: 10.7x ↗ Serie 102.9 Total 410.6
60 Skott		41: 10.5x ← 42: 10.8x ↓ 43: 10.6x → 44: 10.7x ← 45: 10.5x ↑ 46: 9.9 ↓ 47: 10.4x ↗ 48: 10.3x ↑ 49: 10.1 ↗ 50: 10.0 → Serie 103.8 Total 514.4	60 Skott  51: 10.4x ↗ 52: 9.4 ← 53: 10.1 ↗ 54: 10.1 ← 55: 10.8x ↓ 56: 10.2x ↗ 57: 10.1 ← 58: 9.6 ↑ 59: 10.3x ↓ 60: 9.4 ↗ Serie 100.4 Total 614.8

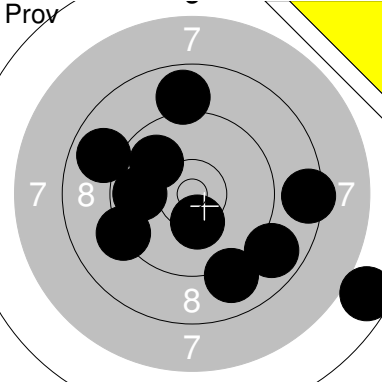
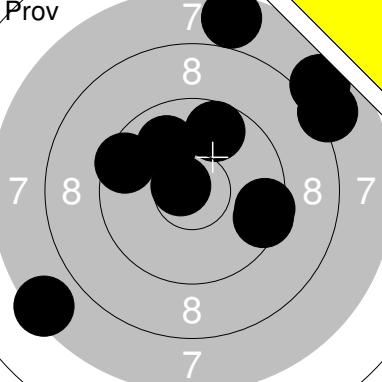
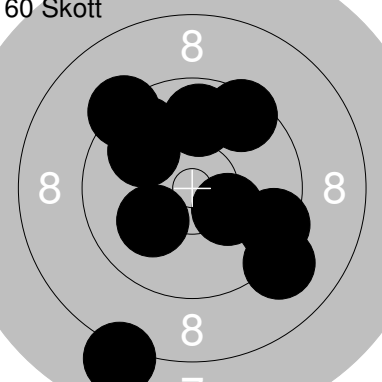
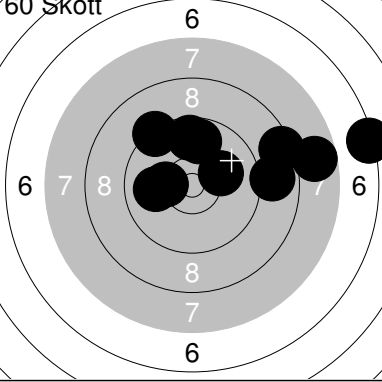
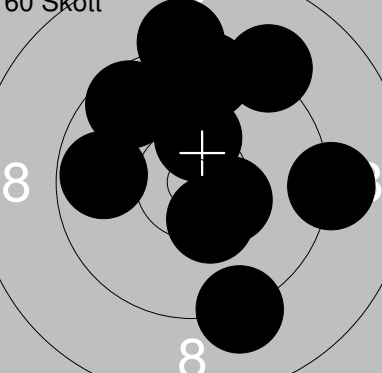
Skjutlag	Tavla	Salman Alkeshaf	
S	Växjö Hif		
08.04.2017	UMEKULAN 2017	Umeå skytteallians	
Prov		1: 8.5 → 2: 10.0 ↗ 3: 10.4x ↓ 4: 8.9 ↓ 5: 6.7 ↓ 6: 8.9 ↗ 7: 9.1 ↓ 8: 9.9 ← 9: 8.9 ↑ 10: 9.3 ↙ Serie 90.6 Total 0.0	11: 9.3 → 12: 10.8x ↓ 13: 8.7 ↖ 14: 8.0 ↗ 15: 9.9 ↑ 16: 10.3 ↗ 17: 9.5 ↑ 18: 8.8 → 19: 10.2 ↗ 20: 8.8 → Serie 94.3 Total 0.0
Prov		21: 7.5 ↙ 22: 7.7 ↑ 23: 9.8 ↑ 24: 8.1 ↗ 25: 10.0 ↗ 26: 10.7x ↖ 27: 9.6 → 28: 9.6 ↖ 29: 7.9 ↗ 30: 9.5 → Serie 90.4 Total 0.0	31: 10.4x ↙ Serie 10.4 Total 0.0
60 Skott		1: 9.3 ↗ 2: 9.6 ↗ 3: 10.0 ↗ 4: 10.3 ↘ 5: 9.9 ↑ 6: 9.8 ↗ 7: 10.2 ↙ 8: 9.6 ↘ 9: 8.1 ↓ 10: 9.2 ↓ Serie 96.0 Total 96.0	11: 10.3 ↑ 12: 10.4x ↙ 13: 9.7 ↓ 14: 10.3 ↓ 15: 9.8 → 16: 7.6 ↘ 17: 9.3 ↘ 18: 8.8 ↗ 19: 9.0 → 20: 10.1 ↑ Serie 95.3 Total 191.3
60 Skott		21: 6.3 → 22: 9.3 ↖ 23: 10.3 ← 24: 9.8 ↑ 25: 8.9 → 26: 8.5 → 27: 10.0 ← 28: 10.2 → 29: 7.8 → 30: 9.7 ↑ Serie 90.8 Total 282.1	31: 8.4 → 32: 8.9 ↗ 33: 9.3 ↑ 34: 9.2 → 35: 9.2 → 36: 8.1 ↑ 37: 9.9 ↗ 38: 9.8 ↓ 39: 10.0 ↙ 40: 7.8 ↓ Serie 90.6 Total 372.7
60 Skott		41: 9.6 ↑ 42: 9.7 ↗ 43: 9.2 ↑ 44: 9.2 → 45: 10.4x ↑ 46: 10.4x ↓ 47: 9.8 ← 48: 10.4x ↘ 49: 9.2 ↓ 50: 9.2 ↗ Serie 97.1 Total 469.8	51: 9.7 → 52: 10.4x → 53: 9.1 ↘ 54: 10.1 ↗ 55: 10.6x → 56: 8.5 ↗ 57: 9.9 ↓ 58: 9.2 ← 59: 9.9 ↗ 60: 10.4 ↑ Serie 97.8 Total 567.6

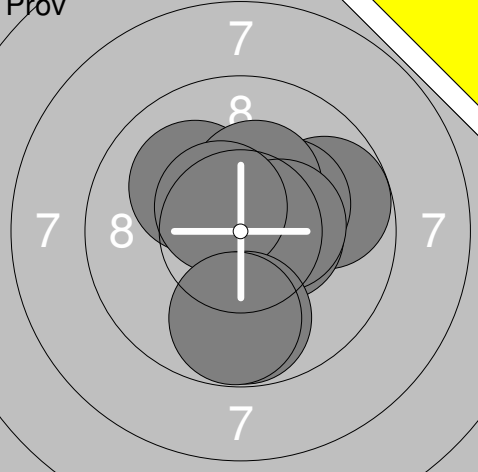
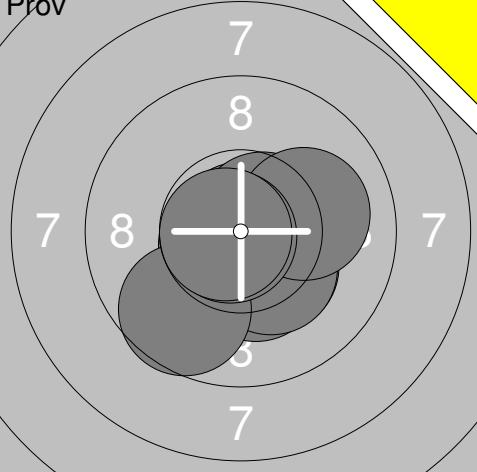
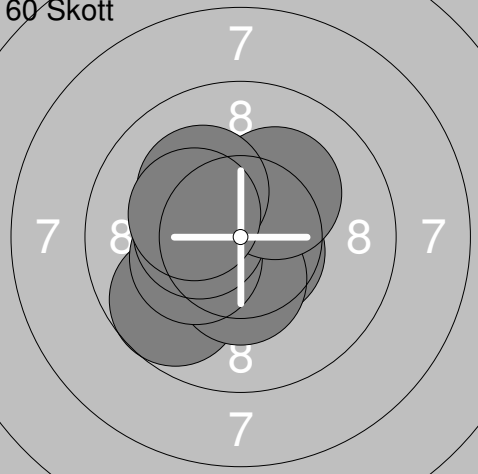
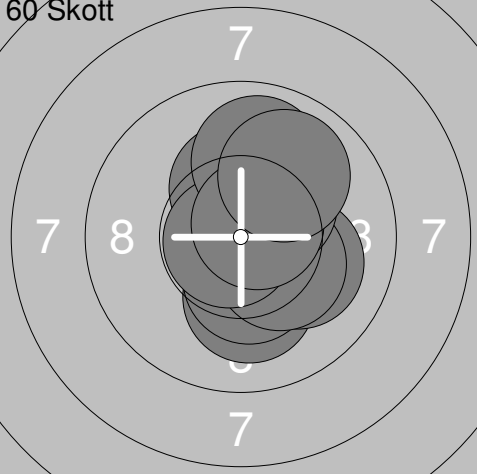
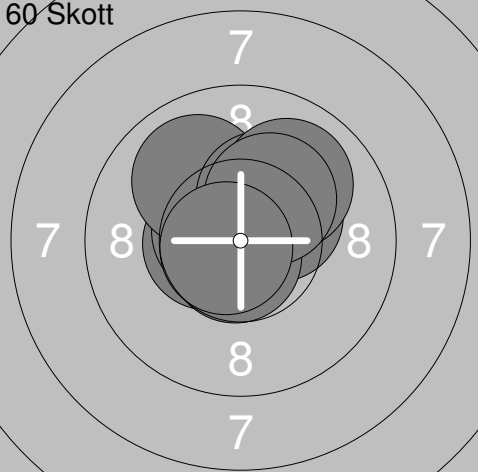
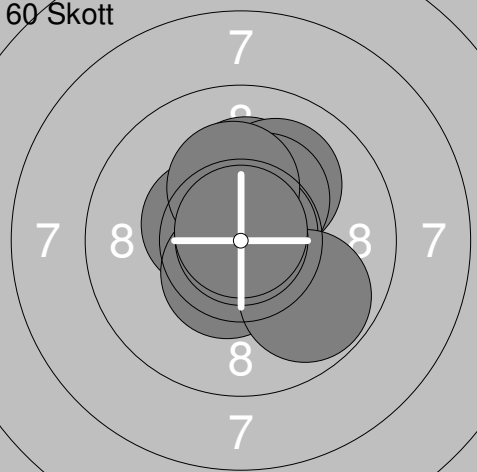
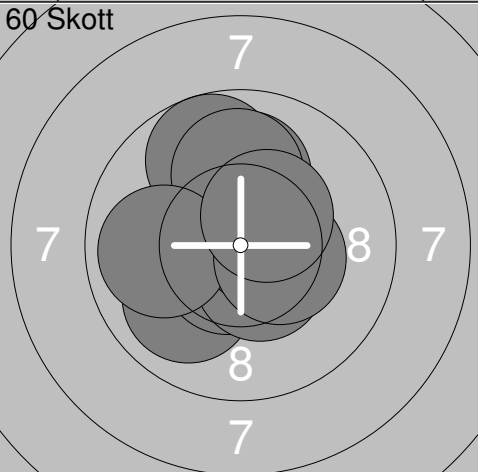
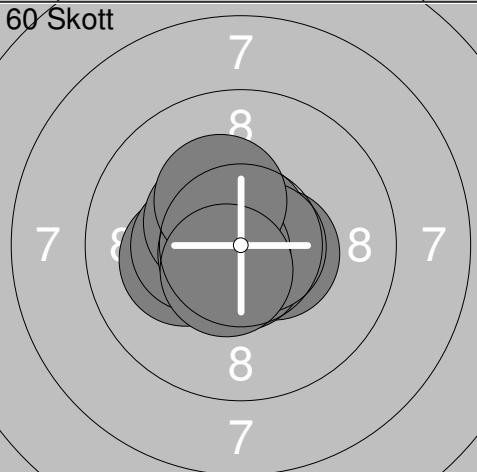
<p>Pröv</p> 	<p>1: 10.7x ↗ 2: 9.8 → 3: 10.3x → 4: 10.1 ↗ 5: 10.3x ↑ 6: 10.5x → 7: 10.4x → 8: 10.5x ↗ 9: 9.8 ↓ 10: 9.8 ↓</p> <p>Serie 102.2 Total 0.0</p>	<p>Pröv</p> 	<p>11: 10.7x ↙ 12: 10.9x ↑ 13: 10.3x ↘ 14: 10.3x ↘ 15: 10.6x → 16: 10.3x ↘ 17: 10.1 → 18: 9.7 ↘ 19: 10.8x ← 20: 10.7x ←</p> <p>Serie 104.4 Total 0.0</p>
<p>60 Skott</p> 	<p>1: 10.4x ↓ 2: 9.7 ↙ 3: 10.4x ↗ 4: 10.6x ↘ 5: 10.4x ↓ 6: 10.3x ← 7: 10.4x ← 8: 10.2x ↗ 9: 10.2x ↗ 10: 10.3x ↗</p> <p>Serie 102.9 Total 102.9</p>	<p>60 Skott</p> 	<p>11: 10.1 ↓ 12: 10.1 → 13: 10.4x ↘ 14: 10.3x → 15: 10.3x ↗ 16: 10.3x ↑ 17: 10.8x ← 18: 9.9 ↑ 19: 10.7x ↗ 20: 9.9 ↗</p> <p>Serie 102.8 Total 205.7</p>
<p>60 Skott</p> 	<p>21: 10.4x ↗ 22: 10.4x ↗ 23: 10.5x ← 24: 10.6x ↙ 25: 10.7x ↓ 26: 10.0 ↗ 27: 10.3x ↗ 28: 10.0 ↗ 29: 10.3x ↗ 30: 10.7x ←</p> <p>Serie 103.9 Total 309.6</p>	<p>60 Skott</p> 	<p>31: 10.2x ↑ 32: 10.4x ↙ 33: 10.5x ↘ 34: 10.1 ↗ 35: 10.3x ↗ 36: 10.8x ↗ 37: 9.8 ↘ 38: 10.2x ↑ 39: 10.9x ↑ 40: 10.8x ↑</p> <p>Serie 104.0 Total 413.6</p>
<p>60 Skott</p> 	<p>41: 10.0 ↙ 42: 10.6x ↘ 43: 10.5x ↘ 44: 9.7 ↗ 45: 10.0 ↑ 46: 10.6x → 47: 10.0 ↑ 48: 9.9 ← 49: 10.4x → 50: 10.4x ↗</p> <p>Serie 102.1 Total 515.7</p>	<p>60 Skott</p> 	<p>51: 10.5x → 52: 10.7x ↑ 53: 10.2x ← 54: 10.7x ↓ 55: 10.7x → 56: 10.4x ← 57: 10.4x ↙ 58: 10.7x ← 59: 10.3x ↗ 60: 10.6x ↘</p> <p>Serie 105.2 Total 620.9</p>

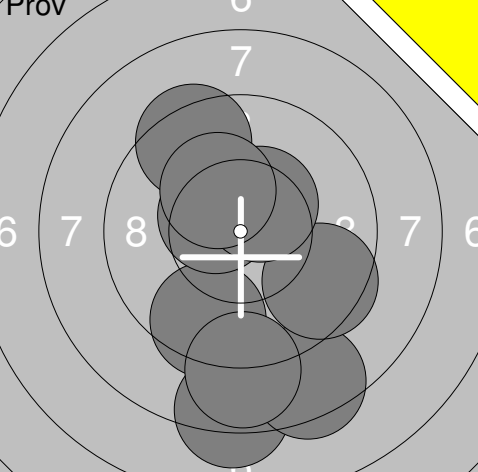
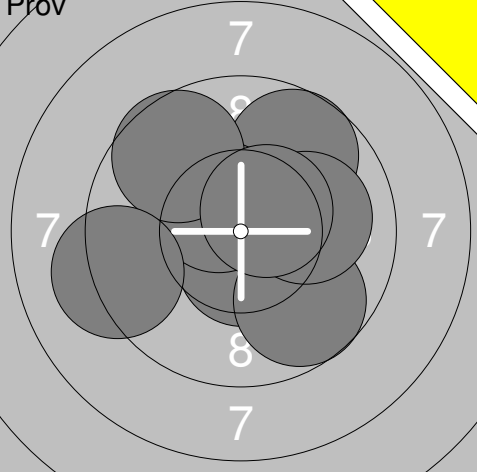
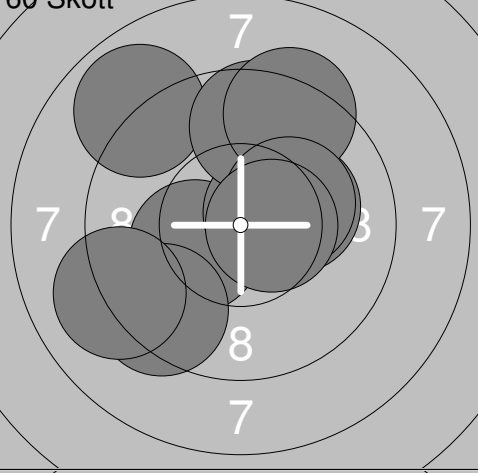
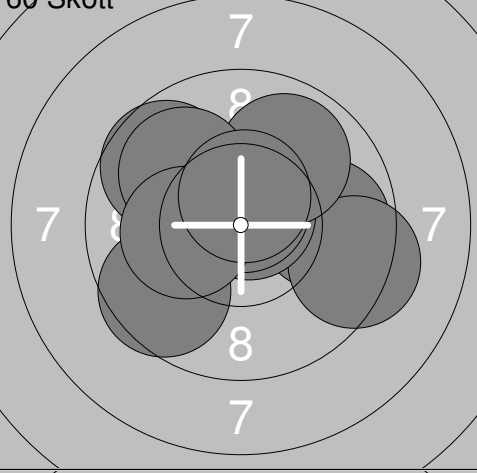
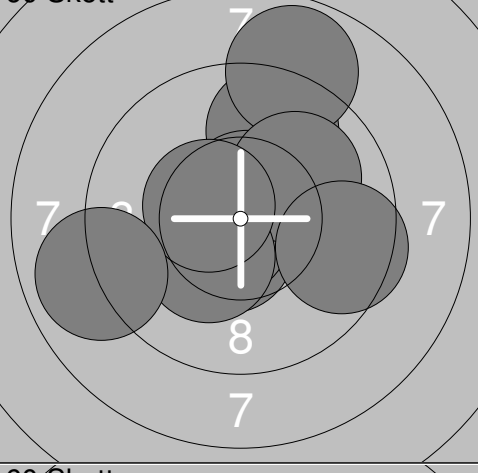
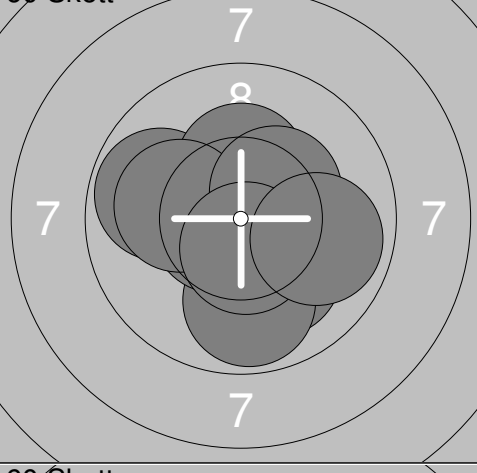
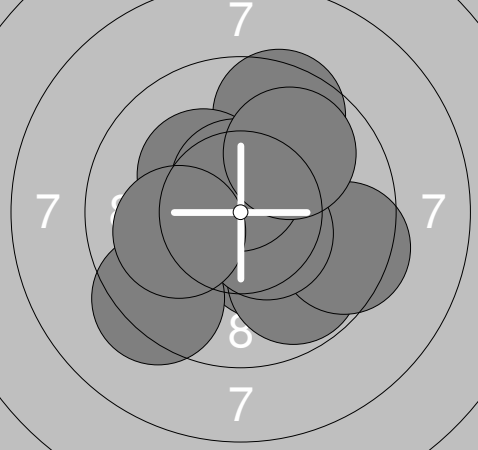
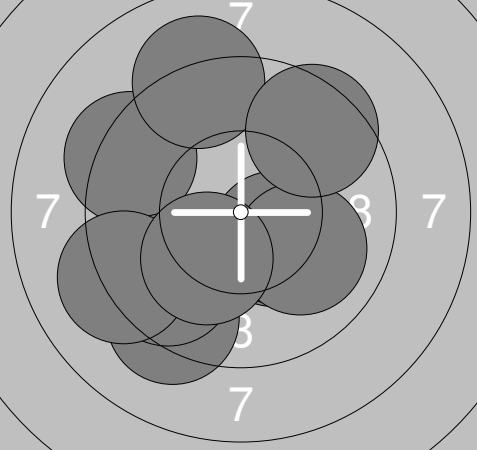
<p>Prov</p> 	<table border="1" style="width:100%; border-collapse: collapse;"> <tr><td>1:</td><td>9.5</td><td>↘</td></tr> <tr><td>2:</td><td>8.2</td><td>↘</td></tr> <tr><td>3:</td><td>8.4</td><td>↘</td></tr> <tr><td>4:</td><td>8.8</td><td>↘</td></tr> <tr><td>5:</td><td>10.5x</td><td>↗</td></tr> <tr><td>6:</td><td>9.5</td><td>↘</td></tr> <tr><td>7:</td><td>9.4</td><td>↗</td></tr> <tr><td>8:</td><td>10.4x</td><td>↗</td></tr> <tr><td>9:</td><td>10.2x</td><td>↗</td></tr> <tr><td colspan="2">Serie</td><td>84.9</td></tr> <tr><td colspan="2">Total</td><td>0.0</td></tr> </table>	1:	9.5	↘	2:	8.2	↘	3:	8.4	↘	4:	8.8	↘	5:	10.5x	↗	6:	9.5	↘	7:	9.4	↗	8:	10.4x	↗	9:	10.2x	↗	Serie		84.9	Total		0.0	<p>Prov</p> 	<table border="1" style="width:100%; border-collapse: collapse;"> <tr><td>11:</td><td>9.7</td><td>↗</td></tr> <tr><td>12:</td><td>10.6x</td><td>↘</td></tr> <tr><td>13:</td><td>9.7</td><td>↘</td></tr> <tr><td>14:</td><td>10.5x</td><td>↗</td></tr> <tr><td>15:</td><td>10.1</td><td>→</td></tr> <tr><td>16:</td><td>9.6</td><td>↗</td></tr> <tr><td>17:</td><td>9.2</td><td>←</td></tr> <tr><td>18:</td><td>10.5x</td><td>↗</td></tr> <tr><td colspan="2">Serie</td><td>79.9</td></tr> <tr><td colspan="2">Total</td><td>0.0</td></tr> </table>	11:	9.7	↗	12:	10.6x	↘	13:	9.7	↘	14:	10.5x	↗	15:	10.1	→	16:	9.6	↗	17:	9.2	←	18:	10.5x	↗	Serie		79.9	Total		0.0									
1:	9.5	↘																																																																									
2:	8.2	↘																																																																									
3:	8.4	↘																																																																									
4:	8.8	↘																																																																									
5:	10.5x	↗																																																																									
6:	9.5	↘																																																																									
7:	9.4	↗																																																																									
8:	10.4x	↗																																																																									
9:	10.2x	↗																																																																									
Serie		84.9																																																																									
Total		0.0																																																																									
11:	9.7	↗																																																																									
12:	10.6x	↘																																																																									
13:	9.7	↘																																																																									
14:	10.5x	↗																																																																									
15:	10.1	→																																																																									
16:	9.6	↗																																																																									
17:	9.2	←																																																																									
18:	10.5x	↗																																																																									
Serie		79.9																																																																									
Total		0.0																																																																									
<p>60 Skott</p> 	<table border="1" style="width:100%; border-collapse: collapse;"> <tr><td>1:</td><td>10.3x</td><td>←</td></tr> <tr><td>2:</td><td>10.2x</td><td>→</td></tr> <tr><td>3:</td><td>10.5x</td><td>→</td></tr> <tr><td>4:</td><td>8.9</td><td>↗</td></tr> <tr><td>5:</td><td>9.6</td><td>↑</td></tr> <tr><td>6:</td><td>9.3</td><td>↑</td></tr> <tr><td>7:</td><td>10.2x</td><td>→</td></tr> <tr><td>8:</td><td>10.5x</td><td>→</td></tr> <tr><td>9:</td><td>9.4</td><td>↘</td></tr> <tr><td>10:</td><td>9.1</td><td>←</td></tr> <tr><td colspan="2">Serie</td><td>98.0</td></tr> <tr><td colspan="2">Total</td><td>98.0</td></tr> </table>	1:	10.3x	←	2:	10.2x	→	3:	10.5x	→	4:	8.9	↗	5:	9.6	↑	6:	9.3	↑	7:	10.2x	→	8:	10.5x	→	9:	9.4	↘	10:	9.1	←	Serie		98.0	Total		98.0	<p>60 Skott</p> 	<table border="1" style="width:100%; border-collapse: collapse;"> <tr><td>11:</td><td>9.8</td><td>→</td></tr> <tr><td>12:</td><td>9.3</td><td>→</td></tr> <tr><td>13:</td><td>9.6</td><td>↘</td></tr> <tr><td>14:</td><td>10.8x</td><td>↗</td></tr> <tr><td>15:</td><td>10.7x</td><td>↑</td></tr> <tr><td>16:</td><td>9.7</td><td>↗</td></tr> <tr><td>17:</td><td>9.9</td><td>↗</td></tr> <tr><td>18:</td><td>9.9</td><td>↗</td></tr> <tr><td>19:</td><td>10.2x</td><td>←</td></tr> <tr><td>20:</td><td>10.6x</td><td>↑</td></tr> <tr><td colspan="2">Serie</td><td>100.5</td></tr> <tr><td colspan="2">Total</td><td>198.5</td></tr> </table>	11:	9.8	→	12:	9.3	→	13:	9.6	↘	14:	10.8x	↗	15:	10.7x	↑	16:	9.7	↗	17:	9.9	↗	18:	9.9	↗	19:	10.2x	←	20:	10.6x	↑	Serie		100.5	Total		198.5
1:	10.3x	←																																																																									
2:	10.2x	→																																																																									
3:	10.5x	→																																																																									
4:	8.9	↗																																																																									
5:	9.6	↑																																																																									
6:	9.3	↑																																																																									
7:	10.2x	→																																																																									
8:	10.5x	→																																																																									
9:	9.4	↘																																																																									
10:	9.1	←																																																																									
Serie		98.0																																																																									
Total		98.0																																																																									
11:	9.8	→																																																																									
12:	9.3	→																																																																									
13:	9.6	↘																																																																									
14:	10.8x	↗																																																																									
15:	10.7x	↑																																																																									
16:	9.7	↗																																																																									
17:	9.9	↗																																																																									
18:	9.9	↗																																																																									
19:	10.2x	←																																																																									
20:	10.6x	↑																																																																									
Serie		100.5																																																																									
Total		198.5																																																																									
<p>60 Skott</p> 	<table border="1" style="width:100%; border-collapse: collapse;"> <tr><td>21:</td><td>9.7</td><td>↑</td></tr> <tr><td>22:</td><td>10.6x</td><td>↑</td></tr> <tr><td>23:</td><td>8.9</td><td>↑</td></tr> <tr><td>24:</td><td>10.5x</td><td>↘</td></tr> <tr><td>25:</td><td>10.7x</td><td>↘</td></tr> <tr><td>26:</td><td>10.0</td><td>↗</td></tr> <tr><td>27:</td><td>10.3x</td><td>↘</td></tr> <tr><td>28:</td><td>9.5</td><td>→</td></tr> <tr><td>29:</td><td>10.5x</td><td>↖</td></tr> <tr><td>30:</td><td>8.9</td><td>←</td></tr> <tr><td colspan="2">Serie</td><td>99.6</td></tr> <tr><td colspan="2">Total</td><td>298.1</td></tr> </table>	21:	9.7	↑	22:	10.6x	↑	23:	8.9	↑	24:	10.5x	↘	25:	10.7x	↘	26:	10.0	↗	27:	10.3x	↘	28:	9.5	→	29:	10.5x	↖	30:	8.9	←	Serie		99.6	Total		298.1	<p>60 Skott</p> 	<table border="1" style="width:100%; border-collapse: collapse;"> <tr><td>31:</td><td>10.8x</td><td>↘</td></tr> <tr><td>32:</td><td>10.1</td><td>↘</td></tr> <tr><td>33:</td><td>9.8</td><td>←</td></tr> <tr><td>34:</td><td>9.8</td><td>↘</td></tr> <tr><td>35:</td><td>10.6x</td><td>←</td></tr> <tr><td>36:</td><td>10.3x</td><td>↑</td></tr> <tr><td>37:</td><td>10.1</td><td>←</td></tr> <tr><td>38:</td><td>10.4x</td><td>↗</td></tr> <tr><td>39:</td><td>10.5x</td><td>↘</td></tr> <tr><td>40:</td><td>9.9</td><td>→</td></tr> <tr><td colspan="2">Serie</td><td>102.3</td></tr> <tr><td colspan="2">Total</td><td>400.4</td></tr> </table>	31:	10.8x	↘	32:	10.1	↘	33:	9.8	←	34:	9.8	↘	35:	10.6x	←	36:	10.3x	↑	37:	10.1	←	38:	10.4x	↗	39:	10.5x	↘	40:	9.9	→	Serie		102.3	Total		400.4
21:	9.7	↑																																																																									
22:	10.6x	↑																																																																									
23:	8.9	↑																																																																									
24:	10.5x	↘																																																																									
25:	10.7x	↘																																																																									
26:	10.0	↗																																																																									
27:	10.3x	↘																																																																									
28:	9.5	→																																																																									
29:	10.5x	↖																																																																									
30:	8.9	←																																																																									
Serie		99.6																																																																									
Total		298.1																																																																									
31:	10.8x	↘																																																																									
32:	10.1	↘																																																																									
33:	9.8	←																																																																									
34:	9.8	↘																																																																									
35:	10.6x	←																																																																									
36:	10.3x	↑																																																																									
37:	10.1	←																																																																									
38:	10.4x	↗																																																																									
39:	10.5x	↘																																																																									
40:	9.9	→																																																																									
Serie		102.3																																																																									
Total		400.4																																																																									
<p>60 Skott</p> 	<table border="1" style="width:100%; border-collapse: collapse;"> <tr><td>41:</td><td>9.5</td><td>↑</td></tr> <tr><td>42:</td><td>10.3x</td><td>↘</td></tr> <tr><td>43:</td><td>9.8</td><td>↘</td></tr> <tr><td>44:</td><td>9.5</td><td>↘</td></tr> <tr><td>45:</td><td>10.2x</td><td>↗</td></tr> <tr><td>46:</td><td>10.5x</td><td>↘</td></tr> <tr><td>47:</td><td>10.6x</td><td>↑</td></tr> <tr><td>48:</td><td>9.3</td><td>↘</td></tr> <tr><td>49:</td><td>9.9</td><td>↗</td></tr> <tr><td>50:</td><td>10.1</td><td>←</td></tr> <tr><td colspan="2">Serie</td><td>99.7</td></tr> <tr><td colspan="2">Total</td><td>500.1</td></tr> </table>	41:	9.5	↑	42:	10.3x	↘	43:	9.8	↘	44:	9.5	↘	45:	10.2x	↗	46:	10.5x	↘	47:	10.6x	↑	48:	9.3	↘	49:	9.9	↗	50:	10.1	←	Serie		99.7	Total		500.1	<p>60 Skott</p> 	<table border="1" style="width:100%; border-collapse: collapse;"> <tr><td>51:</td><td>10.4x</td><td>↘</td></tr> <tr><td>52:</td><td>9.3</td><td>↖</td></tr> <tr><td>53:</td><td>10.4x</td><td>↘</td></tr> <tr><td>54:</td><td>10.0</td><td>↘</td></tr> <tr><td>55:</td><td>9.2</td><td>↘</td></tr> <tr><td>56:</td><td>9.1</td><td>↗</td></tr> <tr><td>57:</td><td>9.5</td><td>↗</td></tr> <tr><td>58:</td><td>9.6</td><td>↘</td></tr> <tr><td>59:</td><td>9.1</td><td>←</td></tr> <tr><td>60:</td><td>10.2x</td><td>↘</td></tr> <tr><td colspan="2">Serie</td><td>96.8</td></tr> <tr><td colspan="2">Total</td><td>596.9</td></tr> </table>	51:	10.4x	↘	52:	9.3	↖	53:	10.4x	↘	54:	10.0	↘	55:	9.2	↘	56:	9.1	↗	57:	9.5	↗	58:	9.6	↘	59:	9.1	←	60:	10.2x	↘	Serie		96.8	Total		596.9
41:	9.5	↑																																																																									
42:	10.3x	↘																																																																									
43:	9.8	↘																																																																									
44:	9.5	↘																																																																									
45:	10.2x	↗																																																																									
46:	10.5x	↘																																																																									
47:	10.6x	↑																																																																									
48:	9.3	↘																																																																									
49:	9.9	↗																																																																									
50:	10.1	←																																																																									
Serie		99.7																																																																									
Total		500.1																																																																									
51:	10.4x	↘																																																																									
52:	9.3	↖																																																																									
53:	10.4x	↘																																																																									
54:	10.0	↘																																																																									
55:	9.2	↘																																																																									
56:	9.1	↗																																																																									
57:	9.5	↗																																																																									
58:	9.6	↘																																																																									
59:	9.1	←																																																																									
60:	10.2x	↘																																																																									
Serie		96.8																																																																									
Total		596.9																																																																									

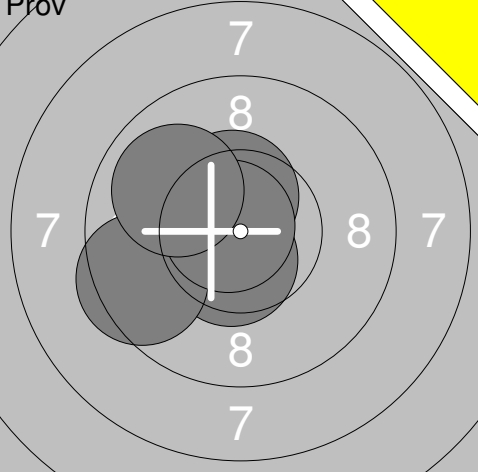
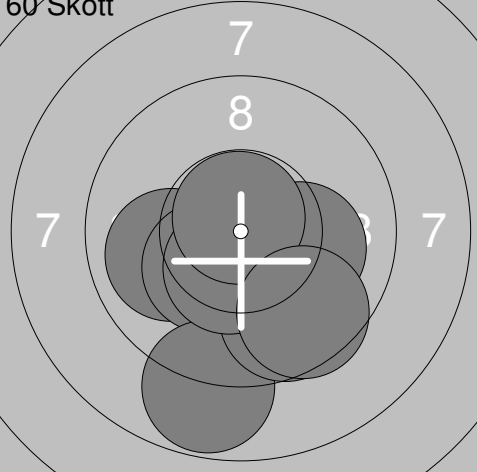
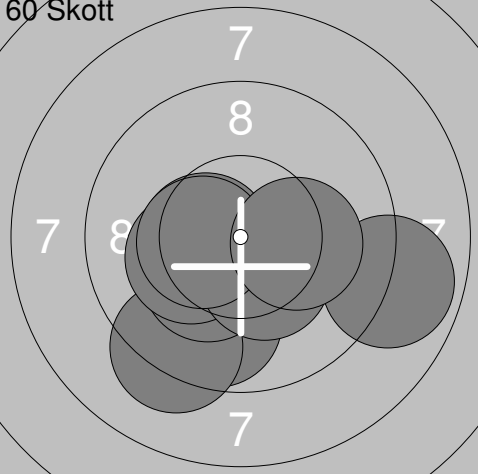
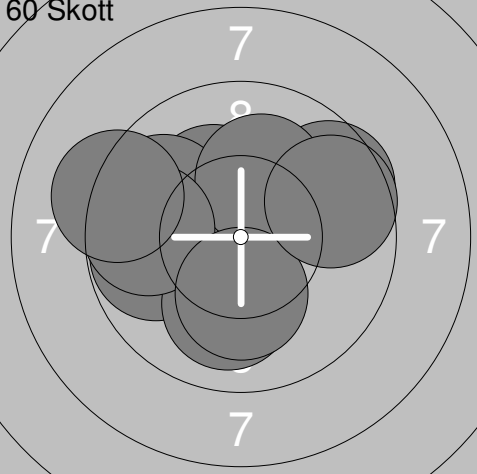
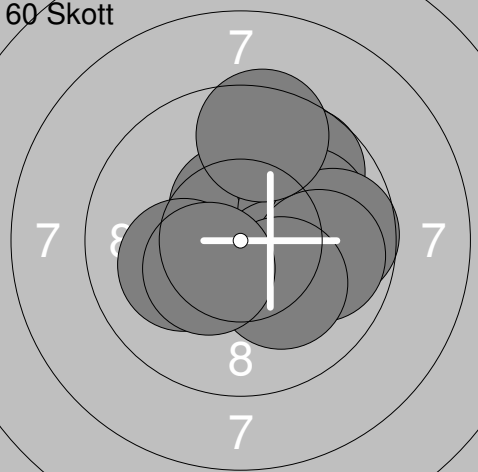
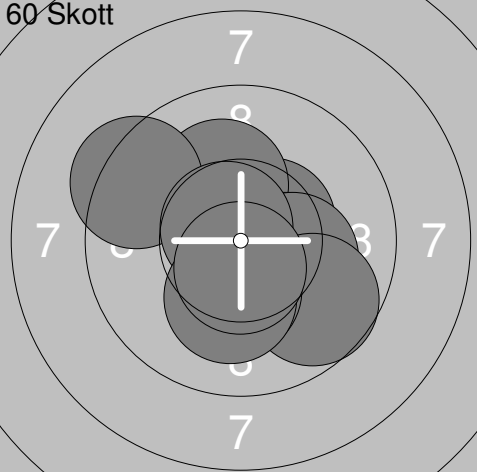
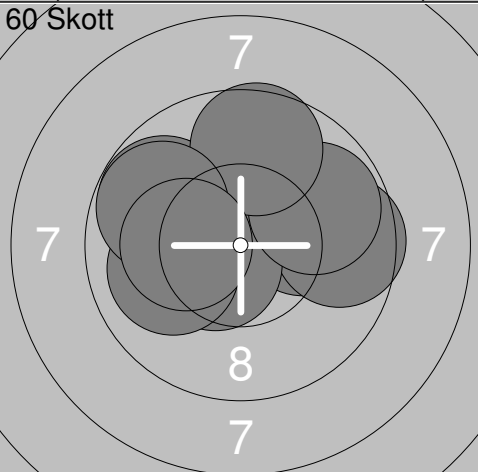
<p>Pröv</p> 	<p>1: 10.5x ↓ 2: 9.5 ← 3: 10.5x ↑ 4: 10.8x ↖ 5: 9.9 ↗</p> <p>Serie 51.2 Total 0.0</p>	<p>60 Skott</p>  <p>1: 10.7x ↓ 2: 10.0 ← 3: 10.2x ↓ 4: 10.3x ↓ 5: 10.1 → 6: 8.8 ↓ 7: 9.7 ↓ 8: 10.4x ↓ 9: 10.8x ↑ 10: 9.6 ↓</p> <p>Serie 100.6 Total 100.6</p>
<p>60 Skott</p> 	<p>11: 9.8 ↓ 12: 10.5x ↓ 13: 9.2 ↓ 14: 10.5x ← 15: 10.3x ↓ 16: 10.2x ← 17: 10.4x ↓ 18: 8.9 → 19: 10.4x ← 20: 10.2x →</p> <p>Serie 100.4 Total 201.0</p>	<p>60 Skott</p>  <p>21: 9.6 ↗ 22: 10.2x ↖ 23: 9.8 ← 24: 9.8 ↖ 25: 10.0 ↓ 26: 10.1 ↑ 27: 9.7 ← 28: 10.2x ↓ 29: 9.2 ↖ 30: 9.6 →</p> <p>Serie 98.2 Total 299.2</p>
<p>60 Skott</p> 	<p>31: 10.5x ↑ 32: 10.1 ← 33: 9.7 ↗ 34: 10.0 → 35: 10.3x ↓ 36: 9.7 → 37: 9.9 → 38: 10.2x ↓ 39: 9.5 ↑ 40: 10.4x ↙</p> <p>Serie 100.3 Total 399.5</p>	<p>60 Skott</p>  <p>41: 10.5x ↗ 42: 10.2x ↑ 43: 10.3x → 44: 10.2x → 45: 9.7 ↓ 46: 10.3x ↓ 47: 9.3 ↗ 48: 10.7x ↗ 49: 10.2x ↓ 50: 10.6x ↓</p> <p>Serie 102.0 Total 501.5</p>
<p>60 Skott</p> 	<p>51: 10.1 → 52: 9.9 ↗ 53: 9.6 → 54: 10.5x ↙ 55: 9.8 ↖ 56: 10.0 ← 57: 9.8 → 58: 9.6 ↑ 59: 9.8 ↖ 60: 10.2x ←</p> <p>Serie 99.3 Total 600.8</p>	

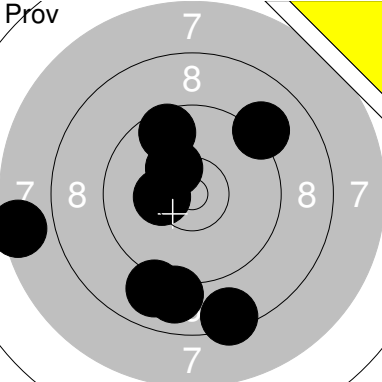
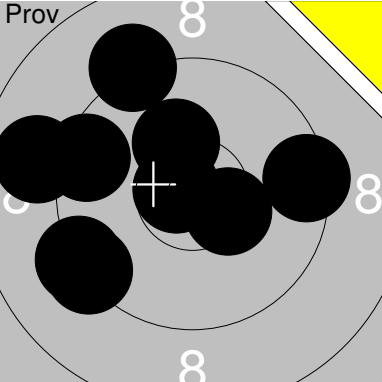
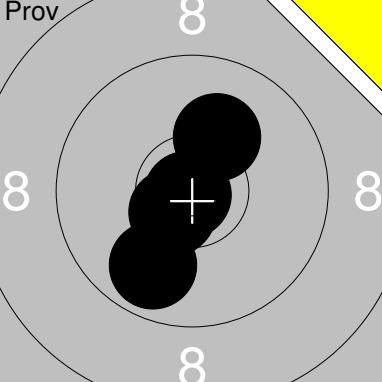
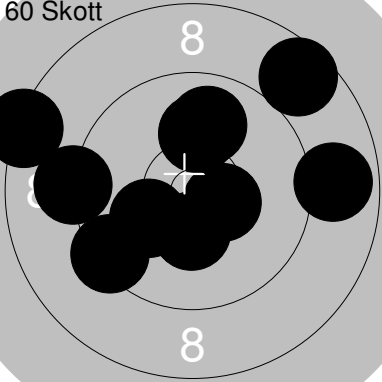
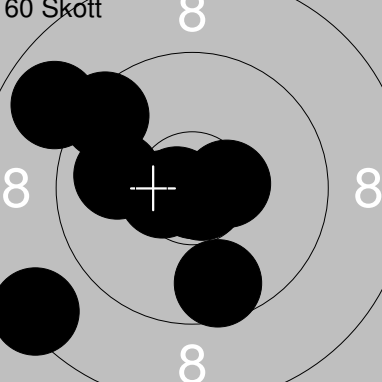
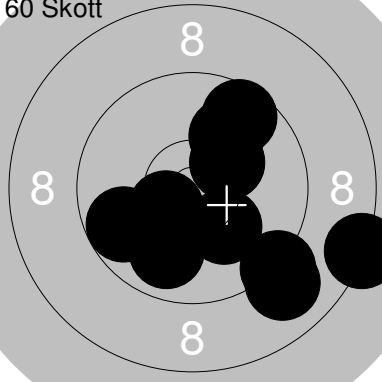
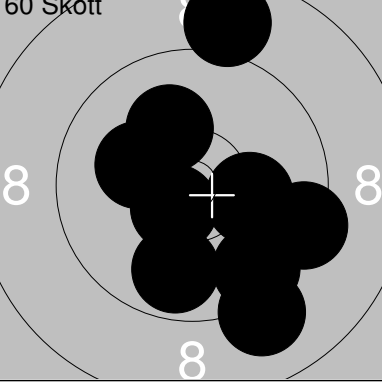
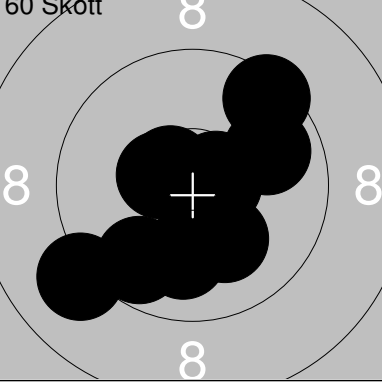
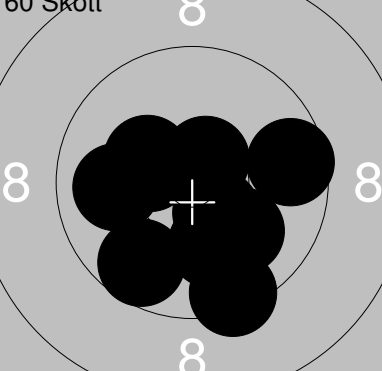
Skjutlag 3	Tavla 25	Roger Gustavsson	
S		Team Träffpunkten Lidköping	
08.04.2017		UMEKULAN 2017	Umeå skytteallians
	1: 7.5 ← 2: 8.5 ↓ 3: 9.0 ↓ 4: 10.4x ← 5: 9.1 ↗ 8: 9.0 ↓ 9: 10.3 ↗ 10: 9.7 ↗		11: 9.5 → 12: 9.5 ↖ 13: 10.7x ↖ 14: 9.2 ↗ 15: 10.3 ↗ 16: 10.4x → 18: 8.9 ← 19: 9.3 ↓ 20: 9.3 ↓
Serie 73.5		Serie 87.1	
Total 0.0		Total 0.0	
	21: 9.9 ↓ 22: 10.6x ↓ 23: 10.2 ↗ 24: 10.9x ↓		1: 10.4x ↓ 2: 9.2 ← 3: 8.3 ↖ 4: 9.4 ↖ 5: 10.0 ↗ 6: 10.1 ↗ 7: 10.5x → 8: 8.7 ↗ 9: 8.9 → 10: 10.2 ↖
Serie 41.6		Serie 95.7	
Total 0.0		Total 95.7	
	11: 10.9x ↓ 12: 9.5 ↗ 13: 8.9 ↗ 14: 8.4 ↖ 15: 10.5x → 16: 10.8x ↓ 17: 9.7 ↓ 18: 10.6x ← 19: 10.0 ← 20: 10.8x ←		21: 9.8 ↖ 22: 9.7 ↗ 23: 10.2 ↓ 24: 10.0 ↗ 25: 9.9 ↓ 26: 9.2 ↓ 27: 10.5x ↖ 28: 10.3 ↗ 29: 9.0 ↓ 30: 8.3 →
Serie 100.1		Serie 96.9	
Total 195.8		Total 292.7	
	31: 9.6 ↓ 32: 8.9 ↗ 33: 10.6x ↓ 34: 10.2 → 35: 10.2 ↖ 36: 10.2 ↗ 37: 10.2 → 38: 9.9 ↓ 39: 9.1 ↓ 40: 9.4 ↓		41: 10.1 ↓ 42: 9.5 ↗ 43: 10.6x → 44: 10.5x ↖ 45: 9.8 ↓ 46: 10.6x ↗ 47: 9.9 → 48: 9.1 ↖ 49: 10.2 ↓ 50: 10.6x ↖
Serie 98.3		Serie 100.9	
Total 391.0		Total 491.9	
	51: 10.1 ↓ 52: 10.1 ↓ 53: 10.4x ↗ 54: 10.5x ↓ 55: 10.0 ← 56: 10.3 ↗ 57: 9.7 → 58: 9.5 ↓ 59: 10.6x ↗ 60: 9.8 ↓		
Serie 101.0			
Total 592.9			

	<table border="1" style="width:100%; border-collapse: collapse;"> <tr><td>1:</td><td>8.9</td><td>←</td></tr> <tr><td>2:</td><td>8.6</td><td>↑</td></tr> <tr><td>3:</td><td>9.5</td><td>↗</td></tr> <tr><td>4:</td><td>10.9x</td><td>←</td></tr> <tr><td>5:</td><td>10.1</td><td>↑</td></tr> <tr><td>6:</td><td>7.5</td><td>↗</td></tr> <tr><td>7:</td><td>9.9</td><td>→</td></tr> <tr><td>8:</td><td>9.2</td><td>↑</td></tr> <tr><td>9:</td><td>10.3</td><td>↘</td></tr> <tr><td>10:</td><td>9.4</td><td>←</td></tr> <tr><td colspan="2">Serie</td><td>94.3</td></tr> <tr><td colspan="2">Total</td><td>0.0</td></tr> </table>	1:	8.9	←	2:	8.6	↑	3:	9.5	↗	4:	10.9x	←	5:	10.1	↑	6:	7.5	↗	7:	9.9	→	8:	9.2	↑	9:	10.3	↘	10:	9.4	←	Serie		94.3	Total		0.0		<table border="1" style="width:100%; border-collapse: collapse;"> <tr><td>11:</td><td>10.0</td><td>↑</td></tr> <tr><td>12:</td><td>9.4</td><td>↗</td></tr> <tr><td>13:</td><td>9.4</td><td>↑</td></tr> <tr><td>15:</td><td>10.3</td><td>→</td></tr> <tr><td>16:</td><td>9.2</td><td>↓</td></tr> <tr><td>17:</td><td>10.6x</td><td>↓</td></tr> <tr><td colspan="2">Serie</td><td>58.9</td></tr> <tr><td colspan="2">Total</td><td>0.0</td></tr> </table>	11:	10.0	↑	12:	9.4	↗	13:	9.4	↑	15:	10.3	→	16:	9.2	↓	17:	10.6x	↓	Serie		58.9	Total		0.0
1:	8.9	←																																																													
2:	8.6	↑																																																													
3:	9.5	↗																																																													
4:	10.9x	←																																																													
5:	10.1	↑																																																													
6:	7.5	↗																																																													
7:	9.9	→																																																													
8:	9.2	↑																																																													
9:	10.3	↘																																																													
10:	9.4	←																																																													
Serie		94.3																																																													
Total		0.0																																																													
11:	10.0	↑																																																													
12:	9.4	↗																																																													
13:	9.4	↑																																																													
15:	10.3	→																																																													
16:	9.2	↓																																																													
17:	10.6x	↓																																																													
Serie		58.9																																																													
Total		0.0																																																													

	<table border="1" style="width:100%; border-collapse: collapse;"> <tr><td>1:</td><td>9.7</td><td>←</td></tr> <tr><td>2:</td><td>9.6</td><td>↘</td></tr> <tr><td>3:</td><td>9.2</td><td>↗</td></tr> <tr><td>4:</td><td>8.8</td><td>↗</td></tr> <tr><td>5:</td><td>10.0</td><td>↑</td></tr> <tr><td>6:</td><td>10.1</td><td>↑</td></tr> <tr><td>7:</td><td>10.6x</td><td>↑</td></tr> <tr><td>8:</td><td>9.8</td><td>↑</td></tr> <tr><td>9:</td><td>9.2</td><td>↗</td></tr> <tr><td>10:</td><td>8.2</td><td>↗</td></tr> <tr><td colspan="2">Serie</td><td>95.2</td></tr> <tr><td colspan="2">Total</td><td>95.2</td></tr> </table>	1:	9.7	←	2:	9.6	↘	3:	9.2	↗	4:	8.8	↗	5:	10.0	↑	6:	10.1	↑	7:	10.6x	↑	8:	9.8	↑	9:	9.2	↗	10:	8.2	↗	Serie		95.2	Total		95.2		<table border="1" style="width:100%; border-collapse: collapse;"> <tr><td>11:</td><td>9.0</td><td>←</td></tr> <tr><td>12:</td><td>8.7</td><td>↗</td></tr> <tr><td>13:</td><td>10.0</td><td>→</td></tr> <tr><td>14:</td><td>10.6x</td><td>↑</td></tr> <tr><td>15:</td><td>10.2</td><td>→</td></tr> <tr><td>16:</td><td>10.2</td><td>↗</td></tr> <tr><td>17:</td><td>9.8</td><td>→</td></tr> <tr><td>18:</td><td>6.2</td><td>→</td></tr> <tr><td>19:</td><td>8.8</td><td>↓</td></tr> <tr><td>20:</td><td>9.5</td><td>↗</td></tr> <tr><td colspan="2">Serie</td><td>93.0</td></tr> <tr><td colspan="2">Total</td><td>188.2</td></tr> </table>	11:	9.0	←	12:	8.7	↗	13:	10.0	→	14:	10.6x	↑	15:	10.2	→	16:	10.2	↗	17:	9.8	→	18:	6.2	→	19:	8.8	↓	20:	9.5	↗	Serie		93.0	Total		188.2
1:	9.7	←																																																																									
2:	9.6	↘																																																																									
3:	9.2	↗																																																																									
4:	8.8	↗																																																																									
5:	10.0	↑																																																																									
6:	10.1	↑																																																																									
7:	10.6x	↑																																																																									
8:	9.8	↑																																																																									
9:	9.2	↗																																																																									
10:	8.2	↗																																																																									
Serie		95.2																																																																									
Total		95.2																																																																									
11:	9.0	←																																																																									
12:	8.7	↗																																																																									
13:	10.0	→																																																																									
14:	10.6x	↑																																																																									
15:	10.2	→																																																																									
16:	10.2	↗																																																																									
17:	9.8	→																																																																									
18:	6.2	→																																																																									
19:	8.8	↓																																																																									
20:	9.5	↗																																																																									
Serie		93.0																																																																									
Total		188.2																																																																									

	<table border="1" style="width:100%; border-collapse: collapse;"> <tr><td>21:</td><td>9.5</td><td>↗</td></tr> <tr><td>22:</td><td>9.6</td><td>→</td></tr> <tr><td>23:</td><td>9.7</td><td>↗</td></tr> <tr><td>24:</td><td>9.0</td><td>↗</td></tr> <tr><td>25:</td><td>10.3</td><td>↗</td></tr> <tr><td>26:</td><td>10.0</td><td>↗</td></tr> <tr><td>27:</td><td>10.2</td><td>←</td></tr> <tr><td>28:</td><td>9.5</td><td>↗</td></tr> <tr><td>29:</td><td>9.1</td><td>→</td></tr> <tr><td>30:</td><td>9.4</td><td>↓</td></tr> <tr><td colspan="2">Serie</td><td>96.3</td></tr> <tr><td colspan="2">Total</td><td>284.5</td></tr> </table>	21:	9.5	↗	22:	9.6	→	23:	9.7	↗	24:	9.0	↗	25:	10.3	↗	26:	10.0	↗	27:	10.2	←	28:	9.5	↗	29:	9.1	→	30:	9.4	↓	Serie		96.3	Total		284.5		<table border="1" style="width:100%; border-collapse: collapse;"> <tr><td>31:</td><td>9.9</td><td>↗</td></tr> <tr><td>32:</td><td>9.5</td><td>↓</td></tr> <tr><td>33:</td><td>10.0</td><td>↑</td></tr> <tr><td>34:</td><td>9.9</td><td>↗</td></tr> <tr><td>35:</td><td>10.1</td><td>↑</td></tr> <tr><td>36:</td><td>9.1</td><td>↖</td></tr> <tr><td>37:</td><td>10.1</td><td>↖</td></tr> <tr><td>38:</td><td>10.8x</td><td>↓</td></tr> <tr><td>39:</td><td>10.3</td><td>←</td></tr> <tr><td>40:</td><td>8.3</td><td>↓</td></tr> <tr><td colspan="2">Serie</td><td>98.0</td></tr> <tr><td colspan="2">Total</td><td>382.5</td></tr> </table>	31:	9.9	↗	32:	9.5	↓	33:	10.0	↑	34:	9.9	↗	35:	10.1	↑	36:	9.1	↖	37:	10.1	↖	38:	10.8x	↓	39:	10.3	←	40:	8.3	↓	Serie		98.0	Total		382.5
21:	9.5	↗																																																																									
22:	9.6	→																																																																									
23:	9.7	↗																																																																									
24:	9.0	↗																																																																									
25:	10.3	↗																																																																									
26:	10.0	↗																																																																									
27:	10.2	←																																																																									
28:	9.5	↗																																																																									
29:	9.1	→																																																																									
30:	9.4	↓																																																																									
Serie		96.3																																																																									
Total		284.5																																																																									
31:	9.9	↗																																																																									
32:	9.5	↓																																																																									
33:	10.0	↑																																																																									
34:	9.9	↗																																																																									
35:	10.1	↑																																																																									
36:	9.1	↖																																																																									
37:	10.1	↖																																																																									
38:	10.8x	↓																																																																									
39:	10.3	←																																																																									
40:	8.3	↓																																																																									
Serie		98.0																																																																									
Total		382.5																																																																									

	<table border="1" style="width:100%; border-collapse: collapse;"> <tr><td>41:</td><td>10.3</td><td>↑</td></tr> <tr><td>42:</td><td>9.6</td><td>↖</td></tr> <tr><td>43:</td><td>10.1</td><td>↑</td></tr> <tr><td>44:</td><td>9.6</td><td>↗</td></tr> <tr><td>45:</td><td>10.0</td><td>→</td></tr> <tr><td>46:</td><td>9.3</td><td>←</td></tr> <tr><td>47:</td><td>9.3</td><td>↓</td></tr> <tr><td>48:</td><td>9.6</td><td>↗</td></tr> <tr><td>49:</td><td>10.0</td><td>↓</td></tr> <tr><td>50:</td><td>10.2</td><td>↗</td></tr> <tr><td colspan="2">Serie</td><td>98.0</td></tr> <tr><td colspan="2">Total</td><td>480.5</td></tr> </table>	41:	10.3	↑	42:	9.6	↖	43:	10.1	↑	44:	9.6	↗	45:	10.0	→	46:	9.3	←	47:	9.3	↓	48:	9.6	↗	49:	10.0	↓	50:	10.2	↗	Serie		98.0	Total		480.5		<table border="1" style="width:100%; border-collapse: collapse;"> <tr><td>51:</td><td>8.5</td><td>↓</td></tr> <tr><td>52:</td><td>9.1</td><td>←</td></tr> <tr><td>53:</td><td>9.5</td><td>↗</td></tr> <tr><td>54:</td><td>10.1</td><td>↗</td></tr> <tr><td>55:</td><td>9.7</td><td>↗</td></tr> <tr><td>56:</td><td>10.7x</td><td>↗</td></tr> <tr><td>57:</td><td>10.3</td><td>↑</td></tr> <tr><td>58:</td><td>9.8</td><td>←</td></tr> <tr><td>59:</td><td>8.7</td><td>→</td></tr> <tr><td>60:</td><td>10.7x</td><td>↖</td></tr> <tr><td colspan="2">Serie</td><td>97.1</td></tr> <tr><td colspan="2">Total</td><td>577.6</td></tr> </table>	51:	8.5	↓	52:	9.1	←	53:	9.5	↗	54:	10.1	↗	55:	9.7	↗	56:	10.7x	↗	57:	10.3	↑	58:	9.8	←	59:	8.7	→	60:	10.7x	↖	Serie		97.1	Total		577.6
41:	10.3	↑																																																																									
42:	9.6	↖																																																																									
43:	10.1	↑																																																																									
44:	9.6	↗																																																																									
45:	10.0	→																																																																									
46:	9.3	←																																																																									
47:	9.3	↓																																																																									
48:	9.6	↗																																																																									
49:	10.0	↓																																																																									
50:	10.2	↗																																																																									
Serie		98.0																																																																									
Total		480.5																																																																									
51:	8.5	↓																																																																									
52:	9.1	←																																																																									
53:	9.5	↗																																																																									
54:	10.1	↗																																																																									
55:	9.7	↗																																																																									
56:	10.7x	↗																																																																									
57:	10.3	↑																																																																									
58:	9.8	←																																																																									
59:	8.7	→																																																																									
60:	10.7x	↖																																																																									
Serie		97.1																																																																									
Total		577.6																																																																									

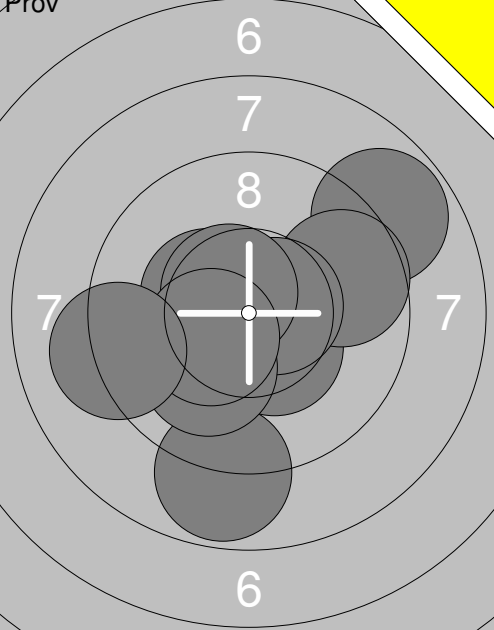
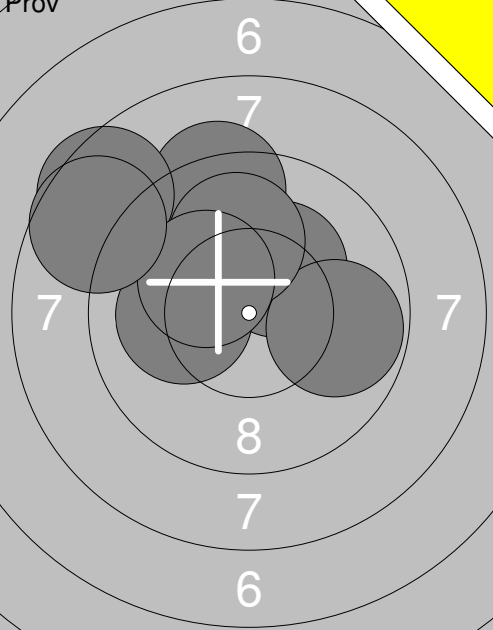
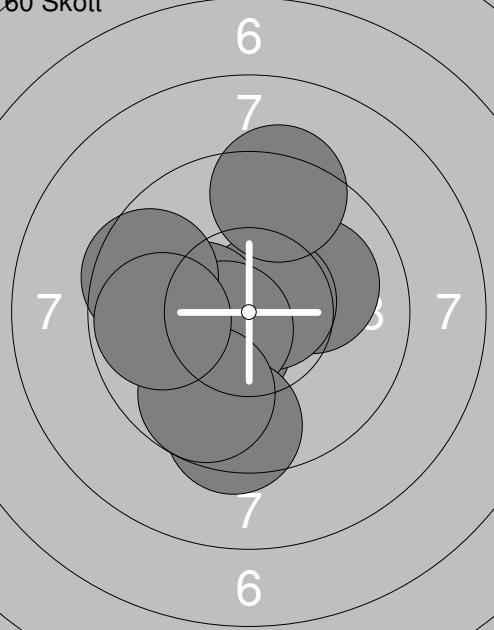
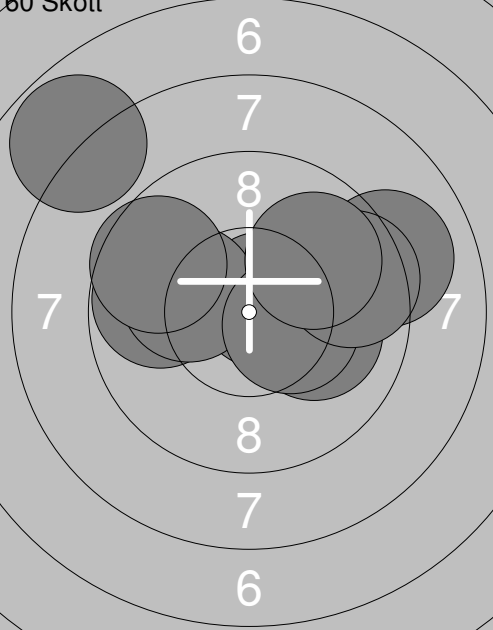
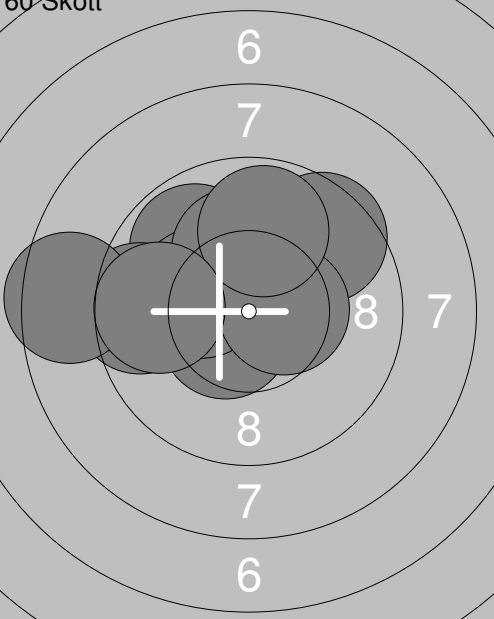
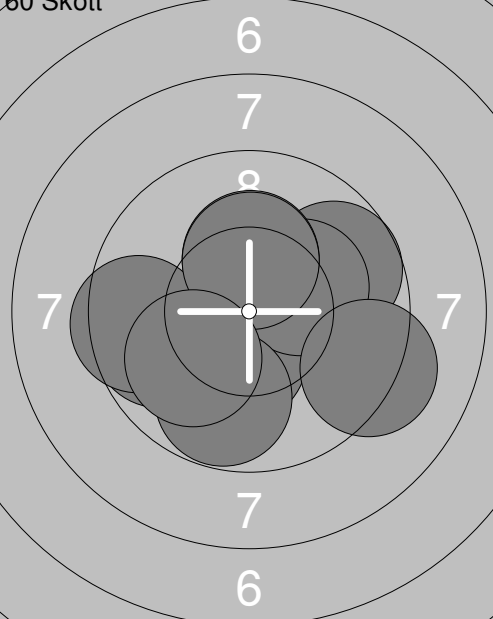
 <p>Provschott</p>	<p>1: 10.4 ↘</p> <p>2: 8.8 →</p> <p>3: 10.4 ↘</p> <p>4: 9.7 →</p> <p>5: 10.6x →</p> <p>6: 8.8 ↓</p> <p>7: 10.1 ↘</p> <p>8: 10.6x ↘</p> <p>9: 10.4x ↘</p> <p>10: 9.2 ←</p> <p>Serie 99.0</p> <p>Total 0.0</p>	 <p>Provschott</p>	<p>11: 10.1 ↘</p> <p>12: 10.3x ↗</p> <p>13: 10.1 ↘</p> <p>14: 9.3 ↑</p> <p>15: 9.8 →</p> <p>16: 8.5 ↘</p> <p>17: 10.1 ←</p> <p>18: 10.0 ↑</p> <p>19: 10.2x ↘</p> <p>20: 8.7 ↘</p> <p>Serie 97.1</p> <p>Total 0.0</p>
 <p>60 Skott</p>	<p>1: 10.1 →</p> <p>2: 10.4x ↘</p> <p>3: 10.7x ↗</p> <p>4: 10.3x ←</p> <p>5: 9.4 ↑</p> <p>6: 10.6x ↘</p> <p>7: 9.6 ←</p> <p>8: 9.5 ↓</p> <p>9: 9.8 ↘</p> <p>10: 9.8 ←</p> <p>Serie 100.2</p> <p>Total 100.2</p>	 <p>60 Skott</p>	<p>11: 9.8 ←</p> <p>12: 9.0 →</p> <p>13: 10.7x ↗</p> <p>14: 10.1 ←</p> <p>15: 10.1 →</p> <p>16: 10.4x →</p> <p>17: 9.5 →</p> <p>18: 9.6 ←</p> <p>19: 7.8 ↘</p> <p>20: 9.9 ↗</p> <p>Serie 96.9</p> <p>Total 197.1</p>
 <p>60 Skott</p>	<p>21: 9.8 ↘</p> <p>22: 9.5 ←</p> <p>23: 9.5 ↗</p> <p>24: 10.5x ↘</p> <p>25: 10.3x ↘</p> <p>26: 8.5 ←</p> <p>27: 10.1 ↑</p> <p>28: 10.5x →</p> <p>29: 9.8 ↑</p> <p>30: 9.7 ←</p> <p>Serie 98.2</p> <p>Total 295.3</p>	 <p>60 Skott</p>	<p>31: 9.7 →</p> <p>32: 10.4x ↘</p> <p>33: 10.2x ↗</p> <p>34: 10.3x ↑</p> <p>35: 9.2 →</p> <p>36: 9.7 ←</p> <p>37: 9.5 ←</p> <p>38: 10.3x ↑</p> <p>39: 9.8 ↓</p> <p>40: 10.0 ↘</p> <p>Serie 99.1</p> <p>Total 394.4</p>

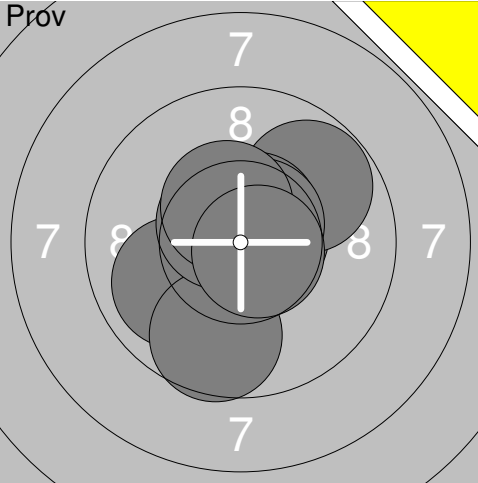
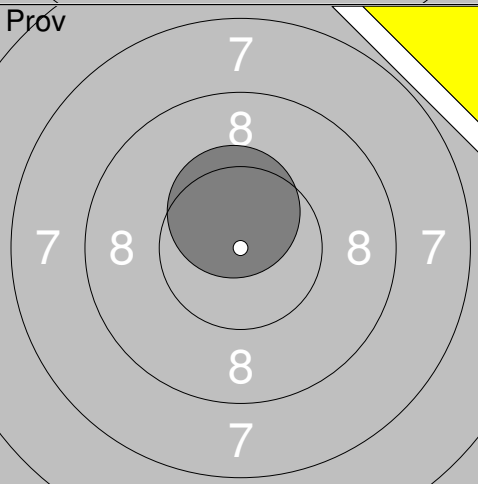
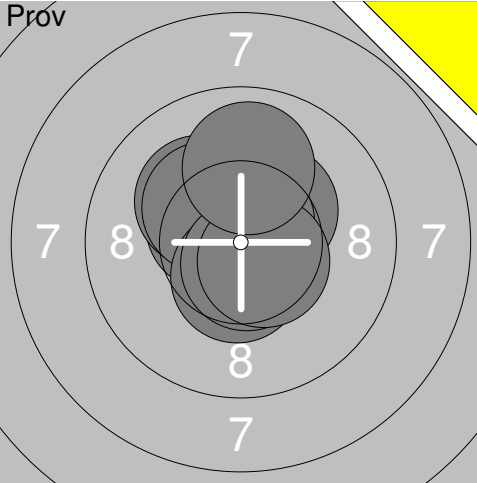
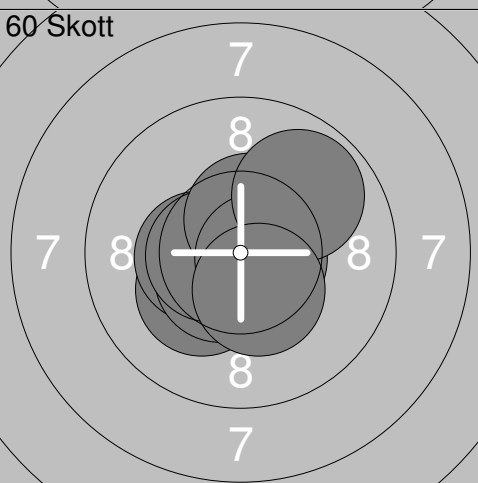
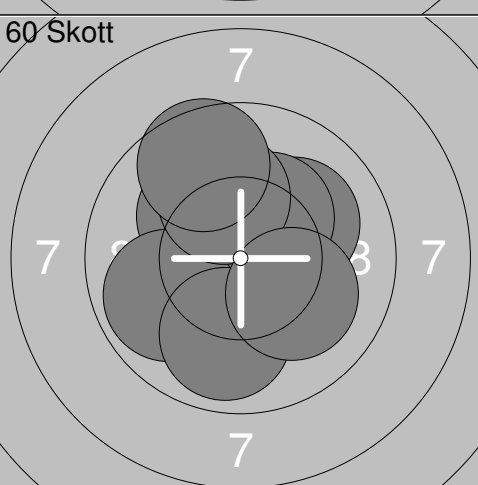
Skjutlag	Tavla	Kevin Calla	
3	33		
S	Gideå Skf		
08.04.2017	UMEKULAN 2017	Umeå skytteallians	
Prov		1: 9.9 ↙ 2: 9.7 ↓ 4: 10.6x ↗ 5: 10.6x → 6: 9.8 ↗ 7: 10.6x ↗ 8: 10.6x ↗ 9: 10.4x ↗ 10: 10.7x ↘	11: 10.3x ↗ 12: 10.8x ↑ 13: 10.5x ↗ 14: 10.2x ↗ 15: 10.7x ↗ 16: 10.3x ↗ 17: 10.5x ↓ 18: 10.6x ↓ 19: 10.6x ↘ 20: 9.9 ↑
		Serie 92.9	Serie 104.4
		Total 0.0	Total 0.0
Prov		21: 10.5x ↑	
		Serie 10.5	
		Total 0.0	
60 Skott			1: 10.6x ↓ 2: 10.4x → 3: 10.1 ↓ 4: 10.0 ↓ 5: 10.5x ↗ 6: 10.5x ↗ 7: 10.3x ↓ 8: 10.4x → 9: 10.6x ↙ 10: 10.8x ↙
		Serie 104.2	Serie 104.2
		Total 104.2	Total 104.2
60 Skott		11: 10.2x ↙ 12: 10.6x ↙ 13: 10.4x ← 14: 10.7x ↑ 15: 10.5x ↙ 16: 10.6x ← 17: 10.5x ↑ 18: 10.7x → 19: 9.9 ↗ 20: 10.4x ↓	21: 9.8 → 22: 9.8 ↑ 23: 10.6x → 24: 10.7x ↑ 25: 9.9 ↙ 26: 10.7x → 27: 10.6x ↗ 28: 10.4x ↗ 29: 10.7x ↘ 30: 10.7x ↓
		Serie 104.5	Serie 103.9
		Total 208.7	Total 312.6
60 Skott		31: 10.1 ↗ 32: 10.4x ↗ 33: 10.7x ↗ 34: 10.3x ↗ 35: 10.2x ↗ 36: 9.9 ↙ 37: 10.1 ↗ 38: 9.6 ↗ 39: 9.9 ↓ 40: 10.1 ↘	
		Serie 101.3	
		Total 413.9	

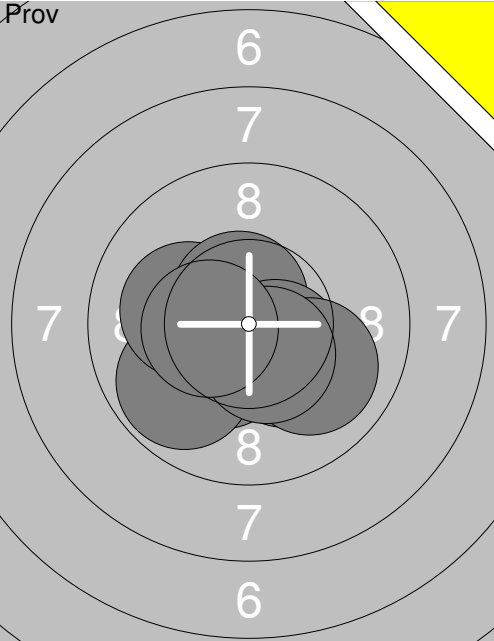
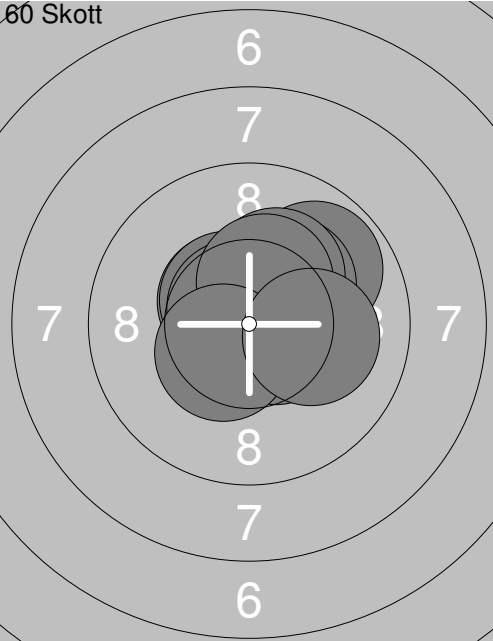
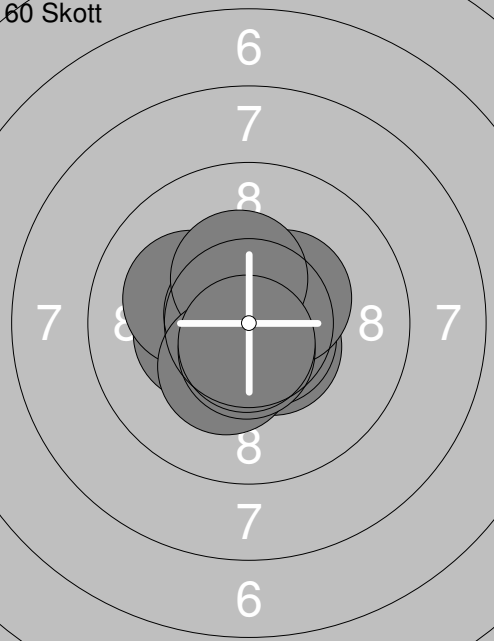
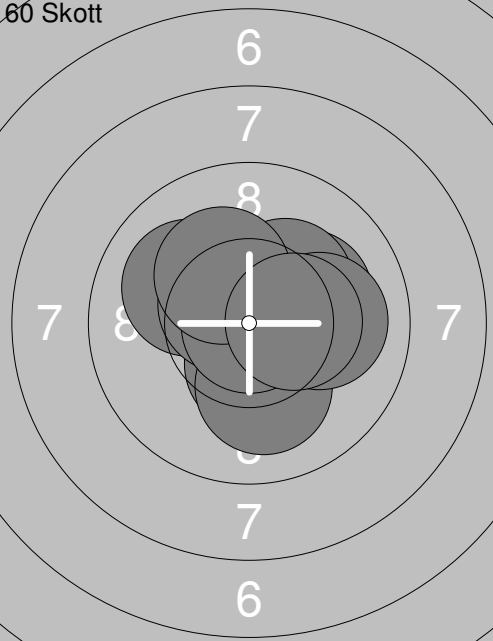
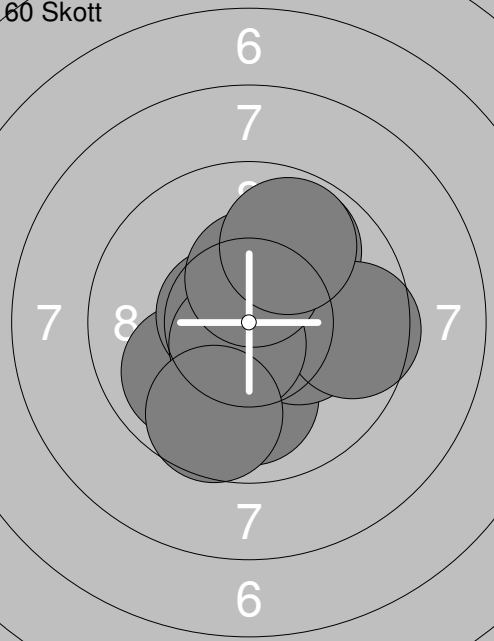
Skjutlag 3	Tavla 34	Lennart Westermark	
S		Drängsmarks Skf	
08.04.2017		UMEKULAN 2017	Umeå skytteallians
	1: 10.4x ↘ 2: 9.8 ↙ 3: 10.1 ← 4: 10.6x ↗ 5: 10.3x ↘ 6: 10.5x ↘ 7: 10.0 ↘ 8: 10.5x ↘ 9: 10.5x ↘ 10: 10.4x ←		1: 10.6x ↘ 2: 10.5x ↘ 3: 9.8 ↗ 4: 10.2x ↗ 5: 10.5x ↘ 6: 10.7x ↘ 7: 10.2x ↗ 8: 10.4x ↗ 9: 10.4x ↘ 10: 10.1 →
Serie 92.6		Serie 103.4	
Total 0.0		Total 103.4	
	11: 10.5x ↘ 12: 10.3x ← 13: 10.1 ← 14: 10.6x ↘ 15: 10.7x ↘ 16: 10.4x ↗ 17: 10.3x ↗ 18: 10.3x ↘ 19: 10.6x ↘ 20: 10.7x ↘		21: 10.4x ↘ 22: 10.1 ↓ 23: 10.0 ← 24: 10.6x ↘ 25: 10.9x ↘ 26: 10.2x ↗ 27: 10.3x ↗ 28: 10.0 → 29: 10.2x ↘ 30: 10.4x →
Serie 104.5		Serie 103.1	
Total 207.9		Total 311.0	
	31: 10.0 ↓ 32: 10.0 ↙ 33: 10.6x ↘ 34: 10.3x → 35: 9.9 ↗ 36: 9.6 → 37: 10.6x ↘ 38: 10.4x ↗ 39: 9.8 ↗ 40: 9.7 ↓		
Serie 100.9			
Total 411.9			

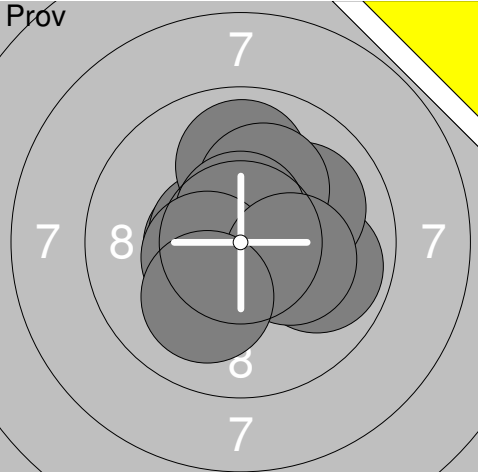
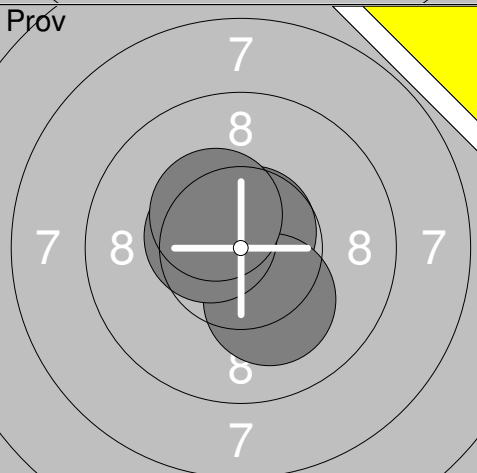
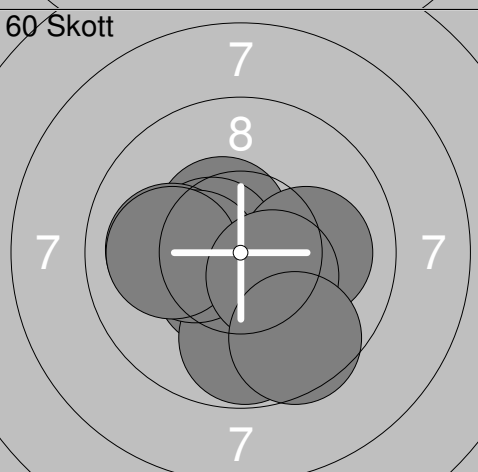
Skjutlag	Tavla	Rebecka Bäckman	
3	35		
S	Gideå Skf		
08.04.2017	UMEKULAN 2017	Umeå skytteallians	
Prov 	1: 10.5x ←	Prov 	11: 10.0 ←
	2: 9.9 →		12: 10.6x ↙
	3: 10.6x ↖		13: 10.6x ↗
	4: 10.0 →		14: 10.8x ↘
	5: 9.9 ↑		16: 9.5 ↙
	6: 10.2x ↗		18: 10.2x ↖
	7: 10.6x ↑		19: 9.5 ↗
	8: 10.5x ←		20: 10.4x ↗
	9: 10.2x →		
	10: 10.1 ↓		
Serie	102.5	Serie	81.6
Total	0.0	Total	0.0
Prov 	21: 10.3x ←	Prov 	31: 10.5x ↗
	22: 10.6x ↓		32: 10.7x ↗
	23: 10.8x ↘		33: 10.2x ↘
	24: 10.3x ↗		34: 10.5x ↗
	25: 10.5x ↗		35: 10.4x ↗
	26: 10.2x ↗		
	27: 10.6x ↘		
	28: 10.1 ↓		
	29: 10.3x →		
	30: 10.5x ↘		
Serie	104.2	Serie	52.3
Total	0.0	Total	0.0
60 Skott 	1: 10.5x ↗	60 Skott 	11: 10.4x →
	2: 10.5x ←		12: 9.9 ↘
	3: 10.0 ←		13: 10.3x ↗
	4: 10.5x ↘		14: 10.6x →
	5: 9.8 ↓		15: 10.5x ↘
	6: 10.3x ←		16: 10.7x ↗
	7: 10.0 ←		17: 10.6x ↖
	8: 10.1 →		18: 10.5x ↑
	9: 10.4x ↘		19: 9.7 →
	10: 9.6 ↘		20: 10.6x ↘
Serie	101.7	Serie	103.8
Total	101.7	Total	205.5
60 Skott 	21: 10.3x ↘	60 Skott 	31: 10.6x ↗
	22: 10.6x ↑		32: 10.1 ↑
	23: 10.3x ↘		33: 10.6x ↘
	24: 10.0 ↓		34: 10.7x ↗
	25: 10.2x ↘		35: 10.5x ↗
	26: 9.3 →		36: 10.5x ↙
	27: 10.5x →		37: 10.6x ↘
	28: 10.2x ↘		38: 10.8x ↗
	29: 10.0 ↘		39: 10.6x ↗
	30: 10.7x ↓		40: 10.5x ↘
Serie	102.1	Serie	105.5
Total	307.6	Total	413.1

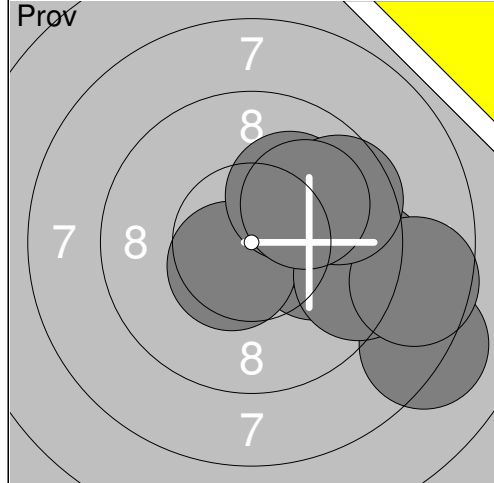

1:	8.2	↘
2:	9.3	→
3:	10.0	→
4:	10.0	→
5:	10.5x	↙
6:	9.4	→
7:	10.1	↗
8:	8.6	→
9:	9.6	→
10:	10.0	↗
Serie	95.7	
Total	0.0	

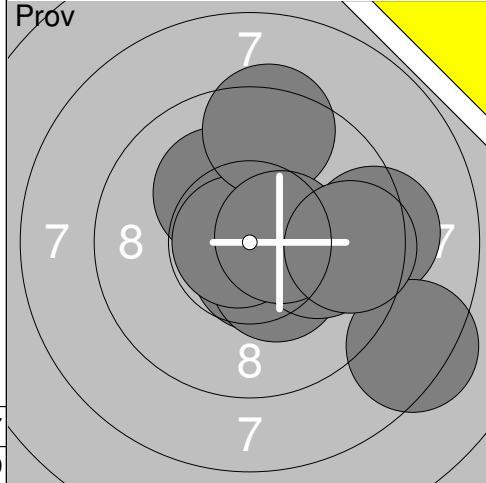

11:	10.6x	↘
12:	9.3	→
13:	10.2x	↗
14:	10.4x	↘
15:	10.8x	←
16:	10.0	→
17:	9.4	↑
18:	10.5x	→
19:	8.4	↘
20:	9.6	→
Serie	99.2	
Total	0.0	

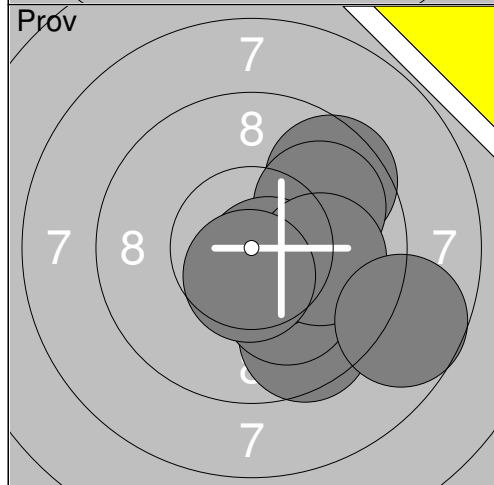

21:	9.6	↘
22:	9.6	↗
23:	10.6x	↘
24:	9.9	→
25:	10.1	↘
26:	10.6x	↘
27:	10.0	→
28:	8.7	↘
29:	10.6x	↓
Serie	89.7	
Total	0.0	

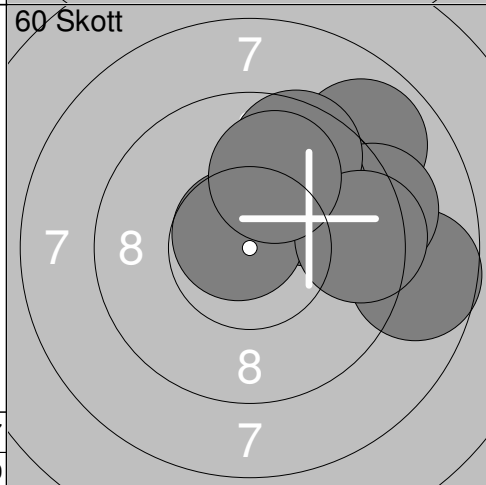

1:	8.9	↗
2:	9.7	↗
3:	9.9	↗
4:	8.7	→
5:	9.2	→
6:	9.9	↗
7:	10.7x	↖
8:	9.6	↑
9:	9.4	→
10:	9.9	↑
Serie	95.9	
Total	95.9	

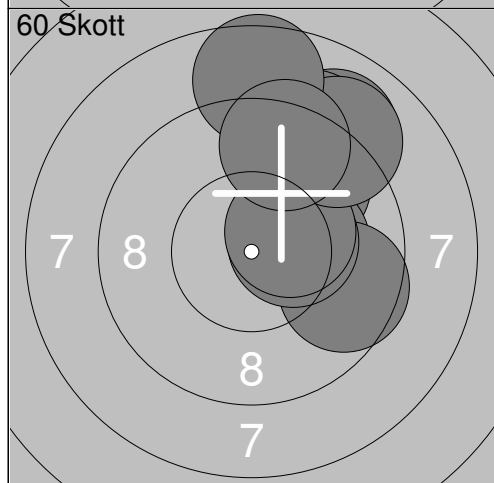

11:	9.8	↗
12:	10.2x	→
13:	9.6	↘
14:	9.0	↗
15:	10.4x	→
16:	9.2	↑
17:	10.4x	↗
18:	9.0	↗
19:	8.6	↑
20:	9.4	↑
Serie	95.6	
Total	191.5	

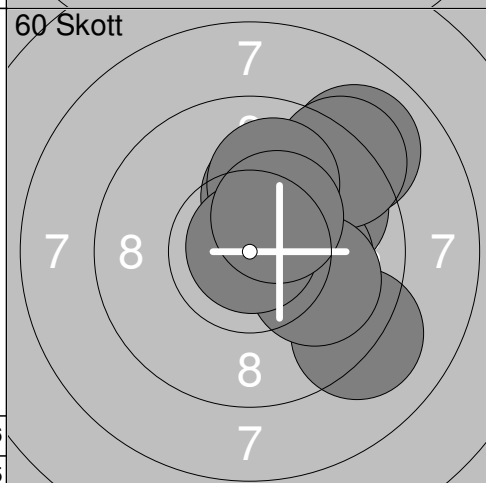

21:	9.8	↗
22:	10.2x	↑
23:	9.1	↘
24:	10.2x	→
25:	9.0	↗
26:	9.2	↗
27:	10.0	↑
28:	10.0	→
29:	10.9x	↑
30:	10.4x	↗
Serie	98.8	
Total	290.3	

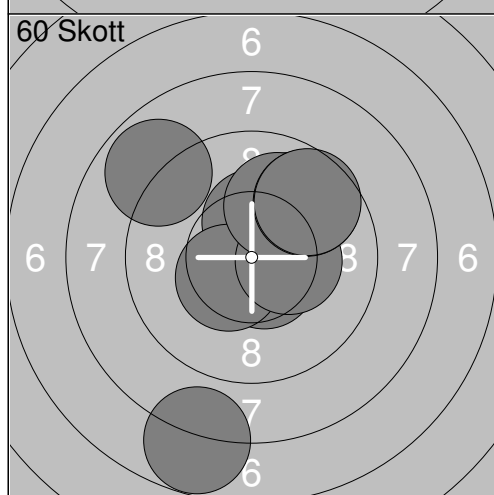

31:	10.6x	↘
32:	8.9	↖
33:	7.8	↓
34:	10.4x	↑
35:	10.4x	↙
36:	10.3x	→
37:	9.9	↗
38:	10.0	↑
39:	9.7	↗
40:	9.6	↗
Serie	97.6	
Total	387.9	

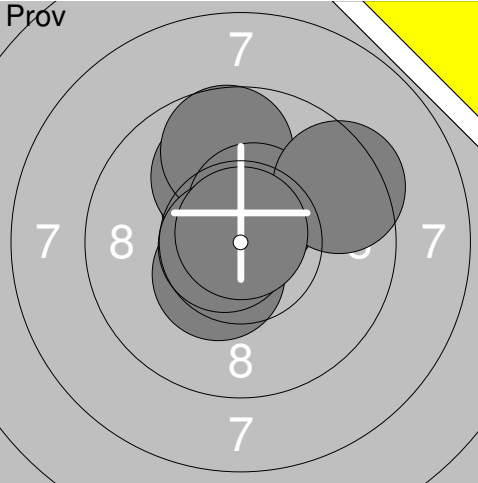
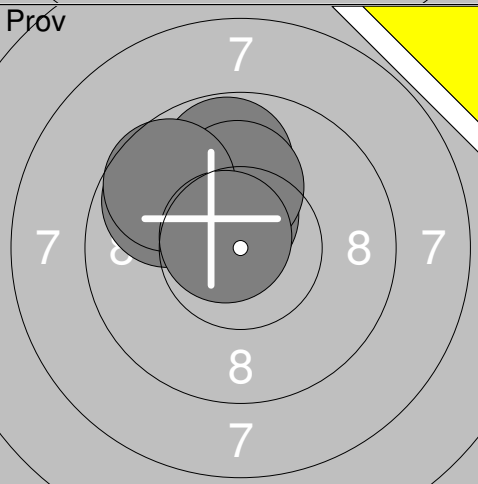
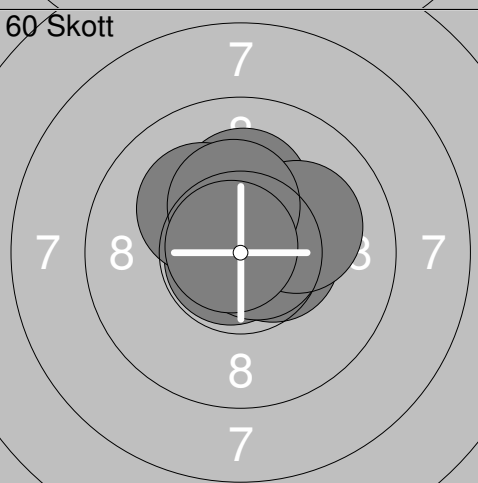
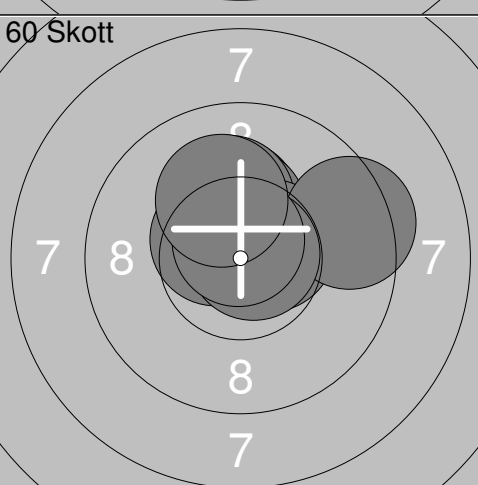
Skjutlag	Tavla	Elvina Bohman		
3	37			
S	Gideå Skf			
08.04.2017	UMEKULAN 2017	Umeå skytteallians		
Prov		1: 10.4x ↙ 2: 10.4x ↗ 3: 10.1 ↗ 4: 10.0 ↗ 6: 9.7 ↗ 7: 10.5x ↗ 8: 9.4 ↗ 9: 10.7x ← 10: 10.8x ↑	12: 10.3x ↗ 13: 10.1 → 14: 10.5x → 15: 10.1 ← 16: 10.4x ← 17: 10.8x ← 18: 10.5x ↑ 19: 10.7x ↗ 20: 10.9x ↑	
	Serie	92.0	Serie	94.3
	Total	0.0	Total	0.0
Prov		21: 9.8 ↑ 22: 9.8 ↗ 23: 10.5x ↑ 24: 10.1 ↑ 25: 9.7 ↗ 26: 10.7x ↗	60 Skott	1: 9.4 ↑ 2: 10.6x ↗ 3: 10.5x ↑ 4: 10.4x ← 5: 10.8x ↑ 6: 9.6 ↑ 7: 10.7x → 8: 10.4x ↑ 9: 10.6x ↗ 10: 10.3x ↗
	Serie	60.6	Serie	103.3
	Total	0.0	Total	103.3
60 Skott		11: 10.2x → 12: 10.2x ↑ 13: 10.8x ← 14: 10.6x → 15: 10.5x → 16: 10.2x ↗ 17: 10.7x → 18: 10.1 → 19: 10.3x ↑ 20: 10.8x ↗	60 Skott	21: 9.4 ↑ 22: 10.6x ↗ 23: 10.5x ↑ 24: 10.4x → 25: 10.3x ↑ 26: 9.8 ↗ 27: 10.0 ↗ 28: 10.7x ← 29: 9.7 ↑ 30: 10.1 ↑
	Serie	104.4	Serie	101.5
	Total	207.7	Total	309.2
60 Skott		31: 10.2x ↑ 32: 10.4x ↗ 33: 10.5x ↗ 34: 10.3x ↑ 35: 10.2x ↑ 36: 10.5x → 37: 9.4 → 38: 10.8x → 39: 10.7x ↑ 40: 10.1 ↗		
	Serie	103.1		
	Total	412.3		

<p>Prov</p>	<p>1: 10.5x ↘ 2: 9.3 ↗ 3: 10.3x ↘ 4: 10.1 ↑ 5: 10.4x ➔ 6: 9.3 ← 7: 9.0 ➔ 8: 9.6 ↗ 9: 9.0 ↑ 10: 10.2x ↗</p> <p>Serie 97.7 Total 0.0</p>	<p>Prov</p>	<p>11: 8.9 ➔ 12: 10.2x ↘ 13: 8.5 ↑ 14: 10.0 ↖ 15: 9.8 ↓ 16: 10.5x ↘</p> <p>Serie 57.9 Total 0.0</p>
<p>60 Skott</p>	<p>1: 9.3 ↘ 2: 10.2x ↘ 3: 10.3x ➔ 4: 9.8 ↑ 5: 10.0 ➔ 6: 8.6 ➔ 7: 10.2x ↑ 8: 10.5x ← 9: 9.4 ↓ 10: 10.5x ➔</p> <p>Serie 98.8 Total 98.8</p>	<p>60 Skott</p>	<p>11: 9.4 ↗ 12: 8.9 ➔ 13: 10.3x ← 14: 10.0 ↖ 15: 10.6x ➔ 16: 10.2x ➔ 17: 9.9 ➔ 18: 10.3x ↑ 19: 10.6x ↗ 20: 9.1 ↑</p> <p>Serie 99.3 Total 198.1</p>
<p>60 Skott</p>	<p>21: 7.9 ➔ 22: 8.9 ➔ 23: 8.8 ↑ 24: 9.7 ↘ 25: 9.7 ↑ 26: 9.9 ← 27: 9.0 ↑ 28: 10.2x ↘ 29: 6.9 ↘ 30: 9.6 ➔</p> <p>Serie 90.6 Total 288.7</p>	<p>60 Skott</p>	<p>31: 9.8 ➔ 32: 8.3 ↑ 33: 10.1 ↑ 34: 9.7 ↗ 35: 10.2x ← 36: 9.4 ➔ 37: 10.3x ← 38: 9.8 ↑ 39: 8.7 ↗ 40: 9.4 ↑</p> <p>Serie 95.7 Total 384.4</p>

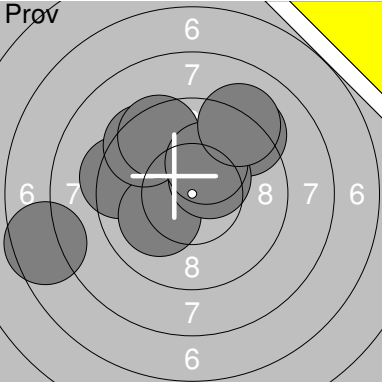
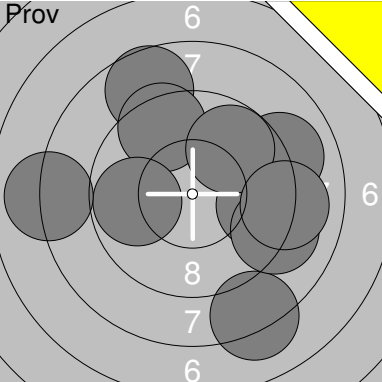
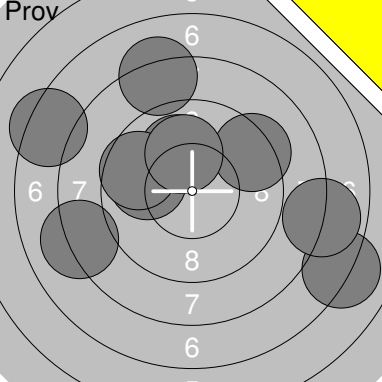
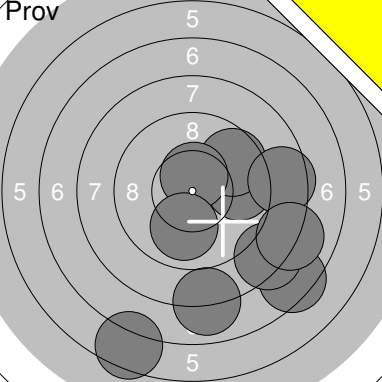
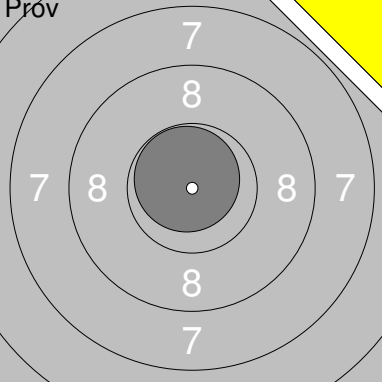
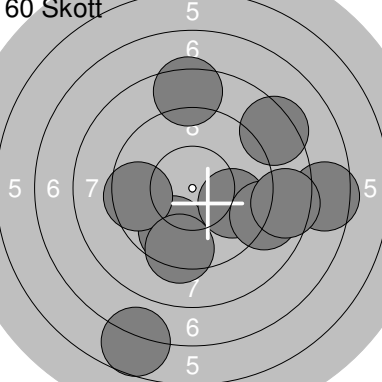
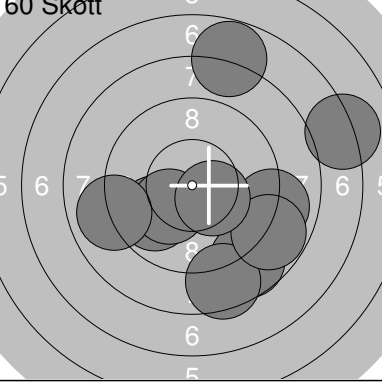
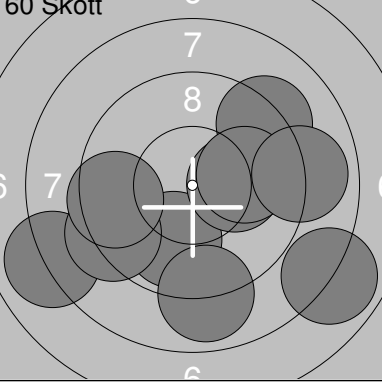
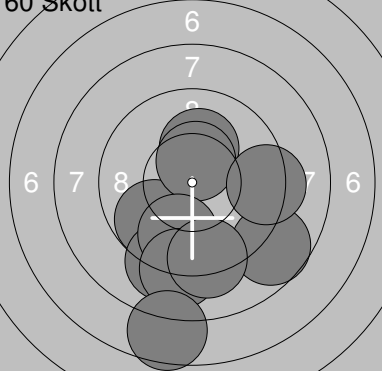
Skjutlag	Tavla	Cecilia Bäckman	
3	39		
S	Gideå Skf		
08.04.2017	UMEKULAN 2017	Umeå skytteallians	
	1: 10.2x ↑ 2: 9.4 ← 3: 7.6 ← 4: 10.1 ↙ 5: 9.2 ↗ 6: 9.5 ↗ 7: 10.4x ↗ 8: 9.5 ↗ 9: 10.2x ↗ 10: 9.1 ↗		11: 8.2 ↓ 12: 8.7 ↗ 13: 9.0 → 14: 9.5 ↗ 15: 9.8 ← 16: 8.0 ← 17: 9.5 → 18: 9.1 ↘ 19: 9.8 ↗ 20: 9.1 →
	Serie 95.2		Serie 90.7
	Total 0.0		Total 0.0
	21: 9.3 ↗ 22: 8.2 ↑ 23: 9.9 ← 24: 10.0 ↗ 25: 8.1 ← 26: 7.3 ↙ 27: 9.6 ↙ 28: 10.1 ↗ 29: 7.1 ↘ 30: 7.9 →		31: 7.4 ↓ 32: 8.3 ↓ 33: 9.7 → 34: 9.6 ↗ 35: 6.5 ↓ 36: 8.5 → 37: 10.5x ↑ 38: 8.1 → 39: 8.0 ↓ 40: 10.0 ↓
	Serie 87.5		Serie 86.6
	Total 0.0		Total 0.0
	41: 10.8x ↗		1: 8.4 ↗ 2: 9.7 ↓ 3: 9.8 → 4: 9.5 ← 5: 6.7 ↓ 6: 8.4 ↑ 7: 7.5 → 8: 9.0 → 9: 9.3 ↓ 10: 8.5 →
	Serie 10.8		Serie 86.8
	Total 0.0		Total 86.8
	11: 8.7 ↓ 12: 9.0 → 13: 9.8 ↙ 14: 8.5 ↓ 15: 8.8 ↓ 16: 7.1 → 17: 10.2x ↙ 18: 10.4x ↘ 19: 9.0 ← 20: 7.8 ↑		21: 9.9 ↓ 22: 8.0 ← 23: 9.2 ← 24: 9.5 ← 25: 8.9 ↓ 26: 9.2 ↗ 27: 10.2x → 28: 10.0 → 29: 8.9 → 30: 7.9 ↘
	Serie 89.3		Serie 91.7
	Total 176.1		Total 267.8
	31: 8.7 ↓ 32: 9.8 ↙ 33: 9.1 ↓ 34: 10.2x ↑ 35: 10.5x ↑ 36: 9.3 → 37: 9.8 ↓ 38: 9.0 ↓ 39: 9.2 ↓ 40: 7.6 ↓		
	Serie 93.2		
	Total 361.0		

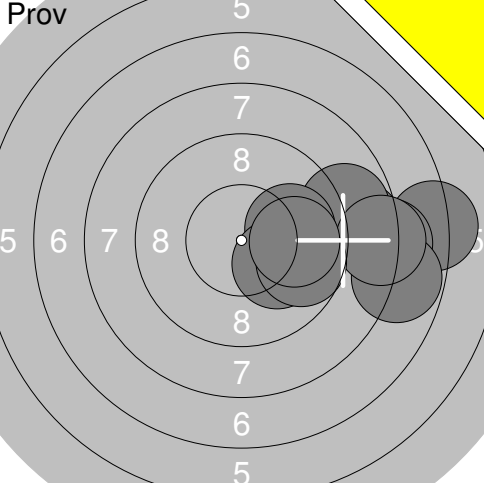
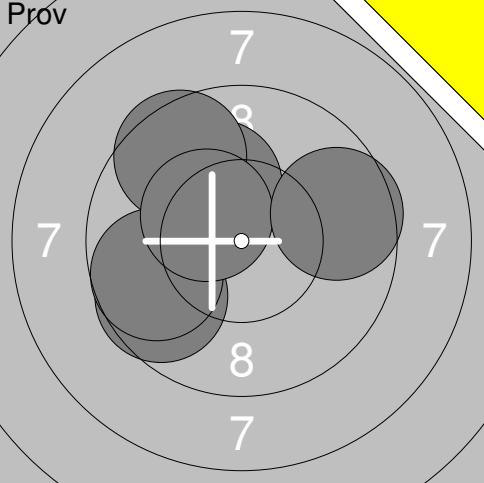
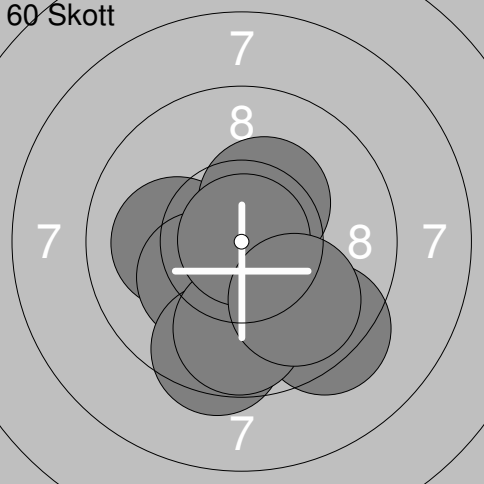
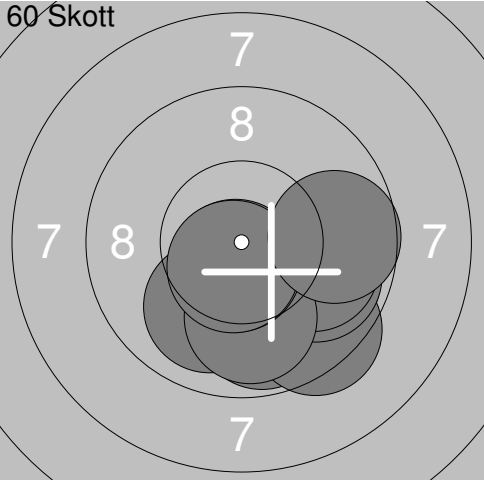
Skjutlag	Tavla	Elliot Nilsson		
3	40			
S	Drängsmarks Skf			
08.04.2017	UMEKULAN 2017	Umeå skytteallians		
Prov		1: 7.2 → 2: 8.6 → 3: 8.8 → 4: 8.1 → 5: 7.8 → 6: 10.0 → 7: 8.2 → 8: 10.1 ↘ 9: 9.7 ↘ 10: 9.9 → Serie 88.4 Total 0.0	11: 10.1 ↘ 12: 9.6 → 13: 9.6 → 14: 10.3x → 15: 10.6x ← 16: 10.0 ↘ 17: 8.5 ↘ 18: 9.6 ← 19: 9.7 ← 20: 10.0 ↘ Serie 98.0 Total 0.0	
Prov		21: 10.1 ↗ 22: 9.5 ↗ 23: 9.6 ← 24: 9.7 ← 25: 10.4x ↗ 26: 9.6 → Serie 58.9 Total 0.0	60 Skott	1: 10.6x ↘ 2: 10.7x ↘ 3: 9.9 ↗ 4: 10.8x ← 5: 10.4x ↘ 6: 10.2x → 7: 10.3x ↘ 8: 9.9 ↘ 9: 9.5 ↘ 10: 10.7x ↗ Serie 103.0 Total 103.0
60 Skott		11: 10.9x → 12: 10.2x ↘ 13: 10.1 ← 14: 10.2x ← 15: 10.3x ↗ 16: 9.3 ↘ 17: 9.5 ↘ 18: 9.8 ↘ 19: 10.9x ↗ 20: 9.9 ↘ Serie 101.1 Total 204.1	60 Skott	21: 10.6x ← 22: 10.3x ↗ 23: 10.2x ↘ 24: 8.8 ← 25: 9.4 ↘ 26: 10.6x ↘ 27: 9.8 ↘ 28: 10.3x ↘ 29: 9.8 → 30: 10.7x ↘ Serie 100.5 Total 304.6
60 Skott		31: 9.8 ↘ 32: 9.8 ↘ 33: 9.4 ↘ 34: 9.9 ↘ 35: 9.9 → 36: 10.0 ↘ 37: 9.9 ↘ 38: 10.6x ↘ 39: 10.6x ↘ 40: 9.7 → Serie 99.6 Total 404.2		