

Skjutlag	Tavla	Alwa Wiklund			
1	11				Jä
Vindeln	Aspås				
18.03.2017	SM & JSM Luftgevär 2017	Ramselefors SKF			
Prov		1: 9.5 → 2: 8.4 ← 3: 10.4x ← 4: 8.8 ↓ 5: 10.2x ← 6: 10.3x ↗ 7: 9.9 ← 8: 8.7 ↓ 9: 10.7x ↗ 10: 9.5 ←	Prov		11: 10.1 ↗ 12: 10.1 ← 13: 10.2x ↗ 14: 9.9 ↓ 15: 9.3 ← 16: 10.4x ↗ 17: 9.9 ↗ 18: 8.5 ↓ 19: 9.5 ↓ 20: 10.1 ↓
		Serie	96.4	Serie	98.0
		Total	0.0	Total	0.0
Prov		21: 8.4 ← 22: 10.1 ↗	40 Skott		1: 9.8 ↓ 2: 8.5 ← 3: 10.5x → 4: 10.0 ↗ 5: 10.1 ↓ 6: 8.8 ↓ 7: 9.5 ← 8: 9.2 ↗ 9: 8.9 → 10: 9.9 ←
		Serie	18.5	Serie	95.2
		Total	0.0	Total	95.2
40 Skott		11: 10.8x ↗ 12: 8.2 ↓ 13: 9.9 ↗ 14: 9.5 ← 15: 8.8 → 16: 9.8 ← 17: 10.3x → 18: 9.9 → 19: 9.8 → 20: 7.8 ←	40 Skott		21: 9.8 ← 22: 10.0 ← 23: 9.1 ↗ 24: 10.2x ← 25: 9.4 → 26: 8.9 ↗ 27: 9.9 ↗ 28: 10.0 ← 29: 9.4 ↓ 30: 10.6x →
		Serie	94.8	Serie	97.3
		Total	190.0	Total	287.3
40 Skott		31: 9.6 → 32: 10.2x → 33: 9.7 ↗ 34: 8.9 ↗ 35: 9.2 ↓ 36: 10.4x ← 37: 10.0 → 38: 9.0 ↗ 39: 10.4x ← 40: 10.2x →			
		Serie	97.6		
		Total	384.9		

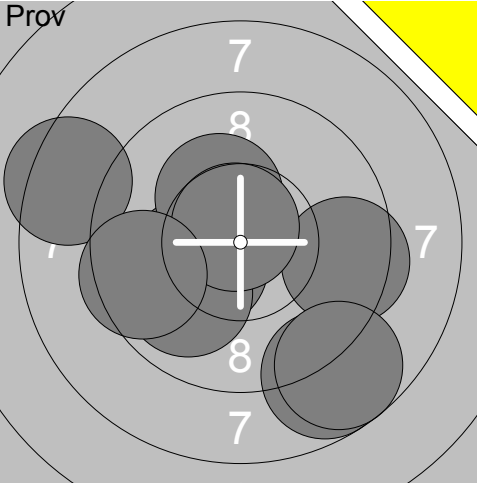

1:	6.7	→
2:	5.9	→
3:	8.2	→
4:	8.7	→
5:	8.6	→
6:	8.0	↓
7:	8.9	↙
8:	9.5	←
9:	9.7	↓
10:	10.1	↗
Serie	84.3	
Total	0.0	

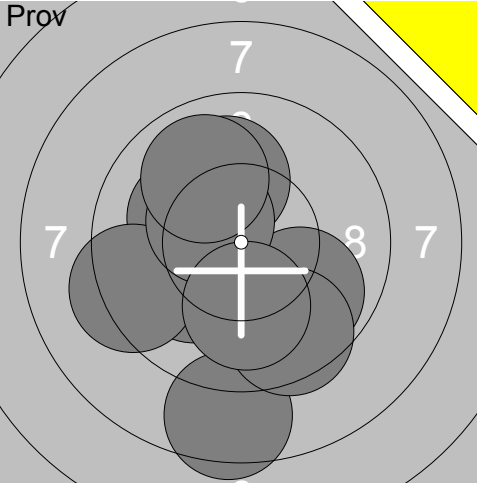
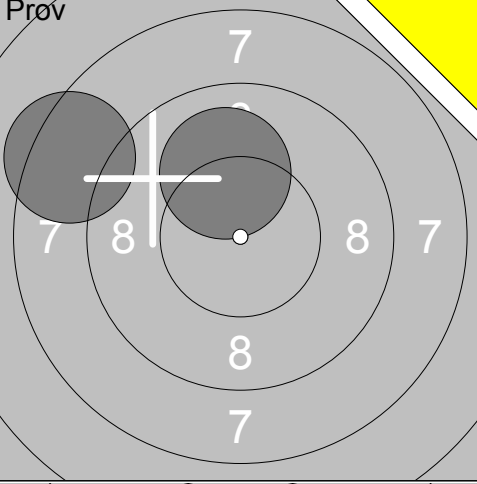
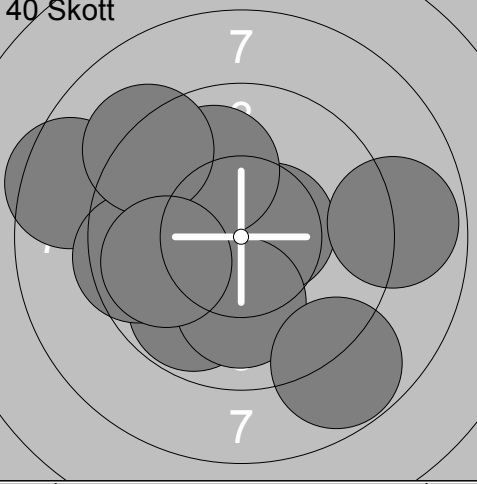
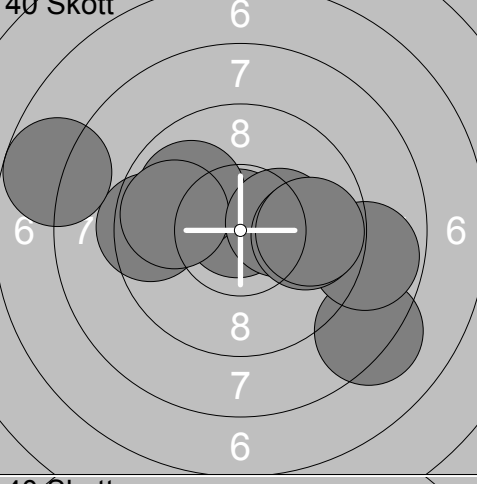
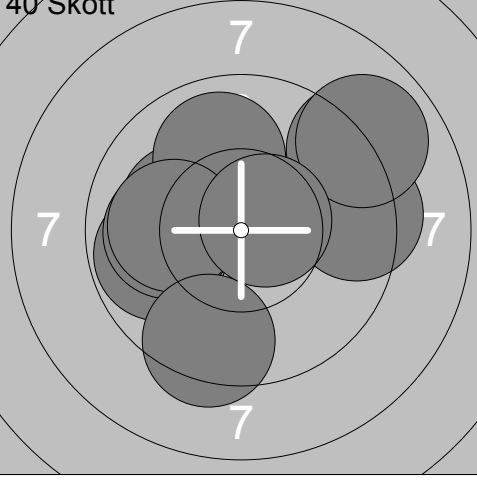
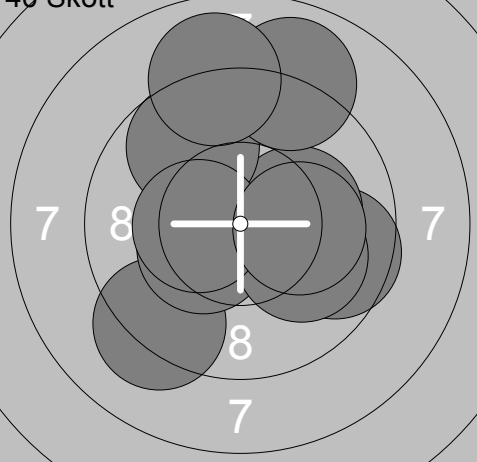
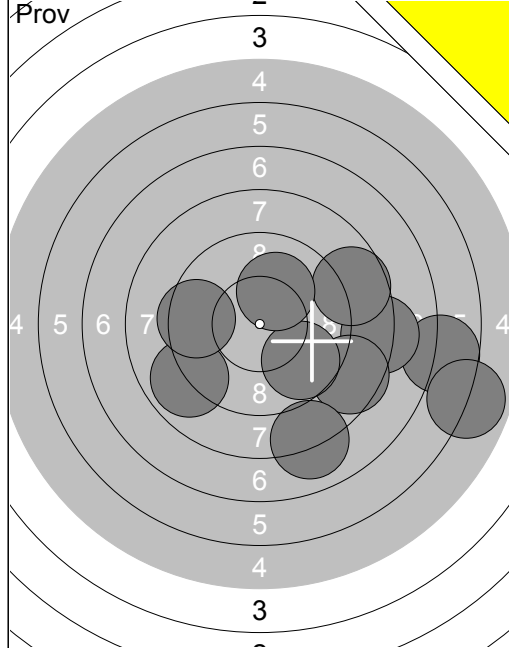
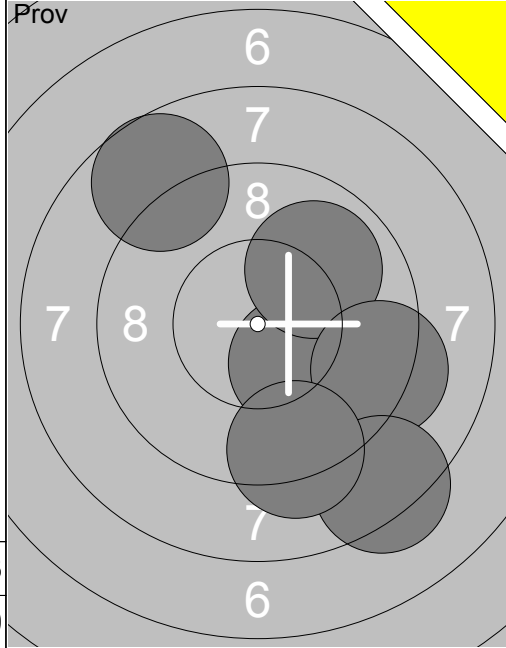

11:	10.2	↘
12:	9.9	↗
13:	8.7	↖
14:	9.3	→
15:	8.3	↓
16:	9.2	↓
Serie	55.6	
Total	0.0	

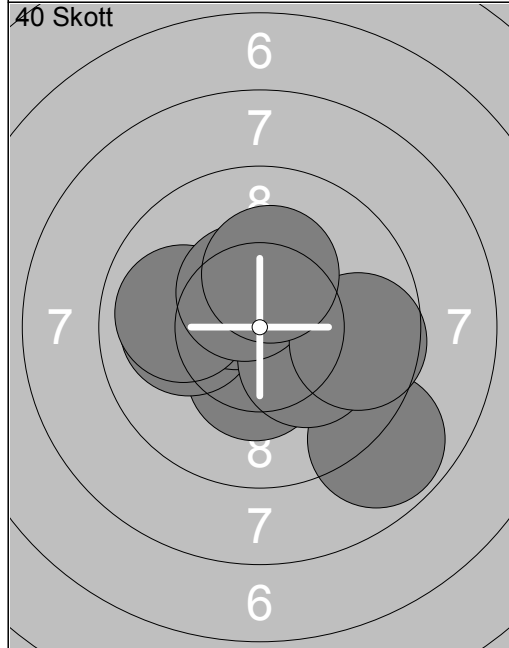

1:	10.4	↘
2:	10.1	→
3:	10.0	←
4:	10.5	↖
5:	9.9	←
6:	8.8	↓
7:	10.2	↘
8:	10.5	↗
9:	9.7	→
10:	10.2	↗
Serie	100.3	
Total	100.3	

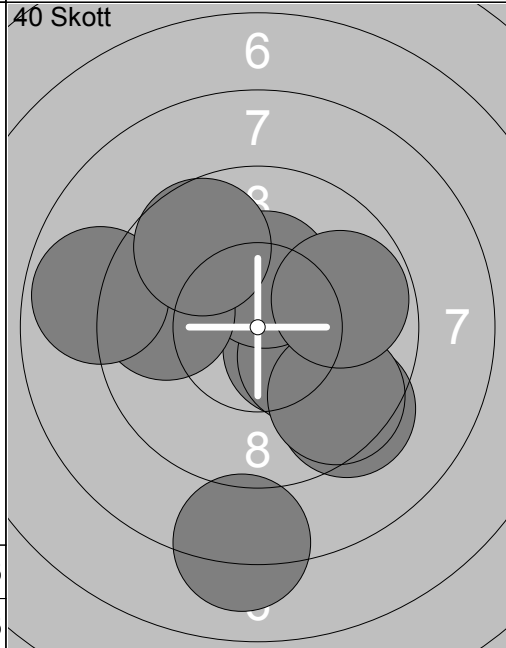

11:	9.4	↘
12:	8.1	↓
13:	10.4	↘
14:	10.2	↘
15:	9.6	↘
16:	10.3	↗
17:	9.7	←
18:	8.9	←
19:	9.7	↖
20:	9.8	→
Serie	96.1	
Total	196.4	

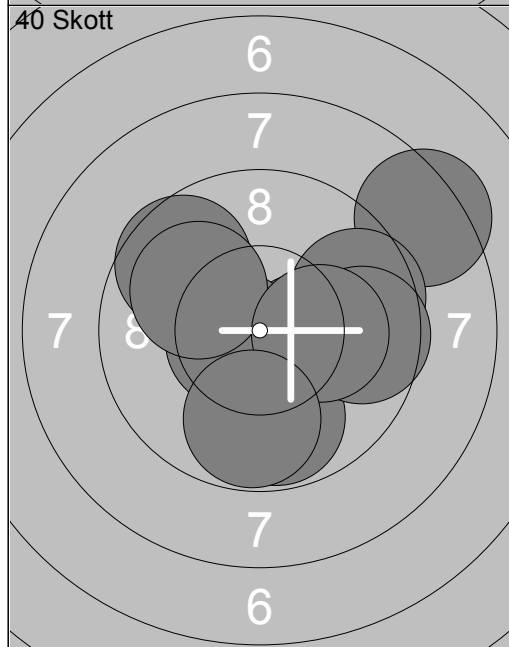

21:	10.3	↗
22:	10.6	↖
23:	9.6	↖
24:	8.4	↗
25:	10.0	↖
26:	9.6	→
27:	9.8	↓
28:	9.6	→
29:	10.2	↗
30:	9.8	↓
Serie	97.9	
Total	294.3	

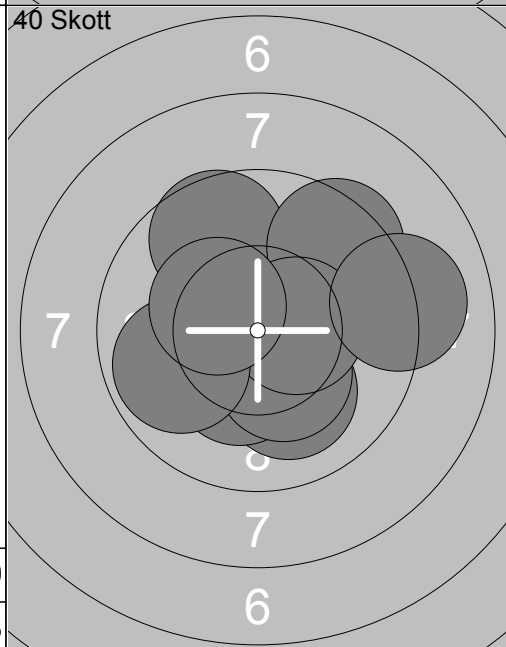

31:	9.7	↖
32:	10.6	↗
33:	10.1	↓
34:	9.5	↗
35:	10.3	↘
36:	10.3	↘
37:	10.4	↗
38:	9.9	←
39:	10.3	↖
40:	9.1	→
Serie	100.2	
Total	394.5	

Skjuttag	Tavla	Elinore Selin	
1	14		
Vindeln	Aspås		Jä
18.03.2017	SM & JSM Luftgevär 2017	Ramselefors SKF	
Prov		1: 10.3x ➤ 2: 10.5x ➤ 3: 9.1 ↗ 5: 9.0 ↘ 6: 8.0 ➡ 7: 9.5 ↓ 8: 9.3 ↘ 9: 9.2 ↑ 10: 7.6 ←	11: 9.9 ↘ 12: 9.4 ↙ 13: 8.2 ↓ 14: 9.1 ↘ 15: 8.2 ➡ 16: 9.2 ↓ 17: 9.7 ↙ 18: 9.3 ← 19: 9.1 ↓
	Serie 82.5 Total 0.0	Serie 82.1 Total 0.0	
40 Skott		1: 8.0 ➡ 2: 10.3x ↘ 3: 10.2x ↘ 4: 10.8x ↘ 5: 10.3x ↘ 6: 9.7 ↗ 7: 8.4 ↗ 8: 10.6x ↘ 9: 10.7x ↘ 10: 10.6x ←	11: 8.7 ➡ 12: 9.2 ← 13: 10.3x ↘ 14: 7.8 ↘ 15: 10.6x ↙ 16: 10.8x ↘ 17: 10.6x ↓ 18: 9.0 ↗ 19: 10.0 ➡ 20: 9.1 ➡
	Serie 99.6 Total 99.6	Serie 96.1 Total 195.7	
40 Skott		21: 9.9 ↑ 22: 8.6 ➡ 23: 10.0 ← 24: 9.2 ↑ 25: 10.3x ➤ 26: 9.3 ↓ 27: 10.6x ➤ 28: 10.0 ↑ 29: 10.8x ↗ 30: 9.0 ➡	31: 9.1 ↙ 32: 8.8 ➡ 33: 7.7 ➡ 34: 9.8 ↑ 35: 6.6 ➡ 36: 9.0 ↓ 37: 9.2 ← 38: 8.4 ↑ 39: 8.6 ↗ 40: 10.5x ←
	Serie 97.7 Total 293.4	Serie 87.7 Total 381.1	

<p>Prov</p> 	<p>1: 9.2 ↗ 2: 9.7 → 3: 9.3 ↑ 4: 7.8 ↗ 5: 10.5x→ 6: 8.3 ↑ 7: 9.0 → 8: 9.2 ↑ 9: 9.2 ↗ 10: 10.3x↓</p> <p>Serie 92.5 Total 0.0</p>	<p>Prov</p> 	<p>11: 9.0 ↗ 12: 8.7 ↑ 13: 8.6 →</p> <p>Serie 26.3 Total 0.0</p>
--	---	--	--

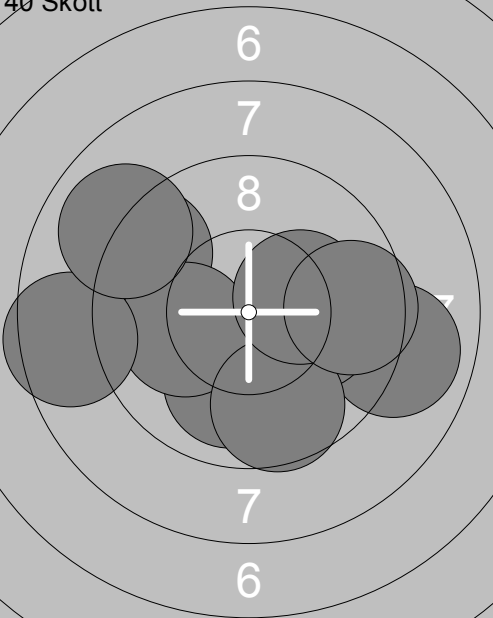
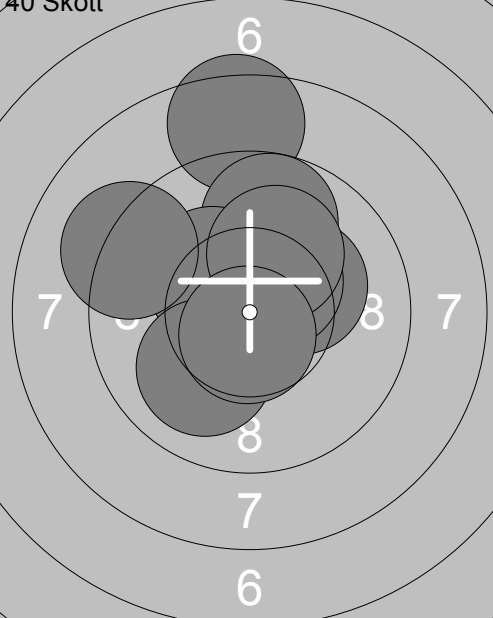
<p>40 Skott</p> 	<p>1: 8.9 → 2: 10.1 → 3: 10.0 ↓ 4: 9.3 ↖ 5: 10.1 ← 6: 9.7 ↓ 7: 8.5 ← 8: 10.2x→ 9: 9.0 ↖ 10: 9.6 →</p> <p>Serie 95.4 Total 95.4</p>	<p>40 Skott</p> 	<p>11: 10.2x↗ 12: 10.5x↗ 13: 8.5 ↑ 14: 10.4x↗ 15: 9.8 ↑ 16: 10.3x↖ 17: 9.2 ↖ 18: 10.1 ↑ 19: 10.0 ↘ 20: 10.7x↓</p> <p>Serie 99.7 Total 195.1</p>
---	--	---	---

<p>40 Skott</p> 	<p>21: 10.1 ↑ 22: 9.7 ↖ 23: 10.4x↗ 24: 10.2x↗ 25: 8.8 ← 26: 9.2 ← 27: 9.9 ↗ 28: 8.3 ← 29: 9.0 ← 30: 9.2 →</p> <p>Serie 94.8 Total 289.9</p>	<p>40 Skott</p> 	<p>31: 10.2x↗ 32: 10.7x↗ 33: 9.3 → 34: 9.9 ↖ 35: 10.4x↗ 36: 10.3x↓ 37: 10.7x↖ 38: 8.8 ← 39: 9.4 → 40: 9.9 ↗</p> <p>Serie 99.6 Total 389.5</p>
--	---	--	---

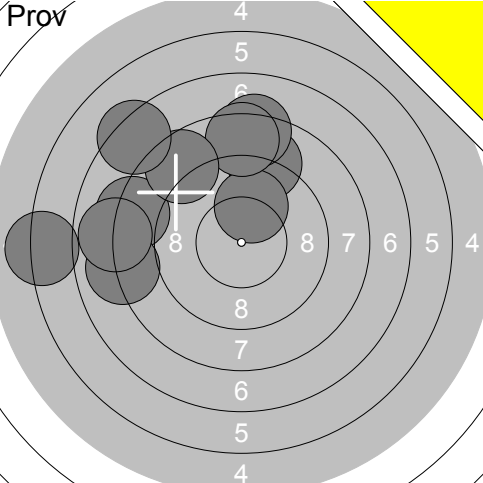
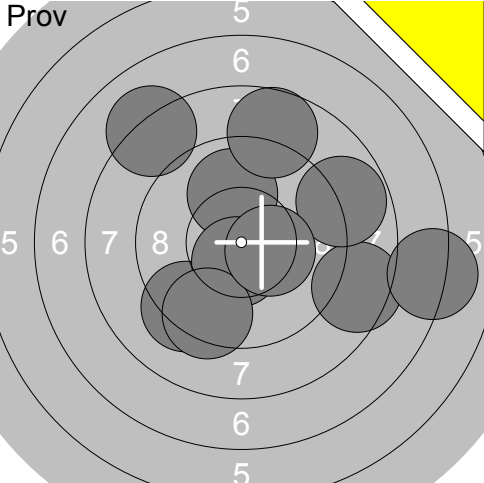
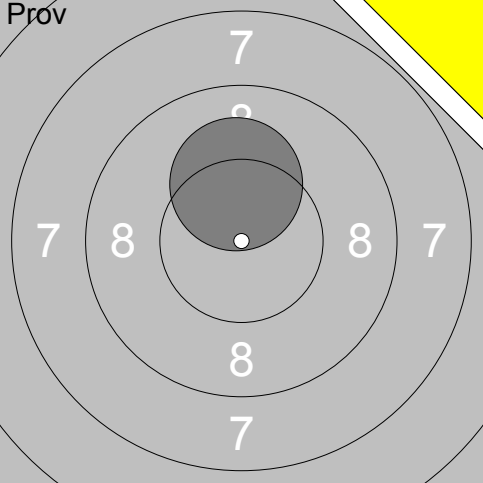
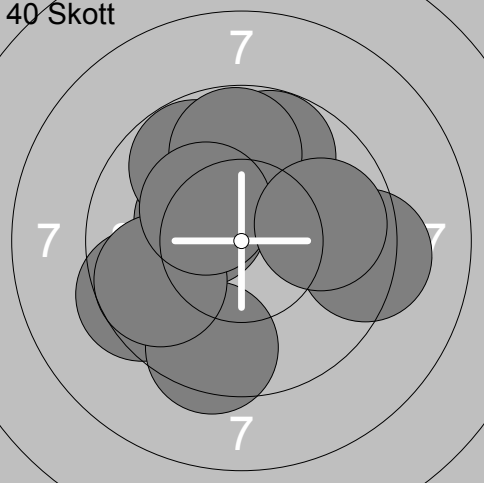
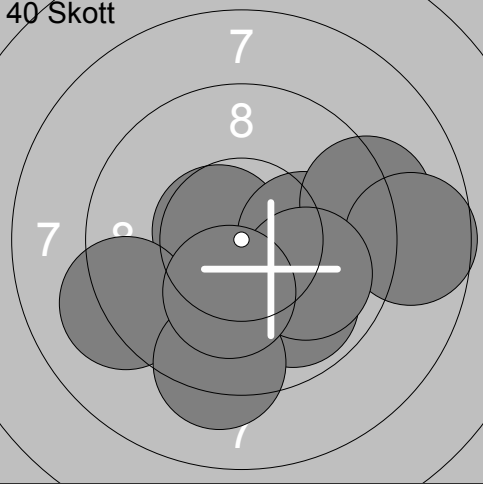
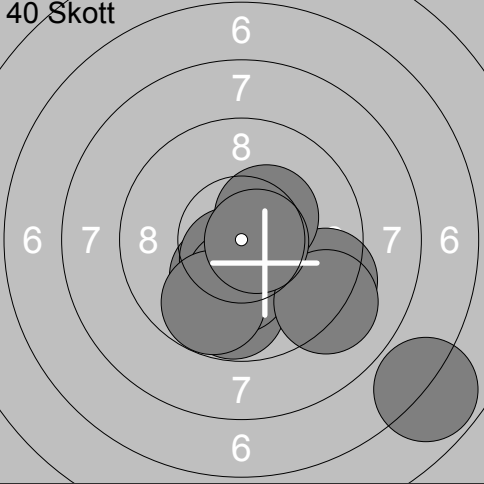
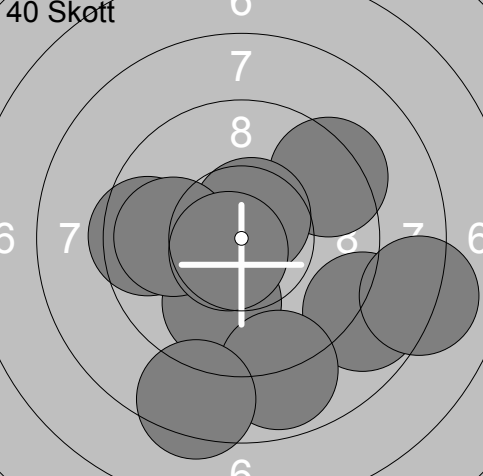
Skjuttlag <b>1</b>	Tavla <b>17</b>	<b>Emilia Nordin</b>	
Vindeln	Umeå		Vb
18.03.2017	SM & JSM Luftgevär 2017	Ramselefors SKF	
Prov 	1: 8.2 ← 2: 9.0 ↑ 3: 8.3 ↑ 4: 10.0 ↑ 5: 8.5 ↑ 6: 8.6 ↗ 7: 8.0 ← 8: 7.3 ↗ 9: 6.1 ← 10: 7.9 ← Serie 81.9 Total 0.0	Prov 	11: 8.1 ↗ 12: 10.0 ↑ 13: 8.5 → 14: 9.3 ↓ 15: 7.1 → 16: 10.6x ↓ 17: 8.8 → 18: 9.4 ↓ 19: 10.4x → 20: 8.7 ↑ Serie 90.9 Total 0.0
Prov 	21: 10.2x ↑ Serie 10.2 Total 0.0	40 Skott 	1: 10.3x ↖ 2: 9.4 ↖ 3: 9.8 ↗ 4: 9.5 ↓ 5: 9.7 ↖ 6: 9.8 ↑ 7: 9.8 ↑ 8: 9.3 → 9: 10.3x ↗ 10: 9.9 → Serie 97.8 Total 97.8
40 Skott 	11: 10.6x ↖ 12: 10.1 → 13: 9.2 → 14: 10.0 ↓ 15: 8.7 → 16: 9.9 ↓ 17: 9.2 ↖ 18: 10.0 → 19: 9.3 ↓ 20: 10.2x ↓ Serie 97.2 Total 195.0	40 Skott 	21: 9.3 → 22: 10.4x ↗ 23: 10.2x ↓ 24: 10.6x ↓ 25: 6.8 ↘ 26: 9.8 ↓ 27: 10.2x ↓ 28: 9.8 ↓ 29: 9.1 ↘ 30: 10.7x → Serie 96.9 Total 291.9
40 Skott 	31: 9.3 ↗ 32: 8.8 ↘ 33: 10.6x ↗ 34: 9.5 ← 35: 9.9 ↓ 36: 8.9 ↓ 37: 8.1 → 38: 9.9 ← 39: 10.7x ↖ 40: 8.4 ↓ Serie 94.1 Total 386.0		

	<p>1: 10.6x ↗</p> <p>2: 10.0 ↗</p> <p>3: 9.2 →</p> <p>4: 8.7 ↗</p> <p>5: 8.7 ↗</p> <p>6: 9.3 ↑</p> <p>7: 10.2x ↗</p> <p>8: 10.5x ↓</p> <p>9: 10.6x ↗</p> <p>10: 8.4 ↖</p> <p>Serie 96.2</p> <p>Total 0.0</p>		<p>11: 9.9 ↗</p> <p>12: 9.6 ↑</p> <p>13: 8.8 ↗</p> <p>14: 9.7 →</p> <p>15: 8.7 ↑</p> <p>16: 10.5x ↗</p> <p>17: 10.2x ↗</p> <p>18: 9.9 ↗</p> <p>19: 9.8 ↖</p> <p>20: 10.2x ↖</p> <p>Serie 97.3</p> <p>Total 0.0</p>
--	--	--	--

	<p>1: 10.3x →</p> <p>2: 8.3 →</p> <p>3: 9.6 →</p> <p>4: 10.6x →</p> <p>5: 10.5x ↗</p> <p>6: 9.0 ↖</p> <p>7: 9.2 →</p> <p>8: 9.7 ↗</p> <p>9: 10.4x ↗</p> <p>10: 9.7 ↖</p> <p>Serie 97.3</p> <p>Total 97.3</p>		<p>11: 9.7 ↗</p> <p>12: 10.0 →</p> <p>13: 10.0 ↘</p> <p>14: 9.4 ↗</p> <p>15: 9.7 ↖</p> <p>16: 10.7x ↓</p> <p>17: 9.9 ↖</p> <p>18: 8.6 →</p> <p>19: 10.0 ↖</p> <p>20: 10.7x →</p> <p>Serie 98.7</p> <p>Total 196.0</p>
--	--	--	---

	<p>21: 10.2x ↘</p> <p>22: 9.6 ↖</p> <p>23: 9.9 ↓</p> <p>24: 8.1 ↖</p> <p>25: 10.4x ↘</p> <p>26: 10.3x ↗</p> <p>27: 10.4x ↖</p> <p>28: 10.6x →</p> <p>29: 10.1 ↗</p> <p>30: 6.2 ↖</p> <p>Serie 95.8</p> <p>Total 291.8</p>		<p>31: 10.0 ↓</p> <p>32: 10.8x ↗</p> <p>33: 9.6 ↓</p> <p>34: 10.4x ↗</p> <p>35: 9.2 ↘</p> <p>36: 9.5 ↖</p> <p>37: 10.1 ↓</p> <p>38: 9.9 ↖</p> <p>39: 9.7 ↖</p> <p>40: 8.7 ↖</p> <p>Serie 97.9</p> <p>Total 389.7</p>
--	---	--	--

	<p>1: 7.7 →</p> <p>2: 10.2x→</p> <p>3: 8.7 ↗</p> <p>4: 9.6 ↗</p> <p>5: 9.5 ↗</p> <p>6: 9.1 →</p> <p>7: 9.5 ↓</p> <p>8: 9.5 ←</p> <p>9: 8.4 ↓</p> <p>10: 9.0 ↓</p>	
Serie 91.2		Serie 10.1
Total 0.0		Total 0.0

<p>40 Skott</p>	<p>1: 9.9 ↑</p> <p>2: 10.4x↗</p> <p>3: 9.7 ←</p> <p>4: 9.6 ↑</p> <p>5: 9.9 ↗</p> <p>6: 10.0 →</p> <p>7: 10.5x↘</p> <p>8: 10.0 ↗</p> <p>9: 7.6 ↓</p> <p>10: 10.0 ↓</p>	<p>40 Skott</p>
Serie 97.6		Serie 96.8
Total 97.6		Total 194.4

<p>40 Skott</p>	<p>21: 10.1 ↓</p> <p>22: 9.0 ↘</p> <p>23: 9.8 →</p> <p>24: 10.0 →</p> <p>25: 9.6 ↓</p> <p>26: 7.9 ←</p> <p>27: 8.7 ←</p> <p>28: 9.5 ↗</p> <p>29: 9.1 ←</p> <p>30: 9.4 ↑</p>	<p>40 Skott</p>
Serie 93.1		Serie 93.9
Total 287.5		Total 381.4

<p>Prov</p>	<p>1: 8.6 ↑</p> <p>2: 10.1 ↙</p> <p>3: 9.2 ↗</p> <p>4: 9.3 ↑</p> <p>5: 10.9x↗</p> <p>6: 9.1 →</p> <p>7: 8.6 →</p> <p>8: 9.6 ↓</p> <p>9: 9.5 ↗</p> <p>10: 9.4 ←</p> <p>Serie 94.3</p> <p>Total 0.0</p>	<p>Prov</p>	<p>11: 9.4 ←</p> <p>12: 9.5 →</p> <p>13: 9.0 ↙</p> <p>14: 10.5x↗</p> <p>15: 10.7x↗</p> <p>16: 9.7 ↓</p> <p>17: 9.8 ↘</p> <p>18: 9.8 ↓</p> <p>Serie 78.4</p> <p>Total 0.0</p>
<p>40 Skott</p>	<p>1: 9.9 ↓</p> <p>2: 10.0 ↓</p> <p>3: 9.3 ↗</p> <p>4: 10.1 ↓</p> <p>5: 10.8x↘</p> <p>6: 9.1 ↗</p> <p>7: 9.9 ↑</p> <p>8: 9.4 →</p> <p>9: 10.1 ←</p> <p>10: 9.8 ↓</p> <p>Serie 98.4</p> <p>Total 98.4</p>	<p>40 Skott</p>	<p>11: 10.0 ↙</p> <p>12: 9.6 ↗</p> <p>13: 9.0 ↗</p> <p>14: 10.4x↘</p> <p>15: 9.8 ←</p> <p>16: 10.0 ↙</p> <p>17: 9.9 ↘</p> <p>18: 8.7 ↗</p> <p>19: 10.1 ↙</p> <p>20: 9.5 ↓</p> <p>Serie 97.0</p> <p>Total 195.4</p>
<p>40 Skott</p>	<p>21: 9.6 ←</p> <p>22: 9.0 →</p> <p>23: 9.9 ↗</p> <p>24: 10.4x↙</p> <p>25: 10.7x↘</p> <p>26: 9.5 ←</p> <p>27: 10.7x→</p> <p>28: 8.3 →</p> <p>29: 8.7 →</p> <p>30: 10.4x←</p> <p>Serie 97.2</p> <p>Total 292.6</p>	<p>40 Skott</p>	<p>31: 9.4 ↓</p> <p>32: 8.4 →</p> <p>33: 10.7x↓</p> <p>34: 10.5x←</p> <p>35: 10.8x↗</p> <p>36: 10.6x↙</p> <p>37: 9.8 ↗</p> <p>38: 9.6 ↓</p> <p>39: 9.6 ↗</p> <p>40: 10.5x↗</p> <p>Serie 99.9</p> <p>Total 392.5</p>



<p>Prov</p>	<p>Prov</p>	
Serie 88.9	Serie 40.3	
Total 0.0	Total 0.0	

<p>40 Skott</p>	<p>40 Skott</p>	
Serie 96.0	Serie 93.7	
Total 96.0	Total 189.7	

<p>40 Skott</p>	<p>40 Skott</p>	
Serie 97.6	Serie 91.2	
Total 287.3	Total 378.5	

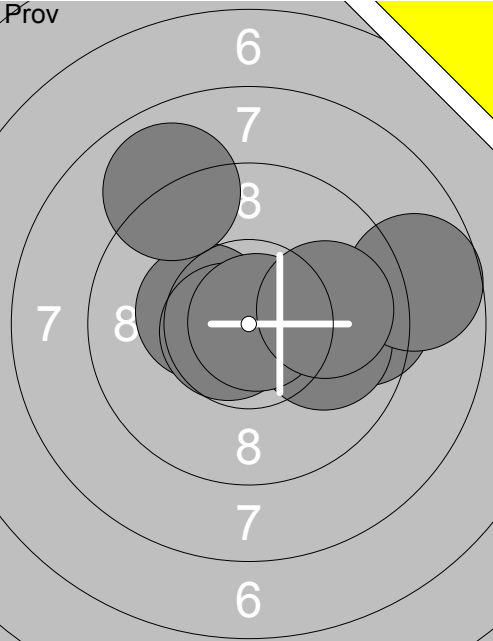
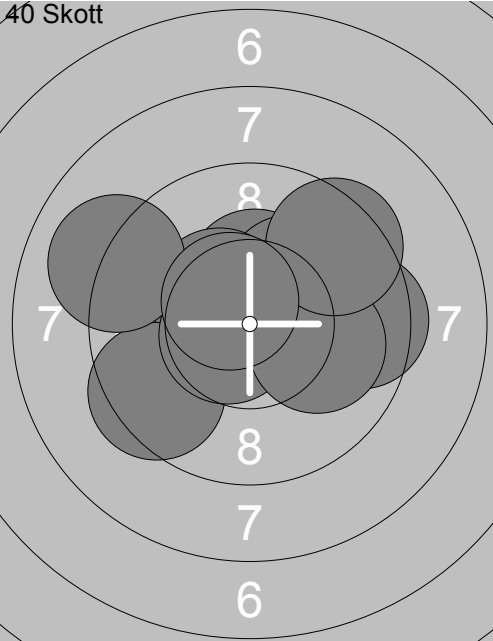
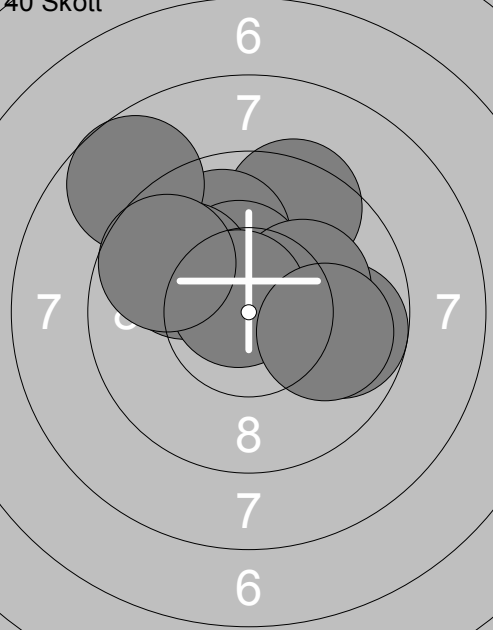
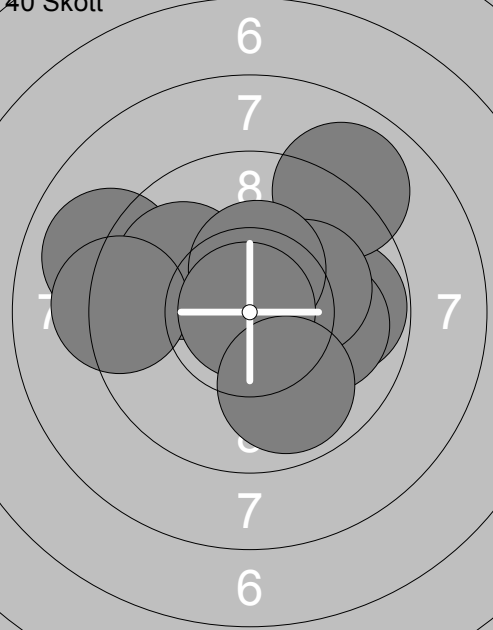
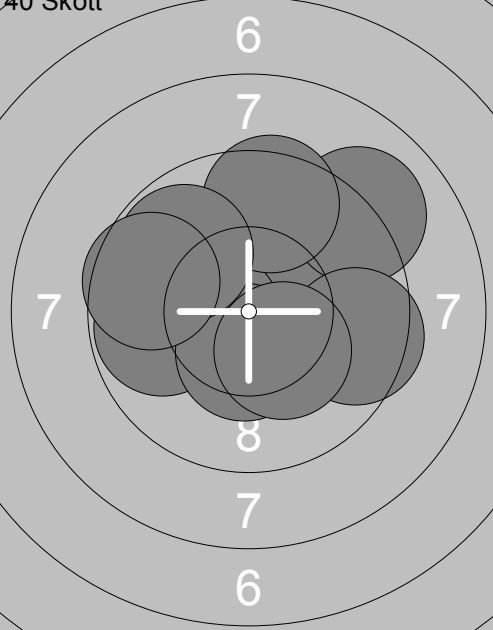
Skjutlag	Tavla	Lina Lindström	
1	22		
Vindeln	Gefle Frivilliga Skarp		Gä
18.03.2017	SM & JSM Luftgevär 2017	Ramselefors SKF	
Prov 	1: 10.4✕ 2: 9.5 → 3: 10.7✕ 4: 9.9 → 5: 10.8x➤ 6: 8.7 → 7: 8.9 ↗ 8: 9.9 → Serie 78.8 Total 0.0	40 Skott 	1: 10.3x↗ 2: 9.5 → 3: 10.2x↗ 4: 10.4✕ 5: 9.5 ↙ 6: 10.6✕ 7: 9.0 ↙ 8: 10.0 ➤ 9: 9.5 ↗ 10: 10.6✕ Serie 99.6 Total 99.6
40 Skott 	11: 9.5 ↗ 12: 9.9 ↗ 13: 8.7 ↙ 14: 10.4x↗ 15: 9.7 → 16: 10.2x➤ 17: 10.0 ↙ 18: 10.7x✕ 19: 9.9 ➤ 20: 9.7 ↙ Serie 98.7 Total 198.3	40 Skott 	21: 9.0 ↙ 22: 9.8 → 23: 9.9 ↙ 24: 9.0 ↗ 25: 10.0 ➤ 26: 10.2x➤ 27: 10.4x↗ 28: 9.3 ↙ 29: 10.9✕ 30: 9.9 ↘ Serie 98.4 Total 296.7
40 Skott 	31: 10.2x↗ 32: 10.5✕ 33: 9.8 ↙ 34: 9.1 ↗ 35: 9.5 ↗ 36: 9.5 → 37: 10.4x↘ 38: 10.3x↘ 39: 9.8 ↙ 40: 9.6 ↙ Serie 98.7 Total 395.4		

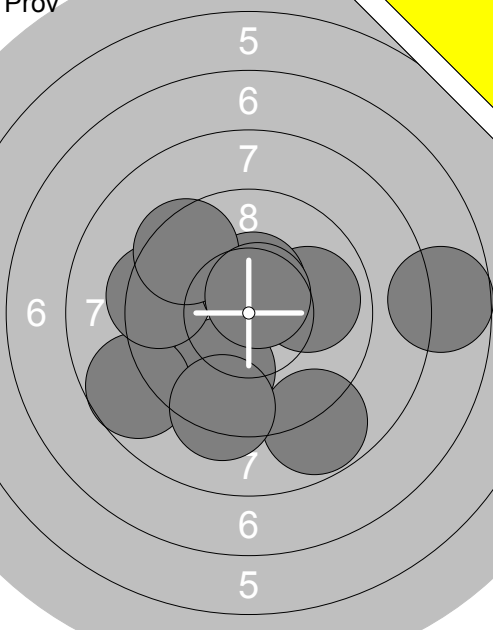
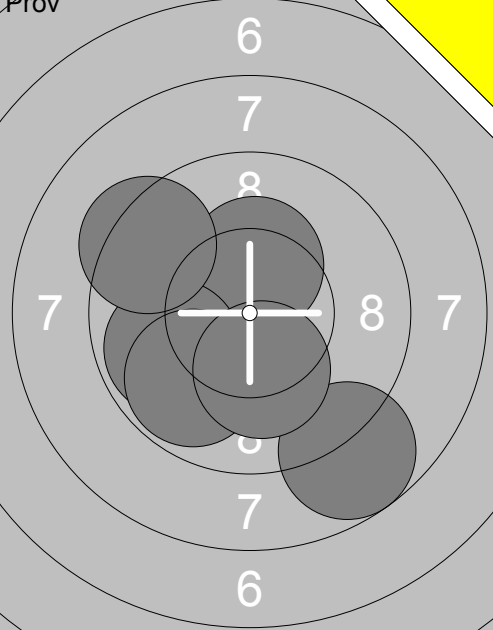
	<p>Prov</p> <p>1: 9.9 ↘ 2: 8.7 ↙ 3: 8.8 ↘ 4: 9.3 ↘ 5: 9.4 ← 6: 9.9 → 7: 7.7 → 8: 10.5x↗ 9: 9.5 ↖ 10: 10.6x↗</p> <p>Serie 94.3 Total 0.0</p>		<p>Prov</p> <p>11: 10.3x↗ 12: 9.8 ↙ 13: 8.8 ↘ 14: 9.8 ↘ 15: 10.2x↘ 16: 9.4 ↖</p> <p>Serie 58.3 Total 0.0</p>
--	---	--	--

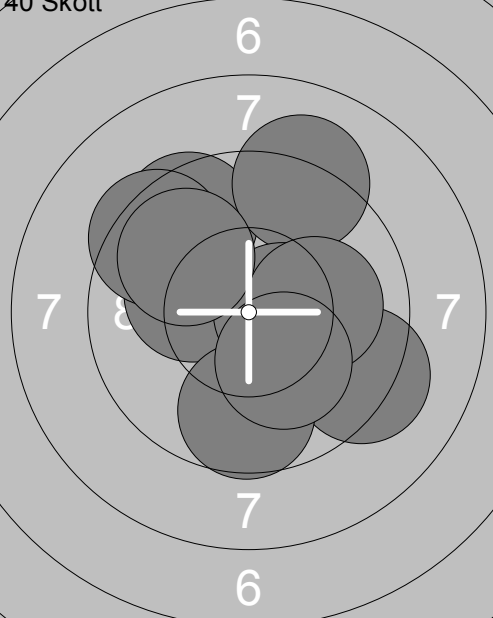
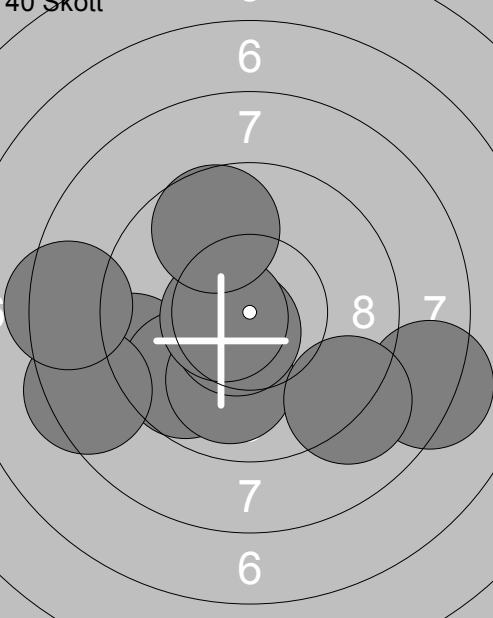
<p>40 Skott</p> 	<p>1: 10.2x↖ 2: 9.5 ↗ 3: 9.3 ↘ 4: 9.4 ↖ 5: 9.7 ↘ 6: 9.1 ↗ 7: 10.5x→ 8: 10.1→ 9: 10.2x↘ 10: 9.9 ↖</p> <p>Serie 97.9 Total 97.9</p>	<p>40 Skott</p> 	<p>11: 9.2 ↙ 12: 9.7 ↘ 13: 10.0 ↘ 14: 8.2 → 15: 8.4 ↙ 16: 9.1 ↘ 17: 10.6x↘ 18: 10.6x↖ 19: 9.7 ↗ 20: 8.4 ←</p> <p>Serie 93.9 Total 191.8</p>
---	---	---	---

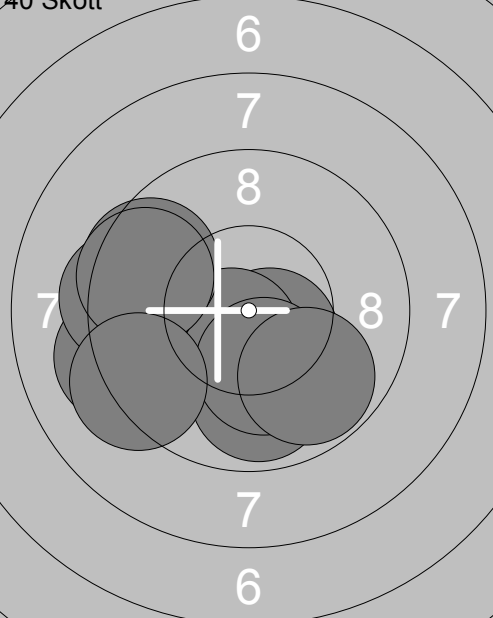
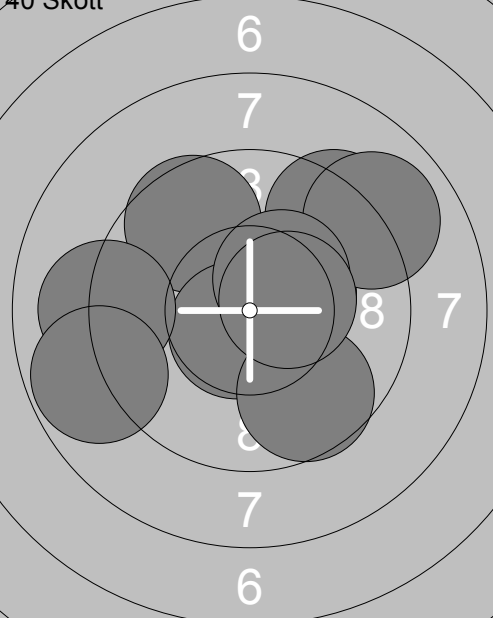
<p>40 Skott</p> 	<p>21: 10.5x↘ 22: 9.2 ↙ 23: 10.5x↘ 24: 9.5 ↙ 25: 9.9 ↘ 26: 10.2x↘ 27: 9.4 ↙ 28: 9.5 ↙ 29: 9.8 ↘ 30: 9.2 ↙</p> <p>Serie 97.7 Total 289.5</p>	<p>40 Skott</p> 	<p>31: 10.4x→ 32: 9.6 ↖ 33: 10.6x↘ 34: 9.3 ↗ 35: 9.6 ↘ 36: 9.1 ← 37: 9.0 ↗ 38: 8.8 ↙ 39: 10.4x↗ 40: 10.4x→</p> <p>Serie 97.2 Total 386.7</p>
--	---	--	--

Skjutlag	Tavla	Miranda Karlsson	
1	24		
Vindeln	Gällivare		No
18.03.2017	SM & JSM Luftgevär 2017	Ramselefors SKF	
	1: 9.9 ↓ 2: 9.3 → 3: 9.1 ↙ 4: 10.1 ↗ 5: 10.3x↗ 6: 9.0 → 7: 10.2x↗ 8: 9.9 → 9: 10.3x↗ 10: 10.4x↗ Serie 98.5 Total 0.0		11: 10.1 ↗ Serie 10.1 Total 0.0
	1: 10.5x↓ 2: 10.0 ↗ 3: 10.1 ↓ 4: 9.8 ↓ 5: 10.7x↖ 6: 10.6x↗ 7: 10.3x↑ 8: 10.1 ↓ 9: 9.2 ↑ 10: 9.8 ↗ Serie 101.1 Total 101.1		11: 10.5x↗ 12: 9.5 ↗ 13: 9.8 → 14: 9.9 ↖ 15: 9.8 ↗ 16: 9.9 ↖ 17: 10.2x↖ 18: 10.1 ↖ 19: 10.1 ↖ 20: 7.5 → Serie 97.3 Total 198.4
	21: 9.3 ↗ 22: 9.3 ↖ 23: 8.1 ↗ 24: 9.9 ↓ 25: 9.8 ↑ 26: 9.2 → 27: 10.7x→ 28: 8.9 ↖ 29: 8.9 ↗ 30: 9.9 ↑ Serie 94.0 Total 292.4		31: 8.7 → 32: 9.7 ↖ 33: 10.0 → 34: 10.5x↗ 35: 9.4 ↖ 36: 8.8 ↖ 37: 8.8 ↗ 38: 10.0 ↗ 39: 9.9 → 40: 8.8 ↑ Serie 94.6 Total 387.0

<p>Prov</p>	<p>1: 8.8 ↙ 2: 9.9 ↗ 3: 10.5x ↘ 4: 9.3 ↓ 5: 10.3x ↘ 6: 8.7 ← 7: 7.5 ↙ 8: 10.8x ↘ 9: 9.1 ↓ 10: 8.4 ↓</p> <p>Serie 93.3 Total 0.0</p>	<p>Prov</p>	<p>11: 9.1 ← 12: 10.0 → 13: 9.7 ↙ 14: 9.6 ← 15: 9.5 ↗ 16: 9.5 → 17: 7.6 ↓ 18: 8.6 ↙ 19: 10.0 ↓</p> <p>Serie 83.6 Total 0.0</p>
-------------	---	-------------	--

<p>40 Skott</p>	<p>1: 7.3 ← 2: 10.6x ↘ 3: 10.1 ↓ 4: 8.5 ↙ 5: 8.8 ← 6: 9.2 ↗ 7: 9.3 ↗ 8: 10.3x ↗ 9: 10.3x ↗ 10: 9.8 ↓</p> <p>Serie 94.2 Total 94.2</p>	<p>40 Skott</p>	<p>11: 9.9 ← 12: 10.0 → 13: 10.9x ↓ 14: 8.3 → 15: 9.4 ↗ 16: 10.4x → 17: 10.0 → 18: 9.4 ↗ 19: 9.8 ↗ 20: 9.4 →</p> <p>Serie 97.5 Total 191.7</p>
-----------------	---	-----------------	--

<p>40 Skott</p>	<p>21: 9.6 ↑ 22: 9.8 ↗ 23: 8.7 ↘ 24: 10.0 ← 25: 10.4x ↘ 26: 10.3x ↓ 27: 10.6x ↘ 28: 10.3x ↓ 29: 10.3x ↘ 30: 9.1 →</p> <p>Serie 99.1 Total 290.8</p>	<p>40 Skott</p>	<p>31: 8.5 ↓ 32: 9.8 → 33: 10.3x ↓ 34: 10.2x ↗ 35: 9.8 ↓ 36: 9.4 → 37: 9.7 ↑ 38: 9.2 ↙ 39: 10.4x ↗ 40: 9.8 ↗</p> <p>Serie 97.1 Total 387.9</p>
-----------------	---	-----------------	--

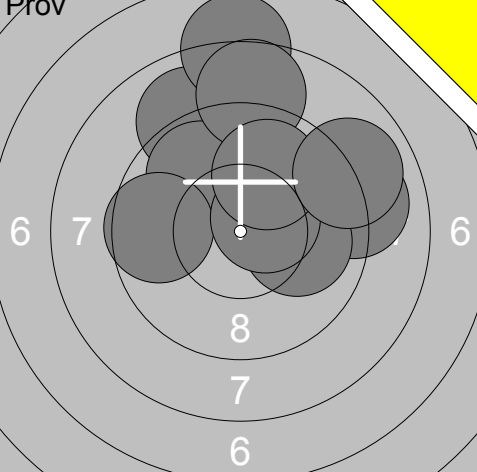
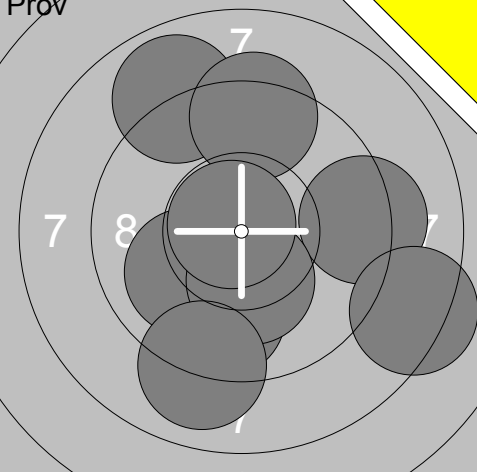
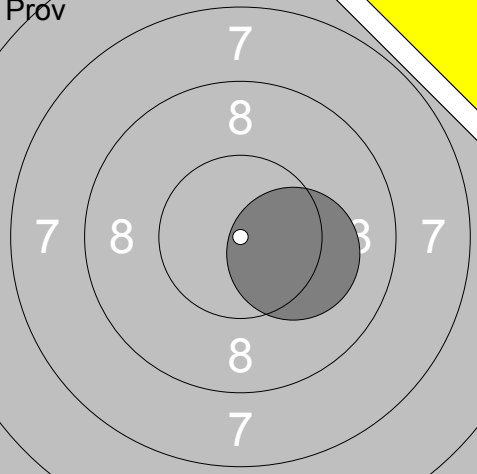
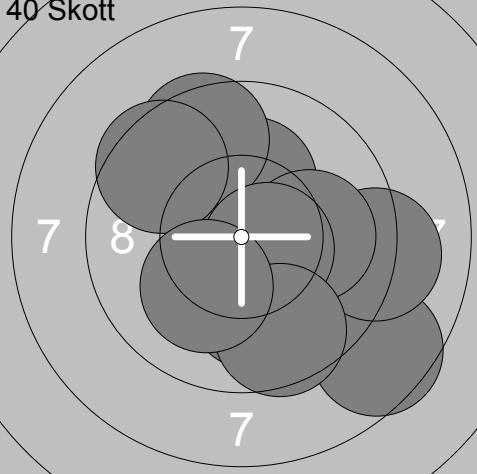
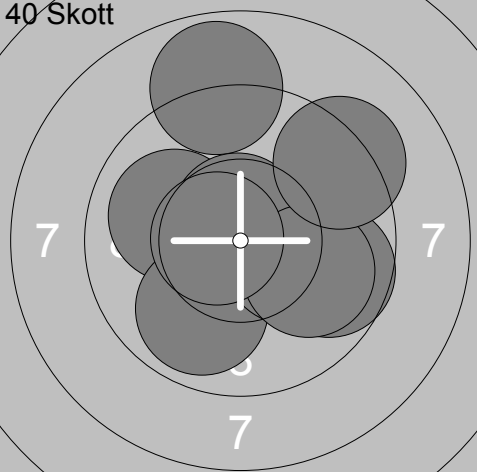
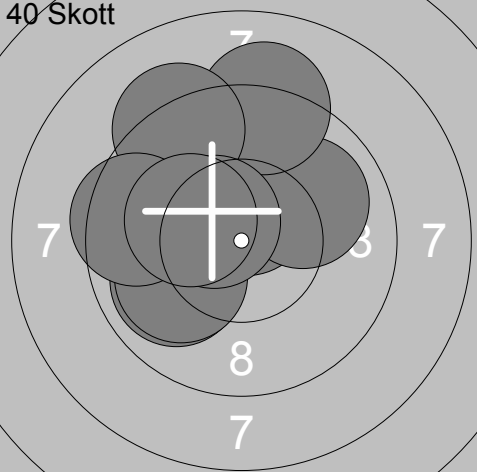
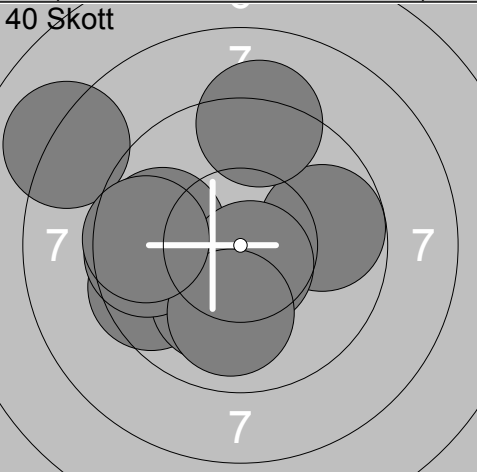
<p>Prov</p> 	<table border="1" style="width:100%; border-collapse: collapse;"> <tr><td>1:</td><td>9.0</td><td>→</td></tr> <tr><td>2:</td><td>9.0</td><td>↗</td></tr> <tr><td>3:</td><td>9.8</td><td>↗</td></tr> <tr><td>4:</td><td>8.0</td><td>↑</td></tr> <tr><td>5:</td><td>10.0</td><td>→</td></tr> <tr><td>6:</td><td>8.7</td><td>↑</td></tr> <tr><td>7:</td><td>9.6</td><td>←</td></tr> <tr><td>8:</td><td>10.5x</td><td>↗</td></tr> <tr><td>9:</td><td>9.9</td><td>↗</td></tr> <tr><td>10:</td><td>8.9</td><td>↗</td></tr> <tr><td colspan="2">Serie</td><td>93.4</td></tr> <tr><td colspan="2">Total</td><td>0.0</td></tr> </table>	1:	9.0	→	2:	9.0	↗	3:	9.8	↗	4:	8.0	↑	5:	10.0	→	6:	8.7	↑	7:	9.6	←	8:	10.5x	↗	9:	9.9	↗	10:	8.9	↗	Serie		93.4	Total		0.0	<p>Prov</p> 	<table border="1" style="width:100%; border-collapse: collapse;"> <tr><td>11:</td><td>8.9</td><td>↗</td></tr> <tr><td>12:</td><td>9.8</td><td>↓</td></tr> <tr><td>13:</td><td>9.3</td><td>↑</td></tr> <tr><td>14:</td><td>10.2x</td><td>↙</td></tr> <tr><td>15:</td><td>10.0</td><td>↙</td></tr> <tr><td>16:</td><td>9.2</td><td>→</td></tr> <tr><td>17:</td><td>10.3x</td><td>↓</td></tr> <tr><td>18:</td><td>9.0</td><td>↓</td></tr> <tr><td>19:</td><td>8.3</td><td>→</td></tr> <tr><td>20:</td><td>10.8x</td><td>↗</td></tr> <tr><td colspan="2">Serie</td><td>95.8</td></tr> <tr><td colspan="2">Total</td><td>0.0</td></tr> </table>	11:	8.9	↗	12:	9.8	↓	13:	9.3	↑	14:	10.2x	↙	15:	10.0	↙	16:	9.2	→	17:	10.3x	↓	18:	9.0	↓	19:	8.3	→	20:	10.8x	↗	Serie		95.8	Total		0.0
1:	9.0	→																																																																									
2:	9.0	↗																																																																									
3:	9.8	↗																																																																									
4:	8.0	↑																																																																									
5:	10.0	→																																																																									
6:	8.7	↑																																																																									
7:	9.6	←																																																																									
8:	10.5x	↗																																																																									
9:	9.9	↗																																																																									
10:	8.9	↗																																																																									
Serie		93.4																																																																									
Total		0.0																																																																									
11:	8.9	↗																																																																									
12:	9.8	↓																																																																									
13:	9.3	↑																																																																									
14:	10.2x	↙																																																																									
15:	10.0	↙																																																																									
16:	9.2	→																																																																									
17:	10.3x	↓																																																																									
18:	9.0	↓																																																																									
19:	8.3	→																																																																									
20:	10.8x	↗																																																																									
Serie		95.8																																																																									
Total		0.0																																																																									
<p>Prov</p> 	<table border="1" style="width:100%; border-collapse: collapse;"> <tr><td>21:</td><td>10.2x</td><td>→</td></tr> <tr><td colspan="2">Serie</td><td>10.2</td></tr> <tr><td colspan="2">Total</td><td>0.0</td></tr> </table>	21:	10.2x	→	Serie		10.2	Total		0.0	<p>40 Skott</p> 	<table border="1" style="width:100%; border-collapse: collapse;"> <tr><td>1:</td><td>10.2x</td><td>↑</td></tr> <tr><td>2:</td><td>10.0</td><td>↓</td></tr> <tr><td>3:</td><td>8.6</td><td>↓</td></tr> <tr><td>4:</td><td>9.1</td><td>→</td></tr> <tr><td>5:</td><td>9.5</td><td>↗</td></tr> <tr><td>6:</td><td>10.0</td><td>→</td></tr> <tr><td>7:</td><td>9.5</td><td>↗</td></tr> <tr><td>8:</td><td>10.6x</td><td>→</td></tr> <tr><td>9:</td><td>9.6</td><td>↓</td></tr> <tr><td>10:</td><td>10.1</td><td>↙</td></tr> <tr><td colspan="2">Serie</td><td>97.2</td></tr> <tr><td colspan="2">Total</td><td>97.2</td></tr> </table>	1:	10.2x	↑	2:	10.0	↓	3:	8.6	↓	4:	9.1	→	5:	9.5	↗	6:	10.0	→	7:	9.5	↗	8:	10.6x	→	9:	9.6	↓	10:	10.1	↙	Serie		97.2	Total		97.2																											
21:	10.2x	→																																																																									
Serie		10.2																																																																									
Total		0.0																																																																									
1:	10.2x	↑																																																																									
2:	10.0	↓																																																																									
3:	8.6	↓																																																																									
4:	9.1	→																																																																									
5:	9.5	↗																																																																									
6:	10.0	→																																																																									
7:	9.5	↗																																																																									
8:	10.6x	→																																																																									
9:	9.6	↓																																																																									
10:	10.1	↙																																																																									
Serie		97.2																																																																									
Total		97.2																																																																									
<p>40 Skott</p> 	<table border="1" style="width:100%; border-collapse: collapse;"> <tr><td>11:</td><td>10.0</td><td>←</td></tr> <tr><td>12:</td><td>9.9</td><td>↙</td></tr> <tr><td>13:</td><td>10.2x</td><td>→</td></tr> <tr><td>14:</td><td>8.9</td><td>↑</td></tr> <tr><td>15:</td><td>10.2x</td><td>→</td></tr> <tr><td>16:</td><td>10.7x</td><td>↑</td></tr> <tr><td>17:</td><td>9.7</td><td>→</td></tr> <tr><td>18:</td><td>9.9</td><td>→</td></tr> <tr><td>19:</td><td>9.2</td><td>↗</td></tr> <tr><td>20:</td><td>10.6x</td><td>←</td></tr> <tr><td colspan="2">Serie</td><td>99.3</td></tr> <tr><td colspan="2">Total</td><td>196.5</td></tr> </table>	11:	10.0	←	12:	9.9	↙	13:	10.2x	→	14:	8.9	↑	15:	10.2x	→	16:	10.7x	↑	17:	9.7	→	18:	9.9	→	19:	9.2	↗	20:	10.6x	←	Serie		99.3	Total		196.5	<p>40 Skott</p> 	<table border="1" style="width:100%; border-collapse: collapse;"> <tr><td>21:</td><td>9.7</td><td>↗</td></tr> <tr><td>22:</td><td>9.9</td><td>←</td></tr> <tr><td>23:</td><td>10.5x</td><td>↑</td></tr> <tr><td>24:</td><td>10.0</td><td>↗</td></tr> <tr><td>25:</td><td>9.1</td><td>↑</td></tr> <tr><td>26:</td><td>9.2</td><td>↗</td></tr> <tr><td>27:</td><td>10.0</td><td>←</td></tr> <tr><td>28:</td><td>10.5x</td><td>↗</td></tr> <tr><td>29:</td><td>9.5</td><td>←</td></tr> <tr><td>30:</td><td>10.2x</td><td>↗</td></tr> <tr><td colspan="2">Serie</td><td>98.6</td></tr> <tr><td colspan="2">Total</td><td>295.1</td></tr> </table>	21:	9.7	↗	22:	9.9	←	23:	10.5x	↑	24:	10.0	↗	25:	9.1	↑	26:	9.2	↗	27:	10.0	←	28:	10.5x	↗	29:	9.5	←	30:	10.2x	↗	Serie		98.6	Total		295.1
11:	10.0	←																																																																									
12:	9.9	↙																																																																									
13:	10.2x	→																																																																									
14:	8.9	↑																																																																									
15:	10.2x	→																																																																									
16:	10.7x	↑																																																																									
17:	9.7	→																																																																									
18:	9.9	→																																																																									
19:	9.2	↗																																																																									
20:	10.6x	←																																																																									
Serie		99.3																																																																									
Total		196.5																																																																									
21:	9.7	↗																																																																									
22:	9.9	←																																																																									
23:	10.5x	↑																																																																									
24:	10.0	↗																																																																									
25:	9.1	↑																																																																									
26:	9.2	↗																																																																									
27:	10.0	←																																																																									
28:	10.5x	↗																																																																									
29:	9.5	←																																																																									
30:	10.2x	↗																																																																									
Serie		98.6																																																																									
Total		295.1																																																																									
<p>40 Skott</p> 	<table border="1" style="width:100%; border-collapse: collapse;"> <tr><td>31:</td><td>9.5</td><td>←</td></tr> <tr><td>32:</td><td>9.8</td><td>→</td></tr> <tr><td>33:</td><td>9.2</td><td>↑</td></tr> <tr><td>34:</td><td>10.1</td><td>↙</td></tr> <tr><td>35:</td><td>8.1</td><td>↗</td></tr> <tr><td>36:</td><td>9.8</td><td>←</td></tr> <tr><td>37:</td><td>10.6x</td><td>↓</td></tr> <tr><td>38:</td><td>9.6</td><td>←</td></tr> <tr><td>39:</td><td>10.0</td><td>↓</td></tr> <tr><td>40:</td><td>9.6</td><td>←</td></tr> <tr><td colspan="2">Serie</td><td>96.3</td></tr> <tr><td colspan="2">Total</td><td>391.4</td></tr> </table>	31:	9.5	←	32:	9.8	→	33:	9.2	↑	34:	10.1	↙	35:	8.1	↗	36:	9.8	←	37:	10.6x	↓	38:	9.6	←	39:	10.0	↓	40:	9.6	←	Serie		96.3	Total		391.4																																						
31:	9.5	←																																																																									
32:	9.8	→																																																																									
33:	9.2	↑																																																																									
34:	10.1	↙																																																																									
35:	8.1	↗																																																																									
36:	9.8	←																																																																									
37:	10.6x	↓																																																																									
38:	9.6	←																																																																									
39:	10.0	↓																																																																									
40:	9.6	←																																																																									
Serie		96.3																																																																									
Total		391.4																																																																									

	1: 8.7 ↖ 2: 9.7 → 3: 8.7 ↖ 4: 10.1 ← 5: 10.2 ✕ 6: 8.6 → 7: 9.8 ↘ 8: 9.7 ↗ 9: 9.5 ↘ 10: 8.6 →		11: 10.6x ↗ 12: 9.5 ↗ 13: 10.6x ↗ 14: 10.3x ↗ 15: 8.5 ← 16: 10.2x ↗ 17: 9.5 ↖
	Serie 93.6 Total 0.0		Serie 69.2 Total 0.0

	1: 9.2 ↗ 2: 9.3 → 3: 8.7 ↗ 4: 9.6 ↗ 5: 7.6 → 6: 8.9 ← 7: 9.1 ↖ 8: 10.0 ↖ 9: 8.9 → 10: 8.9 ↗		11: 8.9 → 12: 10.2x ↘ 13: 10.1 ↗ 14: 9.5 ↖ 15: 8.6 → 16: 9.4 → 17: 10.6x ↗ 18: 10.0 → 19: 10.2x ↗ 20: 9.2 ↖
	Serie 90.2 Total 90.2		Serie 96.7 Total 186.9

	21: 9.9 ↗ 22: 9.6 ↖ 23: 8.7 ↖ 24: 10.1 ↗ 25: 10.5x ↘ 26: 10.3x ↗ 27: 9.4 ↗ 28: 8.6 ↖ 29: 9.0 → 30: 9.7 ↗		31: 10.0 ↗ 32: 9.4 ↗ 33: 8.6 ↖ 34: 10.4x ↗ 35: 10.3x ✕ 36: 9.4 ↗ 37: 10.6x ↘ 38: 9.1 ↘ 39: 9.0 ↖ 40: 10.3x ✕
	Serie 95.8 Total 282.7		Serie 97.1 Total 379.8

<p>Prov</p>	<p>1: 10.3x ↗                  2: 9.5 ↖                  3: 9.2 ←                  4: 8.9 ←                  5: 9.5 ↗                  6: 9.9 ↖                  7: 9.3 ↗                  8: 10.1 ↗                  9: 10.4x ↗                  10: 10.6x ↗</p> <p>Serie 97.7                  Total 0.0</p>	<p>Prov</p>	<p>11: 9.8 ↖                  12: 9.6 ↗                  13: 9.9 ←                  14: 10.9x ↖                  15: 10.1 ↖                  16: 10.5x ↖                  17: 9.8 ←                  18: 10.2x ↖                  19: 10.4x ↖                  20: 9.8 ←</p> <p>Serie 101.0                  Total 0.0</p>
<p>40 Skott</p>	<p>1: 10.3x ↗                  2: 8.2 ↖                  3: 10.3x ↖                  4: 10.3x ↖                  5: 10.8x ↗                  6: 10.0 ↖                  7: 9.7 ↘                  8: 9.9 ↗                  9: 10.3x ↗                  10: 9.4 ↗</p> <p>Serie 99.2                  Total 99.2</p>	<p>40 Skott</p>	<p>11: 10.3x ↖                  12: 10.0 →                  13: 9.5 →                  14: 8.6 ↘                  15: 10.5x ↘                  16: 10.5x ↖                  17: 10.1 ↘                  18: 10.2x ↖                  19: 9.2 →                  20: 10.1 ↘</p> <p>Serie 99.0                  Total 198.2</p>
<p>40 Skott</p>	<p>21: 10.3x ↗                  22: 10.5x ↗                  23: 9.3 ↘                  24: 10.3x ↗                  25: 10.6x ↘                  26: 9.2 →                  27: 10.4x ↘                  28: 9.4 ↘                  29: 9.8 →                  30: 10.4x ↘</p> <p>Serie 100.2                  Total 298.4</p>	<p>40 Skott</p>	<p>31: 10.3x ↗                  32: 8.9 ↘                  33: 7.5 →                  34: 8.8 ↘                  35: 9.6 ↘                  36: 9.8 →                  37: 9.6 ↘                  38: 10.1 →                  39: 9.9 ↘                  40: 8.7 ↘</p> <p>Serie 93.2                  Total 391.6</p>

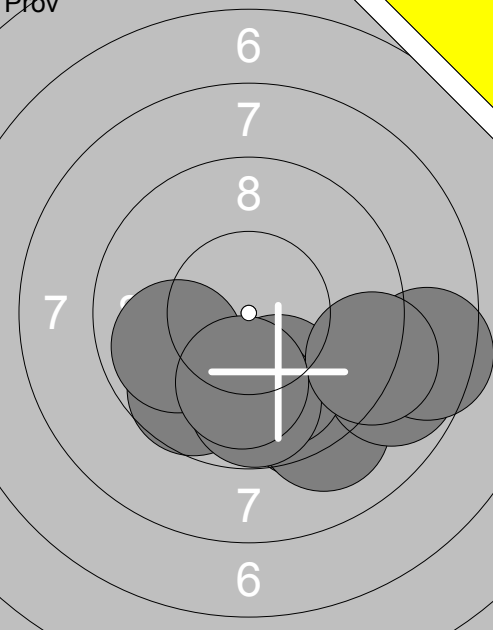
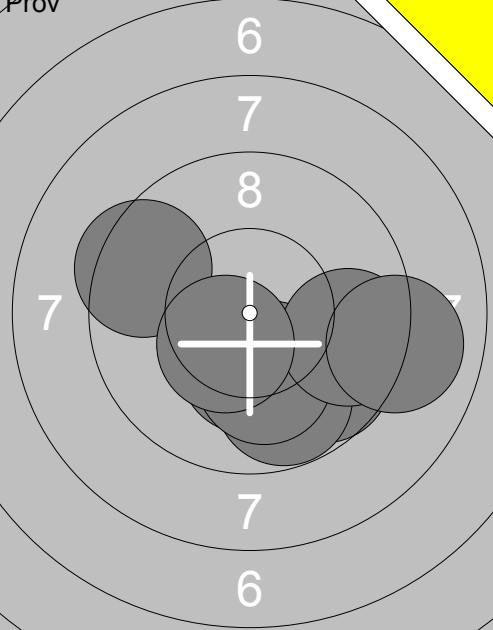
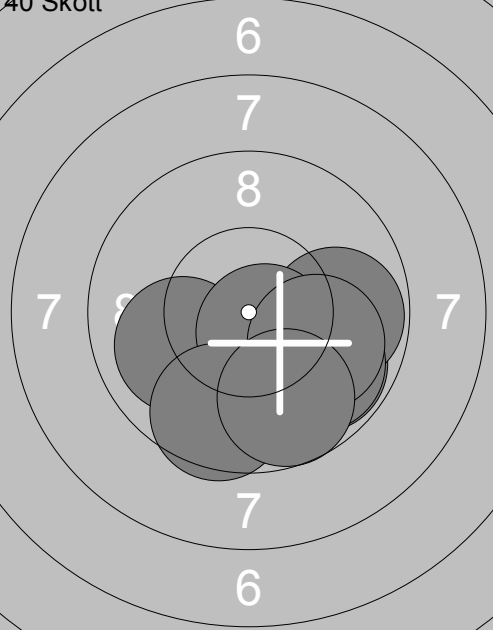
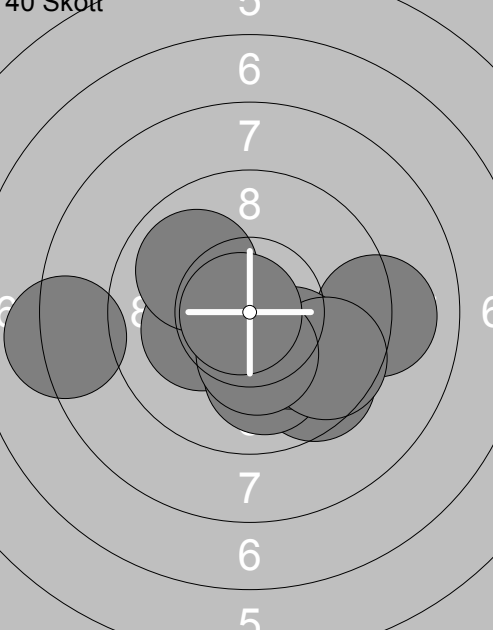
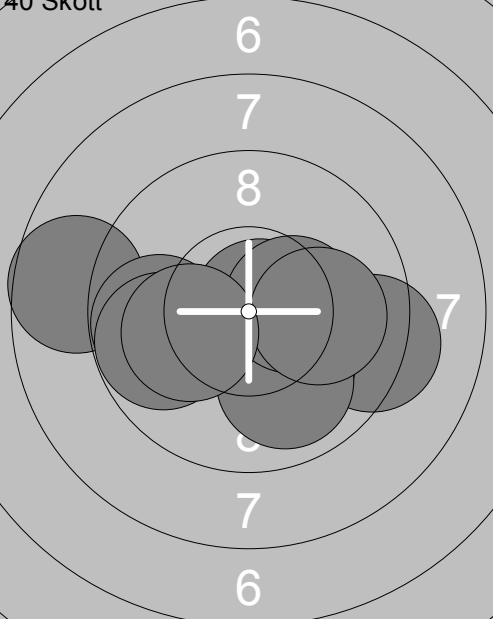
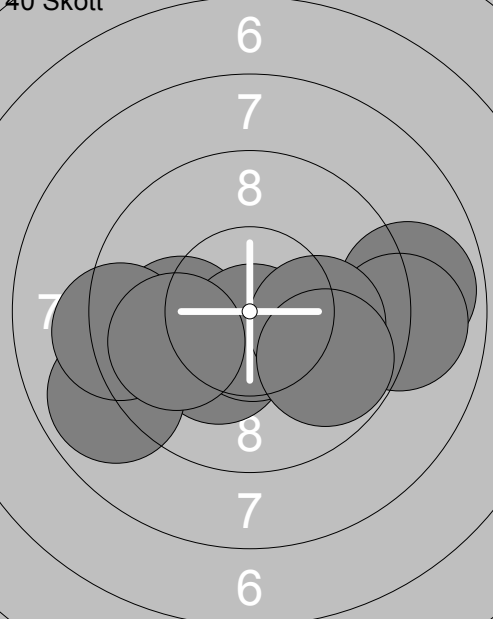

<p>Prov</p> 	<p>1: 9.4 ↘ 2: 9.1 ↘ 3: 8.8 → 4: 8.5 → 5: 9.7 ↘ 6: 10.0 ↘ 7: 9.9 ← 8: 9.8 ↓ 9: 9.2 → 10: 10.0 ↓</p> <p>Serie 94.4 Total 0.0</p>	<p>Prov</p> 	<p>11: 10.3x↓ 12: 9.7 ↘ 13: 10.2x↓ 14: 9.8 ↓ 15: 9.4 ← 16: 10.1 ↓ 17: 9.6 → 18: 10.4x↘ 19: 9.0 →</p> <p>Serie 88.5 Total 0.0</p>
<p>40 Skott</p> 	<p>1: 9.8 ↘ 2: 9.8 → 3: 9.8 ↘ 4: 10.0← 5: 10.0 ↓ 6: 10.3x↘ 7: 10.6x↘ 8: 10.0 → 9: 9.6 ↓ 10: 9.7 ↓</p> <p>Serie 99.6 Total 99.6</p>	<p>40 Skott</p> 	<p>11: 9.6 ↘ 12: 8.2 ← 13: 9.1 → 14: 10.2x← 15: 10.0 ↓ 16: 10.2x↘ 17: 9.6 → 18: 10.3x↓ 19: 10.0 ↖ 20: 10.8x←</p> <p>Serie 98.0 Total 197.6</p>
<p>40 Skott</p> 	<p>21: 8.7 ← 22: 9.8 ← 23: 10.8x→ 24: 9.3 → 25: 10.1 ↓ 26: 9.9 ↓ 27: 9.8 ← 28: 10.4x→ 29: 10.0 → 30: 10.1←</p> <p>Serie 98.9 Total 296.5</p>	<p>40 Skott</p> 	<p>31: 10.0← 32: 8.9 → 33: 9.0 → 34: 10.3x↘ 35: 8.9 ← 36: 9.2 ← 37: 10.7x↓ 38: 10.1 → 39: 9.9 ← 40: 9.8 ↘</p> <p>Serie 96.8 Total 393.3</p>

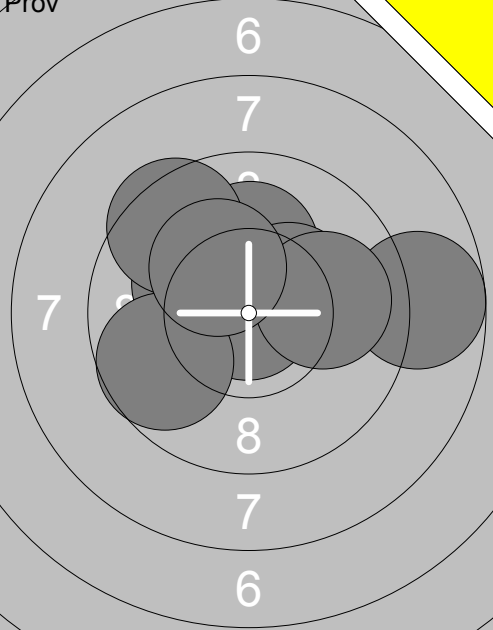
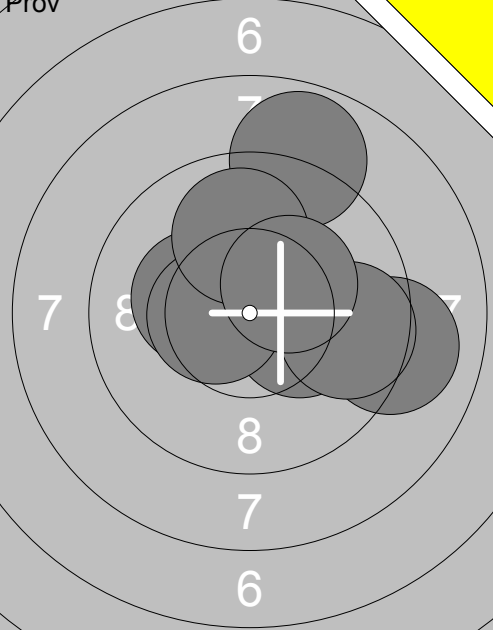
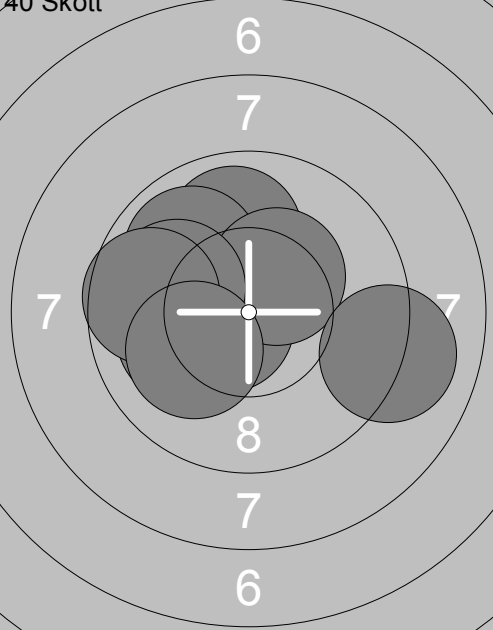
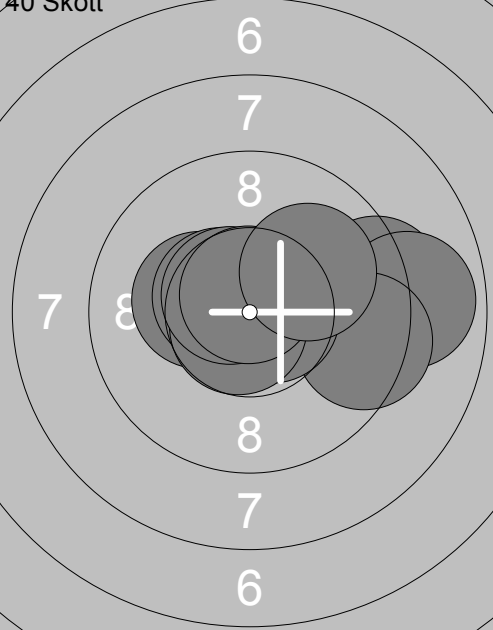
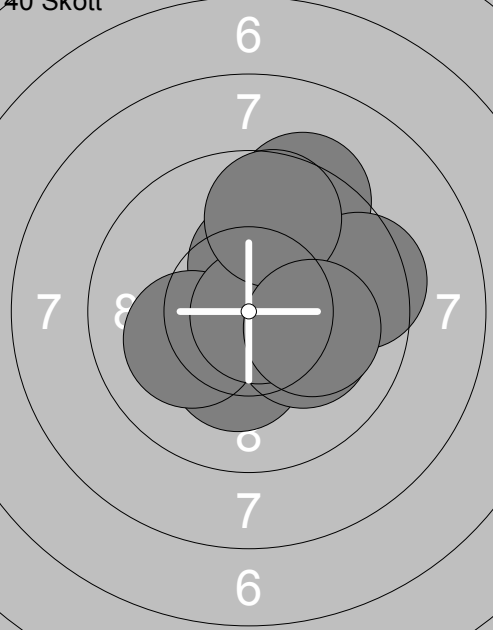
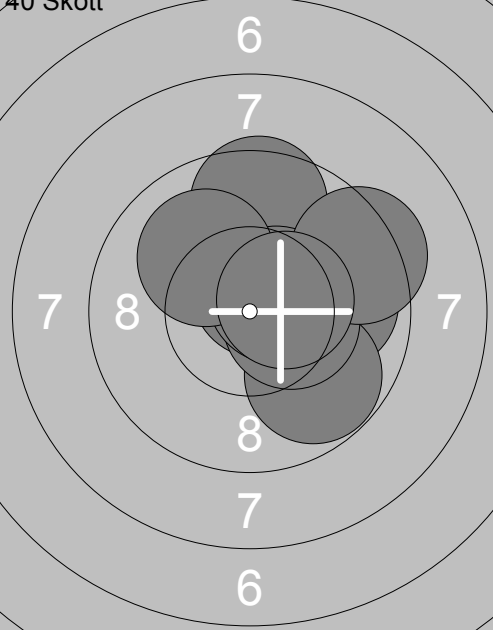
<p>Prov</p> 	<p>1: 10.1 ↑</p> <p>2: 10.7 ↘</p> <p>3: 10.4 ↗</p> <p>4: 8.7 →</p> <p>5: 10.2 ↘</p> <p>6: 10.9 ↘</p> <p>7: 9.7 ↙</p> <p>8: 9.5 ↖</p> <p>9: 10.0 →</p> <p>10: 10.2 ↘</p> <p>Serie 100.4</p> <p>Total 0.0</p>	<p>Prov</p> 	<p>11: 10.3x ➤</p> <p>12: 8.9 ↑</p> <p>13: 10.3 ↘</p> <p>14: 10.5 ↘</p> <p>15: 10.0 ↑</p> <p>16: 9.1 →</p> <p>17: 9.7 →</p> <p>18: 10.3x ↗</p> <p>Serie 79.1</p> <p>Total 0.0</p>
<p>40 Skott</p> 	<p>1: 10.6x ↘</p> <p>2: 9.9 ↑</p> <p>3: 9.9 ↖</p> <p>4: 10.1 ↙</p> <p>5: 10.2x ↘</p> <p>6: 10.4x ↗</p> <p>7: 10.0 ↙</p> <p>8: 9.7 ↙</p> <p>9: 10.1 ↙</p> <p>10: 9.1 →</p> <p>Serie 100.0</p> <p>Total 100.0</p>	<p>40 Skott</p> 	<p>11: 10.3x ↘</p> <p>12: 10.5x ↘</p> <p>13: 9.3 →</p> <p>14: 8.9 →</p> <p>15: 9.4 →</p> <p>16: 10.7x ➤</p> <p>17: 10.7x ↙</p> <p>18: 10.6x ↘</p> <p>19: 10.7x ↑</p> <p>20: 10.0 ↗</p> <p>Serie 101.1</p> <p>Total 201.1</p>
<p>40 Skott</p> 	<p>21: 9.4 ↑</p> <p>22: 10.3x ↙</p> <p>23: 10.3x ↑</p> <p>24: 10.3x ➤</p> <p>25: 10.2x ➤</p> <p>26: 9.5 →</p> <p>27: 10.1 ↙</p> <p>28: 10.8x ➤</p> <p>29: 9.7 ↑</p> <p>30: 10.1 →</p> <p>Serie 100.7</p> <p>Total 301.8</p>	<p>40 Skott</p> 	<p>31: 10.6x ↗</p> <p>32: 10.1 →</p> <p>33: 9.9 →</p> <p>34: 9.6 ↑</p> <p>35: 9.8 ↘</p> <p>36: 10.4x ➤</p> <p>37: 10.5x ↗</p> <p>38: 10.0 ↖</p> <p>39: 9.3 ↗</p> <p>40: 10.5x ➤</p> <p>Serie 100.7</p> <p>Total 402.5</p>

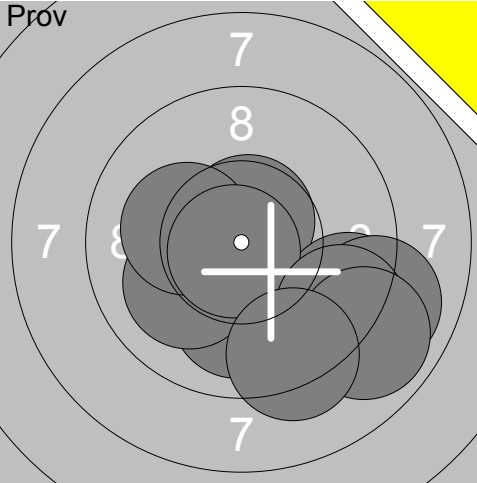
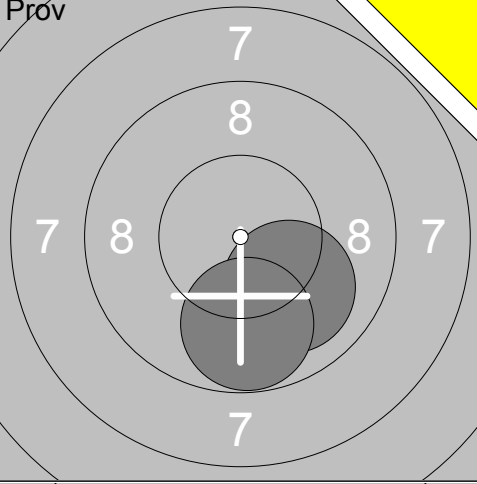
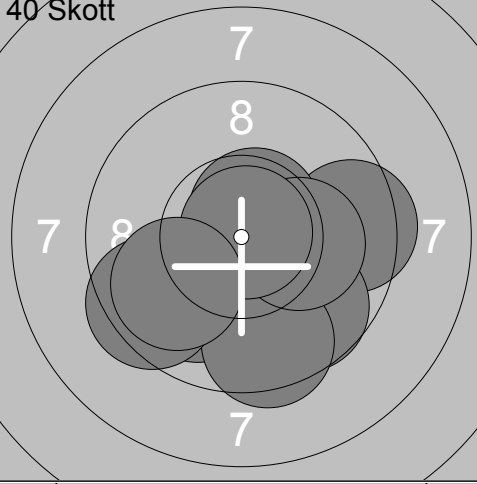
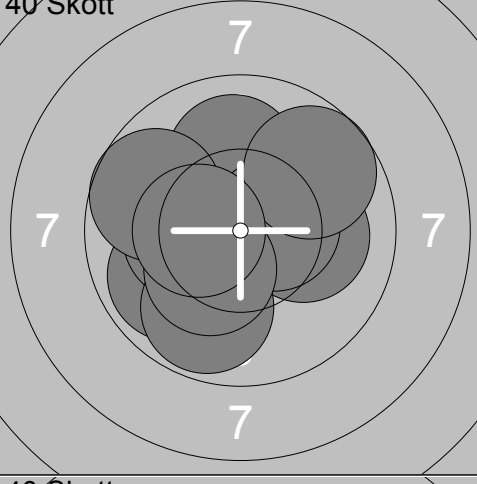
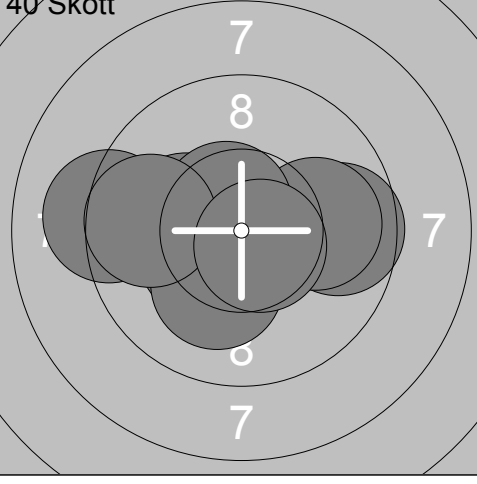
Skjutlag <b>2</b>	Tavla <b>8</b>	<b>Kristina Kjellgren</b>	
Vindeln	Öregrund-Gräsö		Up
18.03.2017	SM & JSM Luftgevär 2017	Ramselefors SKF	
<b>Pröv</b> 	1: 9.7 ↙ 2: 10.2x ↙ 3: 8.9 → 4: 10.7x ↑ 5: 10.6x → 6: 9.7 ← 7: 10.2x ↓ 8: 10.2x ↓ 9: 9.3 ↓ 10: 9.4 ← Serie 98.9 Total 0.0	<b>Pröv</b> 	11: 10.7x ↑ 12: 10.0 ↓ 13: 10.1 ↙ 14: 9.3 → 15: 10.2x ← 16: 9.0 → 17: 10.8x ↙ 18: 9.3 ↓ 19: 8.9 ↓ 20: 9.3 ↓ Serie 97.6 Total 0.0
<b>Pröv</b> 	21: 10.0 ↓ 22: 9.8 ↓ Serie 19.8 Total 0.0	<b>40 Skott</b> 	1: 10.0 ↙ 2: 10.3x ↙ 3: 9.5 → 4: 10.6x ↑ 5: 9.7 ↓ 6: 9.5 ↓ 7: 9.5 ↙ 8: 10.2x → 9: 10.9x ↗ 10: 9.9 ↙ Serie 100.1 Total 100.1
<b>40 Skott</b> 	11: 10.0 ↑ 12: 10.1 → 13: 10.5x → 14: 9.9 ↙ 15: 10.3x ← 16: 9.8 ↓ 17: 9.7 ↗ 18: 10.3x ↙ 19: 9.7 ↗ 20: 10.4x ← Serie 100.7 Total 200.8	<b>40 Skott</b> 	21: 10.3x ← 22: 9.2 ← 23: 10.4x ↙ 24: 10.2x ← 25: 10.2x ↓ 26: 9.6 → 27: 10.0 → 28: 10.6x ↗ 29: 9.7 ← 30: 10.6x ↙ Serie 100.8 Total 301.6
<b>40 Skott</b> 	31: 9.2 ↓ 32: 10.4x ↙ 33: 9.7 ↙ 34: 9.3 ↙ 35: 10.0 ↗ 36: 9.3 ↓ 37: 9.8 ↓ 38: 9.9 ↙ 39: 10.0 ← 40: 9.9 → Serie 97.5 Total 399.1		

<p>Prov</p>	<p>1: 10.1 ↑</p> <p>2: 9.3 ←</p> <p>3: 8.8 ←</p> <p>4: 9.0 ↖</p> <p>5: 10.3x↓</p> <p>6: 9.5 →</p> <p>7: 10.5x↗</p> <p>8: 10.6x↘</p> <p>9: 10.6x↘</p> <p>10: 10.5x↗</p> <p>Serie 99.2</p> <p>Total 0.0</p>	<p>Prov</p>	<p>11: 10.6x↘</p> <p>12: 9.3 →</p> <p>13: 10.1 ↓</p> <p>14: 10.2x↘</p> <p>Serie 40.2</p> <p>Total 0.0</p>
<p>40 Skott</p>	<p>1: 9.6 ↑</p> <p>2: 9.4 →</p> <p>3: 10.3x↘</p> <p>4: 8.9 →</p> <p>5: 8.3 ↗</p> <p>6: 10.1 ↘</p> <p>7: 10.3x↓</p> <p>8: 10.4x↗</p> <p>9: 8.9 ↑</p> <p>10: 10.0 →</p> <p>Serie 96.2</p> <p>Total 96.2</p>	<p>40 Skott</p>	<p>11: 9.9 ↖</p> <p>12: 10.4x↗</p> <p>13: 10.3x↗</p> <p>14: 10.0 ↖</p> <p>15: 10.8x↖</p> <p>16: 10.6x↓</p> <p>17: 9.8 ←</p> <p>18: 9.9 ↑</p> <p>19: 10.0 →</p> <p>20: 10.2x↖</p> <p>Serie 101.9</p> <p>Total 198.1</p>
<p>40 Skott</p>	<p>21: 9.1 ↗</p> <p>22: 10.0 →</p> <p>23: 8.9 ←</p> <p>24: 10.2x↘</p> <p>25: 10.4x↖</p> <p>26: 10.3x↗</p> <p>27: 10.6x↖</p> <p>28: 9.2 →</p> <p>29: 9.7 ↖</p> <p>30: 10.2x↗</p> <p>Serie 98.6</p> <p>Total 296.7</p>	<p>40 Skott</p>	<p>31: 10.1 ↑</p> <p>32: 9.5 →</p> <p>33: 10.4x↓</p> <p>34: 10.3x↖</p> <p>35: 10.2x↗</p> <p>36: 10.7x↖</p> <p>37: 10.3x↘</p> <p>38: 9.2 →</p> <p>39: 10.2x↖</p> <p>40: 10.6x↗</p> <p>Serie 101.5</p> <p>Total 398.2</p>

<p>Prov</p>	<p>1: 10.6x↘ 2: 10.7x↘ 3: 10.4x↘ 4: 10.1→ 5: 9.8→ 6: 10.4x↘ 7: 8.9↗ 8: 9.7↙ 9: 9.4→ 10: 9.4→</p> <p>Serie 99.4 Total 0.0</p>	<p>Prov</p>	<p>11: 10.3x↘</p> <p>Serie 10.3 Total 0.0</p>
-------------	--	-------------	---

<p>40 Skott</p>	<p>1: 8.5← 2: 10.4x↘ 3: 9.8↗ 4: 9.7↗ 5: 9.9↗ 6: 9.9↗ 7: 10.0↑ 8: 10.3x↗ 9: 10.4x↘ 10: 10.7x→</p> <p>Serie 99.6 Total 99.6</p>	<p>40 Skott</p>	<p>11: 9.8↖ 12: 10.7x↘ 13: 7.6↗ 14: 9.4↘ 15: 8.9↗ 16: 9.8↙ 17: 9.8→ 18: 10.2x↘ 19: 9.2↘ 20: 10.1→</p> <p>Serie 95.5 Total 195.1</p>
-----------------	---	-----------------	---

<p>40 Skott</p>	<p>21: 9.8↙ 22: 10.8x↘ 23: 8.9↗ 24: 10.6x↘ 25: 9.0→ 26: 9.9↘ 27: 8.6↗ 28: 10.7x↘ 29: 10.1↙ 30: 10.0↘</p> <p>Serie 98.4 Total 293.5</p>	<p>40 Skott</p>	<p>31: 8.4↗ 32: 10.2x↗ 33: 9.7↘ 34: 8.6↘ 35: 9.6← 36: 9.4↖ 37: 10.2x↘ 38: 10.5x↗ 39: 9.4← 40: 9.3↖</p> <p>Serie 95.3 Total 388.8</p>
-----------------	--	-----------------	--

Skjuttag	Tavla	Isabella Erkki	
2	11		
Vindeln	Axvall	Vg	
18.03.2017	SM & JSM Luftgevär 2017	Ramselefors SKF	
Prov 	1: 10.0 ↗ 2: 10.5 ✕ 3: 10.2 ✕ 4: 9.9 → 5: 10.9 ↗ 6: 10.3 ✕ 7: 10.3 ✕ 8: 9.8 ↓ 9: 10.8 ✕ 10: 10.1 ↓ Serie 102.8 Total 0.0	Prov 	11: 10.0 ↓ Serie 10.0 Total 0.0
40 Skott 	1: 10.8 ✕ 2: 10.3 ✕ 3: 8.8 ← 4: 9.8 ← 5: 9.9 ↗ 6: 10.7 ✕ 7: 9.0 → 8: 9.7 → 9: 10.7 ✕ 10: 9.8 → Serie 99.5 Total 99.5	40 Skott 	11: 10.2 ✕ 12: 9.8 ↗ 13: 10.7 ✕ 14: 9.9 ↗ 15: 10.6 ✕ 16: 10.0 → 17: 10.4 ✕ 18: 10.8 ✕ 19: 10.3 ✕ 20: 10.6 ✕ Serie 103.3 Total 202.8
40 Skott 	21: 10.3 ✕ 22: 10.1 ↗ 23: 10.6 ✕ 24: 9.3 → 25: 10.4 ✕ 26: 10.5 ✕ 27: 10.2 ✕ 28: 10.1 ↓ 29: 10.2 ✕ 30: 9.9 ← Serie 101.6 Total 304.4	40 Skott 	31: 10.6 ✕ 32: 9.2 → 33: 10.7 ✕ 34: 10.2 ✕ 35: 10.1 ↗ 36: 10.0 ← 37: 9.8 ↗ 38: 9.7 ← 39: 9.8 ← 40: 9.8 ← Serie 99.9 Total 404.3



<p>Prov</p>	<p>1: 10.4x ↘</p> <p>2: 10.6x ↘</p> <p>3: 10.5x ➤</p> <p>4: 9.6 ↖</p> <p>5: 9.1 ↗</p> <p>6: 10.5x ↘</p> <p>7: 9.8 ←</p> <p>8: 10.8x ↘</p> <p>9: 10.1 ↖</p> <p>10: 10.5x ↘</p> <p>Serie 101.9</p> <p>Total 0.0</p>	<p>Prov</p>	<p>11: 9.6 ←</p> <p>12: 10.4x ↗</p> <p>13: 9.8 ↖</p> <p>14: 9.9 ↖</p> <p>15: 9.7 ↗</p> <p>16: 10.2x ↗</p> <p>17: 10.2x ↘</p> <p>18: 10.2x ↘</p> <p>19: 9.9 ←</p> <p>Serie 89.9</p> <p>Total 0.0</p>
<p>40 Skott</p>	<p>1: 10.0 ↓</p> <p>2: 9.7 ↗</p> <p>3: 10.6x ↘</p> <p>4: 9.7 ➔</p> <p>5: 10.1 ➔</p> <p>6: 9.9 ←</p> <p>7: 10.6x ↗</p> <p>8: 10.3x ↘</p> <p>9: 10.7x ↘</p> <p>10: 9.4 ➔</p> <p>Serie 101.0</p> <p>Total 101.0</p>	<p>40 Skott</p>	<p>11: 10.4x ↗</p> <p>12: 8.1 ↑</p> <p>13: 9.7 ↗</p> <p>14: 9.6 ➔</p> <p>15: 9.0 ←</p> <p>16: 10.7x ➤</p> <p>17: 8.5 ↗</p> <p>18: 10.2x ↘</p> <p>19: 10.7x ➤</p> <p>20: 10.5x ↗</p> <p>Serie 97.4</p> <p>Total 198.4</p>
<p>40 Skott</p>	<p>21: 10.0 ↗</p> <p>22: 9.8 ↖</p> <p>23: 10.6x ↘</p> <p>24: 10.4x ↗</p> <p>25: 10.7x ➤</p> <p>26: 10.5x ➤</p> <p>27: 10.2x ↗</p> <p>28: 10.8x ↘</p> <p>29: 9.9 ➤</p> <p>30: 9.8 ↖</p> <p>Serie 102.7</p> <p>Total 301.1</p>	<p>40 Skott</p>	<p>31: 10.3x ➤</p> <p>32: 9.9 ➔</p> <p>33: 10.0 ↓</p> <p>34: 10.8x ↑</p> <p>35: 9.9 ↗</p> <p>36: 9.7 ↗</p> <p>37: 9.8 ↖</p> <p>38: 9.9 ➔</p> <p>39: 10.4x ↗</p> <p>40: 9.7 ←</p> <p>Serie 100.4</p> <p>Total 401.5</p>

<p>Prov</p>	<p>1: 8.0 →</p> <p>2: 9.2 →</p> <p>3: 8.7 →</p> <p>4: 9.3 →</p> <p>5: 8.7 →</p> <p>6: 8.7 →</p> <p>7: 10.5x →</p> <p>8: 10.1 ↓</p> <p>9: 9.1 →</p> <p>10: 10.0 →</p> <p>Serie 92.3</p> <p>Total 0.0</p>	<p>Prov</p>	<p>11: 9.8 →</p> <p>12: 10.3x ↘</p> <p>13: 9.5 →</p> <p>14: 10.5x ↘</p> <p>15: 10.2x ↘</p> <p>16: 10.3x ↘</p> <p>Serie 60.6</p> <p>Total 0.0</p>
-------------	---	-------------	--

<p>40 Skott</p>	<p>1: 10.4x ↘</p> <p>2: 10.3x ↘</p> <p>3: 10.6x ↘</p> <p>4: 8.6 ↗</p> <p>5: 10.4x ↗</p> <p>6: 10.4x ↗</p> <p>7: 10.4x ↗</p> <p>8: 10.8x ↑</p> <p>9: 10.0 ↑</p> <p>10: 9.6 ↗</p> <p>Serie 101.5</p> <p>Total 101.5</p>	<p>40 Skott</p>	<p>11: 10.3x ↘</p> <p>12: 10.2x ↘</p> <p>13: 10.3x ↑</p> <p>14: 9.9 →</p> <p>15: 9.7 ↗</p> <p>16: 10.3x ↑</p> <p>17: 10.0 ↗</p> <p>18: 10.1 →</p> <p>19: 10.0 ↑</p> <p>20: 10.0 ↘</p> <p>Serie 100.8</p> <p>Total 202.3</p>
-----------------	---	-----------------	---

<p>40 Skott</p>	<p>21: 10.3x ↘</p> <p>22: 10.1 ↑</p> <p>23: 9.4 →</p> <p>24: 10.1 ↗</p> <p>25: 10.6x ↘</p> <p>26: 10.3x ↘</p> <p>27: 10.7x ↘</p> <p>28: 10.3x →</p> <p>29: 10.0 ↖</p> <p>30: 9.7 ↑</p> <p>Serie 101.5</p> <p>Total 303.8</p>	<p>40 Skott</p>	<p>31: 10.5x ↘</p> <p>32: 10.3x →</p> <p>33: 10.3x ↘</p> <p>34: 10.2x ↘</p> <p>35: 8.9 ←</p> <p>36: 10.8x ↘</p> <p>37: 10.6x ↘</p> <p>38: 9.5 ←</p> <p>39: 10.4x ↑</p> <p>40: 10.4x ↘</p> <p>Serie 101.9</p> <p>Total 405.7</p>
-----------------	--	-----------------	---

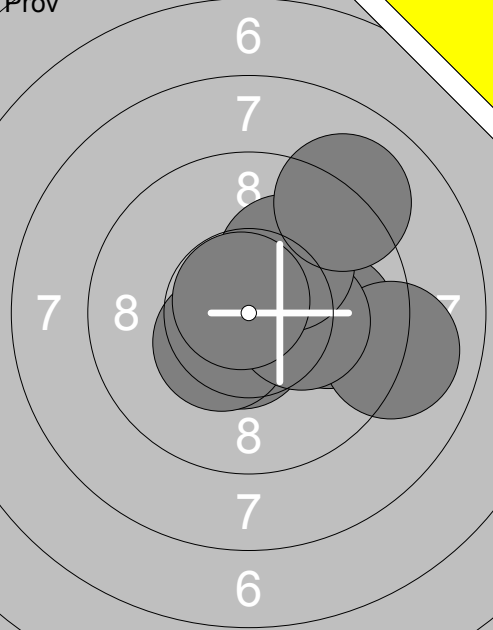

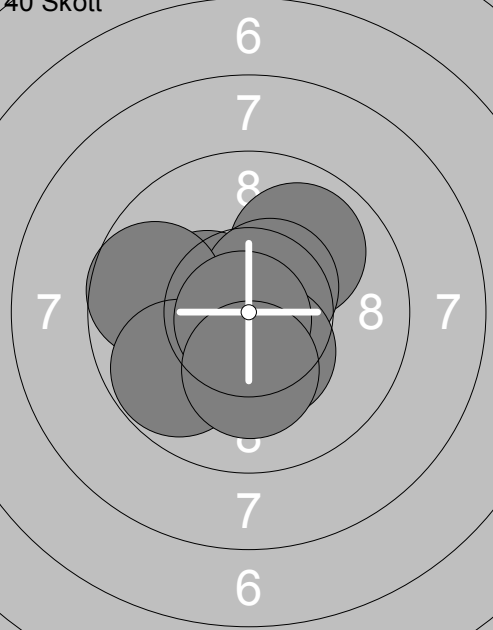
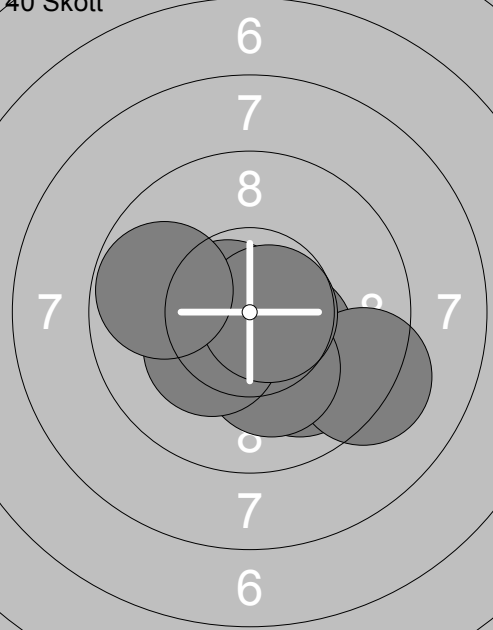
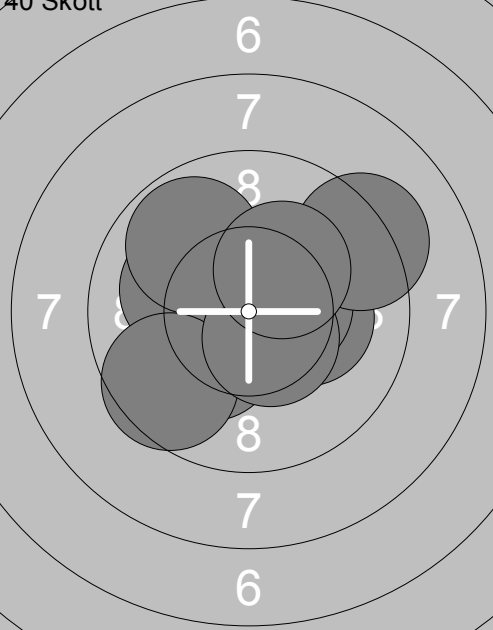
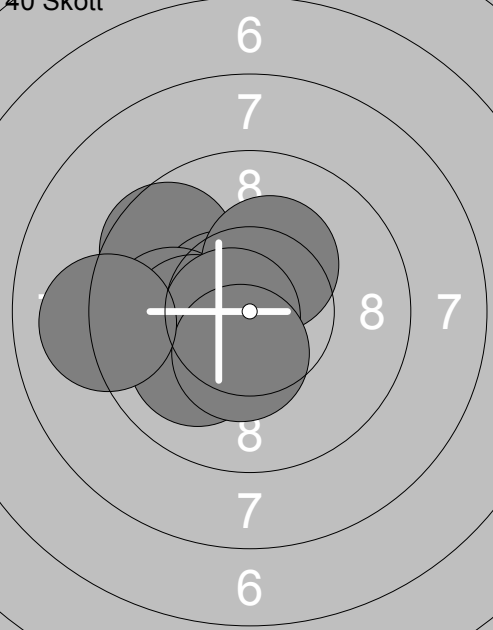
<p>Prov</p> 	<p>1: 10.1 →</p> <p>2: 10.5x →</p> <p>3: 10.6x ↓</p> <p>4: 9.9 →</p> <p>5: 9.0 →</p> <p>6: 10.4x ↓</p> <p>7: 10.3x →</p> <p>8: 10.1 ↗</p> <p>9: 10.8x ↘</p> <p>10: 9.1 ↗</p> <p>Serie 100.8</p> <p>Total 0.0</p>	<p>Prov</p> 	<p>11: 10.8x ↗</p> <p>12: 10.4x ↘</p> <p>Serie 21.2</p> <p>Total 0.0</p>
<p>40 Skott</p> 	<p>1: 10.5x ↘</p> <p>2: 10.2x ↘</p> <p>3: 10.4x ↘</p> <p>4: 9.9 ↗</p> <p>5: 10.5x ↗</p> <p>6: 9.7 ←</p> <p>7: 9.8 ↙</p> <p>8: 10.4x ↓</p> <p>9: 10.8x ↓</p> <p>10: 10.2x ↓</p> <p>Serie 102.4</p> <p>Total 102.4</p>	<p>40 Skott</p> 	<p>11: 10.0 ↘</p> <p>12: 10.4x ↘</p> <p>13: 9.3 ↘</p> <p>14: 10.2x ↓</p> <p>15: 10.4x ↘</p> <p>16: 10.7x ↘</p> <p>17: 10.7x ↘</p> <p>18: 10.3x ↓</p> <p>19: 10.7x →</p> <p>20: 9.8 ←</p> <p>Serie 102.5</p> <p>Total 204.9</p>
<p>40 Skott</p> 	<p>21: 10.2x ↘</p> <p>22: 10.2x ↓</p> <p>23: 10.1 ←</p> <p>24: 10.2x →</p> <p>25: 10.5x →</p> <p>26: 9.2 ↗</p> <p>27: 9.6 ↙</p> <p>28: 10.5x ↓</p> <p>29: 9.8 ↖</p> <p>30: 10.3x ↗</p> <p>Serie 100.6</p> <p>Total 305.5</p>	<p>40 Skott</p> 	<p>31: 10.4x ↓</p> <p>32: 9.6 ↖</p> <p>33: 10.6x ↘</p> <p>34: 10.0 ←</p> <p>35: 10.3x ↗</p> <p>36: 10.2x ↘</p> <p>37: 10.0 ↙</p> <p>38: 10.7x ↘</p> <p>39: 10.4x ↓</p> <p>40: 9.1 ←</p> <p>Serie 101.3</p> <p>Total 406.8</p>

<p><b>Prov</b></p>	<p>1: 9.2 →                  2: 10.2x↘                  3: 10.1 →                  4: 9.4 ↘                  5: 10.8x→                  6: 9.0 →                  7: 10.5x↘                  8: 8.1 ↘                  9: 10.4x↘                  10: 10.8x→</p> <p>Serie 98.5 Total 0.0</p>	<p><b>Prov</b></p>	<p>11: 9.2 →</p> <p>Serie 9.2 Total 0.0</p>
<p><b>40 Skott</b></p>	<p>1: 9.0 ↘                  2: 9.6 →                  3: 10.8x↘                  4: 9.7 →                  5: 9.7 →                  6: 10.5x↘                  7: 9.9 →                  8: 10.2x↘                  9: 10.1 ←                  10: 10.6x↗</p> <p>Serie 100.1 Total 100.1</p>	<p><b>40 Skott</b></p>	<p>11: 10.7x→                  12: 9.7 ↙                  13: 10.8x↑                  14: 10.5x↗                  15: 10.7x↘                  16: 10.3x↘                  17: 9.6 →                  18: 10.2x↘                  19: 10.4x↘                  20: 10.2x↘</p> <p>Serie 103.1 Total 203.2</p>
<p><b>40 Skott</b></p>	<p>21: 10.0 ←                  22: 8.6 ←                  23: 9.6 ←                  24: 10.3x↘                  25: 10.8x↘                  26: 10.3x↗                  27: 10.8x↗                  28: 10.3x↘                  29: 9.3 ←                  30: 10.7x↗</p> <p>Serie 100.7 Total 303.9</p>	<p><b>40 Skott</b></p>	<p>31: 9.9 ←                  32: 10.6x↗                  33: 10.0 ←                  34: 10.5x→                  35: 10.7x↗                  36: 10.2x↗                  37: 10.1 ←                  38: 10.1 →                  39: 9.7 ↙                  40: 10.4x↘</p> <p>Serie 102.2 Total 406.1</p>

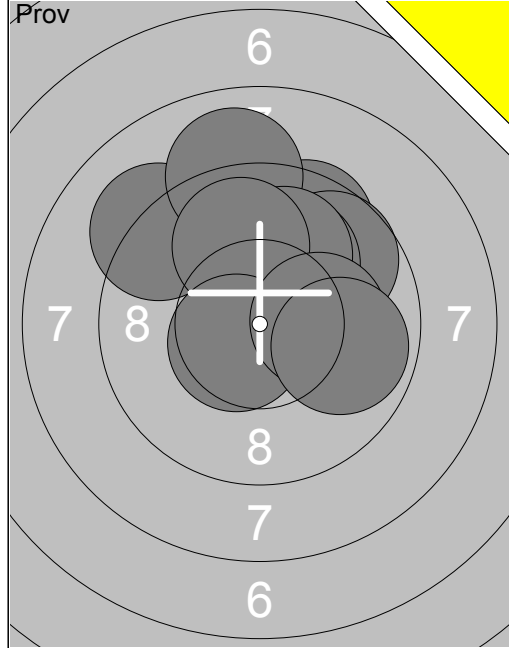

1:	9.6 ↗
2:	9.2 ↖
3:	9.0 ↑
4:	9.7 ↗
5:	10.1 ↗
6:	10.0 ↑
7:	9.9 ↑
8:	10.6x ↙
9:	10.2x ➤
10:	9.9 ➤
Serie	98.2
Total	0.0

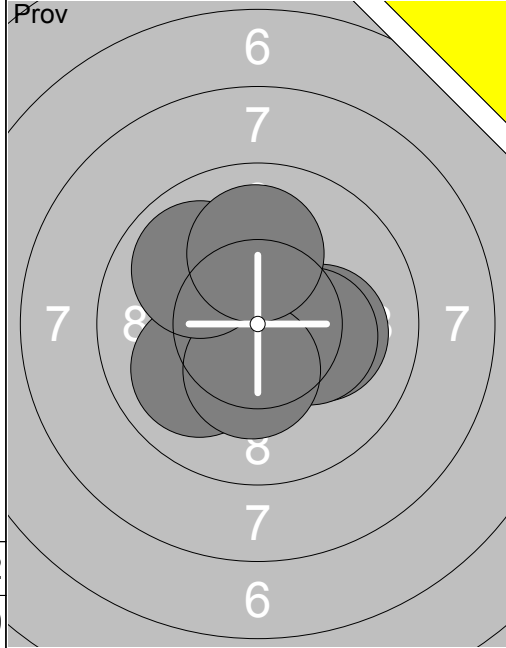

11:	10.1 ➔
12:	10.0 ↙
13:	10.3x ➤
14:	10.3x ↘
15:	9.9 ↖
16:	10.0 ↑
Serie	60.6
Total	0.0

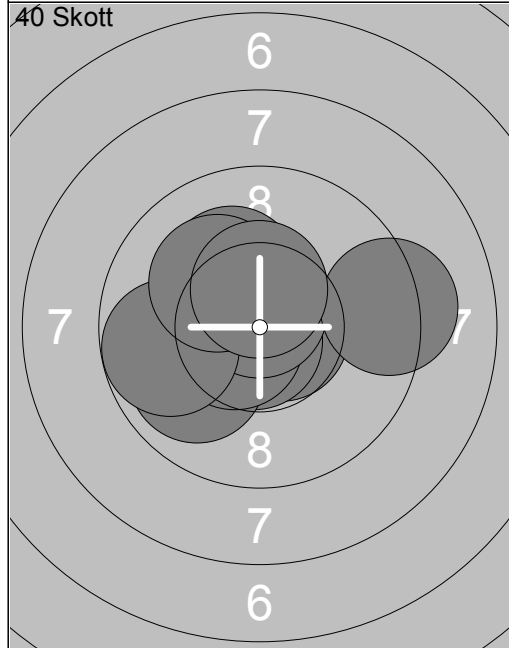

1:	10.7x ➤
2:	10.8x ↘
3:	9.9 ↙
4:	10.2x ↘
5:	10.6x ↙
6:	10.7x ↑
7:	9.2 ➔
8:	9.8 ←
9:	10.2x ↘
10:	10.5x ↑
Serie	102.6
Total	102.6

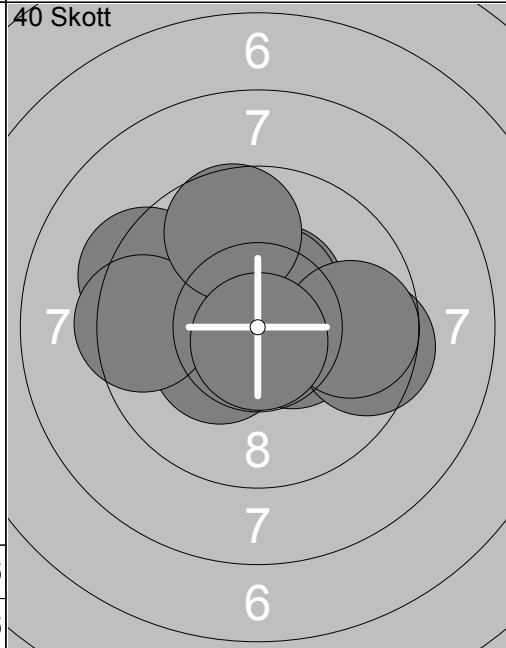

11:	10.4x ↑
12:	10.3x ↙
13:	10.5x ➤
14:	9.4 ↖
15:	9.5 ➔
16:	10.5x ↑
17:	9.4 ←
18:	9.7 ➔
19:	9.7 ↑
20:	10.8x ↘
Serie	100.2
Total	202.8

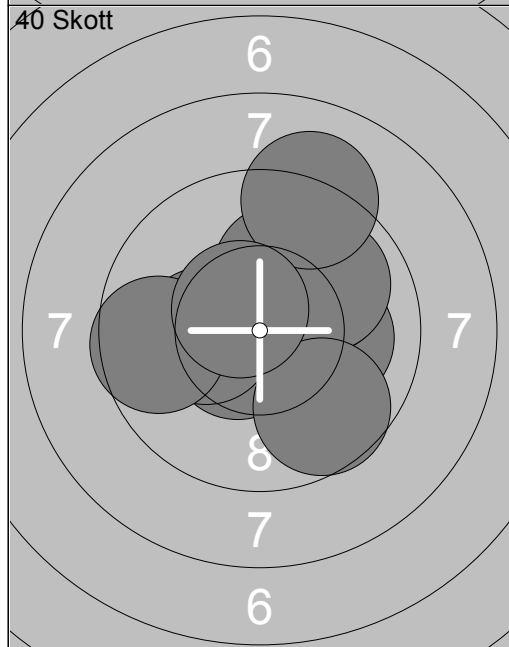

21:	10.6x ↙
22:	10.2x ←
23:	9.6 ←
24:	10.1 ↑
25:	10.1 ➔
26:	10.0 ↗
27:	9.9 ↗
28:	9.1 ↑
29:	9.7 ↘
30:	10.6x ↘
Serie	99.9
Total	302.7

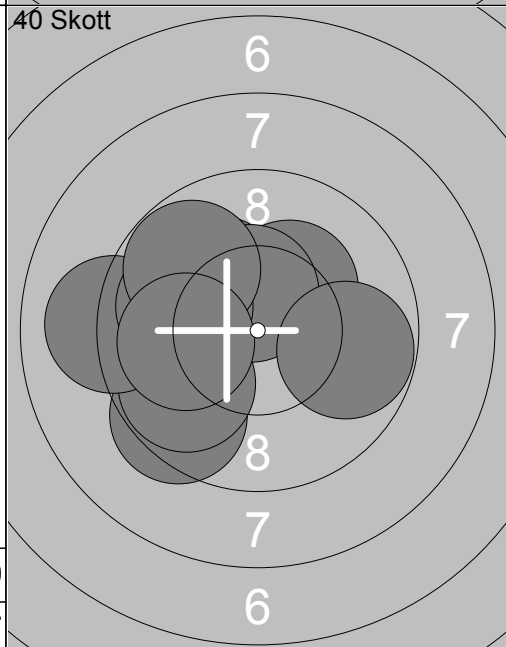

31:	9.4 ↙
32:	10.3x ↑
33:	10.1 ↖
34:	9.8 ↙
35:	10.5x ↑
36:	9.1 ←
37:	9.9 ←
38:	9.8 ➔
39:	9.8 ↖
40:	10.0 ←
Serie	98.7
Total	401.4

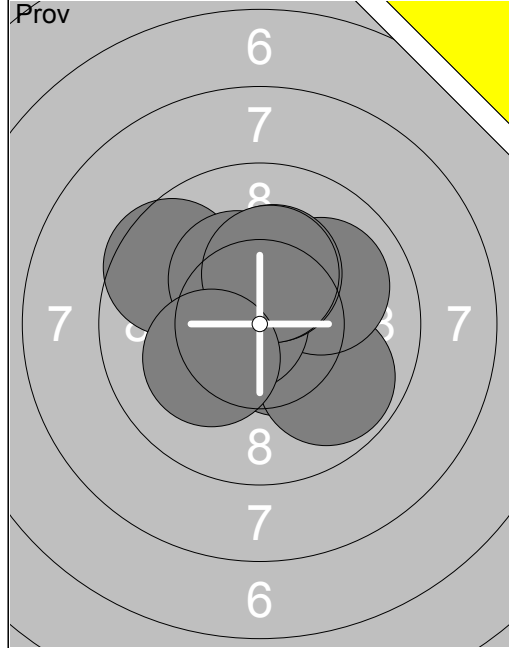

1:	10.5x
2:	9.8
3:	10.3x
4:	10.0
5:	10.7x
6:	9.6
7:	10.3x
8:	10.3x
9:	10.3x
10:	10.2x
Serie	102.0
Total	0.0

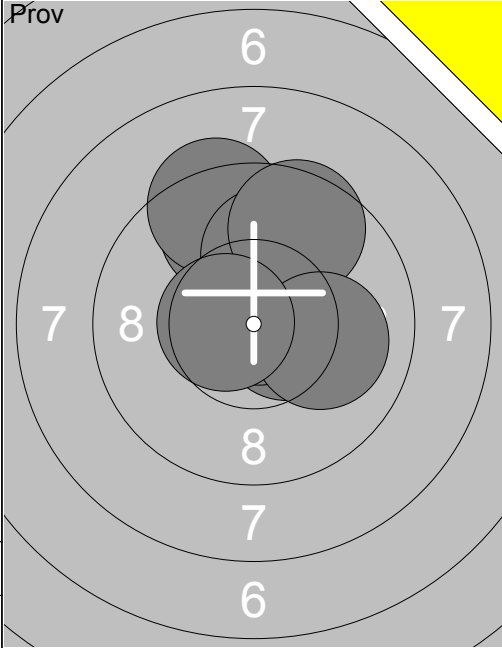

11:	9.7
12:	10.5x
13:	9.3
14:	10.8x
15:	10.0
16:	9.6
17:	10.1
18:	10.6x
Serie	80.6
Total	0.0

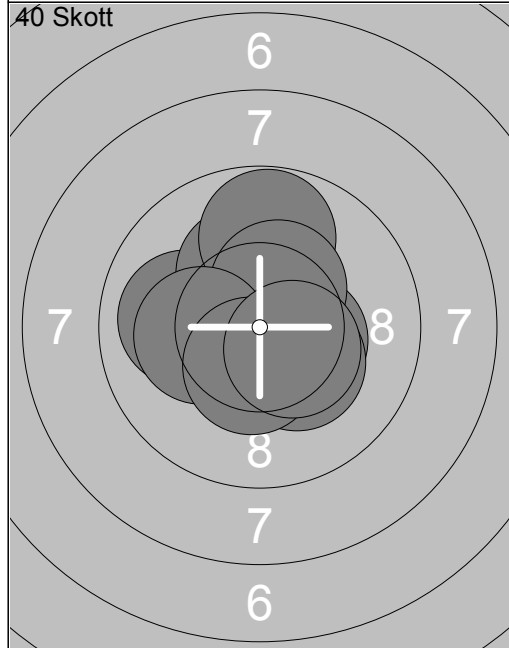

1:	10.4x
2:	10.0
3:	10.2x
4:	10.9x
5:	9.8
6:	10.4x
7:	10.3x
8:	10.2x
9:	10.4x
10:	10.4x
Serie	103.0
Total	103.0

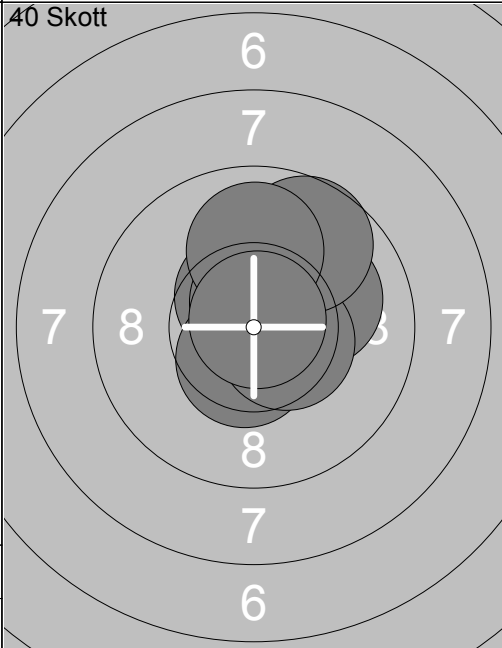

11:	10.7x
12:	10.5x
13:	10.5x
14:	10.0
15:	10.1
16:	10.6x
17:	10.5x
18:	9.7
19:	10.0
20:	10.8x
Serie	103.4
Total	206.4

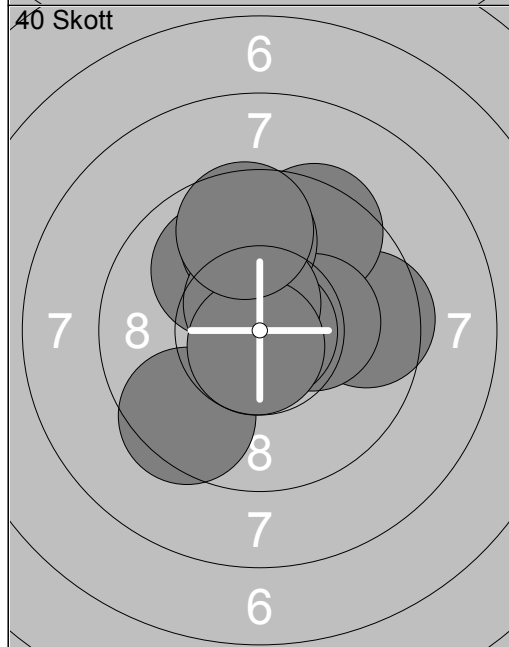

21:	9.5
22:	9.6
23:	9.5
24:	10.3x
25:	10.0
26:	10.8x
27:	9.8
28:	10.6x
29:	10.7x
30:	9.6
Serie	100.4
Total	306.8

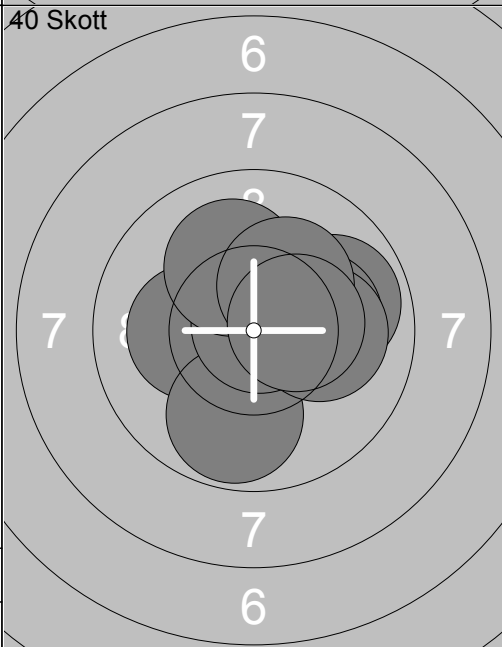

31:	10.7x
32:	10.2x
33:	9.8
34:	9.9
35:	10.2x
36:	10.8x
37:	10.1
38:	10.1
39:	10.2x
40:	10.4x
Serie	102.4
Total	409.2

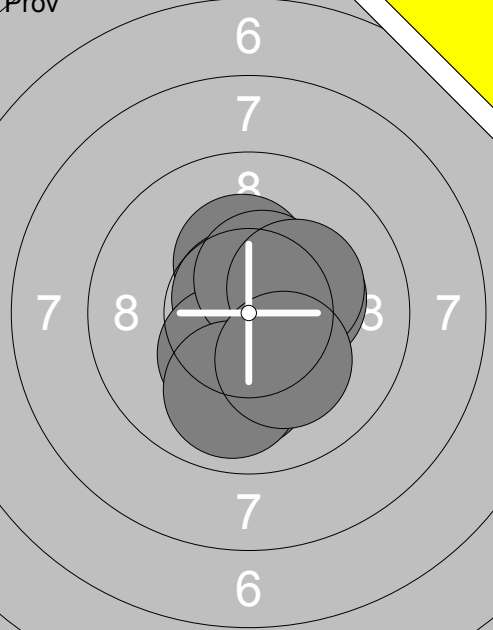
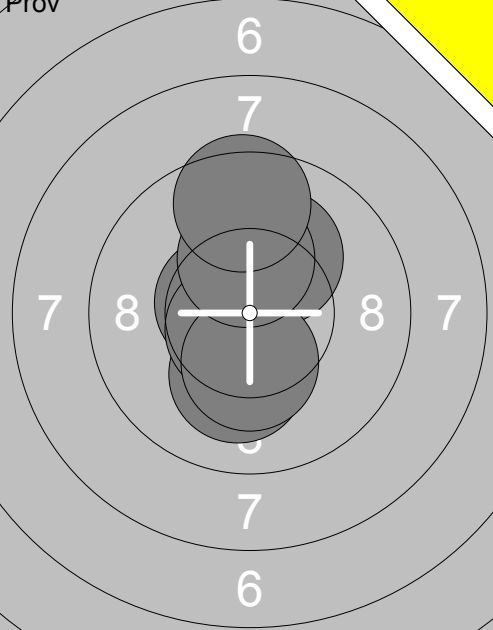
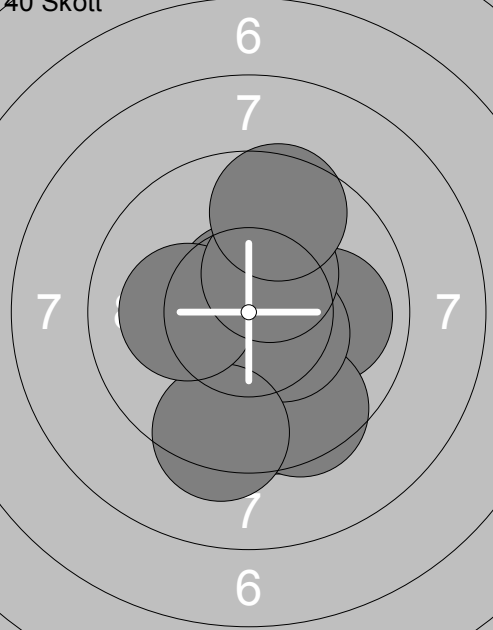
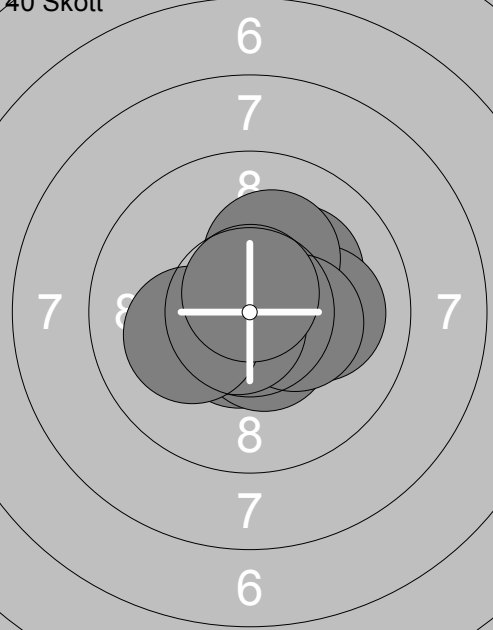
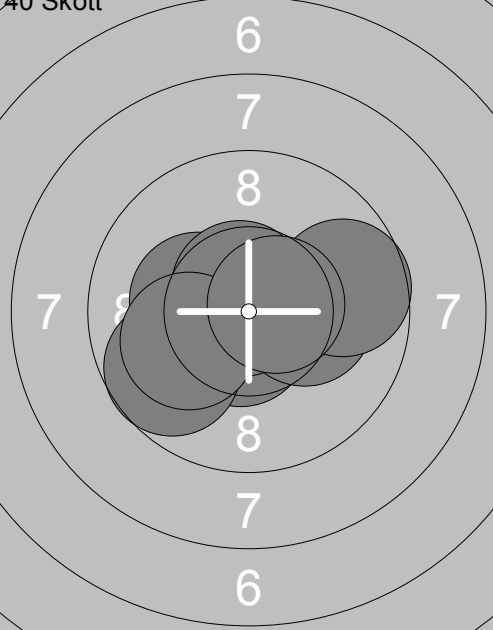
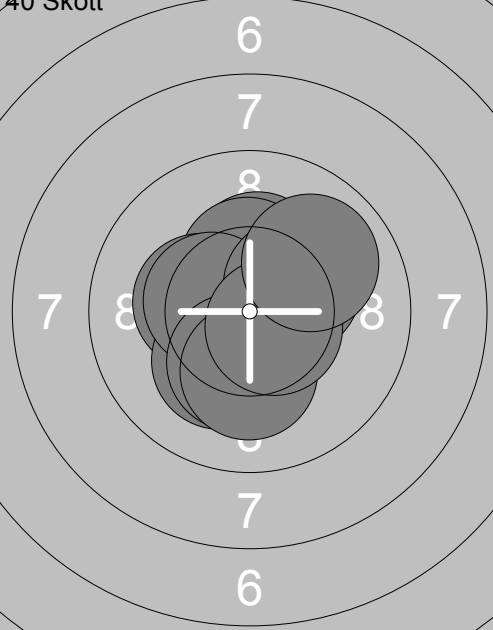
<p>Prov</p> 	<p>1: 10.3x ↗                  2: 10.1 ↓                  3: 10.5x →                  4: 10.7x ↗                  5: 10.3x ↘                  6: 10.5x ↗                  7: 9.9 ↓                  8: 10.3x →                  9: 10.3x ↗                  10: 10.2x ↘</p> <p>Serie 103.1 Total 0.0</p>	<p>Prov</p> 	<p>11: 10.6x ↘                  12: 10.1 ↓                  13: 10.7x ↘                  14: 10.1 ↗                  15: 10.3x ↘                  16: 10.2x ↗                  17: 9.5 ↑</p> <p>Serie 71.5 Total 0.0</p>
<p>40 Skott</p> 	<p>1: 9.7 ↓                  2: 10.7x ↗                  3: 10.4x ↘                  4: 10.0 →                  5: 9.5 ↓                  6: 10.4x ↘                  7: 9.3 ↓                  8: 10.1 ←                  9: 10.4x ↗                  10: 9.6 ↗</p> <p>Serie 100.1 Total 100.1</p>	<p>40 Skott</p> 	<p>11: 10.5x ↘                  12: 10.6x ↘                  13: 10.2x ↗                  14: 10.1 →                  15: 10.5x ↘                  16: 10.2x ↗                  17: 10.3x →                  18: 10.7x ↘                  19: 10.1 ←                  20: 10.7x ↗</p> <p>Serie 103.9 Total 204.0</p>
<p>40 Skott</p> 	<p>21: 10.6x ↘                  22: 10.3x ↘                  23: 10.6x ↘                  24: 9.7 ↙                  25: 10.2x →                  26: 10.8x ↘                  27: 9.7 →                  28: 10.6x ↗                  29: 10.1 ←                  30: 10.6x →</p> <p>Serie 103.2 Total 307.2</p>	<p>40 Skott</p> 	<p>31: 10.3x ↗                  32: 10.4x ↗                  33: 10.3x ↘                  34: 10.2x ↘                  35: 10.4x ↘                  36: 10.3x ↘                  37: 10.3x ↗                  38: 10.2x ↘                  39: 10.6x ↘                  40: 9.9 ↗</p> <p>Serie 102.9 Total 410.1</p>

<p>Prov</p>	<p>1: 10.7x ↘                  2: 10.2x ↗                  3: 10.5x ↘                  4: 10.1 →                  5: 10.3x ↓                  6: 9.9 ←                  7: 10.3x ↓                  8: 10.1 →                  9: 10.8x ↘                  10: 10.5x ↗</p> <p>Serie 103.4 Total 0.0</p>	<p>Prov</p>	<p>11: 10.5x ↘                  12: 9.9 ↗</p> <p>Serie 20.4 Total 0.0</p>
<p>40 Skott</p>	<p>1: 10.2x ↘                  2: 9.8 ↗                  3: 10.0 ←                  4: 10.5x ↗                  5: 10.7x ↘                  6: 10.6x ↗                  7: 10.5x ↓                  8: 9.9 →                  9: 10.0 ↓                  10: 9.9 ↓</p> <p>Serie 102.1 Total 102.1</p>	<p>40 Skott</p>	<p>11: 10.3x ↗                  12: 10.5x ↗                  13: 9.9 ←                  14: 10.5x ↘                  15: 9.8 →                  16: 10.5x →                  17: 10.1 ↗                  18: 10.8x ↘                  19: 10.2x ↗                  20: 9.3 ←</p> <p>Serie 101.9 Total 204.0</p>
<p>40 Skott</p>	<p>21: 10.2x ↘                  22: 10.2x ↓                  23: 10.9x ↗                  24: 10.5x ↓                  25: 10.0 ←                  26: 10.4x ↗                  27: 10.6x ↗                  28: 10.3x ↘                  29: 10.3x →                  30: 9.9 ↗</p> <p>Serie 103.3 Total 307.3</p>	<p>40 Skott</p>	<p>31: 10.4x ↓                  32: 10.8x ↘                  33: 10.4x →                  34: 10.2x ↗                  35: 10.3x ↓                  36: 10.4x ↓                  37: 9.5 ←                  38: 10.2x ↓                  39: 10.3x ↘                  40: 10.4x →</p> <p>Serie 102.9 Total 410.2</p>

	1: 10.1 ↘		11: 10.1 ←
	2: 10.3x ➤		12: 10.5x ↗
	3: 10.4x ↘		13: 10.4x ↘
	4: 10.5x ↗		14: 10.3x ➤
	5: 10.4x ↘		15: 10.0 ↖
	6: 10.8x ↖		16: 10.5x ↗
	7: 10.3x ➤		17: 9.3 ↖
	8: 10.8x ↘		
	9: 10.4x ↗		
	10: 9.9 ↙		
Serie 103.9		Serie 71.1	
Total 0.0		Total 0.0	

	1: 10.5x ➤		11: 10.5x ↑
	2: 10.2x ↖		12: 10.7x ↖
	3: 10.8x ↘		13: 10.2x ↘
	4: 10.5x ➤		14: 10.9x ↖
	5: 10.5x ↑		15: 10.1 ↘
	6: 10.3x ↑		16: 10.5x ↘
	7: 10.6x ↘		17: 10.3x ↘
	8: 9.5 ↖		18: 10.7x ↘
	9: 10.4x ➤		19: 10.2x ↗
	10: 10.3x ↑		20: 10.2x ➤
Serie 103.6		Serie 104.3	
Total 103.6		Total 207.9	

	21: 10.5x ↗		31: 10.1 ↘
	22: 10.1 ←		32: 10.7x ↘
	23: 9.8 ➤		33: 10.5x ↖
	24: 9.9 ➤		34: 10.7x ↖
	25: 10.8x ↘		35: 10.6x ↑
	26: 10.6x ↖		36: 10.7x ↘
	27: 10.7x ↑		37: 10.0 ↖
	28: 10.7x ➤		38: 10.5x ↘
	29: 10.7x ↑		39: 10.1 ↖
	30: 9.7 ➤		40: 10.2x ↖
Serie 103.5		Serie 104.1	
Total 311.4		Total 415.5	

<p>Prov</p>	<p>1: 9.4 ←</p> <p>2: 10.2x ↘</p> <p>3: 9.9 ↖</p> <p>4: 10.0 ↖</p> <p>5: 10.7x ←</p> <p>6: 10.5x ↘</p> <p>7: 10.4x →</p> <p>8: 10.4x →</p> <p>9: 10.0 ↗</p> <p>10: 10.9x ↘</p> <p>Serie 102.4</p> <p>Total 0.0</p>	<p>Prov</p>	<p>11: 10.0 ↘</p> <p>12: 10.5x ↗</p> <p>13: 10.7x ↘</p> <p>14: 9.9 →</p> <p>Serie 41.1</p> <p>Total 0.0</p>
<p>40 Skott</p>	<p>1: 10.5x ↗</p> <p>2: 9.6 ↗</p> <p>3: 10.5x ↘</p> <p>4: 10.7x ↘</p> <p>5: 10.4x ↗</p> <p>6: 10.4x ↗</p> <p>7: 10.2x →</p> <p>8: 10.2x ↗</p> <p>9: 10.9x ↘</p> <p>10: 9.0 →</p> <p>Serie 102.4</p> <p>Total 102.4</p>	<p>40 Skott</p>	<p>11: 9.8 →</p> <p>12: 10.8x ←</p> <p>13: 10.1 →</p> <p>14: 10.2x ↗</p> <p>15: 10.4x ↘</p> <p>16: 10.6x ↘</p> <p>17: 10.4x ↘</p> <p>18: 10.4x →</p> <p>19: 10.4x ←</p> <p>20: 10.5x →</p> <p>Serie 103.6</p> <p>Total 206.0</p>
<p>40 Skott</p>	<p>21: 10.1 ↗</p> <p>22: 10.6x ↗</p> <p>23: 10.3x →</p> <p>24: 10.9x ↗</p> <p>25: 10.2x ↘</p> <p>26: 10.2x ↘</p> <p>27: 10.2x ↘</p> <p>28: 10.9x →</p> <p>29: 10.1 ←</p> <p>30: 10.3x ↘</p> <p>Serie 103.8</p> <p>Total 309.8</p>	<p>40 Skott</p>	<p>31: 10.6x →</p> <p>32: 9.4 ←</p> <p>33: 10.7x ↘</p> <p>34: 10.6x →</p> <p>35: 10.7x ↘</p> <p>36: 10.3x ↘</p> <p>37: 10.6x ↗</p> <p>38: 9.8 ←</p> <p>39: 10.6x ↘</p> <p>40: 10.4x →</p> <p>Serie 103.7</p> <p>Total 413.5</p>



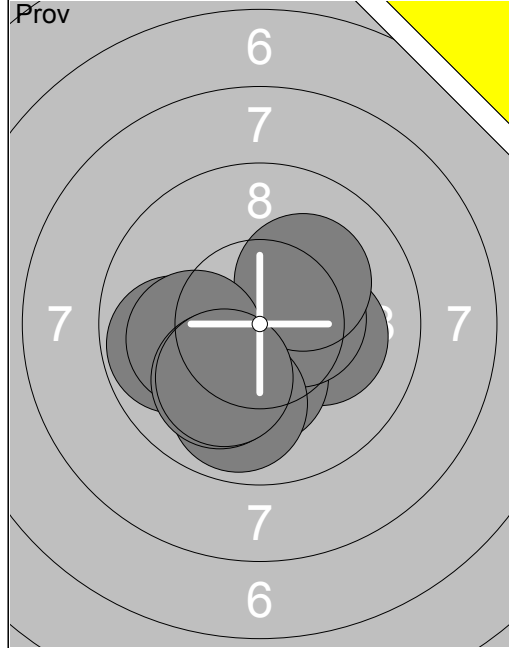

1:	10.3x↗
2:	10.2x→
3:	10.3x↓
4:	10.5x→
5:	10.2x↗
6:	9.8 ←
7:	10.1←
8:	9.9 ↓
9:	10.1↓
10:	10.1↓
Serie	101.5
Total	0.0

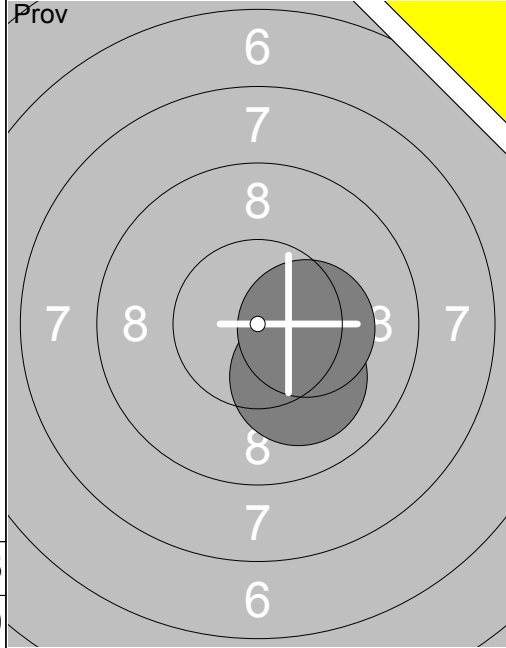

11:	10.1 ↓
12:	10.3x→
Serie	20.4
Total	0.0

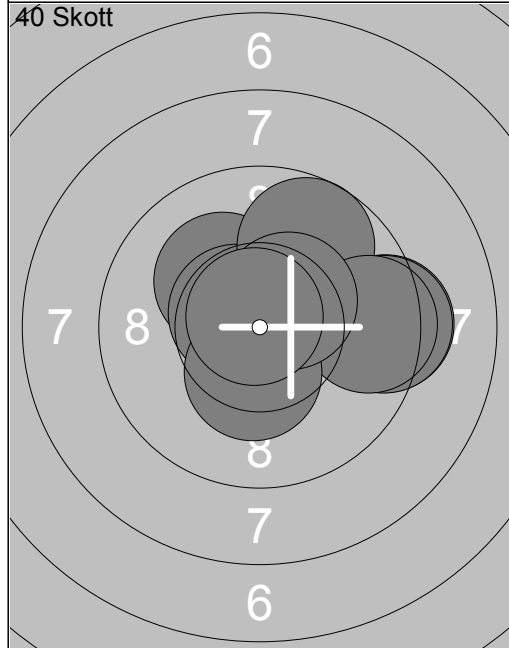

1:	9.3 →
2:	10.2x↗
3:	10.6x↗
4:	9.3 →
5:	9.7 ↗
6:	10.9x↓
7:	9.5 →
8:	10.4x↓
9:	10.4x↗
10:	10.8x↗
Serie	101.1
Total	101.1

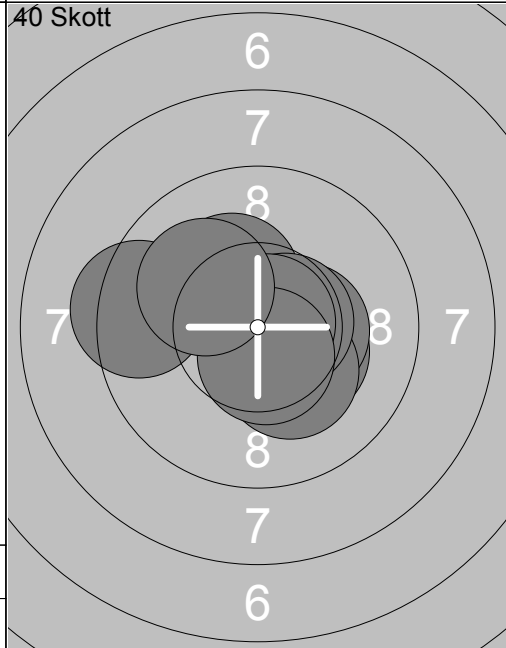

11:	10.3x↗
12:	10.4x→
13:	10.3x↗
14:	10.6x↗
15:	10.2x↓
16:	9.4 ←
17:	10.6x→
18:	10.8x↗
19:	10.6x↓
20:	10.1 ↖
Serie	103.3
Total	204.4

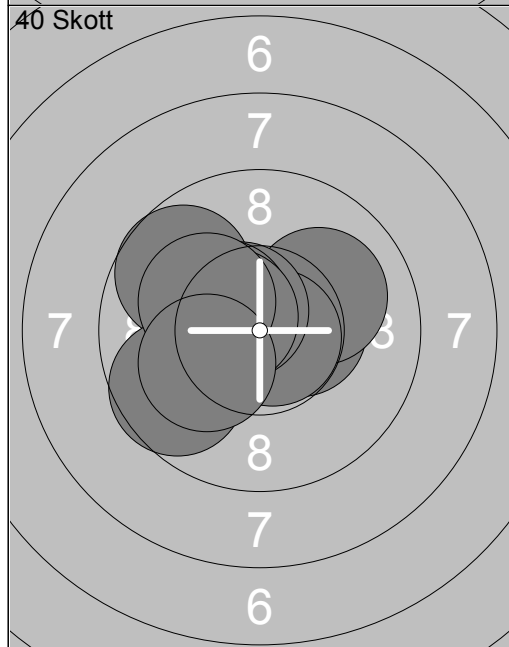

21:	9.7 ↖
22:	10.4x→
23:	10.1 ↗
24:	10.8x↗
25:	9.6 ←
26:	10.6x↗
27:	10.4x↗
28:	10.5x↗
29:	10.2x↗
30:	10.1←
Serie	102.4
Total	306.8

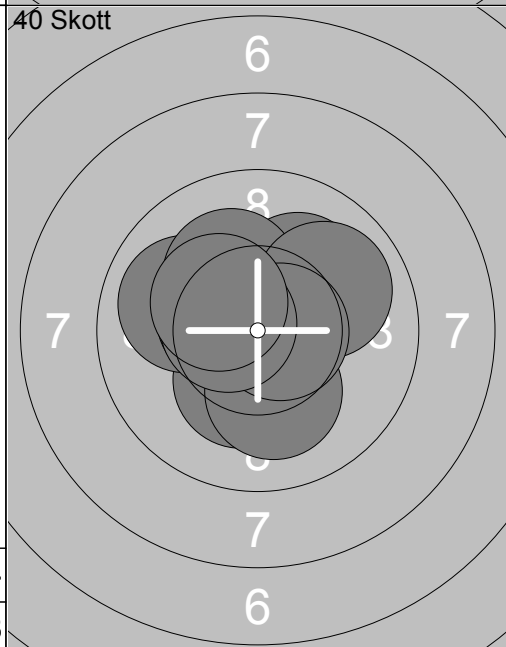

31:	10.3x↓
32:	10.0←
33:	10.5x↗
34:	10.1 ↗
35:	10.2x↗
36:	9.9 ↗
37:	10.1 ↓
38:	10.7x→
39:	10.6x↗
40:	10.3x↗
Serie	102.7
Total	409.5

<p>Prov</p>	<p>1: 10.1 ↓</p> <p>2: 10.2 ✕</p> <p>3: 10.1 ←</p> <p>4: 10.3 ✕</p> <p>5: 10.3 ✕</p> <p>6: 10.4 ✕</p> <p>7: 9.1 →</p> <p>8: 10.4 ✕</p> <p>9: 10.5 ✕</p> <p>10: 10.4 ✕</p> <p>Serie 101.8</p> <p>Total 0.0</p>	<p>Prov</p>	<p>11: 10.7 ✕ ↓</p> <p>12: 9.9 ↓</p> <p>13: 10.4 ✕</p> <p>14: 10.2 ✕</p> <p>15: 10.1 →</p> <p>16: 10.5 ✕ →</p> <p>Serie 61.8</p> <p>Total 0.0</p>
-------------	---	-------------	---

<p>40 Skott</p>	<p>1: 10.3 ✕ →</p> <p>2: 9.7 ↓</p> <p>3: 10.3 ✕ ↗</p> <p>4: 10.2 ✕ ←</p> <p>5: 10.4 ✕ ↗</p> <p>6: 10.5 ✕ ←</p> <p>7: 10.2 ✕ ←</p> <p>8: 10.2 ✕ ↗</p> <p>9: 10.7 ✕ ↗</p> <p>10: 10.2 ✕ ←</p> <p>Serie 102.7</p> <p>Total 102.7</p>	<p>40 Skott</p>	<p>11: 9.5 ↑</p> <p>12: 10.1 ↖</p> <p>13: 9.8 →</p> <p>14: 9.6 ↑</p> <p>15: 10.1 ↓</p> <p>16: 10.4 ✕ ↓</p> <p>17: 9.6 ↓</p> <p>18: 10.0 ↘</p> <p>19: 10.1 ↑</p> <p>20: 10.0 →</p> <p>Serie 99.2</p> <p>Total 201.9</p>
-----------------	---	-----------------	--

<p>40 Skott</p>	<p>21: 9.3 ←</p> <p>22: 10.0 ←</p> <p>23: 10.4 ✕ ↓</p> <p>24: 10.2 ✕ ↓</p> <p>25: 10.2 ✕ ←</p> <p>26: 10.7 ✕ →</p> <p>27: 10.3 ✕ ←</p> <p>28: 10.0 ←</p> <p>29: 10.0 ↑</p> <p>30: 10.2 ✕ ↗</p> <p>Serie 101.3</p> <p>Total 303.2</p>	<p>40 Skott</p>	<p>31: 9.6 →</p> <p>32: 10.5 ✕ ↗</p> <p>33: 9.3 →</p> <p>34: 10.5 ✕ ←</p> <p>35: 9.5 ↖</p> <p>36: 9.4 ↑</p> <p>37: 9.9 ←</p> <p>38: 9.7 ↗</p> <p>39: 10.5 ✕ ←</p> <p>40: 9.9 ↗</p> <p>Serie 98.8</p> <p>Total 402.0</p>
-----------------	--	-----------------	---

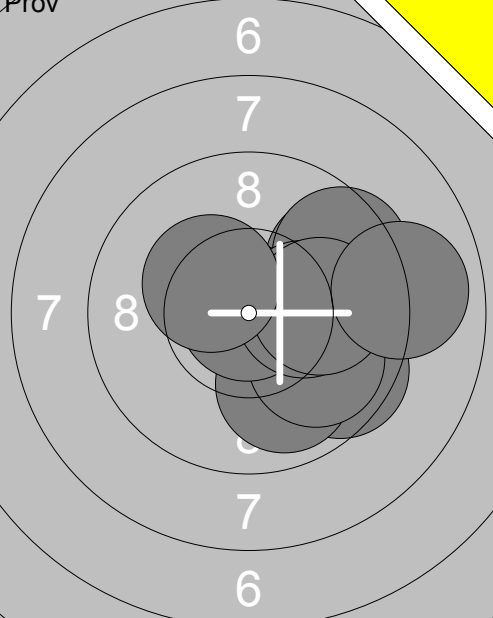
<p>Prov</p> 	<p>1: 9.5 ↘                  2: 9.9 ↓                  3: 9.9 ↘                  4: 9.7 ↗                  5: 9.5 ↗                  6: 10.9 ✕                  7: 10.2 ✕ →                  8: 10.0 →                  9: 10.3 ✕                  10: 9.0 →</p> <p>Serie 98.9 Total 0.0</p>	<p>Prov</p> 	<p>11: 10.1 ↖                  12: 9.9 ↙</p> <p>Serie 20.0 Total 0.0</p>
--	--	--	--

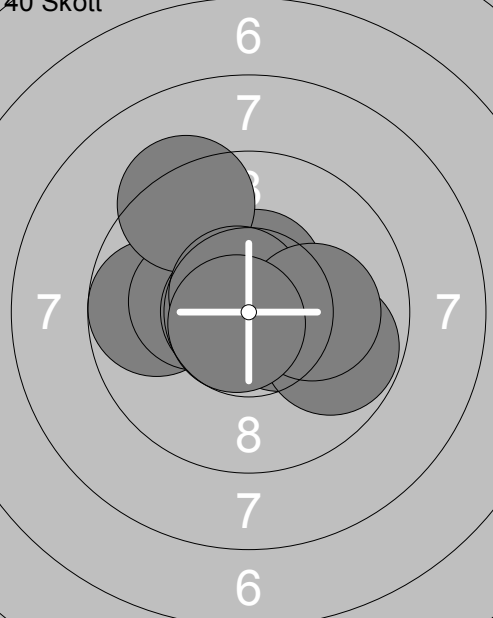
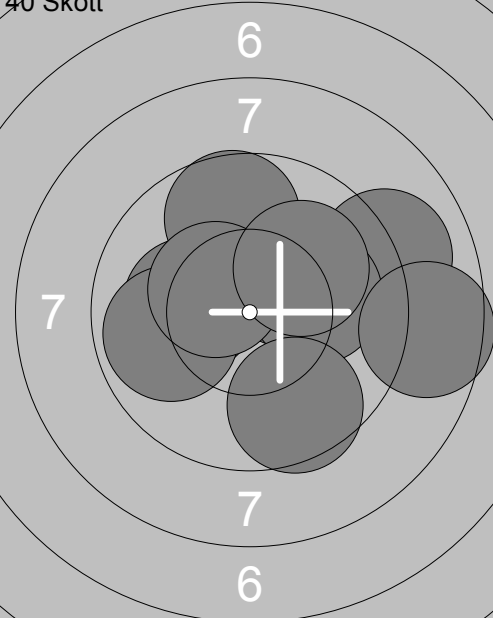
<p>40 Skott</p> 	<p>1: 10.5 ✕ ↑                  2: 10.5 ✕ →                  3: 9.7 ←                  4: 10.3 ✕                  5: 10.7 ✕                  6: 9.3 ↑                  7: 10.7 ✕                  8: 9.8 →                  9: 10.1 →                  10: 10.7 ✕</p> <p>Serie 102.3 Total 102.3</p>	<p>40 Skott</p> 	<p>11: 9.0 →                  12: 10.2 ✕                  13: 9.9 ←                  14: 10.3 ✕ ↗                  15: 9.7 ↑                  16: 10.1 →                  17: 10.4 ✕                  18: 10.1 ↗                  19: 8.6 →                  20: 9.6 ↓</p> <p>Serie 97.9 Total 200.2</p>
---	--	---	--

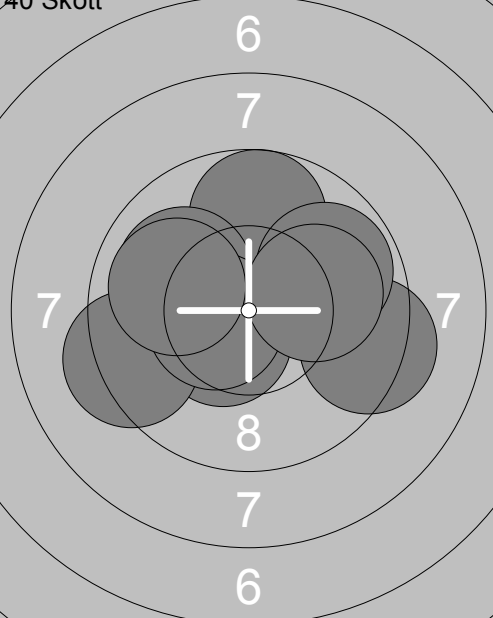
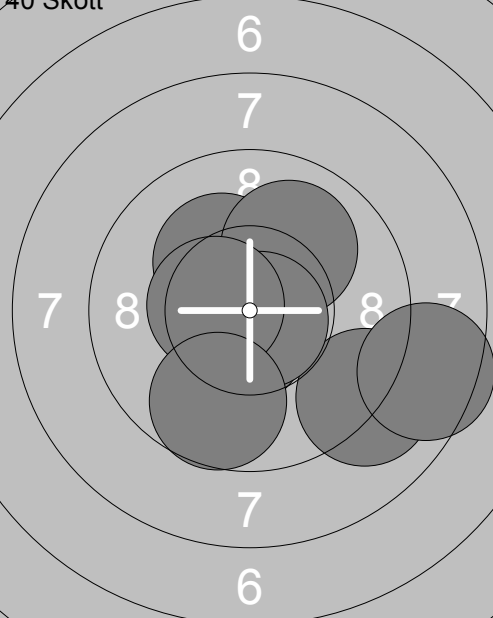
<p>40 Skott</p> 	<p>21: 10.5 ✕                  22: 9.3 →                  23: 10.5 ✕                  24: 9.3 ←                  25: 9.7 ↑                  26: 10.0 ↖                  27: 9.8 ↗                  28: 10.5 ✕                  29: 10.1 →                  30: 10.0 ↖</p> <p>Serie 99.7 Total 299.9</p>	<p>40 Skott</p> 	<p>31: 9.1 ↘                  32: 8.5 →                  33: 10.2 ✕                  34: 10.8 ✕ ↑                  35: 10.6 ✕ ↓                  36: 10.7 ✕                  37: 10.0 ↗                  38: 10.8 ✕                  39: 10.5 ✕                  40: 9.7 ↓</p> <p>Serie 100.9 Total 400.8</p>
--	---	--	---

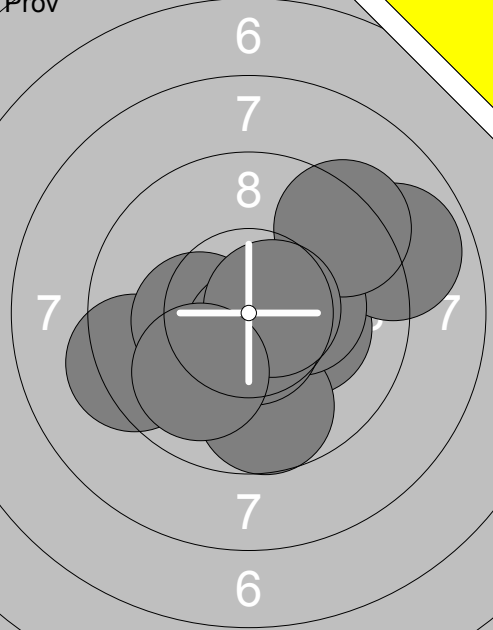
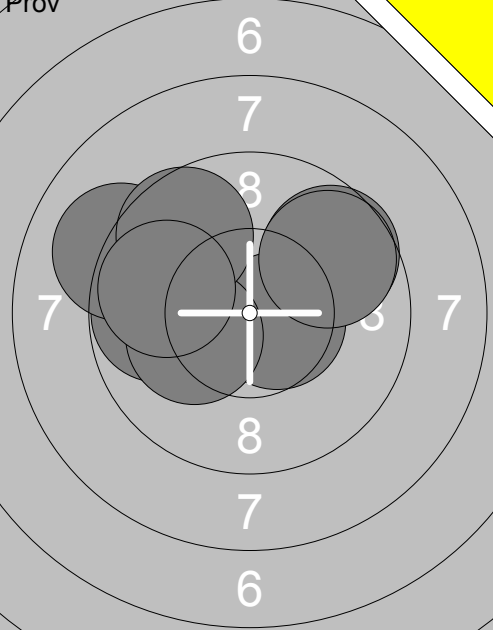
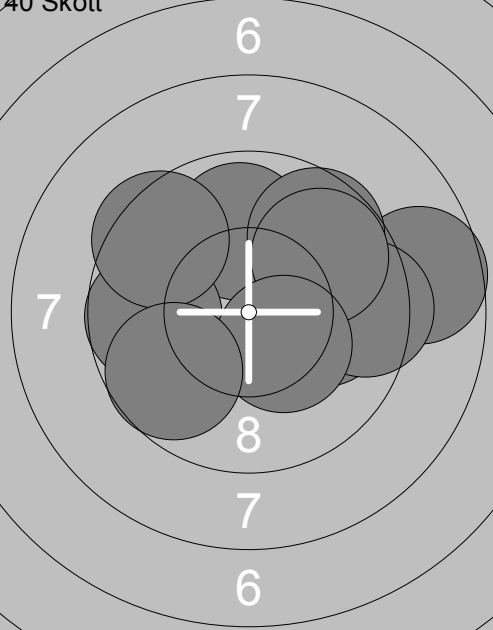
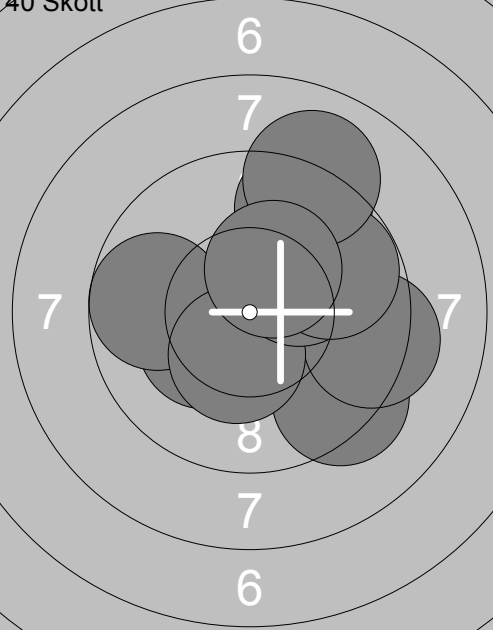
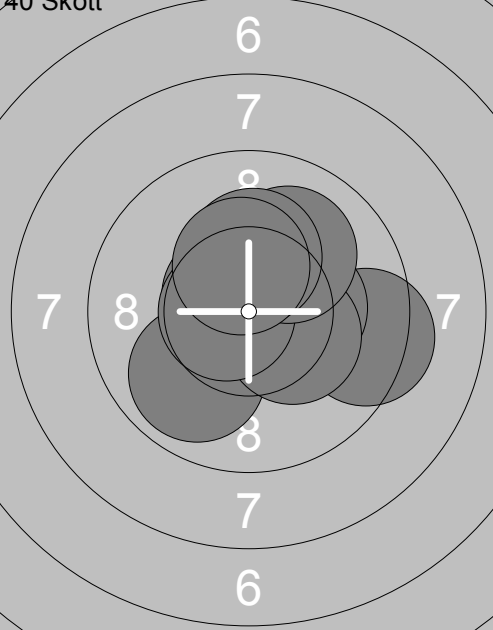
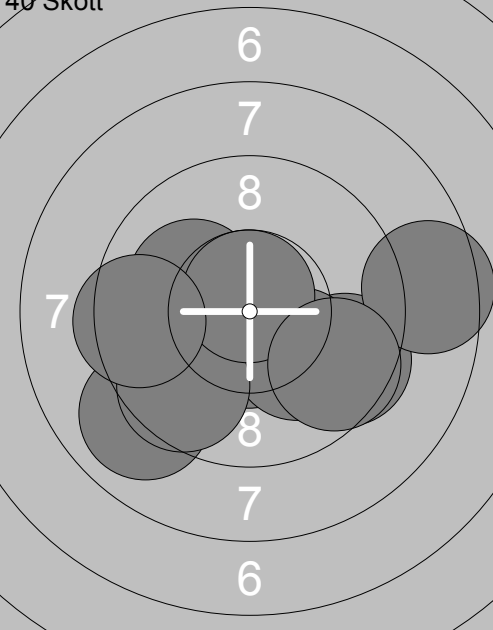
Prov	Prov	
		
1: 10.2x➤ 2: 9.3 ← 3: 8.9 ➔ 4: 10.3x← 5: 9.7 ↓ 6: 10.3x➤ 7: 10.6x↓ 8: 9.3 ↗ 9: 10.6x➤ 10: 10.0 ↓ Serie 99.2 Total 0.0	11: 9.8 ← 12: 9.6 ↗ 13: 10.6x➤ 14: 9.7 ↗ 15: 9.1 ← 16: 10.2x← 17: 9.6 ↖ 18: 9.8 ← Serie 78.4 Total 0.0	
		
40 Skott 1: 9.9 ↑ 2: 9.7 ← 3: 10.0 ➔ 4: 8.7 ➔ 5: 9.4 ➔ 6: 9.6 ↗ 7: 9.8 ↗ 8: 10.3x↓ 9: 9.5 ↖ 10: 9.7 ↙ Serie 96.6 Total 96.6	11: 10.3x← 12: 9.3 ↘ 13: 9.7 ← 14: 9.4 ↗ 15: 9.3 ➔ 16: 10.4x↓ 17: 10.2x↗ 18: 9.8 ➔ 19: 9.0 ↗ 20: 10.3x↗ Serie 97.7 Total 194.3	
		
40 Skott 21: 10.5x➤ 22: 9.4 ➔ 23: 10.3x➤ 24: 9.9 ↓ 25: 10.6x↖ 26: 10.3x↘ 27: 10.7x← 28: 10.0 ↗ 29: 10.2x↑ 30: 10.4x↑ Serie 102.3 Total 296.6	31: 9.0 ↙ 32: 9.5 ➤ 33: 10.5x↓ 34: 10.1 ↘ 35: 8.5 ➔ 36: 10.1 ↖ 37: 9.6 ↙ 38: 10.7x↑ 39: 9.5 ← 40: 9.6 ➤ Serie 97.1 Total 393.7	

	1: 9.5 ↙ 2: 9.7 ↙ 3: 9.8 ↗ 4: 9.9 → 5: 10.3x↗ 6: 10.6x↗ 7: 10.5x↘ 8: 9.5 → 9: 10.4x→ 10: 10.4x↘		11: 10.7x↖ 12: 9.7 → 13: 8.7 ↓ 14: 10.0 ↓ 15: 10.5x↗ 16: 8.7 ↘
	Serie 100.6 Total 0.0		Serie 58.3 Total 0.0

	1: 10.3x↘ 2: 10.4x↘ 3: 10.3x↘ 4: 10.5x↘ 5: 10.5x↖ 6: 10.6x↖ 7: 9.9 ↙ 8: 10.1 → 9: 9.0 → 10: 10.6x↗		11: 10.3x↖ 12: 10.0 ↙ 13: 10.4x↘ 14: 10.4x→ 15: 10.6x↖ 16: 9.8 ↖ 17: 10.5x→ 18: 9.7 ↖ 19: 9.7 ↙ 20: 10.3x↗
	Serie 102.2 Total 102.2		Serie 101.7 Total 203.9

	21: 10.0 → 22: 9.7 ↘ 23: 8.5 → 24: 10.1 ↙ 25: 10.3x↗ 26: 10.8x↘ 27: 9.5 → 28: 10.3x↗ 29: 9.6 → 30: 10.7x↗		31: 10.5x↗ 32: 10.3x↖ 33: 10.6x↗ 34: 10.3x↗ 35: 10.4x↘ 36: 8.0 → 37: 10.2x↖ 38: 10.4x↘ 39: 10.5x↗ 40: 9.7 ↖
	Serie 99.5 Total 303.4		Serie 100.9 Total 404.3

<p>Prov</p>	<p>1: 9.8 ←</p> <p>2: 10.0 ←</p> <p>3: 9.2 ↑</p> <p>4: 10.7x ↗</p> <p>5: 10.6x →</p> <p>6: 9.8 ↖</p> <p>7: 10.5x ↘</p> <p>8: 10.7x ↘</p> <p>9: 10.5x →</p> <p>10: 10.5x ↘</p> <p>Serie 102.3</p> <p>Total 0.0</p>	<p>Prov</p>	<p>11: 10.5x ↗</p> <p>12: 9.7 →</p> <p>Serie 20.2</p> <p>Total 0.0</p>
<p>40 Skott</p>	<p>1: 9.6 ↓</p> <p>2: 10.3x →</p> <p>3: 9.8 →</p> <p>4: 8.9 ↓</p> <p>5: 10.5x ↘</p> <p>6: 10.4x ↓</p> <p>7: 10.2x →</p> <p>8: 10.6x ←</p> <p>9: 10.7x ↓</p> <p>10: 10.4x ↗</p> <p>Serie 101.4</p> <p>Total 101.4</p>	<p>40 Skott</p>	<p>11: 10.0 ↓</p> <p>12: 10.9x →</p> <p>13: 10.5x →</p> <p>14: 10.7x ↗</p> <p>15: 9.8 →</p> <p>16: 9.9 ←</p> <p>17: 9.8 →</p> <p>18: 10.3x ↗</p> <p>19: 10.2x ↘</p> <p>20: 10.1 ↑</p> <p>Serie 102.2</p> <p>Total 203.6</p>
<p>40 Skott</p>	<p>21: 10.1 ←</p> <p>22: 10.9x ↗</p> <p>23: 9.9 ↖</p> <p>24: 8.9 →</p> <p>25: 9.6 ↖</p> <p>26: 9.3 ←</p> <p>27: 9.4 ↖</p> <p>28: 10.3x ↘</p> <p>29: 10.5x ↗</p> <p>30: 10.4x ↗</p> <p>Serie 99.3</p> <p>Total 302.9</p>	<p>40 Skott</p>	<p>31: 9.5 →</p> <p>32: 10.5x ↗</p> <p>33: 10.7x ↓</p> <p>34: 10.1 ↓</p> <p>35: 10.6x ↘</p> <p>36: 10.3x →</p> <p>37: 10.0 ↗</p> <p>38: 10.3x ↓</p> <p>39: 10.2x ←</p> <p>40: 10.2x ↘</p> <p>Serie 102.4</p> <p>Total 405.3</p>

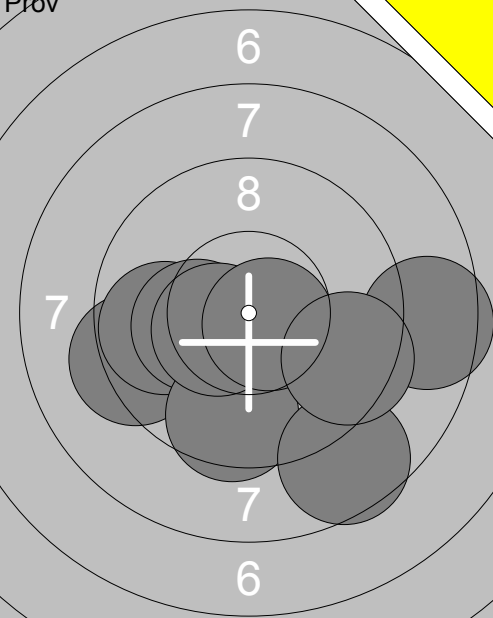
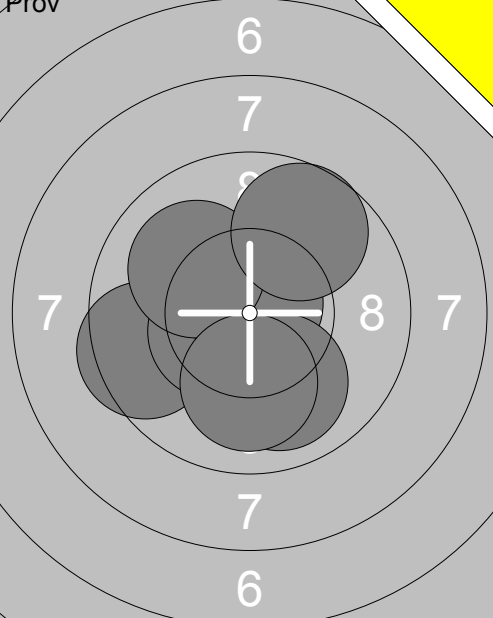
<p>Prov</p> 	<p>1: 8.5 →</p> <p>2: 9.3 ←</p> <p>3: 9.8 ←</p> <p>4: 10.2x ←</p> <p>5: 9.6 ↓</p> <p>7: 10.5x ←</p> <p>8: 8.6 ↓</p> <p>9: 10.6x →</p> <p>10: 9.5 →</p>	<p>Prov</p> 	<p>11: 9.5 ←</p> <p>12: 10.5x ←</p> <p>13: 10.8x ↗</p> <p>14: 10.0 ↓</p> <p>15: 10.1 ↖</p> <p>16: 9.7 ↗</p> <p>17: 10.0 ↓</p>
Serie 86.6		Serie 70.6	
Total 0.0		Total 0.0	

<p>40 Skott</p> 	<p>1: 10.6x ↓</p> <p>2: 10.6x ↓</p> <p>3: 10.2x ↖</p> <p>4: 8.6 ↗</p> <p>5: 10.0 ↖</p> <p>6: 10.4x →</p> <p>7: 9.2 →</p> <p>8: 9.6 ↗</p> <p>9: 10.7x ↓</p> <p>10: 10.5x →</p>	<p>40 Skott</p> 	<p>11: 9.8 ↖</p> <p>12: 10.7x ↖</p> <p>13: 9.8 ↖</p> <p>14: 10.1 →</p> <p>15: 7.5 ↓</p> <p>16: 9.5 ←</p> <p>17: 10.6x →</p> <p>18: 10.0 ↖</p> <p>19: 10.7x ↖</p> <p>20: 10.1 ↗</p>
Serie 100.4		Serie 98.8	
Total 100.4		Total 199.2	

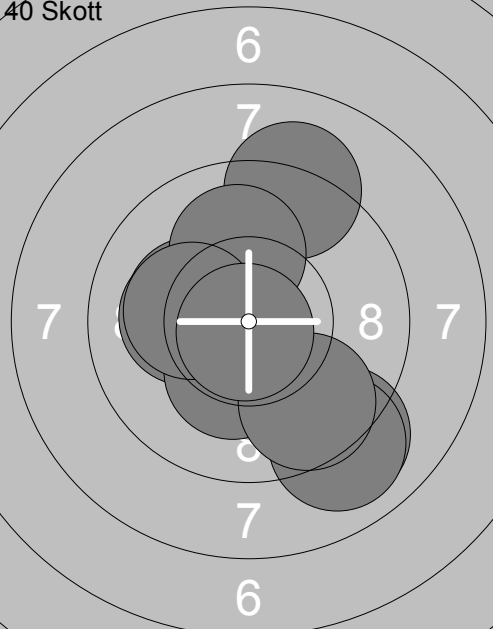
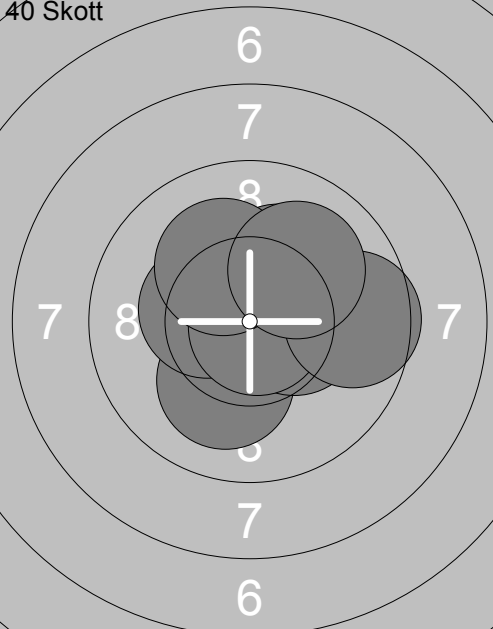
<p>40 Skott</p> 	<p>21: 9.1 ↗</p> <p>22: 9.0 ↓</p> <p>23: 10.2x ↖</p> <p>24: 10.1 ←</p> <p>25: 9.0 ↓</p> <p>26: 10.3x ↓</p> <p>27: 10.0 ↑</p> <p>28: 9.7 ↓</p> <p>29: 10.2x ↖</p> <p>30: 10.8x ↓</p>	<p>40 Skott</p> 	<p>31: 10.1 ↓</p> <p>32: 10.4x →</p> <p>33: 10.2x ↗</p> <p>34: 10.4x →</p> <p>35: 10.3x ↗</p> <p>36: 10.4x ↖</p> <p>37: 10.8x ↖</p> <p>38: 10.2x ↖</p> <p>39: 9.6 →</p> <p>40: 10.0 ↗</p>
Serie 98.4		Serie 102.4	
Total 297.6		Total 400.0	

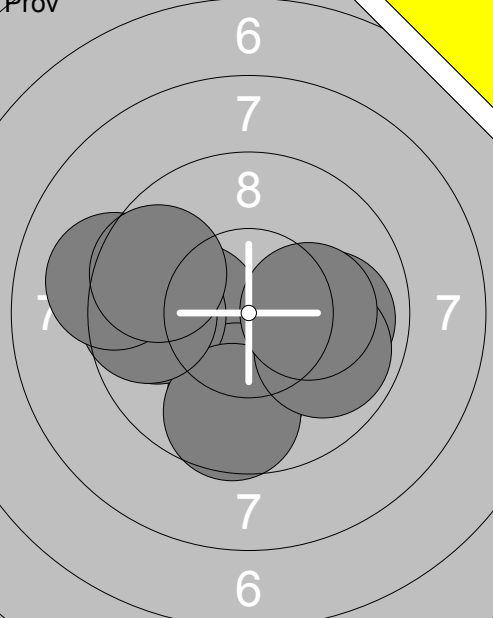
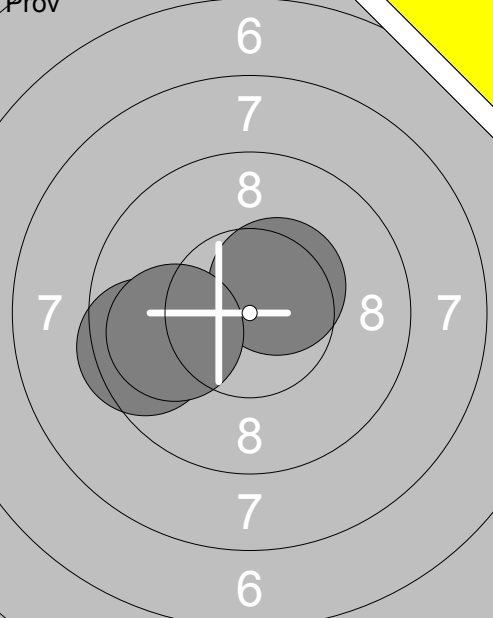
 <p style="text-align: center;">6 7 8 7 6</p>	<p>1: 10.2x ↗</p> <p>2: 9.9 ↓</p> <p>3: 9.9 →</p> <p>4: 9.8 ←</p> <p>5: 9.6 ↓</p> <p>6: 9.6 ←</p> <p>7: 9.9 ↗</p> <p>8: 9.1 ←</p> <p>9: 10.2x →</p> <p>10: 9.7 ←</p> <p>Serie 97.9</p> <p>Total 0.0</p>	 <p style="text-align: center;">6 7 8 7 6</p>	<p>11: 10.5x ↗</p> <p>12: 9.5 ←</p> <p>13: 9.9 ←</p> <p>Serie 29.9</p> <p>Total 0.0</p>
---	---	---	---

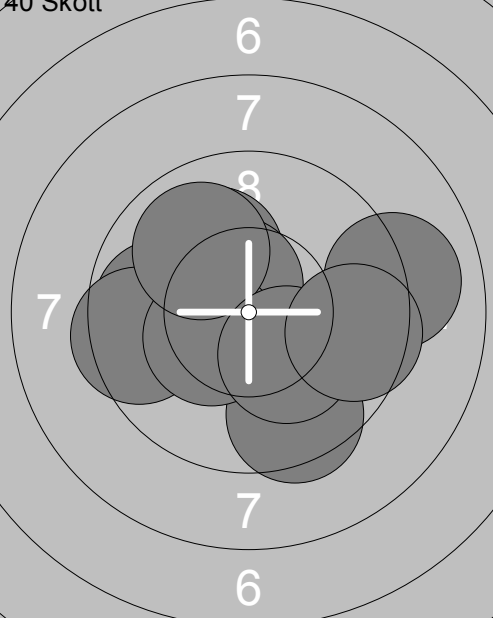
 <p style="text-align: center;">6 7 8 7 6</p>	<p>1: 10.1 ↗</p> <p>2: 9.8 ←</p> <p>3: 9.5 ↓</p> <p>4: 9.0 →</p> <p>5: 9.5 ←</p> <p>6: 10.5x ↗</p> <p>7: 10.4x ↗</p> <p>8: 9.9 ↗</p> <p>9: 10.2x ↘</p> <p>10: 9.6 →</p> <p>Serie 98.5</p> <p>Total 98.5</p>	 <p style="text-align: center;">6 7 8 7 6</p>	<p>11: 10.7x ↗</p> <p>12: 10.1 ↗</p> <p>13: 10.1 ↗</p> <p>14: 10.6x →</p> <p>15: 10.3x ↗</p> <p>16: 10.0 ↗</p> <p>17: 10.7x ↘</p> <p>18: 10.5x ↓</p> <p>19: 9.8 ↓</p> <p>20: 8.9 ↓</p> <p>Serie 101.7</p> <p>Total 200.2</p>
--	---	--	--

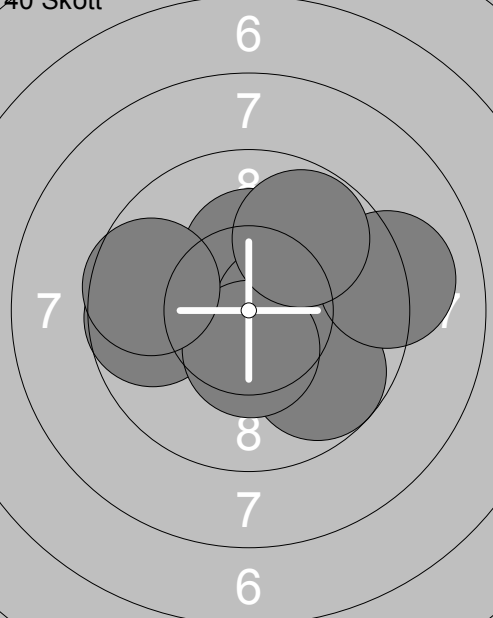
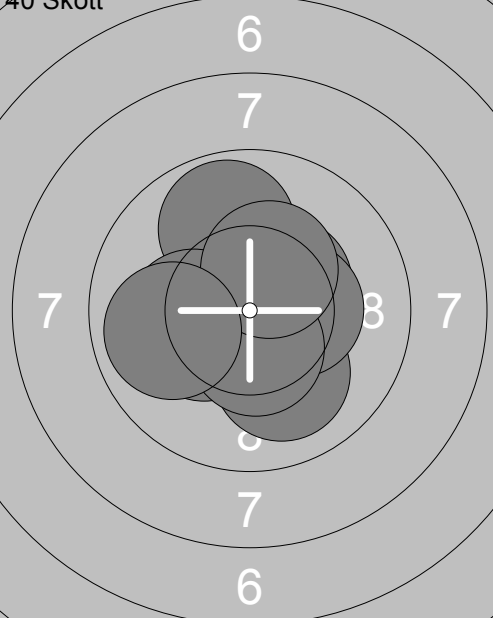
 <p style="text-align: center;">6 7 8 7 6</p>	<p>21: 9.7 →</p> <p>22: 10.3x ↗</p> <p>23: 10.0 →</p> <p>24: 9.7 ←</p> <p>25: 10.5x →</p> <p>26: 9.8 ↓</p> <p>27: 10.4x ↓</p> <p>28: 9.6 ←</p> <p>29: 9.1 →</p> <p>30: 9.8 ↗</p> <p>Serie 98.9</p> <p>Total 299.1</p>	 <p style="text-align: center;">6 7 8 7 6</p>	<p>31: 10.0 ↓</p> <p>32: 9.8 ↗</p> <p>33: 10.7x ↗</p> <p>34: 10.3x ↗</p> <p>35: 10.4x ↗</p> <p>36: 10.4x →</p> <p>37: 10.2x ↗</p> <p>38: 10.5x ↓</p> <p>39: 10.4x ↗</p> <p>40: 9.9 ←</p> <p>Serie 102.6</p> <p>Total 401.7</p>
---	---	---	--





<p>Prov</p>	<p>1: 9.1 ←</p> <p>2: 8.9 ↙</p> <p>3: 10.2x↑</p> <p>4: 10.1 ↗</p> <p>5: 10.0 →</p> <p>6: 9.2 →</p> <p>7: 10.1 ↑</p> <p>8: 9.6 →</p> <p>9: 10.4x↓</p> <p>10: 9.8 ↖</p> <p>Serie 97.4</p> <p>Total 0.0</p>	<p>Prov</p>	<p>11: 10.1 ↖</p> <p>12: 10.5x↙</p> <p>13: 10.8x↓</p> <p>Serie 31.4</p> <p>Total 0.0</p>
-------------	--	-------------	--

<p>40 Skott</p>	<p>1: 10.4x↑</p> <p>2: 9.5 ↗</p> <p>3: 10.4x↑</p> <p>4: 10.0 →</p> <p>5: 9.3 ↗</p> <p>6: 9.9 ←</p> <p>7: 9.9 ↘</p> <p>8: 10.2x↗</p> <p>9: 9.0 ←</p> <p>10: 10.0 ↙</p> <p>Serie 98.6</p> <p>Total 98.6</p>	<p>40 Skott</p>	<p>11: 9.2 ↓</p> <p>12: 10.0 →</p> <p>13: 9.9 →</p> <p>14: 9.7 →</p> <p>15: 10.4x↓</p> <p>16: 10.4x↘</p> <p>17: 10.5x↙</p> <p>18: 9.8 ←</p> <p>19: 10.0 ↙</p> <p>20: 9.1 ←</p> <p>Serie 99.0</p> <p>Total 197.6</p>
-----------------	---	-----------------	---

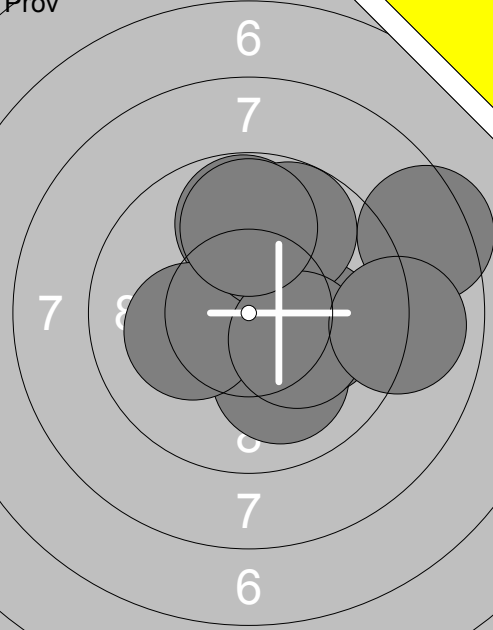
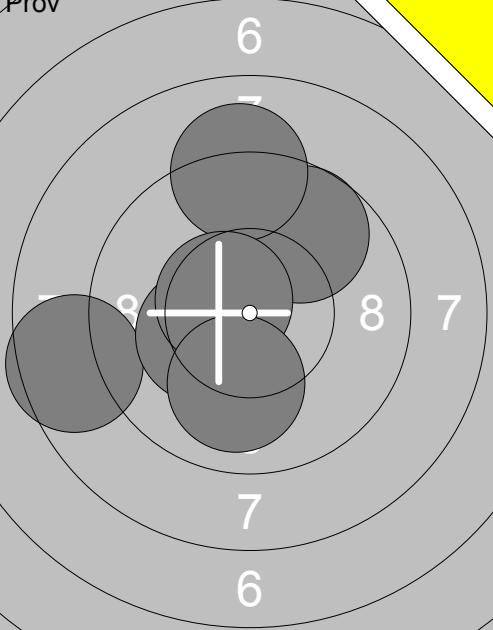
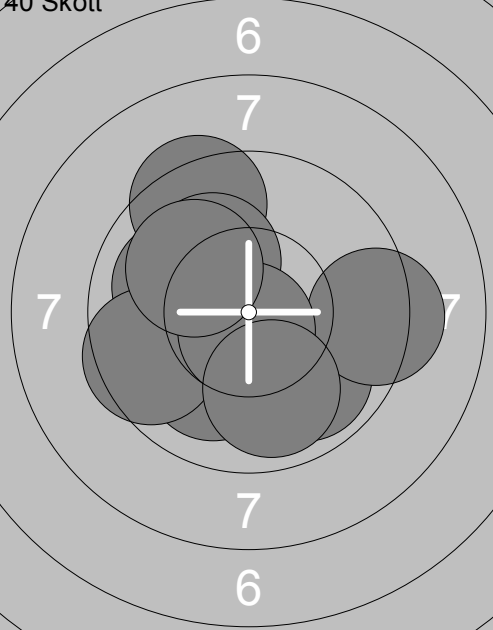
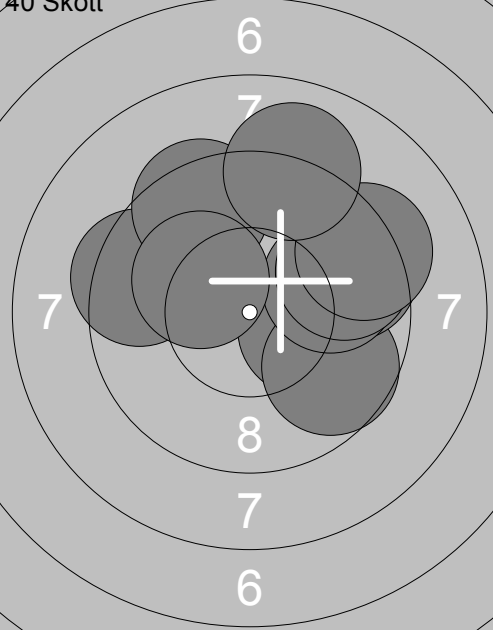
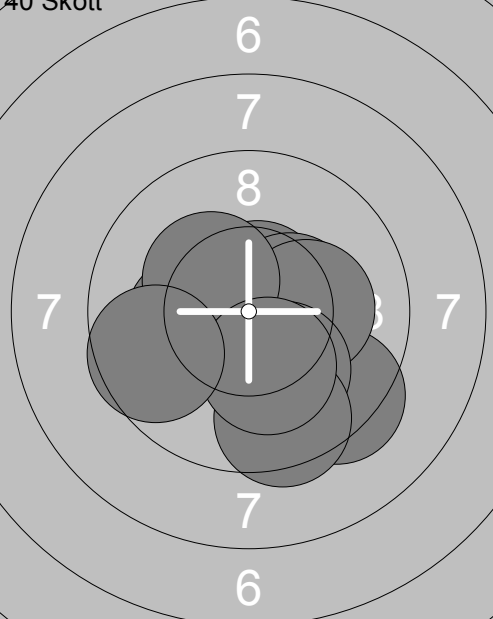
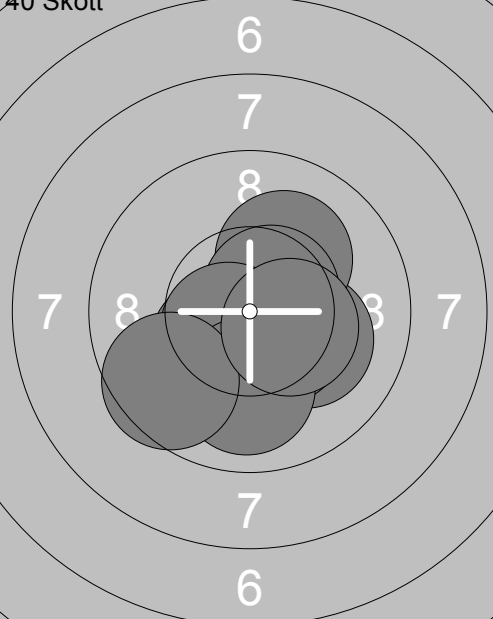
<p>40 Skott</p>	<p>21: 9.9 ↗</p> <p>22: 9.6 ←</p> <p>23: 9.9 ←</p> <p>24: 10.4x↖</p> <p>25: 10.3x↘</p> <p>26: 10.4x↙</p> <p>27: 10.1 ↑</p> <p>28: 10.5x↑</p> <p>29: 10.4x↓</p> <p>30: 10.6x↑</p> <p>Serie 102.1</p> <p>Total 299.7</p>	<p>40 Skott</p>	<p>31: 8.9 ↘</p> <p>32: 9.0 →</p> <p>33: 9.7 →</p> <p>34: 10.4x↓</p> <p>35: 10.1 ↓</p> <p>36: 9.6 →</p> <p>37: 10.7x↙</p> <p>38: 10.2x↙</p> <p>39: 10.6x↙</p> <p>40: 9.9 →</p> <p>Serie 99.1</p> <p>Total 398.8</p>
-----------------	--	-----------------	---

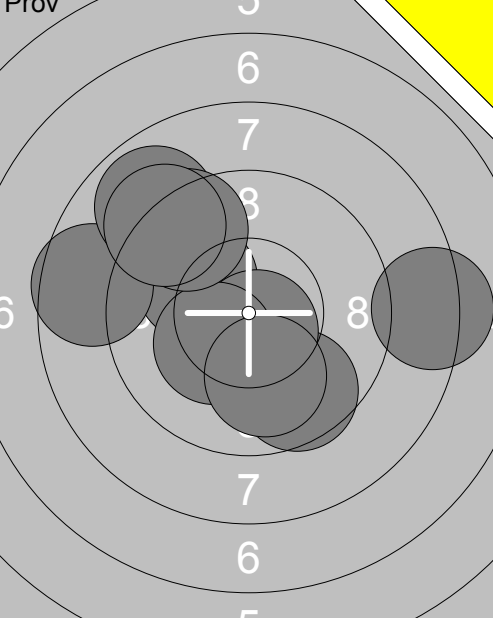
<div style="text-align: center;">  <p>Provschott</p> </div>	<div style="text-align: center;">  <p>Provschott</p> </div>	<table style="width:100%; border-collapse: collapse;"> <tr><td style="text-align: right;">11: 8.6</td><td style="text-align: left;">←</td></tr> <tr><td style="text-align: right;">12: 9.7</td><td style="text-align: left;">↗</td></tr> <tr><td style="text-align: right;">13: 10.3</td><td style="text-align: left;">✗</td></tr> <tr><td style="text-align: right;">14: 9.1</td><td style="text-align: left;">↑</td></tr> <tr><td style="text-align: right;">15: 10.6</td><td style="text-align: left;">✗</td></tr> <tr><td style="text-align: right;">16: 10.0</td><td style="text-align: left;">↓</td></tr> <tr><td colspan="2" style="border-top: 1px solid black;">Serie 58.3</td></tr> <tr><td colspan="2" style="border-top: 1px solid black;">Total 0.0</td></tr> </table>	11: 8.6	←	12: 9.7	↗	13: 10.3	✗	14: 9.1	↑	15: 10.6	✗	16: 10.0	↓	Serie 58.3		Total 0.0									
11: 8.6	←																									
12: 9.7	↗																									
13: 10.3	✗																									
14: 9.1	↑																									
15: 10.6	✗																									
16: 10.0	↓																									
Serie 58.3																										
Total 0.0																										
<div style="text-align: center;">  <p>40 Skott</p> </div>	<div style="text-align: center;">  <p>40 Skott</p> </div>	<table style="width:100%; border-collapse: collapse;"> <tr><td style="text-align: right;">11: 10.2</td><td style="text-align: left;">✗</td></tr> <tr><td style="text-align: right;">12: 9.7</td><td style="text-align: left;">↘</td></tr> <tr><td style="text-align: right;">13: 9.5</td><td style="text-align: left;">↗</td></tr> <tr><td style="text-align: right;">14: 9.8</td><td style="text-align: left;">↗</td></tr> <tr><td style="text-align: right;">15: 9.4</td><td style="text-align: left;">←</td></tr> <tr><td style="text-align: right;">16: 9.4</td><td style="text-align: left;">↑</td></tr> <tr><td style="text-align: right;">17: 9.6</td><td style="text-align: left;">↗</td></tr> <tr><td style="text-align: right;">18: 9.3</td><td style="text-align: left;">↗</td></tr> <tr><td style="text-align: right;">19: 9.0</td><td style="text-align: left;">↑</td></tr> <tr><td style="text-align: right;">20: 10.2</td><td style="text-align: left;">✗</td></tr> <tr><td colspan="2" style="border-top: 1px solid black;">Serie 96.1</td></tr> <tr><td colspan="2" style="border-top: 1px solid black;">Total 195.0</td></tr> </table>	11: 10.2	✗	12: 9.7	↘	13: 9.5	↗	14: 9.8	↗	15: 9.4	←	16: 9.4	↑	17: 9.6	↗	18: 9.3	↗	19: 9.0	↑	20: 10.2	✗	Serie 96.1		Total 195.0	
11: 10.2	✗																									
12: 9.7	↘																									
13: 9.5	↗																									
14: 9.8	↗																									
15: 9.4	←																									
16: 9.4	↑																									
17: 9.6	↗																									
18: 9.3	↗																									
19: 9.0	↑																									
20: 10.2	✗																									
Serie 96.1																										
Total 195.0																										
<div style="text-align: center;">  <p>40 Skott</p> </div>	<div style="text-align: center;">  <p>40 Skott</p> </div>	<table style="width:100%; border-collapse: collapse;"> <tr><td style="text-align: right;">21: 10.6</td><td style="text-align: left;">✗</td></tr> <tr><td style="text-align: right;">22: 9.4</td><td style="text-align: left;">↘</td></tr> <tr><td style="text-align: right;">23: 10.4</td><td style="text-align: left;">✗</td></tr> <tr><td style="text-align: right;">24: 10.2</td><td style="text-align: left;">✗</td></tr> <tr><td style="text-align: right;">25: 10.2</td><td style="text-align: left;">✗</td></tr> <tr><td style="text-align: right;">26: 10.1</td><td style="text-align: left;">↓</td></tr> <tr><td style="text-align: right;">27: 10.3</td><td style="text-align: left;">✗</td></tr> <tr><td style="text-align: right;">28: 9.5</td><td style="text-align: left;">↓</td></tr> <tr><td style="text-align: right;">29: 10.2</td><td style="text-align: left;">✗</td></tr> <tr><td style="text-align: right;">30: 9.6</td><td style="text-align: left;">←</td></tr> <tr><td colspan="2" style="border-top: 1px solid black;">Serie 100.5</td></tr> <tr><td colspan="2" style="border-top: 1px solid black;">Total 295.5</td></tr> </table>	21: 10.6	✗	22: 9.4	↘	23: 10.4	✗	24: 10.2	✗	25: 10.2	✗	26: 10.1	↓	27: 10.3	✗	28: 9.5	↓	29: 10.2	✗	30: 9.6	←	Serie 100.5		Total 295.5	
21: 10.6	✗																									
22: 9.4	↘																									
23: 10.4	✗																									
24: 10.2	✗																									
25: 10.2	✗																									
26: 10.1	↓																									
27: 10.3	✗																									
28: 9.5	↓																									
29: 10.2	✗																									
30: 9.6	←																									
Serie 100.5																										
Total 295.5																										
<div style="text-align: center;">  <p>40 Skott</p> </div>	<div style="text-align: center;">  <p>40 Skott</p> </div>	<table style="width:100%; border-collapse: collapse;"> <tr><td style="text-align: right;">31: 10.1</td><td style="text-align: left;">↘</td></tr> <tr><td style="text-align: right;">32: 10.1</td><td style="text-align: left;">↗</td></tr> <tr><td style="text-align: right;">33: 10.3</td><td style="text-align: left;">✗</td></tr> <tr><td style="text-align: right;">34: 10.5</td><td style="text-align: left;">✗</td></tr> <tr><td style="text-align: right;">35: 10.1</td><td style="text-align: left;">↓</td></tr> <tr><td style="text-align: right;">36: 10.6</td><td style="text-align: left;">✗</td></tr> <tr><td style="text-align: right;">37: 10.6</td><td style="text-align: left;">✗</td></tr> <tr><td style="text-align: right;">38: 10.0</td><td style="text-align: left;">↓</td></tr> <tr><td style="text-align: right;">39: 9.6</td><td style="text-align: left;">←</td></tr> <tr><td style="text-align: right;">40: 10.4</td><td style="text-align: left;">✗</td></tr> <tr><td colspan="2" style="border-top: 1px solid black;">Serie 102.3</td></tr> <tr><td colspan="2" style="border-top: 1px solid black;">Total 397.8</td></tr> </table>	31: 10.1	↘	32: 10.1	↗	33: 10.3	✗	34: 10.5	✗	35: 10.1	↓	36: 10.6	✗	37: 10.6	✗	38: 10.0	↓	39: 9.6	←	40: 10.4	✗	Serie 102.3		Total 397.8	
31: 10.1	↘																									
32: 10.1	↗																									
33: 10.3	✗																									
34: 10.5	✗																									
35: 10.1	↓																									
36: 10.6	✗																									
37: 10.6	✗																									
38: 10.0	↓																									
39: 9.6	←																									
40: 10.4	✗																									
Serie 102.3																										
Total 397.8																										

 <p>Prov</p>	<p>1: 10.1 ↖</p> <p>2: 8.2 →</p> <p>3: 8.6 ←</p> <p>4: 9.6 ↘</p> <p>5: 10.7x ↘</p> <p>6: 10.3x ↘</p> <p>7: 10.0 ↓</p> <p>8: 8.9 ↗</p> <p>9: 9.4 ↗</p> <p>10: 9.2 ↗</p>	 <p>Prov</p>	<p>11: 9.4 ↑</p> <p>12: 10.0 ↗</p> <p>13: 6.8 ←</p> <p>14: 9.9 →</p> <p>15: 9.7 ↑</p>
Serie	95.0	Serie	45.8
Total	0.0	Total	0.0

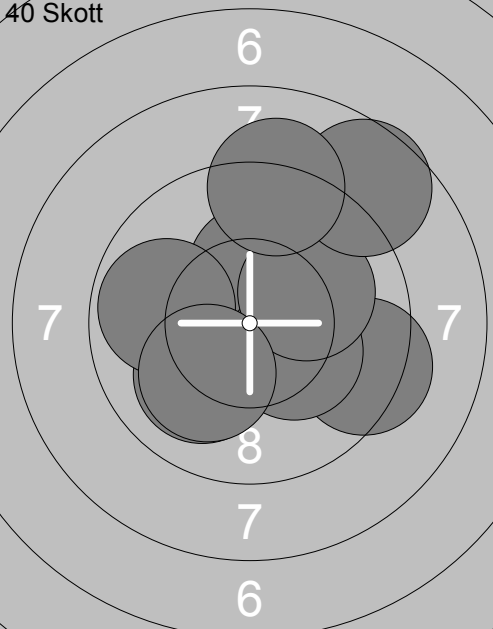
 <p>40 Skott</p>	<p>1: 10.3x ↖</p> <p>2: 9.1 →</p> <p>3: 9.1 ↗</p> <p>4: 8.2 ←</p> <p>5: 8.8 →</p> <p>6: 10.6x →</p> <p>7: 10.2x →</p> <p>8: 10.4x ↗</p> <p>9: 10.1 ↖</p> <p>10: 9.6 ↗</p>	 <p>40 Skott</p>	<p>11: 10.0 ↖</p> <p>12: 9.4 →</p> <p>13: 10.4x ↘</p> <p>14: 10.3x ↗</p> <p>15: 10.3x ↘</p> <p>16: 10.1 ↗</p> <p>17: 8.6 ↗</p> <p>18: 9.8 ←</p> <p>19: 9.1 ↑</p> <p>20: 10.1 ↖</p>
Serie	96.4	Serie	98.1
Total	96.4	Total	194.5

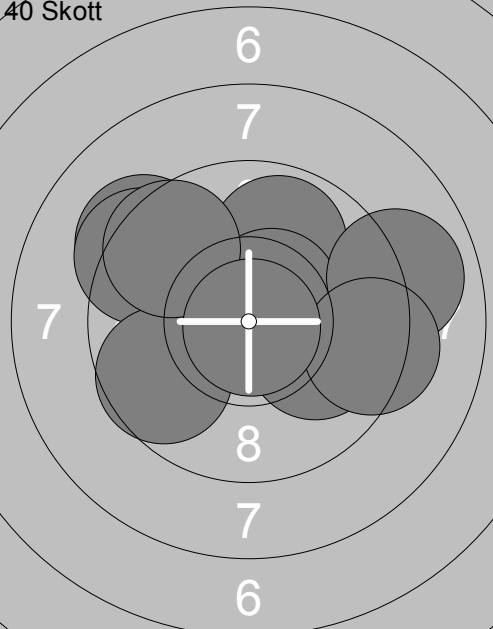
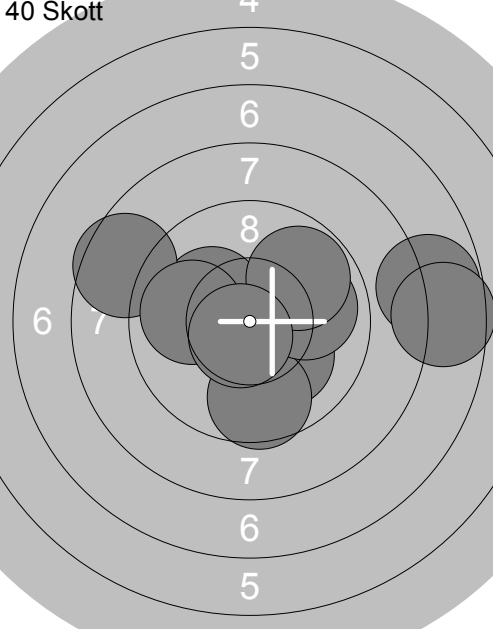
 <p>40 Skott</p>	<p>21: 9.9 ↑</p> <p>22: 10.0 →</p> <p>23: 10.5x ↗</p> <p>24: 9.2 ↖</p> <p>25: 9.0 →</p> <p>26: 9.3 →</p> <p>27: 9.3 ↖</p> <p>28: 9.6 ↖</p> <p>29: 9.6 ↖</p> <p>30: 10.9x ↘</p>	 <p>40 Skott</p>	<p>31: 10.2x ↖</p> <p>32: 10.1 ↘</p> <p>33: 9.6 ↓</p> <p>34: 7.8 →</p> <p>35: 10.0 →</p> <p>36: 8.6 ←</p> <p>37: 9.9 ←</p> <p>38: 9.8 ↗</p> <p>39: 10.7x ↘</p> <p>40: 7.6 →</p>
Serie	97.3	Serie	94.3
Total	291.8	Total	386.1

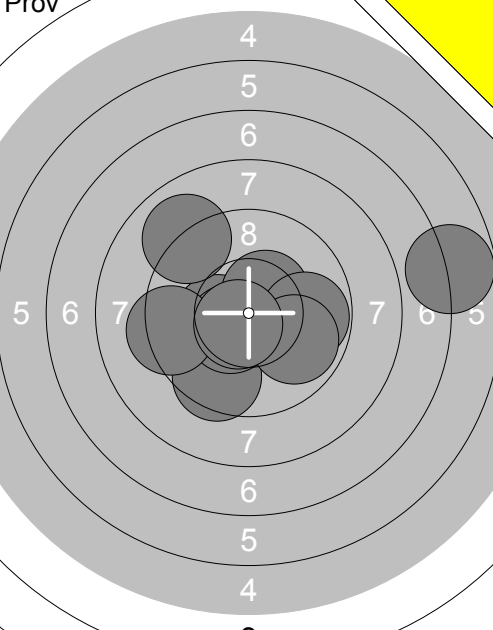
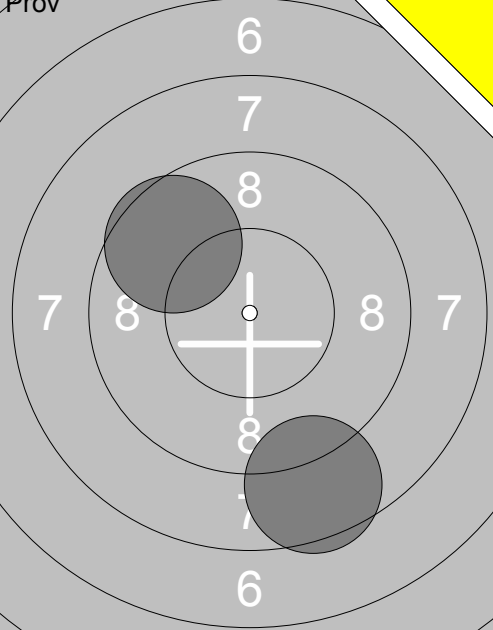
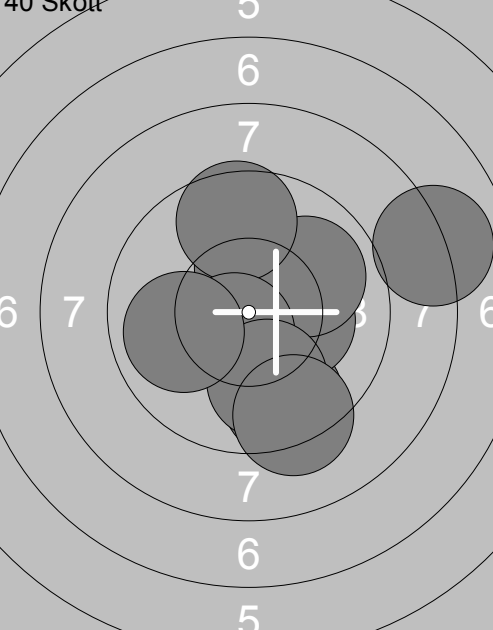
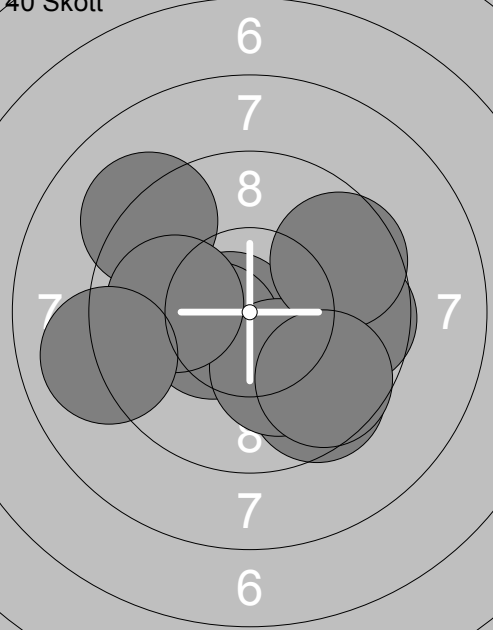
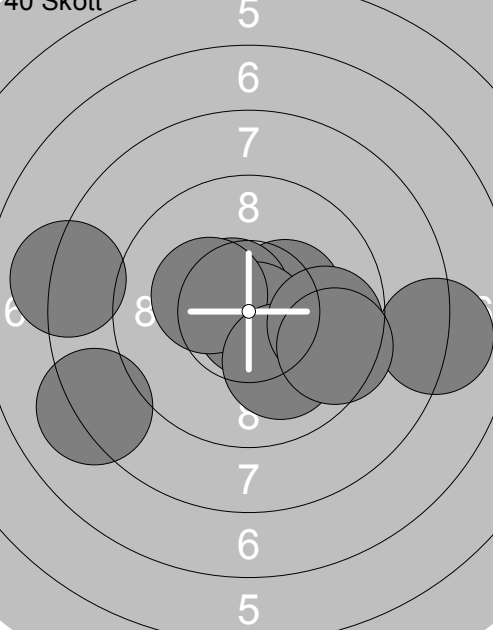
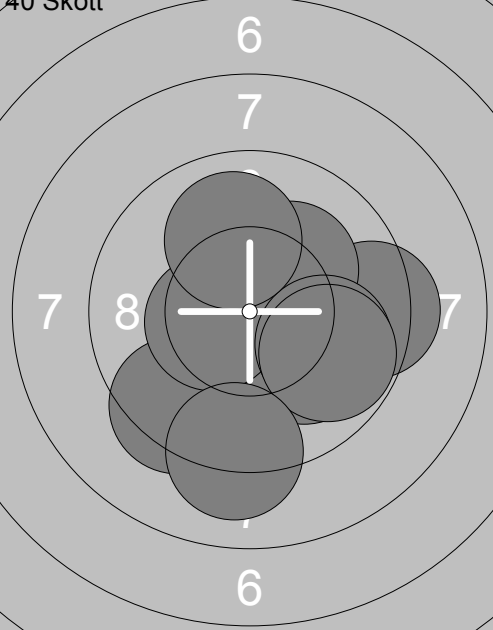
 <p style="font-size: small;">Prov</p>	<p>1: 9.5 ↘</p> <p>2: 10.3x ↗</p> <p>3: 10.5x ↘</p> <p>4: 9.3 ←</p> <p>5: 10.4x ↗</p> <p>6: 9.0 ↗</p> <p>7: 9.8 →</p> <p>8: 9.9 ↘</p> <p>9: 10.6x ↘</p> <p>10: 6.8 →</p> <p>Serie 96.1</p> <p>Total 0.0</p>	 <p style="font-size: small;">Prov</p>	<p>11: 9.6 ↗</p> <p>12: 8.6 ↘</p> <p>Serie 18.2</p> <p>Total 0.0</p>
<p>40 Skott</p> 	<p>1: 8.0 →</p> <p>2: 10.3x ↗</p> <p>3: 9.6 ↘</p> <p>4: 10.3x ↗</p> <p>5: 10.0 ↗</p> <p>6: 9.6 ↑</p> <p>7: 10.6x ↘</p> <p>8: 9.9 ↘</p> <p>9: 9.9 ←</p> <p>10: 9.3 ↘</p> <p>Serie 97.5</p> <p>Total 97.5</p>	<p>40 Skott</p> 	<p>11: 9.2 ↖</p> <p>12: 10.7x ↘</p> <p>13: 10.4x ↘</p> <p>14: 9.6 ↘</p> <p>15: 9.7 →</p> <p>16: 10.1 ↘</p> <p>17: 10.0 ←</p> <p>18: 9.6 ↗</p> <p>19: 9.6 ↘</p> <p>20: 9.0 ←</p> <p>Serie 97.9</p> <p>Total 195.4</p>
<p>40 Skott</p> 	<p>21: 10.4x ↗</p> <p>22: 10.6x ↘</p> <p>23: 10.8x ↘</p> <p>24: 8.0 →</p> <p>25: 8.2 ←</p> <p>26: 10.3x ↘</p> <p>27: 8.1 ←</p> <p>28: 10.0 ↘</p> <p>29: 9.8 →</p> <p>30: 9.5 ↗</p> <p>Serie 95.7</p> <p>Total 291.1</p>	<p>40 Skott</p> 	<p>31: 10.3x ↘</p> <p>32: 9.4 ↘</p> <p>33: 10.0 ↘</p> <p>34: 9.4 →</p> <p>35: 10.2x ↗</p> <p>36: 10.5x ↘</p> <p>37: 9.9 ↗</p> <p>38: 9.8 ↗</p> <p>39: 10.0 ↑</p> <p>40: 9.1 ↘</p> <p>Serie 98.6</p> <p>Total 389.7</p>

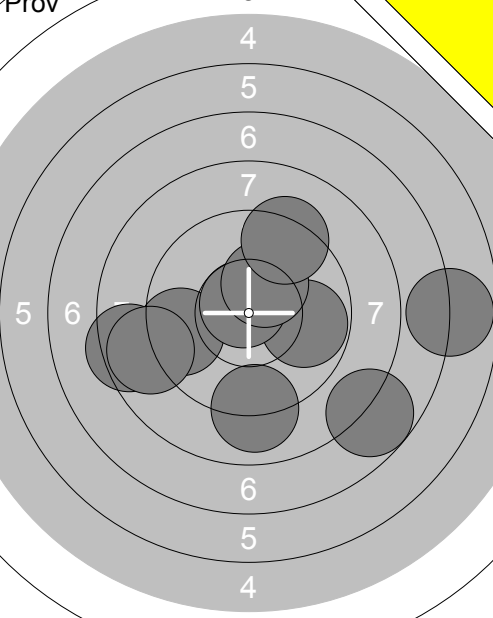
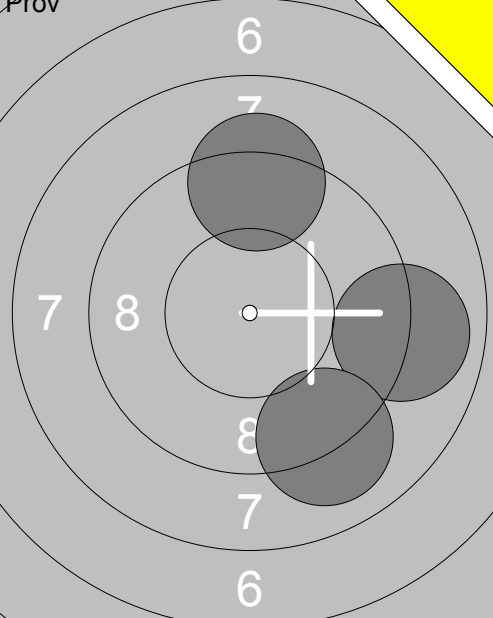
	<p>Prov</p> <p>1: 8.4 ←</p> <p>2: 9.8 →</p> <p>3: 9.5 ←</p> <p>4: 8.8 ←</p> <p>5: 10.7x ↘</p> <p>6: 10.3x ↗</p> <p>7: 7.7 ↘</p> <p>8: 6.8 →</p> <p>9: 9.3 ↗</p> <p>10: 9.0 ↓</p> <p>Serie 90.3</p> <p>Total 0.0</p>		<p>11: 9.0 →</p> <p>12: 9.1 ↘</p> <p>13: 9.2 ↑</p> <p>Serie 27.3</p> <p>Total 0.0</p>
--	---	--	---

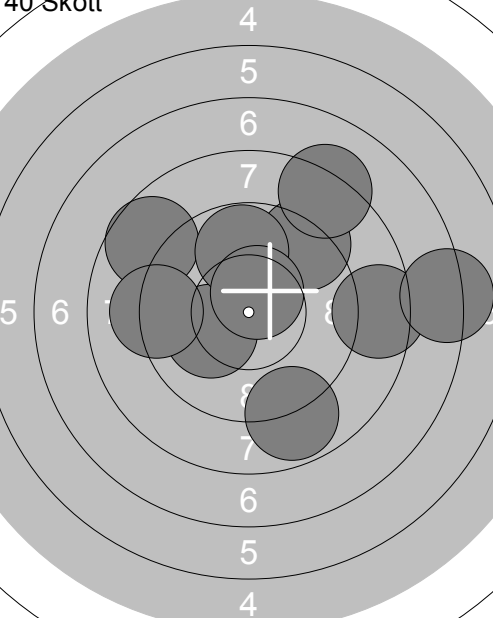
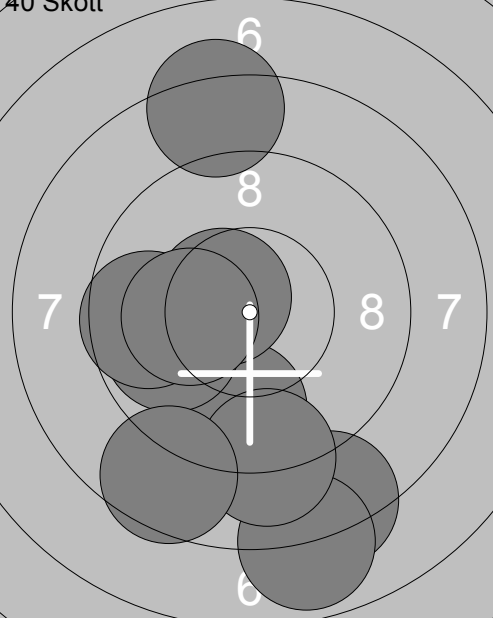
<p>40 Skott</p> 	<p>1: 8.8 ↓</p> <p>2: 8.5 →</p> <p>3: 8.7 ↖</p> <p>4: 10.1 ←</p> <p>5: 9.3 ↗</p> <p>6: 9.8 ↑</p> <p>7: 10.5x ↗</p> <p>8: 8.2 ↗</p> <p>9: 7.1 →</p> <p>10: 9.2 ←</p> <p>Serie 90.2</p> <p>Total 90.2</p>	<p>40 Skott</p> 	<p>11: 9.7 ↓</p> <p>12: 9.9 ←</p> <p>13: 10.5x ↖</p> <p>14: 8.3 ↓</p> <p>15: 7.9 ↓</p> <p>16: 9.0 ↓</p> <p>17: 8.6 ↓</p> <p>18: 9.6 ←</p> <p>19: 10.2x ↖</p> <p>20: 8.2 ↑</p> <p>Serie 91.9</p> <p>Total 182.1</p>
---	---	---	--

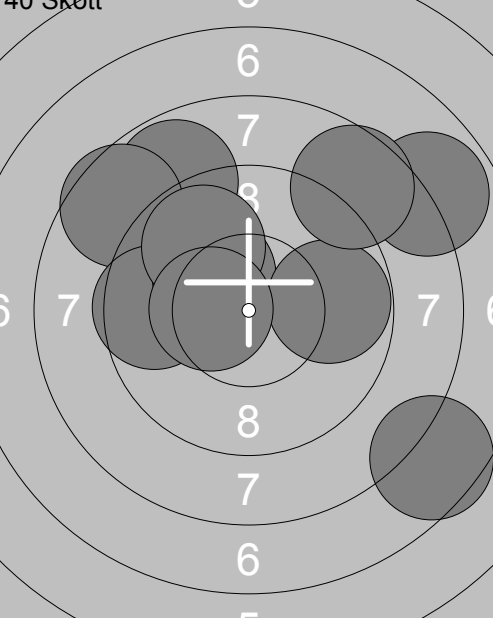
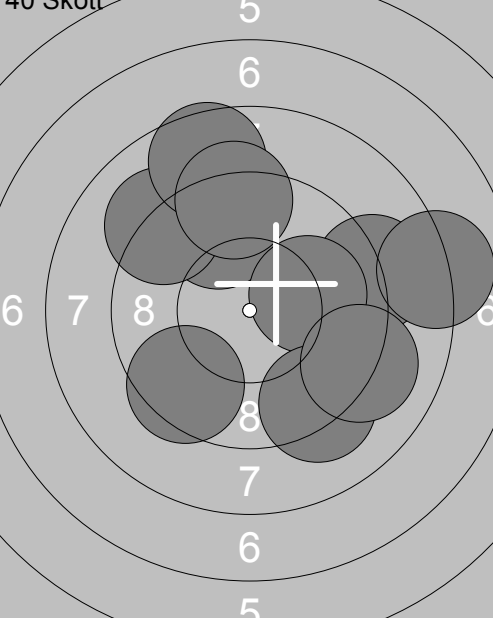
<p>40 Skott</p> 	<p>21: 8.8 ↗</p> <p>22: 8.6 ↖</p> <p>23: 9.6 ←</p> <p>24: 7.6 ↘</p> <p>25: 10.2x ↖</p> <p>26: 9.8 ↗</p> <p>27: 9.8 →</p> <p>28: 10.4x ↖</p> <p>29: 7.9 ↗</p> <p>30: 8.6 ↗</p> <p>Serie 91.3</p> <p>Total 273.4</p>	<p>40 Skott</p> 	<p>31: 9.7 ↑</p> <p>32: 9.0 →</p> <p>33: 10.0 →</p> <p>34: 9.1 ↖</p> <p>35: 8.6 ↑</p> <p>36: 8.1 →</p> <p>37: 9.2 ↓</p> <p>38: 9.1 ↘</p> <p>39: 9.3 ↑</p> <p>40: 9.5 ↘</p> <p>Serie 91.6</p> <p>Total 365.0</p>
--	--	--	---

<p><b>Prov</b></p>	<p>1: 10.4x ↘ 2: 9.1 → 3: 10.8x ↘ 4: 9.7 ↙ 5: 10.3x ↘ 6: 10.5x ↗ 7: 10.0 ↗ 8: 9.3 ↙ 9: 9.8 ↑ 10: 10.2x →</p> <p>Serie 100.1 Total 0.0</p>	<p><b>Prov</b></p>	<p>11: 9.7 ↗ 12: 10.0 ↗</p> <p>Serie 19.7 Total 0.0</p>
<p><b>40 Skott</b></p>	<p>1: 10.5x ↘ 2: 10.6x ↗ 3: 10.0 ↑ 4: 9.7 ↑ 5: 10.2x ↘ 6: 10.0 ↓ 7: 9.2 → 8: 10.2x ↘ 9: 8.9 → 10: 9.5 ↗</p> <p>Serie 98.8 Total 98.8</p>	<p><b>40 Skott</b></p>	<p>11: 9.1 ↙ 12: 10.2x → 13: 9.9 ↗ 14: 9.3 ↙ 15: 10.9x → 16: 10.1 → 17: 10.1 ↘ 18: 10.1 ↗ 19: 8.7 → 20: 10.2x ↘</p> <p>Serie 98.6 Total 197.4</p>
<p><b>40 Skott</b></p>	<p>21: 9.7 ↑ 22: 10.5x ↗ 23: 9.2 → 24: 10.3x ↘ 25: 9.8 ↓ 26: 9.7 ↓ 27: 8.8 → 28: 10.1 ↘ 29: 10.2x ↗ 30: 10.3x ↘</p> <p>Serie 98.6 Total 296.0</p>	<p><b>40 Skott</b></p>	<p>31: 9.8 ↙ 32: 9.3 ↓ 33: 10.0 ↗ 34: 10.3x ↗ 35: 10.1 → 36: 9.8 → 37: 9.1 ↘ 38: 10.0 ↙ 39: 10.0 → 40: 9.5 ↙</p> <p>Serie 97.9 Total 393.9</p>

<p>Pröv</p>	<p>1: 10.1 →</p> <p>2: 9.2 ↗</p> <p>3: 8.3 ↘</p> <p>4: 10.2x↓</p> <p>5: 10.4x→</p> <p>6: 9.0 ←</p> <p>7: 8.5 →</p> <p>8: 9.8 ←</p> <p>9: 9.0 →</p> <p>10: 9.7 ←</p> <p>Serie 94.2</p> <p>Total 0.0</p>	<p>Pröv</p>	<p>11: 10.7x↓</p> <p>12: 10.5x↘</p> <p>13: 9.8 ↗</p> <p>14: 9.7 →</p> <p>15: 9.6 ↗</p> <p>16: 8.8 ↓</p> <p>Serie 59.1</p> <p>Total 0.0</p>
-------------	--	-------------	--

<p>40 Skott</p>	<p>1: 10.6x↗</p> <p>2: 10.3x↘</p> <p>3: 8.8 ↗</p> <p>4: 9.6 ↑</p> <p>5: 10.4x↘</p> <p>6: 9.1 ←</p> <p>7: 9.7 ↗</p> <p>8: 10.6x↘</p> <p>9: 10.8x↘</p> <p>10: 10.0 ↗</p> <p>Serie 99.9</p> <p>Total 99.9</p>	<p>40 Skott</p>	<p>11: 10.0 →</p> <p>12: 9.5 ↗</p> <p>13: 9.8 ←</p> <p>14: 9.2 ↘</p> <p>15: 9.7 →</p> <p>16: 9.6 ↓</p> <p>17: 10.3x↘</p> <p>18: 10.7x↘</p> <p>19: 10.2x→</p> <p>20: 10.6x→</p> <p>Serie 99.6</p> <p>Total 199.5</p>
-----------------	--	-----------------	---

<p>40 Skott</p>	<p>21: 10.4x↘</p> <p>22: 9.8 ↓</p> <p>23: 10.1 ↗</p> <p>24: 9.5 ←</p> <p>25: 10.0 ↑</p> <p>26: 8.7 →</p> <p>27: 9.2 ←</p> <p>28: 9.7 →</p> <p>29: 10.7x↗</p> <p>30: 9.7 ↗</p> <p>Serie 97.8</p> <p>Total 297.3</p>	<p>40 Skott</p>	<p>31: 9.2 →</p> <p>32: 9.7 ↘</p> <p>33: 9.2 →</p> <p>34: 9.6 →</p> <p>35: 9.5 ↘</p> <p>36: 10.4x↘</p> <p>37: 9.5 ↓</p> <p>38: 8.8 ←</p> <p>39: 8.7 ←</p> <p>40: 9.9 ↗</p> <p>Serie 94.5</p> <p>Total 391.8</p>
-----------------	--	-----------------	---

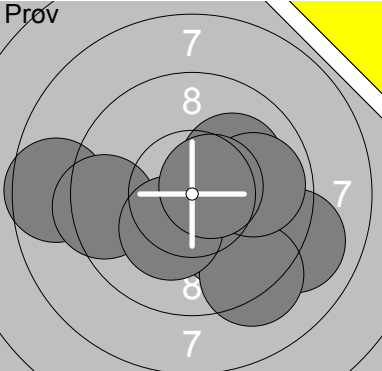
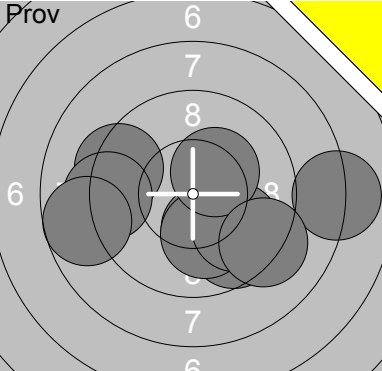
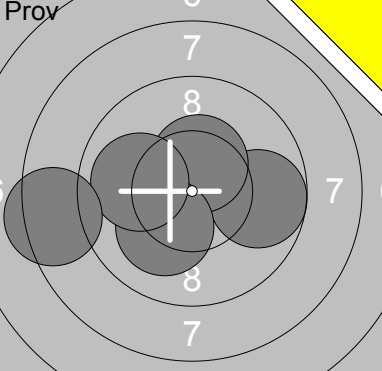
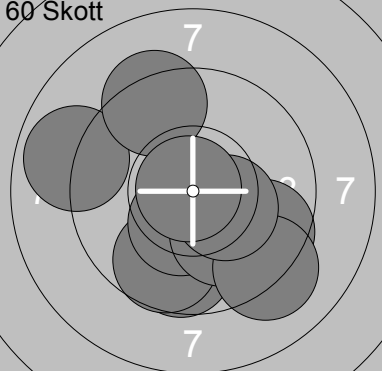
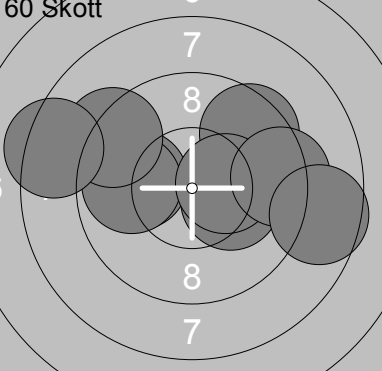
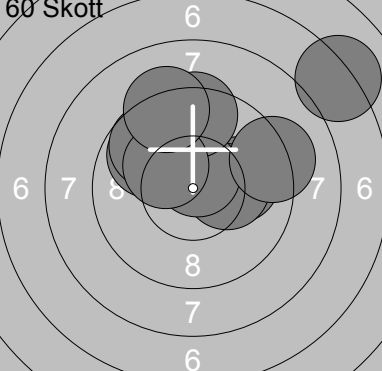
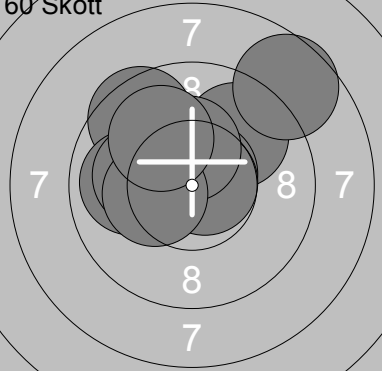
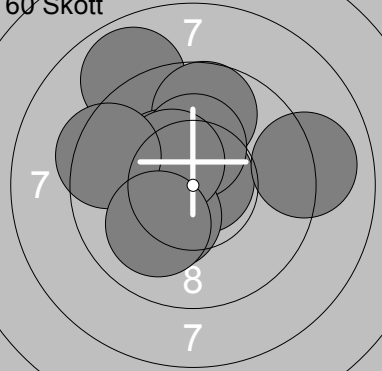
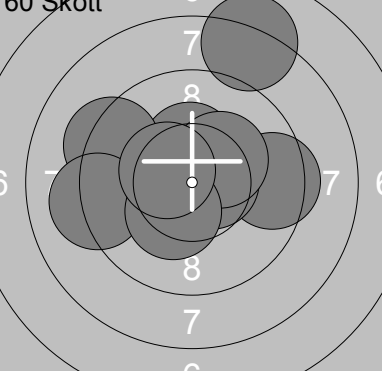
Skjutlag	Tavla	Vincent Stridsson	
3	7		
Vindeln	Gällivare		No
18.03.2017	SM & JSM Luftgevär 2017	Ramselefors SKF	
	1: 8.6 ←		11: 10.2x ↓
	2: 9.0 →		12: 9.4 ↗
	3: 10.2x →		13: 9.7 ↓
	4: 10.0 ↓		14: 8.0 →
	5: 9.2 ↓		15: 10.1 ↓
	6: 10.1 →		16: 9.2 ←
	7: 9.9 →		17: 8.7 ←
	8: 9.4 ←		18: 9.8 ↓
	9: 10.3x ↓		19: 10.3x ↗
	10: 10.6x →		20: 9.2 ↓
	Serie 97.3		Serie 94.6
	Total 0.0		Total 0.0
	21: 9.7 →		1: 8.9 ←
	22: 10.4x ↑		2: 9.6 ↓
	23: 10.1 ↓		3: 9.7 ↓
	24: 10.0 ←		4: 9.7 ↓
	25: 8.4 ←		5: 10.4x ↓
	Serie 48.6		Serie 98.1
	Total 0.0		Total 98.1
	11: 10.0 ←		21: 7.1 ↗
	12: 10.2x →		22: 10.0 →
	13: 9.9 ←		23: 9.8 ↗
	14: 10.2x →		24: 10.2x →
	15: 9.5 ↗		25: 10.6x ↑
	16: 9.2 ↗		26: 9.7 ↗
	17: 8.3 ←		27: 9.4 ↑
	18: 10.3x →		28: 10.2x ↗
	19: 9.3 →		29: 9.2 →
	20: 8.6 →		30: 9.2 ↑
	Serie 95.5		Serie 95.4
	Total 193.6		Total 289.0
	31: 9.5 ↗		41: 8.9 ↗
	32: 9.8 ↗		42: 10.8x ↗
	33: 9.9 ←		43: 9.7 ↑
	34: 10.7x ↗		44: 10.3x ↗
	35: 10.7x →		45: 10.3x ↑
	36: 10.3x ↑		46: 10.3x ↓
	37: 10.1 ←		47: 10.4x ↗
	38: 10.3x ←		48: 9.4 ←
	39: 8.6 ↗		49: 10.1 ↓
	40: 10.0 ↗		50: 9.0 →
	Serie 99.9		Serie 99.2
	Total 388.9		Total 488.1
	51: 10.6x ↑		
	52: 10.4x ↑		
	53: 9.3 ←		
	54: 9.5 →		
	55: 9.1 ←		
	56: 8.1 ↑		
	57: 10.6x →		
	58: 10.3x ↗		
	59: 10.3x ↓		
	60: 10.4x ←		
	Serie 98.6		
	Total 586.7		

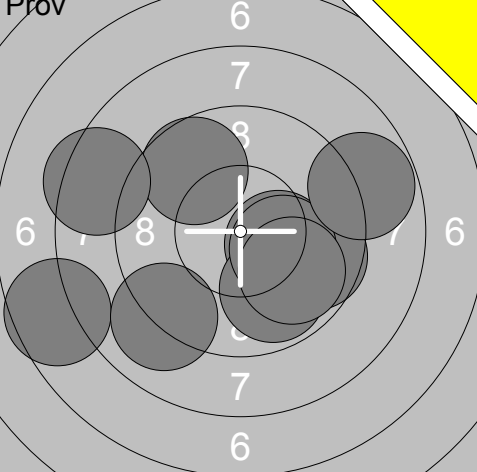
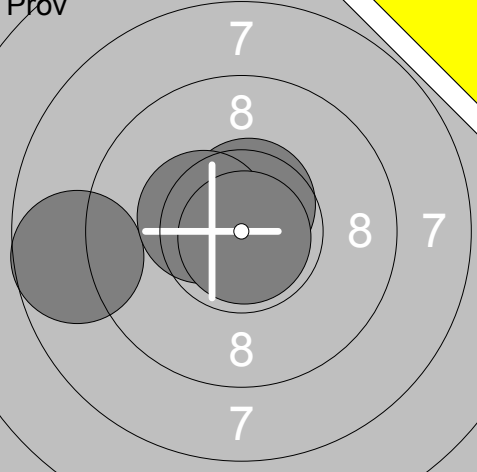
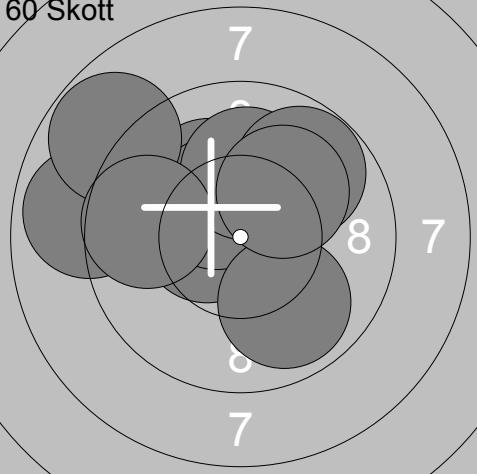
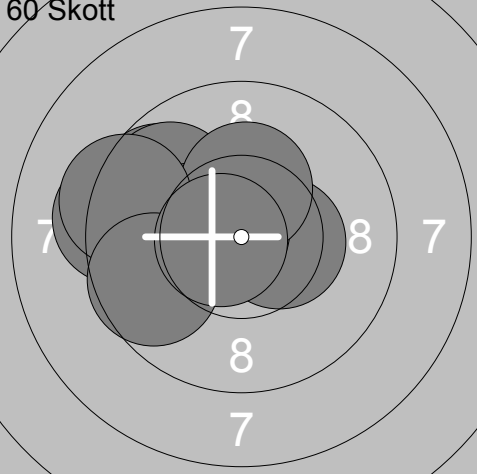
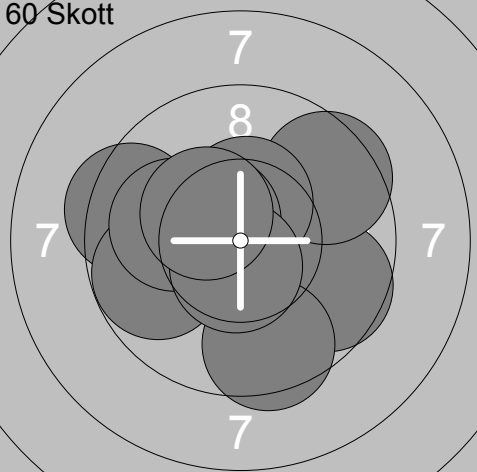
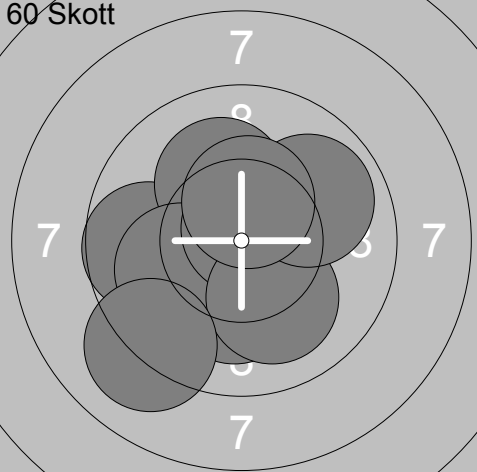
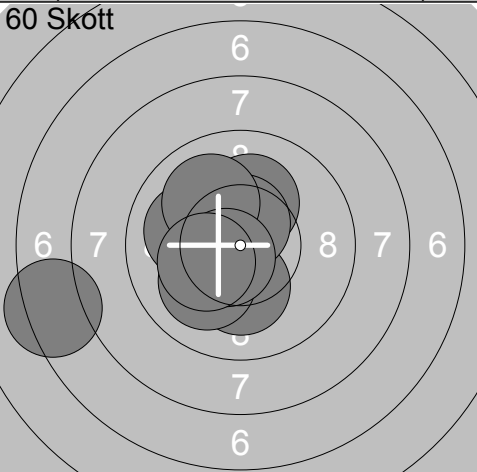
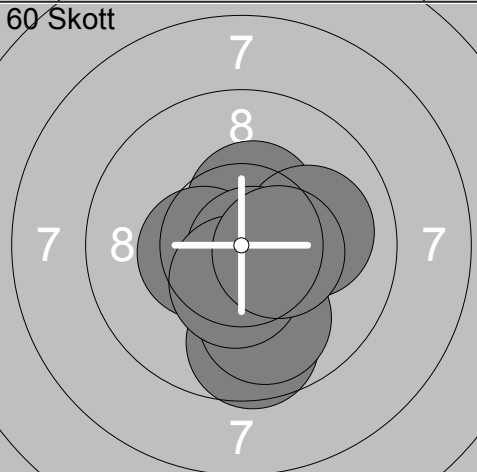

Skjuttag	Tavla	Eddie Linander	
3	8		
Vindeln	Gefle Frivilliga Skarp		Gä
18.03.2017	SM & JSM Luftgevär 2017	Ramselefors SKF	
<b>Prov</b> 	1: 9.1 ↑ 2: 9.3 ← 3: 8.9 ↑ 4: 7.6 ← 5: 10.4x ← 6: 9.1 ↑ 7: 9.6 → 8: 6.4 ↑ 9: 8.9 ← 10: 9.7 ← Serie 89.0 Total 0.0	<b>Prov</b> 	11: 6.6 ↖ 12: 9.1 ↗ 13: 9.5 ↗ 14: 9.2 ← 15: 9.5 ← 16: 8.6 ↘ 17: 9.4 → 18: 10.3x ↗ Serie 72.2 Total 0.0
<b>60 Skott</b> 	1: 10.7x ↗ 2: 9.4 ↗ 3: 10.0 → 4: 10.6x ↓ 5: 9.3 ← 6: 10.5x ↗ 7: 8.9 ← 8: 10.5x ↗ 9: 9.7 ↑ 10: 10.7x ↓ Serie 100.3 Total 100.3	<b>60 Skott</b> 	11: 8.3 ← 12: 8.7 ← 13: 9.4 ↑ 14: 9.6 ↓ 15: 9.0 ← 16: 8.8 ↓ 17: 8.4 ↗ 18: 8.9 ↓ 19: 8.5 ← 20: 9.3 → Serie 88.9 Total 189.2
<b>60 Skott</b> 	21: 9.3 ← 22: 9.8 ↑ 23: 10.5x → 24: 9.3 ↓ 25: 10.1 ← 26: 9.6 ← 27: 8.6 ↘ 28: 10.2x ↗ 29: 9.5 ↓ 30: 9.7 ↗ Serie 96.6 Total 285.8	<b>60 Skott</b> 	31: 9.5 ↘ 32: 9.2 ↗ 33: 8.7 → 34: 9.0 ↗ 35: 9.7 ↗ 36: 10.6x ↓ 37: 9.9 ↓ 38: 9.6 ↗ 39: 10.8x ↓ 40: 10.3x ← Serie 97.3 Total 383.1
<b>60 Skott</b> 	41: 9.1 ↗ 42: 9.6 ↗ 43: 10.1 → 44: 10.1 ↑ 45: 7.9 ↓ 46: 10.3x ← 47: 9.1 ↓ 48: 8.2 ↘ 49: 9.8 ↓ 50: 10.3x ↗ Serie 94.5 Total 477.6	<b>60 Skott</b> 	51: 10.4x ↓ 52: 6.7 → 53: 8.9 ↘ 54: 9.7 ↗ 55: 9.7 → 56: 8.0 ↗ 57: 9.0 → 58: 9.8 ↓ 59: 9.8 ↑ 60: 10.8x ↓ Serie 92.8 Total 570.4

<b>Pröv</b> 	1: 10.3x → 2: 9.8 ↓ 3: 9.6 → 4: 7.6 ← 5: 9.7 ↗ 6: 8.4 ↗ 7: 10.2x → 8: 8.8 → 9: 9.0 ↓ 10: 9.9 ↓ <hr/> Serie 93.3 Total 0.0	<b>Pröv</b> 	11: 10.6x ↑ 12: 8.7 ← 13: 10.4x ← 14: 10.9x ↓ <hr/> Serie 40.6 Total 0.0
<b>60 Skott</b> 	1: 10.5x ← 2: 10.1 ↗ 3: 10.4x ↗ 4: 10.1 ↑ 5: 8.9 ← 6: 8.8 ↗ 7: 9.7 ← 8: 9.9 ↓ 9: 9.8 ↗ 10: 10.1 ↗ <hr/> Serie 98.3 Total 98.3	<b>60 Skott</b> 	11: 10.4x → 12: 10.7x ← 13: 9.7 ↗ 14: 9.8 ↗ 15: 10.3x ← 16: 9.3 ← 17: 10.3x ↑ 18: 9.3 ← 19: 9.6 ← 20: 10.7x ← <hr/> Serie 100.1 Total 198.4
<b>60 Skott</b> 	21: 9.4 ← 22: 9.6 → 23: 9.5 ↗ 24: 10.4x ↑ 25: 10.5x ↗ 26: 9.5 ↓ 27: 9.8 ← 28: 10.0 ← 29: 10.6x ↓ 30: 10.4x ↗ <hr/> Serie 99.7 Total 298.1	<b>60 Skott</b> 	31: 9.7 ← 32: 10.4x ↑ 33: 10.1 ↑ 34: 10.2x ↓ 35: 10.0 ← 36: 10.8x ↑ 37: 10.1 ↓ 38: 9.9 → 39: 10.4x ↑ 40: 9.1 ↓ <hr/> Serie 100.7 Total 398.8
<b>60 Skott</b> 	41: 10.4x ← 42: 10.2x ↑ 43: 10.2x ↓ 44: 10.6x ↑ 45: 7.3 ← 46: 10.0 ← 47: 10.1 ↓ 48: 10.0 ↗ 49: 10.6x ← 50: 10.3x ← <hr/> Serie 99.7 Total 498.5	<b>60 Skott</b> 	51: 10.5x ↓ 52: 9.6 ↓ 53: 10.4x ↑ 54: 10.4x ← 55: 10.0 → 56: 10.6x ↓ 57: 10.8x → 58: 9.9 ↓ 59: 10.5x ↓ 60: 10.4x → <hr/> Serie 103.1 Total 601.6

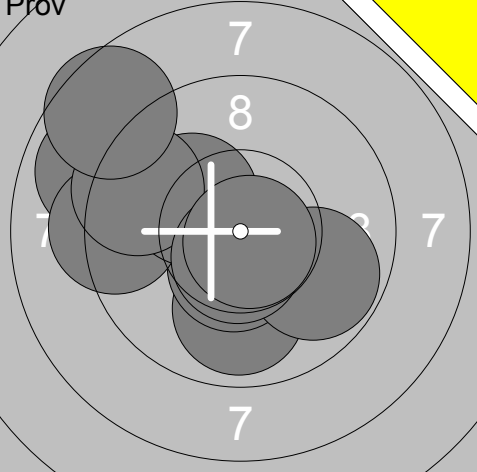
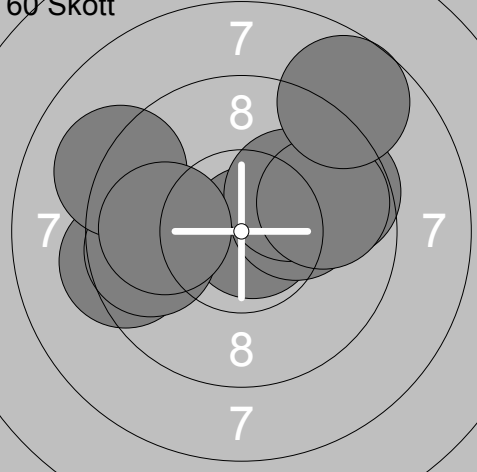
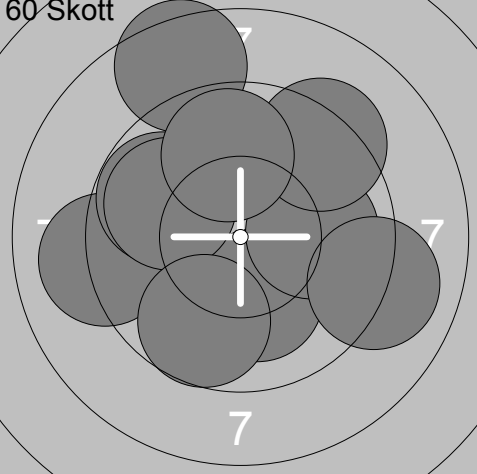
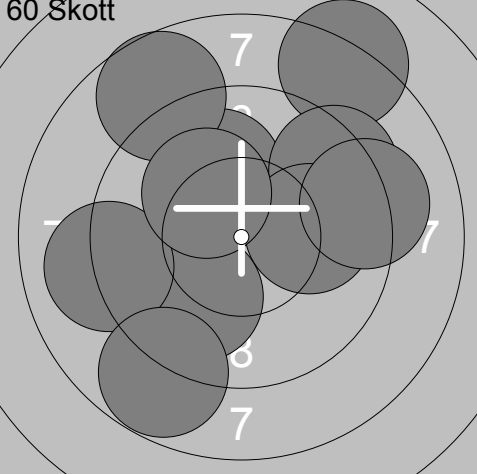
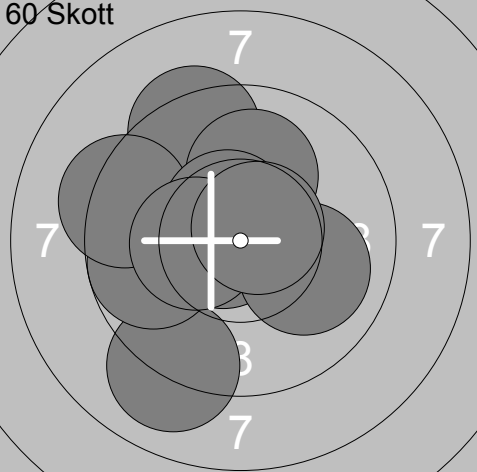
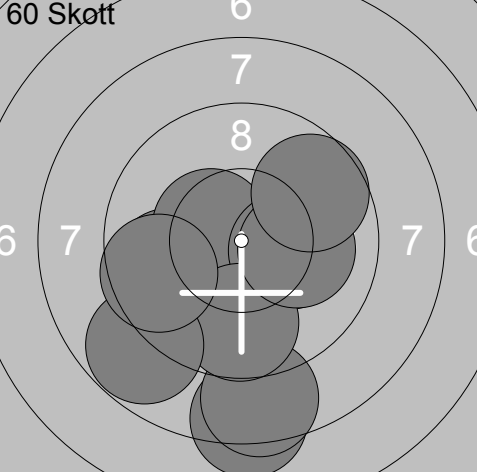
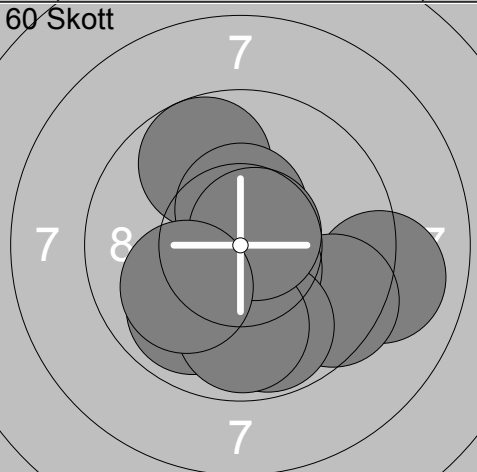
<p>Pröv</p> 	<table border="1" style="width:100%; border-collapse: collapse;"> <tr><td>1:</td><td>9.9</td><td>↓</td></tr> <tr><td>2:</td><td>10.5x</td><td>↓</td></tr> <tr><td>3:</td><td>9.8</td><td>↘</td></tr> <tr><td>4:</td><td>8.9</td><td>↗</td></tr> <tr><td>5:</td><td>9.3</td><td>←</td></tr> <tr><td>6:</td><td>10.2x</td><td>↗</td></tr> <tr><td>7:</td><td>9.4</td><td>↗</td></tr> <tr><td>8:</td><td>8.6</td><td>↗</td></tr> <tr><td>9:</td><td>10.6x</td><td>↓</td></tr> <tr><td>10:</td><td>10.8x</td><td>↘</td></tr> <tr><td colspan="2">Serie</td><td>98.0</td></tr> <tr><td colspan="2">Total</td><td>0.0</td></tr> </table>	1:	9.9	↓	2:	10.5x	↓	3:	9.8	↘	4:	8.9	↗	5:	9.3	←	6:	10.2x	↗	7:	9.4	↗	8:	8.6	↗	9:	10.6x	↓	10:	10.8x	↘	Serie		98.0	Total		0.0	<p>60 Skott</p>  <table border="1" style="width:100%; border-collapse: collapse;"> <tr><td>1:</td><td>9.3</td><td>←</td></tr> <tr><td>2:</td><td>10.8x</td><td>→</td></tr> <tr><td>3:</td><td>9.6</td><td>→</td></tr> <tr><td>4:</td><td>10.2x</td><td>→</td></tr> <tr><td>5:</td><td>10.1</td><td>↗</td></tr> <tr><td>6:</td><td>9.8</td><td>→</td></tr> <tr><td>7:</td><td>9.7</td><td>←</td></tr> <tr><td>8:</td><td>9.1</td><td>↖</td></tr> <tr><td>9:</td><td>8.7</td><td>↗</td></tr> <tr><td>10:</td><td>9.9</td><td>←</td></tr> <tr><td colspan="2">Serie</td><td>97.2</td></tr> <tr><td colspan="2">Total</td><td>97.2</td></tr> </table>	1:	9.3	←	2:	10.8x	→	3:	9.6	→	4:	10.2x	→	5:	10.1	↗	6:	9.8	→	7:	9.7	←	8:	9.1	↖	9:	8.7	↗	10:	9.9	←	Serie		97.2	Total		97.2
1:	9.9	↓																																																																								
2:	10.5x	↓																																																																								
3:	9.8	↘																																																																								
4:	8.9	↗																																																																								
5:	9.3	←																																																																								
6:	10.2x	↗																																																																								
7:	9.4	↗																																																																								
8:	8.6	↗																																																																								
9:	10.6x	↓																																																																								
10:	10.8x	↘																																																																								
Serie		98.0																																																																								
Total		0.0																																																																								
1:	9.3	←																																																																								
2:	10.8x	→																																																																								
3:	9.6	→																																																																								
4:	10.2x	→																																																																								
5:	10.1	↗																																																																								
6:	9.8	→																																																																								
7:	9.7	←																																																																								
8:	9.1	↖																																																																								
9:	8.7	↗																																																																								
10:	9.9	←																																																																								
Serie		97.2																																																																								
Total		97.2																																																																								
<p>60 Skott</p> 	<table border="1" style="width:100%; border-collapse: collapse;"> <tr><td>11:</td><td>8.5</td><td>↗</td></tr> <tr><td>12:</td><td>9.1</td><td>←</td></tr> <tr><td>13:</td><td>9.8</td><td>↗</td></tr> <tr><td>14:</td><td>10.1</td><td>↓</td></tr> <tr><td>15:</td><td>9.9</td><td>↗</td></tr> <tr><td>16:</td><td>9.7</td><td>↓</td></tr> <tr><td>17:</td><td>10.0</td><td>→</td></tr> <tr><td>18:</td><td>9.0</td><td>↘</td></tr> <tr><td>19:</td><td>9.3</td><td>↗</td></tr> <tr><td>20:</td><td>9.8</td><td>↑</td></tr> <tr><td colspan="2">Serie</td><td>95.2</td></tr> <tr><td colspan="2">Total</td><td>192.4</td></tr> </table>	11:	8.5	↗	12:	9.1	←	13:	9.8	↗	14:	10.1	↓	15:	9.9	↗	16:	9.7	↓	17:	10.0	→	18:	9.0	↘	19:	9.3	↗	20:	9.8	↑	Serie		95.2	Total		192.4	<p>60 Skott</p>  <table border="1" style="width:100%; border-collapse: collapse;"> <tr><td>21:</td><td>9.9</td><td>↓</td></tr> <tr><td>22:</td><td>8.2</td><td>↗</td></tr> <tr><td>23:</td><td>9.1</td><td>←</td></tr> <tr><td>24:</td><td>10.0</td><td>↑</td></tr> <tr><td>25:</td><td>9.4</td><td>↗</td></tr> <tr><td>26:</td><td>8.7</td><td>↗</td></tr> <tr><td>27:</td><td>10.0</td><td>→</td></tr> <tr><td>28:</td><td>10.2x</td><td>↗</td></tr> <tr><td>29:</td><td>9.2</td><td>→</td></tr> <tr><td>30:</td><td>8.8</td><td>↓</td></tr> <tr><td colspan="2">Serie</td><td>93.5</td></tr> <tr><td colspan="2">Total</td><td>285.9</td></tr> </table>	21:	9.9	↓	22:	8.2	↗	23:	9.1	←	24:	10.0	↑	25:	9.4	↗	26:	8.7	↗	27:	10.0	→	28:	10.2x	↗	29:	9.2	→	30:	8.8	↓	Serie		93.5	Total		285.9
11:	8.5	↗																																																																								
12:	9.1	←																																																																								
13:	9.8	↗																																																																								
14:	10.1	↓																																																																								
15:	9.9	↗																																																																								
16:	9.7	↓																																																																								
17:	10.0	→																																																																								
18:	9.0	↘																																																																								
19:	9.3	↗																																																																								
20:	9.8	↑																																																																								
Serie		95.2																																																																								
Total		192.4																																																																								
21:	9.9	↓																																																																								
22:	8.2	↗																																																																								
23:	9.1	←																																																																								
24:	10.0	↑																																																																								
25:	9.4	↗																																																																								
26:	8.7	↗																																																																								
27:	10.0	→																																																																								
28:	10.2x	↗																																																																								
29:	9.2	→																																																																								
30:	8.8	↓																																																																								
Serie		93.5																																																																								
Total		285.9																																																																								
<p>60 Skott</p> 	<table border="1" style="width:100%; border-collapse: collapse;"> <tr><td>31:</td><td>9.4</td><td>↗</td></tr> <tr><td>32:</td><td>10.1</td><td>↑</td></tr> <tr><td>33:</td><td>9.0</td><td>↓</td></tr> <tr><td>34:</td><td>10.7x</td><td>←</td></tr> <tr><td>35:</td><td>9.7</td><td>←</td></tr> <tr><td>36:</td><td>10.0</td><td>↘</td></tr> <tr><td>37:</td><td>9.3</td><td>↗</td></tr> <tr><td>38:</td><td>10.6x</td><td>↗</td></tr> <tr><td>39:</td><td>10.4x</td><td>←</td></tr> <tr><td>40:</td><td>10.7x</td><td>↗</td></tr> <tr><td colspan="2">Serie</td><td>99.9</td></tr> <tr><td colspan="2">Total</td><td>385.8</td></tr> </table>	31:	9.4	↗	32:	10.1	↑	33:	9.0	↓	34:	10.7x	←	35:	9.7	←	36:	10.0	↘	37:	9.3	↗	38:	10.6x	↗	39:	10.4x	←	40:	10.7x	↗	Serie		99.9	Total		385.8	<p>60 Skott</p>  <table border="1" style="width:100%; border-collapse: collapse;"> <tr><td>41:</td><td>8.2</td><td>↓</td></tr> <tr><td>42:</td><td>9.8</td><td>←</td></tr> <tr><td>43:</td><td>10.4x</td><td>↖</td></tr> <tr><td>44:</td><td>8.5</td><td>↓</td></tr> <tr><td>45:</td><td>10.2x</td><td>→</td></tr> <tr><td>46:</td><td>9.7</td><td>↓</td></tr> <tr><td>47:</td><td>8.8</td><td>↖</td></tr> <tr><td>48:</td><td>10.1</td><td>→</td></tr> <tr><td>49:</td><td>9.6</td><td>←</td></tr> <tr><td>50:</td><td>9.7</td><td>↗</td></tr> <tr><td colspan="2">Serie</td><td>95.0</td></tr> <tr><td colspan="2">Total</td><td>480.8</td></tr> </table>	41:	8.2	↓	42:	9.8	←	43:	10.4x	↖	44:	8.5	↓	45:	10.2x	→	46:	9.7	↓	47:	8.8	↖	48:	10.1	→	49:	9.6	←	50:	9.7	↗	Serie		95.0	Total		480.8
31:	9.4	↗																																																																								
32:	10.1	↑																																																																								
33:	9.0	↓																																																																								
34:	10.7x	←																																																																								
35:	9.7	←																																																																								
36:	10.0	↘																																																																								
37:	9.3	↗																																																																								
38:	10.6x	↗																																																																								
39:	10.4x	←																																																																								
40:	10.7x	↗																																																																								
Serie		99.9																																																																								
Total		385.8																																																																								
41:	8.2	↓																																																																								
42:	9.8	←																																																																								
43:	10.4x	↖																																																																								
44:	8.5	↓																																																																								
45:	10.2x	→																																																																								
46:	9.7	↓																																																																								
47:	8.8	↖																																																																								
48:	10.1	→																																																																								
49:	9.6	←																																																																								
50:	9.7	↗																																																																								
Serie		95.0																																																																								
Total		480.8																																																																								
<p>60 Skott</p> 	<table border="1" style="width:100%; border-collapse: collapse;"> <tr><td>51:</td><td>9.9</td><td>↖</td></tr> <tr><td>52:</td><td>9.0</td><td>→</td></tr> <tr><td>53:</td><td>9.7</td><td>↗</td></tr> <tr><td>54:</td><td>9.5</td><td>↘</td></tr> <tr><td>55:</td><td>10.6x</td><td>↘</td></tr> <tr><td>56:</td><td>9.8</td><td>↓</td></tr> <tr><td>57:</td><td>10.5x</td><td>↑</td></tr> <tr><td>58:</td><td>9.9</td><td>↓</td></tr> <tr><td>59:</td><td>10.7x</td><td>↗</td></tr> <tr><td>60:</td><td>10.0</td><td>↖</td></tr> <tr><td colspan="2">Serie</td><td>99.6</td></tr> <tr><td colspan="2">Total</td><td>580.4</td></tr> </table>	51:	9.9	↖	52:	9.0	→	53:	9.7	↗	54:	9.5	↘	55:	10.6x	↘	56:	9.8	↓	57:	10.5x	↑	58:	9.9	↓	59:	10.7x	↗	60:	10.0	↖	Serie		99.6	Total		580.4																																					
51:	9.9	↖																																																																								
52:	9.0	→																																																																								
53:	9.7	↗																																																																								
54:	9.5	↘																																																																								
55:	10.6x	↘																																																																								
56:	9.8	↓																																																																								
57:	10.5x	↑																																																																								
58:	9.9	↓																																																																								
59:	10.7x	↗																																																																								
60:	10.0	↖																																																																								
Serie		99.6																																																																								
Total		580.4																																																																								

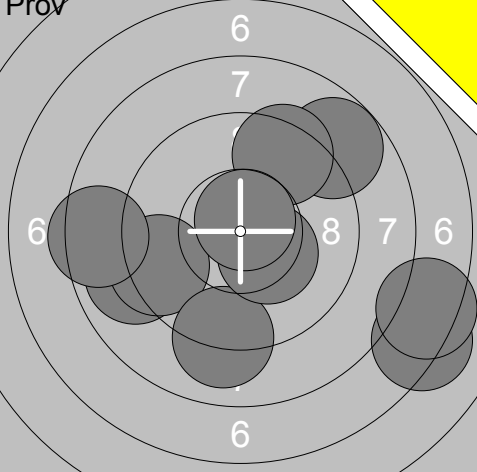
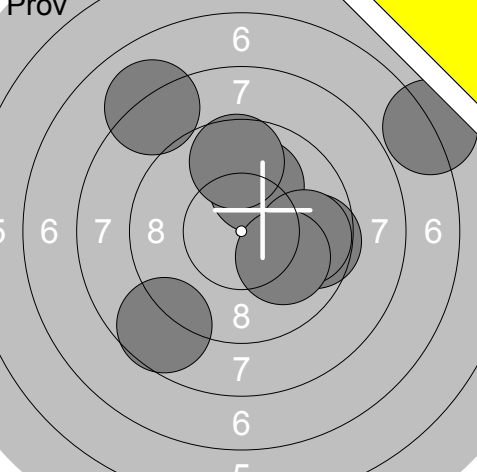
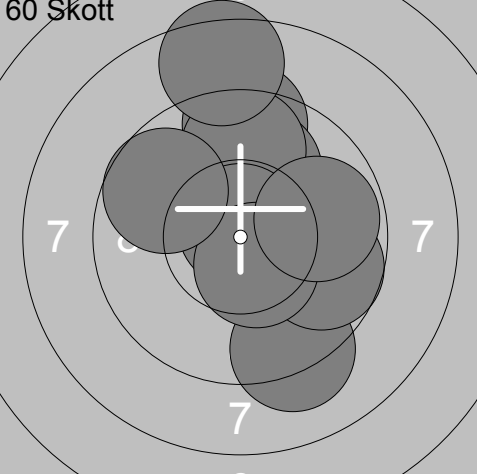
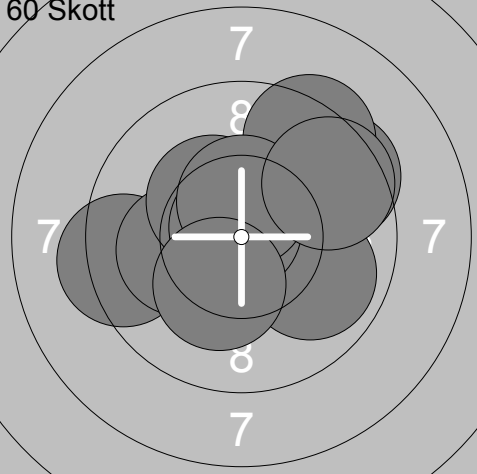
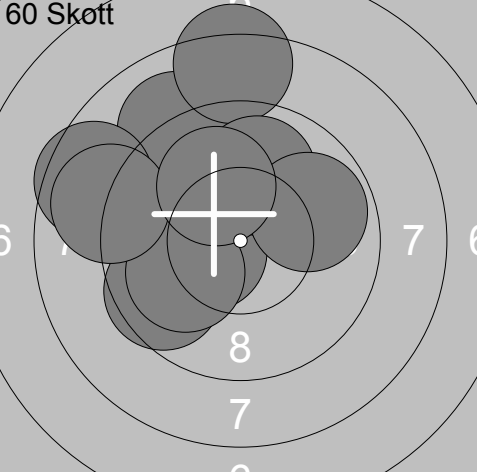
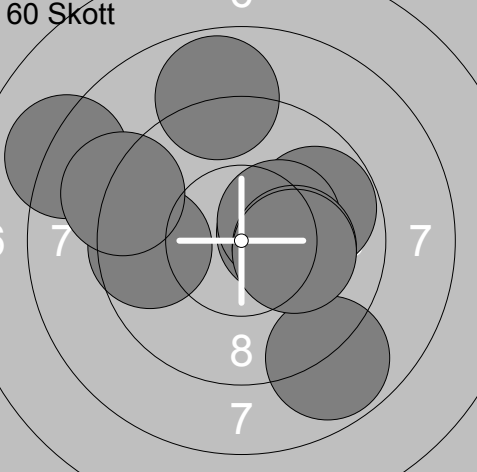
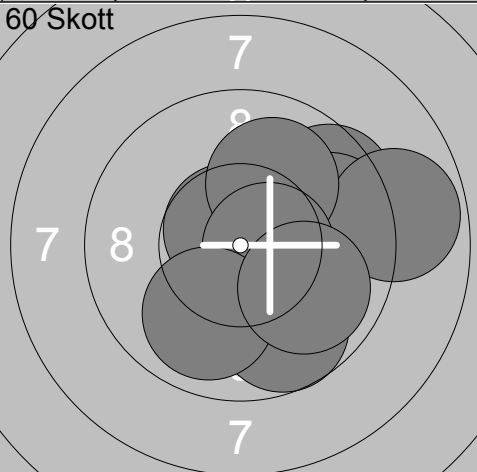
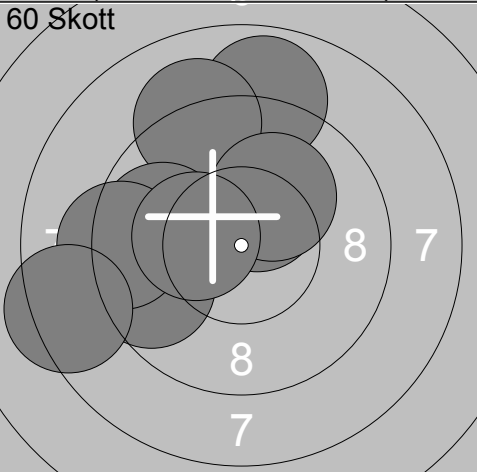
Prov 	1: 9.0 ← 2: 9.4 ← 3: 9.0 ↓ 4: 7.2 ↘ 5: 10.3x ↘ 6: 7.4 → 7: 8.8 ↗ 8: 9.4 ↗ 9: 8.4 ← 10: 10.7x ↗ <hr/> Serie 89.6 Total 0.0	Prov 	11: 6.9 → 12: 8.7 ↘ 13: 10.0 ↗ 14: 9.6 → 15: 9.6 ↗ 16: 8.1 ↗ 17: 9.8 → 18: 10.0 ↘ <hr/> Serie 72.7 Total 0.0
60 Skott 	1: 9.3 ↗ 2: 10.0 ↗ 3: 9.2 ↘ 4: 9.7 → 5: 9.7 ↗ 6: 10.8x ↗ 7: 8.5 ↗ 8: 10.5x ↘ 9: 9.8 → 10: 9.7 ↗ <hr/> Serie 97.2 Total 97.2	60 Skott 	11: 9.3 ← 12: 9.5 ↗ 13: 10.1 ← 14: 9.9 ↘ 15: 10.3x ↗ 16: 9.4 ↗ 17: 10.8x ↗ 18: 10.5x ↗ 19: 9.6 ↗ 20: 10.3x ↘ <hr/> Serie 99.7 Total 196.9
60 Skott 	21: 9.0 ↗ 22: 10.4x ← 23: 9.6 ← 24: 8.3 ↗ 25: 9.9 ↗ 26: 8.6 ← 27: 10.0 ← 28: 8.9 ← 29: 9.8 → 30: 10.1 ↗ <hr/> Serie 94.6 Total 291.5	60 Skott 	31: 9.8 ↗ 32: 8.1 ↘ 33: 9.6 ← 34: 10.4x → 35: 10.3x ↗ 36: 8.8 ↗ 37: 9.1 ← 38: 8.8 ↘ 39: 10.2x → 40: 10.2x → <hr/> Serie 95.3 Total 386.8
60 Skott 	41: 10.7x ↗ 42: 9.7 ↘ 43: 9.5 → 44: 9.7 → 45: 8.8 → 46: 10.4x ↘ 47: 10.0 ↗ 48: 10.6x → 49: 9.9 ↘ 50: 9.9 ↘ <hr/> Serie 99.2 Total 486.0	60 Skott 	51: 10.3x ↗ 52: 9.6 ← 53: 10.4x ↗ 54: 8.9 ↗ 55: 9.1 ↗ 56: 10.1 ↗ 57: 9.8 ← 58: 9.3 ← 59: 10.3x ← 60: 8.4 ← <hr/> Serie 96.2 Total 582.2

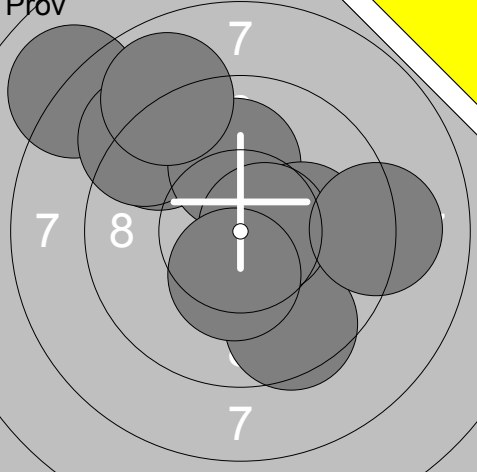
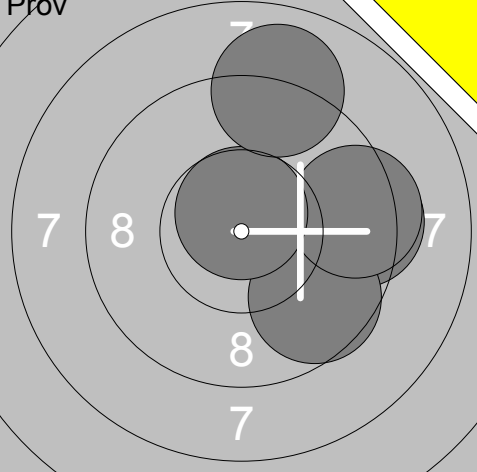
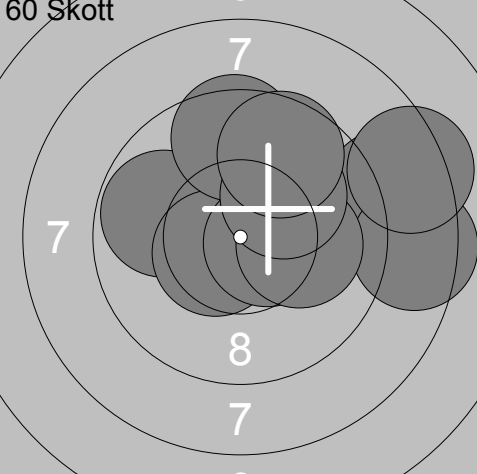
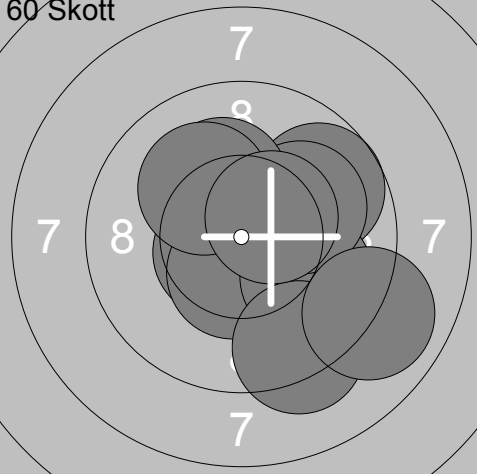
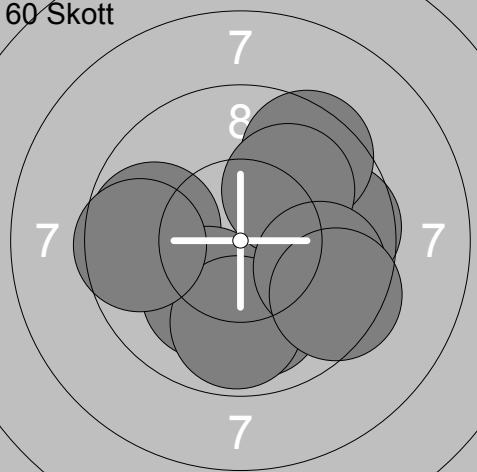
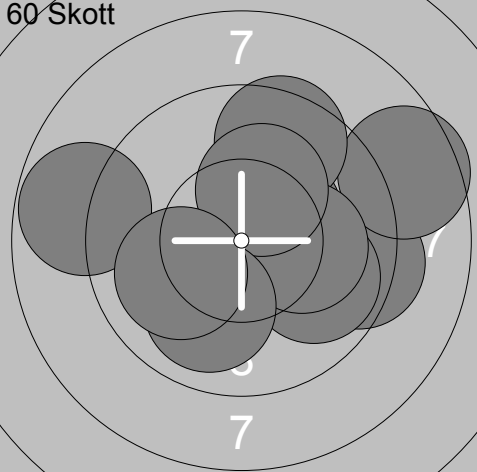
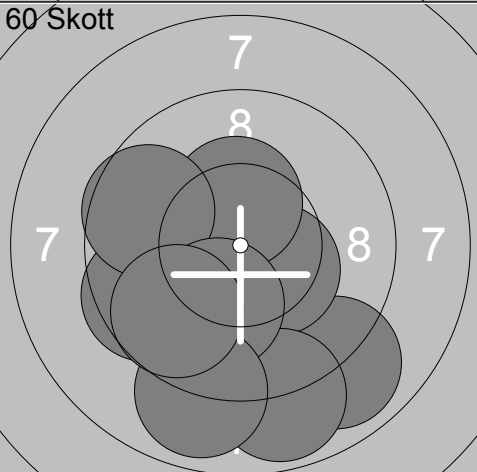
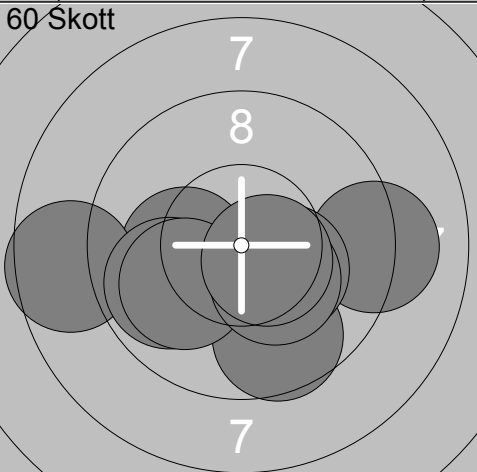
<b>Pröv</b> 	<table border="1" style="width:100%; border-collapse: collapse;"> <tr><td>1:</td><td>8.0</td><td>↗</td></tr> <tr><td>2:</td><td>9.3</td><td>↗</td></tr> <tr><td>3:</td><td>9.2</td><td>↗</td></tr> <tr><td>4:</td><td>10.1</td><td>↑</td></tr> <tr><td>5:</td><td>10.1</td><td>→</td></tr> <tr><td>6:</td><td>9.5</td><td>↘</td></tr> <tr><td>7:</td><td>10.6x</td><td>→</td></tr> <tr><td>8:</td><td>9.1</td><td>→</td></tr> <tr><td>9:</td><td>8.9</td><td>↗</td></tr> <tr><td>10:</td><td>10.4x</td><td>↘</td></tr> <tr><td colspan="2"><b>Serie</b></td><td><b>95.2</b></td></tr> <tr><td colspan="2"><b>Total</b></td><td><b>0.0</b></td></tr> </table>	1:	8.0	↗	2:	9.3	↗	3:	9.2	↗	4:	10.1	↑	5:	10.1	→	6:	9.5	↘	7:	10.6x	→	8:	9.1	→	9:	8.9	↗	10:	10.4x	↘	<b>Serie</b>		<b>95.2</b>	<b>Total</b>		<b>0.0</b>	<b>Pröv</b> 	<table border="1" style="width:100%; border-collapse: collapse;"> <tr><td>11:</td><td>9.4</td><td>→</td></tr> <tr><td>12:</td><td>9.6</td><td>↘</td></tr> <tr><td>13:</td><td>9.4</td><td>→</td></tr> <tr><td>14:</td><td>10.7x</td><td>↑</td></tr> <tr><td>15:</td><td>9.0</td><td>↑</td></tr> <tr><td colspan="2"><b>Serie</b></td><td><b>48.1</b></td></tr> <tr><td colspan="2"><b>Total</b></td><td><b>0.0</b></td></tr> </table>	11:	9.4	→	12:	9.6	↘	13:	9.4	→	14:	10.7x	↑	15:	9.0	↑	<b>Serie</b>		<b>48.1</b>	<b>Total</b>		<b>0.0</b>															
1:	8.0	↗																																																																									
2:	9.3	↗																																																																									
3:	9.2	↗																																																																									
4:	10.1	↑																																																																									
5:	10.1	→																																																																									
6:	9.5	↘																																																																									
7:	10.6x	→																																																																									
8:	9.1	→																																																																									
9:	8.9	↗																																																																									
10:	10.4x	↘																																																																									
<b>Serie</b>		<b>95.2</b>																																																																									
<b>Total</b>		<b>0.0</b>																																																																									
11:	9.4	→																																																																									
12:	9.6	↘																																																																									
13:	9.4	→																																																																									
14:	10.7x	↑																																																																									
15:	9.0	↑																																																																									
<b>Serie</b>		<b>48.1</b>																																																																									
<b>Total</b>		<b>0.0</b>																																																																									
<b>60 Skott</b> 	<table border="1" style="width:100%; border-collapse: collapse;"> <tr><td>1:</td><td>9.8</td><td>←</td></tr> <tr><td>2:</td><td>8.8</td><td>→</td></tr> <tr><td>3:</td><td>10.5x</td><td>←</td></tr> <tr><td>4:</td><td>9.5</td><td>↑</td></tr> <tr><td>5:</td><td>8.5</td><td>→</td></tr> <tr><td>6:</td><td>10.6x</td><td>→</td></tr> <tr><td>7:</td><td>10.1</td><td>→</td></tr> <tr><td>8:</td><td>10.1</td><td>↗</td></tr> <tr><td>9:</td><td>9.6</td><td>↗</td></tr> <tr><td>10:</td><td>8.3</td><td>→</td></tr> <tr><td colspan="2"><b>Serie</b></td><td><b>95.8</b></td></tr> <tr><td colspan="2"><b>Total</b></td><td><b>95.8</b></td></tr> </table>	1:	9.8	←	2:	8.8	→	3:	10.5x	←	4:	9.5	↑	5:	8.5	→	6:	10.6x	→	7:	10.1	→	8:	10.1	↗	9:	9.6	↗	10:	8.3	→	<b>Serie</b>		<b>95.8</b>	<b>Total</b>		<b>95.8</b>	<b>60 Skott</b> 	<table border="1" style="width:100%; border-collapse: collapse;"> <tr><td>11:</td><td>10.6x</td><td>←</td></tr> <tr><td>12:</td><td>10.5x</td><td>↘</td></tr> <tr><td>13:</td><td>9.7</td><td>↗</td></tr> <tr><td>14:</td><td>9.9</td><td>↘</td></tr> <tr><td>15:</td><td>10.1</td><td>↗</td></tr> <tr><td>16:</td><td>9.3</td><td>↘</td></tr> <tr><td>17:</td><td>10.2x</td><td>↗</td></tr> <tr><td>18:</td><td>8.9</td><td>↘</td></tr> <tr><td>19:</td><td>10.1</td><td>↗</td></tr> <tr><td>20:</td><td>10.5x</td><td>↗</td></tr> <tr><td colspan="2"><b>Serie</b></td><td><b>99.8</b></td></tr> <tr><td colspan="2"><b>Total</b></td><td><b>195.6</b></td></tr> </table>	11:	10.6x	←	12:	10.5x	↘	13:	9.7	↗	14:	9.9	↘	15:	10.1	↗	16:	9.3	↘	17:	10.2x	↗	18:	8.9	↘	19:	10.1	↗	20:	10.5x	↗	<b>Serie</b>		<b>99.8</b>	<b>Total</b>		<b>195.6</b>
1:	9.8	←																																																																									
2:	8.8	→																																																																									
3:	10.5x	←																																																																									
4:	9.5	↑																																																																									
5:	8.5	→																																																																									
6:	10.6x	→																																																																									
7:	10.1	→																																																																									
8:	10.1	↗																																																																									
9:	9.6	↗																																																																									
10:	8.3	→																																																																									
<b>Serie</b>		<b>95.8</b>																																																																									
<b>Total</b>		<b>95.8</b>																																																																									
11:	10.6x	←																																																																									
12:	10.5x	↘																																																																									
13:	9.7	↗																																																																									
14:	9.9	↘																																																																									
15:	10.1	↗																																																																									
16:	9.3	↘																																																																									
17:	10.2x	↗																																																																									
18:	8.9	↘																																																																									
19:	10.1	↗																																																																									
20:	10.5x	↗																																																																									
<b>Serie</b>		<b>99.8</b>																																																																									
<b>Total</b>		<b>195.6</b>																																																																									
<b>60 Skott</b> 	<table border="1" style="width:100%; border-collapse: collapse;"> <tr><td>21:</td><td>10.0</td><td>↘</td></tr> <tr><td>22:</td><td>9.8</td><td>←</td></tr> <tr><td>23:</td><td>10.1</td><td>↘</td></tr> <tr><td>24:</td><td>9.7</td><td>→</td></tr> <tr><td>25:</td><td>9.5</td><td>↗</td></tr> <tr><td>26:</td><td>10.0</td><td>↗</td></tr> <tr><td>27:</td><td>9.8</td><td>↘</td></tr> <tr><td>28:</td><td>9.8</td><td>→</td></tr> <tr><td>29:</td><td>9.6</td><td>←</td></tr> <tr><td>30:</td><td>9.5</td><td>↘</td></tr> <tr><td colspan="2"><b>Serie</b></td><td><b>97.8</b></td></tr> <tr><td colspan="2"><b>Total</b></td><td><b>293.4</b></td></tr> </table>	21:	10.0	↘	22:	9.8	←	23:	10.1	↘	24:	9.7	→	25:	9.5	↗	26:	10.0	↗	27:	9.8	↘	28:	9.8	→	29:	9.6	←	30:	9.5	↘	<b>Serie</b>		<b>97.8</b>	<b>Total</b>		<b>293.4</b>	<b>60 Skott</b> 	<table border="1" style="width:100%; border-collapse: collapse;"> <tr><td>31:</td><td>8.8</td><td>←</td></tr> <tr><td>32:</td><td>9.3</td><td>→</td></tr> <tr><td>33:</td><td>8.6</td><td>↗</td></tr> <tr><td>34:</td><td>9.9</td><td>↘</td></tr> <tr><td>35:</td><td>10.4x</td><td>↗</td></tr> <tr><td>36:</td><td>9.5</td><td>↑</td></tr> <tr><td>37:</td><td>10.1</td><td>→</td></tr> <tr><td>38:</td><td>10.2x</td><td>↗</td></tr> <tr><td>39:</td><td>10.0</td><td>↘</td></tr> <tr><td>40:</td><td>10.0</td><td>←</td></tr> <tr><td colspan="2"><b>Serie</b></td><td><b>96.8</b></td></tr> <tr><td colspan="2"><b>Total</b></td><td><b>390.2</b></td></tr> </table>	31:	8.8	←	32:	9.3	→	33:	8.6	↗	34:	9.9	↘	35:	10.4x	↗	36:	9.5	↑	37:	10.1	→	38:	10.2x	↗	39:	10.0	↘	40:	10.0	←	<b>Serie</b>		<b>96.8</b>	<b>Total</b>		<b>390.2</b>
21:	10.0	↘																																																																									
22:	9.8	←																																																																									
23:	10.1	↘																																																																									
24:	9.7	→																																																																									
25:	9.5	↗																																																																									
26:	10.0	↗																																																																									
27:	9.8	↘																																																																									
28:	9.8	→																																																																									
29:	9.6	←																																																																									
30:	9.5	↘																																																																									
<b>Serie</b>		<b>97.8</b>																																																																									
<b>Total</b>		<b>293.4</b>																																																																									
31:	8.8	←																																																																									
32:	9.3	→																																																																									
33:	8.6	↗																																																																									
34:	9.9	↘																																																																									
35:	10.4x	↗																																																																									
36:	9.5	↑																																																																									
37:	10.1	→																																																																									
38:	10.2x	↗																																																																									
39:	10.0	↘																																																																									
40:	10.0	←																																																																									
<b>Serie</b>		<b>96.8</b>																																																																									
<b>Total</b>		<b>390.2</b>																																																																									
<b>60 Skott</b> 	<table border="1" style="width:100%; border-collapse: collapse;"> <tr><td>41:</td><td>8.9</td><td>↘</td></tr> <tr><td>42:</td><td>10.3x</td><td>↘</td></tr> <tr><td>43:</td><td>9.5</td><td>←</td></tr> <tr><td>44:</td><td>10.4x</td><td>↘</td></tr> <tr><td>45:</td><td>8.9</td><td>↘</td></tr> <tr><td>46:</td><td>10.4x</td><td>↑</td></tr> <tr><td>47:</td><td>9.6</td><td>←</td></tr> <tr><td>48:</td><td>10.1</td><td>↘</td></tr> <tr><td>49:</td><td>8.9</td><td>↘</td></tr> <tr><td>50:</td><td>9.7</td><td>↘</td></tr> <tr><td colspan="2"><b>Serie</b></td><td><b>96.7</b></td></tr> <tr><td colspan="2"><b>Total</b></td><td><b>486.9</b></td></tr> </table>	41:	8.9	↘	42:	10.3x	↘	43:	9.5	←	44:	10.4x	↘	45:	8.9	↘	46:	10.4x	↑	47:	9.6	←	48:	10.1	↘	49:	8.9	↘	50:	9.7	↘	<b>Serie</b>		<b>96.7</b>	<b>Total</b>		<b>486.9</b>	<b>60 Skott</b> 	<table border="1" style="width:100%; border-collapse: collapse;"> <tr><td>51:</td><td>10.1</td><td>←</td></tr> <tr><td>52:</td><td>10.2x</td><td>←</td></tr> <tr><td>53:</td><td>9.1</td><td>→</td></tr> <tr><td>54:</td><td>9.6</td><td>↘</td></tr> <tr><td>55:</td><td>8.6</td><td>←</td></tr> <tr><td>56:</td><td>10.3x</td><td>↘</td></tr> <tr><td>57:</td><td>9.8</td><td>←</td></tr> <tr><td>58:</td><td>10.0</td><td>←</td></tr> <tr><td>59:</td><td>10.3x</td><td>↘</td></tr> <tr><td>60:</td><td>10.5x</td><td>↘</td></tr> <tr><td colspan="2"><b>Serie</b></td><td><b>98.5</b></td></tr> <tr><td colspan="2"><b>Total</b></td><td><b>585.4</b></td></tr> </table>	51:	10.1	←	52:	10.2x	←	53:	9.1	→	54:	9.6	↘	55:	8.6	←	56:	10.3x	↘	57:	9.8	←	58:	10.0	←	59:	10.3x	↘	60:	10.5x	↘	<b>Serie</b>		<b>98.5</b>	<b>Total</b>		<b>585.4</b>
41:	8.9	↘																																																																									
42:	10.3x	↘																																																																									
43:	9.5	←																																																																									
44:	10.4x	↘																																																																									
45:	8.9	↘																																																																									
46:	10.4x	↑																																																																									
47:	9.6	←																																																																									
48:	10.1	↘																																																																									
49:	8.9	↘																																																																									
50:	9.7	↘																																																																									
<b>Serie</b>		<b>96.7</b>																																																																									
<b>Total</b>		<b>486.9</b>																																																																									
51:	10.1	←																																																																									
52:	10.2x	←																																																																									
53:	9.1	→																																																																									
54:	9.6	↘																																																																									
55:	8.6	←																																																																									
56:	10.3x	↘																																																																									
57:	9.8	←																																																																									
58:	10.0	←																																																																									
59:	10.3x	↘																																																																									
60:	10.5x	↘																																																																									
<b>Serie</b>		<b>98.5</b>																																																																									
<b>Total</b>		<b>585.4</b>																																																																									

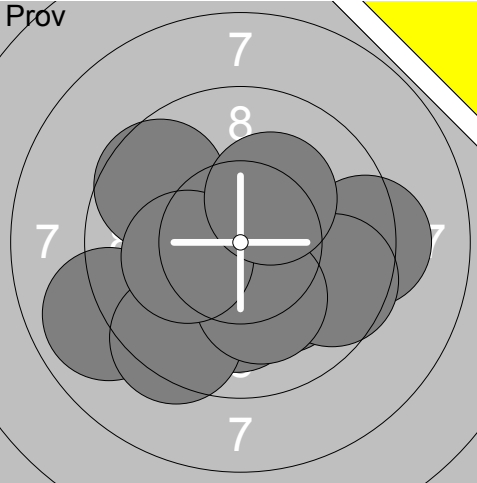
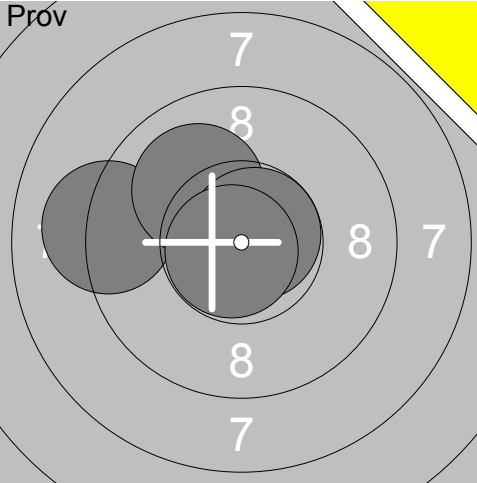
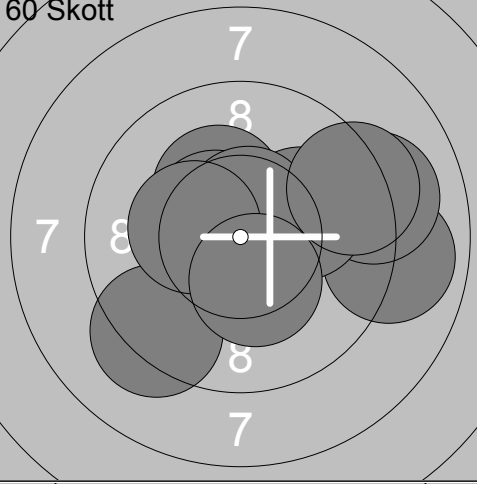
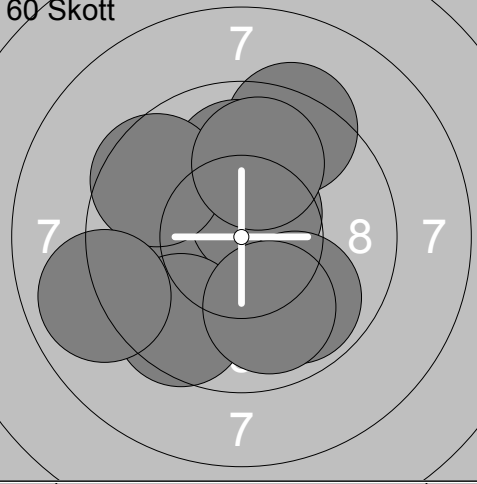
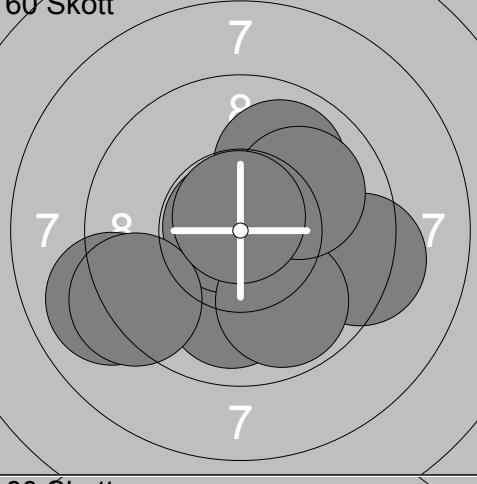
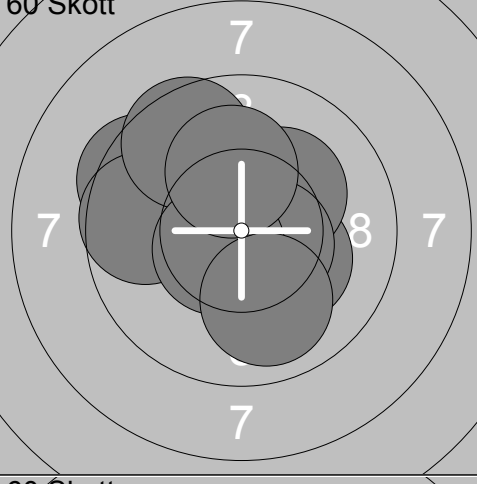
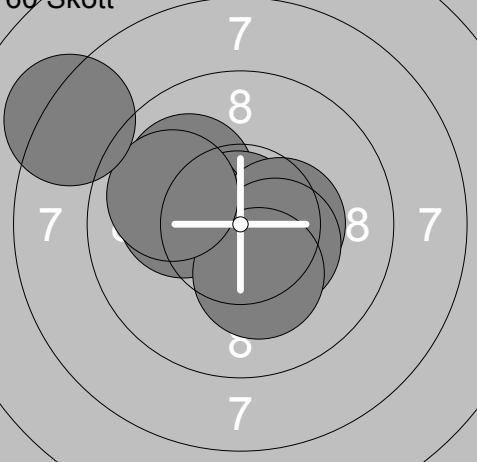
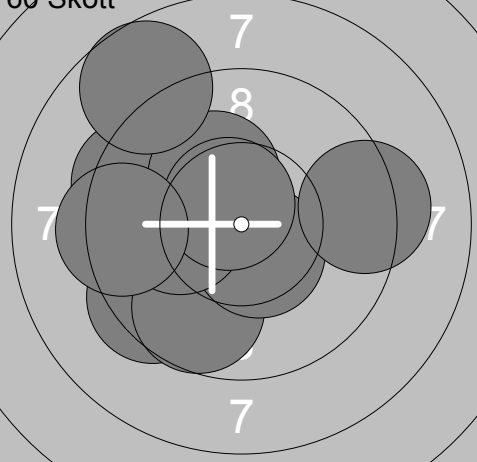
Skjutlag	Tavla	Mattias Jonsson	
3	14		
Vindeln	Forsa		Gä
18.03.2017	SM & JSM Luftgevär 2017	Ramselefors SKF	
<b>Pröv</b> 	1: 8.9 ↙ 2: 10.1 ↓ 3: 9.3 → 4: 9.4 ↓ 5: 10.1 ↓ 6: 9.6 → 7: 9.6 ↗ 8: 10.2x ↓ 9: 10.2x ← 10: 10.2x ↗ Serie 97.6 Total 0.0	<b>Pröv</b> 	11: 9.1 ← 12: 10.0 ↗ 13: 10.7x ↗ 14: 10.8x ↓ Serie 40.6 Total 0.0
<b>60 Skott</b> 	1: 8.9 → 2: 9.1 → 3: 10.3x ↗ 4: 10.5x ↗ 5: 10.1 → 6: 9.3 ↓ 7: 10.6x ↗ 8: 10.3x ← 9: 9.3 → 10: 10.3x ↓ Serie 98.7 Total 98.7	<b>60 Skott</b> 	11: 9.3 ↗ 12: 10.0 ↑ 13: 9.6 ↓ 14: 10.6x ↗ 15: 9.6 ↖ 16: 9.6 ↓ 17: 8.9 ← 18: 9.9 ↓ 19: 9.9 ↑ 20: 9.9 ↓ Serie 97.3 Total 196.0
<b>60 Skott</b> 	21: 9.9 ↗ 22: 10.0 ↓ 23: 9.0 ← 24: 10.8x ← 25: 10.4x → 26: 9.3 → 27: 9.8 ↓ 28: 9.3 ← 29: 10.0 → 30: 10.8x ↑ Serie 99.3 Total 295.3	<b>60 Skott</b> 	31: 10.2x → 32: 9.5 ↖ 33: 10.2x ↗ 34: 10.6x ← 35: 9.6 ← 36: 10.5x → 37: 9.6 ↗ 38: 10.6x ↖ 39: 10.0 ↓ 40: 10.1 ↑ Serie 100.9 Total 396.2
<b>60 Skott</b> 	41: 10.5x ↗ 42: 10.5x ↓ 43: 10.0 ↗ 44: 10.8x ↗ 45: 10.2x ← 46: 10.4x → 47: 10.4x ↓ 48: 10.2x ↓ 49: 9.9 ↗ 50: 8.2 ↗ Serie 101.1 Total 497.3	<b>60 Skott</b> 	51: 9.4 ↖ 52: 9.7 ↓ 53: 10.5x ↓ 54: 9.4 ↖ 55: 10.1 ← 56: 10.2x ↗ 57: 8.7 ↗ 58: 10.6x ↗ 59: 9.3 → 60: 9.3 ← Serie 97.2 Total 594.5

<p><b>Pröv</b></p>	<table border="1" style="width:100%; border-collapse: collapse;"> <tr><td>1:</td><td>8.6</td><td>↑</td></tr> <tr><td>2:</td><td>10.0</td><td>↖</td></tr> <tr><td>3:</td><td>9.3</td><td>→</td></tr> <tr><td>4:</td><td>10.3x</td><td>↗</td></tr> <tr><td>5:</td><td>9.7</td><td>↑</td></tr> <tr><td>6:</td><td>9.5</td><td>↑</td></tr> <tr><td>7:</td><td>10.9x</td><td>→</td></tr> <tr><td>8:</td><td>9.8</td><td>→</td></tr> <tr><td>9:</td><td>10.2x</td><td>←</td></tr> <tr><td>10:</td><td>10.2x</td><td>↖</td></tr> <tr><td colspan="2"><b>Serie</b></td><td style="text-align: right;"><b>98.5</b></td></tr> <tr><td colspan="2"><b>Total</b></td><td style="text-align: right;"><b>0.0</b></td></tr> </table>	1:	8.6	↑	2:	10.0	↖	3:	9.3	→	4:	10.3x	↗	5:	9.7	↑	6:	9.5	↑	7:	10.9x	→	8:	9.8	→	9:	10.2x	←	10:	10.2x	↖	<b>Serie</b>		<b>98.5</b>	<b>Total</b>		<b>0.0</b>	<p><b>Pröv</b></p>	<table border="1" style="width:100%; border-collapse: collapse;"> <tr><td>11:</td><td>10.3x</td><td>↓</td></tr> <tr><td>12:</td><td>9.7</td><td>↗</td></tr> <tr><td>13:</td><td>9.7</td><td>↗</td></tr> <tr><td>14:</td><td>10.6x</td><td>↘</td></tr> <tr><td>15:</td><td>10.4x</td><td>↓</td></tr> <tr><td>16:</td><td>10.2x</td><td>↑</td></tr> <tr><td>17:</td><td>9.5</td><td>→</td></tr> <tr><td colspan="2"><b>Serie</b></td><td style="text-align: right;"><b>70.4</b></td></tr> <tr><td colspan="2"><b>Total</b></td><td style="text-align: right;"><b>0.0</b></td></tr> </table>	11:	10.3x	↓	12:	9.7	↗	13:	9.7	↗	14:	10.6x	↘	15:	10.4x	↓	16:	10.2x	↑	17:	9.5	→	<b>Serie</b>		<b>70.4</b>	<b>Total</b>		<b>0.0</b>									
1:	8.6	↑																																																																									
2:	10.0	↖																																																																									
3:	9.3	→																																																																									
4:	10.3x	↗																																																																									
5:	9.7	↑																																																																									
6:	9.5	↑																																																																									
7:	10.9x	→																																																																									
8:	9.8	→																																																																									
9:	10.2x	←																																																																									
10:	10.2x	↖																																																																									
<b>Serie</b>		<b>98.5</b>																																																																									
<b>Total</b>		<b>0.0</b>																																																																									
11:	10.3x	↓																																																																									
12:	9.7	↗																																																																									
13:	9.7	↗																																																																									
14:	10.6x	↘																																																																									
15:	10.4x	↓																																																																									
16:	10.2x	↑																																																																									
17:	9.5	→																																																																									
<b>Serie</b>		<b>70.4</b>																																																																									
<b>Total</b>		<b>0.0</b>																																																																									
<p><b>60 Skott</b></p>	<table border="1" style="width:100%; border-collapse: collapse;"> <tr><td>1:</td><td>10.1</td><td>↑</td></tr> <tr><td>2:</td><td>10.0</td><td>↗</td></tr> <tr><td>3:</td><td>9.5</td><td>↗</td></tr> <tr><td>4:</td><td>10.7x</td><td>→</td></tr> <tr><td>5:</td><td>9.9</td><td>←</td></tr> <tr><td>6:</td><td>10.0</td><td>→</td></tr> <tr><td>7:</td><td>10.0</td><td>↗</td></tr> <tr><td>8:</td><td>9.9</td><td>↗</td></tr> <tr><td>9:</td><td>9.8</td><td>↑</td></tr> <tr><td>10:</td><td>10.4x</td><td>↑</td></tr> <tr><td colspan="2"><b>Serie</b></td><td style="text-align: right;"><b>100.3</b></td></tr> <tr><td colspan="2"><b>Total</b></td><td style="text-align: right;"><b>100.3</b></td></tr> </table>	1:	10.1	↑	2:	10.0	↗	3:	9.5	↗	4:	10.7x	→	5:	9.9	←	6:	10.0	→	7:	10.0	↗	8:	9.9	↗	9:	9.8	↑	10:	10.4x	↑	<b>Serie</b>		<b>100.3</b>	<b>Total</b>		<b>100.3</b>	<p><b>60 Skott</b></p>	<table border="1" style="width:100%; border-collapse: collapse;"> <tr><td>11:</td><td>10.2x</td><td>→</td></tr> <tr><td>12:</td><td>10.1</td><td>→</td></tr> <tr><td>13:</td><td>10.6x</td><td>↖</td></tr> <tr><td>14:</td><td>10.6x</td><td>↓</td></tr> <tr><td>15:</td><td>10.2x</td><td>→</td></tr> <tr><td>16:</td><td>9.3</td><td>↗</td></tr> <tr><td>17:</td><td>10.6x</td><td>→</td></tr> <tr><td>18:</td><td>10.3x</td><td>↓</td></tr> <tr><td>19:</td><td>10.2x</td><td>→</td></tr> <tr><td>20:</td><td>9.1</td><td>→</td></tr> <tr><td colspan="2"><b>Serie</b></td><td style="text-align: right;"><b>101.2</b></td></tr> <tr><td colspan="2"><b>Total</b></td><td style="text-align: right;"><b>201.5</b></td></tr> </table>	11:	10.2x	→	12:	10.1	→	13:	10.6x	↖	14:	10.6x	↓	15:	10.2x	→	16:	9.3	↗	17:	10.6x	→	18:	10.3x	↓	19:	10.2x	→	20:	9.1	→	<b>Serie</b>		<b>101.2</b>	<b>Total</b>		<b>201.5</b>
1:	10.1	↑																																																																									
2:	10.0	↗																																																																									
3:	9.5	↗																																																																									
4:	10.7x	→																																																																									
5:	9.9	←																																																																									
6:	10.0	→																																																																									
7:	10.0	↗																																																																									
8:	9.9	↗																																																																									
9:	9.8	↑																																																																									
10:	10.4x	↑																																																																									
<b>Serie</b>		<b>100.3</b>																																																																									
<b>Total</b>		<b>100.3</b>																																																																									
11:	10.2x	→																																																																									
12:	10.1	→																																																																									
13:	10.6x	↖																																																																									
14:	10.6x	↓																																																																									
15:	10.2x	→																																																																									
16:	9.3	↗																																																																									
17:	10.6x	→																																																																									
18:	10.3x	↓																																																																									
19:	10.2x	→																																																																									
20:	9.1	→																																																																									
<b>Serie</b>		<b>101.2</b>																																																																									
<b>Total</b>		<b>201.5</b>																																																																									
<p><b>60 Skott</b></p>	<table border="1" style="width:100%; border-collapse: collapse;"> <tr><td>21:</td><td>10.3x</td><td>→</td></tr> <tr><td>22:</td><td>10.6x</td><td>↑</td></tr> <tr><td>23:</td><td>10.7x</td><td>→</td></tr> <tr><td>24:</td><td>10.0</td><td>↗</td></tr> <tr><td>25:</td><td>10.4x</td><td>→</td></tr> <tr><td>26:</td><td>9.9</td><td>↓</td></tr> <tr><td>27:</td><td>10.1</td><td>→</td></tr> <tr><td>28:</td><td>10.1</td><td>↖</td></tr> <tr><td>29:</td><td>10.1</td><td>←</td></tr> <tr><td>30:</td><td>10.4x</td><td>→</td></tr> <tr><td colspan="2"><b>Serie</b></td><td style="text-align: right;"><b>102.6</b></td></tr> <tr><td colspan="2"><b>Total</b></td><td style="text-align: right;"><b>304.1</b></td></tr> </table>	21:	10.3x	→	22:	10.6x	↑	23:	10.7x	→	24:	10.0	↗	25:	10.4x	→	26:	9.9	↓	27:	10.1	→	28:	10.1	↖	29:	10.1	←	30:	10.4x	→	<b>Serie</b>		<b>102.6</b>	<b>Total</b>		<b>304.1</b>	<p><b>60 Skott</b></p>	<table border="1" style="width:100%; border-collapse: collapse;"> <tr><td>31:</td><td>9.4</td><td>↓</td></tr> <tr><td>32:</td><td>10.0</td><td>↑</td></tr> <tr><td>33:</td><td>10.4x</td><td>↖</td></tr> <tr><td>34:</td><td>9.5</td><td>↑</td></tr> <tr><td>35:</td><td>10.1</td><td>↓</td></tr> <tr><td>36:</td><td>10.8x</td><td>↓</td></tr> <tr><td>37:</td><td>10.9x</td><td>→</td></tr> <tr><td>38:</td><td>10.2x</td><td>↓</td></tr> <tr><td>39:</td><td>9.9</td><td>→</td></tr> <tr><td>40:</td><td>9.8</td><td>↗</td></tr> <tr><td colspan="2"><b>Serie</b></td><td style="text-align: right;"><b>101.0</b></td></tr> <tr><td colspan="2"><b>Total</b></td><td style="text-align: right;"><b>405.1</b></td></tr> </table>	31:	9.4	↓	32:	10.0	↑	33:	10.4x	↖	34:	9.5	↑	35:	10.1	↓	36:	10.8x	↓	37:	10.9x	→	38:	10.2x	↓	39:	9.9	→	40:	9.8	↗	<b>Serie</b>		<b>101.0</b>	<b>Total</b>		<b>405.1</b>
21:	10.3x	→																																																																									
22:	10.6x	↑																																																																									
23:	10.7x	→																																																																									
24:	10.0	↗																																																																									
25:	10.4x	→																																																																									
26:	9.9	↓																																																																									
27:	10.1	→																																																																									
28:	10.1	↖																																																																									
29:	10.1	←																																																																									
30:	10.4x	→																																																																									
<b>Serie</b>		<b>102.6</b>																																																																									
<b>Total</b>		<b>304.1</b>																																																																									
31:	9.4	↓																																																																									
32:	10.0	↑																																																																									
33:	10.4x	↖																																																																									
34:	9.5	↑																																																																									
35:	10.1	↓																																																																									
36:	10.8x	↓																																																																									
37:	10.9x	→																																																																									
38:	10.2x	↓																																																																									
39:	9.9	→																																																																									
40:	9.8	↗																																																																									
<b>Serie</b>		<b>101.0</b>																																																																									
<b>Total</b>		<b>405.1</b>																																																																									
<p><b>60 Skott</b></p>	<table border="1" style="width:100%; border-collapse: collapse;"> <tr><td>41:</td><td>10.1</td><td>↑</td></tr> <tr><td>42:</td><td>10.2x</td><td>↓</td></tr> <tr><td>43:</td><td>9.9</td><td>→</td></tr> <tr><td>44:</td><td>10.3x</td><td>↖</td></tr> <tr><td>45:</td><td>10.7x</td><td>↑</td></tr> <tr><td>46:</td><td>9.9</td><td>↑</td></tr> <tr><td>47:</td><td>10.3x</td><td>↗</td></tr> <tr><td>48:</td><td>10.7x</td><td>↖</td></tr> <tr><td>49:</td><td>10.5x</td><td>←</td></tr> <tr><td>50:</td><td>10.2x</td><td>↘</td></tr> <tr><td colspan="2"><b>Serie</b></td><td style="text-align: right;"><b>102.8</b></td></tr> <tr><td colspan="2"><b>Total</b></td><td style="text-align: right;"><b>507.9</b></td></tr> </table>	41:	10.1	↑	42:	10.2x	↓	43:	9.9	→	44:	10.3x	↖	45:	10.7x	↑	46:	9.9	↑	47:	10.3x	↗	48:	10.7x	↖	49:	10.5x	←	50:	10.2x	↘	<b>Serie</b>		<b>102.8</b>	<b>Total</b>		<b>507.9</b>	<p><b>60 Skott</b></p>	<table border="1" style="width:100%; border-collapse: collapse;"> <tr><td>51:</td><td>10.5x</td><td>←</td></tr> <tr><td>52:</td><td>9.9</td><td>←</td></tr> <tr><td>53:</td><td>10.6x</td><td>←</td></tr> <tr><td>54:</td><td>9.5</td><td>↗</td></tr> <tr><td>55:</td><td>10.1</td><td>↑</td></tr> <tr><td>56:</td><td>10.0</td><td>↖</td></tr> <tr><td>57:</td><td>10.2x</td><td>↘</td></tr> <tr><td>58:</td><td>10.5x</td><td>↑</td></tr> <tr><td>59:</td><td>10.1</td><td>←</td></tr> <tr><td>60:</td><td>9.6</td><td>↗</td></tr> <tr><td colspan="2"><b>Serie</b></td><td style="text-align: right;"><b>101.0</b></td></tr> <tr><td colspan="2"><b>Total</b></td><td style="text-align: right;"><b>608.9</b></td></tr> </table>	51:	10.5x	←	52:	9.9	←	53:	10.6x	←	54:	9.5	↗	55:	10.1	↑	56:	10.0	↖	57:	10.2x	↘	58:	10.5x	↑	59:	10.1	←	60:	9.6	↗	<b>Serie</b>		<b>101.0</b>	<b>Total</b>		<b>608.9</b>
41:	10.1	↑																																																																									
42:	10.2x	↓																																																																									
43:	9.9	→																																																																									
44:	10.3x	↖																																																																									
45:	10.7x	↑																																																																									
46:	9.9	↑																																																																									
47:	10.3x	↗																																																																									
48:	10.7x	↖																																																																									
49:	10.5x	←																																																																									
50:	10.2x	↘																																																																									
<b>Serie</b>		<b>102.8</b>																																																																									
<b>Total</b>		<b>507.9</b>																																																																									
51:	10.5x	←																																																																									
52:	9.9	←																																																																									
53:	10.6x	←																																																																									
54:	9.5	↗																																																																									
55:	10.1	↑																																																																									
56:	10.0	↖																																																																									
57:	10.2x	↘																																																																									
58:	10.5x	↑																																																																									
59:	10.1	←																																																																									
60:	9.6	↗																																																																									
<b>Serie</b>		<b>101.0</b>																																																																									
<b>Total</b>		<b>608.9</b>																																																																									

Skjutlag	Tavla	Kristoffer Eriksson	
3	17	Vindeln	Äker-Länna
18.03.2017	SM & JSM Luftgevär 2017	Ramselefors SKF	
<b>Pröv</b> 	1: 9.5 → 2: 10.2x ↑ 3: 9.7 ↑ 4: 9.8 ↑ 5: 9.6 ↑ 6: 9.2 ↖ 7: 10.0 ↑ 8: 10.2x ↑ 9: 10.1 ↖ 10: 9.7 ↖	<b>Pröv</b> 	11: 10.2x → 12: 8.9 ← 13: 9.7 ← 14: 10.1 ← 15: 10.2x →
	Serie 98.0		Serie 49.1
	Total 0.0		Total 0.0
<b>60 Skott</b> 	1: 10.8x ↓ 2: 10.4x → 3: 10.7x → 4: 10.2x ↓ 5: 10.7x ↓ 6: 8.7 → 7: 10.1 ↓ 8: 10.5x ↓ 9: 10.5x ↓ 10: 9.8 ←	<b>60 Skott</b> 	11: 9.6 ← 12: 10.5x ↖ 13: 10.2x ↓ 14: 10.5x → 15: 10.8x → 16: 9.8 ← 17: 10.1 ← 18: 10.4x ↓ 19: 10.5x ← 20: 9.5 ←
	Serie 102.4		Serie 101.9
	Total 102.4		Total 204.3
<b>60 Skott</b> 	21: 10.5x ↖ 22: 10.4x ↓ 23: 10.0 ↓ 24: 9.1 ← 25: 10.1 ← 26: 10.5x ↖ 27: 9.5 ↓ 28: 10.2x ↓ 29: 10.5x ↓ 30: 9.6 ↓	<b>60 Skott</b> 	31: 9.8 ↓ 32: 10.7x ↓ 33: 10.0 ← 34: 10.3x → 35: 10.5x → 36: 10.2x ← 37: 9.5 ↓ 38: 10.3x ↓ 39: 10.5x → 40: 10.6x →
	Serie 100.4		Serie 102.4
	Total 304.7		Total 407.1
<b>60 Skott</b> 	41: 10.4x ↖ 42: 10.2x ↓ 43: 9.6 ↓ 44: 9.8 ← 45: 9.8 ↓ 46: 9.3 ↖ 47: 9.9 ↑ 48: 10.1 ↓ 49: 9.9 ↓ 50: 9.5 ↖	<b>60 Skott</b> 	51: 10.3x ← 52: 9.4 ↓ 53: 9.9 ↓ 54: 9.9 → 55: 10.3x ← 56: 10.3x ↑ 57: 9.6 ↖ 58: 10.0 ↓ 59: 9.7 ← 60: 9.2 ←
	Serie 98.5		Serie 98.6
	Total 505.6		Total 604.2

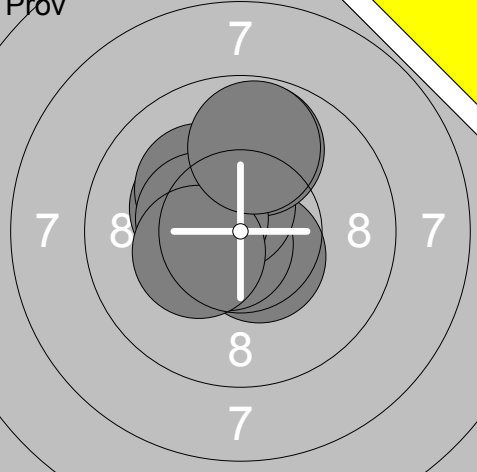
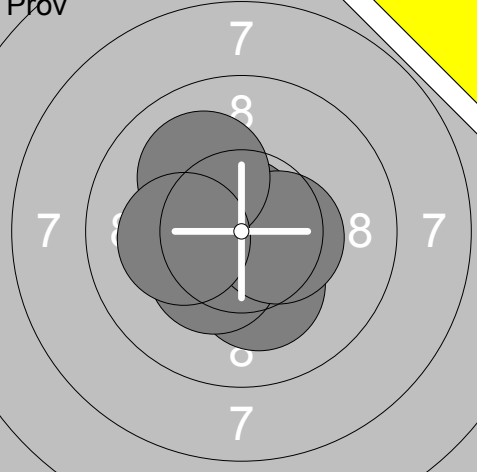
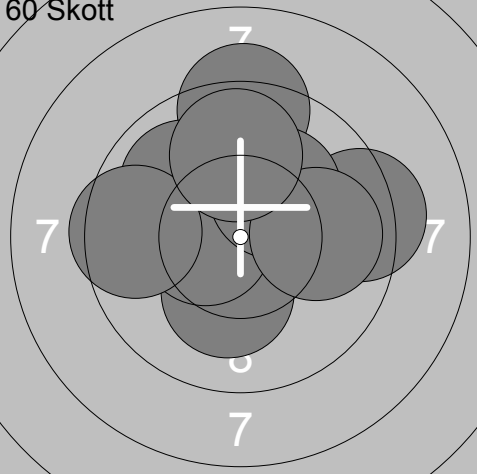
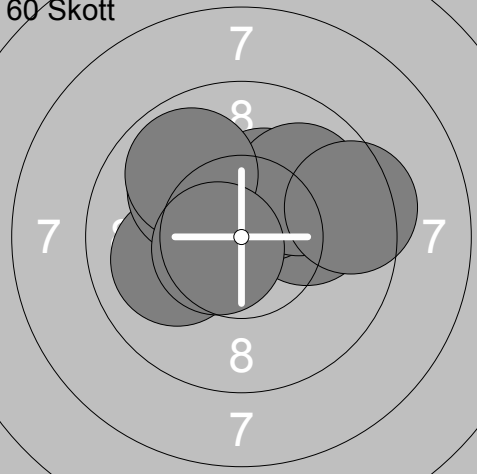
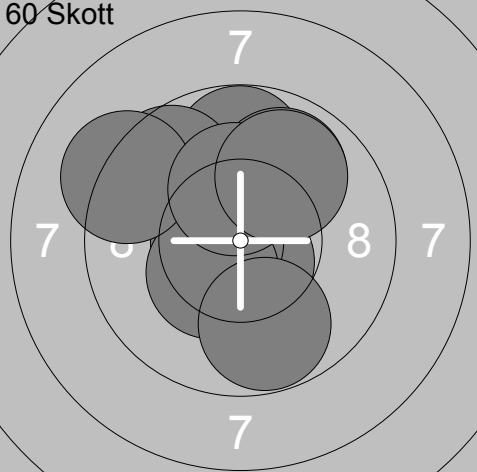
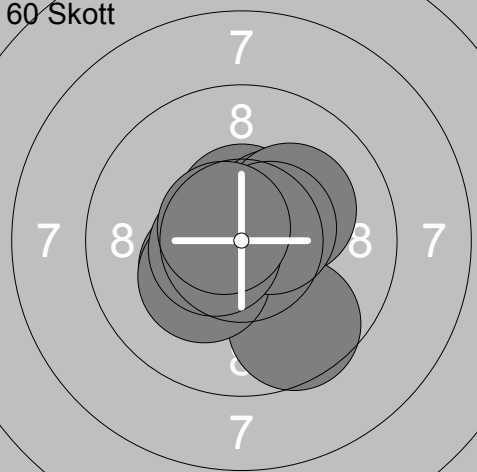
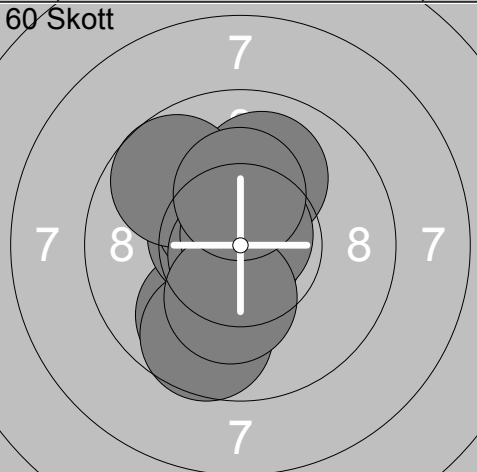
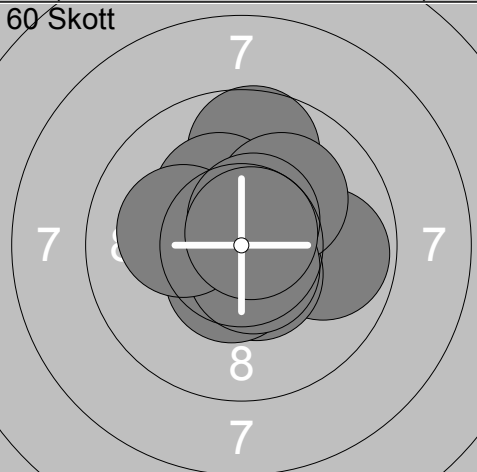

<p><b>Prov</b></p>	<table border="1" style="width:100%; border-collapse: collapse;"> <tr><td>1:</td><td>8.3</td><td>↑</td></tr> <tr><td>2:</td><td>7.5</td><td>↑</td></tr> <tr><td>3:</td><td>9.7</td><td>↓</td></tr> <tr><td>4:</td><td>10.6x</td><td>↓</td></tr> <tr><td>5:</td><td>9.1</td><td>↓</td></tr> <tr><td>6:</td><td>10.6x</td><td>←</td></tr> <tr><td>7:</td><td>9.8</td><td>←</td></tr> <tr><td>8:</td><td>10.6x</td><td>↑</td></tr> <tr><td>9:</td><td>10.0</td><td>↑</td></tr> <tr><td>10:</td><td>9.8</td><td>→</td></tr> <tr><td colspan="2"><b>Serie</b></td><td><b>96.0</b></td></tr> <tr><td colspan="2"><b>Total</b></td><td><b>0.0</b></td></tr> </table>	1:	8.3	↑	2:	7.5	↑	3:	9.7	↓	4:	10.6x	↓	5:	9.1	↓	6:	10.6x	←	7:	9.8	←	8:	10.6x	↑	9:	10.0	↑	10:	9.8	→	<b>Serie</b>		<b>96.0</b>	<b>Total</b>		<b>0.0</b>	<p><b>Prov</b></p>	<table border="1" style="width:100%; border-collapse: collapse;"> <tr><td>11:</td><td>10.7x</td><td>↓</td></tr> <tr><td>12:</td><td>10.0</td><td>←</td></tr> <tr><td>13:</td><td>9.5</td><td>←</td></tr> <tr><td>14:</td><td>9.2</td><td>↖</td></tr> <tr><td>15:</td><td>10.2x</td><td>↗</td></tr> <tr><td>16:</td><td>9.8</td><td>↑</td></tr> <tr><td colspan="2"><b>Serie</b></td><td><b>59.4</b></td></tr> <tr><td colspan="2"><b>Total</b></td><td><b>0.0</b></td></tr> </table>	11:	10.7x	↓	12:	10.0	←	13:	9.5	←	14:	9.2	↖	15:	10.2x	↗	16:	9.8	↑	<b>Serie</b>		<b>59.4</b>	<b>Total</b>		<b>0.0</b>												
1:	8.3	↑																																																																									
2:	7.5	↑																																																																									
3:	9.7	↓																																																																									
4:	10.6x	↓																																																																									
5:	9.1	↓																																																																									
6:	10.6x	←																																																																									
7:	9.8	←																																																																									
8:	10.6x	↑																																																																									
9:	10.0	↑																																																																									
10:	9.8	→																																																																									
<b>Serie</b>		<b>96.0</b>																																																																									
<b>Total</b>		<b>0.0</b>																																																																									
11:	10.7x	↓																																																																									
12:	10.0	←																																																																									
13:	9.5	←																																																																									
14:	9.2	↖																																																																									
15:	10.2x	↗																																																																									
16:	9.8	↑																																																																									
<b>Serie</b>		<b>59.4</b>																																																																									
<b>Total</b>		<b>0.0</b>																																																																									
<p><b>60 Skott</b></p>	<table border="1" style="width:100%; border-collapse: collapse;"> <tr><td>1:</td><td>10.3x</td><td>↑</td></tr> <tr><td>2:</td><td>10.1</td><td>↑</td></tr> <tr><td>3:</td><td>10.4x</td><td>↗</td></tr> <tr><td>4:</td><td>10.8x</td><td>↑</td></tr> <tr><td>5:</td><td>10.3x</td><td>↓</td></tr> <tr><td>6:</td><td>10.7x</td><td>→</td></tr> <tr><td>7:</td><td>10.4x</td><td>←</td></tr> <tr><td>8:</td><td>10.4x</td><td>→</td></tr> <tr><td>9:</td><td>10.7x</td><td>↗</td></tr> <tr><td>10:</td><td>9.6</td><td>←</td></tr> <tr><td colspan="2"><b>Serie</b></td><td><b>103.7</b></td></tr> <tr><td colspan="2"><b>Total</b></td><td><b>103.7</b></td></tr> </table>	1:	10.3x	↑	2:	10.1	↑	3:	10.4x	↗	4:	10.8x	↑	5:	10.3x	↓	6:	10.7x	→	7:	10.4x	←	8:	10.4x	→	9:	10.7x	↗	10:	9.6	←	<b>Serie</b>		<b>103.7</b>	<b>Total</b>		<b>103.7</b>	<p><b>60 Skott</b></p>	<table border="1" style="width:100%; border-collapse: collapse;"> <tr><td>11:</td><td>10.2x</td><td>←</td></tr> <tr><td>12:</td><td>10.0</td><td>↓</td></tr> <tr><td>13:</td><td>10.0</td><td>↓</td></tr> <tr><td>14:</td><td>10.4x</td><td>←</td></tr> <tr><td>15:</td><td>10.4x</td><td>↑</td></tr> <tr><td>16:</td><td>10.3x</td><td>↗</td></tr> <tr><td>17:</td><td>10.8x</td><td>↓</td></tr> <tr><td>18:</td><td>10.0</td><td>←</td></tr> <tr><td>19:</td><td>10.5x</td><td>↖</td></tr> <tr><td>20:</td><td>10.6x</td><td>←</td></tr> <tr><td colspan="2"><b>Serie</b></td><td><b>103.2</b></td></tr> <tr><td colspan="2"><b>Total</b></td><td><b>206.9</b></td></tr> </table>	11:	10.2x	←	12:	10.0	↓	13:	10.0	↓	14:	10.4x	←	15:	10.4x	↑	16:	10.3x	↗	17:	10.8x	↓	18:	10.0	←	19:	10.5x	↖	20:	10.6x	←	<b>Serie</b>		<b>103.2</b>	<b>Total</b>		<b>206.9</b>
1:	10.3x	↑																																																																									
2:	10.1	↑																																																																									
3:	10.4x	↗																																																																									
4:	10.8x	↑																																																																									
5:	10.3x	↓																																																																									
6:	10.7x	→																																																																									
7:	10.4x	←																																																																									
8:	10.4x	→																																																																									
9:	10.7x	↗																																																																									
10:	9.6	←																																																																									
<b>Serie</b>		<b>103.7</b>																																																																									
<b>Total</b>		<b>103.7</b>																																																																									
11:	10.2x	←																																																																									
12:	10.0	↓																																																																									
13:	10.0	↓																																																																									
14:	10.4x	←																																																																									
15:	10.4x	↑																																																																									
16:	10.3x	↗																																																																									
17:	10.8x	↓																																																																									
18:	10.0	←																																																																									
19:	10.5x	↖																																																																									
20:	10.6x	←																																																																									
<b>Serie</b>		<b>103.2</b>																																																																									
<b>Total</b>		<b>206.9</b>																																																																									
<p><b>60 Skott</b></p>	<table border="1" style="width:100%; border-collapse: collapse;"> <tr><td>21:</td><td>9.8</td><td>↖</td></tr> <tr><td>22:</td><td>9.1</td><td>→</td></tr> <tr><td>23:</td><td>9.7</td><td>↑</td></tr> <tr><td>24:</td><td>9.8</td><td>←</td></tr> <tr><td>25:</td><td>10.7x</td><td>↓</td></tr> <tr><td>26:</td><td>10.4x</td><td>↓</td></tr> <tr><td>27:</td><td>9.8</td><td>↑</td></tr> <tr><td>28:</td><td>10.0</td><td>←</td></tr> <tr><td>29:</td><td>10.6x</td><td>↓</td></tr> <tr><td>30:</td><td>9.7</td><td>↑</td></tr> <tr><td colspan="2"><b>Serie</b></td><td><b>99.6</b></td></tr> <tr><td colspan="2"><b>Total</b></td><td><b>306.5</b></td></tr> </table>	21:	9.8	↖	22:	9.1	→	23:	9.7	↑	24:	9.8	←	25:	10.7x	↓	26:	10.4x	↓	27:	9.8	↑	28:	10.0	←	29:	10.6x	↓	30:	9.7	↑	<b>Serie</b>		<b>99.6</b>	<b>Total</b>		<b>306.5</b>	<p><b>60 Skott</b></p>	<table border="1" style="width:100%; border-collapse: collapse;"> <tr><td>31:</td><td>10.1</td><td>↗</td></tr> <tr><td>32:</td><td>10.3x</td><td>↑</td></tr> <tr><td>33:</td><td>10.2x</td><td>↓</td></tr> <tr><td>34:</td><td>9.7</td><td>→</td></tr> <tr><td>35:</td><td>10.5x</td><td>←</td></tr> <tr><td>36:</td><td>10.5x</td><td>←</td></tr> <tr><td>37:</td><td>10.0</td><td>↓</td></tr> <tr><td>38:</td><td>9.7</td><td>←</td></tr> <tr><td>39:</td><td>10.5x</td><td>→</td></tr> <tr><td>40:</td><td>10.7x</td><td>↓</td></tr> <tr><td colspan="2"><b>Serie</b></td><td><b>102.2</b></td></tr> <tr><td colspan="2"><b>Total</b></td><td><b>408.7</b></td></tr> </table>	31:	10.1	↗	32:	10.3x	↑	33:	10.2x	↓	34:	9.7	→	35:	10.5x	←	36:	10.5x	←	37:	10.0	↓	38:	9.7	←	39:	10.5x	→	40:	10.7x	↓	<b>Serie</b>		<b>102.2</b>	<b>Total</b>		<b>408.7</b>
21:	9.8	↖																																																																									
22:	9.1	→																																																																									
23:	9.7	↑																																																																									
24:	9.8	←																																																																									
25:	10.7x	↓																																																																									
26:	10.4x	↓																																																																									
27:	9.8	↑																																																																									
28:	10.0	←																																																																									
29:	10.6x	↓																																																																									
30:	9.7	↑																																																																									
<b>Serie</b>		<b>99.6</b>																																																																									
<b>Total</b>		<b>306.5</b>																																																																									
31:	10.1	↗																																																																									
32:	10.3x	↑																																																																									
33:	10.2x	↓																																																																									
34:	9.7	→																																																																									
35:	10.5x	←																																																																									
36:	10.5x	←																																																																									
37:	10.0	↓																																																																									
38:	9.7	←																																																																									
39:	10.5x	→																																																																									
40:	10.7x	↓																																																																									
<b>Serie</b>		<b>102.2</b>																																																																									
<b>Total</b>		<b>408.7</b>																																																																									
<p><b>60 Skott</b></p>	<table border="1" style="width:100%; border-collapse: collapse;"> <tr><td>41:</td><td>9.3</td><td>←</td></tr> <tr><td>42:</td><td>10.2x</td><td>←</td></tr> <tr><td>43:</td><td>9.7</td><td>←</td></tr> <tr><td>44:</td><td>9.6</td><td>↓</td></tr> <tr><td>45:</td><td>9.2</td><td>↓</td></tr> <tr><td>46:</td><td>10.6x</td><td>↑</td></tr> <tr><td>47:</td><td>10.5x</td><td>←</td></tr> <tr><td>48:</td><td>10.1</td><td>↓</td></tr> <tr><td>49:</td><td>10.2x</td><td>↓</td></tr> <tr><td>50:</td><td>10.4x</td><td>←</td></tr> <tr><td colspan="2"><b>Serie</b></td><td><b>99.8</b></td></tr> <tr><td colspan="2"><b>Total</b></td><td><b>508.5</b></td></tr> </table>	41:	9.3	←	42:	10.2x	←	43:	9.7	←	44:	9.6	↓	45:	9.2	↓	46:	10.6x	↑	47:	10.5x	←	48:	10.1	↓	49:	10.2x	↓	50:	10.4x	←	<b>Serie</b>		<b>99.8</b>	<b>Total</b>		<b>508.5</b>	<p><b>60 Skott</b></p>	<table border="1" style="width:100%; border-collapse: collapse;"> <tr><td>51:</td><td>10.6x</td><td>↓</td></tr> <tr><td>52:</td><td>10.0</td><td>↑</td></tr> <tr><td>53:</td><td>10.3x</td><td>↓</td></tr> <tr><td>54:</td><td>10.2x</td><td>↑</td></tr> <tr><td>55:</td><td>10.5x</td><td>←</td></tr> <tr><td>56:</td><td>9.5</td><td>↖</td></tr> <tr><td>57:</td><td>9.9</td><td>↗</td></tr> <tr><td>58:</td><td>9.3</td><td>↗</td></tr> <tr><td>59:</td><td>9.7</td><td>↗</td></tr> <tr><td>60:</td><td>9.3</td><td>↗</td></tr> <tr><td colspan="2"><b>Serie</b></td><td><b>99.3</b></td></tr> <tr><td colspan="2"><b>Total</b></td><td><b>607.8</b></td></tr> </table>	51:	10.6x	↓	52:	10.0	↑	53:	10.3x	↓	54:	10.2x	↑	55:	10.5x	←	56:	9.5	↖	57:	9.9	↗	58:	9.3	↗	59:	9.7	↗	60:	9.3	↗	<b>Serie</b>		<b>99.3</b>	<b>Total</b>		<b>607.8</b>
41:	9.3	←																																																																									
42:	10.2x	←																																																																									
43:	9.7	←																																																																									
44:	9.6	↓																																																																									
45:	9.2	↓																																																																									
46:	10.6x	↑																																																																									
47:	10.5x	←																																																																									
48:	10.1	↓																																																																									
49:	10.2x	↓																																																																									
50:	10.4x	←																																																																									
<b>Serie</b>		<b>99.8</b>																																																																									
<b>Total</b>		<b>508.5</b>																																																																									
51:	10.6x	↓																																																																									
52:	10.0	↑																																																																									
53:	10.3x	↓																																																																									
54:	10.2x	↑																																																																									
55:	10.5x	←																																																																									
56:	9.5	↖																																																																									
57:	9.9	↗																																																																									
58:	9.3	↗																																																																									
59:	9.7	↗																																																																									
60:	9.3	↗																																																																									
<b>Serie</b>		<b>99.3</b>																																																																									
<b>Total</b>		<b>607.8</b>																																																																									

<b>Pröv</b> 	1: 10.6x ↙ 2: 10.3x ↖ 3: 10.5x ↘ 4: 10.7x ↙ 5: 10.6x ↗ 6: 10.2x ↗ 7: 9.8 ↗ 8: 10.4x ↖ 9: 10.3x ↖ 10: 9.8 ↗ <hr/> Serie 103.2 Total 0.0	<b>Pröv</b> 	11: 10.8x ↘ 12: 10.8x ↗ 13: 10.2x ↘ 14: 10.6x ↖ 15: 10.4x ↖ 16: 10.3x ↘ 17: 10.5x → 18: 10.1 ↗ 19: 10.2x ↖ <hr/> Serie 93.9 Total 0.0
<b>60 Skott</b> 	1: 9.2 ↗ 2: 10.2x ↘ 3: 9.3 → 4: 10.3x ↗ 5: 9.9 ↗ 6: 10.5x ↖ 7: 9.5 ↖ 8: 10.2x ↗ 9: 9.9 → 10: 9.8 ↗ <hr/> Serie 98.8 Total 98.8	<b>60 Skott</b> 	11: 10.6x ↖ 12: 10.0 → 13: 10.4x ↗ 14: 10.0 ↖ 15: 10.3x ↗ 16: 10.0 ↗ 17: 9.9 ↗ 18: 9.9 ↗ 19: 9.4 → 20: 10.6x ↖ <hr/> Serie 101.1 Total 199.9
<b>60 Skott</b> 	21: 9.8 ↗ 22: 9.6 ↗ 23: 10.6x ↘ 24: 10.6x ↖ 25: 10.4x ↘ 26: 9.9 ↗ 27: 9.2 ↗ 28: 10.3x ↗ 29: 9.9 ↗ 30: 9.8 ↘ <hr/> Serie 100.1 Total 300.0	<b>60 Skott</b> 	31: 10.5x ↘ 32: 10.3x ↖ 33: 10.5x ↗ 34: 10.4x ↗ 35: 10.2x ↗ 36: 9.6 ↘ 37: 10.3x ↖ 38: 10.5x → 39: 10.6x ↖ 40: 10.7x ↖ <hr/> Serie 103.6 Total 403.6
<b>60 Skott</b> 	41: 9.9 ↘ 42: 9.7 ↘ 43: 10.0 ↗ 44: 10.6x ↖ 45: 10.5x ↗ 46: 9.7 ↗ 47: 10.8x ↘ 48: 10.8x ↗ 49: 10.2x ↘ 50: 10.3x ↗ <hr/> Serie 102.5 Total 506.1	<b>60 Skott</b> 	51: 9.7 ↗ 52: 9.8 → 53: 10.3x ↗ 54: 10.5x ↘ 55: 10.5x ↘ 56: 10.1 ↗ 57: 10.6x ↘ 58: 10.1 ↖ 59: 10.6x ↗ 60: 10.7x ↗ <hr/> Serie 102.9 Total 609.0

<p>Pröv</p>	<p>1: 9.8 ↑ 2: 9.3 ↑ 3: 10.2x ↑ 4: 10.7x ↗ 5: 10.8x ↗ 6: 9.6 ↗ 7: 10.5x ↖ 8: 10.4x ↖ 9: 10.8x → 10: 10.2x →</p> <p>Serie 102.3 Total 0.0</p>	<p>Pröv</p>	<p>11: 10.6x ↖ 12: 10.2x ↗ 13: 10.5x ↗ 14: 10.2x ↗ 15: 10.5x ↑ 16: 9.8 ↘ 17: 10.8x ↗ 18: 10.2x ↓ 19: 10.2x ↖</p> <p>Serie 93.0 Total 0.0</p>
<p>60 Skott</p>	<p>1: 10.7x → 2: 10.4x → 3: 10.1 ↗ 4: 10.8x ↑ 5: 10.1 → 6: 10.3x → 7: 9.5 ↗ 8: 10.7x ↖ 9: 9.7 → 10: 10.2x ↘</p> <p>Serie 102.5 Total 102.5</p>	<p>60 Skott</p>	<p>11: 10.7x ↖ 12: 10.5x ↑ 13: 10.8x ↘ 14: 10.1 ↘ 15: 9.4 → 16: 10.8x ↗ 17: 9.1 → 18: 10.4x ↘ 19: 10.8x ↖ 20: 9.9 ↘</p> <p>Serie 102.5 Total 205.0</p>
<p>60 Skott</p>	<p>21: 9.9 ↓ 22: 9.7 → 23: 9.7 ↘ 24: 10.2x ↘ 25: 10.8x ↘ 26: 10.4x ↖ 27: 9.8 ↖ 28: 9.7 ↗ 29: 10.5x ↗ 30: 10.0 ↗</p> <p>Serie 100.7 Total 305.7</p>	<p>60 Skott</p>	<p>31: 10.4x ↗ 32: 10.6x ↖ 33: 10.3x ↖ 34: 10.6x ↘ 35: 10.8x ↑ 36: 10.4x ↖ 37: 10.0 ↗ 38: 10.2x → 39: 10.0 ↗ 40: 10.4x ↗</p> <p>Serie 103.7 Total 409.4</p>
<p>60 Skott</p>	<p>41: 10.1 ↖ 42: 10.8x ↗ 43: 10.8x ↗ 44: 9.7 ↖ 45: 9.8 → 46: 10.6x ↘ 47: 10.7x ↗ 48: 10.6x ↖ 49: 10.3x ↖ 50: 10.5x ↖</p> <p>Serie 103.9 Total 513.3</p>	<p>60 Skott</p>	<p>51: 10.5x ↖ 52: 10.4x ↗ 53: 10.3x → 54: 10.1 ↖ 55: 10.2x → 56: 10.4x ↖ 57: 10.7x ↗ 58: 10.3x → 59: 10.4x ↖ 60: 10.2x →</p> <p>Serie 103.5 Total 616.8</p>

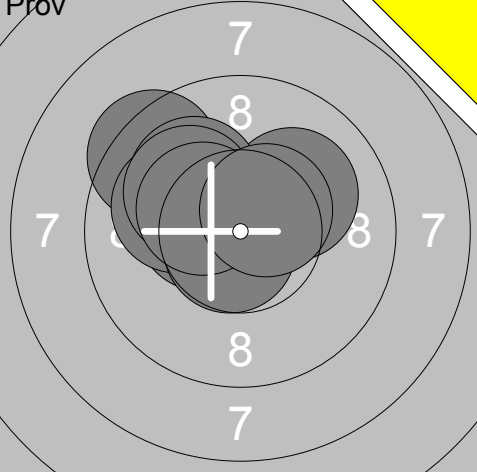
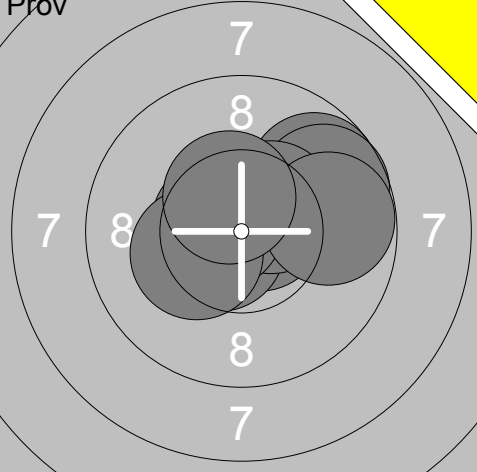
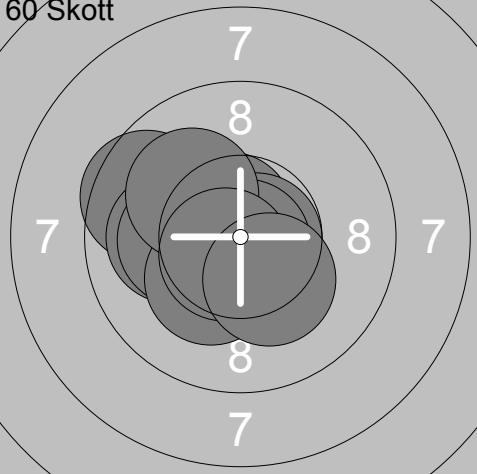
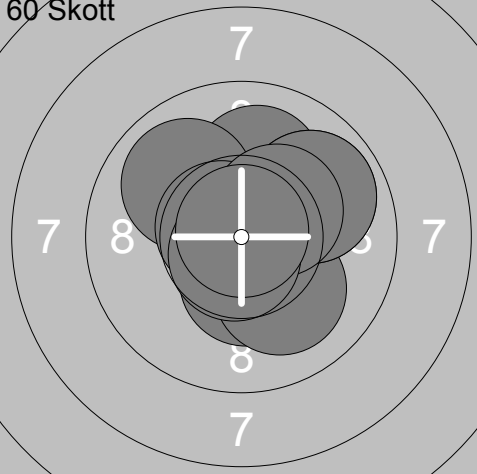
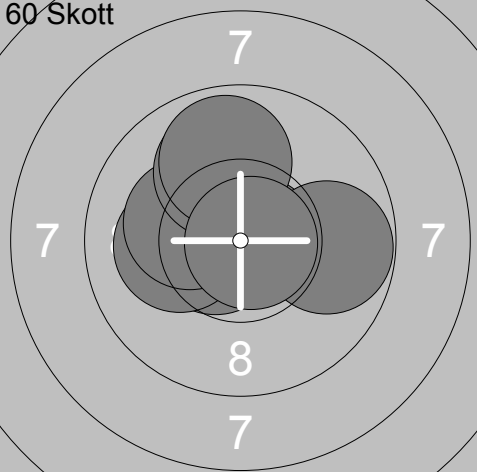
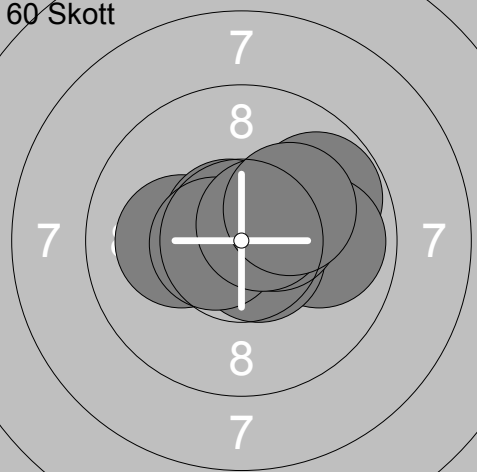
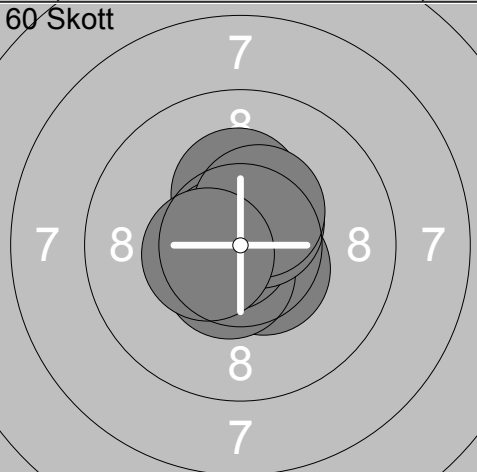
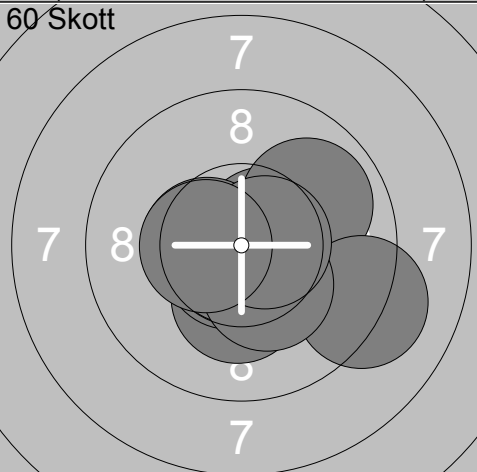
<p>Pröv</p> 	<p>1: 10.1 ↗ 2: 10.1 ↖ 3: 9.4 ↗ 4: 10.4x ↖ 5: 10.0 ↗ 6: 10.1 ↗ 7: 10.1 ↗ 8: 10.7x ↘ 9: 10.3x ↗ 10: 10.5x ↗</p> <p>Serie 101.7 Total 0.0</p>	<p>Pröv</p> 	<p>11: 10.7x ↗ 12: 9.7 ↗ 13: 9.7 ↗ 14: 10.6x ↖ 15: 10.5x ↗ 16: 10.4x ↗ 17: 10.6x ↖ 18: 9.8 → 19: 10.3x ↖ 20: 10.5x ↗</p> <p>Serie 102.8 Total 0.0</p>
<p>60 Skott</p> 	<p>1: 10.6x ↗ 2: 9.6 ↗ 3: 10.7x → 4: 10.8x ↘ 5: 10.0 ↖ 6: 10.2x ↖ 7: 10.3x ↘ 8: 10.1 ↗ 9: 10.6x ↘ 10: 10.3x ↘</p> <p>Serie 103.2 Total 103.2</p>	<p>60 Skott</p> 	<p>11: 10.0 ↗ 12: 9.9 ↖ 13: 10.4x ↘ 14: 10.1 ↘ 15: 10.7x ↖ 16: 9.9 ↗ 17: 9.9 ↗ 18: 10.4x ↗ 19: 10.7x ↘ 20: 10.9x ↗</p> <p>Serie 102.9 Total 206.1</p>
<p>60 Skott</p> 	<p>21: 10.6x ↖ 22: 10.8x → 23: 10.6x ↖ 24: 9.8 → 25: 10.1 ↖ 26: 10.3x ↗ 27: 10.2x ↗ 28: 10.0 ↗ 29: 9.9 ↗ 30: 10.8x →</p> <p>Serie 103.1 Total 309.2</p>	<p>60 Skott</p> 	<p>31: 9.9 ↗ 32: 10.1 ↖ 33: 9.8 ↗ 34: 9.9 → 35: 10.7x ↗ 36: 10.6x ↘ 37: 10.6x ↖ 38: 10.5x ↗ 39: 10.6x ↗ 40: 10.2x ↗</p> <p>Serie 102.9 Total 412.1</p>
<p>60 Skott</p> 	<p>41: 10.5x ↘ 42: 10.6x ↗ 43: 10.6x ↗ 44: 10.7x ↖ 45: 10.6x ↘ 46: 10.3x ↗ 47: 10.8x ↖ 48: 10.6x ↗ 49: 10.4x ↗ 50: 10.5x ↖</p> <p>Serie 105.6 Total 517.7</p>	<p>60 Skott</p> 	<p>51: 10.6x ↗ 52: 10.3x ↘ 53: 9.9 ↗ 54: 10.5x ↖ 55: 10.7x ↘ 56: 9.1 → 57: 10.8x ↘ 58: 10.3x ↘ 59: 10.6x → 60: 10.5x ↖</p> <p>Serie 103.3 Total 621.0</p>

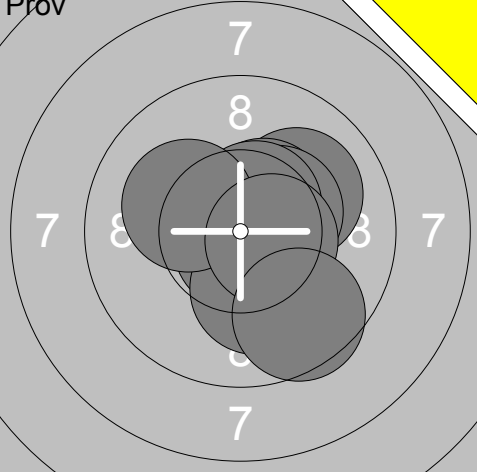
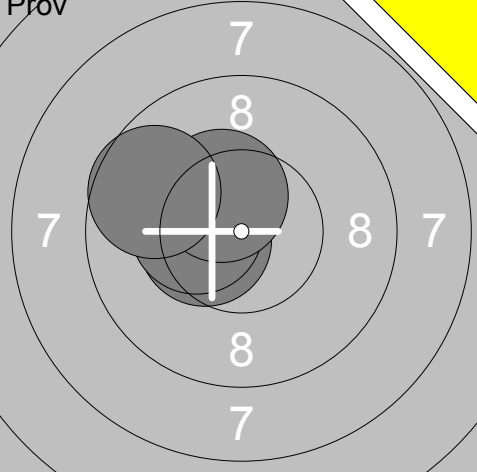
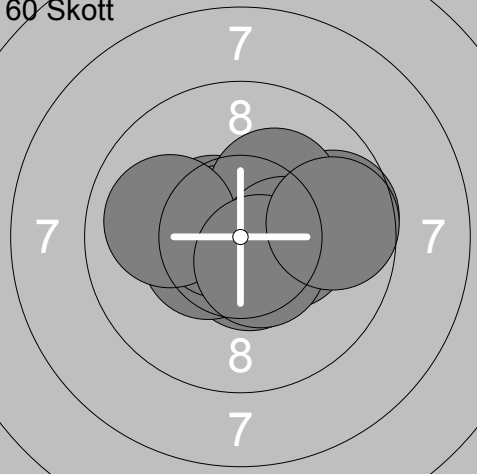
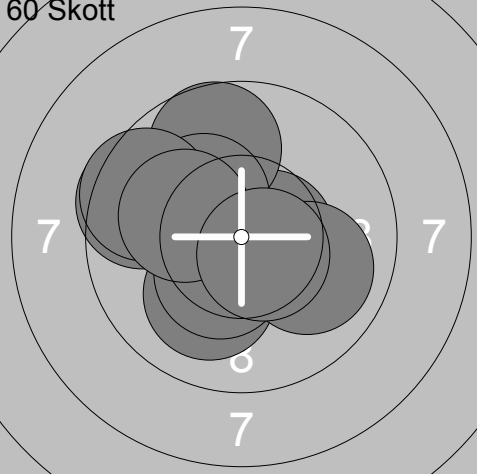
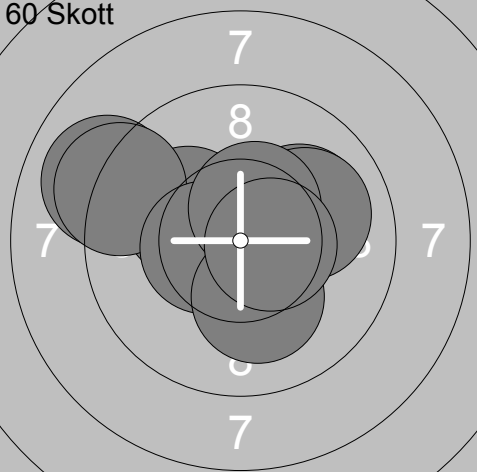
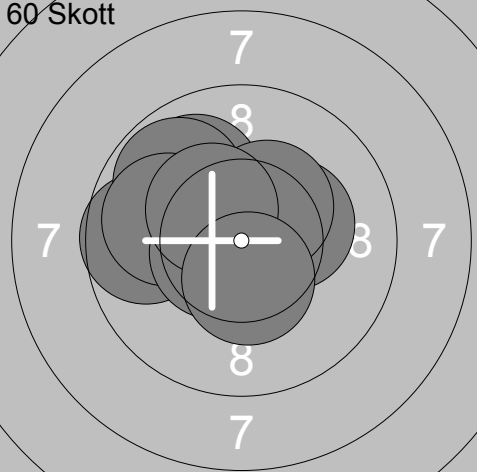
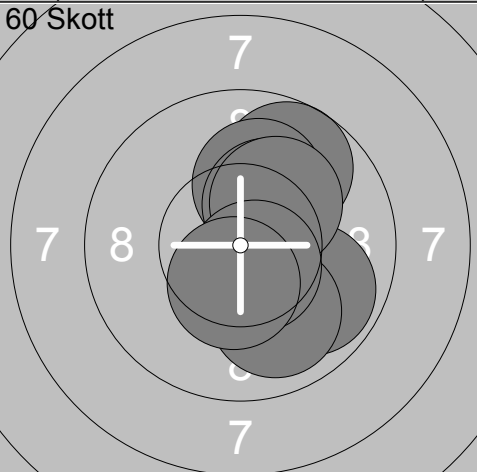
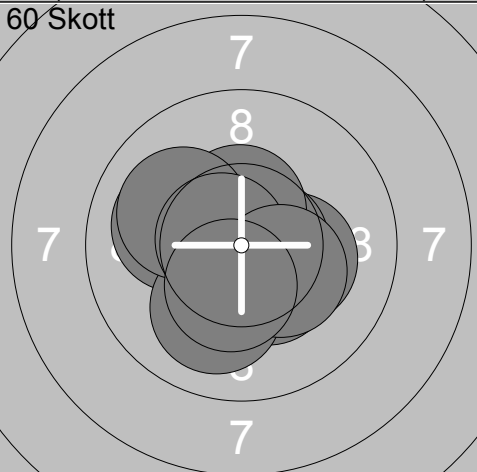
Pröv 	1: 10.6x → 2: 10.0 → 3: 10.5x ↗ 4: 10.4x → 5: 10.8x ↓ 6: 10.6x ↗ 7: 10.2x ↓ 8: 10.2x ↖ 9: 10.5x → 10: 9.6 ↓ <hr/> Serie 103.4 Total 0.0	Pröv 	11: 10.4x ← 12: 10.3x ← 13: 10.4x ↗ 14: 9.7 ↖ <hr/> Serie 40.8 Total 0.0
60 Skott 	1: 9.7 → 2: 10.6x ↓ 3: 10.5x ← 4: 10.5x ↗ 5: 10.7x ← 6: 10.2x ↗ 7: 10.3x → 8: 10.0 ← 9: 10.5x ↓ 10: 9.7 → <hr/> Serie 102.7 Total 102.7	60 Skott 	11: 10.6x → 12: 9.7 ↗ 13: 9.5 ← 14: 10.1 ↓ 15: 10.4x ↓ 16: 10.2x ↗ 17: 10.0 ↓ 18: 9.5 ↗ 19: 10.1 ↖ 20: 10.6x ↓ <hr/> Serie 100.7 Total 203.4
60 Skott 	21: 9.0 ← 22: 10.1 → 23: 10.7x ↑ 24: 10.2x ↖ 25: 10.0 → 26: 9.2 ← 27: 10.5x ← 28: 10.2x ↓ 29: 10.5x ↗ 30: 10.5x → <hr/> Serie 100.9 Total 304.3	60 Skott 	31: 9.9 ↗ 32: 10.3x → 33: 10.4x ↗ 34: 10.0 ← 35: 9.7 ← 36: 9.8 ↗ 37: 9.9 ↖ 38: 10.6x ← 39: 10.4x ↗ 40: 10.4x ↓ <hr/> Serie 101.4 Total 405.7
60 Skott 	41: 10.0 ↗ 42: 10.4x ↓ 43: 9.7 ↗ 44: 10.1 ↗ 45: 10.3x ↗ 46: 9.9 ↓ 47: 10.2x ↗ 48: 9.9 ↓ 49: 10.6x ↓ 50: 10.4x ↓ <hr/> Serie 101.5 Total 507.2	60 Skott 	51: 10.3x → 52: 10.7x → 53: 10.1 ↖ 54: 10.4x ↓ 55: 10.1 ↓ 56: 10.5x ↑ 57: 10.0 ↗ 58: 10.7x ↖ 59: 10.3x ↓ 60: 10.4x ↓ <hr/> Serie 103.5 Total 610.7

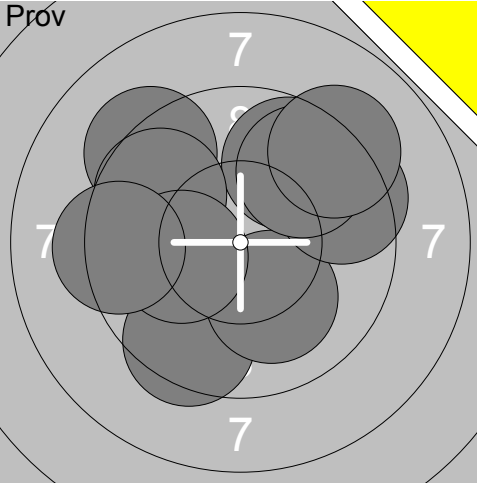
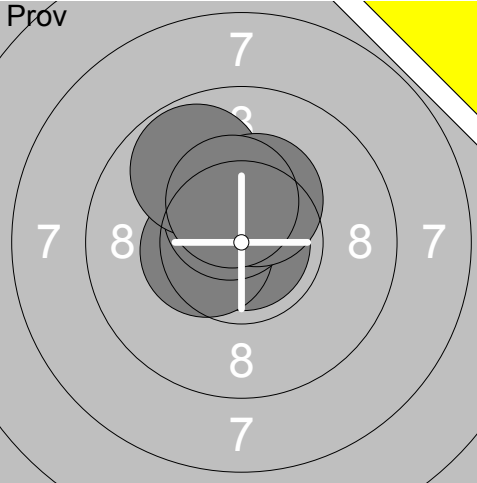
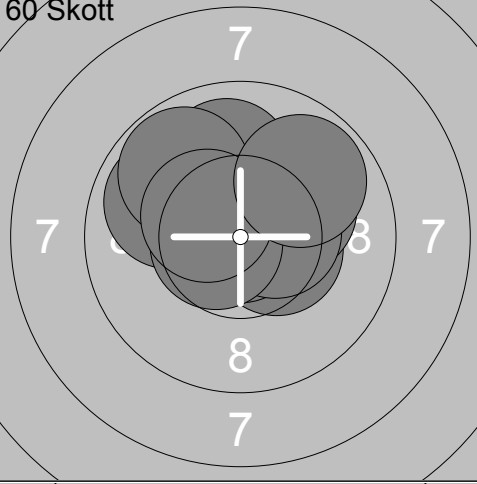
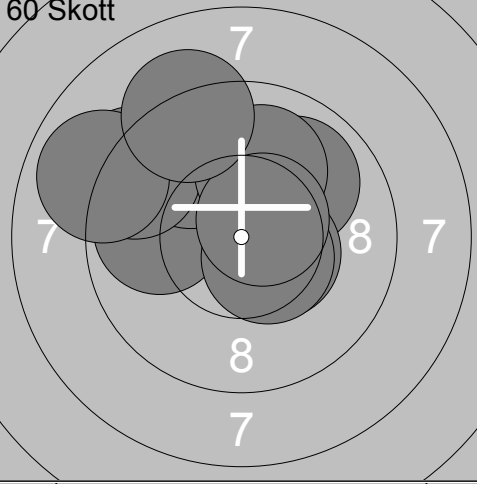
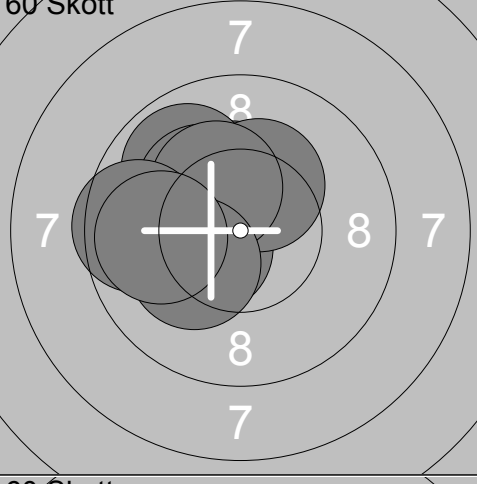
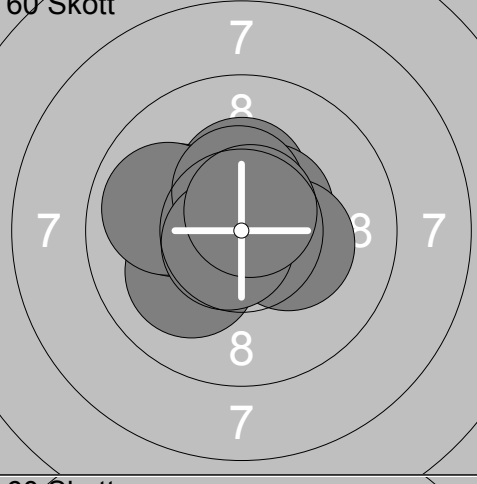
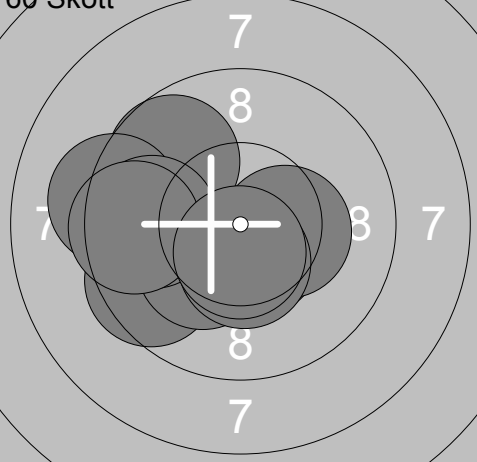
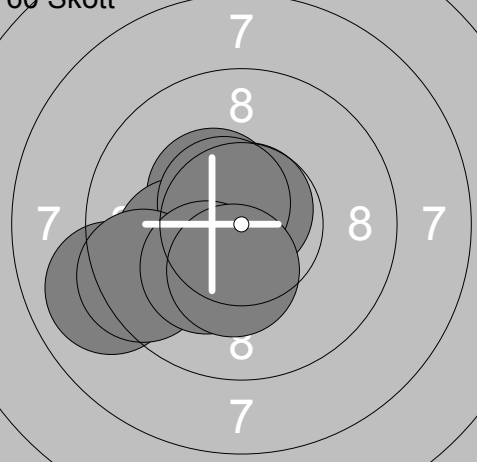
Skjutlag <b>3</b>	Tavla <b>23</b>	<b>William Grydén</b>			
Vindeln	Vaksala		Up		
18.03.2017	SM & JSM Luftgevär 2017	Ramselefors SKF			
Pröv		1: 9.2 ↗ 2: 9.7 ↗ 3: 9.5 ↘ 4: 10.1 ↘ 5: 9.7 ↗ 6: 9.5 → 7: 9.7 ↗ 8: 9.2 ↗ 9: 10.1 ← 10: 9.3 ← Serie 96.0 Total 0.0	Pröv		11: 10.9x ↘ 12: 10.5x ← 13: 10.5x ↗ 14: 9.8 ↗ 15: 10.3x ↗ 16: 10.4x ↗ Serie 62.4 Total 0.0
60 Skott		1: 9.9 ← 2: 10.4x → 3: 10.9x ↗ 4: 10.2x → 5: 10.5x → 6: 10.6x ← 7: 10.0 ↗ 8: 9.8 ↗ 9: 10.4x ↗ 10: 9.8 ↗ Serie 102.5 Total 102.5	60 Skott		11: 9.9 ↗ 12: 10.5x → 13: 9.8 ← 14: 9.7 ↗ 15: 9.3 ↗ 16: 10.0 ↗ 17: 8.9 ← 18: 10.5x → 19: 10.6x ↗ 20: 9.2 ↗ Serie 98.4 Total 200.9
60 Skott		21: 10.4x ↗ 22: 10.4x ← 23: 10.3x ↗ 24: 10.2x ↗ 25: 9.9 ↗ 26: 10.2x ↗ 27: 10.3x ↗ 28: 9.6 ← 29: 10.2x ↘ 30: 9.9 ← Serie 101.4 Total 302.3	60 Skott		31: 10.4x ↗ 32: 10.1 ← 33: 10.3x ↗ 34: 10.0 ← 35: 10.5x ↗ 36: 9.9 ← 37: 10.3x → 38: 10.4x ↗ 39: 10.7x ↘ 40: 10.7x ↗ Serie 103.3 Total 405.6
60 Skott		41: 9.5 ← 42: 9.7 ↗ 43: 10.2x ↘ 44: 9.2 ← 45: 9.8 ← 46: 10.5x ↘ 47: 10.3x → 48: 9.5 ← 49: 10.4x ↘ 50: 10.6x ↘ Serie 99.7 Total 505.3	60 Skott		51: 10.7x ↘ 52: 9.0 ← 53: 10.4x ↗ 54: 10.7x ↗ 55: 10.1 ← 56: 10.5x ↘ 57: 10.6x ↗ 58: 9.5 ← 59: 10.2x ↘ 60: 10.3x ↘ Serie 102.0 Total 607.3

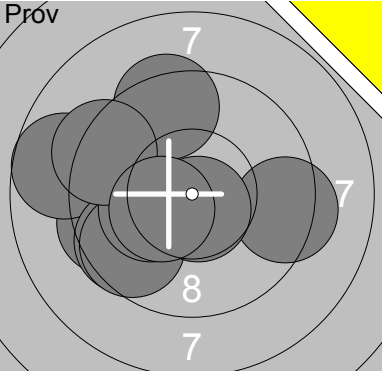
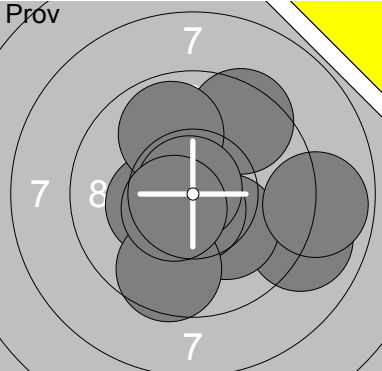
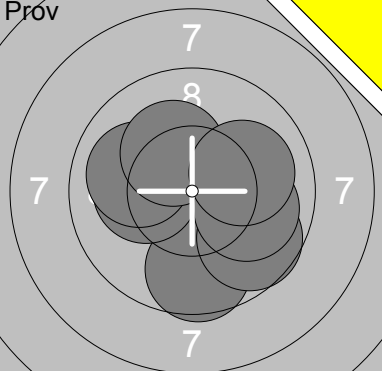
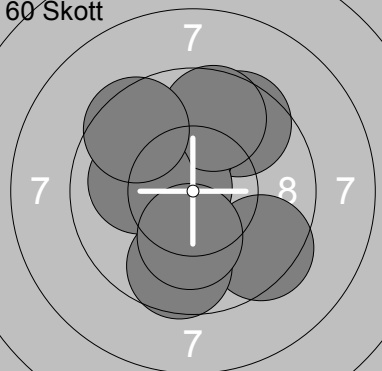
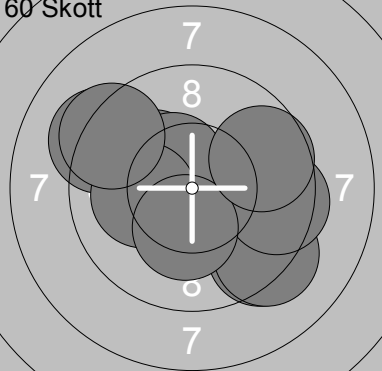
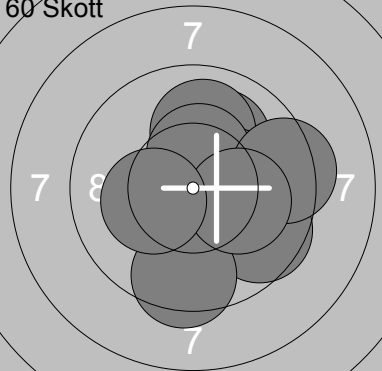
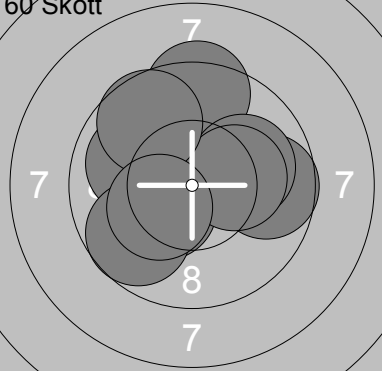
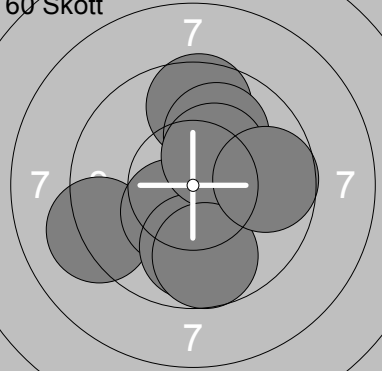
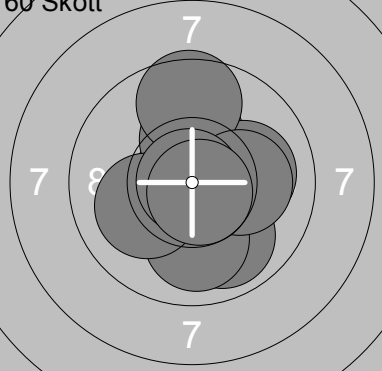
Skjuttag <b>3</b>	Tavla <b>24</b>	<b>Åke Stener</b>	
Vindeln	Aspås		Jä
18.03.2017	SM & JSM Luftgevär 2017	Ramselefors SKF	
Pröv 	1: 9.5 ← 2: 8.7 ← 3: 9.6 ↙ 4: 9.6 ↙ 5: 10.2x ← 6: 9.4 → 7: 9.4 ↑ 8: 9.3 ↗ 9: 10.7x ↓ 10: 10.4x ←	Pröv 	11: 9.5 ↗ 12: 9.0 → 13: 10.3x ← 14: 10.2x ↘ 15: 10.7x ↓ 16: 9.9 ↑ 17: 8.9 → 18: 9.6 ↓ 19: 10.8x ↗ 20: 10.5x ↙
	Serie 96.8 Total 0.0		Serie 99.4 Total 0.0
Pröv 	21: 9.6 ↓ 22: 9.7 ↘ 23: 10.2x ← 24: 10.0 ← 25: 10.2x ↗ 26: 10.0 → 27: 10.1 →	60 Skott 	1: 9.6 ↗ 2: 10.2x ↑ 3: 10.7x ← 4: 9.7 ↗ 5: 9.7 ↑ 6: 9.4 ↘ 7: 9.7 ↓ 8: 10.1 ← 9: 9.5 ↗ 10: 10.2x ↓
	Serie 69.8 Total 0.0		Serie 98.8 Total 98.8
60 Skott 	11: 10.2x ↗ 12: 10.4x ↗ 13: 9.3 ↘ 14: 9.2 ↗ 15: 9.3 ↘ 16: 10.1 ← 17: 9.5 → 18: 10.3x ↓ 19: 9.7 → 20: 9.3 ↗	60 Skott 	21: 9.6 → 22: 10.2x ↗ 23: 10.0 ↗ 24: 9.5 ↓ 25: 10.0 ↑ 26: 10.3x → 27: 10.4x ↑ 28: 9.4 → 29: 10.1 → 30: 10.2x ←
	Serie 97.3 Total 196.1		Serie 99.7 Total 295.8
60 Skott 	31: 10.3x ↑ 32: 10.3x ↙ 33: 10.0 ← 34: 9.7 → 35: 9.4 ↑ 36: 10.0 → 37: 10.2x → 38: 9.7 ↙ 39: 9.7 ↗ 40: 10.3x ↙	60 Skott 	41: 9.2 ← 42: 10.6x ↘ 43: 10.5x ↗ 44: 9.6 ↑ 45: 10.4x ↘ 46: 10.0 ↑ 47: 9.9 ↓ 48: 10.3x ↗ 49: 9.7 ↓ 50: 9.7 →
	Serie 99.6 Total 395.4		Serie 99.9 Total 495.3
60 Skott 	51: 9.9 ↓ 52: 10.0 ↓ 53: 10.8x ↗ 54: 10.2x ↑ 55: 10.1 → 56: 9.6 ↑ 57: 10.1 ← 58: 10.1 → 59: 10.9x ← 60: 10.7x ↓		
	Serie 102.4 Total 597.7		

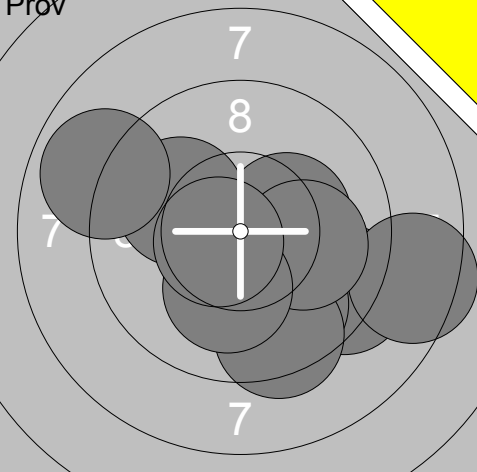
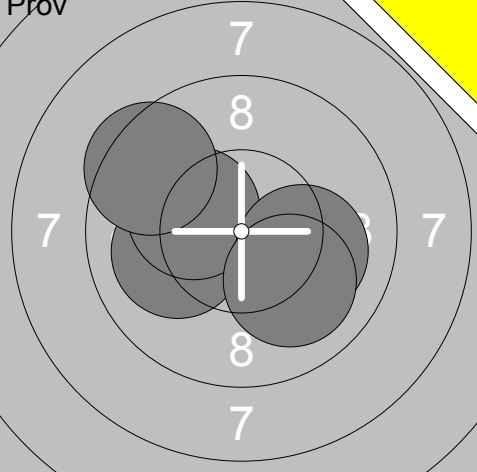
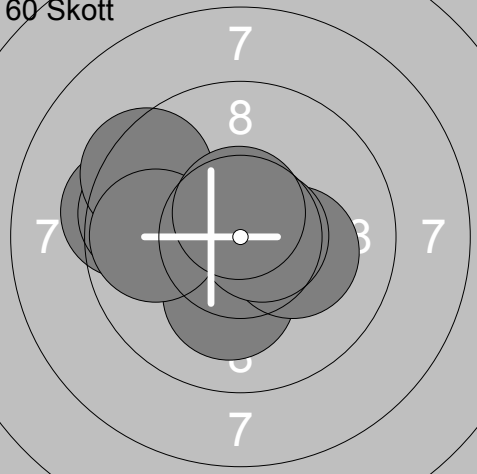
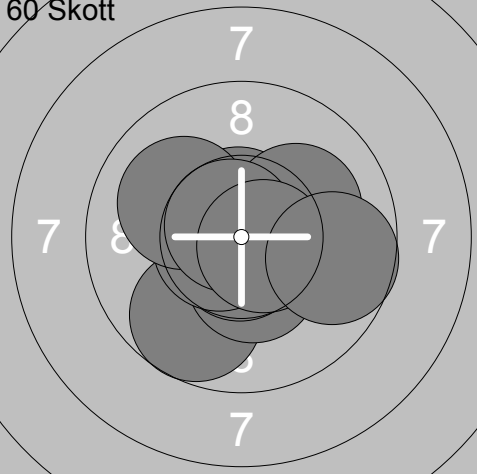
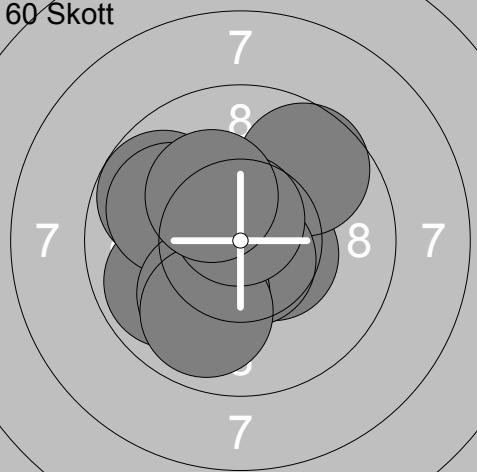
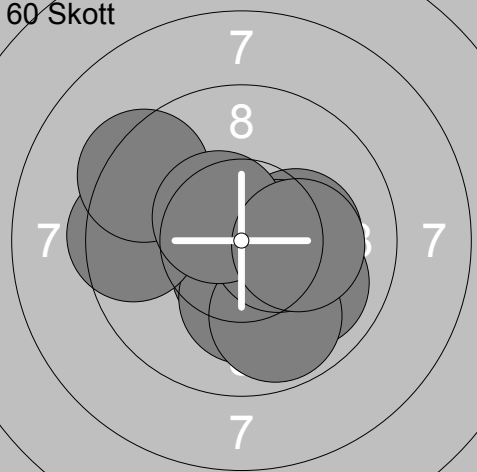
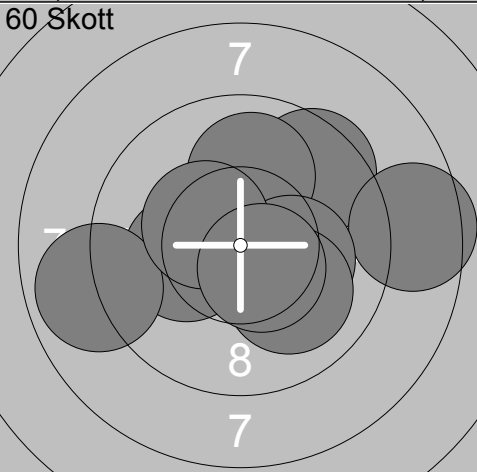
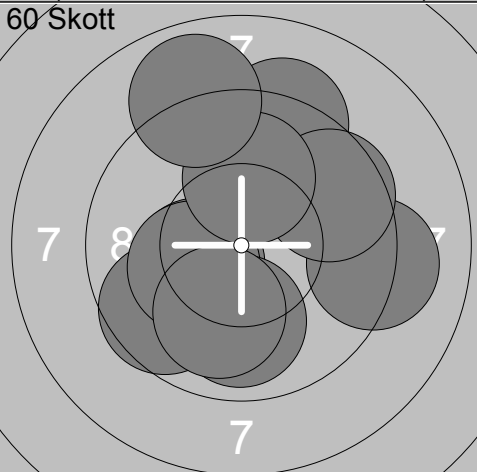
<b>Prov</b> 	1: 9.3 ↘ 2: 10.3x → 3: 8.5 → 4: 9.8 ↘ 5: 9.4 ↘ 6: 10.0 ↗ 7: 8.9 ↗ 8: 10.1 → 9: 10.1 ↓ 10: 10.6x ↙ <hr/> <b>Serie</b> 97.0 <b>Total</b> 0.0	<b>Prov</b> 	11: 10.0 ↙ 12: 10.3x ↖ 13: 9.5 ↗ 14: 10.1 → 15: 10.0 ↓ <hr/> <b>Serie</b> 49.9 <b>Total</b> 0.0
<b>60 Skott</b> 	1: 9.4 ↖ 2: 10.7x ↖ 3: 10.5x → 4: 10.2x ↓ 5: 10.2x → 6: 9.6 ↗ 7: 10.7x → 8: 9.4 ↗ 9: 9.8 ↖ 10: 10.6x ↑ <hr/> <b>Serie</b> 101.1 <b>Total</b> 101.1	<b>60 Skott</b> 	11: 9.7 ↓ 12: 10.4x ↓ 13: 10.7x ↓ 14: 10.6x ↑ 15: 10.1 ↗ 16: 10.6x ↖ 17: 10.0 ↗ 18: 10.7x ↗ 19: 10.6x → 20: 9.7 → <hr/> <b>Serie</b> 103.1 <b>Total</b> 204.2
<b>60 Skott</b> 	21: 9.8 ↗ 22: 9.9 ↖ 23: 10.5x ↘ 24: 9.7 ↗ 25: 10.7x ↘ 26: 9.9 ↗ 27: 10.1 ↘ 28: 9.9 ↘ 29: 10.7x ↑ 30: 10.2x ↗ <hr/> <b>Serie</b> 101.4 <b>Total</b> 305.6	<b>60 Skott</b> 	31: 10.6x ↓ 32: 10.2x ↓ 33: 10.0 ↘ 34: 9.5 ↖ 35: 10.2x → 36: 9.8 ↘ 37: 9.4 ↗ 38: 10.5x → 39: 10.5x ↗ 40: 10.2x → <hr/> <b>Serie</b> 100.9 <b>Total</b> 406.5
<b>60 Skott</b> 	41: 10.2x ↑ 42: 9.5 ↗ 43: 10.2x ↖ 44: 10.0 ↑ 45: 8.5 → 46: 8.9 ↖ 47: 10.2x → 48: 10.4x ↗ 49: 10.0 ↘ 50: 10.5x ↘ <hr/> <b>Serie</b> 98.4 <b>Total</b> 504.9	<b>60 Skott</b> 	51: 9.6 ↖ 52: 10.3x ↖ 53: 10.2x ↖ 54: 9.9 ↓ 55: 9.2 → 56: 10.0 ↓ 57: 9.2 ↗ 58: 9.6 ↗ 59: 10.0 ↑ 60: 8.9 ↑ <hr/> <b>Serie</b> 96.9 <b>Total</b> 601.8

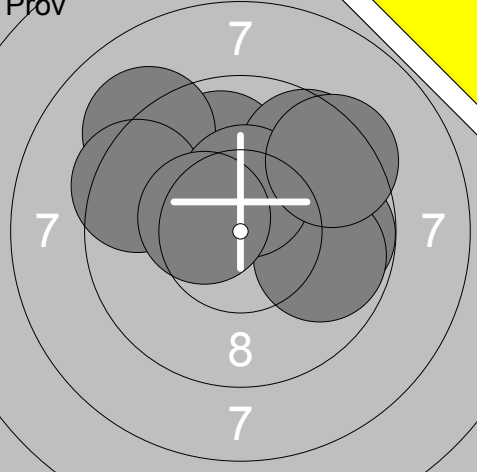
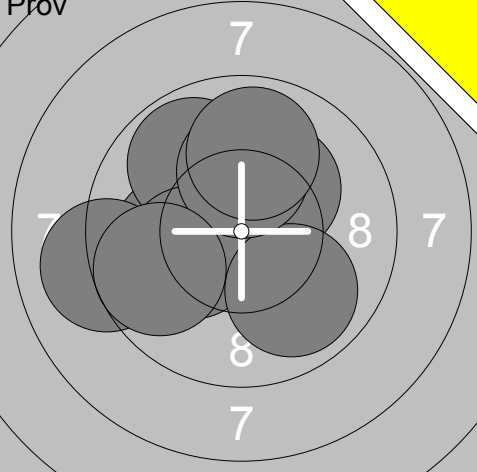
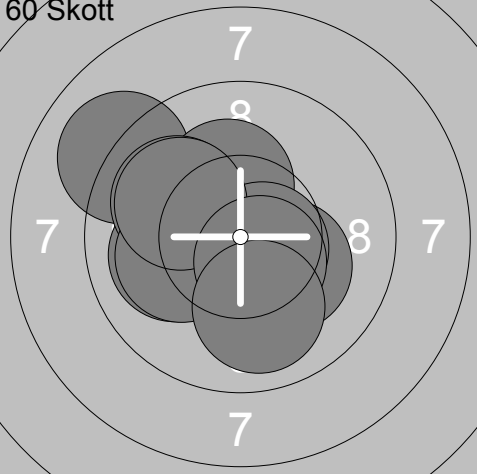
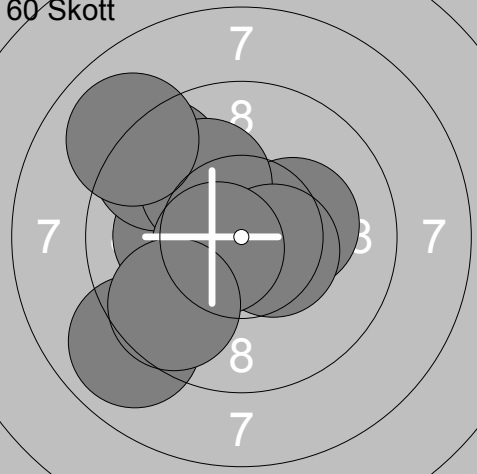
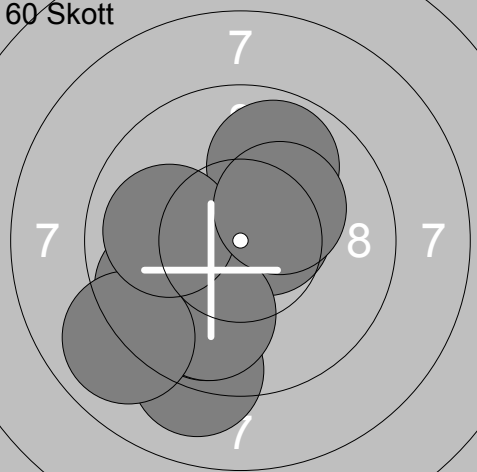
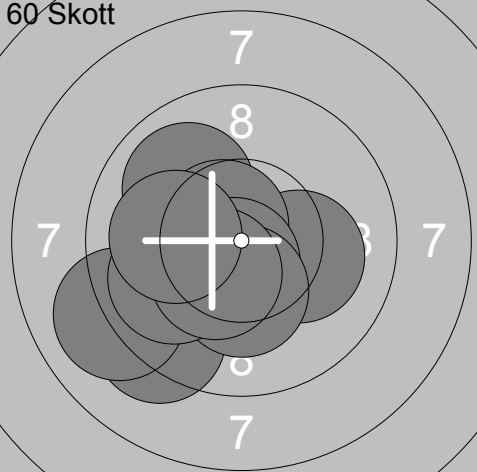
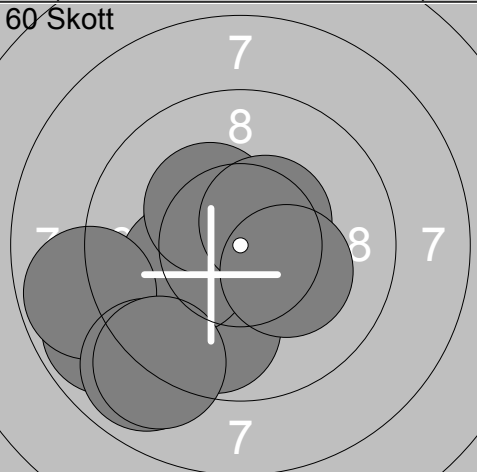
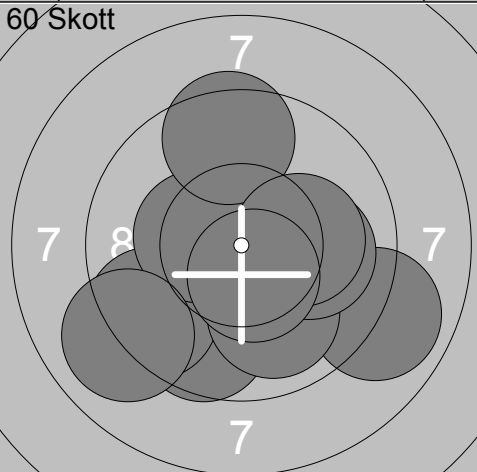

Skjutlag <b>3</b>	Tavla <b>26</b>	<b>Linus Eriksson</b>	
Vindeln	Delsbo-Bjuråker		Gä
18.03.2017	SM & JSM Luftgevär 2017	Ramselefors SKF	
<b>Pröv</b> 	1: 10.4x ↗ 2: 9.7 ↘ 3: 10.1 → 4: 10.0 ↗ 5: 10.0 ↓ 6: 9.3 → 7: 10.7x ↓ 8: 10.4x ↗ 9: 9.8 ↓ 10: 10.3x ↓ Serie 100.7 Total 0.0	<b>Pröv</b> 	11: 9.9 ↗ 12: 9.1 ← 13: 9.0 ↘ 14: 9.8 ↓ 15: 10.0 → 16: 9.1 ← 17: 10.2x ↓ 18: 10.1 ↓ 19: 10.0 ↗ 20: 10.0 ↖ Serie 97.2 Total 0.0
<b>Pröv</b> 	21: 10.3x ← 22: 9.6 ↓ 23: 8.1 ← 24: 10.0 → 25: 10.3x ← 26: 9.7 ↓ 27: 9.8 ↓ 28: 9.9 ← Serie 77.7 Total 0.0	<b>60 Skott</b> 	1: 9.6 ↘ 2: 9.6 ↑ 3: 9.2 → 4: 10.4x ↑ 5: 10.5x ← 6: 9.2 ← 7: 9.2 ↗ 8: 9.5 ↓ 9: 10.4x ↓ 10: 10.2x → Serie 97.8 Total 97.8
<b>60 Skott</b> 	11: 10.0 ↓ 12: 10.4x ↑ 13: 7.9 ↗ 14: 10.3x ↓ 15: 9.1 ↗ 16: 8.7 ← 17: 9.8 ← 18: 10.3x → 19: 9.0 ← 20: 9.7 ← Serie 95.2 Total 193.0	<b>60 Skott</b> 	21: 9.3 ↗ 22: 10.0 ← 23: 9.8 ↗ 24: 10.6x ↑ 25: 10.1 ↓ 26: 9.7 → 27: 10.3x ↓ 28: 10.3x ← 29: 10.1 ↗ 30: 10.2x → Serie 100.4 Total 293.4
<b>60 Skott</b> 	31: 10.0 ↘ 32: 10.2x → 33: 9.8 ↗ 34: 10.5x ← 35: 10.1 ↗ 36: 10.2x ← 37: 10.6x ← 38: 10.3x ↗ 39: 10.0 ↗ 40: 10.6x → Serie 102.3 Total 395.7	<b>60 Skott</b> 	41: 10.4x ↗ 42: 10.2x ← 43: 9.4 ← 44: 9.5 ↖ 45: 10.0 ↓ 46: 9.9 ← 47: 9.4 ← 48: 10.2x → 49: 10.2x → 50: 10.1 ↑ Serie 99.3 Total 495.0
<b>60 Skott</b> 	51: 10.5x ↗ 52: 10.2x → 53: 9.9 ↗ 54: 9.6 ↗ 55: 10.1 ↑ 56: 10.4x ↑ 57: 10.3x ← 58: 9.7 ← 59: 10.4x ↗ 60: 9.9 ↗ Serie 101.0 Total 596.0		

<b>Pröv</b> 	1: 10.3x ↑ 2: 9.9 ↑ 3: 9.1 ↗ 4: 9.8 → 5: 9.6 ↗ 6: 9.8 → 7: 9.4 ↗ 8: 10.4x ↑ 9: 10.4x ↖ 10: 9.4 ↗ <hr/> Serie 98.1 Total 0.0	<b>Pröv</b> 	11: 10.1 ← 12: 10.3x ↑ 13: 10.2x ↗ 14: 9.8 ↗ 15: 10.2x ← 16: 9.1 ← 17: 9.9 ↘ 18: 10.1 ↑ 19: 9.7 ← 20: 9.9 ↑ <hr/> Serie 99.3 Total 0.0
<b>60 Skott</b> 	1: 10.0 ← 2: 9.0 ↗ 3: 10.2x ↘ 4: 10.2x ↑ 5: 10.6x ↘ 6: 10.0 ↗ 7: 10.1 ← 8: 10.0 ↗ 9: 10.5x ↘ 10: 10.0 ↘ <hr/> Serie 100.6 Total 100.6	<b>60 Skott</b> 	11: 10.2x → 12: 10.1 ← 13: 9.5 ↗ 14: 10.1 ↗ 15: 0.0 16: 10.5x → 17: 9.0 ↗ 18: 8.9 ↘ 19: 10.6x ← 20: 9.7 ↘ <hr/> Serie 88.6 Total 189.2
<b>60 Skott</b> 	21: 10.1 ↖ 22: 9.7 ← 23: 9.1 ↘ 24: 9.9 ↘ 25: 10.6x → 26: 9.9 ↘ 27: 9.9 ↑ 28: 9.0 ← 29: 10.0 ← 30: 10.3x ↗ <hr/> Serie 98.5 Total 287.7	<b>60 Skott</b> 	31: 10.0 ↗ 32: 9.2 ↘ 33: 10.2x → 34: 9.0 ← 35: 10.6x ↗ 36: 10.6x ↘ 37: 10.3x ↘ 38: 9.9 ← 39: 10.4x ↘ 40: 10.1 ← <hr/> Serie 100.3 Total 388.0
<b>60 Skott</b> 	41: 10.4x ↗ 42: 9.8 ↘ 43: 8.8 ← 44: 10.1 ← 45: 8.8 ← 46: 8.9 ↘ 47: 10.3x ↗ 48: 9.0 ↘ 49: 10.5x ↗ 50: 10.2x ↘ <hr/> Serie 96.8 Total 484.8	<b>60 Skott</b> 	51: 9.6 ↘ 52: 9.4 ↘ 53: 10.4x ← 54: 9.5 ↑ 55: 8.9 → 56: 10.0 ↘ 57: 10.0 → 58: 10.2x → 59: 9.0 ↘ 60: 10.5x ↘ <hr/> Serie 97.5 Total 582.3

Skjutlag	Tavla	Albin Alexandersson	
3	28		
Vindeln	Gullabo		Sm
18.03.2017	SM & JSM Luftgevär 2017	Ramselefors SKF	
Pröv 	1: 10.1 ↗	Pröv 	11: 9.8 ←
	2: 10.7x ↑		12: 9.7 ↖
	3: 9.2 ↖		13: 9.3 ↗
	4: 8.8 →		14: 9.6 →
	5: 8.4 ↗		15: 9.7 ↑
	6: 10.0 ↑		16: 9.6 ↗
	7: 10.7x ↗		17: 10.3x ↓
	8: 9.0 →		18: 10.7x ↙
	9: 9.8 ↗		19: 10.3x ↑
	10: 10.0 →		20: 10.5x ↑
	Serie 96.7		Serie 99.5
	Total 0.0		Total 0.0
Pröv 	21: 10.3x ↖	60 Skott 	1: 10.3x ↑
			2: 10.6x ↓
			3: 10.1 ←
			4: 9.8 →
			5: 9.6 ↖
			6: 10.5x ↓
			7: 10.5x ←
			8: 9.5 ↗
			9: 9.7 ↓
			10: 10.4x →
	Serie 10.3		Serie 101.0
	Total 0.0		Total 101.0
60 Skott 	11: 10.8x ↘	60 Skott 	21: 9.5 ↗
	12: 10.4x ↓		22: 10.0 ←
	13: 10.4x ↑		23: 10.3x ↓
	14: 10.5x ↘		24: 9.2 →
	15: 10.0 ↓		25: 10.4x ↖
	16: 10.4x ↙		26: 8.9 →
	17: 10.7x ↓		27: 10.3x ↑
	18: 10.0 ↓		28: 10.5x ↑
	19: 10.6x →		29: 10.3x ↗
	20: 10.6x →		30: 9.3 ↗
	Serie 104.4		Serie 98.7
	Total 205.4		Total 304.1
60 Skott 	31: 10.9x ↑	60 Skott 	41: 9.8 ↖
	32: 10.3x ↗		42: 10.2x ↓
	33: 10.1 →		43: 10.5x ↖
	34: 10.2x ←		44: 10.9x ←
	35: 9.6 ↗		45: 10.8x ↓
	36: 10.4x ↓		46: 10.6x →
	37: 9.6 ↗		47: 10.3x ↘
	38: 10.2x →		48: 10.0 ↗
	39: 10.8x ↑		49: 10.4x ←
	40: 9.7 ←		50: 10.0 ↗
	Serie 101.8		Serie 103.5
	Total 405.9		Total 509.4
60 Skott 	51: 9.4 ↗		
	52: 10.6x ↗		
	53: 9.4 ↖		
	54: 10.2x ←		
	55: 9.3 ↗		
	56: 9.7 ↗		
	57: 9.8 ←		
	58: 10.3x ↓		
	59: 9.5 ←		
	60: 8.5 ↗		
	Serie 96.7		
	Total 606.1		

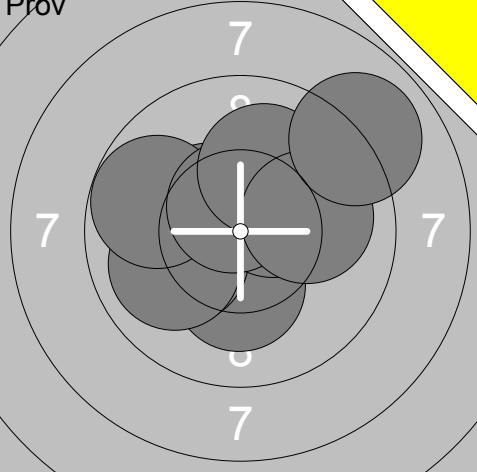
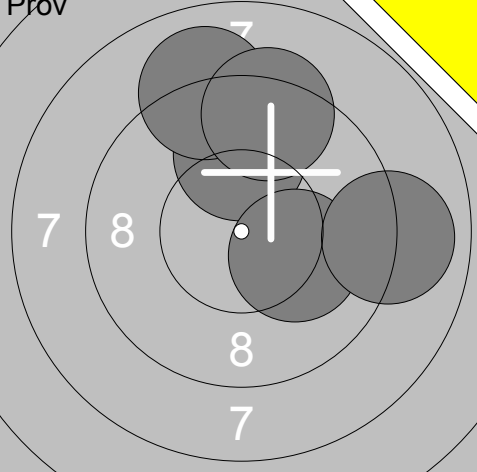
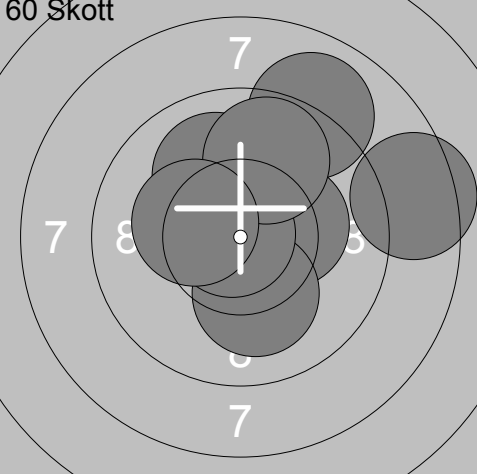
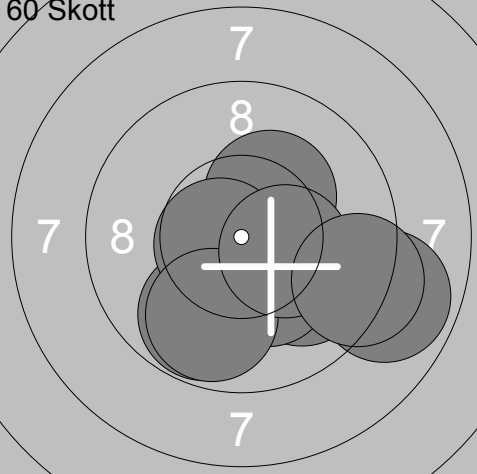
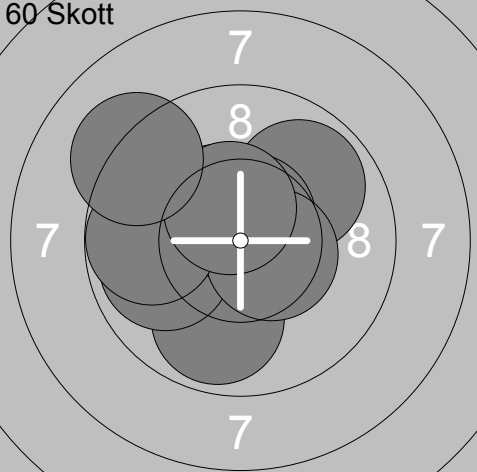
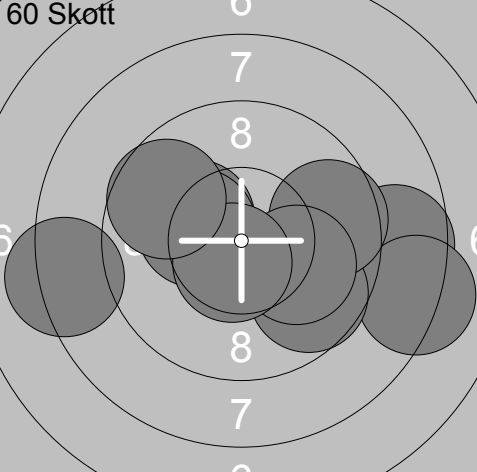
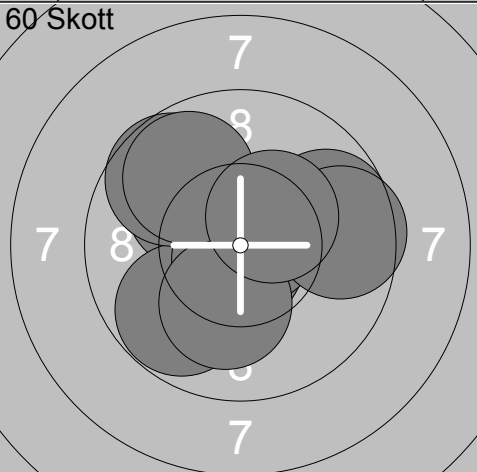
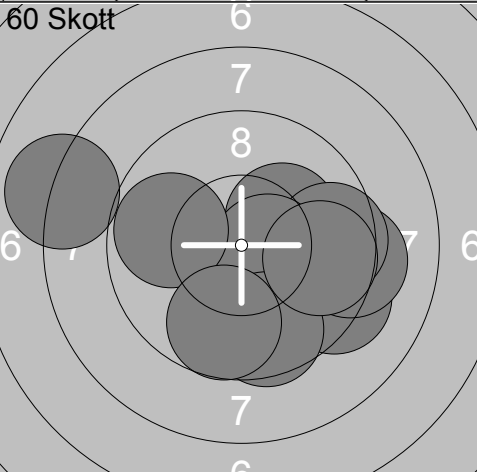
Pröv 	1: 10.2x ↓ 2: 10.4x ↗ 3: 10.1 ← 4: 10.0 ← 5: 10.4x → 6: 9.8 ↖ 7: 10.6x ↑ 8: 10.1 ↑ 9: 10.0 → 10: 9.0 ↘ <hr/> Serie 100.6 Total 0.0	Pröv 	11: 9.9 ↑ 12: 10.2x → 13: 9.0 ↑ 14: 9.3 ↑ 15: 9.0 → <hr/> Serie 47.4 Total 0.0
60 Skott 	1: 9.0 ↑ 2: 10.6x ↑ 3: 10.0 ↑ 4: 10.7x ↑ 5: 8.4 → 6: 10.3x → 7: 10.1 ↓ 8: 10.8x ↖ 9: 9.8 ↑ 10: 10.3x ↖ <hr/> Serie 100.0 Total 100.0	60 Skott 	11: 8.9 → 12: 9.8 ↓ 13: 10.0 ↓ 14: 10.3x ↓ 15: 10.3x ↗ 16: 10.3x ↓ 17: 10.7x ↖ 18: 9.8 ↓ 19: 10.3x → 20: 9.3 → <hr/> Serie 99.7 Total 199.7
60 Skott 	21: 9.9 ↓ 22: 10.0 ← 23: 9.9 ↗ 24: 9.9 ← 25: 10.6x ↑ 26: 10.5x ↗ 27: 10.5x ↘ 28: 9.8 ← 29: 10.5x ↗ 30: 9.2 ↗ <hr/> Serie 100.8 Total 300.5	60 Skott 	31: 10.2x ↖ 32: 8.6 → 33: 8.2 → 34: 8.2 ← 35: 9.7 ↓ 36: 10.3x ↖ 37: 9.6 → 38: 10.0 → 39: 10.6x ↓ 40: 9.7 ↗ <hr/> Serie 95.1 Total 395.6
60 Skott 	41: 10.1 ↗ 42: 9.8 ↖ 43: 9.7 ↗ 44: 10.8x ↓ 45: 10.7x → 46: 9.7 → 47: 10.1 ↓ 48: 9.6 → 49: 9.8 ↗ 50: 10.4x ↗ <hr/> Serie 100.7 Total 496.3	60 Skott 	51: 8.0 ↖ 52: 10.2x ↗ 53: 9.3 ↘ 54: 9.2 → 55: 9.6 → 56: 10.5x → 57: 9.6 ↓ 58: 9.8 ↖ 59: 9.7 ↓ 60: 9.7 → <hr/> Serie 95.6 Total 591.9

<p><b>Pröv</b></p>	<table border="1" style="width:100%; border-collapse: collapse;"> <tr><td>1:</td><td>9.3</td><td>↗</td></tr> <tr><td>2:</td><td>9.2</td><td>↖</td></tr> <tr><td>3:</td><td>9.3</td><td>↗</td></tr> <tr><td>4:</td><td>9.7</td><td>↗</td></tr> <tr><td>5:</td><td>8.9</td><td>↘</td></tr> <tr><td>6:</td><td>9.8</td><td>↗</td></tr> <tr><td>7:</td><td>9.4</td><td>↘</td></tr> <tr><td>8:</td><td>9.5</td><td>↘</td></tr> <tr><td>9:</td><td>8.1</td><td>↗</td></tr> <tr><td>10:</td><td>9.9</td><td>↗</td></tr> <tr><td colspan="2">Serie</td><td>93.1</td></tr> <tr><td colspan="2">Total</td><td>0.0</td></tr> </table>	1:	9.3	↗	2:	9.2	↖	3:	9.3	↗	4:	9.7	↗	5:	8.9	↘	6:	9.8	↗	7:	9.4	↘	8:	9.5	↘	9:	8.1	↗	10:	9.9	↗	Serie		93.1	Total		0.0	<p><b>Pröv</b></p>	<table border="1" style="width:100%; border-collapse: collapse;"> <tr><td>11:</td><td>9.7</td><td>↗</td></tr> <tr><td>12:</td><td>8.8</td><td>↖</td></tr> <tr><td>13:</td><td>9.6</td><td>↘</td></tr> <tr><td>14:</td><td>9.7</td><td>↖</td></tr> <tr><td>15:</td><td>9.9</td><td>↘</td></tr> <tr><td>16:</td><td>10.5x</td><td>↘</td></tr> <tr><td>17:</td><td>10.0</td><td>↘</td></tr> <tr><td>18:</td><td>10.7x</td><td>↘</td></tr> <tr><td>19:</td><td>10.8x</td><td>↗</td></tr> <tr><td colspan="2">Serie</td><td>89.7</td></tr> <tr><td colspan="2">Total</td><td>0.0</td></tr> </table>	11:	9.7	↗	12:	8.8	↖	13:	9.6	↘	14:	9.7	↖	15:	9.9	↘	16:	10.5x	↘	17:	10.0	↘	18:	10.7x	↘	19:	10.8x	↗	Serie		89.7	Total		0.0			
1:	9.3	↗																																																																									
2:	9.2	↖																																																																									
3:	9.3	↗																																																																									
4:	9.7	↗																																																																									
5:	8.9	↘																																																																									
6:	9.8	↗																																																																									
7:	9.4	↘																																																																									
8:	9.5	↘																																																																									
9:	8.1	↗																																																																									
10:	9.9	↗																																																																									
Serie		93.1																																																																									
Total		0.0																																																																									
11:	9.7	↗																																																																									
12:	8.8	↖																																																																									
13:	9.6	↘																																																																									
14:	9.7	↖																																																																									
15:	9.9	↘																																																																									
16:	10.5x	↘																																																																									
17:	10.0	↘																																																																									
18:	10.7x	↘																																																																									
19:	10.8x	↗																																																																									
Serie		89.7																																																																									
Total		0.0																																																																									
<p><b>60 Skott</b></p>	<table border="1" style="width:100%; border-collapse: collapse;"> <tr><td>1:</td><td>10.5x</td><td>↖</td></tr> <tr><td>2:</td><td>9.7</td><td>↖</td></tr> <tr><td>3:</td><td>10.4x</td><td>↖</td></tr> <tr><td>4:</td><td>9.9</td><td>↗</td></tr> <tr><td>5:</td><td>10.7x</td><td>↘</td></tr> <tr><td>6:</td><td>10.4x</td><td>↘</td></tr> <tr><td>7:</td><td>10.4x</td><td>↘</td></tr> <tr><td>8:</td><td>9.9</td><td>↗</td></tr> <tr><td>9:</td><td>9.9</td><td>↖</td></tr> <tr><td>10:</td><td>10.5x</td><td>↘</td></tr> <tr><td colspan="2">Serie</td><td>102.3</td></tr> <tr><td colspan="2">Total</td><td>102.3</td></tr> </table>	1:	10.5x	↖	2:	9.7	↖	3:	10.4x	↖	4:	9.9	↗	5:	10.7x	↘	6:	10.4x	↘	7:	10.4x	↘	8:	9.9	↗	9:	9.9	↖	10:	10.5x	↘	Serie		102.3	Total		102.3	<p><b>60 Skott</b></p>	<table border="1" style="width:100%; border-collapse: collapse;"> <tr><td>11:</td><td>10.2x</td><td>↗</td></tr> <tr><td>12:</td><td>10.0</td><td>↗</td></tr> <tr><td>13:</td><td>10.8x</td><td>↖</td></tr> <tr><td>14:</td><td>10.1</td><td>↖</td></tr> <tr><td>15:</td><td>7.5</td><td>↖</td></tr> <tr><td>16:</td><td>10.4x</td><td>↖</td></tr> <tr><td>17:</td><td>10.2x</td><td>↗</td></tr> <tr><td>18:</td><td>10.1</td><td>↗</td></tr> <tr><td>19:</td><td>9.4</td><td>↘</td></tr> <tr><td>20:</td><td>9.7</td><td>↘</td></tr> <tr><td colspan="2">Serie</td><td>98.4</td></tr> <tr><td colspan="2">Total</td><td>200.7</td></tr> </table>	11:	10.2x	↗	12:	10.0	↗	13:	10.8x	↖	14:	10.1	↖	15:	7.5	↖	16:	10.4x	↖	17:	10.2x	↗	18:	10.1	↗	19:	9.4	↘	20:	9.7	↘	Serie		98.4	Total		200.7
1:	10.5x	↖																																																																									
2:	9.7	↖																																																																									
3:	10.4x	↖																																																																									
4:	9.9	↗																																																																									
5:	10.7x	↘																																																																									
6:	10.4x	↘																																																																									
7:	10.4x	↘																																																																									
8:	9.9	↗																																																																									
9:	9.9	↖																																																																									
10:	10.5x	↘																																																																									
Serie		102.3																																																																									
Total		102.3																																																																									
11:	10.2x	↗																																																																									
12:	10.0	↗																																																																									
13:	10.8x	↖																																																																									
14:	10.1	↖																																																																									
15:	7.5	↖																																																																									
16:	10.4x	↖																																																																									
17:	10.2x	↗																																																																									
18:	10.1	↗																																																																									
19:	9.4	↘																																																																									
20:	9.7	↘																																																																									
Serie		98.4																																																																									
Total		200.7																																																																									
<p><b>60 Skott</b></p>	<table border="1" style="width:100%; border-collapse: collapse;"> <tr><td>21:</td><td>9.8</td><td>↘</td></tr> <tr><td>22:</td><td>9.6</td><td>↘</td></tr> <tr><td>23:</td><td>10.2x</td><td>↗</td></tr> <tr><td>24:</td><td>10.3x</td><td>↗</td></tr> <tr><td>25:</td><td>10.3x</td><td>↖</td></tr> <tr><td>26:</td><td>10.5x</td><td>↘</td></tr> <tr><td>27:</td><td>9.0</td><td>↘</td></tr> <tr><td>28:</td><td>10.7x</td><td>↘</td></tr> <tr><td>29:</td><td>10.4x</td><td>↖</td></tr> <tr><td>30:</td><td>9.2</td><td>↘</td></tr> <tr><td colspan="2">Serie</td><td>100.0</td></tr> <tr><td colspan="2">Total</td><td>300.7</td></tr> </table>	21:	9.8	↘	22:	9.6	↘	23:	10.2x	↗	24:	10.3x	↗	25:	10.3x	↖	26:	10.5x	↘	27:	9.0	↘	28:	10.7x	↘	29:	10.4x	↖	30:	9.2	↘	Serie		100.0	Total		300.7	<p><b>60 Skott</b></p>	<table border="1" style="width:100%; border-collapse: collapse;"> <tr><td>31:</td><td>10.0</td><td>↗</td></tr> <tr><td>32:</td><td>10.6x</td><td>↗</td></tr> <tr><td>33:</td><td>10.0</td><td>↖</td></tr> <tr><td>34:</td><td>9.7</td><td>↗</td></tr> <tr><td>35:</td><td>10.5x</td><td>↘</td></tr> <tr><td>36:</td><td>10.3x</td><td>↗</td></tr> <tr><td>37:</td><td>10.4x</td><td>↗</td></tr> <tr><td>38:</td><td>9.4</td><td>↖</td></tr> <tr><td>39:</td><td>9.7</td><td>↖</td></tr> <tr><td>40:</td><td>10.2x</td><td>↖</td></tr> <tr><td colspan="2">Serie</td><td>100.8</td></tr> <tr><td colspan="2">Total</td><td>401.5</td></tr> </table>	31:	10.0	↗	32:	10.6x	↗	33:	10.0	↖	34:	9.7	↗	35:	10.5x	↘	36:	10.3x	↗	37:	10.4x	↗	38:	9.4	↖	39:	9.7	↖	40:	10.2x	↖	Serie		100.8	Total		401.5
21:	9.8	↘																																																																									
22:	9.6	↘																																																																									
23:	10.2x	↗																																																																									
24:	10.3x	↗																																																																									
25:	10.3x	↖																																																																									
26:	10.5x	↘																																																																									
27:	9.0	↘																																																																									
28:	10.7x	↘																																																																									
29:	10.4x	↖																																																																									
30:	9.2	↘																																																																									
Serie		100.0																																																																									
Total		300.7																																																																									
31:	10.0	↗																																																																									
32:	10.6x	↗																																																																									
33:	10.0	↖																																																																									
34:	9.7	↗																																																																									
35:	10.5x	↘																																																																									
36:	10.3x	↗																																																																									
37:	10.4x	↗																																																																									
38:	9.4	↖																																																																									
39:	9.7	↖																																																																									
40:	10.2x	↖																																																																									
Serie		100.8																																																																									
Total		401.5																																																																									
<p><b>60 Skott</b></p>	<table border="1" style="width:100%; border-collapse: collapse;"> <tr><td>41:</td><td>10.0</td><td>↘</td></tr> <tr><td>42:</td><td>10.1</td><td>↘</td></tr> <tr><td>43:</td><td>10.7x</td><td>↗</td></tr> <tr><td>44:</td><td>10.3x</td><td>↗</td></tr> <tr><td>45:</td><td>10.9x</td><td>↗</td></tr> <tr><td>46:</td><td>9.8</td><td>↘</td></tr> <tr><td>47:</td><td>9.7</td><td>↗</td></tr> <tr><td>48:</td><td>10.6x</td><td>↗</td></tr> <tr><td>49:</td><td>10.5x</td><td>↗</td></tr> <tr><td>50:</td><td>10.2x</td><td>↗</td></tr> <tr><td colspan="2">Serie</td><td>102.8</td></tr> <tr><td colspan="2">Total</td><td>504.3</td></tr> </table>	41:	10.0	↘	42:	10.1	↘	43:	10.7x	↗	44:	10.3x	↗	45:	10.9x	↗	46:	9.8	↘	47:	9.7	↗	48:	10.6x	↗	49:	10.5x	↗	50:	10.2x	↗	Serie		102.8	Total		504.3	<p><b>60 Skott</b></p>	<table border="1" style="width:100%; border-collapse: collapse;"> <tr><td>51:</td><td>10.4x</td><td>↖</td></tr> <tr><td>52:</td><td>9.0</td><td>↖</td></tr> <tr><td>53:</td><td>10.5x</td><td>↗</td></tr> <tr><td>54:</td><td>9.5</td><td>↖</td></tr> <tr><td>55:</td><td>9.2</td><td>↗</td></tr> <tr><td>56:</td><td>9.9</td><td>↘</td></tr> <tr><td>57:</td><td>10.5x</td><td>↘</td></tr> <tr><td>58:</td><td>10.3x</td><td>↖</td></tr> <tr><td>59:</td><td>10.7x</td><td>↗</td></tr> <tr><td>60:</td><td>10.5x</td><td>↗</td></tr> <tr><td colspan="2">Serie</td><td>100.5</td></tr> <tr><td colspan="2">Total</td><td>604.8</td></tr> </table>	51:	10.4x	↖	52:	9.0	↖	53:	10.5x	↗	54:	9.5	↖	55:	9.2	↗	56:	9.9	↘	57:	10.5x	↘	58:	10.3x	↖	59:	10.7x	↗	60:	10.5x	↗	Serie		100.5	Total		604.8
41:	10.0	↘																																																																									
42:	10.1	↘																																																																									
43:	10.7x	↗																																																																									
44:	10.3x	↗																																																																									
45:	10.9x	↗																																																																									
46:	9.8	↘																																																																									
47:	9.7	↗																																																																									
48:	10.6x	↗																																																																									
49:	10.5x	↗																																																																									
50:	10.2x	↗																																																																									
Serie		102.8																																																																									
Total		504.3																																																																									
51:	10.4x	↖																																																																									
52:	9.0	↖																																																																									
53:	10.5x	↗																																																																									
54:	9.5	↖																																																																									
55:	9.2	↗																																																																									
56:	9.9	↘																																																																									
57:	10.5x	↘																																																																									
58:	10.3x	↖																																																																									
59:	10.7x	↗																																																																									
60:	10.5x	↗																																																																									
Serie		100.5																																																																									
Total		604.8																																																																									

Skjutlag	Tavla	Einar Nilsson	
3	31		
Vindeln	Björksta		Vm
18.03.2017	SM & JSM Luftgevär 2017	Ramselefors SKF	
<b>Pröv</b> 	1: 9.7 ↗ 2: 10.2x ↘ 3: 8.9 ← 4: 10.1 ↘ 5: 10.1 ↗ 6: 10.5x ↗ 7: 9.8 → 8: 10.0 ↗ 9: 9.0 ← 10: 8.0 ← Serie 96.3 Total 0.0	<b>Pröv</b> 	11: 10.5x ↗ 12: 10.5x ↗ 13: 10.0 ↗ 14: 10.5x ↘ 15: 9.3 ← Serie 50.8 Total 0.0
<b>60 Skott</b> 	1: 10.3x ↘ 2: 10.4x ↘ 3: 10.0 ↗ 4: 9.2 ← 5: 10.2x ← 6: 10.3x ← 7: 10.7x ↗ 8: 9.6 ↗ 9: 9.9 ↗ 10: 9.9 ↗ Serie 100.5 Total 100.5	<b>60 Skott</b> 	11: 10.2x ← 12: 10.1 ← 13: 10.4x ↘ 14: 8.0 ← 15: 10.4x ↘ 16: 10.4x ↗ 17: 10.1 ↗ 18: 10.6x ↗ 19: 10.5x ↗ 20: 10.2x ↘ Serie 100.9 Total 201.4
<b>60 Skott</b> 	21: 9.2 ↗ 22: 8.8 → 23: 10.3x ← 24: 9.8 → 25: 10.0 ↗ 26: 10.1 ↗ 27: 10.0 ← 28: 10.2x ↗ 29: 10.2x ↘ 30: 9.8 ↗ Serie 98.4 Total 299.8	<b>60 Skott</b> 	31: 9.9 ↗ 32: 10.2x ↗ 33: 10.1 → 34: 9.2 ← 35: 9.7 → 36: 10.4x ↗ 37: 10.6x ↗ 38: 9.6 ↘ 39: 10.6x → 40: 10.5x ↘ Serie 100.8 Total 400.6
<b>60 Skott</b> 	41: 9.5 ↘ 42: 10.4x → 43: 10.6x ↗ 44: 9.9 ↘ 45: 9.8 ← 46: 10.4x ← 47: 10.1 → 48: 10.4x → 49: 10.2x ↘ 50: 9.5 → Serie 100.8 Total 501.4	<b>60 Skott</b> 	51: 10.2x ↗ 52: 10.2x → 53: 10.2x → 54: 10.0 → 55: 9.1 ↗ 56: 10.5x ↘ 57: 10.7x ↗ 58: 10.7x ↘ 59: 10.7x ↘ 60: 9.6 ← Serie 101.9 Total 603.3

<p>Pröv</p>	<p>1: 9.3 ← 2: 9.1 ↙ 3: 10.4x ↓ 4: 8.8 → 5: 9.3 ↗ 6: 10.1 ← 7: 9.4 ↗ 8: 9.4 ← 9: 10.8x ← 10: 9.9 ←</p> <p>Serie 96.5 Total 0.0</p>	<p>Pröv</p>	<p>11: 8.5 → 12: 9.6 ↓ 13: 10.6x → 14: 8.5 → 15: 9.4 → 16: 10.1 ↗ 17: 10.7x →</p> <p>Serie 67.4 Total 0.0</p>
<p>60 Skott</p>	<p>1: 9.5 → 2: 9.7 ↓ 3: 10.5x → 4: 9.4 ↓ 5: 9.5 ↗ 6: 10.0 → 7: 9.2 → 8: 9.4 ↓ 9: 10.3x ↑ 10: 9.8 ↑</p> <p>Serie 97.3 Total 97.3</p>	<p>60 Skott</p>	<p>11: 9.8 ↓ 12: 10.0 ↗ 13: 10.3x → 14: 10.6x → 15: 10.5x → 16: 9.2 ↑ 17: 10.0 ↑ 18: 9.1 → 19: 8.3 ↙ 20: 8.1 ↘</p> <p>Serie 95.9 Total 193.2</p>
<p>60 Skott</p>	<p>21: 10.7x ↖ 22: 9.0 → 23: 10.2x ↙ 24: 10.5x → 25: 9.5 ← 26: 8.6 → 27: 8.9 ↗ 28: 9.9 ← 29: 10.5x ↓ 30: 10.0 ↑</p> <p>Serie 97.8 Total 291.0</p>	<p>60 Skott</p>	<p>31: 9.8 ↓ 32: 10.0 ↓ 33: 9.5 ↓ 34: 9.5 ↑ 35: 9.8 ↑ 36: 9.9 ← 37: 9.5 ↗ 38: 9.2 ↑ 39: 10.6x ↗ 40: 9.7 ↖</p> <p>Serie 97.5 Total 388.5</p>
<p>60 Skott</p>	<p>41: 8.7 ↖ 42: 9.4 ↙ 43: 8.3 ↘ 44: 9.0 ↗ 45: 10.4x ↑ 46: 10.5x ↑ 47: 9.7 ↓ 48: 9.9 → 49: 9.0 → 50: 8.9 ↑</p> <p>Serie 93.8 Total 482.3</p>	<p>60 Skott</p>	<p>51: 10.0 ↓ 52: 9.2 ↖ 53: 8.0 ← 54: 8.5 ↗ 55: 9.2 ↗ 56: 8.8 ↓ 57: 9.5 ↗ 58: 9.4 → 59: 9.9 → 60: 8.4 ↓</p> <p>Serie 90.9 Total 573.2</p>

<p><b>Prov</b></p>	<table style="width:100%; border-collapse: collapse;"> <tr><td>1:</td><td>10.2x</td><td>←</td></tr> <tr><td>2:</td><td>9.8</td><td>→</td></tr> <tr><td>3:</td><td>9.9</td><td>→</td></tr> <tr><td>4:</td><td>10.2x</td><td>↑</td></tr> <tr><td>5:</td><td>8.0</td><td>←</td></tr> <tr><td>6:</td><td>8.9</td><td>→</td></tr> <tr><td>7:</td><td>9.9</td><td>↓</td></tr> <tr><td>8:</td><td>8.9</td><td>↗</td></tr> <tr><td>9:</td><td>9.7</td><td>↓</td></tr> <tr><td>10:</td><td>9.2</td><td>←</td></tr> <tr><td colspan="2"><b>Serie</b></td><td style="text-align: right;"><b>94.7</b></td></tr> <tr><td colspan="2"><b>Total</b></td><td style="text-align: right;"><b>0.0</b></td></tr> </table>	1:	10.2x	←	2:	9.8	→	3:	9.9	→	4:	10.2x	↑	5:	8.0	←	6:	8.9	→	7:	9.9	↓	8:	8.9	↗	9:	9.7	↓	10:	9.2	←	<b>Serie</b>		<b>94.7</b>	<b>Total</b>		<b>0.0</b>	<p><b>Prov</b></p>	<table style="width:100%; border-collapse: collapse;"> <tr><td>11:</td><td>9.8</td><td>↗</td></tr> <tr><td>12:</td><td>8.5</td><td>←</td></tr> <tr><td>13:</td><td>9.3</td><td>↗</td></tr> <tr><td>14:</td><td>8.3</td><td>←</td></tr> <tr><td>15:</td><td>7.6</td><td>↗</td></tr> <tr><td>16:</td><td>9.5</td><td>→</td></tr> <tr><td>17:</td><td>9.3</td><td>↓</td></tr> <tr><td colspan="2"><b>Serie</b></td><td style="text-align: right;"><b>62.3</b></td></tr> <tr><td colspan="2"><b>Total</b></td><td style="text-align: right;"><b>0.0</b></td></tr> </table>	11:	9.8	↗	12:	8.5	←	13:	9.3	↗	14:	8.3	←	15:	7.6	↗	16:	9.5	→	17:	9.3	↓	<b>Serie</b>		<b>62.3</b>	<b>Total</b>		<b>0.0</b>									
1:	10.2x	←																																																																									
2:	9.8	→																																																																									
3:	9.9	→																																																																									
4:	10.2x	↑																																																																									
5:	8.0	←																																																																									
6:	8.9	→																																																																									
7:	9.9	↓																																																																									
8:	8.9	↗																																																																									
9:	9.7	↓																																																																									
10:	9.2	←																																																																									
<b>Serie</b>		<b>94.7</b>																																																																									
<b>Total</b>		<b>0.0</b>																																																																									
11:	9.8	↗																																																																									
12:	8.5	←																																																																									
13:	9.3	↗																																																																									
14:	8.3	←																																																																									
15:	7.6	↗																																																																									
16:	9.5	→																																																																									
17:	9.3	↓																																																																									
<b>Serie</b>		<b>62.3</b>																																																																									
<b>Total</b>		<b>0.0</b>																																																																									
<p><b>60 Skott</b></p>	<table style="width:100%; border-collapse: collapse;"> <tr><td>1:</td><td>7.8</td><td>→</td></tr> <tr><td>2:</td><td>9.8</td><td>←</td></tr> <tr><td>3:</td><td>9.5</td><td>↙</td></tr> <tr><td>4:</td><td>9.3</td><td>→</td></tr> <tr><td>5:</td><td>10.5x</td><td>↗</td></tr> <tr><td>6:</td><td>9.7</td><td>←</td></tr> <tr><td>7:</td><td>9.4</td><td>←</td></tr> <tr><td>8:</td><td>9.4</td><td>→</td></tr> <tr><td>9:</td><td>10.0</td><td>←</td></tr> <tr><td>10:</td><td>8.8</td><td>↙</td></tr> <tr><td colspan="2"><b>Serie</b></td><td style="text-align: right;"><b>94.2</b></td></tr> <tr><td colspan="2"><b>Total</b></td><td style="text-align: right;"><b>94.2</b></td></tr> </table>	1:	7.8	→	2:	9.8	←	3:	9.5	↙	4:	9.3	→	5:	10.5x	↗	6:	9.7	←	7:	9.4	←	8:	9.4	→	9:	10.0	←	10:	8.8	↙	<b>Serie</b>		<b>94.2</b>	<b>Total</b>		<b>94.2</b>	<p><b>60 Skott</b></p>	<table style="width:100%; border-collapse: collapse;"> <tr><td>11:</td><td>9.5</td><td>↗</td></tr> <tr><td>12:</td><td>8.2</td><td>←</td></tr> <tr><td>13:</td><td>6.9</td><td>←</td></tr> <tr><td>14:</td><td>6.4</td><td>←</td></tr> <tr><td>15:</td><td>7.9</td><td>←</td></tr> <tr><td>16:</td><td>8.9</td><td>←</td></tr> <tr><td>17:</td><td>9.2</td><td>→</td></tr> <tr><td>18:</td><td>8.6</td><td>←</td></tr> <tr><td>19:</td><td>10.4x</td><td>↙</td></tr> <tr><td>20:</td><td>9.8</td><td>→</td></tr> <tr><td colspan="2"><b>Serie</b></td><td style="text-align: right;"><b>85.8</b></td></tr> <tr><td colspan="2"><b>Total</b></td><td style="text-align: right;"><b>180.0</b></td></tr> </table>	11:	9.5	↗	12:	8.2	←	13:	6.9	←	14:	6.4	←	15:	7.9	←	16:	8.9	←	17:	9.2	→	18:	8.6	←	19:	10.4x	↙	20:	9.8	→	<b>Serie</b>		<b>85.8</b>	<b>Total</b>		<b>180.0</b>
1:	7.8	→																																																																									
2:	9.8	←																																																																									
3:	9.5	↙																																																																									
4:	9.3	→																																																																									
5:	10.5x	↗																																																																									
6:	9.7	←																																																																									
7:	9.4	←																																																																									
8:	9.4	→																																																																									
9:	10.0	←																																																																									
10:	8.8	↙																																																																									
<b>Serie</b>		<b>94.2</b>																																																																									
<b>Total</b>		<b>94.2</b>																																																																									
11:	9.5	↗																																																																									
12:	8.2	←																																																																									
13:	6.9	←																																																																									
14:	6.4	←																																																																									
15:	7.9	←																																																																									
16:	8.9	←																																																																									
17:	9.2	→																																																																									
18:	8.6	←																																																																									
19:	10.4x	↙																																																																									
20:	9.8	→																																																																									
<b>Serie</b>		<b>85.8</b>																																																																									
<b>Total</b>		<b>180.0</b>																																																																									
<p><b>60 Skott</b></p>	<table style="width:100%; border-collapse: collapse;"> <tr><td>21:</td><td>8.3</td><td>↙</td></tr> <tr><td>22:</td><td>8.0</td><td>→</td></tr> <tr><td>23:</td><td>9.5</td><td>↙</td></tr> <tr><td>24:</td><td>10.7x</td><td>←</td></tr> <tr><td>25:</td><td>8.9</td><td>→</td></tr> <tr><td>26:</td><td>8.9</td><td>↗</td></tr> <tr><td>27:</td><td>8.9</td><td>←</td></tr> <tr><td>28:</td><td>6.6</td><td>→</td></tr> <tr><td>29:</td><td>7.5</td><td>←</td></tr> <tr><td>30:</td><td>9.1</td><td>←</td></tr> <tr><td colspan="2"><b>Serie</b></td><td style="text-align: right;"><b>86.4</b></td></tr> <tr><td colspan="2"><b>Total</b></td><td style="text-align: right;"><b>266.4</b></td></tr> </table>	21:	8.3	↙	22:	8.0	→	23:	9.5	↙	24:	10.7x	←	25:	8.9	→	26:	8.9	↗	27:	8.9	←	28:	6.6	→	29:	7.5	←	30:	9.1	←	<b>Serie</b>		<b>86.4</b>	<b>Total</b>		<b>266.4</b>	<p><b>60 Skott</b></p>	<table style="width:100%; border-collapse: collapse;"> <tr><td>31:</td><td>10.1</td><td>↓</td></tr> <tr><td>32:</td><td>9.1</td><td>→</td></tr> <tr><td>33:</td><td>10.4x</td><td>↘</td></tr> <tr><td>34:</td><td>9.7</td><td>←</td></tr> <tr><td>35:</td><td>9.9</td><td>→</td></tr> <tr><td>36:</td><td>8.6</td><td>←</td></tr> <tr><td>37:</td><td>8.2</td><td>↗</td></tr> <tr><td>38:</td><td>10.3x</td><td>↑</td></tr> <tr><td>39:</td><td>8.8</td><td>←</td></tr> <tr><td>40:</td><td>8.7</td><td>←</td></tr> <tr><td colspan="2"><b>Serie</b></td><td style="text-align: right;"><b>93.8</b></td></tr> <tr><td colspan="2"><b>Total</b></td><td style="text-align: right;"><b>360.2</b></td></tr> </table>	31:	10.1	↓	32:	9.1	→	33:	10.4x	↘	34:	9.7	←	35:	9.9	→	36:	8.6	←	37:	8.2	↗	38:	10.3x	↑	39:	8.8	←	40:	8.7	←	<b>Serie</b>		<b>93.8</b>	<b>Total</b>		<b>360.2</b>
21:	8.3	↙																																																																									
22:	8.0	→																																																																									
23:	9.5	↙																																																																									
24:	10.7x	←																																																																									
25:	8.9	→																																																																									
26:	8.9	↗																																																																									
27:	8.9	←																																																																									
28:	6.6	→																																																																									
29:	7.5	←																																																																									
30:	9.1	←																																																																									
<b>Serie</b>		<b>86.4</b>																																																																									
<b>Total</b>		<b>266.4</b>																																																																									
31:	10.1	↓																																																																									
32:	9.1	→																																																																									
33:	10.4x	↘																																																																									
34:	9.7	←																																																																									
35:	9.9	→																																																																									
36:	8.6	←																																																																									
37:	8.2	↗																																																																									
38:	10.3x	↑																																																																									
39:	8.8	←																																																																									
40:	8.7	←																																																																									
<b>Serie</b>		<b>93.8</b>																																																																									
<b>Total</b>		<b>360.2</b>																																																																									
<p><b>60 Skott</b></p>	<table style="width:100%; border-collapse: collapse;"> <tr><td>41:</td><td>9.1</td><td>↘</td></tr> <tr><td>42:</td><td>7.9</td><td>→</td></tr> <tr><td>43:</td><td>7.9</td><td>←</td></tr> <tr><td>44:</td><td>8.9</td><td>↓</td></tr> <tr><td>45:</td><td>9.4</td><td>↙</td></tr> <tr><td>46:</td><td>10.2x</td><td>↖</td></tr> <tr><td>47:</td><td>10.1</td><td>↑</td></tr> <tr><td>48:</td><td>10.0</td><td>←</td></tr> <tr><td>49:</td><td>9.0</td><td>↗</td></tr> <tr><td>50:</td><td>7.0</td><td>←</td></tr> <tr><td colspan="2"><b>Serie</b></td><td style="text-align: right;"><b>89.5</b></td></tr> <tr><td colspan="2"><b>Total</b></td><td style="text-align: right;"><b>449.7</b></td></tr> </table>	41:	9.1	↘	42:	7.9	→	43:	7.9	←	44:	8.9	↓	45:	9.4	↙	46:	10.2x	↖	47:	10.1	↑	48:	10.0	←	49:	9.0	↗	50:	7.0	←	<b>Serie</b>		<b>89.5</b>	<b>Total</b>		<b>449.7</b>	<p><b>60 Skott</b></p>	<table style="width:100%; border-collapse: collapse;"> <tr><td>51:</td><td>8.5</td><td>←</td></tr> <tr><td>52:</td><td>10.3x</td><td>↗</td></tr> <tr><td>53:</td><td>9.6</td><td>←</td></tr> <tr><td>54:</td><td>9.7</td><td>↙</td></tr> <tr><td>55:</td><td>9.1</td><td>←</td></tr> <tr><td>56:</td><td>9.8</td><td>↙</td></tr> <tr><td>57:</td><td>8.6</td><td>→</td></tr> <tr><td>58:</td><td>10.0</td><td>↘</td></tr> <tr><td>59:</td><td>9.8</td><td>←</td></tr> <tr><td>60:</td><td>7.8</td><td>↖</td></tr> <tr><td colspan="2"><b>Serie</b></td><td style="text-align: right;"><b>93.2</b></td></tr> <tr><td colspan="2"><b>Total</b></td><td style="text-align: right;"><b>542.9</b></td></tr> </table>	51:	8.5	←	52:	10.3x	↗	53:	9.6	←	54:	9.7	↙	55:	9.1	←	56:	9.8	↙	57:	8.6	→	58:	10.0	↘	59:	9.8	←	60:	7.8	↖	<b>Serie</b>		<b>93.2</b>	<b>Total</b>		<b>542.9</b>
41:	9.1	↘																																																																									
42:	7.9	→																																																																									
43:	7.9	←																																																																									
44:	8.9	↓																																																																									
45:	9.4	↙																																																																									
46:	10.2x	↖																																																																									
47:	10.1	↑																																																																									
48:	10.0	←																																																																									
49:	9.0	↗																																																																									
50:	7.0	←																																																																									
<b>Serie</b>		<b>89.5</b>																																																																									
<b>Total</b>		<b>449.7</b>																																																																									
51:	8.5	←																																																																									
52:	10.3x	↗																																																																									
53:	9.6	←																																																																									
54:	9.7	↙																																																																									
55:	9.1	←																																																																									
56:	9.8	↙																																																																									
57:	8.6	→																																																																									
58:	10.0	↘																																																																									
59:	9.8	←																																																																									
60:	7.8	↖																																																																									
<b>Serie</b>		<b>93.2</b>																																																																									
<b>Total</b>		<b>542.9</b>																																																																									

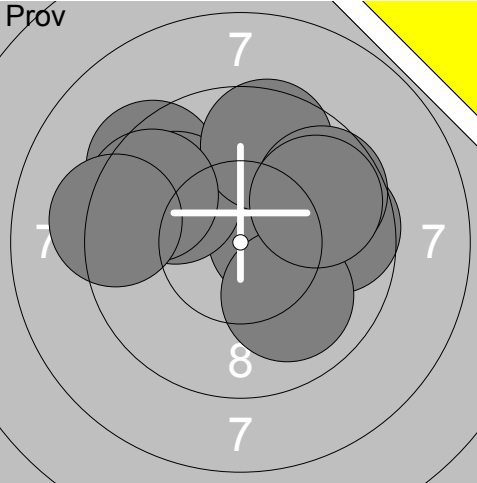
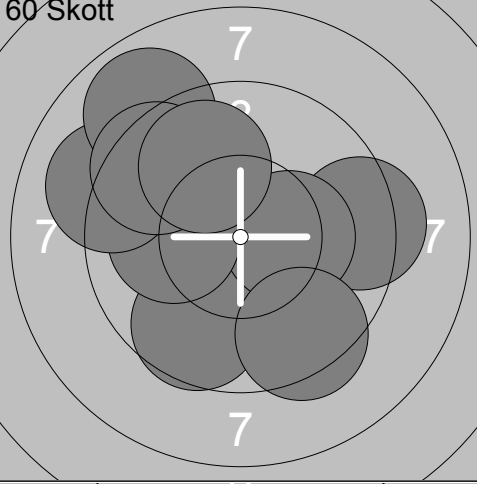
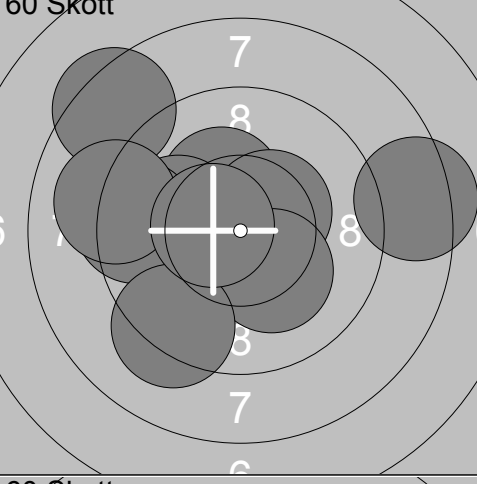
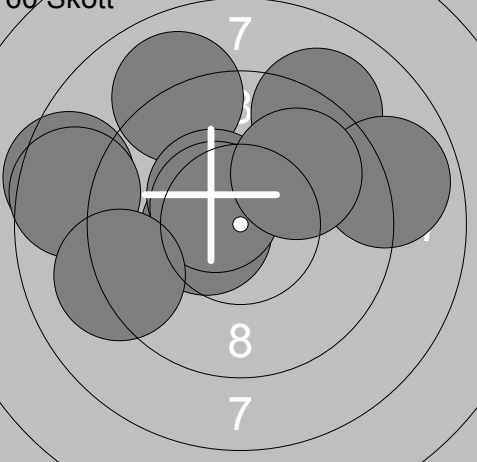

Skjuttag	Tavla	Jonas Olofsson	
3	34		
Vindeln	Aspås		Jä
18.03.2017	SM & JSM Luftgevär 2017	Ramselefors SKF	
Pröv		1: 10.5x → 2: 9.7 → 3: 10.0 ↘ 4: 9.4 ↗ 5: 9.9 ↗ 6: 9.6 ↗ 7: 9.6 ↗ 8: 9.7 ↗ 9: 9.8 → 10: 9.2 ←	Pröv
		Serie 97.4	
		Total 0.0	
			11: 10.7x → 12: 10.0 ← 13: 10.4x → 14: 10.7x ← 15: 9.9 ←
			Serie 51.7
			Total 0.0
60 Skott		1: 9.3 → 2: 10.0 ↗ 3: 9.6 ↘ 4: 10.3x → 5: 10.1 ← 6: 9.1 ↗ 7: 9.4 ↘ 8: 8.9 ↗ 9: 9.5 ↗ 10: 9.9 ↗	60 Skott
		Serie 96.1	
		Total 96.1	
			11: 9.7 → 12: 9.8 ↗ 13: 9.0 ↗ 14: 10.3x → 15: 10.2x ↘ 16: 10.1 → 17: 9.3 → 18: 9.4 ↗ 19: 8.0 ↑ 20: 9.4 ↗
			Serie 95.2
			Total 191.3
60 Skott		21: 10.3x ↗ 22: 8.3 → 23: 10.0 ← 24: 9.4 ← 25: 8.4 ↗ 26: 10.4x → 27: 10.2x ↘ 28: 9.2 ↘ 29: 9.1 ← 30: 10.5x ←	60 Skott
		Serie 95.8	
		Total 287.1	
			31: 10.2x → 32: 9.3 ↗ 33: 10.3x ← 34: 9.5 → 35: 10.5x ← 36: 9.2 ← 37: 9.7 → 38: 9.9 ↗ 39: 7.8 → 40: 10.1 ←
			Serie 96.5
			Total 383.6
60 Skott		41: 10.5x ← 42: 9.0 ↗ 43: 9.1 ↗ 44: 10.4x ↗ 45: 8.9 → 46: 8.5 ← 47: 10.5x ↗ 48: 8.6 ← 49: 9.2 ← 50: 9.9 ↗	60 Skott
		Serie 94.6	
		Total 478.2	
			51: 9.3 ↑ 52: 10.3x ↑ 53: 10.0 ↑ 54: 9.7 ↘ 55: 9.8 ↘ 56: 9.0 ← 57: 9.9 ↘ 58: 9.1 ↗ 59: 10.0 ← 60: 9.5 ↘
			Serie 96.6
			Total 574.8

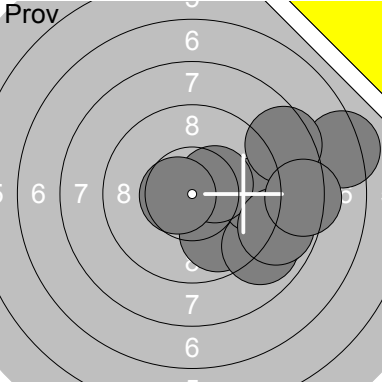
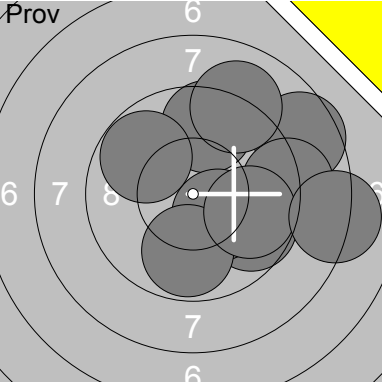
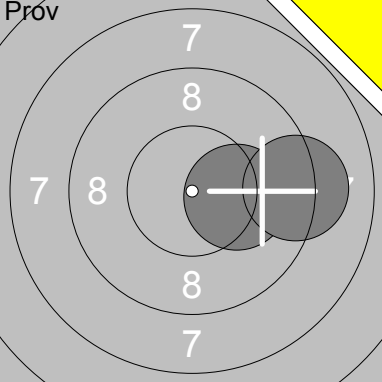
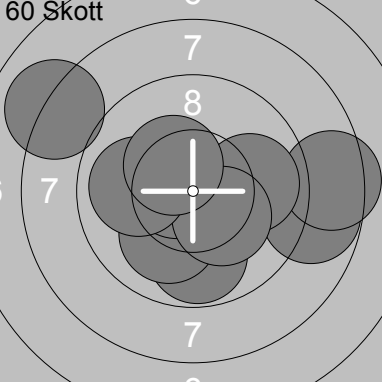
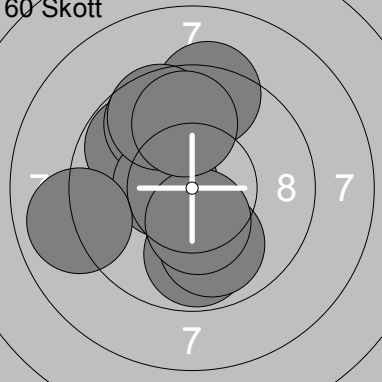
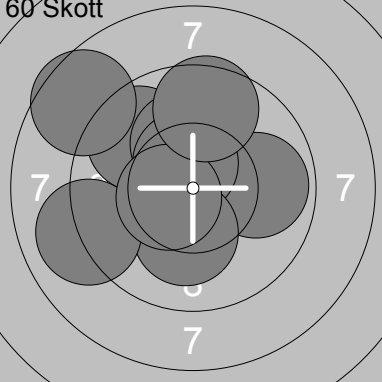
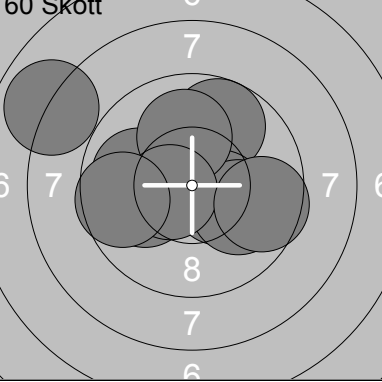
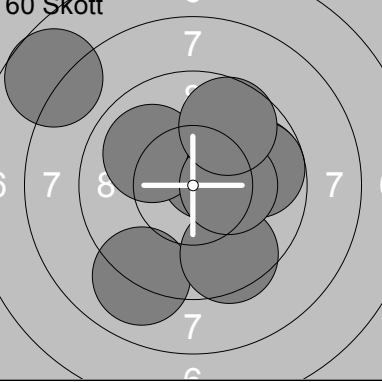
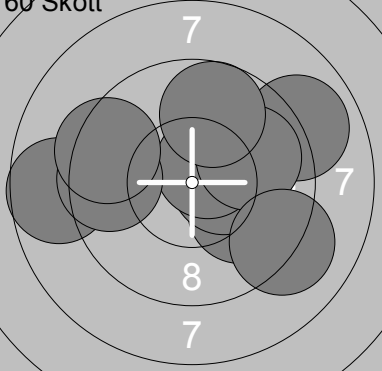
Skjutlag	Tavla	Casper Fredriksson	
3	35		
Vindeln	Ramselefors		Vb
18.03.2017	SM & JSM Luftgevär 2017	Ramselefors SKF	
	1: 8.9 → 2: 9.8 ↓ 3: 8.9 ↓ 4: 9.4 → 5: 7.3 → 6: 10.4x → 7: 8.5 → 8: 10.6x ← 9: 8.8 → 10: 8.3 → Serie 90.9 Total 0.0		11: 9.7 → 12: 9.6 ↑ 13: 10.3x ↓ 14: 8.6 → 15: 9.8 ↗ 16: 9.1 → 17: 9.8 ↓ 18: 9.1 ↑ 19: 9.8 → 20: 8.1 → Serie 93.9 Total 0.0
	21: 10.2x → 22: 9.2 → Serie 19.4 Total 0.0		1: 8.8 → 2: 9.8 ↓ 3: 8.4 → 4: 9.9 → 5: 10.1 ↓ 6: 8.0 ↗ 7: 10.7x ← 8: 10.3x ↓ 9: 10.0 ← 10: 10.4x ↗ Serie 96.4 Total 96.4
	11: 9.8 ↓ 12: 9.9 ↓ 13: 9.8 ↗ 14: 9.3 ↑ 15: 9.7 ↗ 16: 10.5x ← 17: 9.0 ← 18: 10.4x ↓ 19: 9.6 ↗ 20: 9.9 ↑ Serie 97.9 Total 194.3		21: 9.7 ↗ 22: 10.8x → 23: 10.2x ↑ 24: 8.6 ↗ 25: 9.9 → 26: 10.5x ↑ 27: 10.2x ↓ 28: 9.0 ← 29: 10.5x ← 30: 9.6 ↑ Serie 99.0 Total 293.3
	31: 9.7 ↑ 32: 7.9 ← 33: 10.4x → 34: 10.0 ← 35: 9.9 ← 36: 10.0 → 37: 10.0 ↑ 38: 10.5x ← 39: 9.6 ← 40: 9.6 → Serie 97.6 Total 390.9		41: 10.6x ↗ 42: 10.0 ↗ 43: 9.8 → 44: 9.0 ↓ 45: 9.5 ↓ 46: 7.7 ↗ 47: 10.1 → 48: 9.8 → 49: 10.3x → 50: 9.7 ↗ Serie 96.5 Total 487.4
	51: 10.0 → 52: 10.4x → 53: 10.6x ↗ 54: 8.9 → 55: 8.7 ← 56: 9.5 ← 57: 9.9 → 58: 9.1 ↓ 59: 9.7 ↑ 60: 9.4 ← Serie 96.2 Total 583.6		

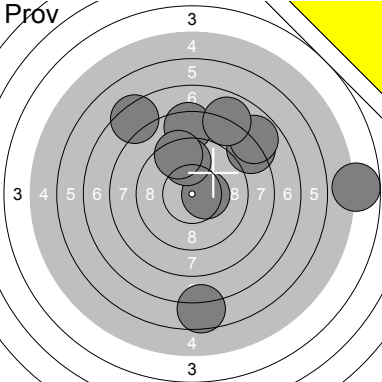
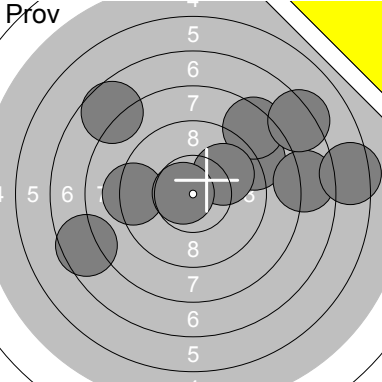
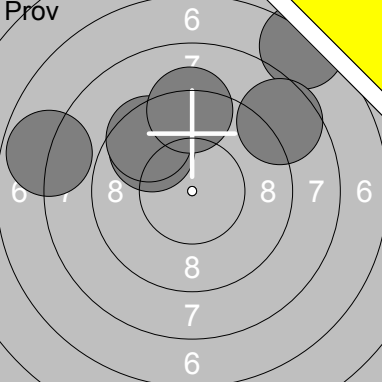
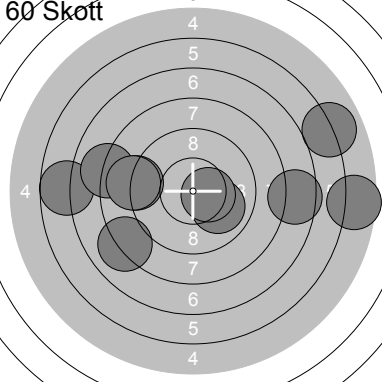
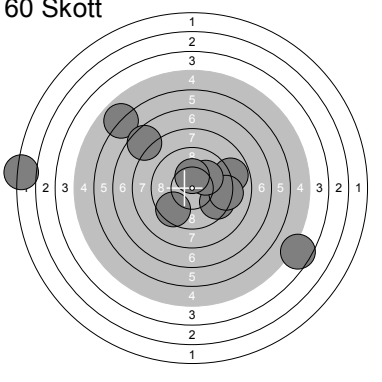
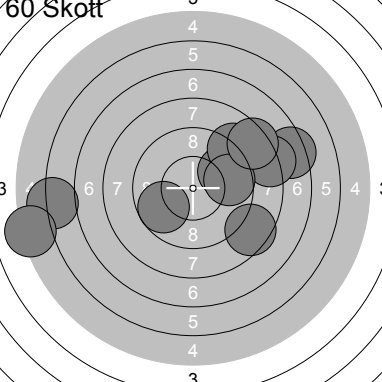
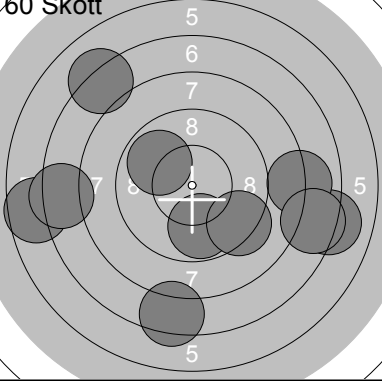
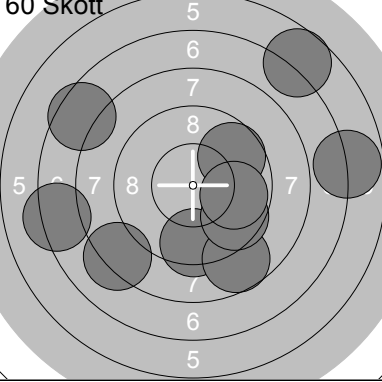
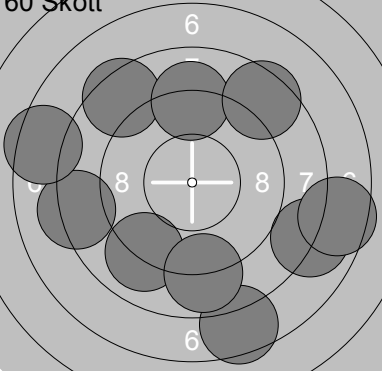
Skjutlag <b>3</b>	Tavla <b>36</b>	<b>William Wallin</b>	
Vindeln	Aspås		Jä
18.03.2017	SM & JSM Luftgevär 2017	Ramselefors SKF	
<b>Pröv</b> 	1: 8.2 ↗ 2: 6.6 ↓ 3: 10.4x → 4: 7.8 ↗ 5: 8.4 ↑ 6: 7.9 ↗ 7: 9.7 ↑ 8: 7.4 ↗ 9: 4.7 → 10: 9.4 ↑ Serie 80.5 Total 0.0	<b>Pröv</b> 	11: 7.7 ↖ 12: 8.9 ↗ 13: 7.7 → 14: 8.4 ↗ 15: 7.3 ↗ 16: 7.6 ↖ 17: 9.9 ↗ 18: 6.4 → 19: 9.2 ↖ 20: 10.7x ↖ Serie 83.8 Total 0.0
<b>Pröv</b> 	21: 7.1 ↗ 22: 7.9 ↖ 23: 9.7 ↗ 24: 9.5 ↗ 25: 8.6 ↗ 26: 9.3 ↑ Serie 52.1 Total 0.0	<b>60 Skott</b> 	1: 6.7 ↖ 2: 10.0 ↘ 3: 8.0 ↖ 4: 7.5 → 5: 5.6 → 6: 9.0 ↖ 7: 10.4x → 8: 6.0 ↗ 9: 8.1 ↖ 10: 8.9 ↖ Serie 80.2 Total 80.2
<b>60 Skott</b> 	11: 9.5 → 12: 2.1 ↖ 13: 5.9 ↗ 14: 9.5 ↘ 15: 4.6 ↘ 16: 8.8 → 17: 9.2 → 18: 7.6 ↗ 19: 10.1 ↗ 20: 10.3x ↑ Serie 77.6 Total 157.8	<b>60 Skott</b> 	21: 7.4 → 22: 8.1 → 23: 6.1 ↖ 24: 9.7 ↖ 25: 8.5 ↘ 26: 9.8 ↗ 27: 9.0 ↗ 28: 9.7 → 29: 5.2 ↖ 30: 8.4 ↗ Serie 81.9 Total 239.7
<b>60 Skott</b> 	31: 6.6 ↖ 32: 7.4 ↓ 33: 7.1 → 34: 8.0 → 35: 9.8 ↓ 36: 7.5 → 37: 7.4 ↖ 38: 9.3 ↓ 39: 7.1 ↗ 40: 9.9 ↗ Serie 80.1 Total 319.8	<b>60 Skott</b> 	41: 9.4 ↓ 42: 9.7 ↗ 43: 6.7 ↗ 44: 8.7 ↘ 45: 7.2 ↖ 46: 8.2 ↖ 47: 7.5 ↖ 48: 6.8 → 49: 9.6 ↘ 50: 9.8 → Serie 83.6 Total 403.4
<b>60 Skott</b> 	51: 8.4 ↗ 52: 8.0 → 53: 7.5 → 54: 9.1 ↑ 55: 8.2 ↖ 56: 7.5 ↓ 57: 8.5 ↗ 58: 9.0 ↘ 59: 8.9 ↓ 60: 7.4 ↖ Serie 82.5 Total 485.9		

<p>Prov</p>	<p>1: 9.7 ← 2: 9.7 → 3: 9.0 ↗ 4: 8.5 ↗ 5: 7.1 ↗ 6: 9.7 ↗ 7: 9.7 ↗ 8: 10.8x ↑ 9: 10.0 ↑ 10: 10.5x ↖</p> <p>Serie 94.7 Total 0.0</p>	<p>Prov</p>	<p>11: 9.4 ← 12: 9.9 ↗ 13: 9.7 ↗ 14: 8.6 ↗ 15: 10.3x ↓</p> <p>Serie 47.9 Total 0.0</p>
<p>60 Skott</p>	<p>1: 10.4x ← 2: 9.3 ← 3: 10.9x ← 4: 9.5 ↗ 5: 9.8 ↗ 6: 10.1 ↗ 7: 9.9 ← 8: 9.6 ↑ 9: 10.5x ↑ 10: 10.2x ↖</p> <p>Serie 100.2 Total 100.2</p>	<p>60 Skott</p>	<p>11: 10.9x ← 12: 10.7x ← 13: 10.5x ↓ 14: 10.8x ↗ 15: 9.4 → 16: 9.4 → 17: 10.6x ← 18: 10.5x ↓ 19: 10.1 ↓ 20: 10.4x ↓</p> <p>Serie 103.3 Total 203.5</p>
<p>60 Skott</p>	<p>21: 10.3x ↑ 22: 10.3x → 23: 9.7 ← 24: 8.5 ← 25: 10.1 ↓ 26: 10.3x ↓ 27: 10.1 → 28: 9.5 ↑ 29: 10.4x → 30: 9.7 ↖</p> <p>Serie 98.9 Total 302.4</p>	<p>60 Skott</p>	<p>31: 9.4 ← 32: 9.9 ↓ 33: 9.8 ↓ 34: 10.3x → 35: 10.2x ↗ 36: 9.2 ↑ 37: 9.8 → 38: 10.3x ↑ 39: 10.0 → 40: 9.7 ↑</p> <p>Serie 98.6 Total 401.0</p>
<p>60 Skott</p>	<p>41: 10.1 ↗ 42: 9.8 ↑ 43: 10.4x ↗ 44: 9.2 → 45: 9.3 ↑ 46: 10.2x ↖ 47: 10.7x ↓ 48: 10.3x → 49: 10.1 ↑ 50: 10.6x →</p> <p>Serie 100.7 Total 501.7</p>	<p>60 Skott</p>	<p>51: 10.0 ↓ 52: 10.5x → 53: 10.3x ← 54: 9.9 ↗ 55: 9.9 ← 56: 10.2x ↗ 57: 10.4x ↖ 58: 9.0 ↓ 59: 9.1 ← 60: 10.0 ↖</p> <p>Serie 99.3 Total 601.0</p>