

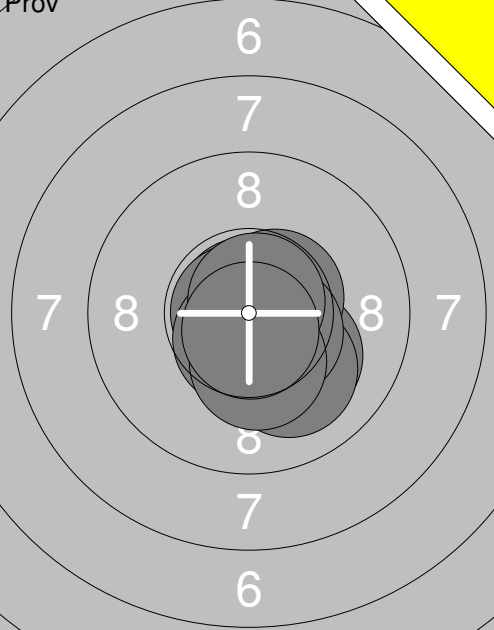



<p>Prov</p>	<p>1: 10.9x↘ 2: 10.4x➤ 3: 10.7x↘ 4: 10.5x➤ 5: 10.0 ↓ 6: 10.3x↘ 8: 10.7x↗ 9: 10.8x↘ 10: 10.5x↗</p> <p>Serie 94.8 Total 0.0</p>	<p>Prov</p>	<p>11: 10.8x↘ 12: 10.8x➤ 13: 10.5x↗</p> <p>Serie 32.1 Total 0.0</p>
<p>60 Skott</p>	<p>1: 10.5x↘ 2: 10.7x↘ 3: 10.5x↘ 4: 10.6x↘ 5: 10.3x↘ 6: 10.9x↗ 7: 10.6x↘ 8: 10.2x➤ 9: 10.6x↘ 10: 10.4x↘</p> <p>Serie 105.3 Total 105.3</p>	<p>60 Skott</p>	<p>11: 10.6x↘ 12: 10.3x↘ 13: 10.2x↘ 14: 10.3x↘ 15: 10.5x➤ 16: 10.8x➤ 17: 10.3x↘ 18: 10.5x↘ 19: 10.6x↗ 20: 10.9x↗</p> <p>Serie 105.0 Total 210.3</p>
<p>60 Skott</p>	<p>21: 10.3x➤ 22: 10.3x↘ 23: 10.4x↘ 24: 10.6x➤ 25: 10.3x↗ 26: 10.5x↘ 27: 10.4x↘ 28: 10.3x↘ 29: 10.4x↘ 30: 10.7x↗</p> <p>Serie 104.2 Total 314.5</p>	<p>60 Skott</p>	<p>31: 10.6x↗ 32: 10.7x↘ 33: 10.7x↗ 34: 10.7x↘ 35: 10.2x↗ 36: 10.7x➤ 37: 10.1 ↗ 38: 10.5x➤ 39: 10.7x↘ 40: 10.6x↘</p> <p>Serie 105.5 Total 420.0</p>

<p>Prov</p> 	<p>1: 10.1 ↘ 2: 10.1 ↘ 3: 10.5x ↗ 4: 10.9x ↗ 5: 10.8x ← 6: 10.6x ↘ 7: 10.5x ↘ 8: 10.3x ↘ 9: 10.8x ↗ 10: 10.7x ↘</p> <p>Serie 105.3 Total 0.0</p>	<p>Prov</p> 	<p>11: 10.5x ↘ 12: 10.7x ↗ 13: 10.6x ↗ 14: 10.7x ↗</p> <p>Serie 42.5 Total 0.0</p>
<p>60 Skott</p> 	<p>1: 10.4x ← 2: 10.5x ↗ 3: 10.7x ← 4: 10.7x ↘ 5: 10.9x ← 6: 10.8x ↗ 7: 10.9x ↗ 8: 10.7x ↘ 9: 10.4x ↗ 10: 10.4x ↗</p> <p>Serie 106.4 Total 106.4</p>	<p>60 Skott</p> 	<p>11: 10.7x ← 12: 10.4x ← 13: 10.2x ↗ 14: 10.2x ↗ 15: 10.6x ← 16: 10.5x ↗ 17: 10.8x ↗ 18: 10.5x ↘ 19: 10.2x ↗ 20: 10.4x ←</p> <p>Serie 104.5 Total 210.9</p>
<p>60 Skott</p> 	<p>21: 10.8x ↗ 22: 10.9x ← 23: 10.7x ← 24: 10.5x ↘ 25: 10.8x ↗ 26: 10.8x ↗ 27: 10.2x ↗ 28: 10.6x ← 29: 10.7x ↘ 30: 10.9x ↗</p> <p>Serie 106.9 Total 317.8</p>	<p>60 Skott</p> 	<p>31: 10.6x ↗ 32: 10.4x ← 33: 10.3x ↗ 34: 10.6x ← 35: 10.3x ↘ 36: 10.3x ↘ 37: 10.6x ↘ 38: 10.5x ↗ 39: 10.5x ↗ 40: 10.6x ↗</p> <p>Serie 104.7 Total 422.5</p>

Skjutlag 1	Tavla 25	Joel Bergqvist	
S		Umeå	
25.02.2017		Vännästräffen 2017	Umeå skytteallians
Pröv 	1: 7.5 ↙ 2: 8.5 ↙ 3: 8.4 ↙ 4: 9.2 ↙ 5: 9.6 ↙ 6: 10.0 ↙ 7: 9.5 ↙ 8: 10.2x ↘ 9: 10.4x ← 10: 10.4x ↘ Serie 93.7 Total 0.0	Pröv 	11: 10.7x ↘ 12: 10.5x ↘ 13: 10.8x ↑ 14: 10.3x ↗ 15: 10.8x ↑ 16: 10.5x ↘ 17: 10.0 → 18: 10.8x ↗ 19: 10.7x ↘ 20: 10.2x → Serie 105.3 Total 0.0
Pröv 	21: 10.6x ↘ 22: 10.5x ↘ 23: 10.8x ↑ 25: 10.7x ↗ Serie 42.6 Total 0.0	60 Skott 	1: 10.3x ↑ 2: 10.8x ↘ 3: 10.8x ↗ 4: 10.3x → 5: 10.6x ↘ 6: 10.9x ↘ 7: 10.7x ↘ 8: 10.8x ↗ 9: 10.8x ↘ 10: 10.8x ↘ Serie 106.8 Total 106.8
60 Skott 	11: 10.7x → 12: 10.5x ← 13: 10.8x ← 14: 10.2x ← 15: 10.4x ↗ 16: 10.6x ↘ 17: 10.9x ↗ 18: 10.8x ↘ 19: 10.3x ↘ 20: 10.6x ← Serie 105.8 Total 212.6	60 Skott 	21: 10.4x ↘ 22: 10.5x ↘ 23: 10.8x ↗ 24: 10.6x ← 25: 10.5x ← 26: 10.3x ← 27: 10.6x ↘ 28: 10.6x ↗ 29: 10.8x ↘ 30: 10.7x → Serie 105.8 Total 318.4
60 Skott 	31: 10.4x ↙ 32: 10.7x ← 33: 10.7x ↘ 34: 10.4x → 35: 10.9x ↘ 36: 10.8x ↗ 37: 10.7x ↘ 38: 10.3x ↗ 39: 10.4x ↘ 40: 10.6x ↗ Serie 105.9 Total 424.3		

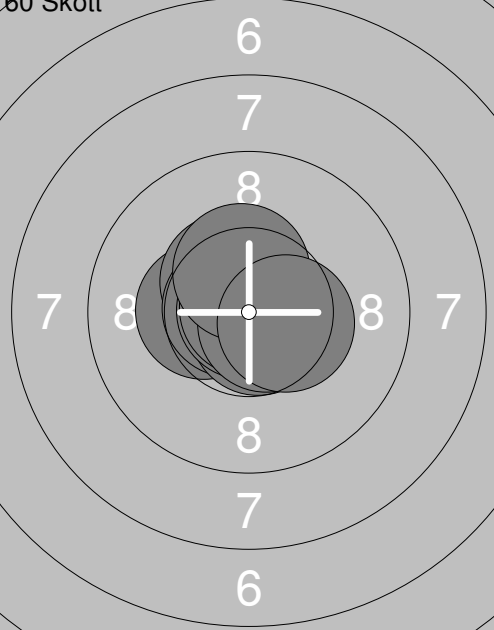
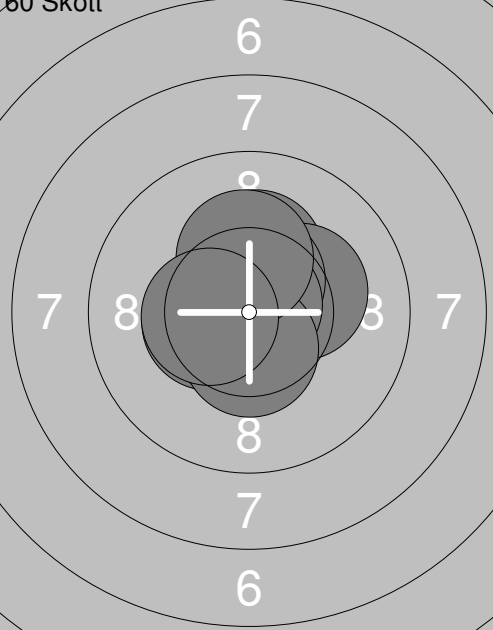
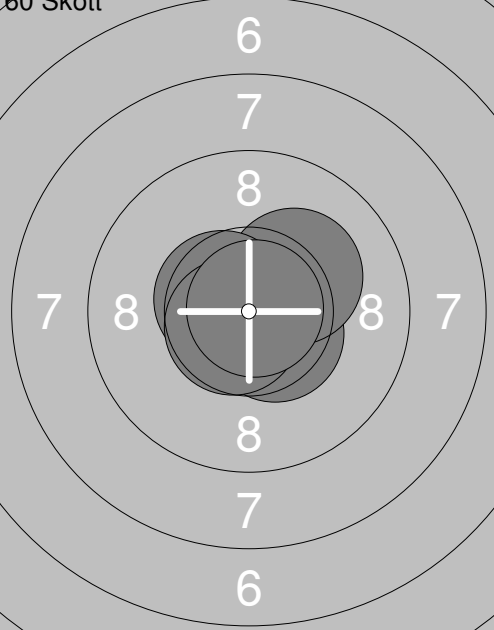
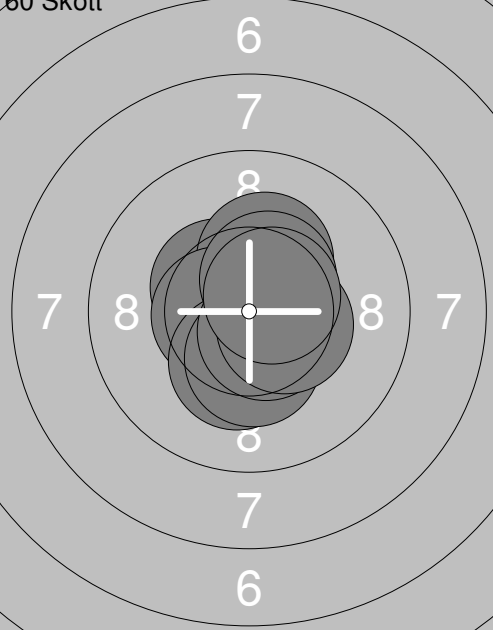
Prov 	1: 9.6 → 2: 9.7 ↑ 3: 10.1 ↓ 4: 10.0 ↓ 5: 10.8x ↑ 6: 10.7x ↓ 7: 10.5x ↘ 8: 10.5x ↓ 9: 10.3x ↑ 10: 9.6 ↑	Prov 	11: 10.7x ↗ 12: 10.6x ↓ 13: 10.0 ↓ 14: 10.9x ↗ 15: 10.6x ↓ 16: 10.2x ↙ 17: 10.5x ↓ 18: 10.4x ↓ 19: 10.4x → 20: 10.5x ↓
	Serie 101.8 Total 0.0		Serie 104.8 Total 0.0
	21: 9.4 → 22: 10.5x ↙ 23: 10.0 ↙ 24: 10.5x → 25: 10.0 ↑ 26: 9.5 ↗ 27: 10.5x ↓ 28: 10.1 ↗ 29: 9.2 ↑ 30: 9.9 ↗		31: 10.3x ↓ 32: 10.3x ↗ 33: 9.8 ← 34: 10.0 ↓ 35: 10.3x ↘
Serie 99.6 Total 0.0	Serie 50.7 Total 0.0		
60 Skott 	1: 10.6x ↓ 2: 10.2x ← 3: 10.5x → 4: 10.2x ↑ 5: 10.0 ↘ 6: 10.4x ↓ 7: 10.1 ↓ 8: 10.3x → 9: 9.9 ↓ 10: 10.1 →	60 Skott 	11: 10.6x ↓ 12: 9.9 → 13: 10.5x → 14: 9.9 ↓ 15: 10.1 ↓ 16: 9.8 → 17: 9.6 ↓ 18: 8.1 ↗ 19: 9.9 → 20: 10.7x ↗
	Serie 102.3 Total 102.3		Serie 99.1 Total 201.4
	21: 10.3x ↑ 22: 9.8 → 23: 10.2x ↑ 24: 10.3x ↓ 25: 10.6x → 26: 10.4x ↑ 27: 9.9 ← 28: 10.4x ↘ 29: 10.3x ← 30: 10.6x ↙		31: 10.3x ↓ 32: 10.4x ↙ 33: 9.4 ↓ 34: 10.0 → 35: 10.4x → 36: 10.6x ↓ 37: 10.5x ↓ 38: 10.8x ↓ 39: 10.6x ↓ 40: 9.2 ←
Serie 102.8 Total 304.2	Serie 102.2 Total 406.4		

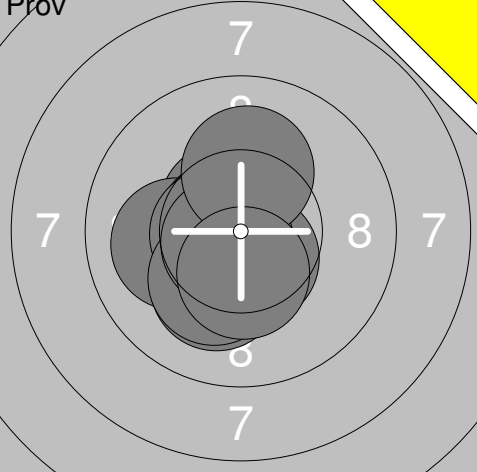
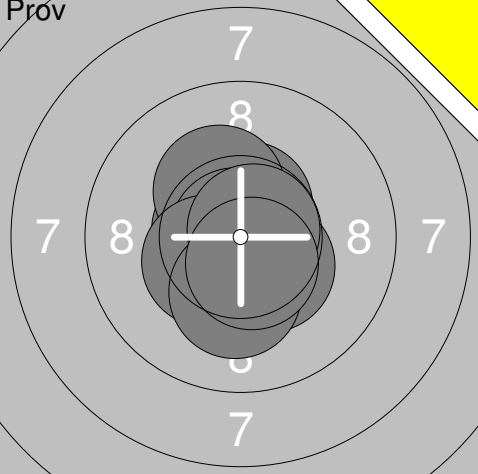
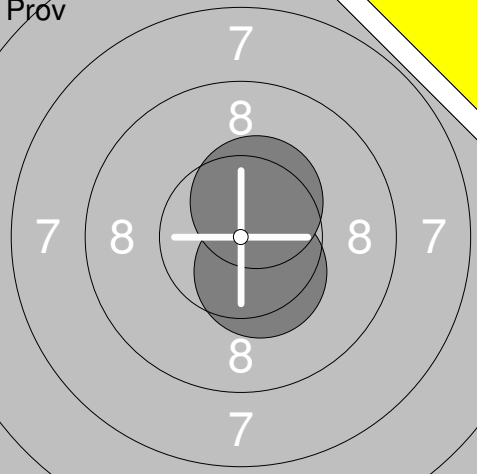
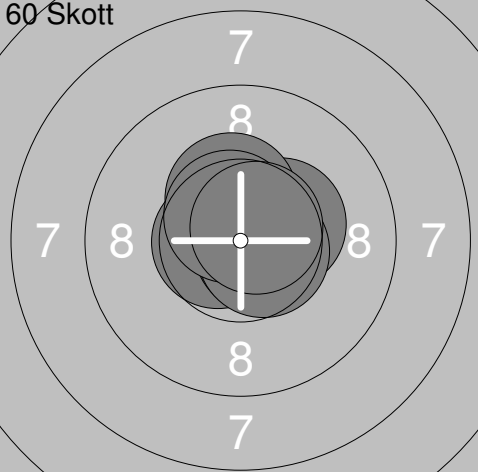
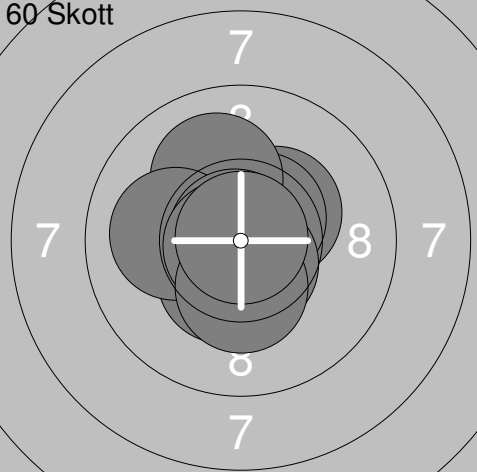
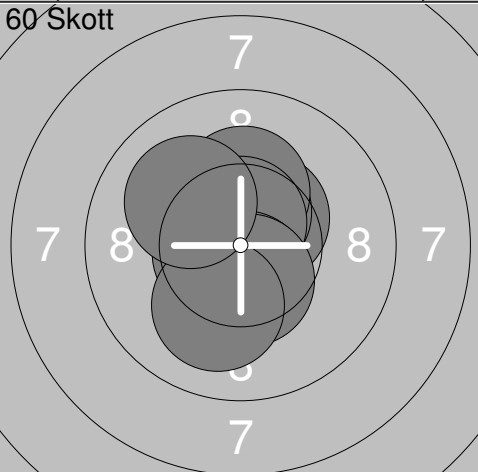
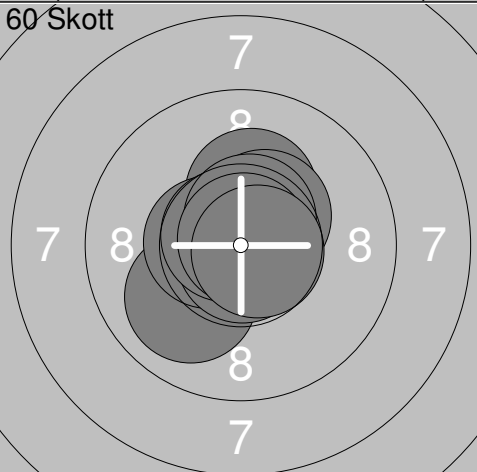
Pröv 	<table border="1" style="width:100%; border-collapse: collapse;"> <tr><td>1:</td><td>10.5x</td><td>↗</td></tr> <tr><td>2:</td><td>10.6x</td><td>↗</td></tr> <tr><td>3:</td><td>10.6x</td><td>→</td></tr> <tr><td>4:</td><td>10.6x</td><td>↗</td></tr> <tr><td>5:</td><td>10.7x</td><td>→</td></tr> <tr><td>6:</td><td>10.5x</td><td>↗</td></tr> <tr><td>7:</td><td>10.8x</td><td>→</td></tr> <tr><td>8:</td><td>10.6x</td><td>↘</td></tr> <tr><td>9:</td><td>10.1</td><td>↖</td></tr> <tr><td>10:</td><td>10.7x</td><td>↘</td></tr> <tr><td colspan="2">Serie</td><td>105.7</td></tr> <tr><td colspan="2">Total</td><td>0.0</td></tr> </table>	1:	10.5x	↗	2:	10.6x	↗	3:	10.6x	→	4:	10.6x	↗	5:	10.7x	→	6:	10.5x	↗	7:	10.8x	→	8:	10.6x	↘	9:	10.1	↖	10:	10.7x	↘	Serie		105.7	Total		0.0	Pröv 	<table border="1" style="width:100%; border-collapse: collapse;"> <tr><td>11:</td><td>10.6x</td><td>↗</td></tr> <tr><td>12:</td><td>10.6x</td><td>↘</td></tr> <tr><td>13:</td><td>10.1</td><td>↖</td></tr> <tr><td>14:</td><td>10.7x</td><td>↖</td></tr> <tr><td>15:</td><td>10.6x</td><td>↖</td></tr> <tr><td>16:</td><td>10.2x</td><td>↘</td></tr> <tr><td>17:</td><td>10.2x</td><td>↘</td></tr> <tr><td>18:</td><td>10.7x</td><td>↖</td></tr> <tr><td>19:</td><td>10.2x</td><td>↗</td></tr> <tr><td>20:</td><td>10.4x</td><td>↘</td></tr> <tr><td colspan="2">Serie</td><td>104.3</td></tr> <tr><td colspan="2">Total</td><td>0.0</td></tr> </table>	11:	10.6x	↗	12:	10.6x	↘	13:	10.1	↖	14:	10.7x	↖	15:	10.6x	↖	16:	10.2x	↘	17:	10.2x	↘	18:	10.7x	↖	19:	10.2x	↗	20:	10.4x	↘	Serie		104.3	Total		0.0
1:	10.5x	↗																																																																									
2:	10.6x	↗																																																																									
3:	10.6x	→																																																																									
4:	10.6x	↗																																																																									
5:	10.7x	→																																																																									
6:	10.5x	↗																																																																									
7:	10.8x	→																																																																									
8:	10.6x	↘																																																																									
9:	10.1	↖																																																																									
10:	10.7x	↘																																																																									
Serie		105.7																																																																									
Total		0.0																																																																									
11:	10.6x	↗																																																																									
12:	10.6x	↘																																																																									
13:	10.1	↖																																																																									
14:	10.7x	↖																																																																									
15:	10.6x	↖																																																																									
16:	10.2x	↘																																																																									
17:	10.2x	↘																																																																									
18:	10.7x	↖																																																																									
19:	10.2x	↗																																																																									
20:	10.4x	↘																																																																									
Serie		104.3																																																																									
Total		0.0																																																																									
Pröv 	<table border="1" style="width:100%; border-collapse: collapse;"> <tr><td>21:</td><td>10.5x</td><td>↗</td></tr> <tr><td>22:</td><td>10.6x</td><td>↖</td></tr> <tr><td>23:</td><td>10.3x</td><td>↗</td></tr> <tr><td>24:</td><td>10.9x</td><td>↗</td></tr> <tr><td>25:</td><td>10.7x</td><td>↘</td></tr> <tr><td>26:</td><td>10.4x</td><td>↖</td></tr> <tr><td>27:</td><td>10.4x</td><td>↘</td></tr> <tr><td>28:</td><td>10.8x</td><td>→</td></tr> <tr><td>29:</td><td>10.2x</td><td>↘</td></tr> <tr><td>30:</td><td>10.6x</td><td>↘</td></tr> <tr><td colspan="2">Serie</td><td>105.4</td></tr> <tr><td colspan="2">Total</td><td>0.0</td></tr> </table>	21:	10.5x	↗	22:	10.6x	↖	23:	10.3x	↗	24:	10.9x	↗	25:	10.7x	↘	26:	10.4x	↖	27:	10.4x	↘	28:	10.8x	→	29:	10.2x	↘	30:	10.6x	↘	Serie		105.4	Total		0.0	Pröv 	<table border="1" style="width:100%; border-collapse: collapse;"> <tr><td>31:</td><td>10.4x</td><td>↘</td></tr> <tr><td>32:</td><td>10.4x</td><td>↗</td></tr> <tr><td colspan="2">Serie</td><td>20.8</td></tr> <tr><td colspan="2">Total</td><td>0.0</td></tr> </table>	31:	10.4x	↘	32:	10.4x	↗	Serie		20.8	Total		0.0																								
21:	10.5x	↗																																																																									
22:	10.6x	↖																																																																									
23:	10.3x	↗																																																																									
24:	10.9x	↗																																																																									
25:	10.7x	↘																																																																									
26:	10.4x	↖																																																																									
27:	10.4x	↘																																																																									
28:	10.8x	→																																																																									
29:	10.2x	↘																																																																									
30:	10.6x	↘																																																																									
Serie		105.4																																																																									
Total		0.0																																																																									
31:	10.4x	↘																																																																									
32:	10.4x	↗																																																																									
Serie		20.8																																																																									
Total		0.0																																																																									
60 Skott 	<table border="1" style="width:100%; border-collapse: collapse;"> <tr><td>1:</td><td>10.8x</td><td>→</td></tr> <tr><td>2:</td><td>10.6x</td><td>→</td></tr> <tr><td>3:</td><td>10.5x</td><td>↗</td></tr> <tr><td>4:</td><td>10.4x</td><td>→</td></tr> <tr><td>5:</td><td>10.4x</td><td>↗</td></tr> <tr><td>6:</td><td>10.6x</td><td>↖</td></tr> <tr><td>7:</td><td>10.7x</td><td>↘</td></tr> <tr><td>8:</td><td>10.6x</td><td>↘</td></tr> <tr><td>9:</td><td>10.6x</td><td>↗</td></tr> <tr><td>10:</td><td>10.7x</td><td>↗</td></tr> <tr><td colspan="2">Serie</td><td>105.9</td></tr> <tr><td colspan="2">Total</td><td>105.9</td></tr> </table>	1:	10.8x	→	2:	10.6x	→	3:	10.5x	↗	4:	10.4x	→	5:	10.4x	↗	6:	10.6x	↖	7:	10.7x	↘	8:	10.6x	↘	9:	10.6x	↗	10:	10.7x	↗	Serie		105.9	Total		105.9	60 Skott 	<table border="1" style="width:100%; border-collapse: collapse;"> <tr><td>11:</td><td>10.4x</td><td>↗</td></tr> <tr><td>12:</td><td>10.6x</td><td>↗</td></tr> <tr><td>13:</td><td>10.6x</td><td>↘</td></tr> <tr><td>14:</td><td>10.4x</td><td>↘</td></tr> <tr><td>15:</td><td>10.1</td><td>↗</td></tr> <tr><td>16:</td><td>10.1</td><td>↖</td></tr> <tr><td>17:</td><td>10.8x</td><td>↗</td></tr> <tr><td>18:</td><td>10.8x</td><td>↖</td></tr> <tr><td>19:</td><td>10.3x</td><td>↘</td></tr> <tr><td>20:</td><td>10.9x</td><td>↗</td></tr> <tr><td colspan="2">Serie</td><td>105.0</td></tr> <tr><td colspan="2">Total</td><td>210.9</td></tr> </table>	11:	10.4x	↗	12:	10.6x	↗	13:	10.6x	↘	14:	10.4x	↘	15:	10.1	↗	16:	10.1	↖	17:	10.8x	↗	18:	10.8x	↖	19:	10.3x	↘	20:	10.9x	↗	Serie		105.0	Total		210.9
1:	10.8x	→																																																																									
2:	10.6x	→																																																																									
3:	10.5x	↗																																																																									
4:	10.4x	→																																																																									
5:	10.4x	↗																																																																									
6:	10.6x	↖																																																																									
7:	10.7x	↘																																																																									
8:	10.6x	↘																																																																									
9:	10.6x	↗																																																																									
10:	10.7x	↗																																																																									
Serie		105.9																																																																									
Total		105.9																																																																									
11:	10.4x	↗																																																																									
12:	10.6x	↗																																																																									
13:	10.6x	↘																																																																									
14:	10.4x	↘																																																																									
15:	10.1	↗																																																																									
16:	10.1	↖																																																																									
17:	10.8x	↗																																																																									
18:	10.8x	↖																																																																									
19:	10.3x	↘																																																																									
20:	10.9x	↗																																																																									
Serie		105.0																																																																									
Total		210.9																																																																									
60 Skott 	<table border="1" style="width:100%; border-collapse: collapse;"> <tr><td>21:</td><td>10.5x</td><td>↗</td></tr> <tr><td>22:</td><td>10.8x</td><td>↗</td></tr> <tr><td>23:</td><td>10.6x</td><td>↖</td></tr> <tr><td>24:</td><td>10.5x</td><td>↗</td></tr> <tr><td>25:</td><td>10.2x</td><td>↗</td></tr> <tr><td>26:</td><td>10.6x</td><td>↗</td></tr> <tr><td>27:</td><td>10.5x</td><td>↘</td></tr> <tr><td>28:</td><td>10.5x</td><td>↘</td></tr> <tr><td>29:</td><td>10.1</td><td>↘</td></tr> <tr><td>30:</td><td>10.1</td><td>↗</td></tr> <tr><td colspan="2">Serie</td><td>104.4</td></tr> <tr><td colspan="2">Total</td><td>315.3</td></tr> </table>	21:	10.5x	↗	22:	10.8x	↗	23:	10.6x	↖	24:	10.5x	↗	25:	10.2x	↗	26:	10.6x	↗	27:	10.5x	↘	28:	10.5x	↘	29:	10.1	↘	30:	10.1	↗	Serie		104.4	Total		315.3	60 Skott 	<table border="1" style="width:100%; border-collapse: collapse;"> <tr><td>31:</td><td>10.5x</td><td>↖</td></tr> <tr><td>32:</td><td>10.0</td><td>↖</td></tr> <tr><td>33:</td><td>10.3x</td><td>↗</td></tr> <tr><td>34:</td><td>10.5x</td><td>↖</td></tr> <tr><td>35:</td><td>10.8x</td><td>↘</td></tr> <tr><td>36:</td><td>10.4x</td><td>↗</td></tr> <tr><td>37:</td><td>10.7x</td><td>↖</td></tr> <tr><td>38:</td><td>10.6x</td><td>↗</td></tr> <tr><td>39:</td><td>10.9x</td><td>↗</td></tr> <tr><td>40:</td><td>10.7x</td><td>→</td></tr> <tr><td colspan="2">Serie</td><td>105.4</td></tr> <tr><td colspan="2">Total</td><td>420.7</td></tr> </table>	31:	10.5x	↖	32:	10.0	↖	33:	10.3x	↗	34:	10.5x	↖	35:	10.8x	↘	36:	10.4x	↗	37:	10.7x	↖	38:	10.6x	↗	39:	10.9x	↗	40:	10.7x	→	Serie		105.4	Total		420.7
21:	10.5x	↗																																																																									
22:	10.8x	↗																																																																									
23:	10.6x	↖																																																																									
24:	10.5x	↗																																																																									
25:	10.2x	↗																																																																									
26:	10.6x	↗																																																																									
27:	10.5x	↘																																																																									
28:	10.5x	↘																																																																									
29:	10.1	↘																																																																									
30:	10.1	↗																																																																									
Serie		104.4																																																																									
Total		315.3																																																																									
31:	10.5x	↖																																																																									
32:	10.0	↖																																																																									
33:	10.3x	↗																																																																									
34:	10.5x	↖																																																																									
35:	10.8x	↘																																																																									
36:	10.4x	↗																																																																									
37:	10.7x	↖																																																																									
38:	10.6x	↗																																																																									
39:	10.9x	↗																																																																									
40:	10.7x	→																																																																									
Serie		105.4																																																																									
Total		420.7																																																																									

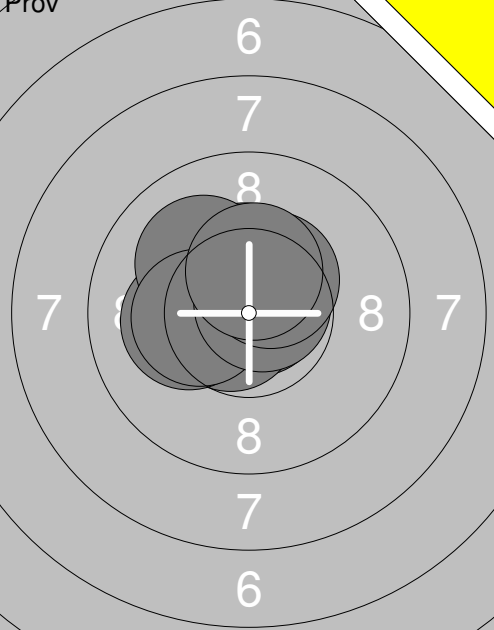
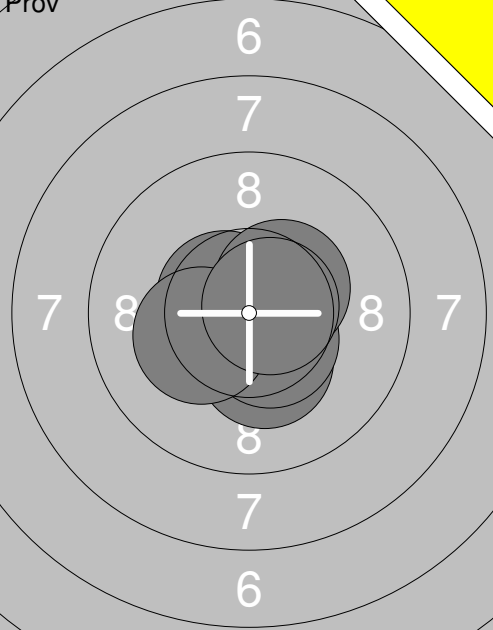
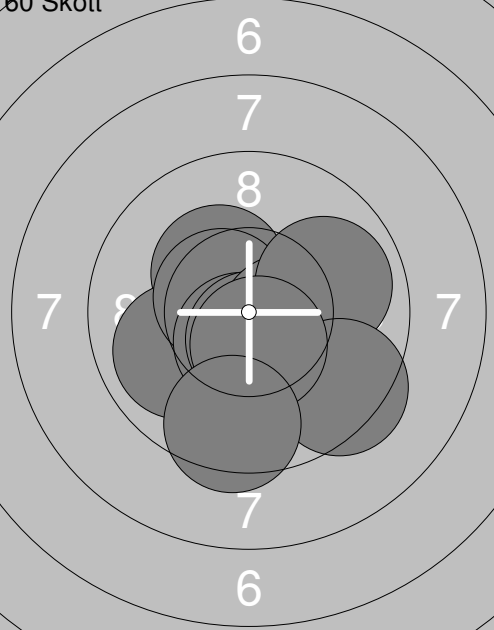
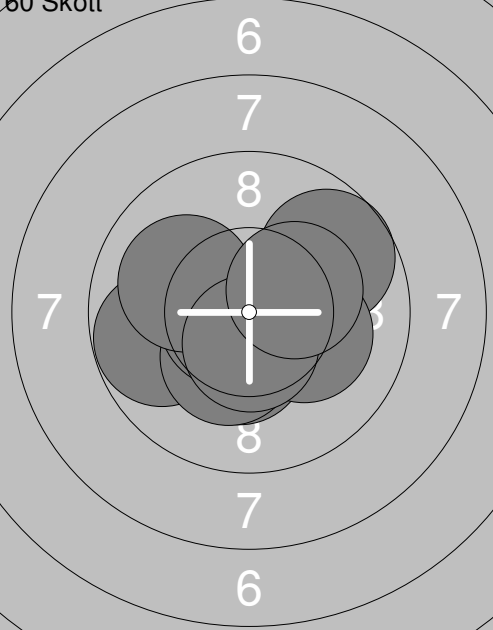
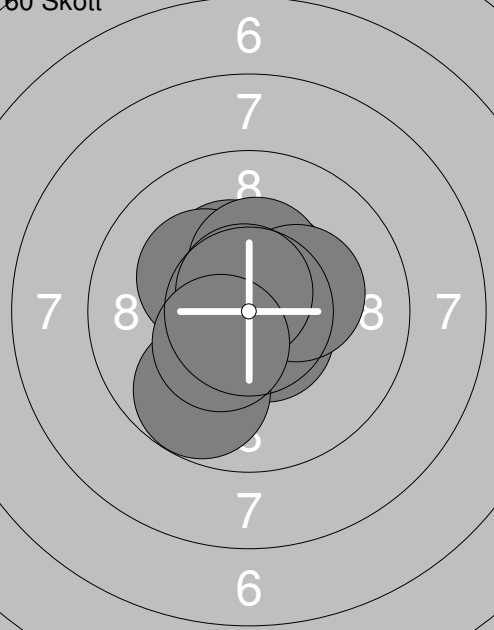
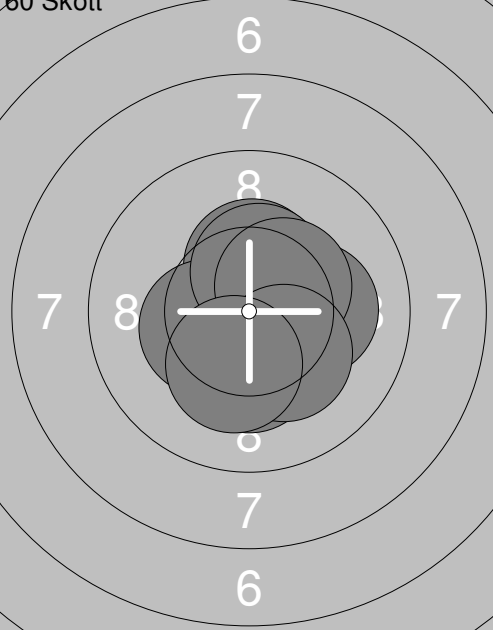
<p>Prov</p>  <p style="text-align: center;">6 7 8 7 8 7 6</p>	<p>1: 10.8x ↗ 2: 10.4x ↗ 3: 10.7x ↘ 4: 10.2x ↘ 5: 10.1 ↖ 6: 10.3x ↘ 7: 10.7x ↗ 8: 10.4x ↗ 9: 10.4x ↗</p> <p>Serie 94.0 Total 0.0</p>	<p>Prov</p>  <p style="text-align: center;">6 7 8 7 8 7 6</p> <p>11: 10.6x ↘ 12: 10.3x ↘ 13: 10.5x ↘ 14: 10.3x ↘ 16: 10.4x ↗ 17: 10.7x ↗</p> <p>Serie 62.8 Total 0.0</p>
<p>60 Skott</p>  <p style="text-align: center;">6 7 8 7 8 7 6</p>	<p>1: 10.3x ↘ 2: 9.9 ↖ 3: 10.5x ↘ 4: 10.6x ↘ 5: 10.6x ↘ 6: 10.4x ➤ 7: 9.9 ➤ 8: 9.4 ↘ 9: 10.5x ↘ 10: 9.5 ↘</p> <p>Serie 101.6 Total 101.6</p>	<p>60 Skott</p>  <p style="text-align: center;">6 7 8 7 8 7 6</p> <p>11: 9.8 ↖ 12: 9.7 ↗ 13: 10.7x ➤ 14: 10.4x ↘ 15: 10.3x ↘ 16: 10.2x ➤ 17: 10.7x ↘ 18: 10.1 ↖ 19: 10.5x ↘ 20: 10.3x ➤</p> <p>Serie 102.7 Total 204.3</p>
<p>60 Skott</p>  <p style="text-align: center;">6 7 8 7 8 7 6</p>	<p>21: 10.7x ↘ 22: 10.4x ↗ 23: 10.3x ↗ 24: 10.2x ↘ 25: 10.3x ↗ 26: 10.6x ↘ 27: 9.8 ↘ 28: 10.3x ➤ 29: 10.7x ↗ 30: 10.4x ↘</p> <p>Serie 103.7 Total 308.0</p>	<p>60 Skott</p>  <p style="text-align: center;">6 7 8 7 8 7 6</p> <p>31: 10.8x ↘ 32: 10.2x ➤ 33: 10.4x ↗ 34: 10.7x ↘ 35: 10.4x ↘ 36: 10.4x ↗ 37: 10.3x ↘ 38: 10.4x ➤ 39: 10.2x ↘ 40: 10.2x ↘</p> <p>Serie 104.0 Total 412.0</p>

	1: 10.2x↗		11: 10.3x↗
	2: 10.2x↗		12: 10.6x➤
	3: 10.2x↘		13: 10.1↗
	4: 10.4x↗		14: 10.2x➤
	5: 10.1➔		15: 10.5x↘
	6: 10.3x➤		
	7: 9.6↓		
	8: 10.4x↗		
	9: 9.9↓		
	10: 10.4x➤		
	Serie 101.7		Serie 51.7
	Total 0.0		Total 0.0

	1: 10.5x↘		11: 9.9➔
	2: 10.1↗		12: 10.4x➤
	3: 10.5x➤		13: 10.3x↗
	4: 10.0➔		14: 10.6x↗
	5: 9.6➤		15: 10.3x➤
	6: 10.2x➤		16: 9.9↗
	7: 10.6x➤		17: 10.1➔
	8: 10.4x↘		18: 10.6x↗
	9: 10.0➔		19: 10.3x↖
	10: 10.4x↘		20: 10.0↖
	Serie 102.3		Serie 102.4
	Total 102.3		Total 204.7

	21: 10.7x↘		31: 10.7x↘
	22: 10.6x↗		32: 10.3x↗
	23: 10.6x➤		33: 10.0↙
	24: 10.4x↖		34: 9.9↖
	25: 10.3x↖		35: 10.3x↘
	26: 10.1➔		36: 9.7↗
	27: 10.3x↗		37: 10.0↗
	28: 10.8x↘		38: 10.6x➤
	29: 10.1↗		39: 10.3x↖
	30: 10.6x↖		40: 10.4x➤
	Serie 104.5		Serie 102.2
	Total 309.2		Total 411.4

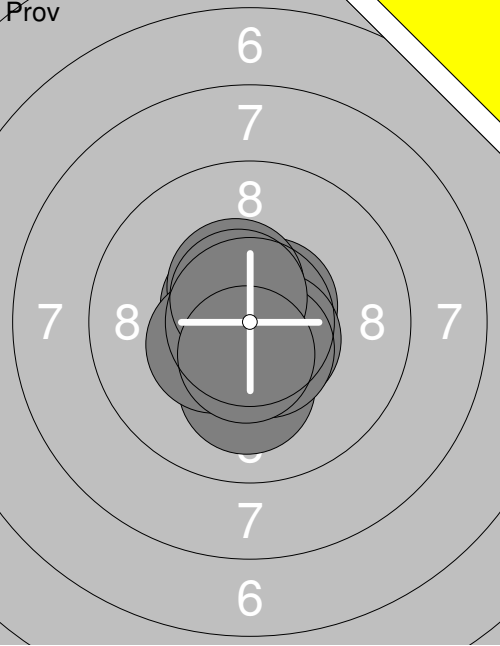
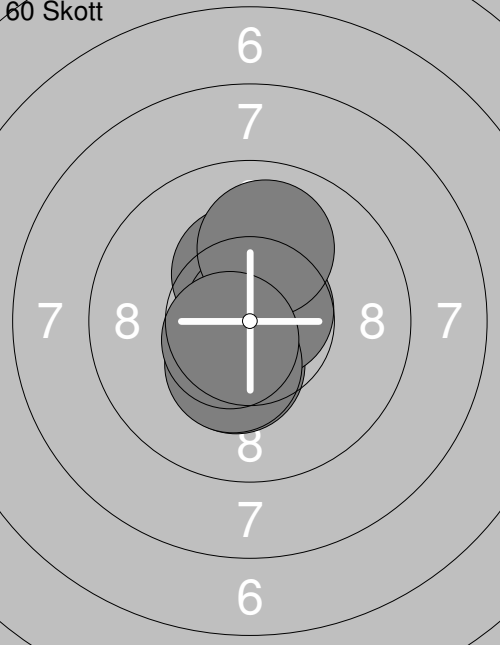
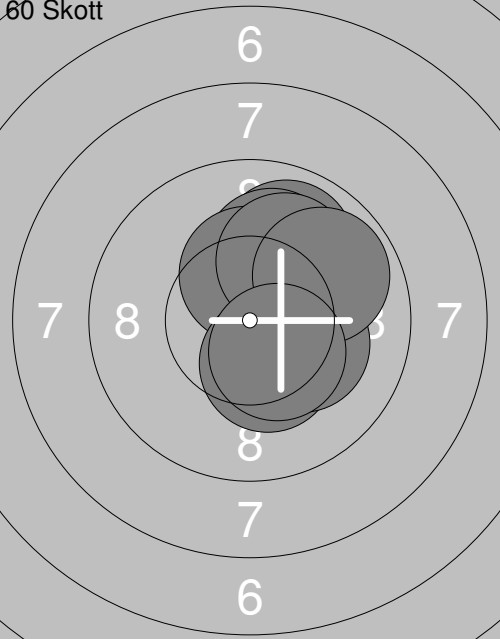
Skjutlag	Tavla	Irma Karlsson	
S	Vännäs		
25.02.2017	Vännästräffen 2017	Umeå skytteallians	
Prov		1: 10.6x ↗ 2: 10.6x ↘ 3: 10.1 ↓ 4: 10.5x ↘ 5: 10.6x ↗ 6: 10.5x ↗ 7: 10.6x ↘ 8: 10.4x ↘ 9: 10.6x ↗ 10: 10.5x ↘ Serie 105.0 Total 0.0	11: 10.0 ↑ 12: 10.8x ↘ Serie 20.8 Total 0.0
60 Skott		1: 10.4x ↗ 2: 10.4x ↘ 3: 10.8x ↗ 4: 10.8x ↗ 5: 10.3x ↗ 6: 10.9x ↗ 7: 10.7x ↗ 8: 10.0 ↑ 9: 10.3x ↘ 10: 10.6x ↘ Serie 105.2 Total 105.2	11: 10.5x ↘ 12: 10.5x ↘ 13: 10.7x ↗ 14: 9.8 ↓ 15: 10.8x ↗ 16: 10.6x ↘ 17: 10.3x ↘ 18: 10.3x ↘ 19: 9.5 ↗ 20: 10.6x ↗ Serie 103.6 Total 208.8
60 Skott		21: 9.9 ↗ 22: 10.1 ↗ 23: 10.4x ↗ 24: 10.4x ↘ 25: 10.3x ↘ 26: 10.3x ↗ 27: 10.2x ↗ 28: 10.1 ↗ 29: 9.9 ↗ 30: 10.4x ↘ Serie 102.0 Total 310.8	31: 10.6x ↗ 32: 10.6x ↗ 33: 10.6x ↗ 34: 10.5x ↘ 35: 10.6x ↘ 36: 10.7x ↗ 37: 10.5x ↗ 38: 10.0 → 39: 10.0 ↗ 40: 10.9x ↗ Serie 105.0 Total 415.8

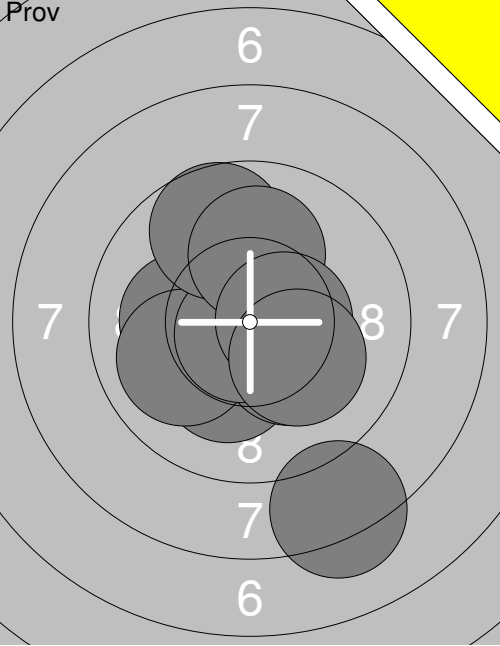
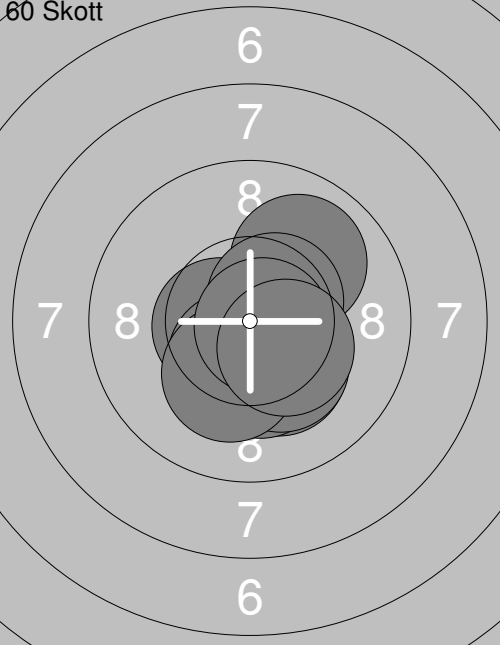
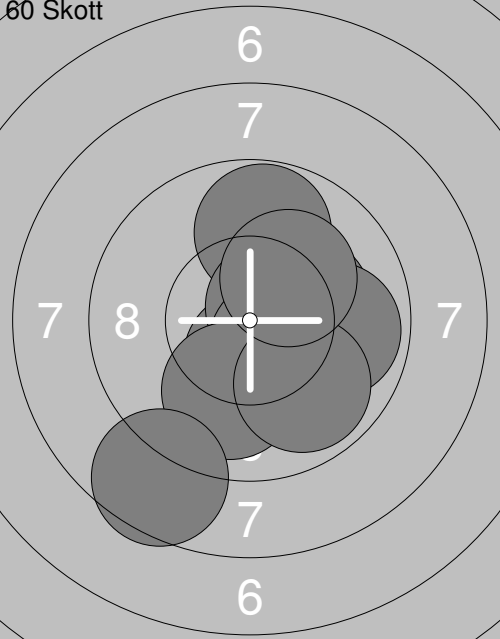
Skjuttlag	Tavla	Linnea Nilsson	
1	33		
S	Umeå		
25.02.2017	Vännästräffen 2017	Umeå skytteallians	
Prov		1: 10.2x↘ 2: 10.1← 3: 10.0↙ 4: 10.3x↘ 5: 8.2 ↓ 6: 10.8x↘ 7: 9.7 ↑ 8: 10.1 ↑ 9: 10.5x→ 10: 10.2x↘ Serie 100.1 Total 0.0	11: 9.7 ↘ 12: 10.3x↗ Serie 20.0 Total 0.0
60 Skott		1: 10.6x↙ 2: 10.0 ↗ 3: 10.2x↘ 4: 10.3x↘ 5: 10.5x↗ 6: 10.4x↘ 7: 10.3x↘ 8: 10.2x↘ 9: 10.8x↘ 10: 10.4x↘ Serie 103.7 Total 103.7	11: 10.7x↘ 12: 9.8 ↑ 13: 10.2x↘ 14: 9.1 ↖ 15: 10.4x→ 16: 10.1 ↖ 17: 10.4x↘ 18: 9.7 ↘ 19: 9.7 ↑ 20: 10.4x↙ Serie 100.5 Total 204.2
60 Skott		21: 10.2x→ 22: 9.8 ↑ 23: 10.5x↘ 24: 10.6x↗ 25: 10.5x↘ 26: 10.0 ↓ 27: 9.9 → 28: 8.6 ↓ 29: 9.9 ↘ 30: 10.2x↗ Serie 100.2 Total 304.4	31: 10.5x→ 32: 10.1→ 33: 10.5x↙ 34: 10.6x→ 35: 9.7 ↓ 36: 9.7 ↘ 37: 10.2x→ 38: 8.9 ↗ 39: 10.3x→ 40: 9.9 ↓ Serie 100.4 Total 404.8

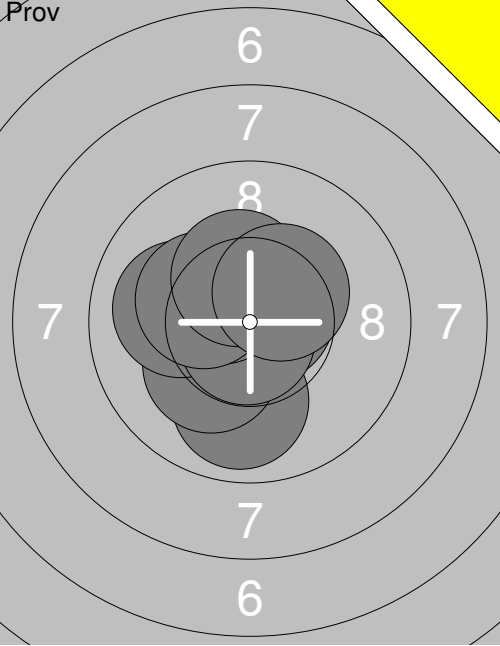
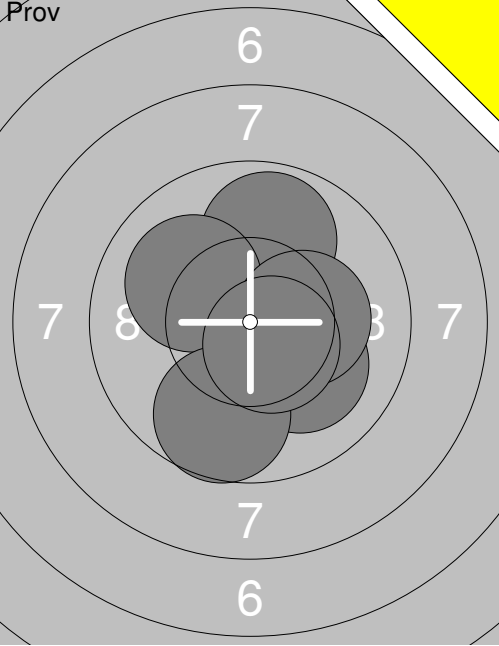
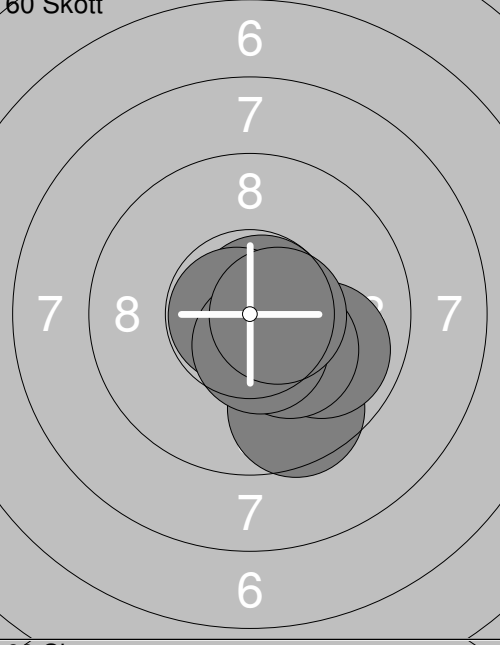
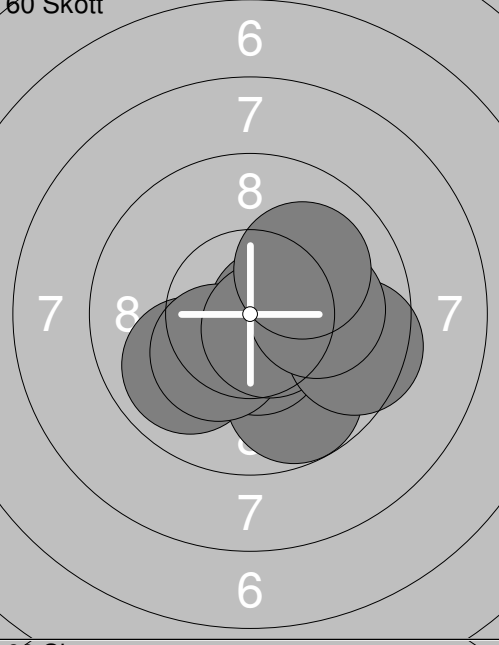
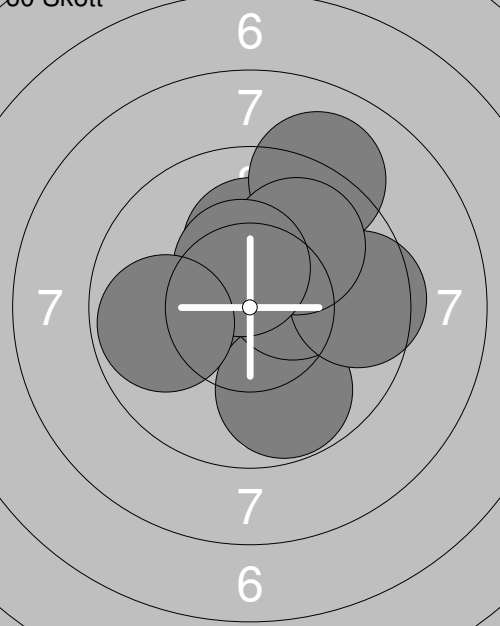
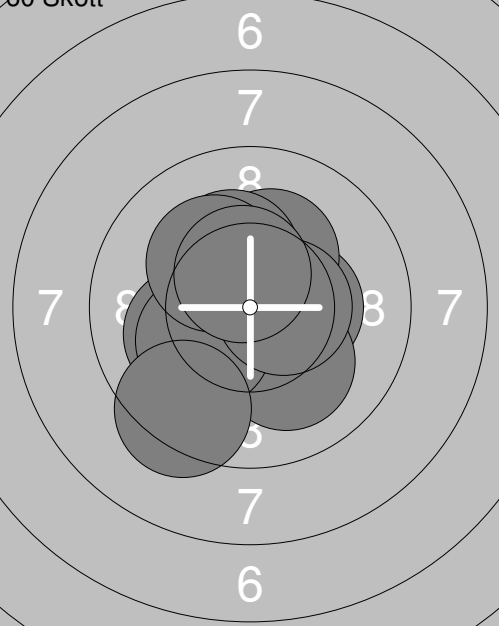
Skjuttlag	Tavla	Ari Perkiömäki	
1	34		
S	Umeå		
25.02.2017	Vännästräffen 2017	Umeå skytteallians	
Prov		Prov	
	1: 9.9 ↓ 2: 10.7x↗ 3: 10.2x↘ 5: 10.0← 6: 10.8x↓ 7: 10.4x↘ 8: 10.3x↘ 9: 10.4x↗ 10: 10.4x↗		11: 9.9 ↑ 12: 10.1↖ 13: 10.1↘ 14: 9.7 ↓ 15: 10.3x→ 16: 10.5x↘
	Serie 93.1		Serie 60.6
	Total 0.0		Total 0.0
60 Skott		60 Skott	
	1: 10.9x↓ 2: 10.7x↗ 3: 9.6 ↓ 4: 10.1 ↘ 5: 10.6x→ 6: 9.9 ↘ 7: 10.8x← 8: 10.3x↘ 9: 10.5x↓ 10: 10.6x→		11: 9.9 ↖ 12: 10.6x→ 13: 10.5x↓ 14: 9.7 ↓ 15: 10.5x↓ 16: 10.3x↘ 17: 10.6x↘ 18: 9.5 → 19: 10.1→ 20: 10.1 ↗
	Serie 104.0		Serie 101.8
	Total 104.0		Total 205.8
60 Skott		60 Skott	
	21: 10.1 ↑ 22: 9.1 ↑ 23: 10.7x→ 24: 10.1 ↗ 25: 9.8 ↓ 26: 10.4x→ 27: 9.5 → 28: 9.9 ↗ 29: 10.4x↗ 30: 9.8 ←		31: 10.4x→ 32: 10.1 ↘ 33: 10.2x↗ 34: 10.1↖ 35: 10.3x↗ 36: 10.2x↘ 37: 10.5x→ 38: 10.2x↘ 39: 9.4 ↓ 40: 10.5x↗
	Serie 99.8		Serie 101.9
	Total 305.6		Total 407.5

<p>Prov</p>	<p>1: 10.2x↘ 2: 9.9 ↓ 3: 9.5 ↘ 4: 10.2x↘ 5: 10.7x↘ 6: 10.4x↘ 7: 10.3x↘ 8: 10.9x↘ 9: 10.3x↘ 10: 10.2x↘</p> <p>Serie 102.6 Total 0.0</p>	<p>Prov</p>	<p>11: 10.4x↘ 12: 10.6x↗ 13: 9.8 ↓ 14: 10.2x↘ 15: 9.5 ← 16: 10.1 ↓ 17: 9.6 ➤ 18: 10.1 ↓ 19: 10.3x↘</p> <p>Serie 90.6 Total 0.0</p>
<p>60 Skott</p>	<p>1: 10.1 ➤ 2: 10.2x➤ 3: 10.5x↗ 4: 10.7x↗ 5: 10.5x➤ 6: 10.1 ➤ 7: 10.0 ↖ 8: 10.1 ↗ 9: 10.5x↖ 10: 10.0 ←</p> <p>Serie 102.7 Total 102.7</p>	<p>60 Skott</p>	<p>11: 10.7x➤ 12: 10.2x↘ 13: 10.5x➤ 14: 10.3x➤ 15: 9.8 ↙ 16: 9.1 ↓ 17: 10.1 ↓ 18: 9.8 ➤ 19: 10.5x↘ 20: 9.6 ↓</p> <p>Serie 100.6 Total 203.3</p>
<p>60 Skott</p>	<p>21: 9.6 ↓ 22: 10.7x↗ 23: 10.5x↗ 24: 10.3x↖ 25: 10.0 ↓ 26: 10.3x↖ 27: 10.2x↖ 28: 10.7x↗ 29: 10.3x↗ 30: 9.9 ↗</p> <p>Serie 102.5 Total 305.8</p>	<p>60 Skott</p>	<p>31: 10.6x↖ 32: 10.1 ↗ 33: 10.2x↖ 34: 10.7x➤ 35: 9.8 ↖ 36: 9.8 ↓ 37: 10.1 ↙ 38: 9.9 ➤ 39: 10.4x↗ 40: 10.5x↘</p> <p>Serie 102.1 Total 407.9</p>

	1: 9.1 ↙		11: 10.5x↓
	2: 9.8 ↘		12: 9.4 ←
	3: 10.2x↓		13: 9.6 ↙
	4: 10.7x↗		14: 10.3x↓
	5: 9.7 ↓		15: 10.3x↘
	6: 10.4x↘		16: 9.7 ←
	7: 10.5x↘		17: 10.1 ↓
	8: 9.6 ↓		18: 10.5x↓
	9: 9.6 →		19: 10.3x↗
	10: 10.7x↘		
Serie 100.3		Serie 90.7	
Total 0.0		Total 0.0	

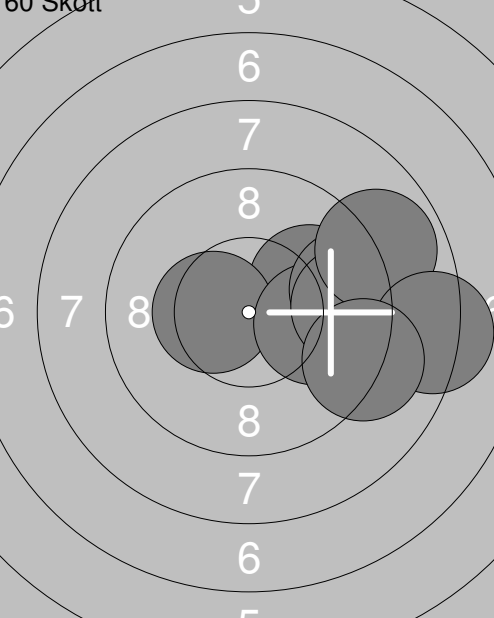
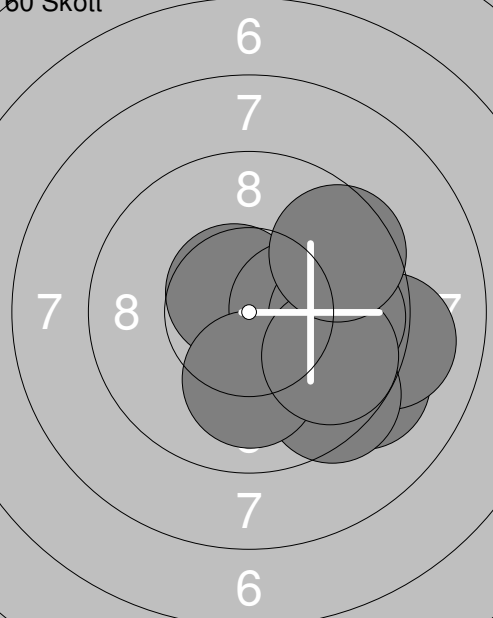
	1: 10.0 →		11: 10.4x↓
	2: 9.3 →		12: 10.6x↗
	3: 10.4x←		13: 10.3x→
	4: 10.0 →		14: 9.2 ↘
	5: 9.4 →		15: 9.1 →
	6: 9.1 →		16: 9.8 →
	7: 9.4 →		17: 9.4 ↓
	8: 8.9 ↗		18: 10.1 ↓
	9: 8.2 →		19: 9.7 ↘
	10: 9.1 →		20: 9.6 ↗
Serie 93.8		Serie 98.2	
Total 93.8		Total 192.0	

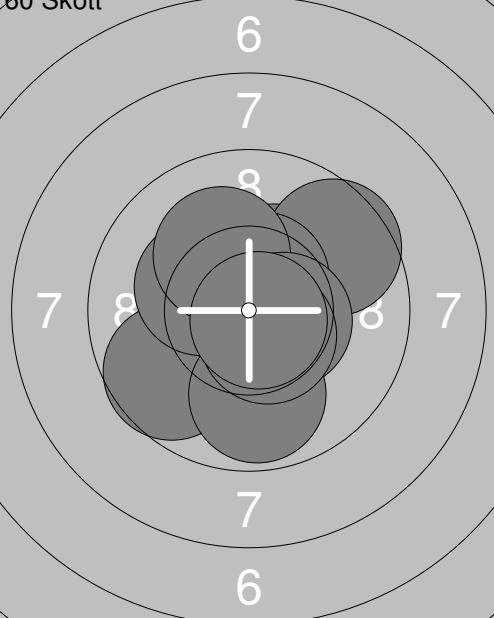
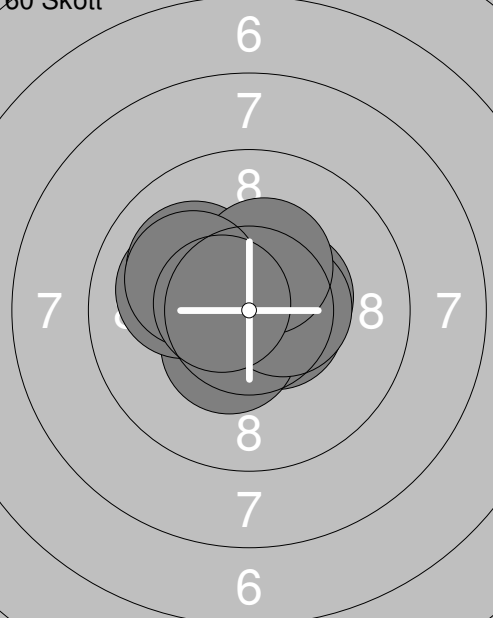
	21: 10.4x↗		31: 10.8x↗
	22: 9.6 ↗		32: 10.6x↘
	23: 10.5x↗		33: 10.4x↘
	24: 9.7 ↙		34: 10.1 ←
	25: 10.3x↘		35: 10.5x→
	26: 10.1 ↖		36: 10.1 ↖
	27: 10.5x→		37: 10.5x→
	28: 9.9 ↓		38: 10.3x↗
	29: 10.5x↓		39: 10.1 ↖
	30: 10.8x↓		40: 10.6x↘
Serie 102.3		Serie 104.0	
Total 294.3		Total 398.3	

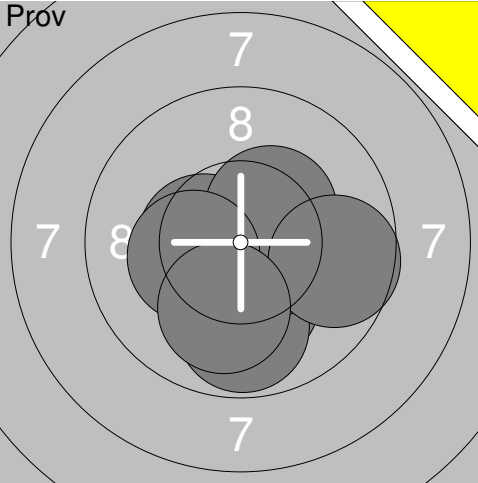
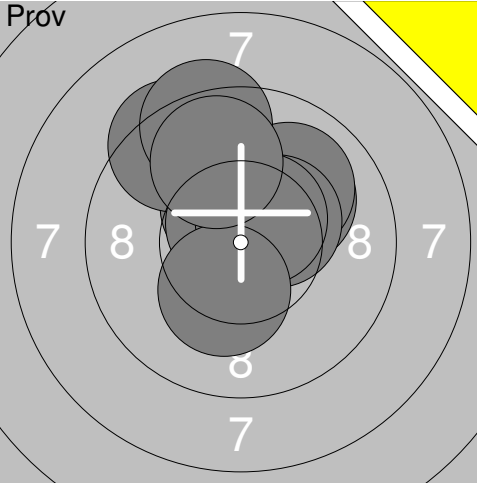
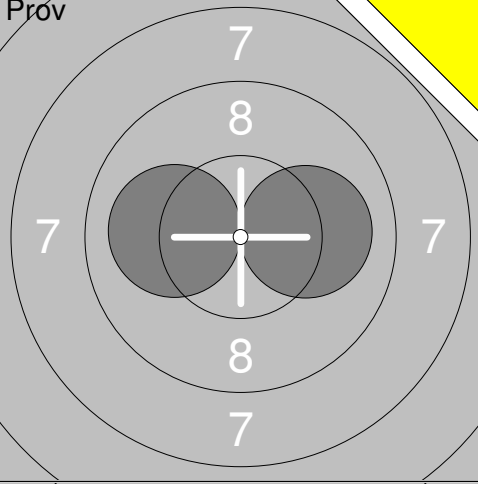
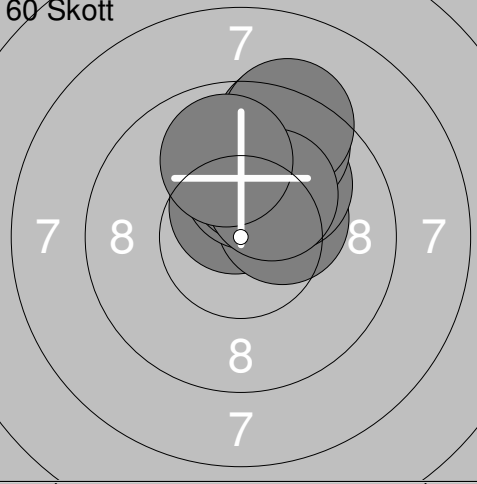
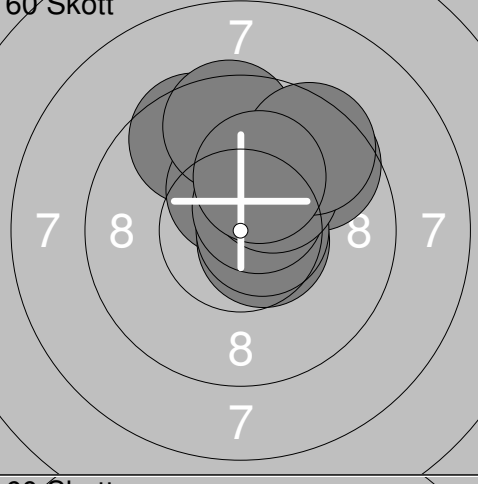
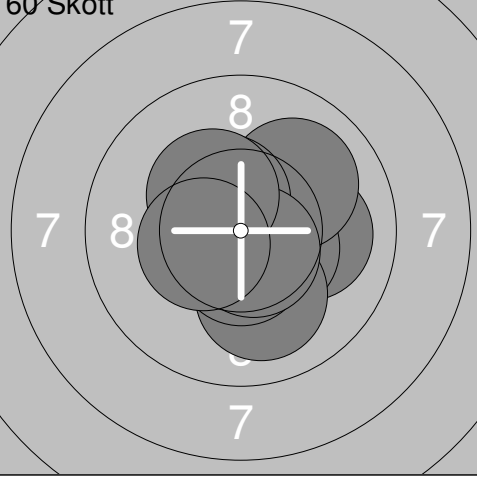
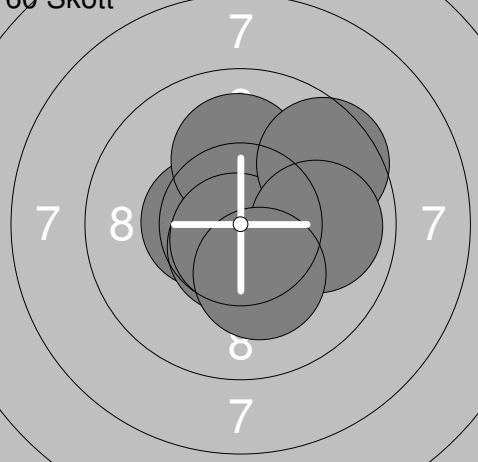
Skjutlag 1	Tavla 37	Vanja Hendriksson			
S		Vännäs			
25.02.2017		Vännästräffen 2017	Umeå skytteallians		
Prov		1: 10.3x → 2: 10.9x ↗ 3: 10.2x ↓ 4: 9.8 ↓ 5: 10.5x → 6: 10.5x ← 7: 10.4x ↗ 8: 10.3x ← 9: 9.7 → 10: 10.0 ↓ Serie 102.6 Total 0.0	Prov		11: 10.4x ↗ 12: 10.1 ↗ 13: 10.0 ↗ 14: 9.4 ↖ 15: 10.7x ↗ 16: 10.4x ↗ 17: 9.3 ↗ 18: 10.5x ↗ 19: 10.3x ↓ 20: 9.8 ↗ Serie 100.9 Total 0.0
Prov		21: 10.1 → 22: 10.1 ← Serie 20.2 Total 0.0	60 Skott		1: 10.5x ↗ 2: 10.3x → 3: 10.0 ↗ 4: 9.4 ↗ 5: 9.6 ↗ 6: 10.2x ↗ 7: 10.1 ↗ 8: 9.3 ↗ 9: 10.2x ↗ 10: 9.9 ↗ Serie 99.5 Total 99.5
60 Skott		11: 9.6 ↖ 12: 10.4x ↗ 13: 9.6 ↗ 14: 9.5 ↗ 15: 10.6x → 16: 10.7x → 17: 10.6x ↗ 18: 10.2x ↗ 19: 9.5 ↗ 20: 10.2x ↗ Serie 100.9 Total 200.4	60 Skott		21: 10.4x → 22: 10.1 → 23: 10.4x → 24: 10.0 ↗ 25: 10.0 ↓ 26: 10.6x ↓ 27: 10.5x ↗ 28: 10.6x ↓ 29: 10.3x ↗ 30: 10.4x ← Serie 103.3 Total 303.7
60 Skott		31: 10.5x ← 32: 10.1 → 33: 10.1 → 34: 10.6x ↓ 35: 10.8x ↗ 36: 10.1 ↗ 37: 10.7x ↓ 38: 9.6 ↗ 39: 9.9 → 40: 10.2x ↓ Serie 102.6 Total 406.3			

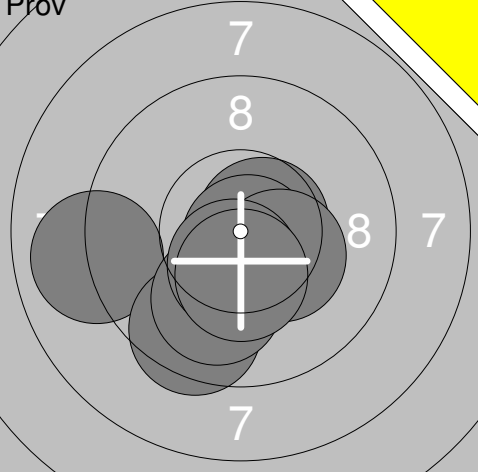
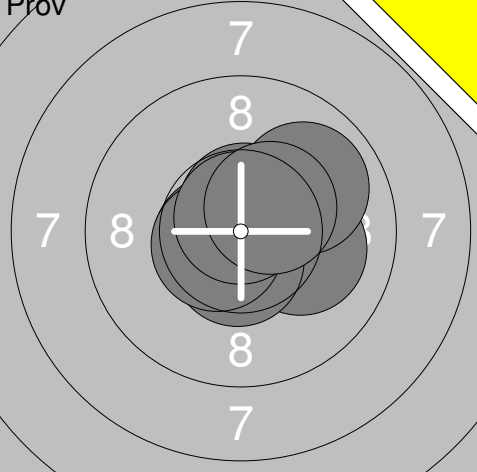
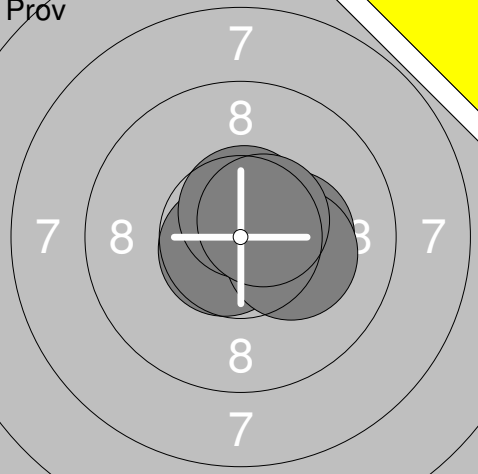
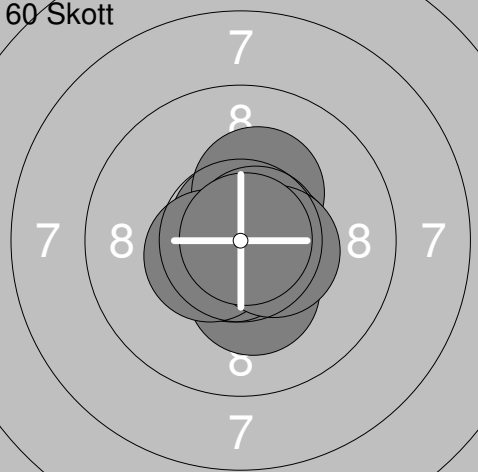
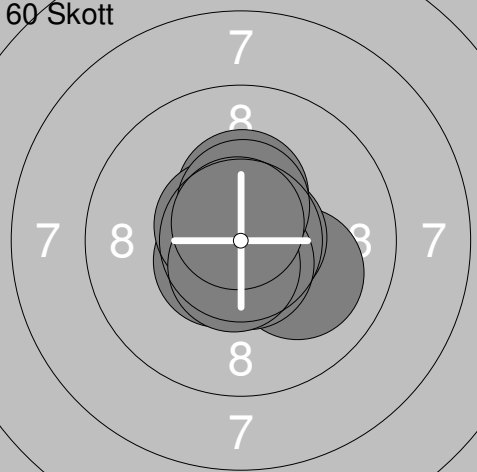
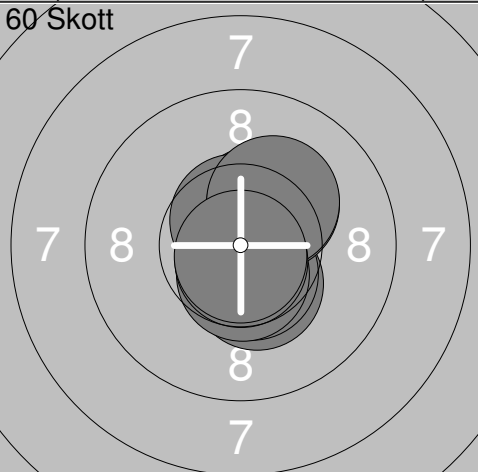
<p>Prov</p> 	<table border="1" style="width:100%; border-collapse: collapse;"> <tr><td>1:</td><td>9.0</td><td>←</td></tr> <tr><td>2:</td><td>9.5</td><td>↓</td></tr> <tr><td>3:</td><td>10.0</td><td>↓</td></tr> <tr><td>4:</td><td>10.6x</td><td>→</td></tr> <tr><td>5:</td><td>10.5x</td><td>↓</td></tr> <tr><td>6:</td><td>10.8x</td><td>↓</td></tr> <tr><td>7:</td><td>10.3x</td><td>→</td></tr> <tr><td>8:</td><td>10.5x</td><td>↓</td></tr> <tr><td>9:</td><td>10.4x</td><td>↓</td></tr> <tr><td colspan="2">Serie</td><td style="text-align: right;">91.6</td></tr> <tr><td colspan="2">Total</td><td style="text-align: right;">0.0</td></tr> </table>	1:	9.0	←	2:	9.5	↓	3:	10.0	↓	4:	10.6x	→	5:	10.5x	↓	6:	10.8x	↓	7:	10.3x	→	8:	10.5x	↓	9:	10.4x	↓	Serie		91.6	Total		0.0	<p>Prov</p> 	<table border="1" style="width:100%; border-collapse: collapse;"> <tr><td>11:</td><td>10.9x</td><td>↖</td></tr> <tr><td>12:</td><td>10.1</td><td>→</td></tr> <tr><td>13:</td><td>10.6x</td><td>←</td></tr> <tr><td>14:</td><td>10.7x</td><td>↑</td></tr> <tr><td>15:</td><td>9.9</td><td>↗</td></tr> <tr><td>16:</td><td>10.6x</td><td>↓</td></tr> <tr><td>17:</td><td>10.6x</td><td>←</td></tr> <tr><td>18:</td><td>10.8x</td><td>↑</td></tr> <tr><td>19:</td><td>10.4x</td><td>↗</td></tr> <tr><td colspan="2">Serie</td><td style="text-align: right;">94.6</td></tr> <tr><td colspan="2">Total</td><td style="text-align: right;">0.0</td></tr> </table>	11:	10.9x	↖	12:	10.1	→	13:	10.6x	←	14:	10.7x	↑	15:	9.9	↗	16:	10.6x	↓	17:	10.6x	←	18:	10.8x	↑	19:	10.4x	↗	Serie		94.6	Total		0.0						
1:	9.0	←																																																																									
2:	9.5	↓																																																																									
3:	10.0	↓																																																																									
4:	10.6x	→																																																																									
5:	10.5x	↓																																																																									
6:	10.8x	↓																																																																									
7:	10.3x	→																																																																									
8:	10.5x	↓																																																																									
9:	10.4x	↓																																																																									
Serie		91.6																																																																									
Total		0.0																																																																									
11:	10.9x	↖																																																																									
12:	10.1	→																																																																									
13:	10.6x	←																																																																									
14:	10.7x	↑																																																																									
15:	9.9	↗																																																																									
16:	10.6x	↓																																																																									
17:	10.6x	←																																																																									
18:	10.8x	↑																																																																									
19:	10.4x	↗																																																																									
Serie		94.6																																																																									
Total		0.0																																																																									
<p>Prov</p> 	<table border="1" style="width:100%; border-collapse: collapse;"> <tr><td>21:</td><td>10.7x</td><td>↖</td></tr> <tr><td>22:</td><td>10.3x</td><td>→</td></tr> <tr><td>23:</td><td>10.6x</td><td>↑</td></tr> <tr><td>25:</td><td>10.2x</td><td>→</td></tr> <tr><td>26:</td><td>10.6x</td><td>↗</td></tr> <tr><td colspan="2">Serie</td><td style="text-align: right;">52.4</td></tr> <tr><td colspan="2">Total</td><td style="text-align: right;">0.0</td></tr> </table>	21:	10.7x	↖	22:	10.3x	→	23:	10.6x	↑	25:	10.2x	→	26:	10.6x	↗	Serie		52.4	Total		0.0	<p>60 Skott</p> 	<table border="1" style="width:100%; border-collapse: collapse;"> <tr><td>1:</td><td>10.6x</td><td>↖</td></tr> <tr><td>2:</td><td>10.6x</td><td>↖</td></tr> <tr><td>3:</td><td>10.6x</td><td>↗</td></tr> <tr><td>4:</td><td>10.6x</td><td>→</td></tr> <tr><td>5:</td><td>10.4x</td><td>↗</td></tr> <tr><td>6:</td><td>10.2x</td><td>↗</td></tr> <tr><td>7:</td><td>10.6x</td><td>←</td></tr> <tr><td>8:</td><td>10.6x</td><td>↓</td></tr> <tr><td>9:</td><td>10.2x</td><td>→</td></tr> <tr><td>10:</td><td>10.6x</td><td>↑</td></tr> <tr><td colspan="2">Serie</td><td style="text-align: right;">105.0</td></tr> <tr><td colspan="2">Total</td><td style="text-align: right;">105.0</td></tr> </table>	1:	10.6x	↖	2:	10.6x	↖	3:	10.6x	↗	4:	10.6x	→	5:	10.4x	↗	6:	10.2x	↗	7:	10.6x	←	8:	10.6x	↓	9:	10.2x	→	10:	10.6x	↑	Serie		105.0	Total		105.0															
21:	10.7x	↖																																																																									
22:	10.3x	→																																																																									
23:	10.6x	↑																																																																									
25:	10.2x	→																																																																									
26:	10.6x	↗																																																																									
Serie		52.4																																																																									
Total		0.0																																																																									
1:	10.6x	↖																																																																									
2:	10.6x	↖																																																																									
3:	10.6x	↗																																																																									
4:	10.6x	→																																																																									
5:	10.4x	↗																																																																									
6:	10.2x	↗																																																																									
7:	10.6x	←																																																																									
8:	10.6x	↓																																																																									
9:	10.2x	→																																																																									
10:	10.6x	↑																																																																									
Serie		105.0																																																																									
Total		105.0																																																																									
<p>60 Skott</p> 	<table border="1" style="width:100%; border-collapse: collapse;"> <tr><td>11:</td><td>10.7x</td><td>→</td></tr> <tr><td>12:</td><td>10.8x</td><td>↑</td></tr> <tr><td>13:</td><td>10.3x</td><td>↑</td></tr> <tr><td>14:</td><td>10.6x</td><td>→</td></tr> <tr><td>15:</td><td>10.7x</td><td>↗</td></tr> <tr><td>16:</td><td>10.3x</td><td>↓</td></tr> <tr><td>17:</td><td>10.7x</td><td>↓</td></tr> <tr><td>18:</td><td>10.5x</td><td>↖</td></tr> <tr><td>19:</td><td>10.5x</td><td>→</td></tr> <tr><td>20:</td><td>10.9x</td><td>→</td></tr> <tr><td colspan="2">Serie</td><td style="text-align: right;">106.0</td></tr> <tr><td colspan="2">Total</td><td style="text-align: right;">211.0</td></tr> </table>	11:	10.7x	→	12:	10.8x	↑	13:	10.3x	↑	14:	10.6x	→	15:	10.7x	↗	16:	10.3x	↓	17:	10.7x	↓	18:	10.5x	↖	19:	10.5x	→	20:	10.9x	→	Serie		106.0	Total		211.0	<p>60 Skott</p> 	<table border="1" style="width:100%; border-collapse: collapse;"> <tr><td>21:</td><td>10.1</td><td>→</td></tr> <tr><td>22:</td><td>10.4x</td><td>↑</td></tr> <tr><td>23:</td><td>10.6x</td><td>↖</td></tr> <tr><td>24:</td><td>10.6x</td><td>↖</td></tr> <tr><td>25:</td><td>10.8x</td><td>↗</td></tr> <tr><td>26:</td><td>10.7x</td><td>→</td></tr> <tr><td>27:</td><td>10.6x</td><td>↓</td></tr> <tr><td>28:</td><td>10.5x</td><td>↑</td></tr> <tr><td>29:</td><td>10.6x</td><td>↓</td></tr> <tr><td>30:</td><td>10.7x</td><td>↑</td></tr> <tr><td colspan="2">Serie</td><td style="text-align: right;">105.6</td></tr> <tr><td colspan="2">Total</td><td style="text-align: right;">316.6</td></tr> </table>	21:	10.1	→	22:	10.4x	↑	23:	10.6x	↖	24:	10.6x	↖	25:	10.8x	↗	26:	10.7x	→	27:	10.6x	↓	28:	10.5x	↑	29:	10.6x	↓	30:	10.7x	↑	Serie		105.6	Total		316.6
11:	10.7x	→																																																																									
12:	10.8x	↑																																																																									
13:	10.3x	↑																																																																									
14:	10.6x	→																																																																									
15:	10.7x	↗																																																																									
16:	10.3x	↓																																																																									
17:	10.7x	↓																																																																									
18:	10.5x	↖																																																																									
19:	10.5x	→																																																																									
20:	10.9x	→																																																																									
Serie		106.0																																																																									
Total		211.0																																																																									
21:	10.1	→																																																																									
22:	10.4x	↑																																																																									
23:	10.6x	↖																																																																									
24:	10.6x	↖																																																																									
25:	10.8x	↗																																																																									
26:	10.7x	→																																																																									
27:	10.6x	↓																																																																									
28:	10.5x	↑																																																																									
29:	10.6x	↓																																																																									
30:	10.7x	↑																																																																									
Serie		105.6																																																																									
Total		316.6																																																																									
<p>60 Skott</p> 	<table border="1" style="width:100%; border-collapse: collapse;"> <tr><td>31:</td><td>10.4x</td><td>↓</td></tr> <tr><td>32:</td><td>10.5x</td><td>↓</td></tr> <tr><td>33:</td><td>10.5x</td><td>↗</td></tr> <tr><td>34:</td><td>10.8x</td><td>↑</td></tr> <tr><td>35:</td><td>10.6x</td><td>↑</td></tr> <tr><td>36:</td><td>10.2x</td><td>↗</td></tr> <tr><td>37:</td><td>10.2x</td><td>↗</td></tr> <tr><td>38:</td><td>10.5x</td><td>↓</td></tr> <tr><td>39:</td><td>10.7x</td><td>↓</td></tr> <tr><td>40:</td><td>10.8x</td><td>↓</td></tr> <tr><td colspan="2">Serie</td><td style="text-align: right;">105.2</td></tr> <tr><td colspan="2">Total</td><td style="text-align: right;">421.8</td></tr> </table>	31:	10.4x	↓	32:	10.5x	↓	33:	10.5x	↗	34:	10.8x	↑	35:	10.6x	↑	36:	10.2x	↗	37:	10.2x	↗	38:	10.5x	↓	39:	10.7x	↓	40:	10.8x	↓	Serie		105.2	Total		421.8																																						
31:	10.4x	↓																																																																									
32:	10.5x	↓																																																																									
33:	10.5x	↗																																																																									
34:	10.8x	↑																																																																									
35:	10.6x	↑																																																																									
36:	10.2x	↗																																																																									
37:	10.2x	↗																																																																									
38:	10.5x	↓																																																																									
39:	10.7x	↓																																																																									
40:	10.8x	↓																																																																									
Serie		105.2																																																																									
Total		421.8																																																																									

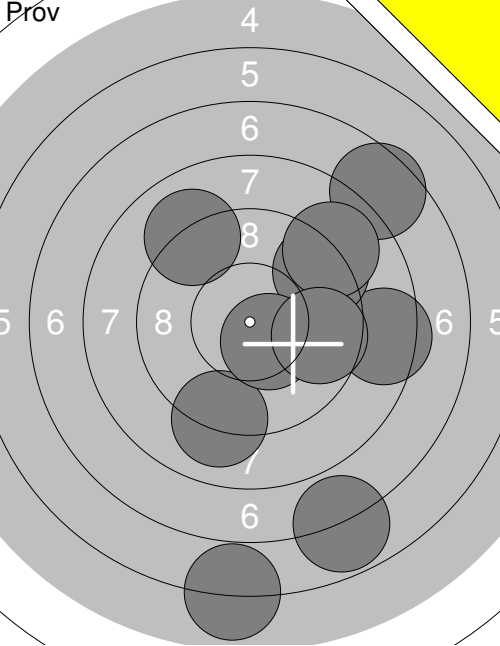
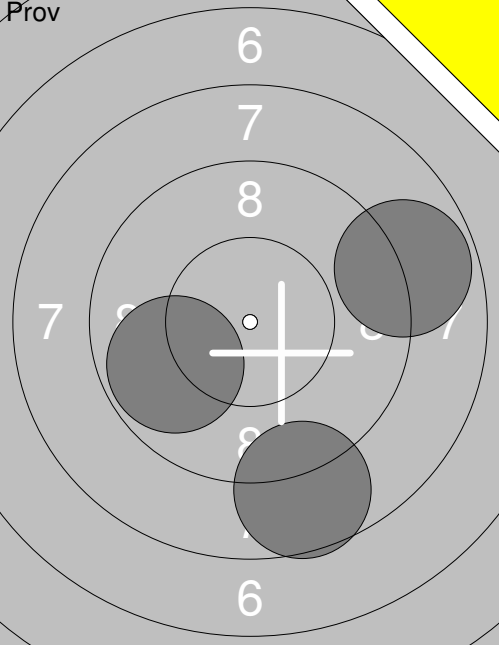
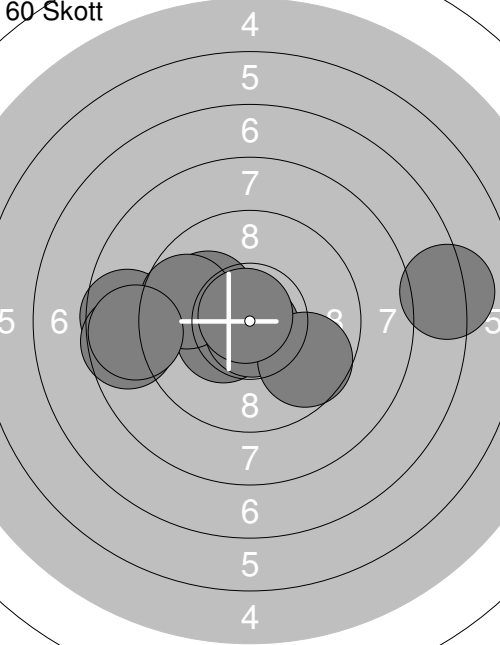
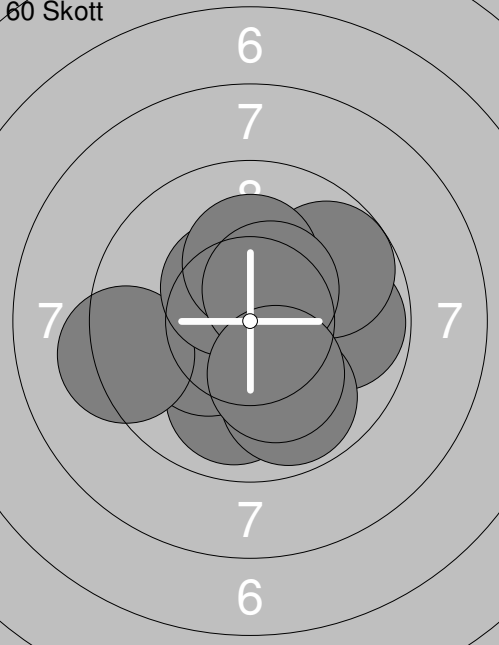
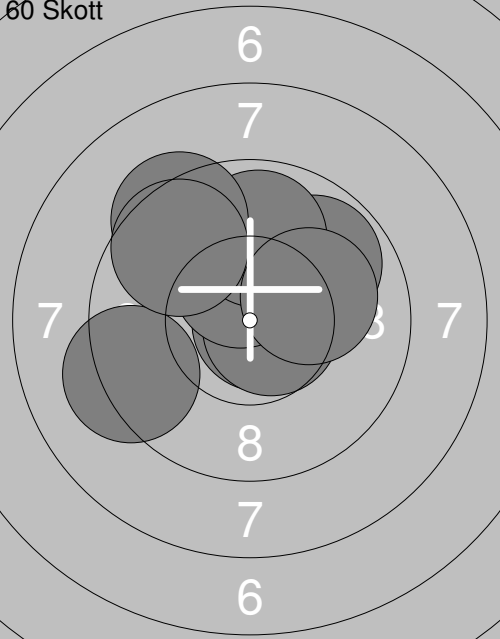
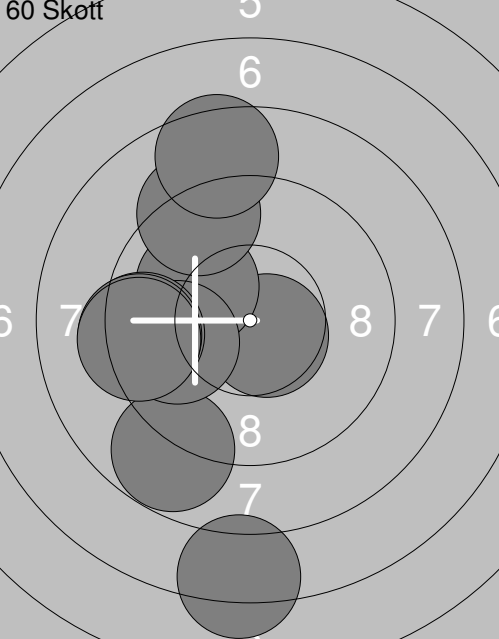
Skjutlag	Tavla	Jan Olov Jonsson	
1	40	Umeå	
S			
25.02.2017	Vännästräffen 2017	Umeå skytteallians	
Pröv		1: 6.8 ↘ 2: 8.4 → 3: 9.1 ↓ 4: 9.3 ↗ 5: 7.6 ↗ 6: 5.9 ↓ 7: 8.9 ↗ 8: 9.1 ↖ 9: 10.4x ↘ 10: 9.6 → Serie 85.1 Total 0.0	Pröv  11: 8.8 → 12: 9.8 ↙ 13: 8.7 ↓ Serie 27.3 Total 0.0
60 Skott		1: 10.1 ↙ 2: 10.4x ↙ 3: 7.2 → 4: 8.6 ← 5: 9.7 ← 6: 10.8x ↓ 7: 9.7 ↘ 8: 10.8x ↘ 9: 8.6 ← 10: 8.8 ← Serie 94.7 Total 94.7	60 Skott  11: 10.0 ↓ 12: 10.3x ↙ 13: 9.3 ← 14: 9.8 → 15: 9.8 ↗ 16: 10.4x ↘ 17: 10.2x ↑ 18: 10.5x ↗ 19: 9.8 ↓ 20: 10.2x ↓ Serie 100.3 Total 195.0
60 Skott		21: 10.8x ⇒ 22: 9.3 ← 23: 10.6x ↗ 24: 10.7x ⇒ 25: 9.8 ↗ 26: 10.4x ↑ 27: 9.9 ↑ 28: 9.4 ↖ 29: 9.6 ↖ 30: 10.1 → Serie 100.6 Total 295.6	60 Skott  31: 10.6x ↘ 32: 10.0 ↙ 33: 8.8 ↓ 34: 7.2 ↓ 35: 9.2 ↖ 36: 8.5 ↑ 37: 9.8 ← 38: 9.4 ← 39: 9.3 ← 40: 9.3 ← Serie 92.1 Total 387.7

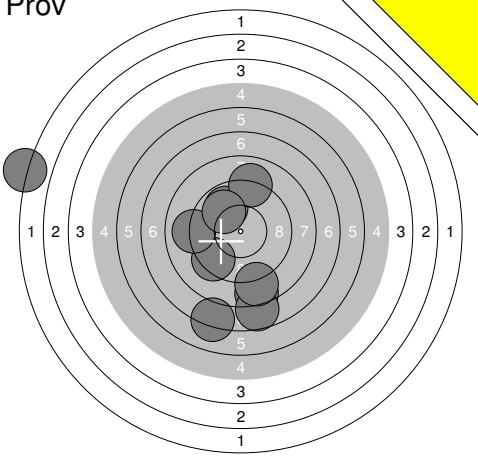
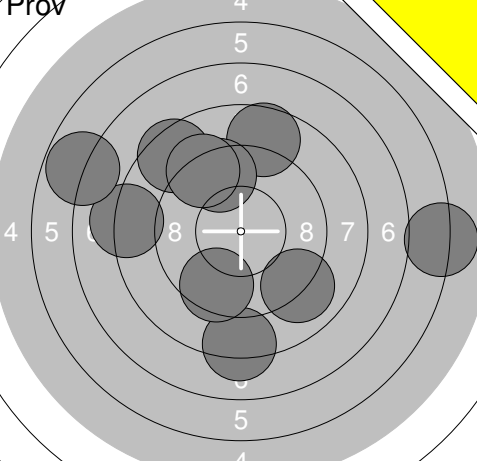
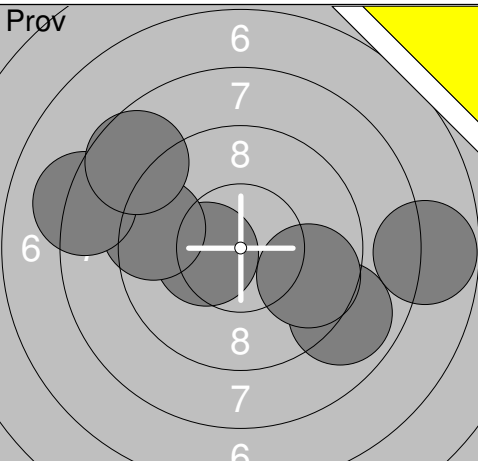
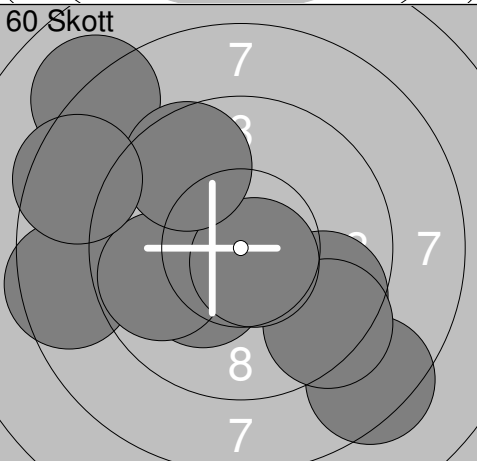
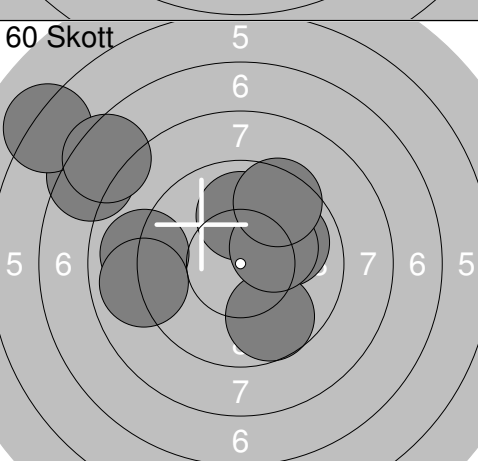
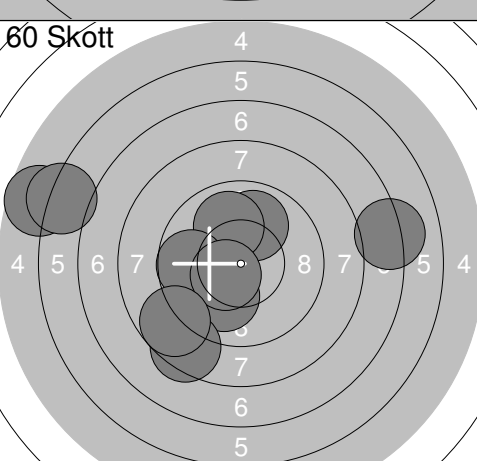
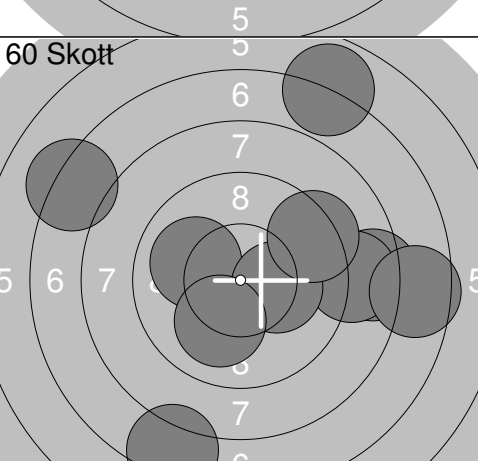
Skjutlag 2	Tavla 3	Jonathan Sundström	
S		Rönnskär	
25.02.2017		Vännästräffen 2017	
Prov		Umeå skytteallians	
	1: 8.3 ↓ 2: 7.7 ↓ 3: 8.7 ↓ 4: 7.1 ↓ 5: 9.4 ↓ 6: 9.0 ← 7: 9.8 ↗ 8: 9.0 ↗ 9: 1.8 ← 10: 9.9 ↗ Serie 80.7 Total 0.0		11: 8.2 ↓ 12: 9.5 ↓ 13: 6.1 → 14: 9.0 ↓ 15: 8.2 ← 16: 8.5 ↗ 17: 8.7 ↗ 18: 6.8 ← 19: 9.5 ↗ 20: 9.2 ↗ Serie 83.7 Total 0.0
	21: 8.9 ↓ 22: 10.4x ← 23: 9.4 ← 24: 9.7 ↗ 25: 8.2 ↗ 26: 7.8 → 27: 8.6 ↗ Serie 63.0 Total 0.0		1: 8.4 ↓ 2: 8.1 ↗ 3: 9.6 ↓ 4: 8.5 ← 5: 9.4 ↓ 6: 10.2x ↓ 7: 9.8 ← 8: 10.7x ↓ 9: 9.6 ↗ 10: 8.5 ↗ Serie 92.8 Total 92.8
	11: 9.9 ↗ 12: 9.0 ← 13: 9.7 ↓ 14: 7.4 ↗ 15: 10.0 ↗ 16: 9.0 ← 17: 10.2x ↗ 18: 6.2 ↗ 19: 7.5 ↗ 20: 9.5 ↗ Serie 88.4 Total 181.2		21: 10.0 ↓ 22: 10.0 ↗ 23: 5.7 ← 24: 10.0 ↗ 25: 8.4 ↓ 26: 9.7 ← 27: 7.1 → 28: 6.2 ← 29: 10.5x ↓ 30: 8.8 ↓ Serie 86.4 Total 267.6
	31: 7.4 ↓ 32: 8.4 → 33: 10.0 ↗ 34: 8.8 → 35: 10.2x → 36: 7.2 ↗ 37: 6.9 ↗ 38: 9.3 ↗ 39: 10.1 ↓ 40: 7.6 → Serie 85.9 Total 353.5		

<p>Prov</p>	<table border="1" style="width:100%; border-collapse: collapse;"> <tr><td>1:</td><td>9.6</td><td>↙</td></tr> <tr><td>2:</td><td>7.9</td><td>↘</td></tr> <tr><td>3:</td><td>9.2</td><td>↘</td></tr> <tr><td>4:</td><td>8.2</td><td>→</td></tr> <tr><td>5:</td><td>7.5</td><td>↙</td></tr> <tr><td>6:</td><td>9.0</td><td>→</td></tr> <tr><td>7:</td><td>9.1</td><td>↙</td></tr> <tr><td>8:</td><td>9.2</td><td>↙</td></tr> <tr><td>9:</td><td>7.5</td><td>→</td></tr> <tr><td>10:</td><td>8.6</td><td>↙</td></tr> <tr><td colspan="2">Serie</td><td>85.8</td></tr> <tr><td colspan="2">Total</td><td>0.0</td></tr> </table>	1:	9.6	↙	2:	7.9	↘	3:	9.2	↘	4:	8.2	→	5:	7.5	↙	6:	9.0	→	7:	9.1	↙	8:	9.2	↙	9:	7.5	→	10:	8.6	↙	Serie		85.8	Total		0.0	<p>Prov</p>	<table border="1" style="width:100%; border-collapse: collapse;"> <tr><td>11:</td><td>7.3</td><td>↘</td></tr> <tr><td>12:</td><td>9.9</td><td>↘</td></tr> <tr><td>13:</td><td>8.6</td><td>→</td></tr> <tr><td>14:</td><td>8.1</td><td>→</td></tr> <tr><td>15:</td><td>9.7</td><td>→</td></tr> <tr><td>16:</td><td>8.9</td><td>→</td></tr> <tr><td>17:</td><td>9.0</td><td>↙</td></tr> <tr><td>18:</td><td>10.1</td><td>↑</td></tr> <tr><td>19:</td><td>9.1</td><td>→</td></tr> <tr><td>20:</td><td>7.7</td><td>↙</td></tr> <tr><td colspan="2">Serie</td><td>88.4</td></tr> <tr><td colspan="2">Total</td><td>0.0</td></tr> </table>	11:	7.3	↘	12:	9.9	↘	13:	8.6	→	14:	8.1	→	15:	9.7	→	16:	8.9	→	17:	9.0	↙	18:	10.1	↑	19:	9.1	→	20:	7.7	↙	Serie		88.4	Total		0.0
1:	9.6	↙																																																																									
2:	7.9	↘																																																																									
3:	9.2	↘																																																																									
4:	8.2	→																																																																									
5:	7.5	↙																																																																									
6:	9.0	→																																																																									
7:	9.1	↙																																																																									
8:	9.2	↙																																																																									
9:	7.5	→																																																																									
10:	8.6	↙																																																																									
Serie		85.8																																																																									
Total		0.0																																																																									
11:	7.3	↘																																																																									
12:	9.9	↘																																																																									
13:	8.6	→																																																																									
14:	8.1	→																																																																									
15:	9.7	→																																																																									
16:	8.9	→																																																																									
17:	9.0	↙																																																																									
18:	10.1	↑																																																																									
19:	9.1	→																																																																									
20:	7.7	↙																																																																									
Serie		88.4																																																																									
Total		0.0																																																																									
<p>Prov</p>	<table border="1" style="width:100%; border-collapse: collapse;"> <tr><td>21:</td><td>9.2</td><td>↘</td></tr> <tr><td>22:</td><td>7.3</td><td>↘</td></tr> <tr><td colspan="2">Serie</td><td>16.5</td></tr> <tr><td colspan="2">Total</td><td>0.0</td></tr> </table>	21:	9.2	↘	22:	7.3	↘	Serie		16.5	Total		0.0	<p>60 Skott</p>	<table border="1" style="width:100%; border-collapse: collapse;"> <tr><td>1:</td><td>9.7</td><td>→</td></tr> <tr><td>2:</td><td>9.1</td><td>↙</td></tr> <tr><td>3:</td><td>8.9</td><td>↙</td></tr> <tr><td>4:</td><td>9.0</td><td>↑</td></tr> <tr><td>5:</td><td>8.6</td><td>↙</td></tr> <tr><td>6:</td><td>5.5</td><td>↙</td></tr> <tr><td>7:</td><td>7.6</td><td>→</td></tr> <tr><td>8:</td><td>9.1</td><td>→</td></tr> <tr><td>9:</td><td>7.6</td><td>↙</td></tr> <tr><td>10:</td><td>8.4</td><td>→</td></tr> <tr><td colspan="2">Serie</td><td>83.5</td></tr> <tr><td colspan="2">Total</td><td>83.5</td></tr> </table>	1:	9.7	→	2:	9.1	↙	3:	8.9	↙	4:	9.0	↑	5:	8.6	↙	6:	5.5	↙	7:	7.6	→	8:	9.1	→	9:	7.6	↙	10:	8.4	→	Serie		83.5	Total		83.5																								
21:	9.2	↘																																																																									
22:	7.3	↘																																																																									
Serie		16.5																																																																									
Total		0.0																																																																									
1:	9.7	→																																																																									
2:	9.1	↙																																																																									
3:	8.9	↙																																																																									
4:	9.0	↑																																																																									
5:	8.6	↙																																																																									
6:	5.5	↙																																																																									
7:	7.6	→																																																																									
8:	9.1	→																																																																									
9:	7.6	↙																																																																									
10:	8.4	→																																																																									
Serie		83.5																																																																									
Total		83.5																																																																									
<p>60 Skott</p>	<table border="1" style="width:100%; border-collapse: collapse;"> <tr><td>11:</td><td>9.3</td><td>→</td></tr> <tr><td>12:</td><td>7.3</td><td>↘</td></tr> <tr><td>13:</td><td>8.7</td><td>↘</td></tr> <tr><td>14:</td><td>8.4</td><td>→</td></tr> <tr><td>15:</td><td>7.7</td><td>→</td></tr> <tr><td>16:</td><td>7.5</td><td>↘</td></tr> <tr><td>17:</td><td>7.7</td><td>↘</td></tr> <tr><td>18:</td><td>8.9</td><td>↘</td></tr> <tr><td>19:</td><td>9.5</td><td>←</td></tr> <tr><td>20:</td><td>9.9</td><td>↙</td></tr> <tr><td colspan="2">Serie</td><td>84.9</td></tr> <tr><td colspan="2">Total</td><td>168.4</td></tr> </table>	11:	9.3	→	12:	7.3	↘	13:	8.7	↘	14:	8.4	→	15:	7.7	→	16:	7.5	↘	17:	7.7	↘	18:	8.9	↘	19:	9.5	←	20:	9.9	↙	Serie		84.9	Total		168.4	<p>60 Skott</p>	<table border="1" style="width:100%; border-collapse: collapse;"> <tr><td>21:</td><td>9.0</td><td>←</td></tr> <tr><td>22:</td><td>8.8</td><td>←</td></tr> <tr><td>23:</td><td>10.2x</td><td>←</td></tr> <tr><td>24:</td><td>9.8</td><td>↙</td></tr> <tr><td>25:</td><td>9.9</td><td>→</td></tr> <tr><td>26:</td><td>7.6</td><td>↙</td></tr> <tr><td>27:</td><td>8.4</td><td>↙</td></tr> <tr><td>28:</td><td>8.1</td><td>↙</td></tr> <tr><td>29:</td><td>7.6</td><td>→</td></tr> <tr><td>30:</td><td>8.0</td><td>→</td></tr> <tr><td colspan="2">Serie</td><td>87.4</td></tr> <tr><td colspan="2">Total</td><td>255.8</td></tr> </table>	21:	9.0	←	22:	8.8	←	23:	10.2x	←	24:	9.8	↙	25:	9.9	→	26:	7.6	↙	27:	8.4	↙	28:	8.1	↙	29:	7.6	→	30:	8.0	→	Serie		87.4	Total		255.8
11:	9.3	→																																																																									
12:	7.3	↘																																																																									
13:	8.7	↘																																																																									
14:	8.4	→																																																																									
15:	7.7	→																																																																									
16:	7.5	↘																																																																									
17:	7.7	↘																																																																									
18:	8.9	↘																																																																									
19:	9.5	←																																																																									
20:	9.9	↙																																																																									
Serie		84.9																																																																									
Total		168.4																																																																									
21:	9.0	←																																																																									
22:	8.8	←																																																																									
23:	10.2x	←																																																																									
24:	9.8	↙																																																																									
25:	9.9	→																																																																									
26:	7.6	↙																																																																									
27:	8.4	↙																																																																									
28:	8.1	↙																																																																									
29:	7.6	→																																																																									
30:	8.0	→																																																																									
Serie		87.4																																																																									
Total		255.8																																																																									
<p>60 Skott</p>	<table border="1" style="width:100%; border-collapse: collapse;"> <tr><td>31:</td><td>8.2</td><td>↙</td></tr> <tr><td>32:</td><td>7.5</td><td>↙</td></tr> <tr><td>33:</td><td>9.3</td><td>↘</td></tr> <tr><td>34:</td><td>7.7</td><td>↘</td></tr> <tr><td>35:</td><td>6.6</td><td>↙</td></tr> <tr><td>36:</td><td>9.8</td><td>↗</td></tr> <tr><td>37:</td><td>7.9</td><td>→</td></tr> <tr><td>38:</td><td>8.8</td><td>→</td></tr> <tr><td>39:</td><td>9.3</td><td>←</td></tr> <tr><td>40:</td><td>8.1</td><td>↙</td></tr> <tr><td colspan="2">Serie</td><td>83.2</td></tr> <tr><td colspan="2">Total</td><td>339.0</td></tr> </table>	31:	8.2	↙	32:	7.5	↙	33:	9.3	↘	34:	7.7	↘	35:	6.6	↙	36:	9.8	↗	37:	7.9	→	38:	8.8	→	39:	9.3	←	40:	8.1	↙	Serie		83.2	Total		339.0																																						
31:	8.2	↙																																																																									
32:	7.5	↙																																																																									
33:	9.3	↘																																																																									
34:	7.7	↘																																																																									
35:	6.6	↙																																																																									
36:	9.8	↗																																																																									
37:	7.9	→																																																																									
38:	8.8	→																																																																									
39:	9.3	←																																																																									
40:	8.1	↙																																																																									
Serie		83.2																																																																									
Total		339.0																																																																									

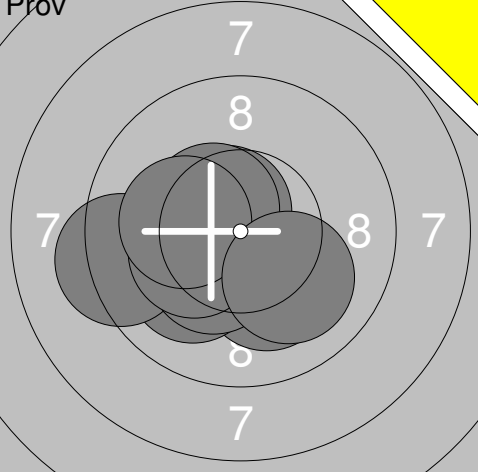
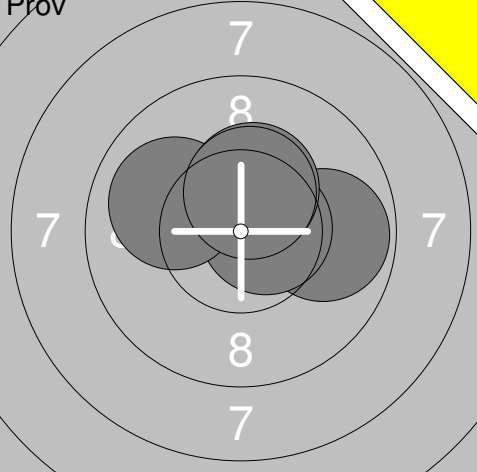
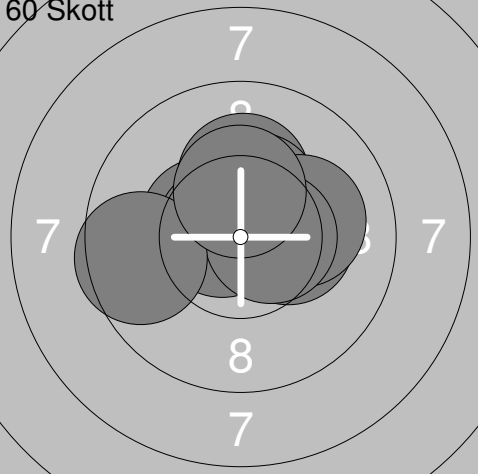
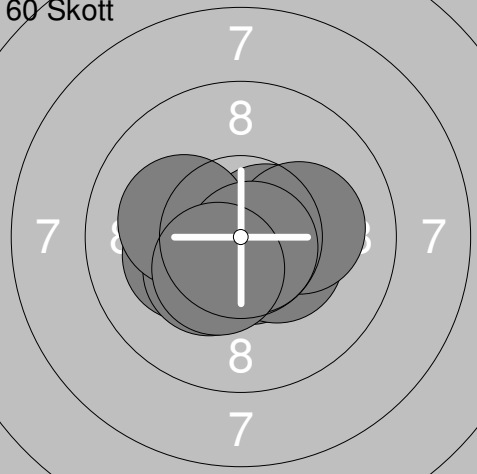
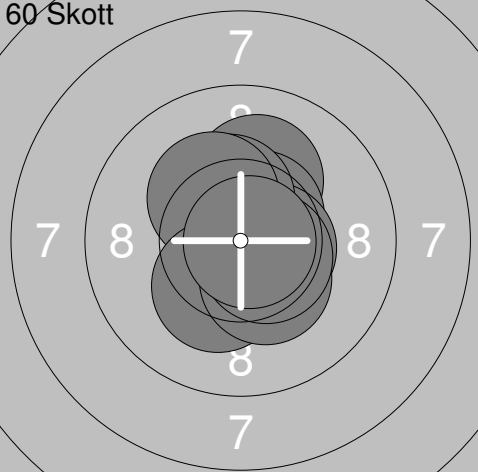
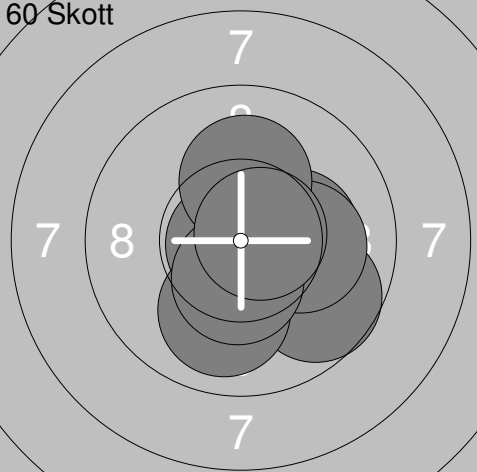
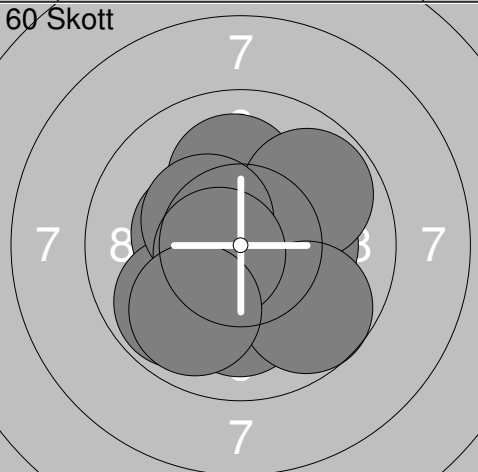
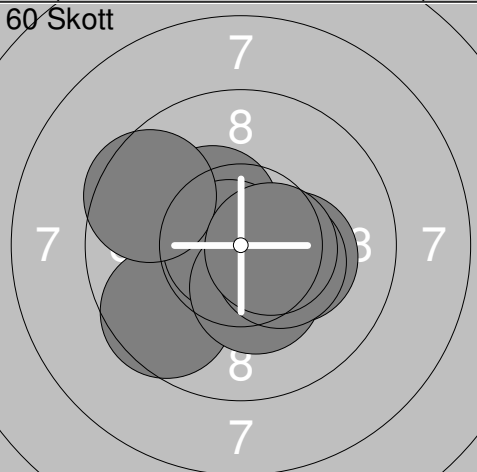
<p>Pröv</p> 	<p>1: 10.2x ↘ 2: 10.1 ↙ 3: 9.3 ← 4: 10.3x ↙ 5: 10.4x ← 6: 10.6x ↗ 7: 10.3x ← 8: 10.5x ↗ 9: 10.2x ← 10: 10.1 ↘</p> <p>Serie 102.0 Total 0.0</p>	<p>Pröv</p> 	<p>11: 9.8 → 12: 10.6x → 13: 10.0 ↖ 14: 10.4x ↗ 15: 10.4x ↗</p> <p>Serie 51.2 Total 0.0</p>
<p>60 Skott</p> 	<p>1: 10.3x → 2: 10.2x ↑ 3: 10.4x ↖ 4: 10.2x ↑ 5: 10.7x ↖ 6: 10.4x ↗ 7: 10.1 → 8: 10.5x → 9: 9.6 ← 10: 10.3x ↑</p> <p>Serie 102.7 Total 102.7</p>	<p>60 Skott</p> 	<p>11: 10.6x ↘ 12: 10.6x → 13: 10.4x ↘ 14: 10.2x ← 15: 10.5x ↘ 16: 10.3x ↘ 17: 10.2x ← 18: 10.2x → 19: 10.8x ↘ 20: 10.4x ↘</p> <p>Serie 104.2 Total 206.9</p>
<p>60 Skott</p> 	<p>21: 10.4x ↑ 22: 10.1 ↑ 23: 10.6x ↗ 24: 10.5x → 25: 10.4x ↗ 26: 10.3x ↗ 27: 10.3x ↘ 28: 10.3x ↘ 29: 10.5x ↘ 30: 10.8x →</p> <p>Serie 104.2 Total 311.1</p>	<p>60 Skott</p> 	<p>31: 10.2x → 32: 10.1 ↘ 33: 10.6x ↘ 34: 10.8x ← 35: 9.7 ↘ 36: 10.1 → 37: 10.2x ↑ 38: 10.0 ↘ 39: 10.4x ↘ 40: 10.7x →</p> <p>Serie 102.8 Total 413.9</p>
<p>60 Skott</p> 	<p>41: 10.4x ↖ 42: 10.3x → 43: 10.1 ↘ 44: 9.8 ↘ 45: 10.1 ↑ 46: 9.8 ↗ 47: 10.4x ↗ 48: 9.7 ↘ 49: 10.6x ← 50: 9.9 ↘</p> <p>Serie 101.1 Total 515.0</p>	<p>60 Skott</p> 	<p>51: 10.4x ↗ 52: 10.2x → 53: 10.4x ↖ 54: 10.5x ↘ 55: 9.6 ↘ 56: 10.8x ← 57: 10.3x ↘ 58: 10.4x ↘ 59: 9.6 ↖ 60: 10.5x →</p> <p>Serie 102.7 Total 617.7</p>

<p>Prov</p>	<p>1: 10.1 ←</p> <p>2: 9.0 ↙</p> <p>3: 8.8 →</p> <p>4: 9.9 ↑</p> <p>5: 9.3 ↑</p> <p>6: 8.2 →</p> <p>7: 9.6 ↓</p> <p>8: 10.6 ✕</p> <p>9: 9.5 ↗</p> <p>10: 10.1 ↑</p> <hr/> <p>Serie 95.1</p> <p>Total 0.0</p>	<p>Prov</p>	<p>11: 10.0 ↗</p> <p>12: 10.1 ↑</p> <p>13: 10.0 →</p> <p>14: 8.9 ↑</p> <p>15: 10.4 ✕</p> <hr/> <p>Serie 49.4</p> <p>Total 0.0</p>
-------------	--	-------------	---

<p>60 Skott</p>	<p>1: 10.4 ✕</p> <p>2: 10.0 ↙</p> <p>3: 10.1 ↗</p> <p>4: 10.1 ↑</p> <p>5: 10.0 ↗</p> <p>6: 10.7 ✕</p> <p>7: 10.7 ✕</p> <p>8: 9.1 ↓</p> <p>9: 9.4 →</p> <p>10: 9.2 ←</p> <hr/> <p>Serie 99.7</p> <p>Total 99.7</p>	<p>60 Skott</p>	<p>11: 7.8 →</p> <p>12: 10.3 ✕</p> <p>13: 8.8 →</p> <p>14: 9.7 ↑</p> <p>15: 9.7 ←</p> <p>16: 9.5 ↗</p> <p>17: 8.4 →</p> <p>18: 9.3 ←</p> <p>19: 10.3 ✕</p> <p>20: 9.3 ↙</p> <hr/> <p>Serie 93.1</p> <p>Total 192.8</p>
-----------------	---	-----------------	--

<p>60 Skott</p>	<p>21: 9.4 ↗</p> <p>22: 9.2 ↑</p> <p>23: 9.9 ↙</p> <p>24: 9.7 →</p> <p>25: 9.2 ←</p> <p>26: 9.8 ↓</p> <p>27: 9.5 ↗</p> <p>28: 9.6 ←</p> <p>29: 9.3 ↓</p> <p>30: 10.1 ↓</p> <hr/> <p>Serie 95.7</p> <p>Total 288.5</p>	<p>60 Skott</p>	<p>31: 8.5 ↘</p> <p>32: 9.9 ↗</p> <p>33: 10.4 ✕</p> <p>34: 10.4 ✕</p> <p>35: 10.1 ←</p> <p>36: 9.8 ↓</p> <p>37: 8.9 ↓</p> <p>38: 8.1 ↖</p> <p>39: 9.3 ↑</p> <p>40: 8.7 ↓</p> <hr/> <p>Serie 94.1</p> <p>Total 382.6</p>
-----------------	---	-----------------	---

<p>Prov</p>	<p>1: 9.9 ↘ 2: 10.7x↓ 3: 10.3x↖ 4: 10.3x→ 5: 10.0 ↑ 6: 10.1 → 7: 10.2x↖ 8: 10.4x→ 9: 10.8x→ 10: 9.6 ↘</p> <p>Serie 102.3 Total 0.0</p>	<p>Prov</p>	<p>11: 9.7 → 12: 9.1 → 13: 10.0 → 14: 9.9 ↙ 16: 10.5x↖ 17: 10.4x↙ 18: 10.2x↖</p> <p>Serie 69.8 Total 0.0</p>
<p>60 Skott</p>	<p>1: 9.5 ↖ 2: 10.2x↖ 3: 10.1 ↗ 4: 9.4 ↘ 5: 10.8x↗ 6: 10.6x→ 7: 10.8x↗ 8: 9.8 ↘ 9: 10.9x↖ 10: 10.1 ↘</p> <p>Serie 102.2 Total 102.2</p>	<p>60 Skott</p>	<p>11: 10.5x→ 12: 9.8 ↙ 13: 10.8x↖ 14: 10.7x↘ 15: 10.6x↙ 16: 10.7x↓ 17: 9.8 → 18: 9.5 ← 19: 10.4x↖ 20: 10.3x↙</p> <p>Serie 103.1 Total 205.3</p>
<p>60 Skott</p>	<p>21: 10.4x↙ 22: 10.3x→ 23: 9.6 → 24: 10.8x↓ 25: 10.2x↘ 26: 9.5 → 27: 10.8x↓ 28: 10.3x↘ 29: 10.1 → 30: 10.9x↓</p> <p>Serie 102.9 Total 308.2</p>	<p>60 Skott</p>	<p>31: 10.8x↘ 32: 10.5x↘ 33: 9.4 ← 34: 10.0 → 35: 10.5x→ 36: 10.8x↖ 37: 9.8 ↘ 38: 9.8 → 39: 10.2x↑ 40: 10.0 ←</p> <p>Serie 101.8 Total 410.0</p>

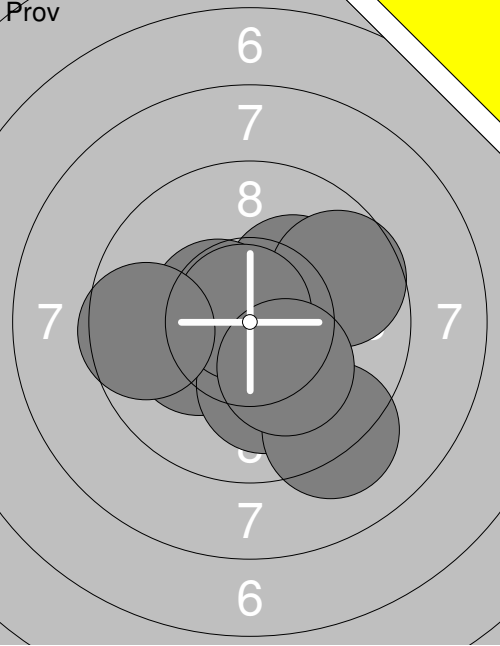
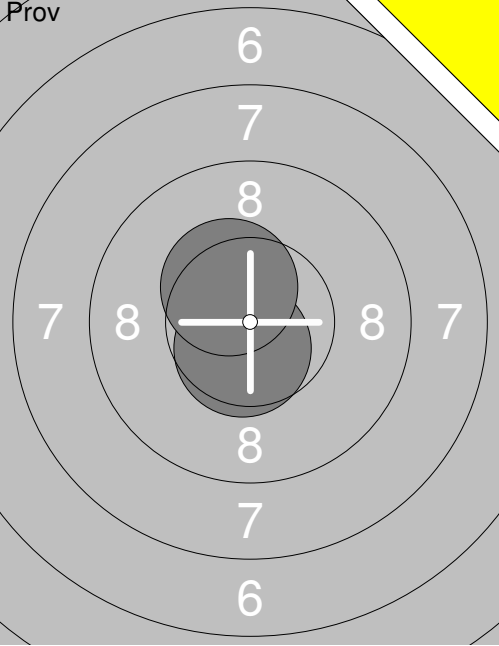
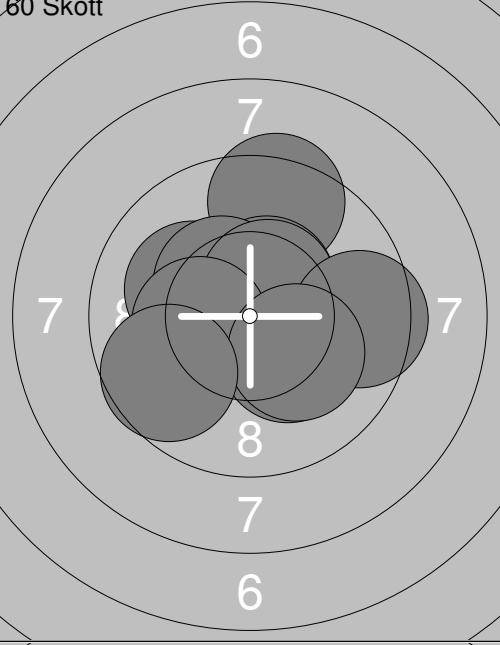
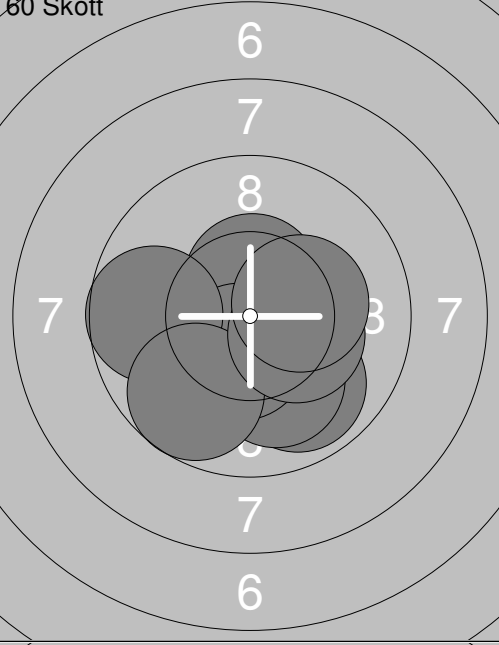
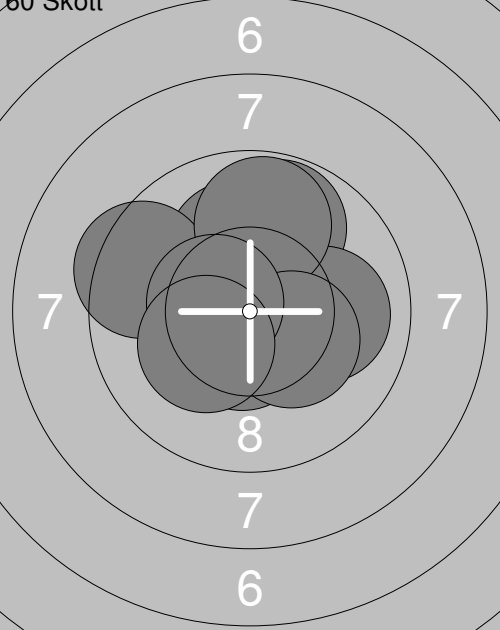
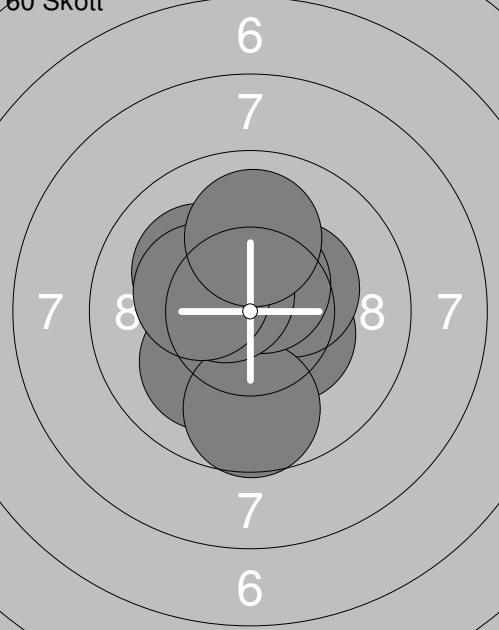
Skjutlag	Tavla	Hanna Lundin	
2	9		
S	Umeå		
25.02.2017	Vännästräffen 2017	Umeå skytteallians	
	1: 10.2x↘ 2: 10.4x→ 3: 10.2x↗ 4: 10.5x↖ 5: 10.1↓ 6: 9.7↗ 7: 10.8x↖ 8: 9.6← 9: 9.2↓ 10: 10.2x↘ Serie 100.9 Total 0.0		11: 10.6x↘ 12: 10.4x↖ Serie 21.0 Total 0.0
	1: 9.4↑ 2: 10.1↖ 3: 10.5x↗ 4: 10.4x↖ 5: 10.3x↘ 6: 10.5x↗ 7: 9.5→ 8: 10.3x↖ 9: 10.2x↘ 10: 9.7↖ Serie 100.9 Total 100.9		11: 10.4x→ 12: 10.7x↘ 13: 10.5x↑ 14: 9.9↓ 15: 10.1↓ 16: 10.5x↘ 17: 9.7← 18: 9.7↓ 19: 10.3x↘ 20: 10.3x→ Serie 102.1 Total 203.0
	21: 10.5x↘ 22: 9.8↑ 23: 10.0→ 24: 10.4x↖ 25: 10.1↑ 26: 9.5↖ 27: 9.8↑ 28: 10.3x↘ 29: 10.5x↖ 30: 10.2x↖ Serie 101.1 Total 304.1		31: 10.4x↘ 32: 10.1↘ 33: 10.3x↗ 34: 10.6x↖ 35: 9.7↓ 36: 10.6x↗ 37: 10.1↖ 38: 10.6x↖ 39: 10.3x↖ 40: 10.0↑ Serie 102.7 Total 406.8

Prov 	1: 6.8 → 2: 9.5 ↗ 3: 8.4 ↓ 4: 10.2x ↗ 5: 9.4 → 6: 9.8 ↗ 7: 9.3 ↓ 8: 10.1 ← 9: 7.1 → 10: 9.5 ↙ <hr/> Serie 90.1 Total 0.0	Prov 	11: 10.2x ↙ 12: 8.0 ↙ 13: 8.4 → 14: 9.3 ↓ 15: 6.9 → 16: 9.6 ↗ 17: 8.4 ↓ 18: 9.1 ↘ 19: 10.0 ↓ 20: 9.7 ↓ <hr/> Serie 89.6 Total 0.0
-----------------	---	-----------------	--

60 Skott 	1: 8.7 ← 2: 7.9 → 3: 8.2 ← 4: 10.1 ↓ 5: 10.7x ↓ 6: 9.7 ↗ 7: 10.1 ↓ 8: 9.1 ↓ 9: 9.4 ↓ 10: 9.8 ↘ <hr/> Serie 93.7 Total 93.7	60 Skott 	11: 10.8x ← 12: 10.8x ↙ 13: 9.0 ↗ 14: 9.8 → 15: 10.0 ↗ 16: 8.9 → 17: 9.5 ↓ 18: 10.0 → 19: 9.8 ↓ 20: 9.1 ↘ <hr/> Serie 97.7 Total 191.4
---------------------	---	---------------------	---

60 Skott 	21: 9.9 ↓ 22: 8.7 → 23: 10.5x ↓ 24: 9.6 ↓ 25: 9.5 ↓ 26: 10.6x ↓ 27: 9.5 ↗ 28: 8.8 → 29: 10.3x ↓ 30: 10.4x ← <hr/> Serie 97.8 Total 289.2	60 Skott 	31: 10.7x ↙ 32: 8.4 → 33: 9.9 ↓ 34: 8.6 ↓ 35: 9.5 ↗ 36: 8.7 → 37: 10.5x ← 38: 10.7x ↓ 39: 10.0 ↗ 40: 6.7 ↓ <hr/> Serie 93.7 Total 382.9
---------------------	---	---------------------	--

60 Skott 	41: 8.9 ↓ 42: 8.5 ← 43: 8.3 ↘ 44: 10.0 ↓ 45: 9.8 → 46: 10.0 ← 47: 10.3x ↗ 48: 10.6x ↗ 49: 9.3 ↘ 50: 9.3 ↗ <hr/> Serie 95.0 Total 477.9	60 Skott 	51: 8.2 ← 52: 10.1 ← 53: 6.3 ↘ 54: 9.5 ↘ 55: 9.0 ↙ 56: 9.7 ↘ 57: 9.5 → 58: 9.2 ↘ 59: 9.3 ↗ 60: 9.5 ↗ <hr/> Serie 90.3 Total 568.2
---------------------	---	---------------------	--

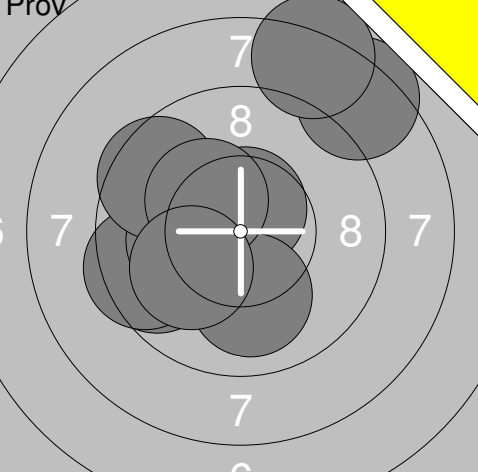
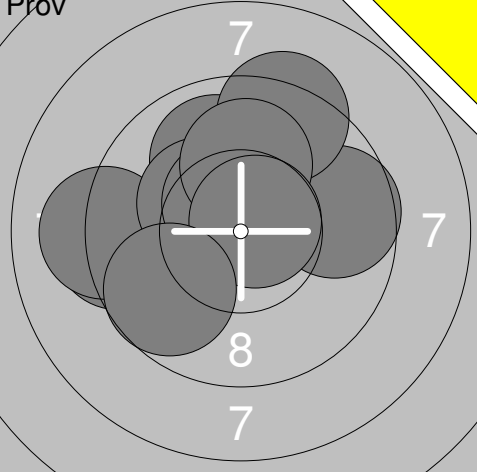
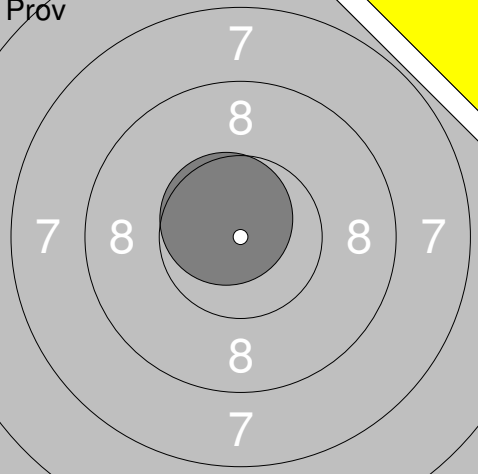
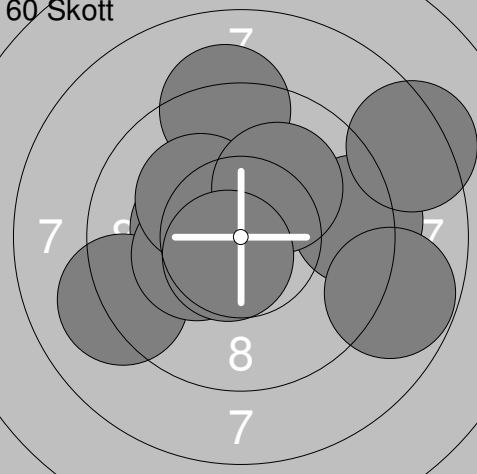
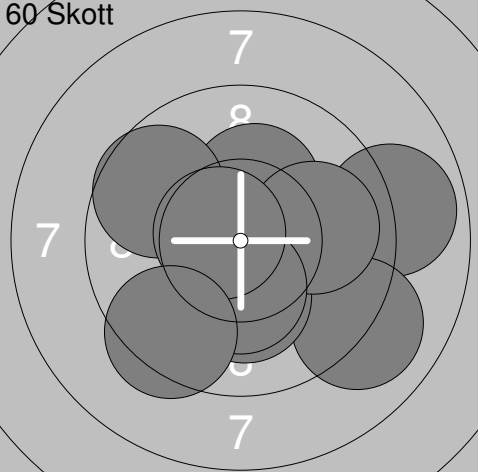
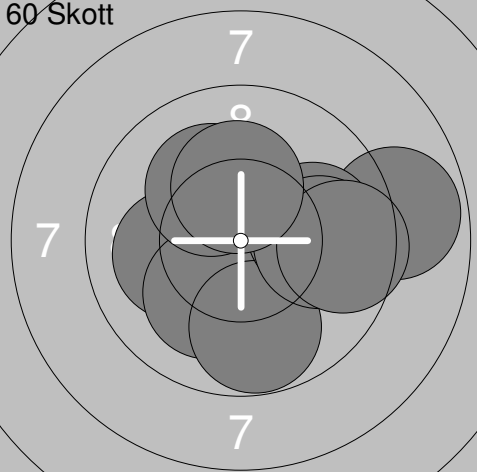
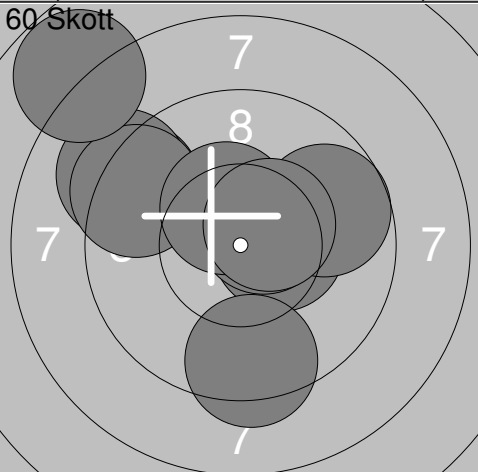
<p>Prov</p> 	<table border="1" style="width:100%; border-collapse: collapse;"> <tr><td>1:</td><td>9.6</td><td>↙</td></tr> <tr><td>2:</td><td>8.4</td><td>↗</td></tr> <tr><td>3:</td><td>10.6x</td><td>↑</td></tr> <tr><td>4:</td><td>9.5</td><td>↙</td></tr> <tr><td>5:</td><td>10.2x</td><td>↙</td></tr> <tr><td>6:</td><td>10.0</td><td>↓</td></tr> <tr><td>7:</td><td>9.5</td><td>↗</td></tr> <tr><td>8:</td><td>8.2</td><td>↗</td></tr> <tr><td>9:</td><td>10.3x</td><td>↗</td></tr> <tr><td>10:</td><td>10.1</td><td>↙</td></tr> <tr><td colspan="2">Serie</td><td>96.4</td></tr> <tr><td colspan="2">Total</td><td>0.0</td></tr> </table>	1:	9.6	↙	2:	8.4	↗	3:	10.6x	↑	4:	9.5	↙	5:	10.2x	↙	6:	10.0	↓	7:	9.5	↗	8:	8.2	↗	9:	10.3x	↗	10:	10.1	↙	Serie		96.4	Total		0.0	<p>Prov</p> 	<table border="1" style="width:100%; border-collapse: collapse;"> <tr><td>11:</td><td>9.3</td><td>↙</td></tr> <tr><td>12:</td><td>9.1</td><td>↙</td></tr> <tr><td>13:</td><td>9.9</td><td>↑</td></tr> <tr><td>14:</td><td>9.7</td><td>→</td></tr> <tr><td>15:</td><td>10.3x</td><td>↗</td></tr> <tr><td>16:</td><td>10.5x</td><td>↗</td></tr> <tr><td>17:</td><td>9.3</td><td>↑</td></tr> <tr><td>18:</td><td>10.0</td><td>↑</td></tr> <tr><td>19:</td><td>10.7x</td><td>↗</td></tr> <tr><td>20:</td><td>9.7</td><td>↙</td></tr> <tr><td colspan="2">Serie</td><td>98.5</td></tr> <tr><td colspan="2">Total</td><td>0.0</td></tr> </table>	11:	9.3	↙	12:	9.1	↙	13:	9.9	↑	14:	9.7	→	15:	10.3x	↗	16:	10.5x	↗	17:	9.3	↑	18:	10.0	↑	19:	10.7x	↗	20:	9.7	↙	Serie		98.5	Total		0.0
1:	9.6	↙																																																																									
2:	8.4	↗																																																																									
3:	10.6x	↑																																																																									
4:	9.5	↙																																																																									
5:	10.2x	↙																																																																									
6:	10.0	↓																																																																									
7:	9.5	↗																																																																									
8:	8.2	↗																																																																									
9:	10.3x	↗																																																																									
10:	10.1	↙																																																																									
Serie		96.4																																																																									
Total		0.0																																																																									
11:	9.3	↙																																																																									
12:	9.1	↙																																																																									
13:	9.9	↑																																																																									
14:	9.7	→																																																																									
15:	10.3x	↗																																																																									
16:	10.5x	↗																																																																									
17:	9.3	↑																																																																									
18:	10.0	↑																																																																									
19:	10.7x	↗																																																																									
20:	9.7	↙																																																																									
Serie		98.5																																																																									
Total		0.0																																																																									
<p>Prov</p> 	<table border="1" style="width:100%; border-collapse: collapse;"> <tr><td>21:</td><td>10.6x</td><td>↗</td></tr> <tr><td colspan="2">Serie</td><td>10.6</td></tr> <tr><td colspan="2">Total</td><td>0.0</td></tr> </table>	21:	10.6x	↗	Serie		10.6	Total		0.0	<p>60 Skott</p> 	<table border="1" style="width:100%; border-collapse: collapse;"> <tr><td>1:</td><td>9.2</td><td>↑</td></tr> <tr><td>2:</td><td>10.3x</td><td>↙</td></tr> <tr><td>3:</td><td>9.1</td><td>↙</td></tr> <tr><td>4:</td><td>10.3x</td><td>↙</td></tr> <tr><td>5:</td><td>10.2x</td><td>↖</td></tr> <tr><td>6:</td><td>9.3</td><td>→</td></tr> <tr><td>7:</td><td>10.1</td><td>↗</td></tr> <tr><td>8:</td><td>8.3</td><td>→</td></tr> <tr><td>9:</td><td>10.6x</td><td>↙</td></tr> <tr><td>10:</td><td>8.8</td><td>→</td></tr> <tr><td colspan="2">Serie</td><td>96.2</td></tr> <tr><td colspan="2">Total</td><td>96.2</td></tr> </table>	1:	9.2	↑	2:	10.3x	↙	3:	9.1	↙	4:	10.3x	↙	5:	10.2x	↖	6:	9.3	→	7:	10.1	↗	8:	8.3	→	9:	10.6x	↙	10:	8.8	→	Serie		96.2	Total		96.2																											
21:	10.6x	↗																																																																									
Serie		10.6																																																																									
Total		0.0																																																																									
1:	9.2	↑																																																																									
2:	10.3x	↙																																																																									
3:	9.1	↙																																																																									
4:	10.3x	↙																																																																									
5:	10.2x	↖																																																																									
6:	9.3	→																																																																									
7:	10.1	↗																																																																									
8:	8.3	→																																																																									
9:	10.6x	↙																																																																									
10:	8.8	→																																																																									
Serie		96.2																																																																									
Total		96.2																																																																									
<p>60 Skott</p> 	<table border="1" style="width:100%; border-collapse: collapse;"> <tr><td>11:</td><td>8.9</td><td>→</td></tr> <tr><td>12:</td><td>10.7x</td><td>↘</td></tr> <tr><td>13:</td><td>9.0</td><td>↘</td></tr> <tr><td>14:</td><td>10.2x</td><td>↓</td></tr> <tr><td>15:</td><td>10.2x</td><td>↑</td></tr> <tr><td>16:</td><td>10.0</td><td>→</td></tr> <tr><td>17:</td><td>9.7</td><td>↗</td></tr> <tr><td>18:</td><td>10.3x</td><td>↓</td></tr> <tr><td>19:</td><td>10.6x</td><td>↗</td></tr> <tr><td>20:</td><td>9.4</td><td>↙</td></tr> <tr><td colspan="2">Serie</td><td>99.0</td></tr> <tr><td colspan="2">Total</td><td>195.2</td></tr> </table>	11:	8.9	→	12:	10.7x	↘	13:	9.0	↘	14:	10.2x	↓	15:	10.2x	↑	16:	10.0	→	17:	9.7	↗	18:	10.3x	↓	19:	10.6x	↗	20:	9.4	↙	Serie		99.0	Total		195.2	<p>60 Skott</p> 	<table border="1" style="width:100%; border-collapse: collapse;"> <tr><td>21:</td><td>10.1</td><td>↙</td></tr> <tr><td>22:</td><td>10.2x</td><td>↓</td></tr> <tr><td>23:</td><td>8.8</td><td>→</td></tr> <tr><td>24:</td><td>10.1</td><td>↙</td></tr> <tr><td>25:</td><td>9.8</td><td>↓</td></tr> <tr><td>26:</td><td>10.0</td><td>→</td></tr> <tr><td>27:</td><td>10.2x</td><td>↗</td></tr> <tr><td>28:</td><td>9.9</td><td>→</td></tr> <tr><td>29:</td><td>9.6</td><td>→</td></tr> <tr><td>30:</td><td>10.2x</td><td>↑</td></tr> <tr><td colspan="2">Serie</td><td>98.9</td></tr> <tr><td colspan="2">Total</td><td>294.1</td></tr> </table>	21:	10.1	↙	22:	10.2x	↓	23:	8.8	→	24:	10.1	↙	25:	9.8	↓	26:	10.0	→	27:	10.2x	↗	28:	9.9	→	29:	9.6	→	30:	10.2x	↑	Serie		98.9	Total		294.1
11:	8.9	→																																																																									
12:	10.7x	↘																																																																									
13:	9.0	↘																																																																									
14:	10.2x	↓																																																																									
15:	10.2x	↑																																																																									
16:	10.0	→																																																																									
17:	9.7	↗																																																																									
18:	10.3x	↓																																																																									
19:	10.6x	↗																																																																									
20:	9.4	↙																																																																									
Serie		99.0																																																																									
Total		195.2																																																																									
21:	10.1	↙																																																																									
22:	10.2x	↓																																																																									
23:	8.8	→																																																																									
24:	10.1	↙																																																																									
25:	9.8	↓																																																																									
26:	10.0	→																																																																									
27:	10.2x	↗																																																																									
28:	9.9	→																																																																									
29:	9.6	→																																																																									
30:	10.2x	↑																																																																									
Serie		98.9																																																																									
Total		294.1																																																																									
<p>60 Skott</p> 	<table border="1" style="width:100%; border-collapse: collapse;"> <tr><td>31:</td><td>10.4x</td><td>→</td></tr> <tr><td>32:</td><td>10.6x</td><td>↗</td></tr> <tr><td>33:</td><td>9.3</td><td>↗</td></tr> <tr><td>34:</td><td>9.1</td><td>↗</td></tr> <tr><td>35:</td><td>9.4</td><td>↓</td></tr> <tr><td>36:</td><td>9.4</td><td>↗</td></tr> <tr><td>37:</td><td>9.7</td><td>→</td></tr> <tr><td>38:</td><td>10.4x</td><td>↗</td></tr> <tr><td>39:</td><td>7.8</td><td>↗</td></tr> <tr><td>40:</td><td>10.5x</td><td>↗</td></tr> <tr><td colspan="2">Serie</td><td>96.6</td></tr> <tr><td colspan="2">Total</td><td>390.7</td></tr> </table>	31:	10.4x	→	32:	10.6x	↗	33:	9.3	↗	34:	9.1	↗	35:	9.4	↓	36:	9.4	↗	37:	9.7	→	38:	10.4x	↗	39:	7.8	↗	40:	10.5x	↗	Serie		96.6	Total		390.7																																						
31:	10.4x	→																																																																									
32:	10.6x	↗																																																																									
33:	9.3	↗																																																																									
34:	9.1	↗																																																																									
35:	9.4	↓																																																																									
36:	9.4	↗																																																																									
37:	9.7	→																																																																									
38:	10.4x	↗																																																																									
39:	7.8	↗																																																																									
40:	10.5x	↗																																																																									
Serie		96.6																																																																									
Total		390.7																																																																									

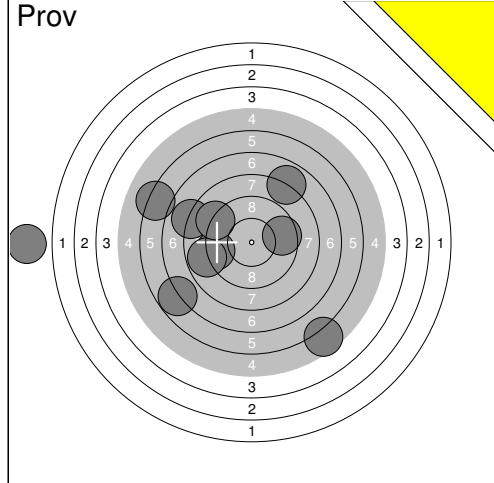

11:	8.2	↗
12:	10.1	↗
13:	9.6	↑
14:	5.9	→
15:	7.8	←
16:	7.7	←
17:	7.0	↘
18:	9.5	↘
19:	10.1	↘
20:	8.0	←
Serie	83.9	
Total	0.0	

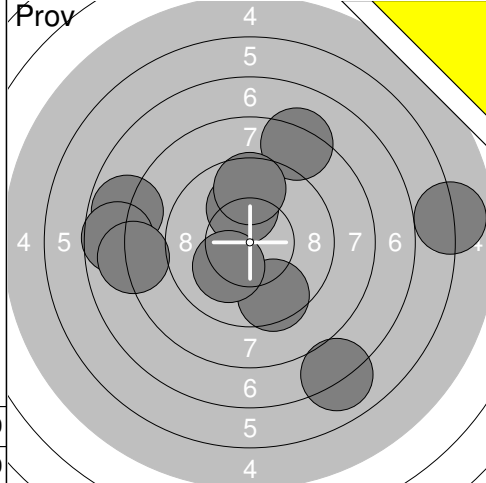

60 Skott

1:	9.0	↘
2:	10.0	→
3:	9.7	↑
4:	8.5	←
5:	9.3	↖
6:	6.4	→
7:	7.2	↘
8:	8.3	↖
9:	9.8	↑
10:	8.9	↘
Serie	87.1	
Total	87.1	

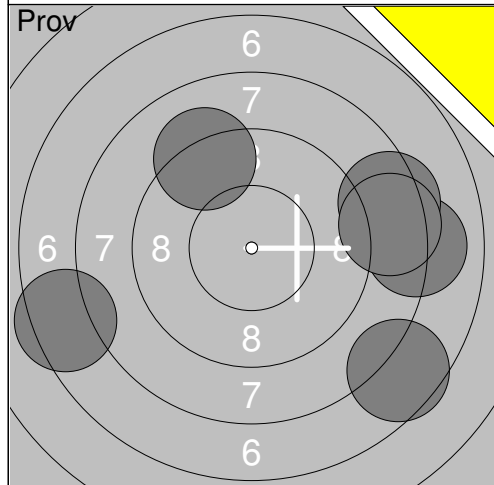

60 Skott

31:	9.5	↘
32:	9.4	↘
33:	8.6	↗
34:	8.8	↘
35:	6.9	→
36:	6.9	←
37:	10.0	←
38:	9.4	↗
39:	6.4	←
40:	7.9	→
Serie	83.8	
Total	339.8	

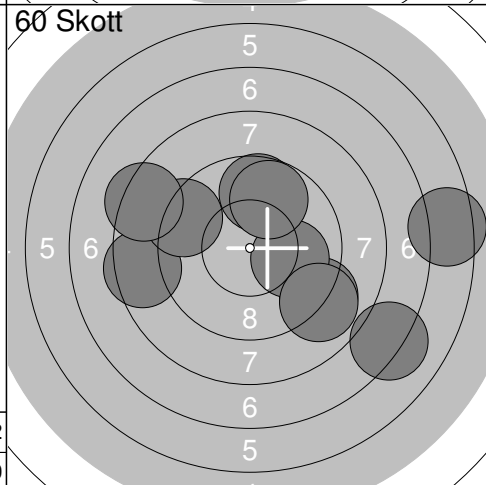

60 Skott

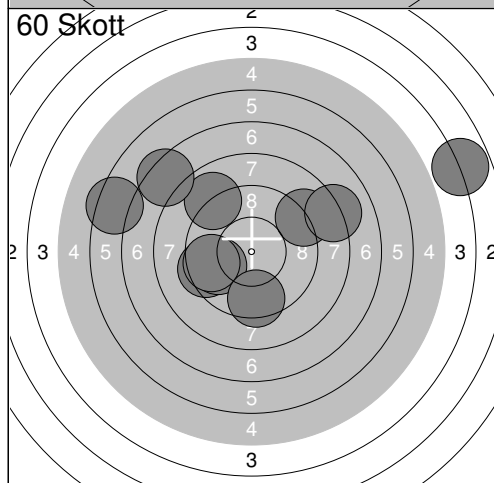
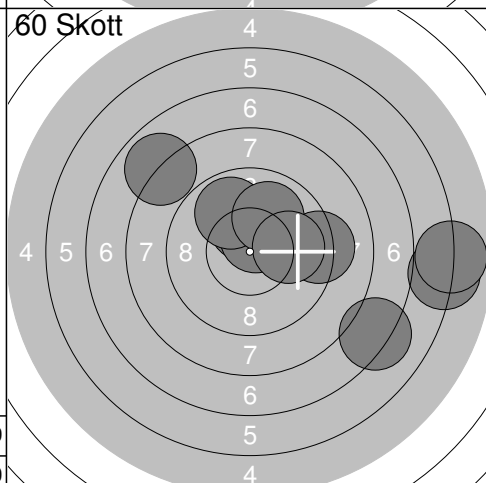
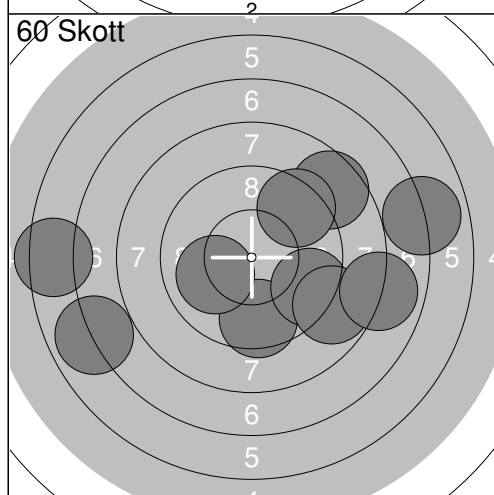
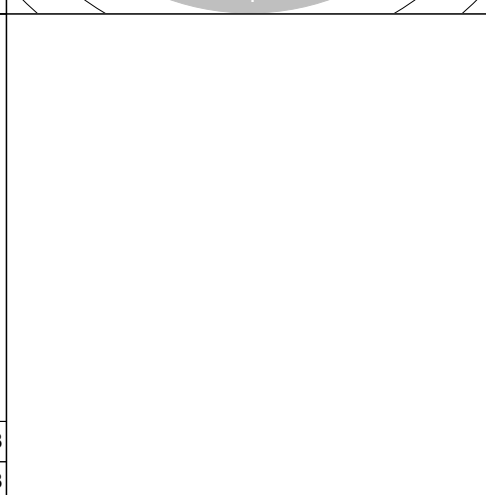

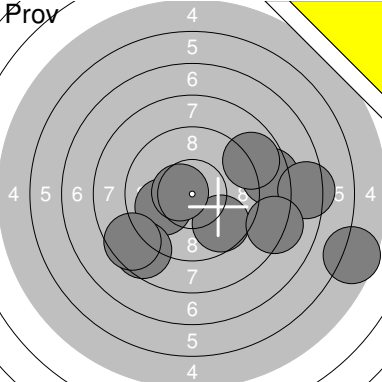
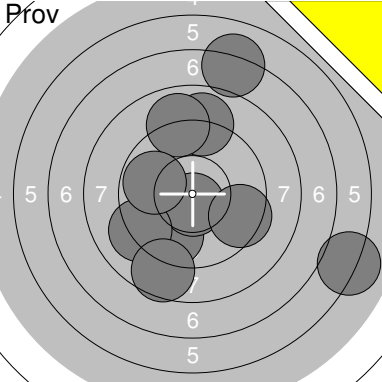
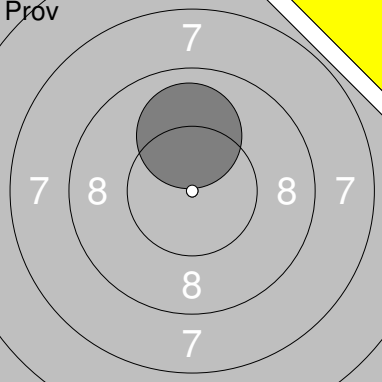
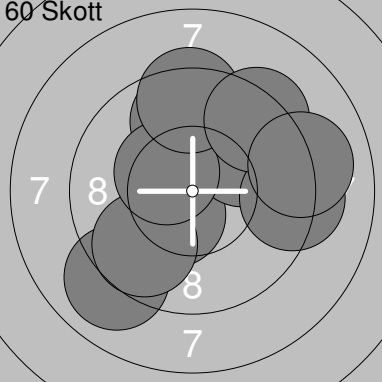
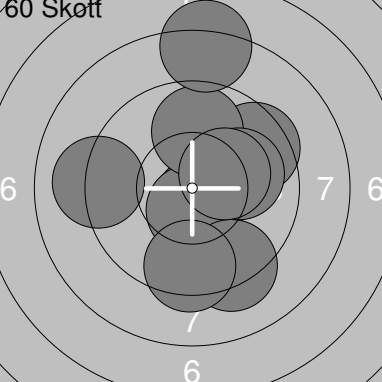
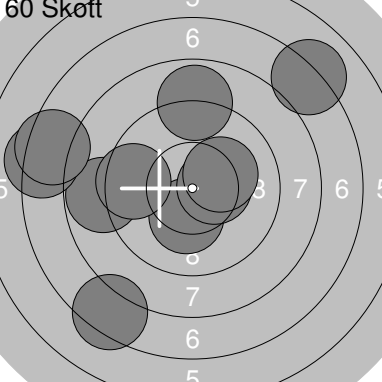
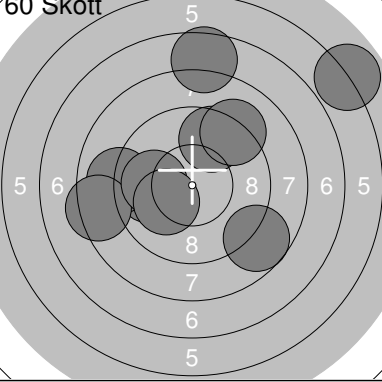
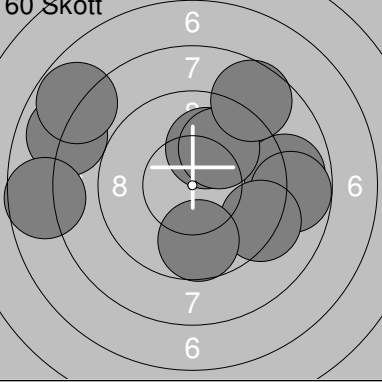
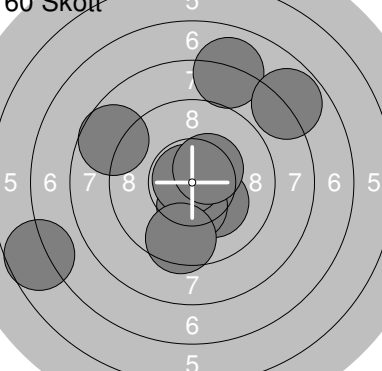

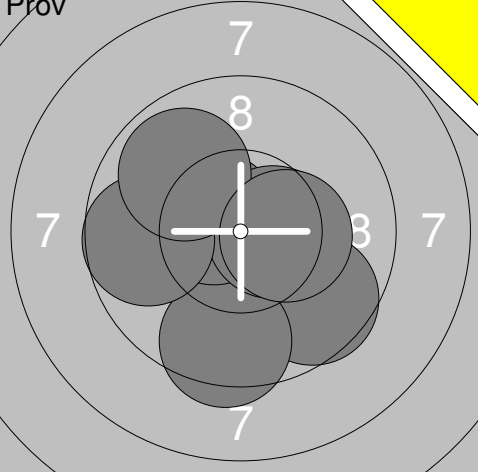
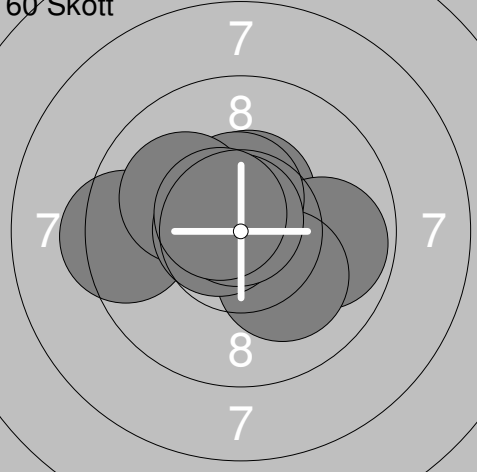
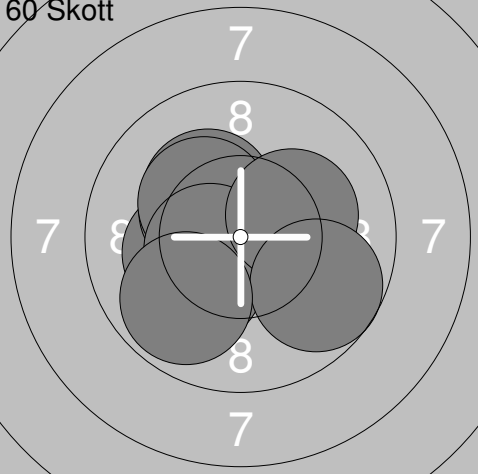
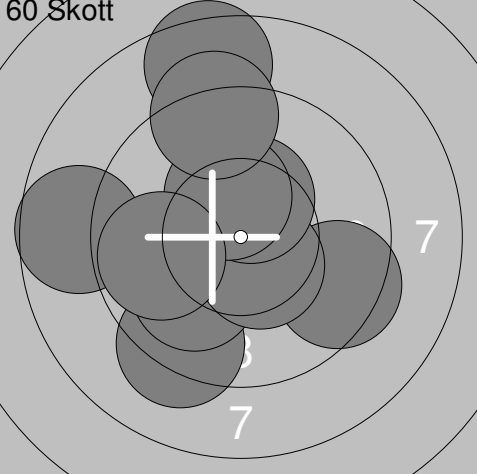
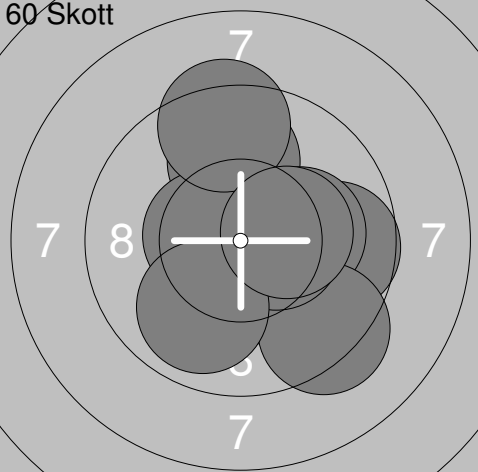
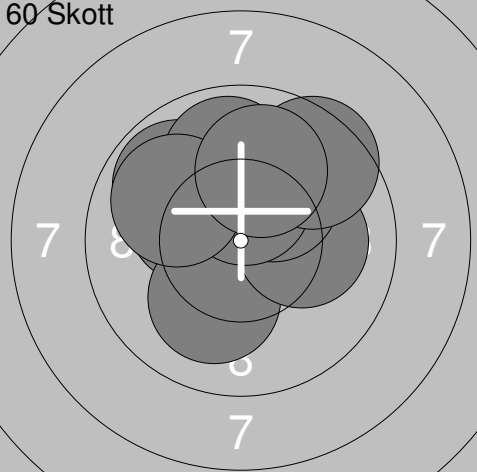
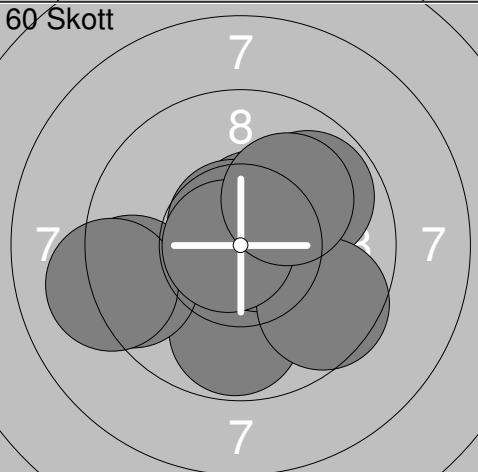

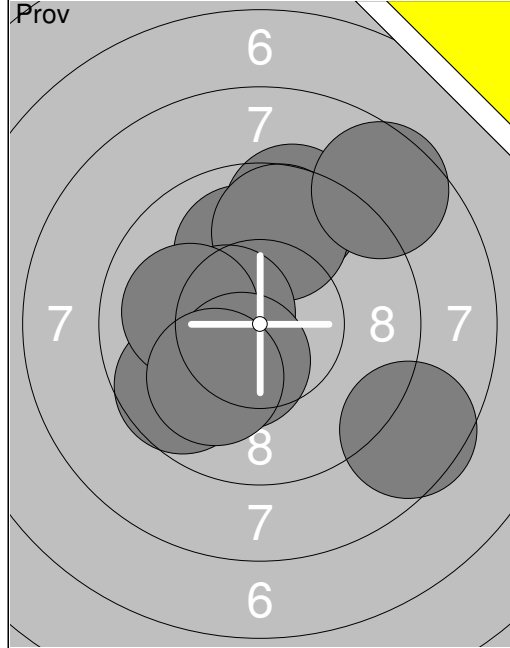
Skjutlag	Tavla	Isak Börjesson	
2	13		
S	Gideå		
25.02.2017	Vännästräffen 2017	Umeå skytteallians	
Prov 	1: 5.6 → 2: 9.7 ↓ 3: 10.0 ← 4: 8.4 → 5: 8.6 ↓ 6: 8.6 ← 7: 8.8 → 8: 10.6x ← 9: 7.4 → 10: 8.2 → Serie 85.9 Total 0.0	Prov 	11: 9.6 ↓ 12: 10.6x ↓ 13: 8.9 ↑ 14: 7.1 ↑ 15: 9.1 ← 16: 8.6 ↓ 17: 9.0 ↑ 18: 6.1 → 19: 9.5 → 20: 9.8 ← Serie 88.3 Total 0.0
Prov 	21: 10.0 ↑ Serie 10.0 Total 0.0	60 Skott 	1: 9.8 ↑ 2: 10.4x ↓ 3: 9.9 → 4: 9.0 ↓ 5: 9.7 ↓ 6: 9.3 → 7: 10.4x ↖ 8: 9.4 ↑ 9: 9.3 ↗ 10: 9.1 → Serie 96.3 Total 96.3
60 Skott 	11: 10.6x ↓ 12: 10.5x ↓ 13: 9.1 ← 14: 9.3 ↓ 15: 9.5 ↗ 16: 9.4 ↓ 17: 9.8 ↑ 18: 10.0 → 19: 8.2 ↑ 20: 10.3x ↗ Serie 96.7 Total 193.0	60 Skott 	21: 10.3x ↓ 22: 8.8 ← 23: 8.9 ↑ 24: 7.4 ↓ 25: 7.3 ← 26: 10.4x → 27: 7.5 ← 28: 10.2x ↗ 29: 9.5 ← 30: 7.1 ↗ Serie 87.4 Total 280.4
60 Skott 	31: 8.7 ↘ 32: 9.8 ← 33: 9.6 ↑ 34: 9.2 ↗ 35: 5.9 ↗ 36: 7.6 ↑ 37: 9.0 ← 38: 8.4 ← 39: 9.9 ← 40: 10.1 ↙ Serie 88.2 Total 368.6	60 Skott 	41: 8.9 → 42: 8.8 → 43: 9.2 → 44: 9.7 ↓ 45: 8.0 ← 46: 7.7 ← 47: 10.1 ↑ 48: 9.9 ↗ 49: 8.7 ↗ 50: 7.8 ↖ Serie 88.8 Total 457.4
60 Skott 	51: 6.7 ← 52: 10.4x ↓ 53: 8.0 ↑ 54: 10.2x ↓ 55: 8.7 ↗ 56: 10.4x ↓ 57: 10.8x ↗ 58: 7.8 ↗ 59: 9.5 ↓ 60: 10.4x ↗ Serie 92.9 Total 550.3		

<p>Pröv</p> 	<p>1: 10.2x ← 2: 9.6 ↓ 3: 9.5 ↓ 4: 10.5x ↗ 5: 10.5x → 6: 9.7 ← 7: 9.9 ↗ 8: 10.3x →</p> <p>Serie 80.2 Total 0.0</p>	<p>60 Skott</p> 	<p>1: 9.4 ← 2: 10.5x ↑ 3: 9.8 → 4: 10.5x ↑ 5: 10.1 ↓ 6: 10.7x ↖ 7: 10.1 ↗ 8: 10.7x ← 9: 10.8x ↑ 10: 10.6x ↖</p> <p>Serie 103.2 Total 103.2</p>
<p>60 Skott</p> 	<p>11: 10.1 ↘ 12: 10.4x ← 13: 10.2x ↗ 14: 10.2x ← 15: 10.4x ↗ 16: 10.3x ↗ 17: 10.5x ← 18: 10.2x → 19: 9.7 ↓ 20: 9.8 ↘</p> <p>Serie 101.8 Total 205.0</p>	<p>60 Skott</p> 	<p>21: 8.7 ← 22: 9.2 ↘ 23: 9.4 → 24: 10.0 ↘ 25: 8.5 ↑ 26: 10.5x ↓ 27: 10.4x ↑ 28: 10.4x ↑ 29: 9.2 ↑ 30: 9.8 ←</p> <p>Serie 96.1 Total 301.1</p>
<p>60 Skott</p> 	<p>31: 9.9 ↑ 32: 9.7 → 33: 10.1 → 34: 10.4x ↓ 35: 9.3 ↓ 36: 10.5x → 37: 10.5x ← 38: 9.4 ↑ 39: 9.9 ↓ 40: 10.3x →</p> <p>Serie 100.0 Total 401.1</p>	<p>60 Skott</p> 	<p>41: 10.2x ↖ 42: 10.1 ↓ 43: 10.1 → 44: 10.2x ↗ 45: 9.8 ↖ 46: 9.9 ↑ 47: 10.4x ↑ 48: 9.5 ↗ 49: 9.9 ↖ 50: 10.0 ↑</p> <p>Serie 100.1 Total 501.2</p>
<p>60 Skott</p> 	<p>51: 10.5x ↗ 52: 9.8 ↓ 53: 9.8 ↗ 54: 10.7x → 55: 9.6 ↓ 56: 9.4 ← 57: 10.7x ↑ 58: 9.1 ← 59: 10.8x ← 60: 10.1 ↗</p> <p>Serie 100.5 Total 601.7</p>		

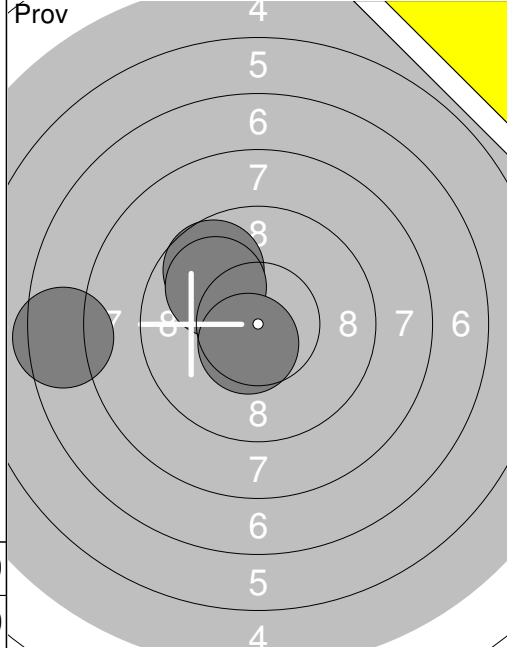

1:	10.0	↑
2:	9.4	↑
3:	9.7	↑
4:	10.5	↔
5:	9.7	↙
6:	10.0	↔
7:	8.6	↘
8:	8.6	↗
9:	10.4	↘
10:	10.0	↘
Serie	96.9	
Total	0.0	



11:	7.5	↔
12:	9.7	↖
13:	9.9	↖
14:	10.6	↘
Serie	37.7	
Total	0.0	

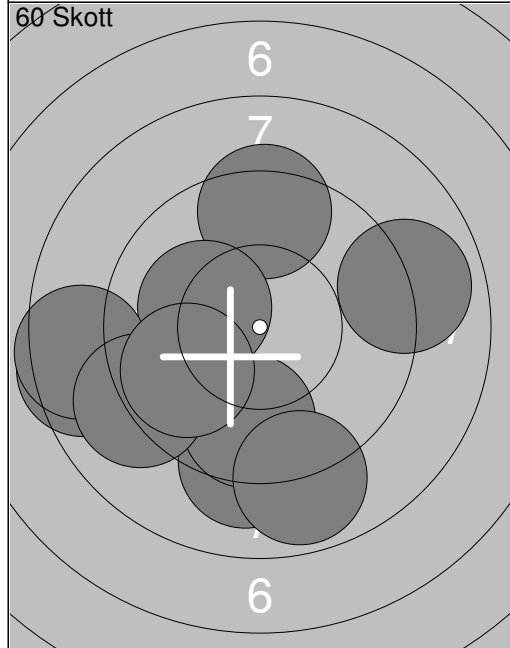

1:	8.5	↔
2:	9.1	↓
3:	9.4	↑
4:	9.7	↓
5:	10.2	↔
6:	8.5	↔
7:	8.9	→
8:	9.1	↔
9:	8.9	↓
10:	9.8	↔
Serie	92.1	
Total	92.1	

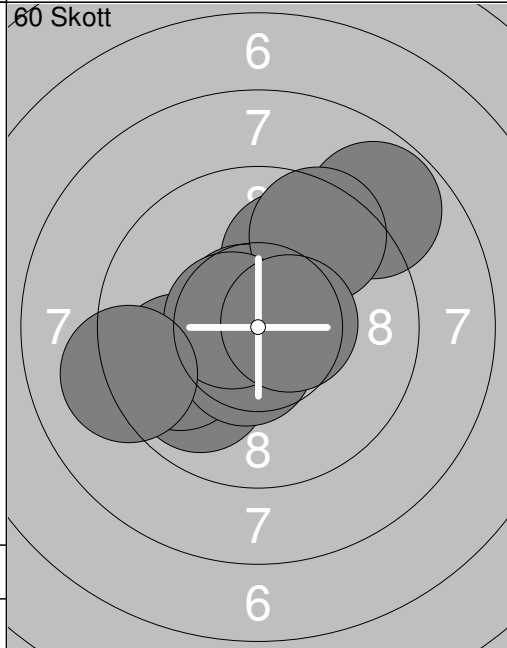

11:	10.0	↗
12:	9.9	↙
13:	8.8	↗
14:	10.7	↔
15:	9.8	↔
16:	10.5	↘
17:	9.5	↗
18:	10.6	↔
19:	9.2	↔
20:	10.5	↘
Serie	99.5	
Total	191.6	

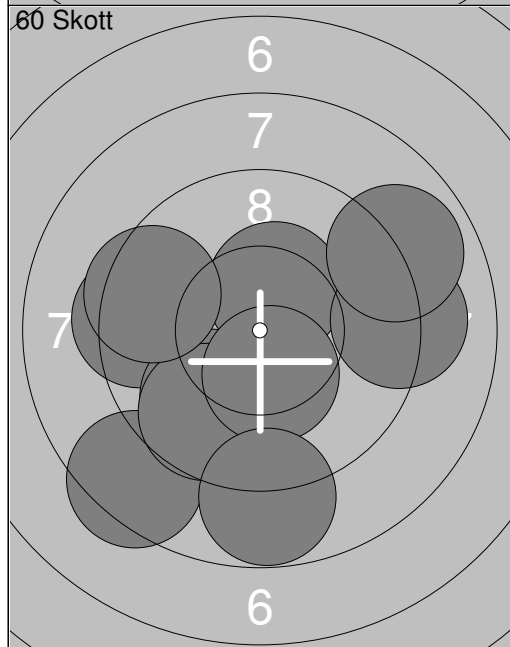

21:	10.4	↗
22:	9.1	→
23:	9.4	↔
24:	9.8	↙
25:	8.9	↗
26:	8.4	↙
27:	9.7	↙
28:	9.5	↔
29:	10.4	↘
30:	8.8	↓
Serie	94.4	
Total	286.0	

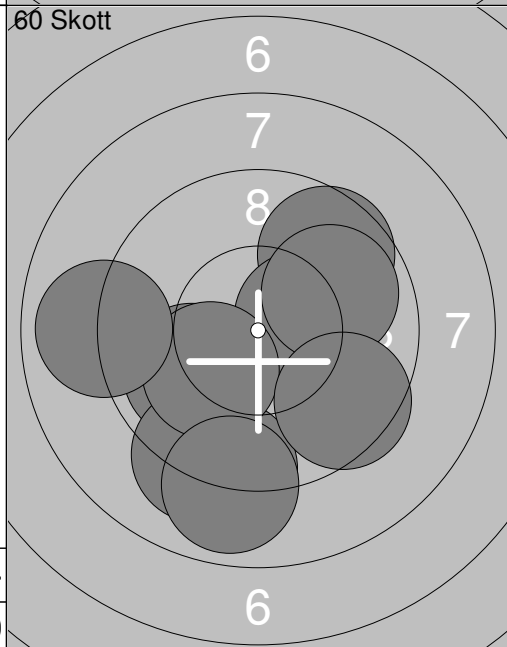

31:	9.6	↗
32:	9.1	↓
33:	9.9	↔
34:	9.2	↓
35:	10.3	↘
36:	10.1	↙
37:	8.9	↓
38:	8.9	↔
39:	9.9	↗
40:	9.5	↘
Serie	95.4	
Total	381.4	

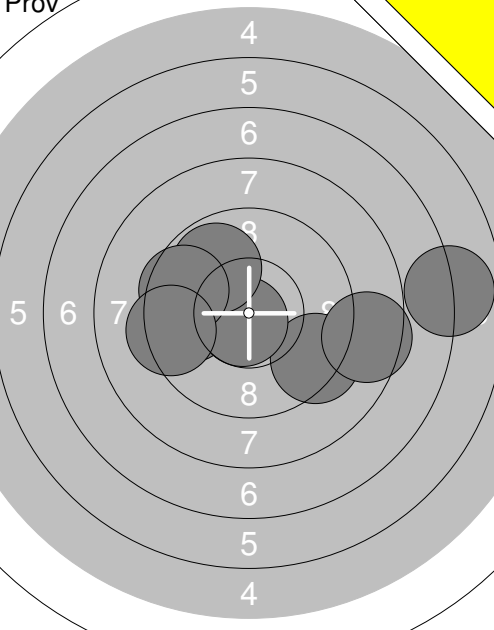
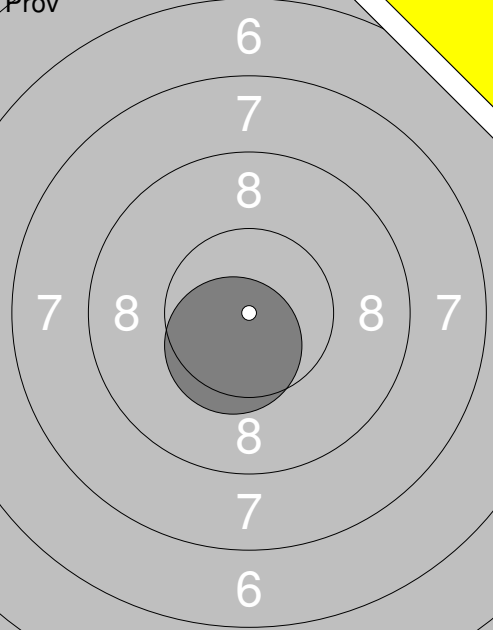
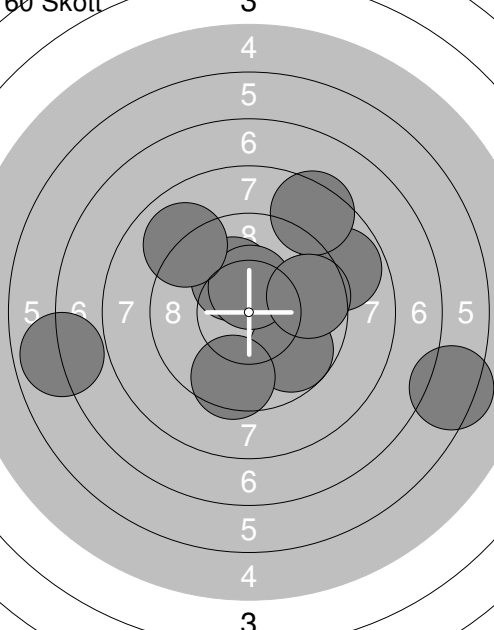
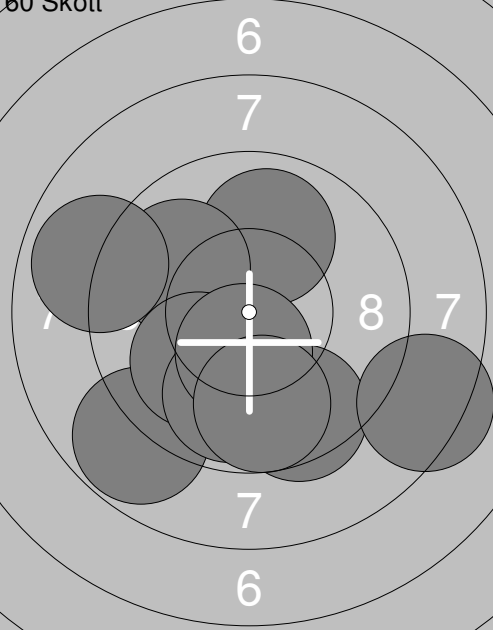
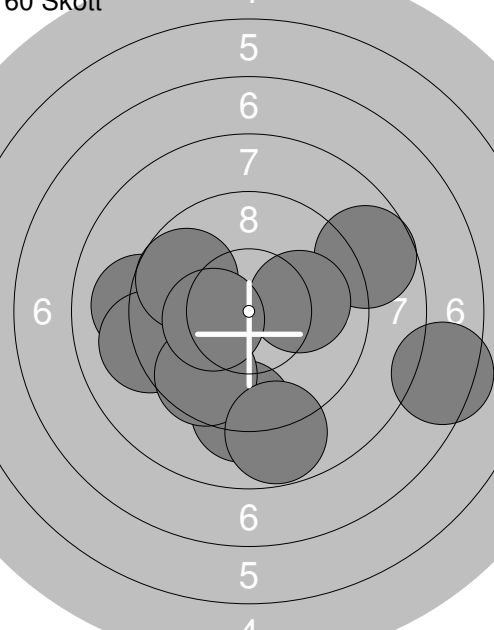
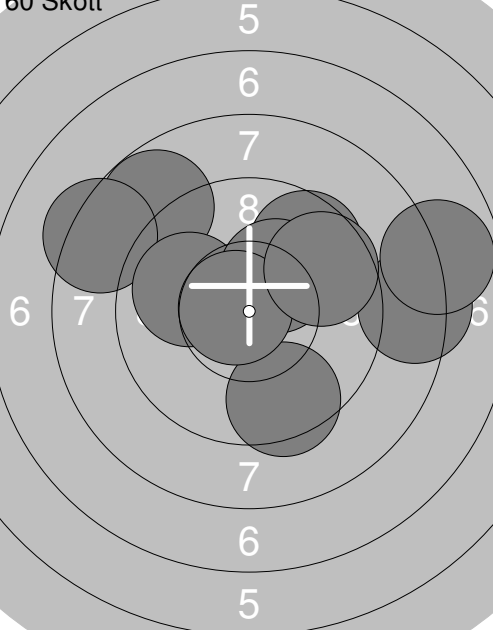
<p>Prov</p> 	<p>1: 9.3 ↘ 2: 10.2x↔ 3: 8.6 → 4: 9.8 ← 5: 6.9 → 6: 10.7x↘ 7: 9.8 ↗ 8: 9.6 ← 10: 9.4 ←</p> <p>Serie 84.3 Total 0.0</p>	<p>Prov</p> 	<p>11: 10.5x↘</p> <p>Serie 10.5 Total 0.0</p>
<p>60 Skott</p> 	<p>1: 8.8 → 2: 10.2x↘ 3: 9.7 ↘ 4: 10.4x↗ 5: 9.5 ↓ 6: 6.4 → 7: 6.9 ← 8: 9.0 ↗ 9: 8.5 ↗ 10: 9.6 →</p> <p>Serie 89.0 Total 89.0</p>	<p>60 Skott</p> 	<p>11: 9.9 ↗ 12: 8.8 ↘ 13: 9.9 ↖ 14: 8.9 ← 15: 10.0 ↘ 16: 9.5 ↓ 17: 9.9 ↓ 18: 8.4 → 19: 10.4x↘ 20: 9.7 ↓</p> <p>Serie 95.4 Total 184.4</p>
<p>60 Skott</p> 	<p>21: 9.1 ← 22: 9.1 ← 23: 8.7 → 24: 9.2 ↓ 25: 9.6 ↘ 26: 7.4 → 27: 9.7 ↖ 28: 8.8 ↓ 29: 10.0 → 30: 10.3x↖</p> <p>Serie 91.9 Total 276.3</p>	<p>60 Skott</p> 	<p>31: 9.5 ↓ 32: 8.8 ↖ 33: 8.3 → 34: 9.6 ↗ 35: 7.9 → 36: 8.3 ↖ 37: 10.0 ← 38: 10.3x↗ 39: 10.7x↖ 40: 9.6 ↗</p> <p>Serie 93.0 Total 369.3</p>

<p>Prov</p>	<p>1: 9.6 ←</p> <p>2: 9.7 ←</p> <p>3: 10.4x↘</p> <p>4: 10.2x↘</p> <p>5: 10.0 ↓</p> <p>6: 9.5 ↘</p> <p>7: 9.8 →</p> <p>8: 10.3x↘</p> <p>9: 9.7 ↑</p> <p>10: 9.7 ←</p> <hr/> <p>Serie 98.9</p> <hr/> <p>Total 0.0</p>	<p>Prov</p>	<p>11: 9.8 ↗</p> <p>12: 10.3x↘</p> <p>13: 10.6x↗</p> <hr/> <p>Serie 30.7</p> <hr/> <p>Total 0.0</p>
<p>60 Skott</p>	<p>1: 8.2 ↗</p> <p>2: 9.3 ↗</p> <p>3: 8.8 ↑</p> <p>4: 9.4 ↗</p> <p>5: 10.0 ↗</p> <p>6: 9.2 ←</p> <p>7: 10.0 →</p> <p>8: 10.2x↑</p> <p>9: 9.4 →</p> <p>10: 9.8 →</p> <hr/> <p>Serie 94.3</p> <hr/> <p>Total 94.3</p>	<p>60 Skott</p>	<p>11: 10.2x↓</p> <p>12: 10.1 ↓</p> <p>13: 9.4 ↖</p> <p>14: 10.7x↘</p> <p>15: 9.9 ↓</p> <p>16: 10.0 →</p> <p>17: 10.1 ↗</p> <p>18: 9.7 ←</p> <p>19: 9.6 ↑</p> <p>20: 10.2x↓</p> <hr/> <p>Serie 99.9</p> <hr/> <p>Total 194.2</p>
<p>60 Skott</p>	<p>21: 10.1 ↗</p> <p>22: 10.0 ↑</p> <p>23: 9.6 →</p> <p>24: 9.9 ↑</p> <p>25: 9.9 ↘</p> <p>26: 9.8 ↖</p> <p>27: 9.6 ↗</p> <p>28: 10.3x↑</p> <p>29: 10.0 →</p> <p>30: 9.0 ←</p> <hr/> <p>Serie 98.2</p> <hr/> <p>Total 292.4</p>	<p>60 Skott</p>	<p>31: 10.3x↓</p> <p>32: 10.8x↑</p> <p>33: 9.7 ↗</p> <p>34: 9.6 →</p> <p>35: 10.0 ↑</p> <p>36: 10.1 ↓</p> <p>37: 10.3x↗</p> <p>38: 10.6x↓</p> <p>39: 10.0 ↑</p> <p>40: 10.4x↘</p> <hr/> <p>Serie 101.8</p> <hr/> <p>Total 394.2</p>

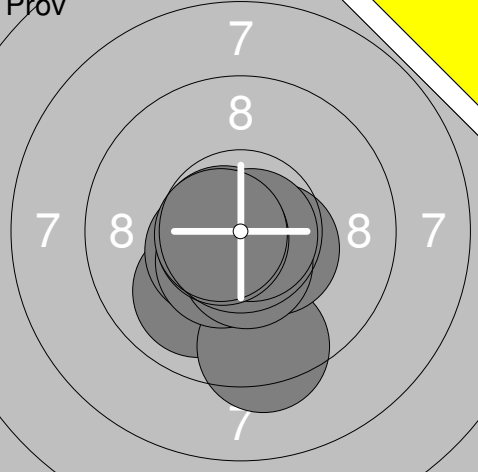
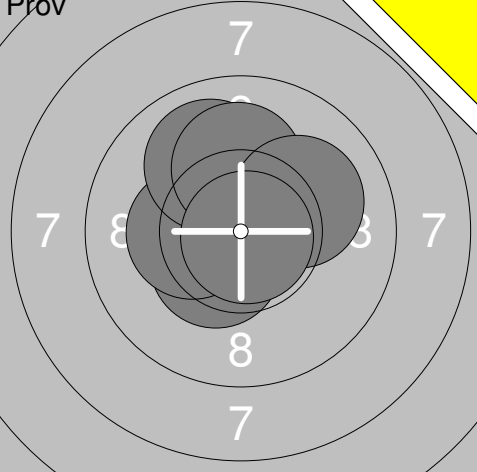
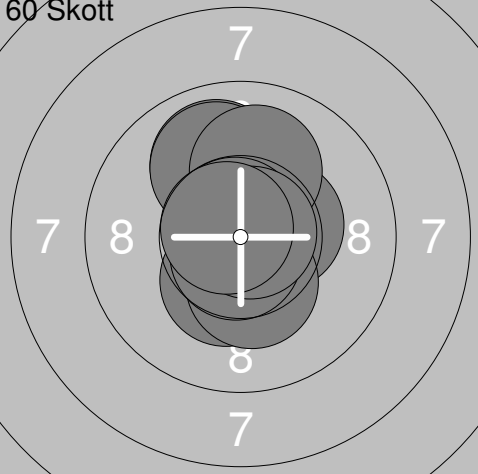
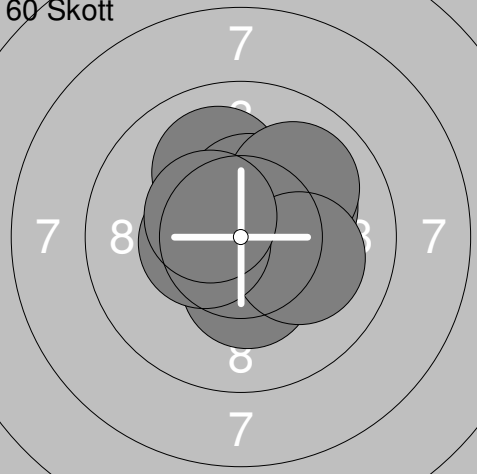
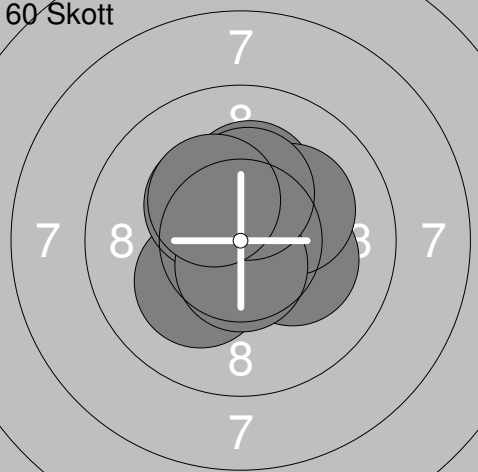
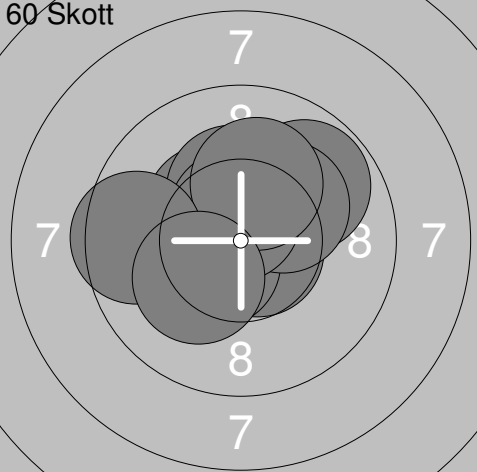
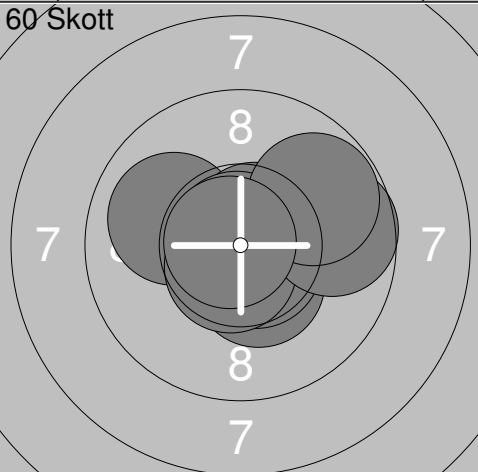
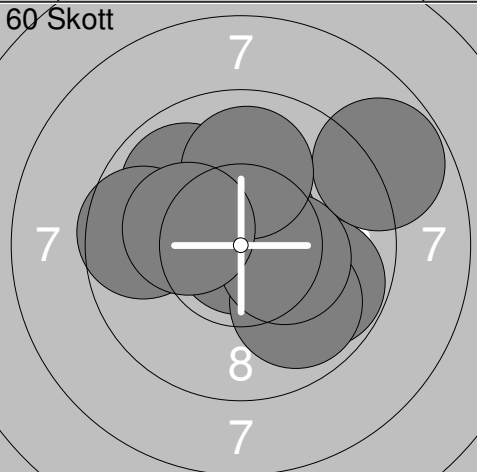
<p>Pröv</p> 	<table border="1" style="width:100%; border-collapse: collapse;"> <tr><td>1:</td><td>10.0</td><td>↙</td></tr> <tr><td>2:</td><td>9.4</td><td>↘</td></tr> <tr><td>3:</td><td>10.5x</td><td>↙</td></tr> <tr><td>4:</td><td>10.5x</td><td>↘</td></tr> <tr><td>5:</td><td>10.7x</td><td>←</td></tr> <tr><td>6:</td><td>10.5x</td><td>↘</td></tr> <tr><td>7:</td><td>10.5x</td><td>↘</td></tr> <tr><td>8:</td><td>10.8x</td><td>→</td></tr> <tr><td>9:</td><td>10.7x</td><td>←</td></tr> <tr><td>10:</td><td>10.7x</td><td>←</td></tr> <tr><td colspan="2">Serie</td><td>104.3</td></tr> <tr><td colspan="2">Total</td><td>0.0</td></tr> </table>	1:	10.0	↙	2:	9.4	↘	3:	10.5x	↙	4:	10.5x	↘	5:	10.7x	←	6:	10.5x	↘	7:	10.5x	↘	8:	10.8x	→	9:	10.7x	←	10:	10.7x	←	Serie		104.3	Total		0.0	<p>Pröv</p>  <table border="1" style="width:100%; border-collapse: collapse;"> <tr><td>11:</td><td>10.4x</td><td>↙</td></tr> <tr><td>12:</td><td>10.3x</td><td>←</td></tr> <tr><td>13:</td><td>10.0</td><td>↗</td></tr> <tr><td>14:</td><td>10.1</td><td>↗</td></tr> <tr><td>15:</td><td>10.1</td><td>→</td></tr> <tr><td>16:</td><td>10.8x</td><td>↘</td></tr> <tr><td colspan="2">Serie</td><td>61.7</td></tr> <tr><td colspan="2">Total</td><td>0.0</td></tr> </table>	11:	10.4x	↙	12:	10.3x	←	13:	10.0	↗	14:	10.1	↗	15:	10.1	→	16:	10.8x	↘	Serie		61.7	Total		0.0												
1:	10.0	↙																																																																								
2:	9.4	↘																																																																								
3:	10.5x	↙																																																																								
4:	10.5x	↘																																																																								
5:	10.7x	←																																																																								
6:	10.5x	↘																																																																								
7:	10.5x	↘																																																																								
8:	10.8x	→																																																																								
9:	10.7x	←																																																																								
10:	10.7x	←																																																																								
Serie		104.3																																																																								
Total		0.0																																																																								
11:	10.4x	↙																																																																								
12:	10.3x	←																																																																								
13:	10.0	↗																																																																								
14:	10.1	↗																																																																								
15:	10.1	→																																																																								
16:	10.8x	↘																																																																								
Serie		61.7																																																																								
Total		0.0																																																																								
<p>60 Skott</p> 	<table border="1" style="width:100%; border-collapse: collapse;"> <tr><td>1:</td><td>9.9</td><td>↗</td></tr> <tr><td>2:</td><td>10.0</td><td>↗</td></tr> <tr><td>3:</td><td>10.4x</td><td>→</td></tr> <tr><td>4:</td><td>10.3x</td><td>↘</td></tr> <tr><td>5:</td><td>10.0</td><td>↗</td></tr> <tr><td>6:</td><td>10.8x</td><td>↗</td></tr> <tr><td>7:</td><td>10.3x</td><td>↘</td></tr> <tr><td>8:</td><td>10.7x</td><td>↘</td></tr> <tr><td>9:</td><td>10.8x</td><td>→</td></tr> <tr><td>10:</td><td>10.7x</td><td>↗</td></tr> <tr><td colspan="2">Serie</td><td>103.9</td></tr> <tr><td colspan="2">Total</td><td>103.9</td></tr> </table>	1:	9.9	↗	2:	10.0	↗	3:	10.4x	→	4:	10.3x	↘	5:	10.0	↗	6:	10.8x	↗	7:	10.3x	↘	8:	10.7x	↘	9:	10.8x	→	10:	10.7x	↗	Serie		103.9	Total		103.9	<p>60 Skott</p>  <table border="1" style="width:100%; border-collapse: collapse;"> <tr><td>11:</td><td>10.0</td><td>↗</td></tr> <tr><td>12:</td><td>10.4x</td><td>↗</td></tr> <tr><td>13:</td><td>10.5x</td><td>↗</td></tr> <tr><td>14:</td><td>10.2x</td><td>→</td></tr> <tr><td>15:</td><td>10.4x</td><td>↗</td></tr> <tr><td>16:</td><td>10.0</td><td>↗</td></tr> <tr><td>17:</td><td>10.3x</td><td>↘</td></tr> <tr><td>18:</td><td>10.1</td><td>→</td></tr> <tr><td>19:</td><td>10.5x</td><td>←</td></tr> <tr><td>20:</td><td>10.5x</td><td>↗</td></tr> <tr><td colspan="2">Serie</td><td>102.9</td></tr> <tr><td colspan="2">Total</td><td>206.8</td></tr> </table>	11:	10.0	↗	12:	10.4x	↗	13:	10.5x	↗	14:	10.2x	→	15:	10.4x	↗	16:	10.0	↗	17:	10.3x	↘	18:	10.1	→	19:	10.5x	←	20:	10.5x	↗	Serie		102.9	Total		206.8
1:	9.9	↗																																																																								
2:	10.0	↗																																																																								
3:	10.4x	→																																																																								
4:	10.3x	↘																																																																								
5:	10.0	↗																																																																								
6:	10.8x	↗																																																																								
7:	10.3x	↘																																																																								
8:	10.7x	↘																																																																								
9:	10.8x	→																																																																								
10:	10.7x	↗																																																																								
Serie		103.9																																																																								
Total		103.9																																																																								
11:	10.0	↗																																																																								
12:	10.4x	↗																																																																								
13:	10.5x	↗																																																																								
14:	10.2x	→																																																																								
15:	10.4x	↗																																																																								
16:	10.0	↗																																																																								
17:	10.3x	↘																																																																								
18:	10.1	→																																																																								
19:	10.5x	←																																																																								
20:	10.5x	↗																																																																								
Serie		102.9																																																																								
Total		206.8																																																																								
<p>60 Skott</p> 	<table border="1" style="width:100%; border-collapse: collapse;"> <tr><td>21:</td><td>10.9x</td><td>←</td></tr> <tr><td>22:</td><td>10.2x</td><td>↗</td></tr> <tr><td>23:</td><td>10.6x</td><td>↗</td></tr> <tr><td>24:</td><td>10.2x</td><td>↙</td></tr> <tr><td>25:</td><td>10.3x</td><td>↗</td></tr> <tr><td>26:</td><td>10.2x</td><td>→</td></tr> <tr><td>27:</td><td>10.2x</td><td>↗</td></tr> <tr><td>28:</td><td>10.6x</td><td>↘</td></tr> <tr><td>29:</td><td>10.3x</td><td>↗</td></tr> <tr><td>30:</td><td>10.3x</td><td>↗</td></tr> <tr><td colspan="2">Serie</td><td>103.8</td></tr> <tr><td colspan="2">Total</td><td>310.6</td></tr> </table>	21:	10.9x	←	22:	10.2x	↗	23:	10.6x	↗	24:	10.2x	↙	25:	10.3x	↗	26:	10.2x	→	27:	10.2x	↗	28:	10.6x	↘	29:	10.3x	↗	30:	10.3x	↗	Serie		103.8	Total		310.6	<p>60 Skott</p>  <table border="1" style="width:100%; border-collapse: collapse;"> <tr><td>31:</td><td>10.4x</td><td>↗</td></tr> <tr><td>32:</td><td>10.7x</td><td>↘</td></tr> <tr><td>33:</td><td>10.3x</td><td>↗</td></tr> <tr><td>34:</td><td>10.5x</td><td>↙</td></tr> <tr><td>35:</td><td>9.8</td><td>↗</td></tr> <tr><td>36:</td><td>10.2x</td><td>↗</td></tr> <tr><td>37:</td><td>10.6x</td><td>↗</td></tr> <tr><td>38:</td><td>10.2x</td><td>↗</td></tr> <tr><td>39:</td><td>9.5</td><td>←</td></tr> <tr><td>40:</td><td>10.2x</td><td>↙</td></tr> <tr><td colspan="2">Serie</td><td>102.4</td></tr> <tr><td colspan="2">Total</td><td>413.0</td></tr> </table>	31:	10.4x	↗	32:	10.7x	↘	33:	10.3x	↗	34:	10.5x	↙	35:	9.8	↗	36:	10.2x	↗	37:	10.6x	↗	38:	10.2x	↗	39:	9.5	←	40:	10.2x	↙	Serie		102.4	Total		413.0
21:	10.9x	←																																																																								
22:	10.2x	↗																																																																								
23:	10.6x	↗																																																																								
24:	10.2x	↙																																																																								
25:	10.3x	↗																																																																								
26:	10.2x	→																																																																								
27:	10.2x	↗																																																																								
28:	10.6x	↘																																																																								
29:	10.3x	↗																																																																								
30:	10.3x	↗																																																																								
Serie		103.8																																																																								
Total		310.6																																																																								
31:	10.4x	↗																																																																								
32:	10.7x	↘																																																																								
33:	10.3x	↗																																																																								
34:	10.5x	↙																																																																								
35:	9.8	↗																																																																								
36:	10.2x	↗																																																																								
37:	10.6x	↗																																																																								
38:	10.2x	↗																																																																								
39:	9.5	←																																																																								
40:	10.2x	↙																																																																								
Serie		102.4																																																																								
Total		413.0																																																																								
<p>60 Skott</p> 	<table border="1" style="width:100%; border-collapse: collapse;"> <tr><td>41:</td><td>10.0</td><td>↙</td></tr> <tr><td>42:</td><td>10.7x</td><td>↗</td></tr> <tr><td>43:</td><td>10.4x</td><td>↘</td></tr> <tr><td>44:</td><td>10.7x</td><td>→</td></tr> <tr><td>45:</td><td>10.8x</td><td>↗</td></tr> <tr><td>46:</td><td>10.6x</td><td>↘</td></tr> <tr><td>47:</td><td>10.6x</td><td>↘</td></tr> <tr><td>48:</td><td>9.7</td><td>→</td></tr> <tr><td>49:</td><td>9.8</td><td>↗</td></tr> <tr><td>50:</td><td>10.8x</td><td>←</td></tr> <tr><td colspan="2">Serie</td><td>104.1</td></tr> <tr><td colspan="2">Total</td><td>517.1</td></tr> </table>	41:	10.0	↙	42:	10.7x	↗	43:	10.4x	↘	44:	10.7x	→	45:	10.8x	↗	46:	10.6x	↘	47:	10.6x	↘	48:	9.7	→	49:	9.8	↗	50:	10.8x	←	Serie		104.1	Total		517.1	<p>60 Skott</p>  <table border="1" style="width:100%; border-collapse: collapse;"> <tr><td>51:</td><td>9.8</td><td>→</td></tr> <tr><td>52:</td><td>10.9x</td><td>↘</td></tr> <tr><td>53:</td><td>9.9</td><td>↘</td></tr> <tr><td>54:</td><td>10.6x</td><td>↗</td></tr> <tr><td>55:</td><td>10.3x</td><td>→</td></tr> <tr><td>56:</td><td>9.9</td><td>↗</td></tr> <tr><td>57:</td><td>8.8</td><td>↗</td></tr> <tr><td>58:</td><td>9.6</td><td>←</td></tr> <tr><td>59:</td><td>10.0</td><td>↗</td></tr> <tr><td>60:</td><td>10.2x</td><td>←</td></tr> <tr><td colspan="2">Serie</td><td>100.0</td></tr> <tr><td colspan="2">Total</td><td>617.1</td></tr> </table>	51:	9.8	→	52:	10.9x	↘	53:	9.9	↘	54:	10.6x	↗	55:	10.3x	→	56:	9.9	↗	57:	8.8	↗	58:	9.6	←	59:	10.0	↗	60:	10.2x	←	Serie		100.0	Total		617.1
41:	10.0	↙																																																																								
42:	10.7x	↗																																																																								
43:	10.4x	↘																																																																								
44:	10.7x	→																																																																								
45:	10.8x	↗																																																																								
46:	10.6x	↘																																																																								
47:	10.6x	↘																																																																								
48:	9.7	→																																																																								
49:	9.8	↗																																																																								
50:	10.8x	←																																																																								
Serie		104.1																																																																								
Total		517.1																																																																								
51:	9.8	→																																																																								
52:	10.9x	↘																																																																								
53:	9.9	↘																																																																								
54:	10.6x	↗																																																																								
55:	10.3x	→																																																																								
56:	9.9	↗																																																																								
57:	8.8	↗																																																																								
58:	9.6	←																																																																								
59:	10.0	↗																																																																								
60:	10.2x	←																																																																								
Serie		100.0																																																																								
Total		617.1																																																																								

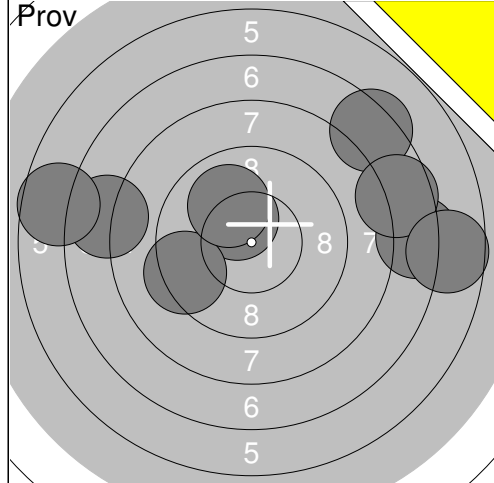

1:	7.4	↗
2:	7.7	←
3:	6.7	←
4:	7.3	→
5:	7.6	→
6:	10.3x	↗
7:	9.3	←
8:	6.7	→
10:	10.0	↗
Serie		73.0
Total		0.0

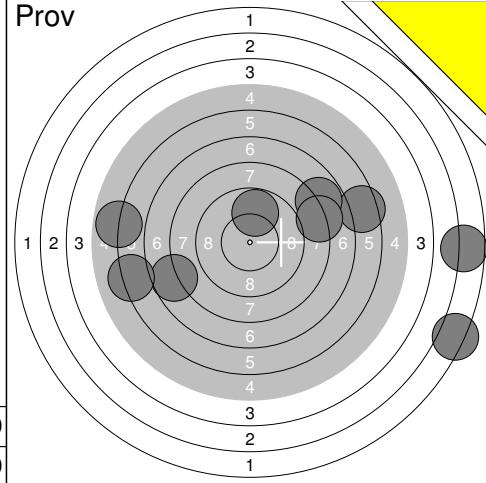

12:	7.7	↖
13:	6.4	→
14:	2.7	→
15:	6.2	←
16:	7.8	↗
17:	9.8	↑
18:	8.1	→
19:	5.8	←
20:	2.2	→
Serie		56.7
Total		0.0

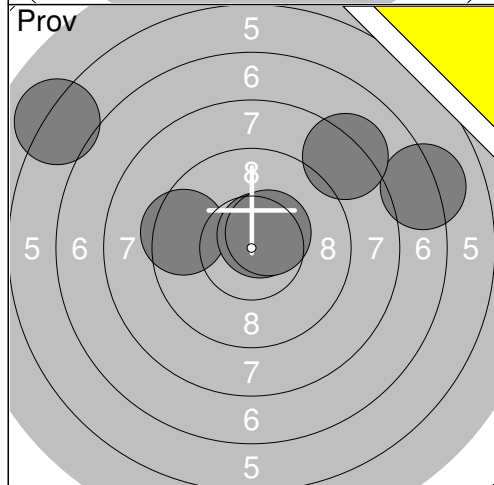

21:	7.1	→
22:	9.5	←
23:	10.6x	↗
24:	10.5x	↗
25:	8.2	↗
26:	6.1	↗
Serie		52.0
Total		0.0

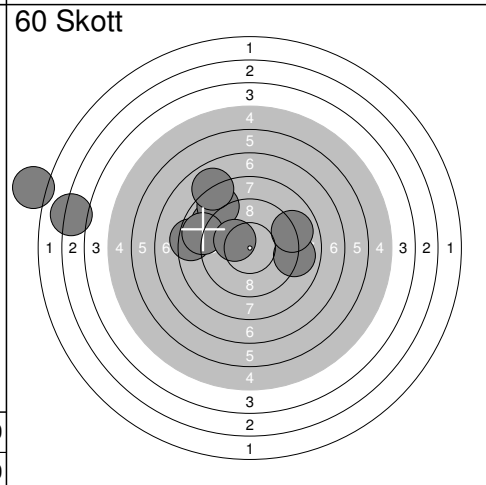

1:	3.1	←
2:	9.0	↗
3:	8.7	↗
4:	9.0	→
5:	8.4	←
6:	7.9	↗
7:	1.3	←
8:	8.8	←
9:	10.2x	↖
10:	9.0	→
Serie		75.4
Total		75.4

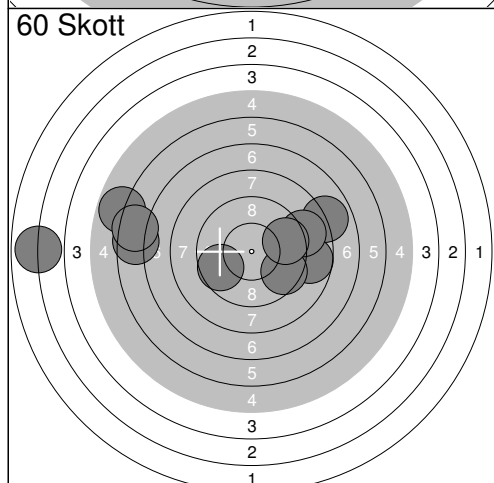

11:	8.7	→
12:	5.8	←
13:	2.9	←
14:	7.9	→
15:	6.5	←
16:	6.5	←
17:	9.5	↘
18:	8.9	→
19:	9.6	→
20:	9.6	←
Serie		75.9
Total		151.3

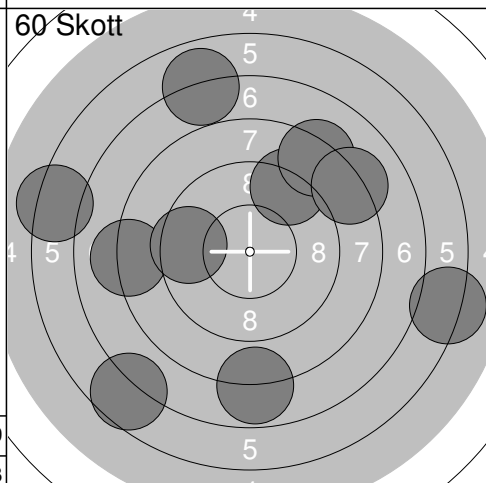

21:	7.8	↓
22:	9.2	↗
23:	6.2	→
24:	6.9	↗
25:	8.3	↗
26:	6.3	←
27:	8.1	←
28:	8.2	↗
29:	6.6	↘
30:	9.5	←
Serie		77.1
Total		228.4

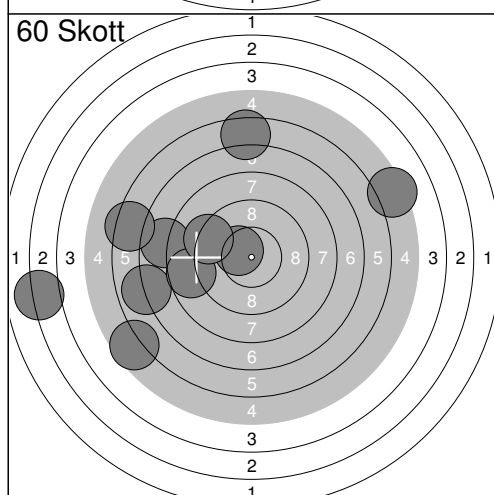

31:	6.9	←
32:	3.1	←
33:	7.8	←
34:	5.6	↖
35:	6.4	←
36:	5.3	→
37:	6.5	↑
38:	10.4x	↖
39:	8.7	←
40:	9.2	↖
Serie		69.9
Total		298.3

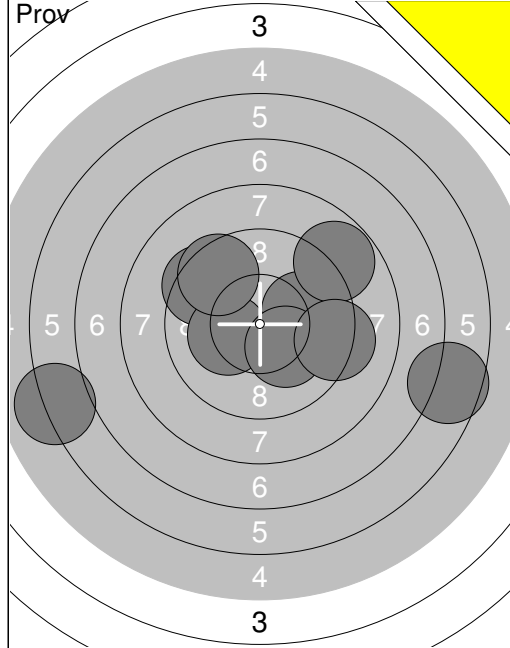

1: 6.6	➔
2: 10.0	➔
3: 9.4	↖
4: 6.1	↖
5: 8.8	↗
7: 10.2	✕
8: 10.2	✕
9: 9.3	➔
10: 9.5	↖
Serie	80.1
Total	0.0

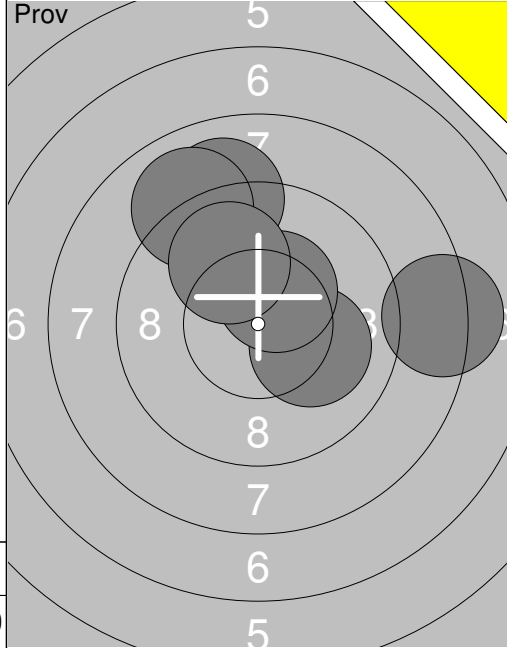

11: 8.2	➔
12: 9.0	↑
13: 9.0	↖
14: 10.1	➔
15: 10.4	✕
16: 9.9	↖
Serie	56.6
Total	0.0

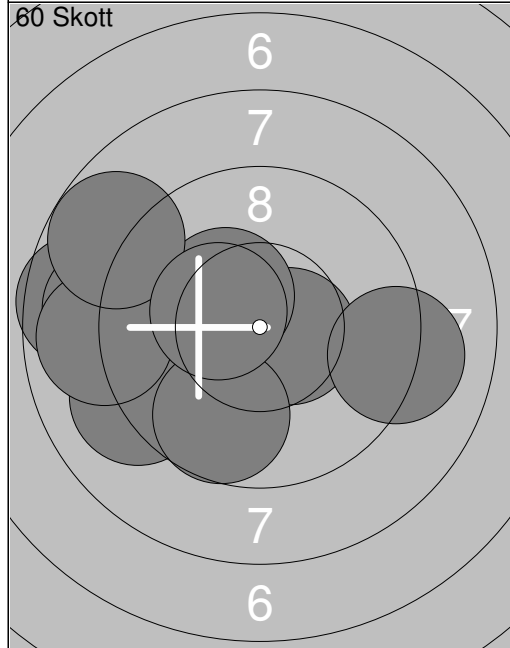

1: 8.6	↖
2: 10.6	✕
3: 9.1	➔
4: 9.1	↖
5: 9.7	↘
6: 9.0	↖
7: 10.4	✕
8: 8.9	↖
9: 8.8	↖
10: 10.4	✕
Serie	94.6
Total	94.6

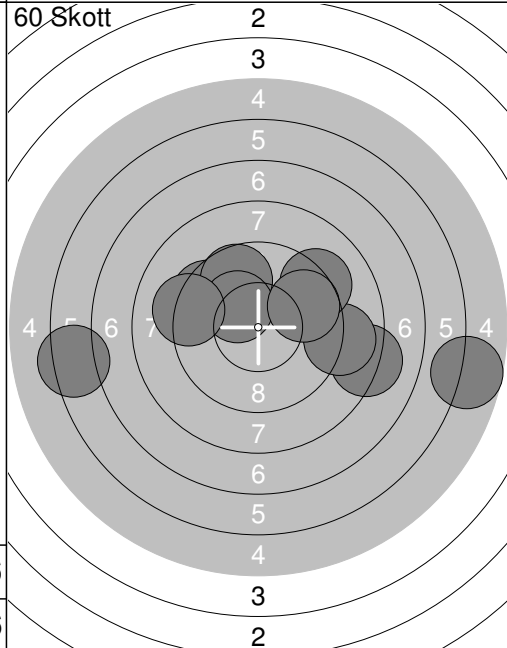

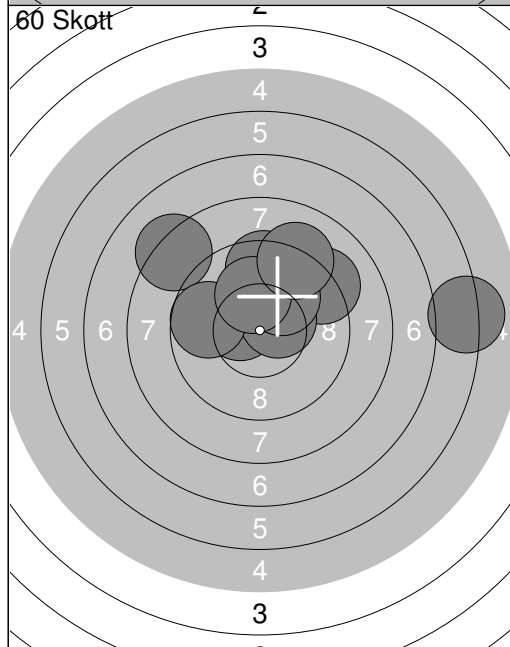

11: 8.2	➔
12: 5.7	➔
13: 9.5	↖
14: 6.3	↖
15: 9.7	↖
16: 10.3	✕
17: 8.9	➔
18: 9.2	↗
19: 9.2	↖
20: 9.7	↗
Serie	86.7
Total	181.3

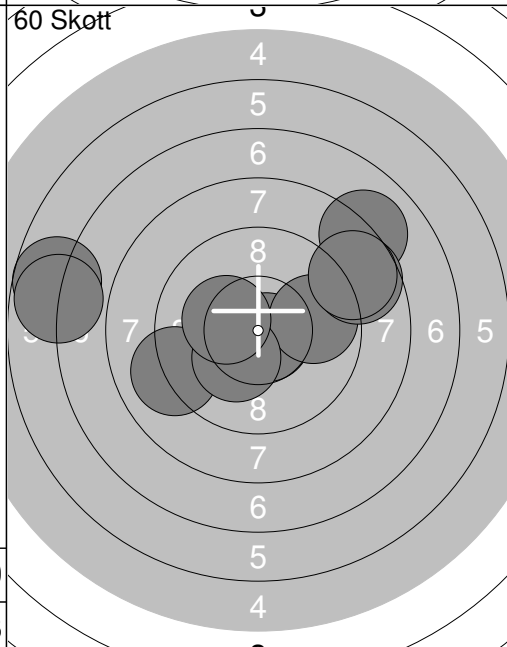

21: 8.3	↖
22: 6.1	➔
23: 9.5	↑
24: 10.5	✕
25: 9.2	↗
26: 10.5	✕
27: 10.0	↖
28: 9.7	↖
29: 10.1	↑
30: 9.1	↖
Serie	93.0
Total	274.3

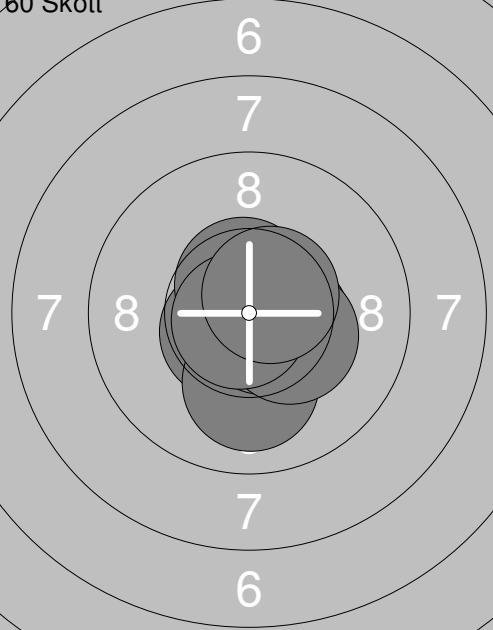
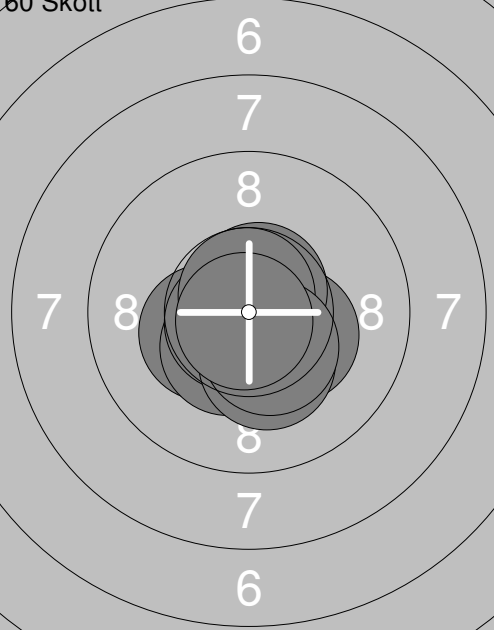

31: 9.1	↖
32: 8.1	↗
33: 6.8	↖
34: 10.7	✕
35: 9.8	➔
36: 10.2	✕
37: 8.7	↗
38: 6.8	↖
39: 10.3	✕
40: 8.7	↗
Serie	89.2
Total	363.5

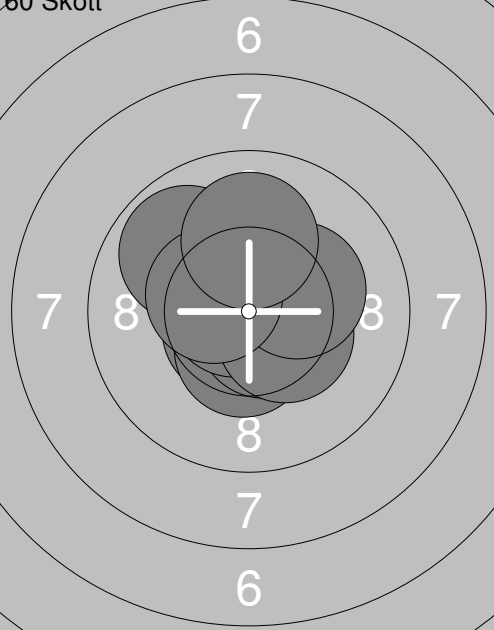
<p>Prov</p> 	<p>60 Skott</p> 	
<p>1: 10.5x↖</p> <p>2: 10.5x↘</p> <p>3: 10.8x↓</p> <p>4: 10.2x↘</p> <p>5: 10.5x↘</p> <p>6: 10.7x↖</p> <p>7: 10.4x↖</p> <p>8: 10.9x↖</p>	<p>1: 10.6x↘</p> <p>2: 10.4x↓</p> <p>3: 10.3x↓</p> <p>4: 10.5x➤</p> <p>5: 10.0 ↓</p> <p>6: 10.7x↘</p> <p>7: 10.3x➤</p> <p>8: 10.6x↗</p> <p>9: 10.8x↘</p> <p>10: 10.6x↗</p>	
Serie 84.5	Serie 104.8	
Total 0.0	Total 104.8	
<p>60 Skott</p> 	<p>60 Skott</p> 	
<p>11: 10.3x➤</p> <p>12: 10.3x↖</p> <p>13: 10.4x↓</p> <p>14: 10.7x↓</p> <p>15: 10.6x↗</p> <p>16: 10.7x↖</p> <p>17: 10.3x↓</p> <p>18: 10.7x↗</p> <p>19: 10.4x↓</p> <p>20: 10.8x↓</p>	<p>21: 10.4x↓</p> <p>22: 10.5x➤</p> <p>23: 10.7x➤</p> <p>24: 10.8x↘</p> <p>25: 10.3x↓</p> <p>26: 10.5x➤</p> <p>27: 10.2x↓</p> <p>28: 10.1 ↓</p> <p>29: 10.7x↖</p> <p>30: 10.5x➤</p>	
Serie 105.2	Serie 104.7	
Total 210.0	Total 314.7	
<p>60 Skott</p> 	<p>31: 10.6x↘</p> <p>32: 10.6x↗</p> <p>33: 10.5x↓</p> <p>34: 10.6x↘</p> <p>35: 9.9 ↖</p> <p>36: 10.8x↖</p> <p>37: 10.4x➤</p> <p>38: 10.3x➤</p> <p>39: 10.4x↖</p> <p>40: 10.0 ↑</p>	
Serie 104.1		
Total 418.8		

<p>Prov</p>	<p>1: 10.3x ↘ 2: 9.8 ↘ 3: 10.7x ↘ 4: 10.1 ↘ 5: 10.2x ↘ 6: 10.1 → 7: 10.6x ↘ 8: 10.3x ↘ 9: 10.6x ↘ 10: 10.4x ↘</p> <p>Serie 103.1 Total 0.0</p>	<p>Prov</p>	<p>11: 10.4x ↘ 12: 9.8 ↘ 13: 10.7x ↘ 14: 9.8 ← 15: 10.0 ↗ 16: 10.9x ↗ 17: 9.9 ← 18: 10.1 ↗</p> <p>Serie 81.6 Total 0.0</p>
-------------	--	-------------	--

<p>60 Skott</p>	<p>1: 9.9 → 2: 9.5 ↗ 3: 10.3x ↘ 4: 10.2x ↘ 5: 10.1 ↘ 6: 10.5x ↘ 7: 10.7x ↘ 8: 10.4x ↘ 9: 10.7x ↗ 10: 9.7 →</p> <p>Serie 102.0 Total 102.0</p>	<p>60 Skott</p>	<p>11: 10.2x ↘ 12: 9.8 ↗ 13: 10.7x ↗ 14: 9.8 ↘ 15: 10.2x ↘ 16: 10.3x ↗ 17: 10.6x ↘ 18: 10.6x ↘ 19: 10.1 → 20: 10.7x ↗</p> <p>Serie 103.0 Total 205.0</p>
-----------------	---	-----------------	--

<p>60 Skott</p>	<p>21: 10.4x ↘ 22: 10.2x → 23: 10.5x ↘ 24: 10.3x ↗ 25: 10.0 → 26: 10.9x ↘ 27: 9.8 ↗ 28: 10.5x ↘ 29: 10.3x → 30: 10.4x →</p> <p>Serie 103.3 Total 308.3</p>	<p>60 Skott</p>	<p>31: 9.5 ← 32: 10.5x ↘ 33: 10.3x ↘ 34: 10.5x ↘ 35: 10.6x ↘ 36: 10.6x ↗ 37: 10.5x ↗ 38: 10.5x ↗ 39: 10.4x ↘ 40: 10.7x ↘</p> <p>Serie 104.1 Total 412.4</p>
-----------------	--	-----------------	---

<p>Prov</p>	<p>1: 10.7x↗ 2: 10.8x↗ 3: 10.4x↗ 4: 9.8 → 5: 10.5x↑ 6: 10.6x→ 7: 10.2x↗ 8: 9.8 ← 9: 10.4x↗ 10: 10.4x←</p> <p>Serie 103.6 Total 0.0</p>	<p>Prov</p>	<p>11: 10.6x←</p> <p>Serie 10.6 Total 0.0</p>
<p>60 Skott</p>	<p>1: 10.6x← 2: 10.4x↘ 3: 9.8 ↓ 4: 10.1 ↘ 5: 10.0 ← 6: 9.8 ↘ 7: 10.0 ↑ 8: 10.5x↓ 9: 10.3x← 10: 10.7x←</p> <p>Serie 102.2 Total 102.2</p>	<p>60 Skott</p>	<p>11: 10.1 ↖ 12: 10.7x→ 13: 10.7x↘ 14: 10.6x↓ 15: 10.1 ↑ 16: 10.8x← 17: 10.3x→ 18: 10.5x↓ 19: 10.8x↘ 20: 10.3x↘</p> <p>Serie 104.9 Total 207.1</p>
<p>60 Skott</p>	<p>21: 9.8 ↖ 22: 10.9x← 23: 10.3x↑ 24: 10.2x↗ 25: 10.6x→ 26: 10.6x↓ 27: 10.5x← 28: 10.2x→ 29: 10.7x↗ 30: 10.6x↓</p> <p>Serie 104.4 Total 311.5</p>	<p>60 Skott</p>	<p>31: 10.2x↗ 32: 10.3x↗ 33: 10.5x↘ 34: 10.7x↗ 35: 10.5x↗ 36: 10.1 ↓ 37: 10.5x↗ 38: 10.2x→ 39: 10.4x↗ 40: 9.9 ↑</p> <p>Serie 103.3 Total 414.8</p>



<p>Prov</p>	<p>1: 9.2 ↗ 2: 9.7 ↗ 3: 10.6x ↘ 4: 10.7x ↘ 5: 10.0 ↘ 6: 10.7x ↗ 7: 10.6x ↘ 8: 10.5x ↘ 9: 9.9 ↘ 10: 10.6x ➔</p> <p>Serie 102.5 Total 0.0</p>	<p>Prov</p>	<p>12: 10.2x ↘ 13: 10.8x ➔ 14: 10.3x ↗ 15: 10.2x ➔ 16: 10.4x ↘ 17: 10.3x ↘</p> <p>Serie 62.2 Total 0.0</p>
<p>60 Skott</p>	<p>1: 10.8x ↘ 2: 10.4x ↘ 3: 10.4x ➔ 4: 10.5x ↗ 5: 10.7x ➔ 6: 10.6x ↘ 7: 9.6 ↘ 8: 10.6x ↘ 9: 10.2x ↘ 10: 10.2x ↘</p> <p>Serie 104.0 Total 104.0</p>	<p>60 Skott</p>	<p>11: 10.1 ↘ 12: 10.0 ↘ 13: 10.8x ↘ 14: 10.7x ↘ 15: 10.5x ↘ 16: 9.7 ↗ 17: 10.6x ↘ 18: 10.3x ↘ 19: 10.6x ↗ 20: 10.4x ↗</p> <p>Serie 103.7 Total 207.7</p>
<p>60 Skott</p>	<p>21: 10.8x ↗ 22: 10.4x ↗ 23: 10.6x ↘ 24: 10.1 ↘ 25: 10.5x ↘ 26: 10.4x ↗ 27: 10.4x ➔ 28: 10.4x ↘ 29: 10.7x ➔ 30: 10.0 ↗</p> <p>Serie 104.3 Total 312.0</p>	<p>60 Skott</p>	<p>31: 10.4x ↘ 32: 10.9x ↗ 33: 10.2x ↗ 34: 10.2x ↘ 35: 10.7x ↘ 36: 10.4x ↘ 37: 10.6x ↗ 38: 9.8 ↗ 39: 10.6x ↗ 40: 10.0 ↘</p> <p>Serie 103.8 Total 415.8</p>

<p>Pröv</p>	<table border="1" style="width:100%; border-collapse: collapse;"> <tr><td>1:</td><td>9.7</td><td>→</td></tr> <tr><td>2:</td><td>9.3</td><td>↙</td></tr> <tr><td>3:</td><td>9.9</td><td>↙</td></tr> <tr><td>4:</td><td>10.9x</td><td>→</td></tr> <tr><td>5:</td><td>10.2x</td><td>↙</td></tr> <tr><td>6:</td><td>10.0</td><td>↙</td></tr> <tr><td>7:</td><td>10.8x</td><td>↘</td></tr> <tr><td>8:</td><td>10.0</td><td>↙</td></tr> <tr><td>9:</td><td>10.5x</td><td>←</td></tr> <tr><td>10:</td><td>10.3x</td><td>↓</td></tr> <tr><td colspan="2">Serie</td><td style="text-align: right;">101.6</td></tr> <tr><td colspan="2">Total</td><td style="text-align: right;">0.0</td></tr> </table>	1:	9.7	→	2:	9.3	↙	3:	9.9	↙	4:	10.9x	→	5:	10.2x	↙	6:	10.0	↙	7:	10.8x	↘	8:	10.0	↙	9:	10.5x	←	10:	10.3x	↓	Serie		101.6	Total		0.0	<p>Pröv</p>	<table border="1" style="width:100%; border-collapse: collapse;"> <tr><td>11:</td><td>9.9</td><td>↓</td></tr> <tr><td>12:</td><td>10.3x</td><td>↙</td></tr> <tr><td>13:</td><td>10.1</td><td>↓</td></tr> <tr><td>14:</td><td>10.3x</td><td>↙</td></tr> <tr><td>15:</td><td>10.5x</td><td>←</td></tr> <tr><td>16:</td><td>10.0</td><td>←</td></tr> <tr><td>17:</td><td>9.9</td><td>↗</td></tr> <tr><td>18:</td><td>10.2x</td><td>↗</td></tr> <tr><td>19:</td><td>10.6x</td><td>↘</td></tr> <tr><td>20:</td><td>10.3x</td><td>←</td></tr> <tr><td colspan="2">Serie</td><td style="text-align: right;">102.1</td></tr> <tr><td colspan="2">Total</td><td style="text-align: right;">0.0</td></tr> </table>	11:	9.9	↓	12:	10.3x	↙	13:	10.1	↓	14:	10.3x	↙	15:	10.5x	←	16:	10.0	←	17:	9.9	↗	18:	10.2x	↗	19:	10.6x	↘	20:	10.3x	←	Serie		102.1	Total		0.0
1:	9.7	→																																																																									
2:	9.3	↙																																																																									
3:	9.9	↙																																																																									
4:	10.9x	→																																																																									
5:	10.2x	↙																																																																									
6:	10.0	↙																																																																									
7:	10.8x	↘																																																																									
8:	10.0	↙																																																																									
9:	10.5x	←																																																																									
10:	10.3x	↓																																																																									
Serie		101.6																																																																									
Total		0.0																																																																									
11:	9.9	↓																																																																									
12:	10.3x	↙																																																																									
13:	10.1	↓																																																																									
14:	10.3x	↙																																																																									
15:	10.5x	←																																																																									
16:	10.0	←																																																																									
17:	9.9	↗																																																																									
18:	10.2x	↗																																																																									
19:	10.6x	↘																																																																									
20:	10.3x	←																																																																									
Serie		102.1																																																																									
Total		0.0																																																																									
<p>Pröv</p>	<table border="1" style="width:100%; border-collapse: collapse;"> <tr><td>21:</td><td>10.3x</td><td>↘</td></tr> <tr><td>22:</td><td>9.6</td><td>↘</td></tr> <tr><td>23:</td><td>9.7</td><td>↗</td></tr> <tr><td>24:</td><td>9.4</td><td>←</td></tr> <tr><td>25:</td><td>10.4x</td><td>←</td></tr> <tr><td>26:</td><td>10.2x</td><td>←</td></tr> <tr><td>27:</td><td>10.8x</td><td>↓</td></tr> <tr><td colspan="2">Serie</td><td style="text-align: right;">70.4</td></tr> <tr><td colspan="2">Total</td><td style="text-align: right;">0.0</td></tr> </table>	21:	10.3x	↘	22:	9.6	↘	23:	9.7	↗	24:	9.4	←	25:	10.4x	←	26:	10.2x	←	27:	10.8x	↓	Serie		70.4	Total		0.0	<p>60 Skott</p>	<table border="1" style="width:100%; border-collapse: collapse;"> <tr><td>1:</td><td>10.7x</td><td>←</td></tr> <tr><td>2:</td><td>10.0</td><td>←</td></tr> <tr><td>3:</td><td>10.3x</td><td>↙</td></tr> <tr><td>4:</td><td>10.1</td><td>↗</td></tr> <tr><td>5:</td><td>10.6x</td><td>↑</td></tr> <tr><td>6:</td><td>10.2x</td><td>↙</td></tr> <tr><td>7:</td><td>9.7</td><td>↓</td></tr> <tr><td>8:</td><td>10.6x</td><td>↗</td></tr> <tr><td>9:</td><td>9.9</td><td>←</td></tr> <tr><td>10:</td><td>10.2x</td><td>↓</td></tr> <tr><td colspan="2">Serie</td><td style="text-align: right;">102.3</td></tr> <tr><td colspan="2">Total</td><td style="text-align: right;">102.3</td></tr> </table>	1:	10.7x	←	2:	10.0	←	3:	10.3x	↙	4:	10.1	↗	5:	10.6x	↑	6:	10.2x	↙	7:	9.7	↓	8:	10.6x	↗	9:	9.9	←	10:	10.2x	↓	Serie		102.3	Total		102.3									
21:	10.3x	↘																																																																									
22:	9.6	↘																																																																									
23:	9.7	↗																																																																									
24:	9.4	←																																																																									
25:	10.4x	←																																																																									
26:	10.2x	←																																																																									
27:	10.8x	↓																																																																									
Serie		70.4																																																																									
Total		0.0																																																																									
1:	10.7x	←																																																																									
2:	10.0	←																																																																									
3:	10.3x	↙																																																																									
4:	10.1	↗																																																																									
5:	10.6x	↑																																																																									
6:	10.2x	↙																																																																									
7:	9.7	↓																																																																									
8:	10.6x	↗																																																																									
9:	9.9	←																																																																									
10:	10.2x	↓																																																																									
Serie		102.3																																																																									
Total		102.3																																																																									
<p>60 Skott</p>	<table border="1" style="width:100%; border-collapse: collapse;"> <tr><td>11:</td><td>10.0</td><td>←</td></tr> <tr><td>12:</td><td>10.6x</td><td>←</td></tr> <tr><td>13:</td><td>10.4x</td><td>↓</td></tr> <tr><td>14:</td><td>10.6x</td><td>↘</td></tr> <tr><td>15:</td><td>10.0</td><td>←</td></tr> <tr><td>16:</td><td>10.4x</td><td>←</td></tr> <tr><td>17:</td><td>10.0</td><td>↓</td></tr> <tr><td>18:</td><td>10.3x</td><td>↗</td></tr> <tr><td>19:</td><td>10.4x</td><td>↗</td></tr> <tr><td>20:</td><td>10.1</td><td>↙</td></tr> <tr><td colspan="2">Serie</td><td style="text-align: right;">102.8</td></tr> <tr><td colspan="2">Total</td><td style="text-align: right;">205.1</td></tr> </table>	11:	10.0	←	12:	10.6x	←	13:	10.4x	↓	14:	10.6x	↘	15:	10.0	←	16:	10.4x	←	17:	10.0	↓	18:	10.3x	↗	19:	10.4x	↗	20:	10.1	↙	Serie		102.8	Total		205.1	<p>60 Skott</p>	<table border="1" style="width:100%; border-collapse: collapse;"> <tr><td>21:</td><td>10.4x</td><td>↙</td></tr> <tr><td>22:</td><td>10.7x</td><td>←</td></tr> <tr><td>23:</td><td>10.0</td><td>↓</td></tr> <tr><td>24:</td><td>9.9</td><td>↖</td></tr> <tr><td>25:</td><td>9.5</td><td>↙</td></tr> <tr><td>26:</td><td>10.3x</td><td>↑</td></tr> <tr><td>27:</td><td>10.4x</td><td>↙</td></tr> <tr><td>28:</td><td>10.5x</td><td>←</td></tr> <tr><td>29:</td><td>10.3x</td><td>←</td></tr> <tr><td>30:</td><td>10.3x</td><td>←</td></tr> <tr><td colspan="2">Serie</td><td style="text-align: right;">102.3</td></tr> <tr><td colspan="2">Total</td><td style="text-align: right;">307.4</td></tr> </table>	21:	10.4x	↙	22:	10.7x	←	23:	10.0	↓	24:	9.9	↖	25:	9.5	↙	26:	10.3x	↑	27:	10.4x	↙	28:	10.5x	←	29:	10.3x	←	30:	10.3x	←	Serie		102.3	Total		307.4
11:	10.0	←																																																																									
12:	10.6x	←																																																																									
13:	10.4x	↓																																																																									
14:	10.6x	↘																																																																									
15:	10.0	←																																																																									
16:	10.4x	←																																																																									
17:	10.0	↓																																																																									
18:	10.3x	↗																																																																									
19:	10.4x	↗																																																																									
20:	10.1	↙																																																																									
Serie		102.8																																																																									
Total		205.1																																																																									
21:	10.4x	↙																																																																									
22:	10.7x	←																																																																									
23:	10.0	↓																																																																									
24:	9.9	↖																																																																									
25:	9.5	↙																																																																									
26:	10.3x	↑																																																																									
27:	10.4x	↙																																																																									
28:	10.5x	←																																																																									
29:	10.3x	←																																																																									
30:	10.3x	←																																																																									
Serie		102.3																																																																									
Total		307.4																																																																									
<p>60 Skott</p>	<table border="1" style="width:100%; border-collapse: collapse;"> <tr><td>31:</td><td>9.2</td><td>↙</td></tr> <tr><td>32:</td><td>10.0</td><td>←</td></tr> <tr><td>33:</td><td>10.2x</td><td>↗</td></tr> <tr><td>34:</td><td>9.5</td><td>↙</td></tr> <tr><td>35:</td><td>9.9</td><td>↖</td></tr> <tr><td>36:</td><td>10.0</td><td>↗</td></tr> <tr><td>37:</td><td>10.7x</td><td>↗</td></tr> <tr><td>38:</td><td>10.7x</td><td>↗</td></tr> <tr><td>39:</td><td>9.4</td><td>←</td></tr> <tr><td>40:</td><td>10.0</td><td>↗</td></tr> <tr><td colspan="2">Serie</td><td style="text-align: right;">99.6</td></tr> <tr><td colspan="2">Total</td><td style="text-align: right;">407.0</td></tr> </table>	31:	9.2	↙	32:	10.0	←	33:	10.2x	↗	34:	9.5	↙	35:	9.9	↖	36:	10.0	↗	37:	10.7x	↗	38:	10.7x	↗	39:	9.4	←	40:	10.0	↗	Serie		99.6	Total		407.0																																						
31:	9.2	↙																																																																									
32:	10.0	←																																																																									
33:	10.2x	↗																																																																									
34:	9.5	↙																																																																									
35:	9.9	↖																																																																									
36:	10.0	↗																																																																									
37:	10.7x	↗																																																																									
38:	10.7x	↗																																																																									
39:	9.4	←																																																																									
40:	10.0	↗																																																																									
Serie		99.6																																																																									
Total		407.0																																																																									

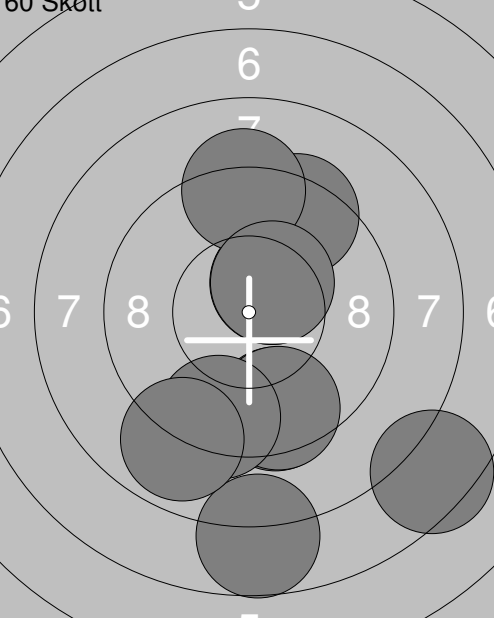
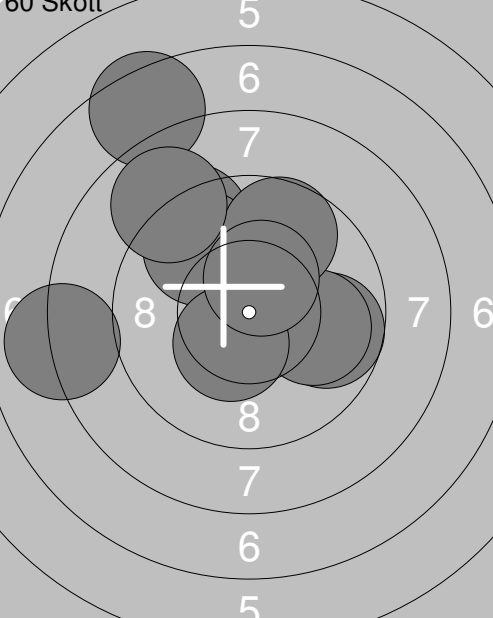
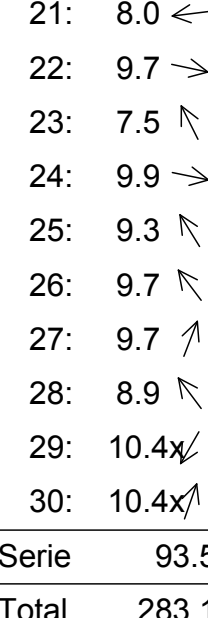

<p>Pröv</p>	<p>1: 10.2x ↓ 2: 9.9 ↓ 3: 10.6x ↓ 4: 10.7x → 5: 10.2x ↑ 6: 10.5x ← 7: 10.3x ↑ 8: 10.4x → 9: 9.7 ← 10: 10.2x ↓</p> <p>Serie 102.7 Total 0.0</p>	<p>Pröv</p>	<p>11: 10.3x ↓ 12: 10.5x ↑ 13: 10.6x ↑ 14: 10.0 ← 15: 10.3x ↑ 16: 10.2x ↑ 17: 10.7x ← 18: 10.3x ↓ 19: 10.2x ↓ 20: 10.2x ↓</p> <p>Serie 103.3 Total 0.0</p>
<p>Pröv</p>	<p>21: 10.4x ↓ 22: 10.2x ↗</p> <p>Serie 20.6 Total 0.0</p>	<p>60 Skott</p>	<p>1: 10.4x ← 2: 10.4x ↓ 3: 10.5x ↑ 4: 10.5x ↗ 5: 10.2x ↑ 6: 10.0 ↗ 7: 10.4x → 8: 10.0 → 9: 10.5x → 10: 10.8x →</p> <p>Serie 103.7 Total 103.7</p>
<p>60 Skott</p>	<p>11: 10.7x ← 12: 10.1 ↗ 13: 10.0 ↑ 14: 10.2x ↑ 15: 10.7x ↑ 16: 10.6x ↓ 17: 10.4x ↑ 18: 10.6x ↓ 19: 10.0 ← 20: 10.7x ↑</p> <p>Serie 104.0 Total 207.7</p>	<p>60 Skott</p>	<p>21: 10.9x ↗ 22: 10.4x ↗ 23: 10.1 ↗ 24: 10.6x ↑ 25: 10.5x → 26: 10.4x ↗ 27: 9.9 ↗ 28: 10.7x ← 29: 10.5x ← 30: 10.5x ←</p> <p>Serie 104.5 Total 312.2</p>
<p>60 Skott</p>	<p>31: 10.1 ↑ 32: 10.3x ↑ 33: 10.9x ← 34: 10.3x ← 35: 10.7x ← 36: 10.5x ↗ 37: 10.8x ↑ 38: 10.3x → 39: 10.4x ↓ 40: 10.6x →</p> <p>Serie 104.9 Total 417.1</p>		

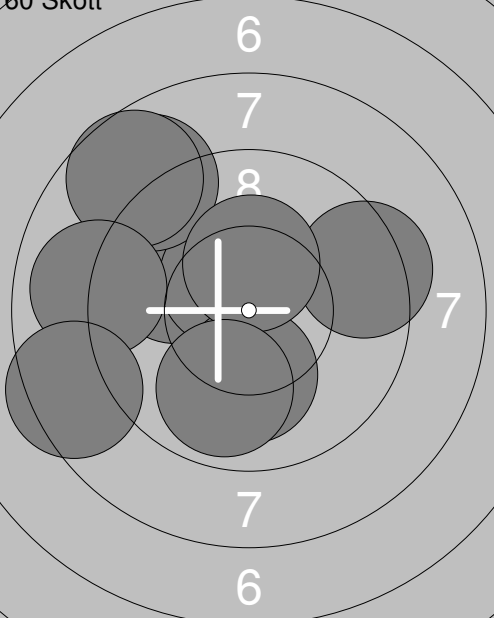
<p>Prov</p> 	<p>60 Skott</p> 	<p>60 Skott</p> 
<p>1: 9.9 →</p> <p>2: 9.4 →</p> <p>3: 9.6 ↓</p> <p>4: 9.9 ←</p> <p>5: 7.8 ↑</p> <p>6: 9.9 ←</p> <p>7: 10.3x ↗</p> <p>8: 8.1 ↗</p> <p>9: 9.0 ↖</p> <p>10: 9.9 ↗</p>	<p>1: 10.5x ↗</p> <p>2: 8.5 ↖</p> <p>3: 9.3 ↗</p> <p>4: 9.2 ←</p> <p>5: 8.5 ↗</p> <p>6: 10.3x ↘</p> <p>7: 10.6x ↖</p> <p>8: 10.5x ↗</p> <p>9: 10.8x ↘</p> <p>10: 9.6 ↗</p>	
Serie 93.8	Serie 97.8	Serie 97.8
Total 0.0	Total 97.8	Total 97.8

<p>60 Skott</p> 	<p>60 Skott</p> 	<p>60 Skott</p> 
<p>11: 10.4x ↗</p> <p>12: 9.5 ↓</p> <p>13: 9.5 ↓</p> <p>14: 9.4 ↗</p> <p>15: 9.4 ↓</p> <p>16: 7.7 ↓</p> <p>17: 8.9 ↓</p> <p>18: 7.4 ↓</p> <p>19: 9.2 ↑</p> <p>20: 10.4x ↗</p>	<p>21: 8.0 ←</p> <p>22: 9.7 →</p> <p>23: 7.5 ↗</p> <p>24: 9.9 →</p> <p>25: 9.3 ↗</p> <p>26: 9.7 ↖</p> <p>27: 9.7 ↗</p> <p>28: 8.9 ↖</p> <p>29: 10.4x ↘</p> <p>30: 10.4x ↗</p>	
Serie 91.8	Serie 93.5	Serie 93.5
Total 189.6	Total 283.1	Total 283.1

<p>60 Skott</p> 	<p>60 Skott</p> 	<p>60 Skott</p> 
<p>31: 9.4 →</p> <p>32: 9.9 ←</p> <p>33: 10.5x ↗</p> <p>34: 8.8 ↖</p> <p>35: 10.1 ↓</p> <p>36: 10.3x ↗</p> <p>37: 8.7 ↖</p> <p>38: 9.9 ↓</p> <p>39: 9.0 ←</p> <p>40: 8.5 ←</p>		
Serie 95.1		
Total 378.2		

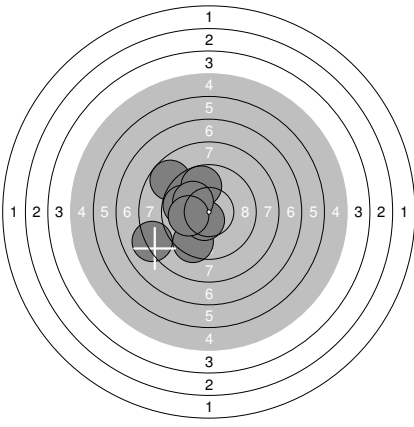
<p>Prov</p>	<p>1: 10.0 ↘ 2: 10.0 ← 3: 9.9 ← 4: 9.3 ← 5: 10.2x → 6: 10.5x ↘ 7: 9.9 ↘ 8: 9.9 ↘ 9: 10.3x ↗ 10: 10.2x ↘</p> <p>Serie 100.2 Total 0.0</p>	<p>Prov</p>	<p>11: 10.1 → 12: 9.6 ← 13: 10.9x ← 14: 10.0 ↓ 15: 9.4 → 16: 10.0 ← 17: 9.7 ← 18: 10.8x ↓ 19: 9.7 →</p> <p>Serie 90.2 Total 0.0</p>
<p>60 Skott</p>	<p>1: 10.2x ↘ 2: 10.1 → 3: 10.5x ↗ 4: 10.7x ↘ 5: 10.5x ↘ 6: 10.0 ↓ 7: 10.6x ↘ 8: 10.3x ↘ 9: 10.3x ↓ 10: 10.5x ↘</p> <p>Serie 103.7 Total 103.7</p>	<p>60 Skott</p>	<p>11: 10.4x ↘ 12: 10.1 → 13: 10.2x ↓ 14: 9.8 ↗ 15: 9.9 ↗ 16: 8.8 ← 17: 10.5x ← 18: 10.6x ↘ 19: 9.9 ↗ 20: 9.9 ↘</p> <p>Serie 100.1 Total 203.8</p>
<p>60 Skott</p>	<p>21: 9.9 ← 22: 10.3x ↘ 23: 9.2 ↗ 24: 10.2x ↗ 25: 10.5x ↓ 26: 10.5x ↗ 27: 10.0 ↓ 28: 10.5x ↘ 29: 9.7 ← 30: 9.9 ↗</p> <p>Serie 100.7 Total 304.5</p>	<p>60 Skott</p>	<p>31: 10.3x ↘ 32: 9.9 ↓ 33: 9.8 ← 34: 10.2x ↘ 35: 9.7 ← 36: 10.6x → 37: 10.5x ↘ 38: 10.4x ↗ 39: 9.2 ↓ 40: 9.9 ↓</p> <p>Serie 100.5 Total 405.0</p>

Prov 	1: 8.7 ↖ 2: 9.8 ↑ 3: 10.3✕ 4: 9.8 ← 5: 9.4 ↓ 6: 10.5✕ 7: 10.1 ↖ 8: 8.1 ← 9: 10.0 ← 10: 0.0 ↙ Serie 86.7 Total 0.0	Prov 	11: 9.7 ↑ 12: 10.6✕ Serie 20.3 Total 0.0
---	--	--	---

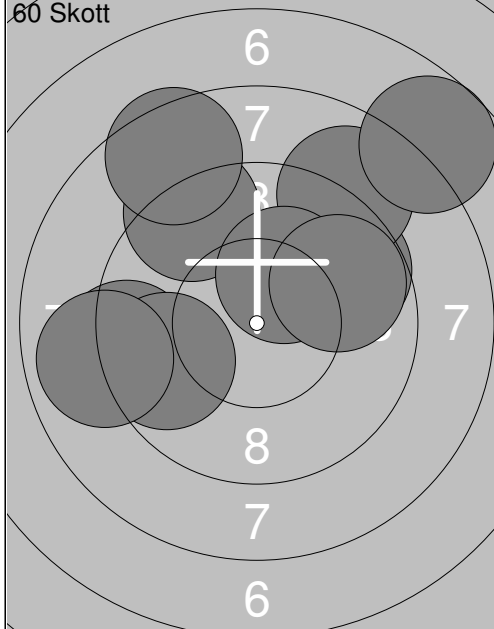
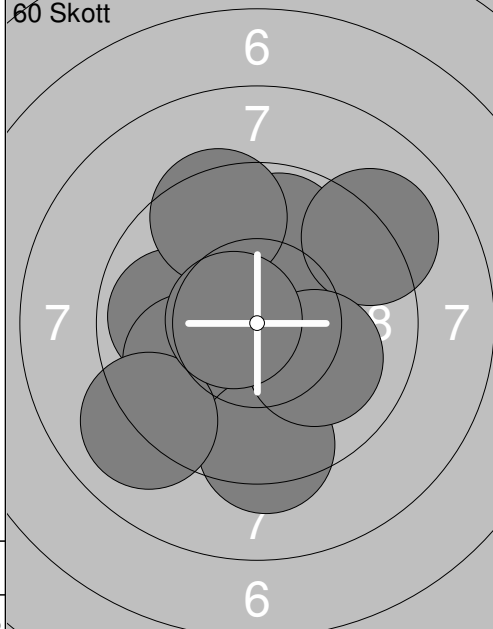
60 Skott 	1: 9.6 ↗ 2: 8.9 ↗ 3: 9.3 ↖ 4: 9.2 ← 5: 7.7 ↗ 6: 10.2✕ 7: 9.7 ← 8: 8.5 ↖ 9: 9.8 ↗ 10: 8.9 ← Serie 91.8 Total 91.8	60 Skott 	11: 10.6✕ 12: 9.8 ↑ 13: 9.9 ← 14: 9.5 ↖ 15: 9.1 ↗ 16: 10.0 ← 17: 9.4 ↓ 18: 10.1 ↘ 19: 9.0 ↙ 20: 10.6✕ Serie 98.0 Total 189.8
---	---	---	---

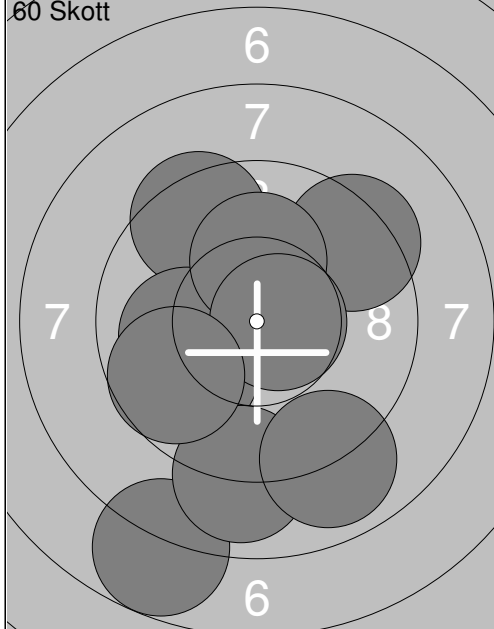
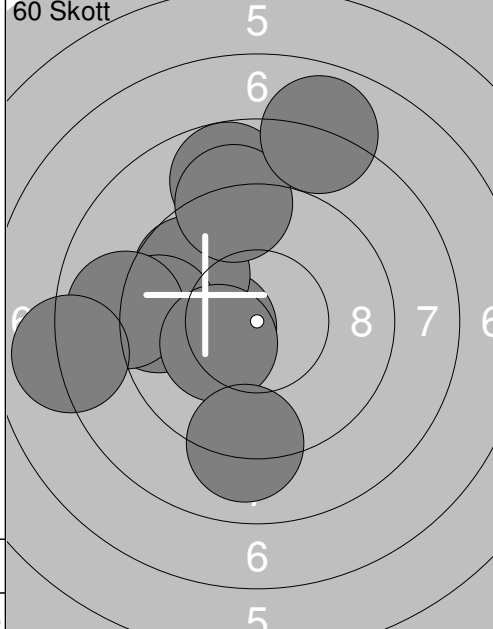
60 Skott 	21: 9.9 ↙ 22: 7.7 ↓ 23: 9.4 ↖ 24: 9.3 ↗ 25: 8.9 ↓ 26: 10.0 ← 27: 10.2✕ 28: 8.9 ↓ 29: 10.7✕ 30: 9.7 ↙ Serie 94.7 Total 284.5	60 Skott 	31: 10.3✕ 32: 9.7 ↖ 33: 9.4 ← 34: 8.9 ← 35: 8.8 ↑ 36: 10.3✕ 37: 9.1 ↑ 38: 7.9 ↗ 39: 8.1 ← 40: 9.1 ↓ Serie 91.6 Total 376.1
--	--	--	---

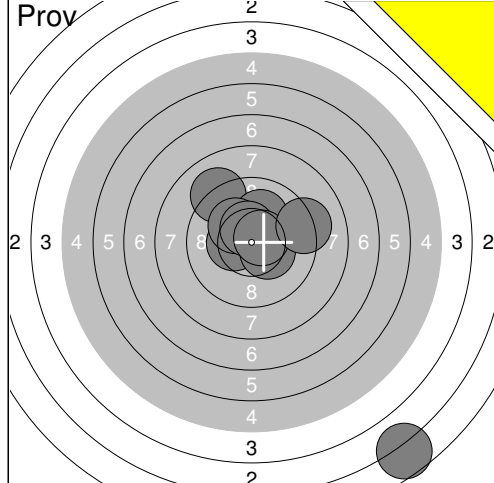

1:	2.6	↘
2:	10.4x	←
3:	9.1	↗
4:	10.1	↗
6:	10.2x	↗
7:	10.4x	↘
8:	10.5x	↗
9:	10.6x	→
10:	9.2	→

Serie	83.1
Total	0.0

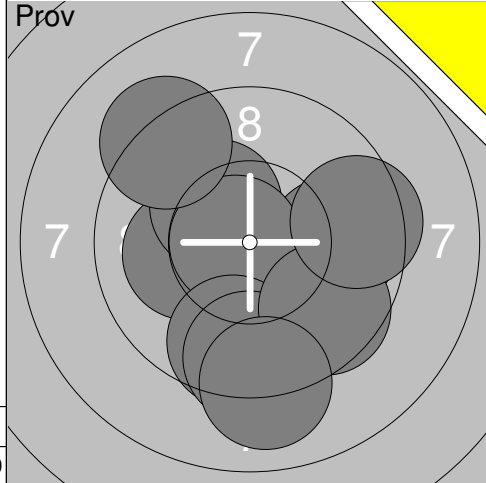

11:	9.8	→
12:	10.1	←
13:	10.3x	↗
14:	10.8x	←
15:	9.6	↘
16:	9.2	↗
17:	9.4	↘
18:	9.6	↘
19:	9.0	↘
20:	9.5	→

Serie	97.3
Total	0.0

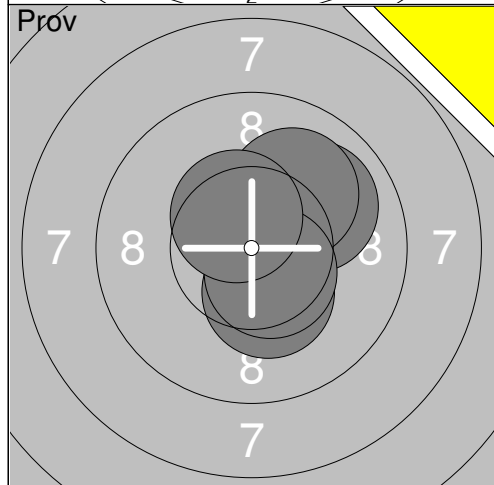

21:	10.4x	↗
22:	10.0	↗
23:	10.0	↗
24:	10.3x	↘
25:	10.5x	↘
26:	10.5x	↗

Serie	61.7
Total	0.0

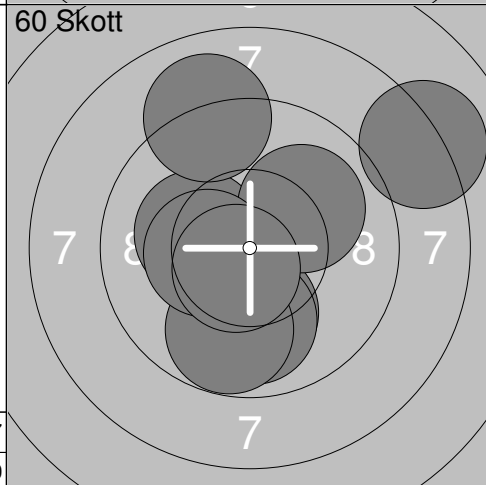

1:	10.0	↘
2:	10.2x	←
3:	10.6x	↙
4:	10.0	↗
5:	9.9	↘
6:	9.8	↘
7:	8.1	↗
8:	10.4x	←
9:	10.6x	↙
10:	9.0	↗

Serie	98.6
Total	98.6

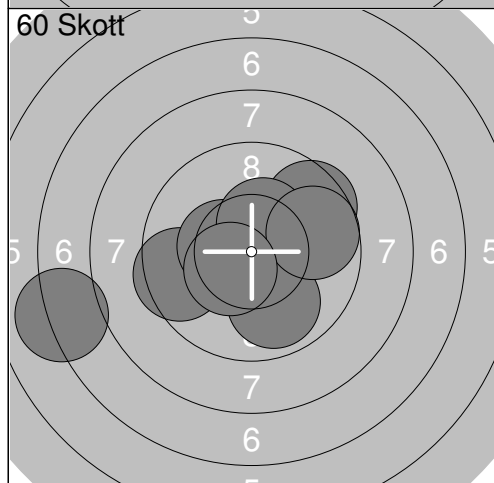

11:	9.5	↗
12:	9.5	←
13:	10.3x	↘
14:	10.4x	←
15:	10.3x	↗
16:	10.4x	↗
17:	9.9	↘
18:	7.1	←
19:	9.7	→
20:	10.4x	↙

Serie	97.5
Total	196.1

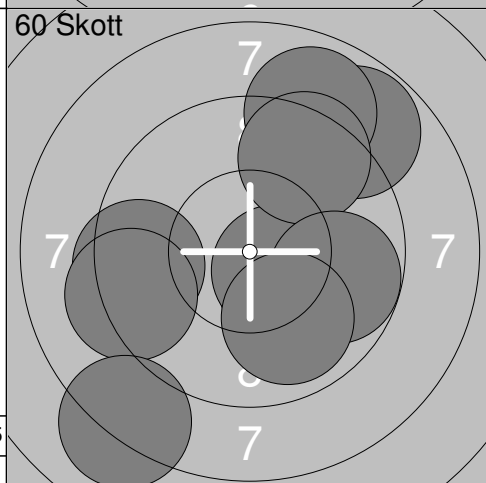

21:	10.2x	↘
22:	8.8	↗
23:	8.9	↗
24:	9.4	←
25:	10.5x	↘
26:	9.5	↗
27:	9.2	←
28:	9.8	→
29:	9.9	↘
30:	8.1	↙

Serie	94.3
Total	290.4

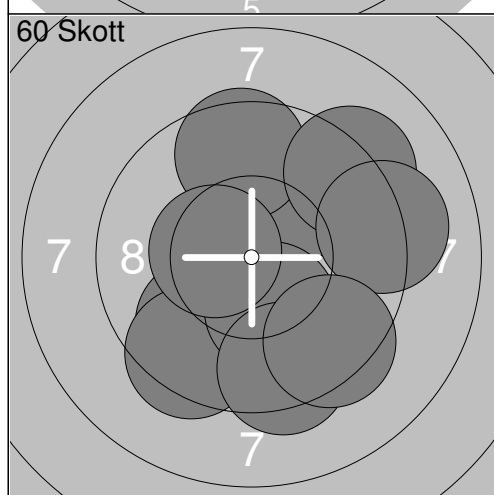

31:	9.8	↙
32:	9.4	↙
33:	9.9	↗
34:	9.6	↗
35:	10.2x	↘
36:	9.2	↗
37:	9.4	↘
38:	9.1	→
39:	9.4	↘
40:	10.4x	←

Serie	96.4
Total	386.8