

1: *10.4 ↙	6: *10.8 ↗	Serie	98.0	1: 10.2 ↓	Serie	49.0
2: *10.5 ↘	7: *10.5 ↗			2: 10.0 ↑		
3: 10.0 ↙	8: 9.7 ↙	Total	189.0	3: 10.0 ↑	Total	238.0
4: 9.6 ↙	9: *10.8 ↗			4: 10.0 ↗		
5: 10.1 ↘	10: 10.0 ↑			5: 9.5 ↓		

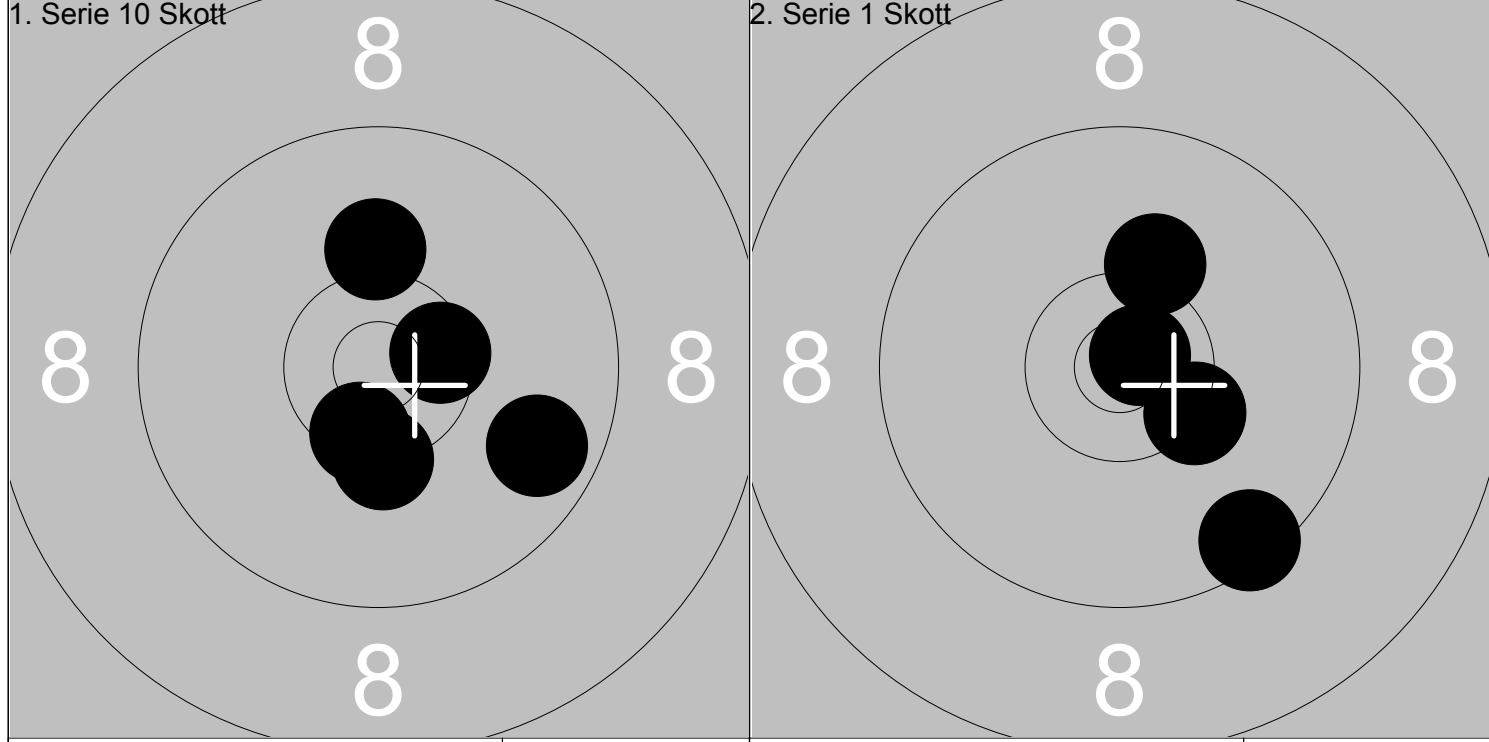
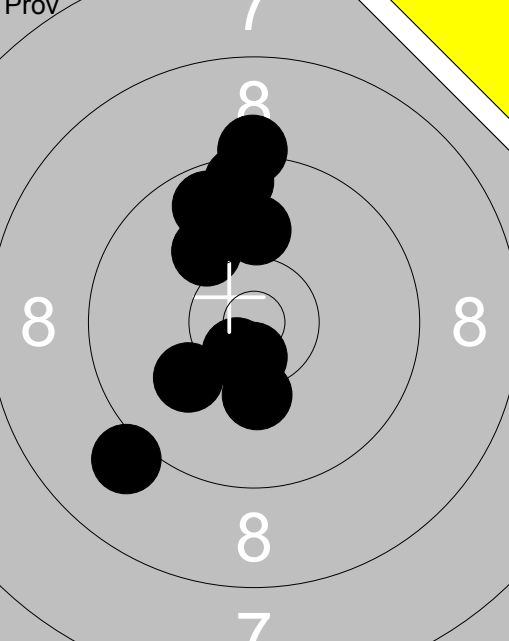
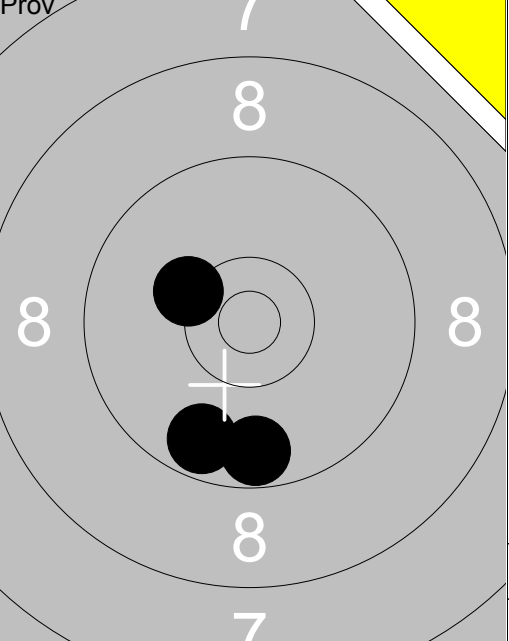
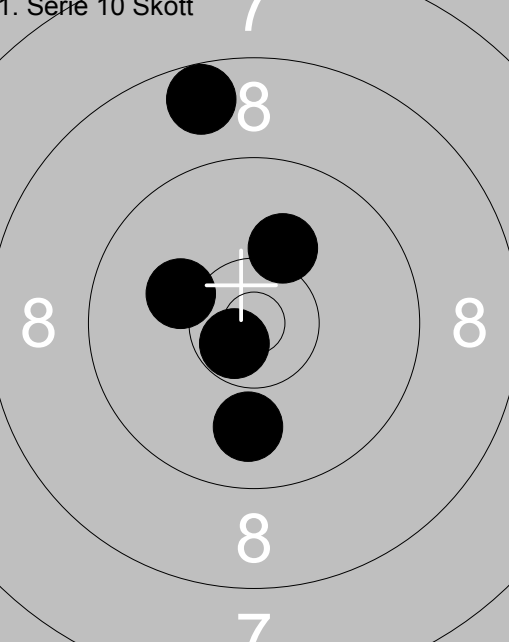
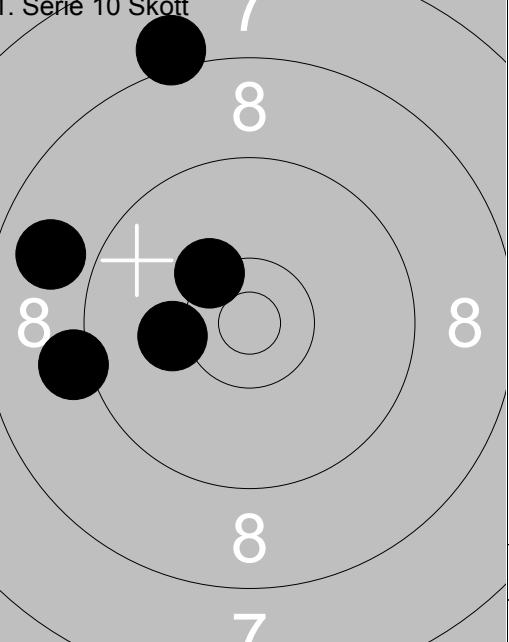

6: *10.5 →	Serie	49.0	1: *10.3 ↘	Serie	49.0
7: 9.7 →			2: 9.5 ↓		
8: *10.3 ↓	Total	287.0	3: 10.2 ↑	Total	336.0
9: *10.5 ↓			4: *10.3 ↘		
10: 10.1 ↑			5: *10.8 ↗		

Prov 	1: 10.0 ↑ 2: 9.5 ↑ 3: *10.6 ↘ 4: 9.2 ↑ 5: *10.6 ↓ 6: 10.1 ↙ 7: 9.1 ↙ 8: 9.7 ↑ 9: 10.2 ↓ 10: 10.1 ↘	Prov 	11: 9.7 ↓ 12: 9.7 ↓ 13: 10.3 ↙
Serie 96.0		Serie 28.0	
Total 189.0		Total 189.0	

1. Serie 10 Skott 	1: 9.9 ↓ 2: 10.2 ↙ 3: 8.7 ↑ 4: *10.7 ↘ 5: 10.1 ↑	1. Serie 10 Skott 	6: 10.2 ↙ 7: 9.1 ↙ 8: 8.1 ↑ 9: *10.3 ↘ 10: 8.8 ↙
Serie 47.0		Serie 45.0	
Total 236.0		Total 281.0	

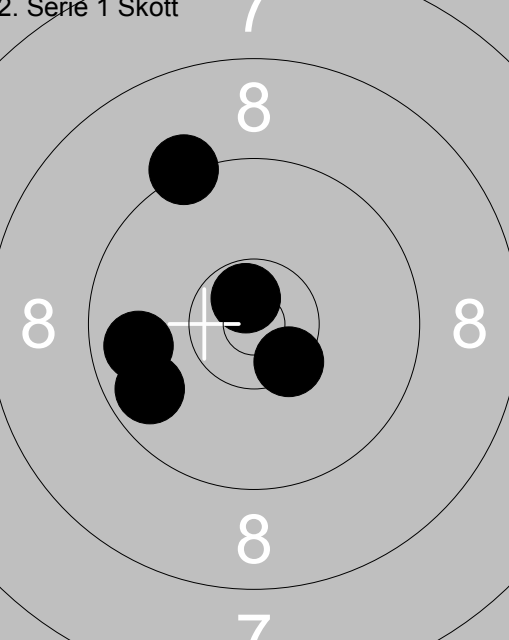
2. Serie 1 Skott 	1: 9.8 ← 2: *10.4 ↘ 3: 9.3 ↑ 4: *10.7 ↘ 5: 9.7 ↙		
Serie 47.0			
Total 328.0			

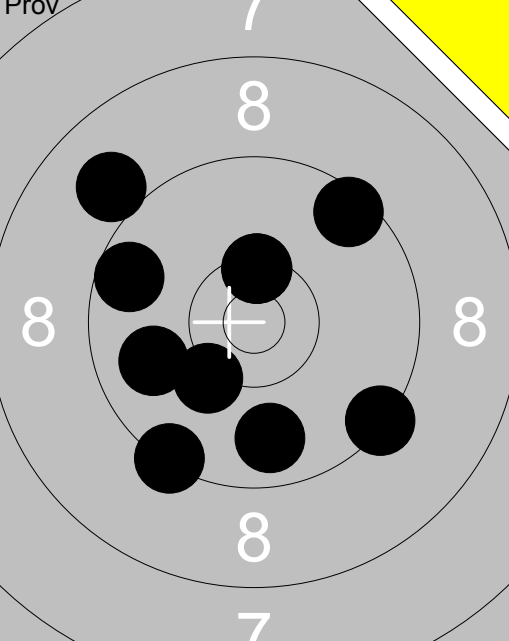
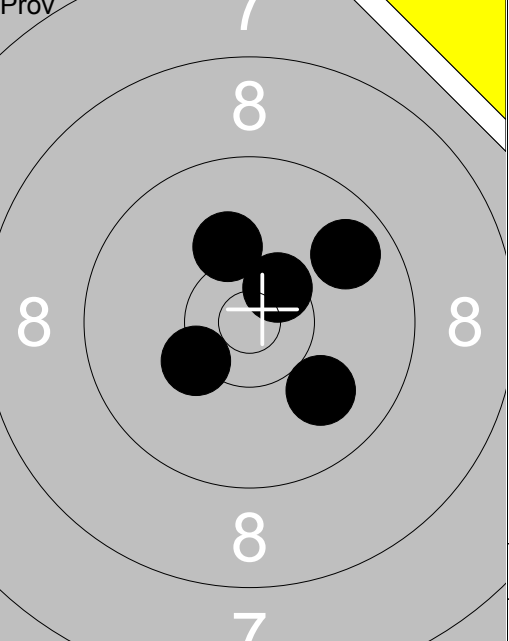
<p>Prov</p> 	<p>1: 9.0 ↙ 2: 9.5 ↗ 3: *10.4↑ 4: 9.9 ← 5: 9.3 → 6: 9.4 ↓ 7: *10.4↑ 8: 10.2↙ 9: 9.8 ↓ 10: 9.6 ←</p> <p>Serie 93.0 Total 185.0</p>	<p>Prov</p>  <p>11: *10.5↗ 12: 10.3↙ 13: 10.2↑ 14: 9.8↗ 15: 10.0↘</p> <p>Serie 49.0 Total 185.0</p>
--	---	--

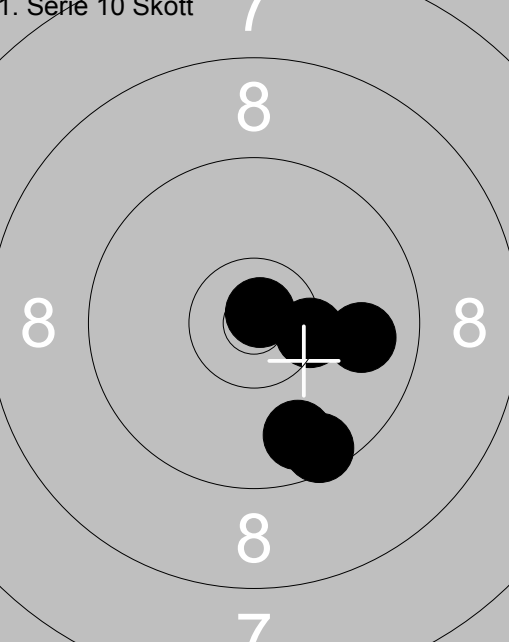
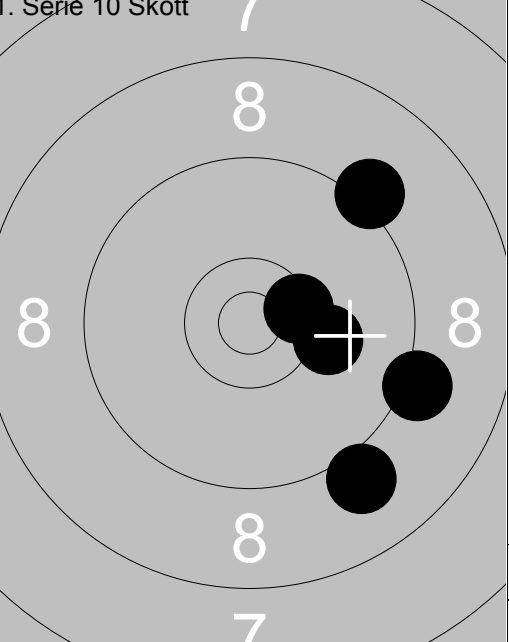
<p>1. Serie 10 Skott</p> 	<p>1: 9.9 → 2: *10.8↗ 3: 9.8 ↓ 4: *10.4→ 5: 9.5 ↓</p> <p>Serie 47.0 Total 232.0</p>	<p>1. Serie 10 Skott</p>  <p>6: 9.0 ↓ 7: 9.2 ↗ 8: 10.2→ 9: 9.2 → 10: *10.4→</p> <p>Serie 47.0 Total 279.0</p>
--	--	---

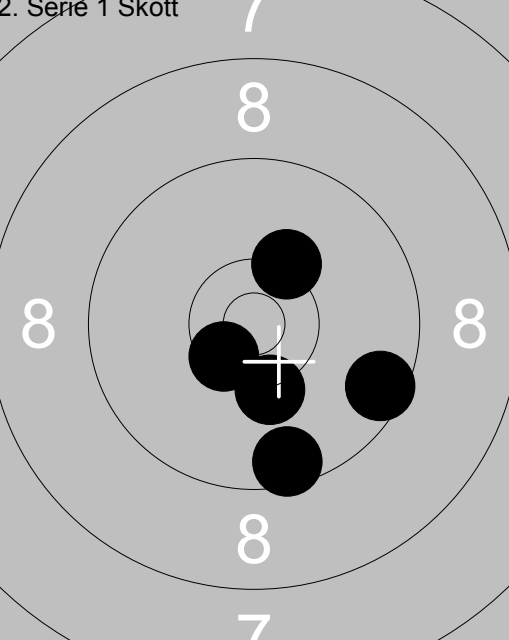
<p>2. Serie 1 Skott</p> 	<p>1: *10.5↙ 2: 9.5 → 3: 10.3↗ 4: 9.5 ↓ 5: 10.3↓</p> <p>Serie 48.0 Total 327.0</p>	
--	---	--

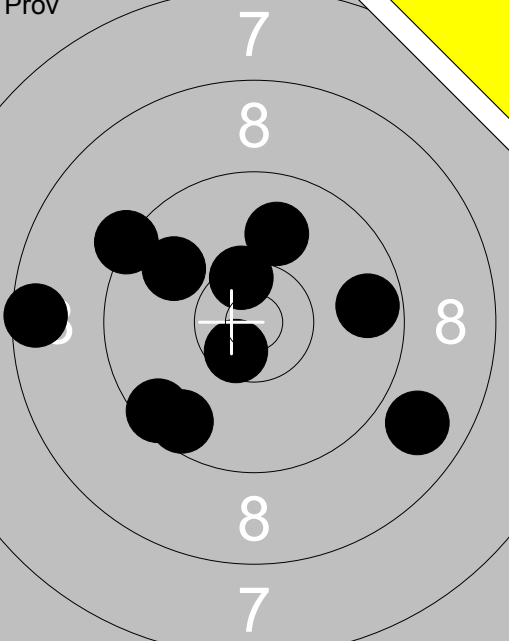
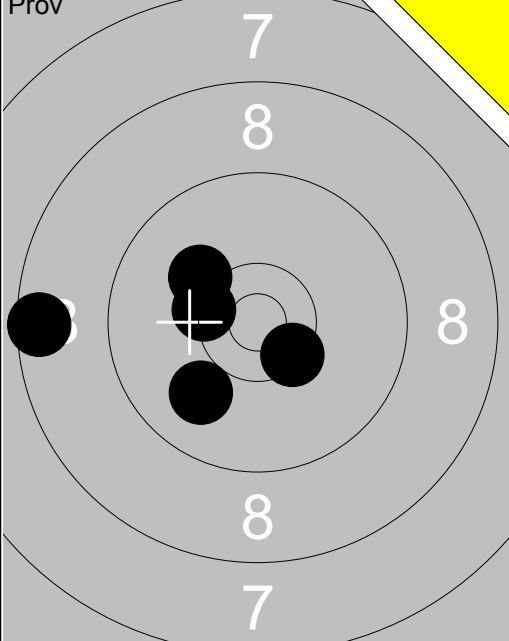
Prov 	1: 9.7 → 2: 9.6 ↘ 3: *10.6 ↘ 4: 8.9 → 5: *10.4 ↗ 6: 9.5 ↘ 7: 9.3 ↖ 8: 10.0 ↗ 9: 8.6 ← 10: 9.9 ↖	Prov 	11: *10.4 ↘ 12: 10.0 ↘ 13: 8.5 ← 14: *10.3 ↖ 15: 10.1 ↖
Serie 91.0		Serie 48.0	
Total 189.0		Total 189.0	

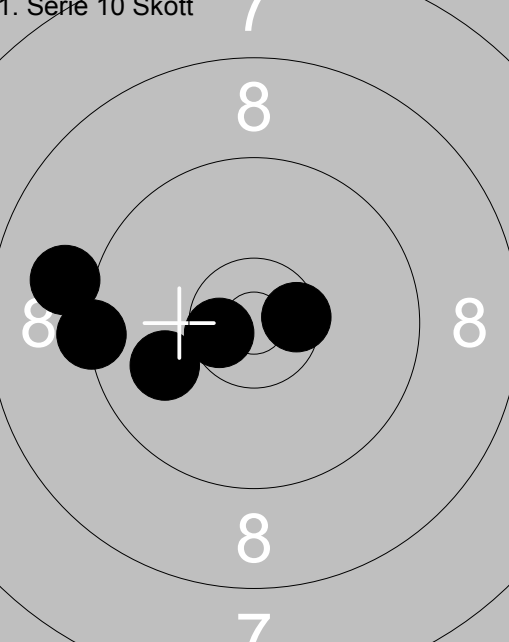
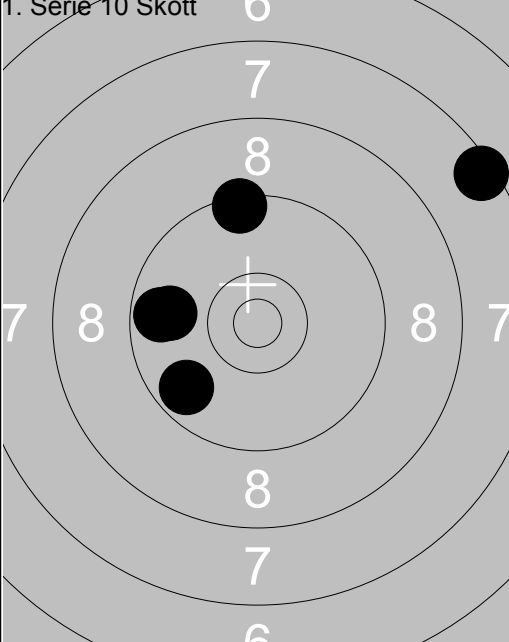
1. Serie 10 Skott 	1: *10.6 ↖ 2: 9.3 ← 3: 9.0 ← 4: *10.5 → 5: 10.0 ↖	1. Serie 10 Skott 	6: 9.7 ← 7: 9.8 ← 8: 9.7 ↘ 9: 7.5 ↗ 10: 9.4 ↗
Serie 48.0		Serie 43.0	
Total 237.0		Total 280.0	

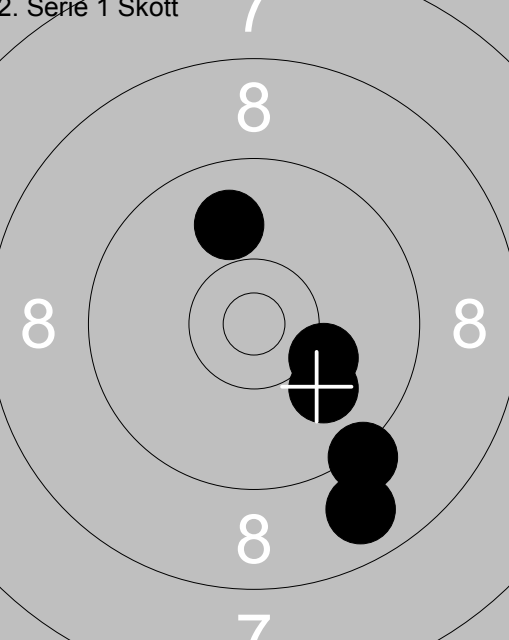
2. Serie 1 Skott 	1: 10.0 ↘ 2: 8.8 ↘ 3: 9.9 ↗ 4: 10.2 → 5: 9.2 ↘		
Serie 46.0			
Total 326.0			

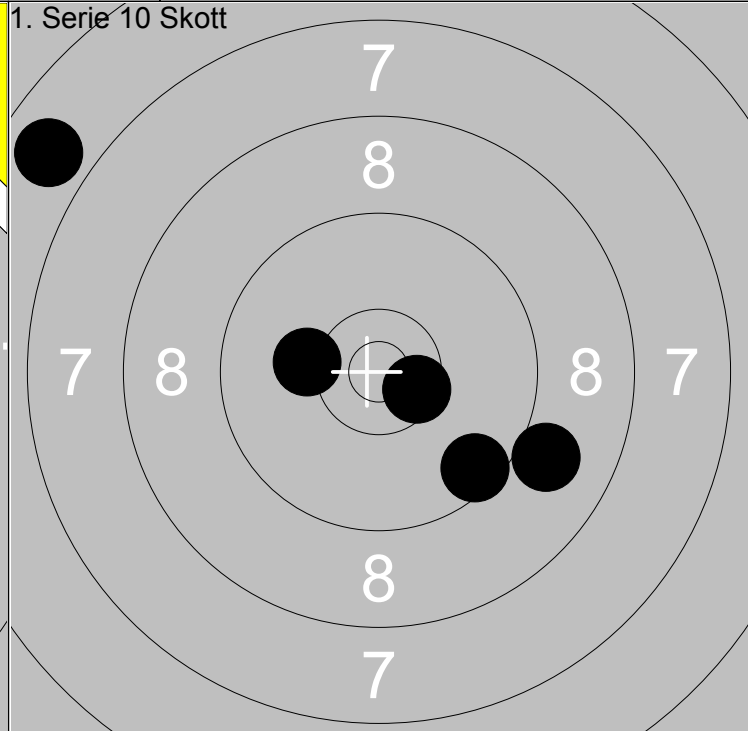
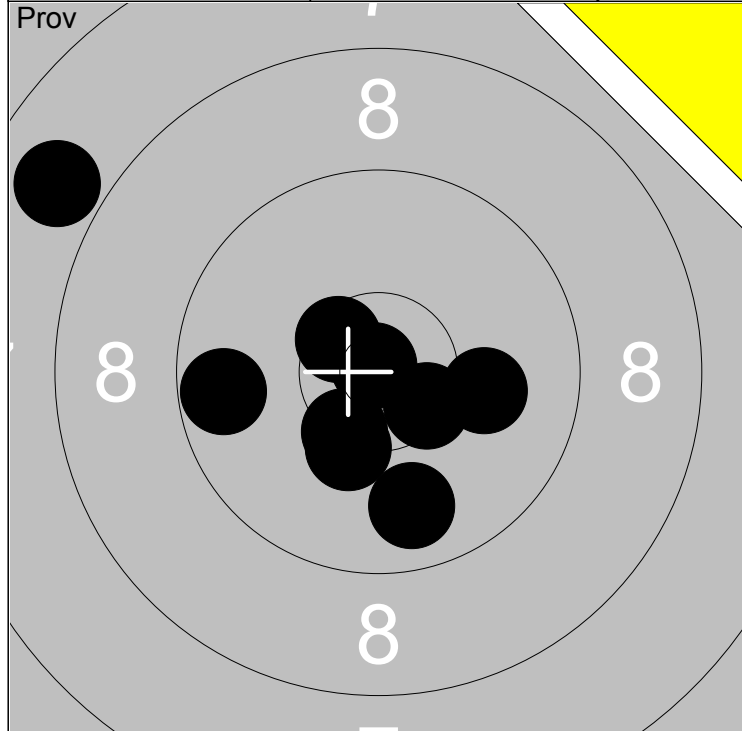

1: 9.7 ←	6: 7.9 ↖	Serie	85.0
2: 10.3 ↓	7: *10.4 ↓		
3: *10.5 ↘	8: *10.5 ↘	Total	185.0
4: *10.9 ↗	9: 9.8 ↓		
5: 10.1 →			

1: *10.5 ↘	Serie	44.0
2: 9.5 ↓		
3: 9.0 ↘	Total	229.0
4: 6.8 ↗		
5: 10.2 ←		

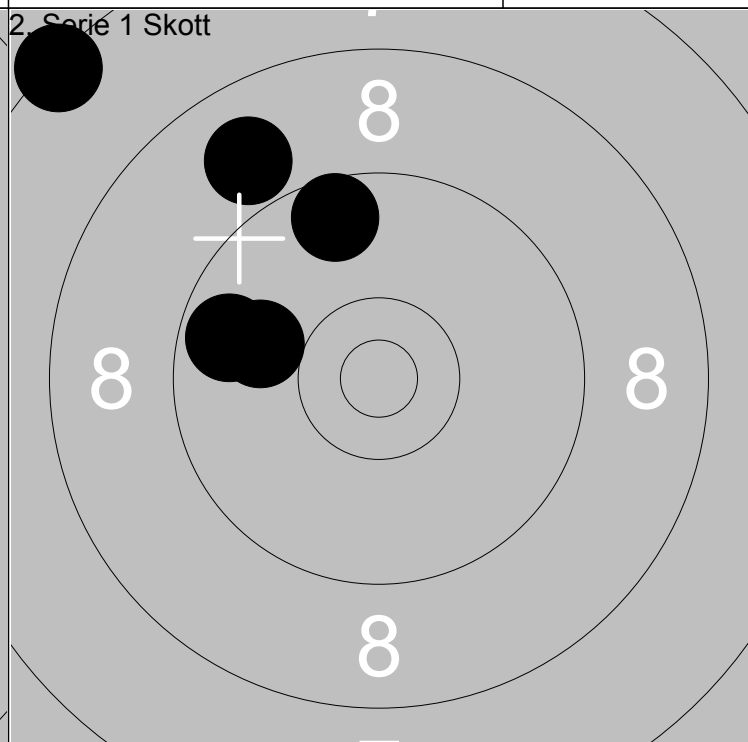
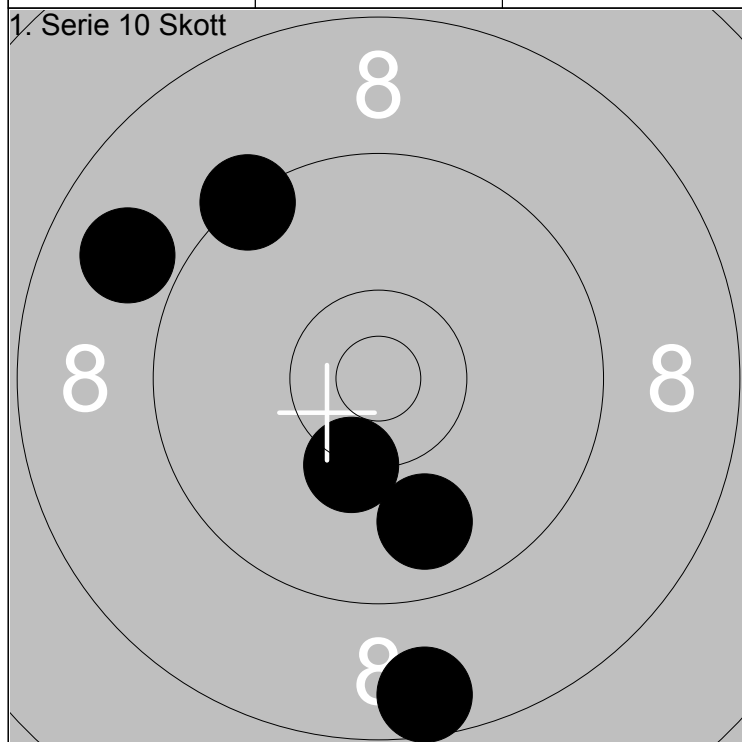

6: 9.3 ↗	Serie	44.0
7: 8.6 ↓		
8: *10.3 ↓	Total	273.0
9: 8.9 ↖		
10: 9.8 ↓		

1: 10.0 ←	Serie	43.0
2: 9.7 ←		
3: 9.6 ↗	Total	316.0
4: 7.4 ↗		
5: 8.9 ↗		

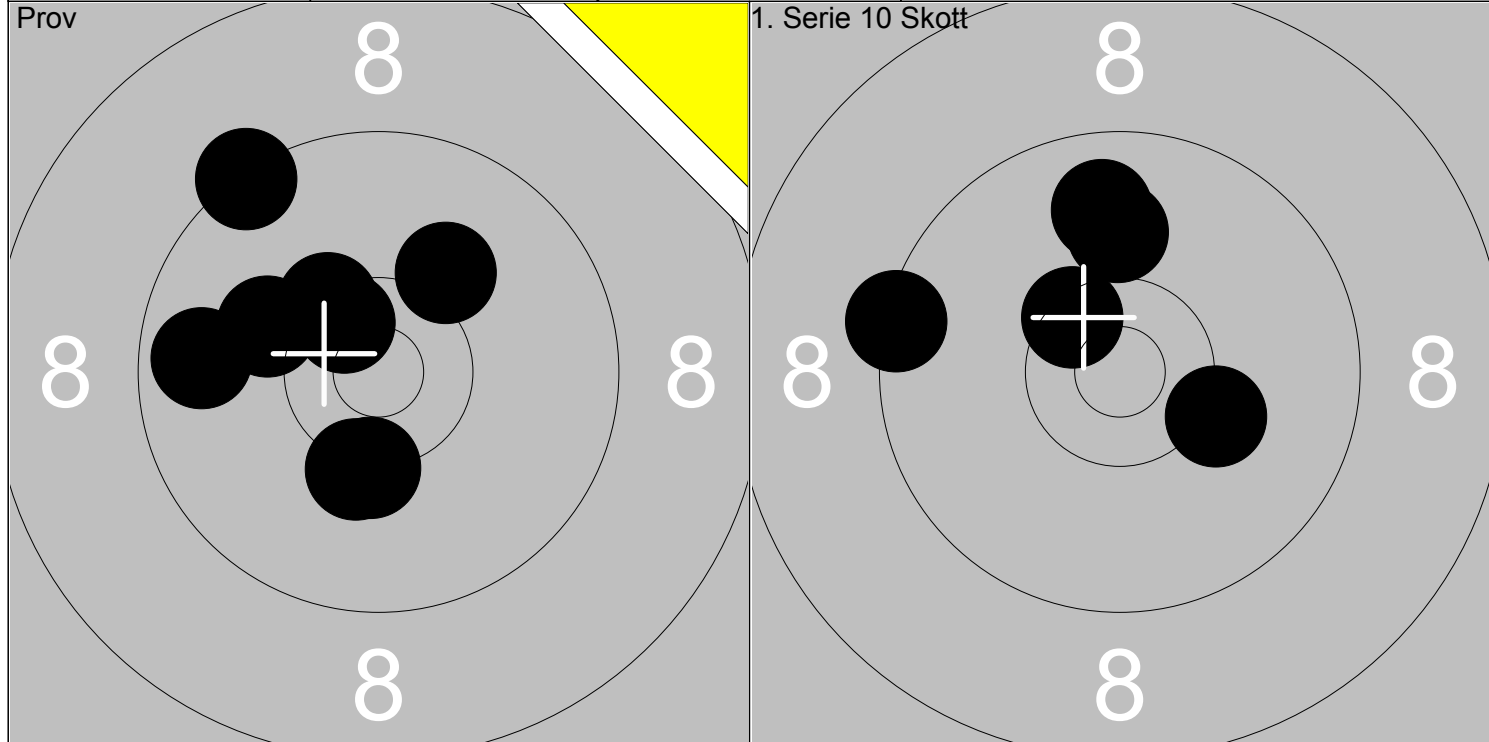

1: *10.5 ↗	6: 10.3 ↓			1: 10.2 ➤			
2: 10.3 ↓	7: 10.1 ↗	Serie	78.0	2: 9.4 ←	Serie	48.0	
3: 10.1 ←	8: *10.4 ↗	Total	195.0	3: *10.5 ↗	Total	243.0	
4: 9.3 ↗				4: 9.8 ↑			
5: 9.7 ←				5: 10.0 ↑			

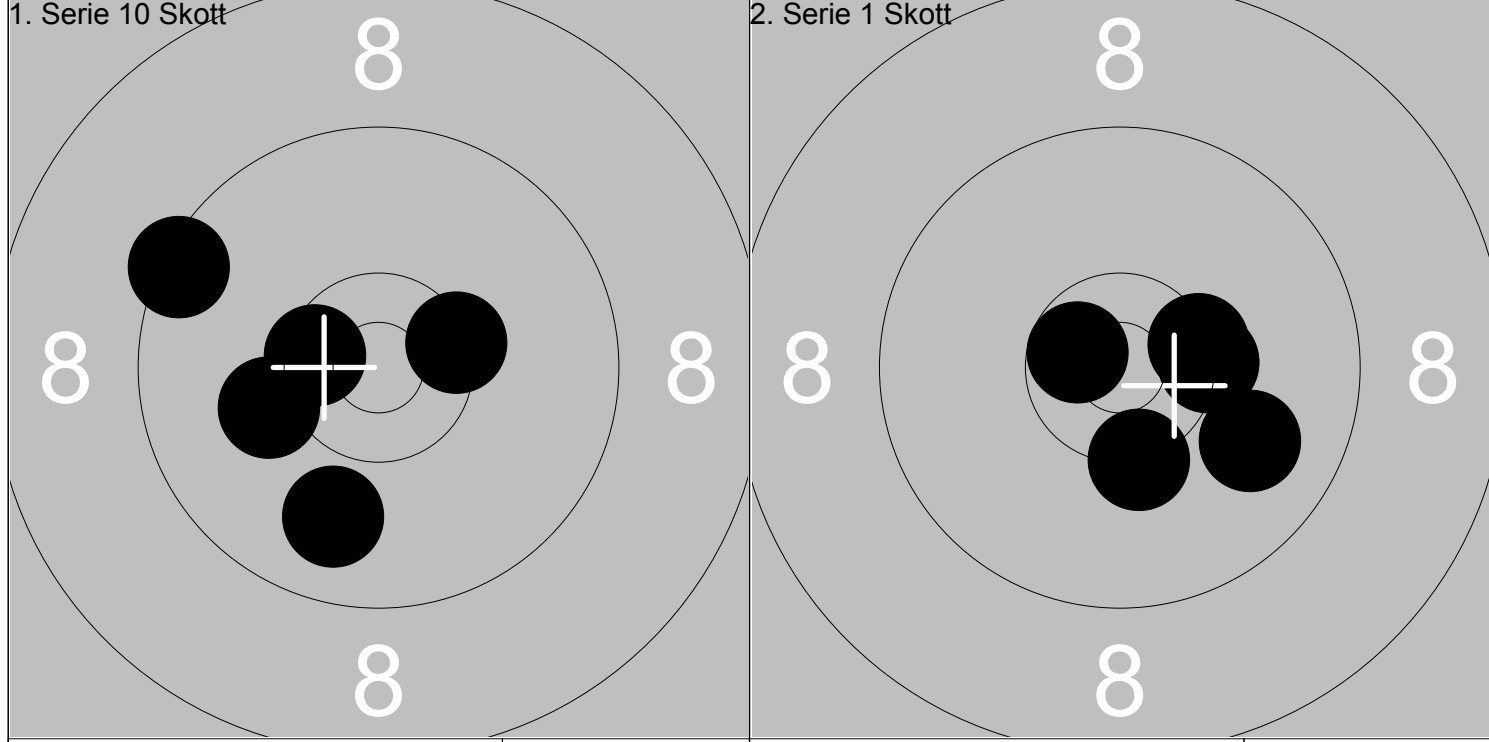

6: 10.1 ←				1: *10.3 ➤			
7: 9.4 ←		Serie	48.0	2: *10.3 ↓	Serie	49.0	
8: 9.9 ↓		Total	291.0	3: *10.4 ➤	Total	340.0	
9: *10.4 ➤				4: 9.9 ➤			
10: *10.5 ↗				5: *10.6 ↗			

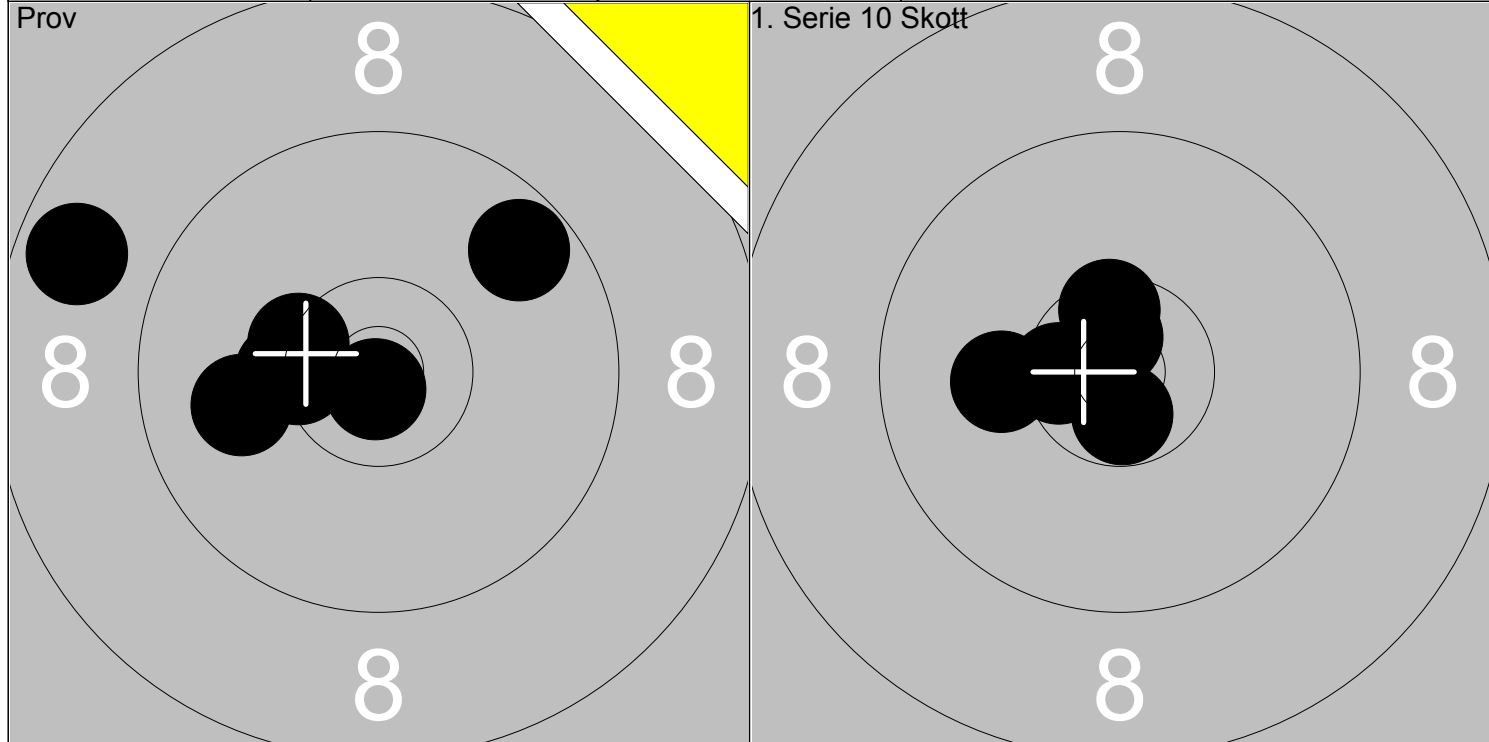

1: 9.7 ↗	6: *10.4↙			1: *10.5↑				
2: *10.8↓	7: *10.3↙	Serie	67.0	2: *10.5↙				Serie
3: 10.0 ←				3: *10.7↑				50.0
4: 8.7 ↙		Total	194.0	4: 10.1 ←				Total
5: *10.4↙				5: *10.7↓				244.0

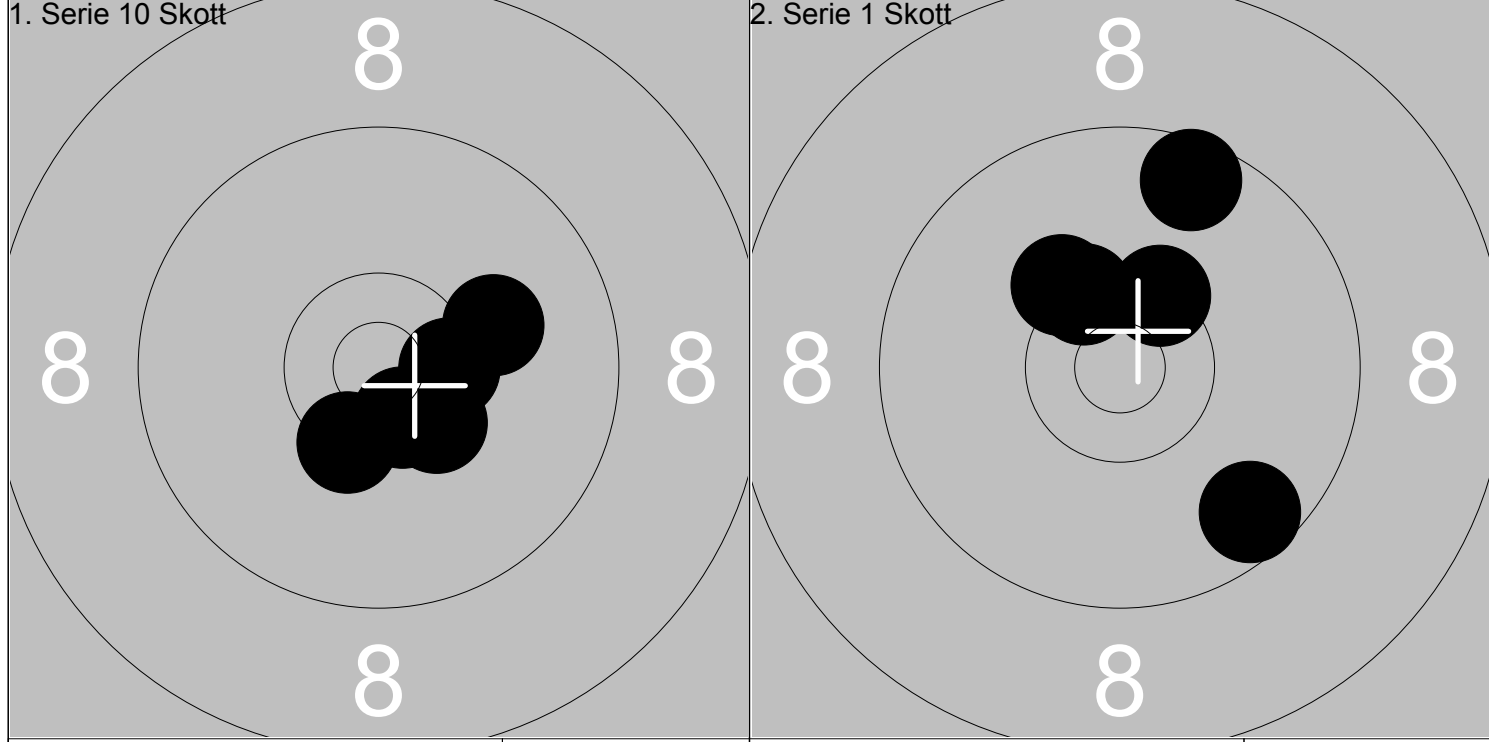

6: *10.6↓				1: *10.4↗				
7: *10.5→		Serie	50.0	2: 9.6 ↗				Serie
8: *10.4↓				3: 10.3 ↖				48.0
9: 10.1 →		Total	294.0	4: *10.4↗				Total
10: *10.4↓				5: 9.6 ↘				342.0

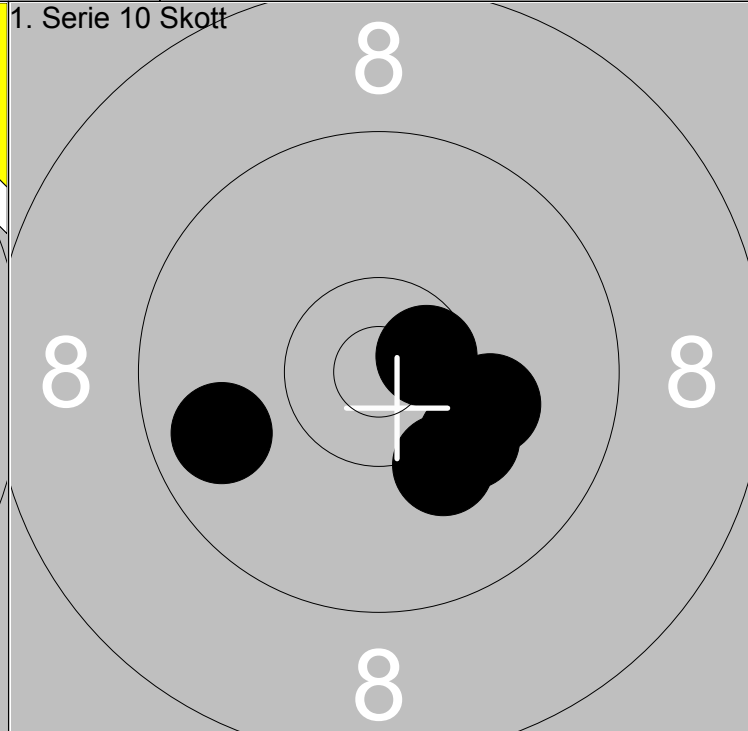
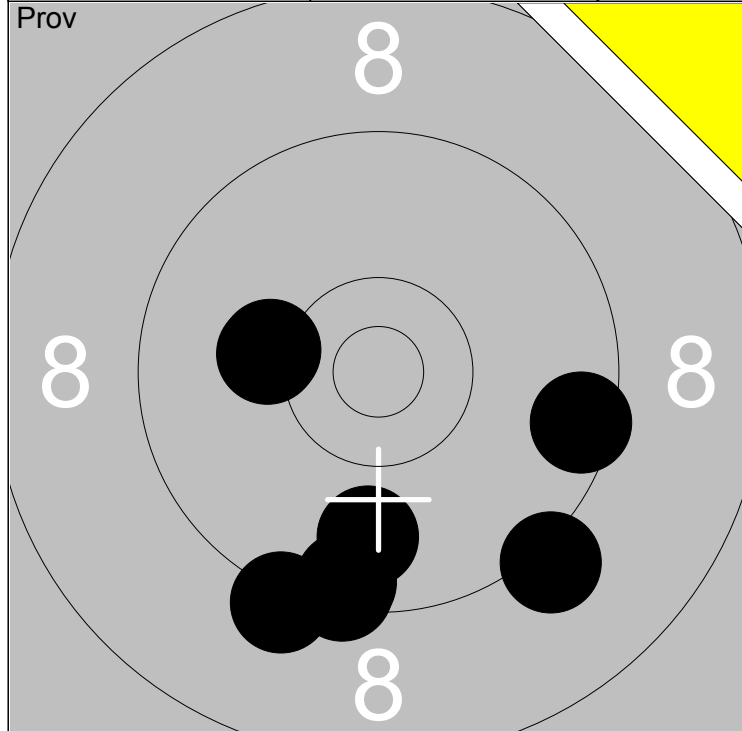

1: 9.4 ↓	6: 9.8 ↓	Serie	74.0
2: 9.5 →	7: 10.2 ←		
3: 9.2 ↓	8: 10.2 ←	Total	192.0
4: 9.5 ↓			
5: 9.2 ↓			

1: 10.2 ↓	Serie	49.0
2: 9.8 ←		
3: 10.2 →	Total	241.0
4: *10.6 →		
5: 10.2 ↓		

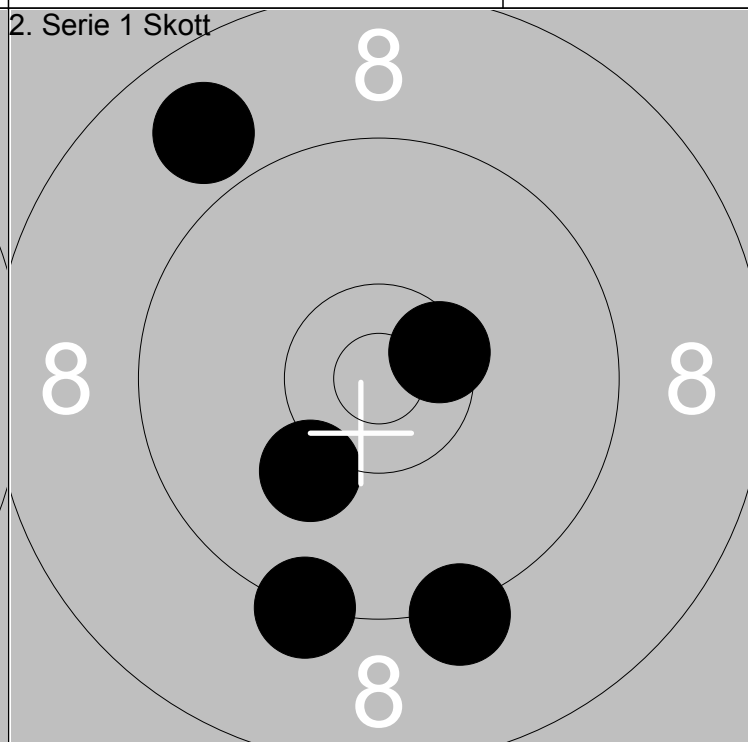
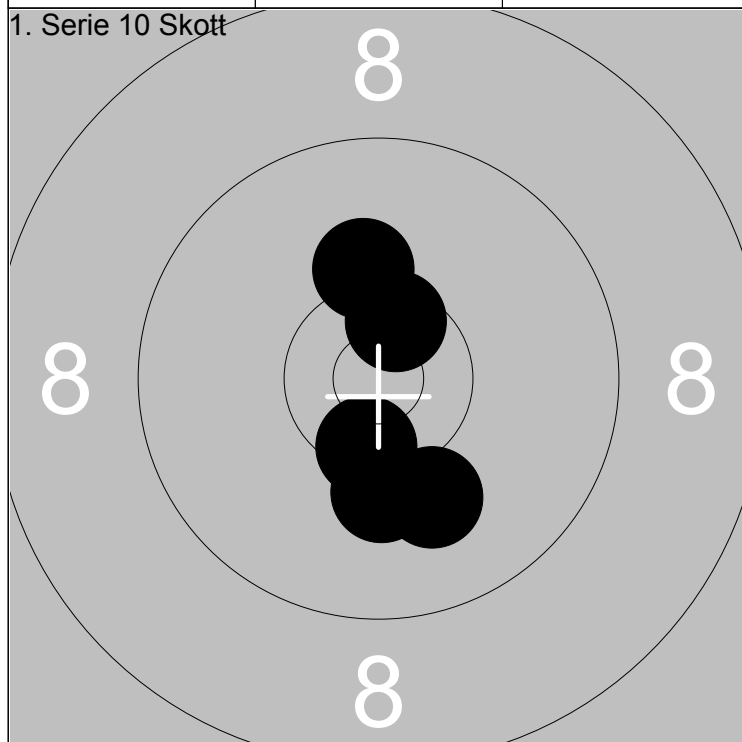

6: *10.5 ↓	Serie	50.0
7: 10.1 ↓		
8: 10.2 ↓	Total	291.0
9: 10.2 ↑		
10: *10.5 ↑		

1: 9.2 ↓	Serie	46.0
2: 8.9 ↗		
3: *10.5 →	Total	337.0
4: 9.3 ↓		
5: 10.2 ↓		

<p>Prov</p>	<p>1: 9.2 → 2: 9.9 → 3: 9.5 → 4: 9.5 ↓ 5: 9.3 → 6: *10.7↑ 7: 8.4 ← 8: 10.0↙ 9: 10.0↙ 10: 9.1 ↓</p>	<p>Prov</p>	<p>11: 9.9 ← 12: *10.4↓ 13: 9.5 ↙</p>
Serie 92.0		Serie 28.0	
Total 190.0		Total 190.0	

<p>1. Serie 10 Skott</p>	<p>1: 8.6 ↓ 2: 10.2↙ 3: 10.0 ↓ 4: 9.0 ← 5: *10.9↙</p>	<p>1. Serie 10 Skott</p>	<p>6: 9.4 ↓ 7: 9.5 ↓ 8: 9.4 → 9: 10.1↙ 10: 9.0 ↓</p>
Serie 47.0		Serie 46.0	
Total 237.0		Total 283.0	

<p>2. Serie 1 Skott</p>	<p>1: 9.7 ↑ 2: 8.5 ↘ 3: 10.1 ↓ 4: 9.9 ↘ 5: 10.0↙</p>		
Serie 46.0			
Total 329.0			

<p>Prov</p>	<p>1: *10.7 ↖</p> <p>2: 8.2 →</p> <p>3: 9.3 ↗</p> <p>4: 8.8 ↗</p> <p>5: 9.3 →</p> <p>6: 9.0 ↑</p> <p>7: *10.4 ↖</p> <p>8: 8.4 ↖</p> <p>9: 9.2 ↑</p> <p>10: 9.4 ↘</p>	<p>Prov</p>	<p>11: 9.8 ↗</p> <p>12: *10.4 ↖</p> <p>13: 10.0 ↖</p>
Serie 89.0		Serie 29.0	
Total 182.0		Total 182.0	

<p>1. Serie 10 Skott</p>	<p>1: 9.5 ↘</p> <p>2: 8.4 ←</p> <p>3: 10.1 ↖</p> <p>4: *10.6 ↖</p> <p>5: 9.8 ←</p>	<p>1. Serie 10 Skott</p>	<p>6: 9.2 ↑</p> <p>7: 7.9 ↖</p> <p>8: 10.0 ←</p> <p>9: 9.5 ↖</p> <p>10: 10.1 ↗</p>
Serie 46.0		Serie 45.0	
Total 228.0		Total 273.0	

<p>2. Serie 1 Skott</p>	<p>1: 9.8 ←</p> <p>2: 9.8 ↑</p> <p>3: 9.9 ↗</p> <p>4: 9.6 ↘</p> <p>5: 9.1 ↗</p>		
Serie 45.0			
Total 318.0			

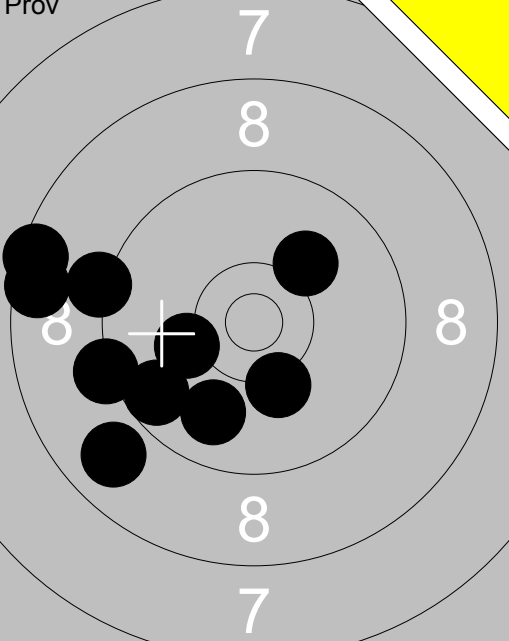
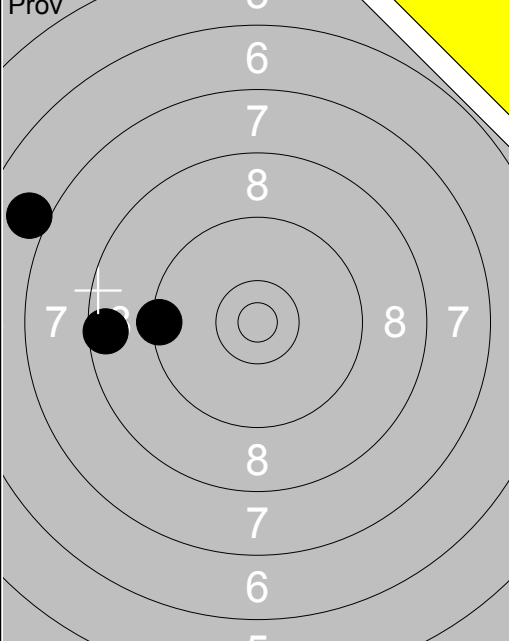
<p>Prov</p> 	<p>1: 10.2 ← 2: 8.5 ← 3: 8.9 ↙ 4: 9.6 ← 5: 9.9 ↘ 6: 8.6 ← 7: 9.2 ← 8: 9.2 ← 9: 10.1 ↗ 10: 10.2 ↓</p>	<p>Prov</p> 	<p>11: 9.4 ← 12: 8.6 ← 13: 7.0 ↖</p>
Serie 90.0		Serie 24.0	
Total 176.0		Total 176.0	

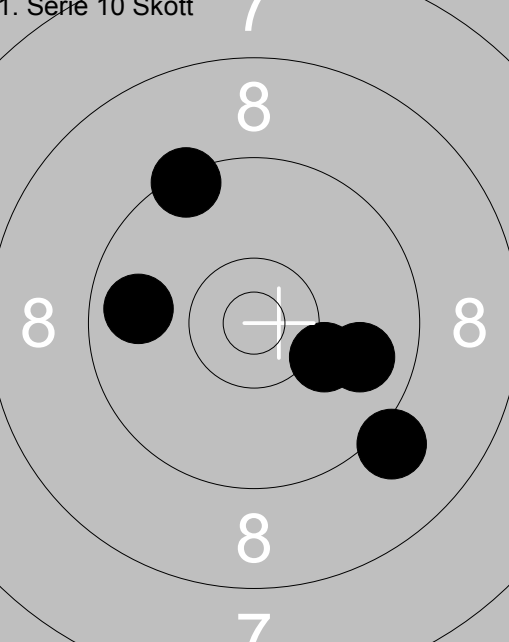
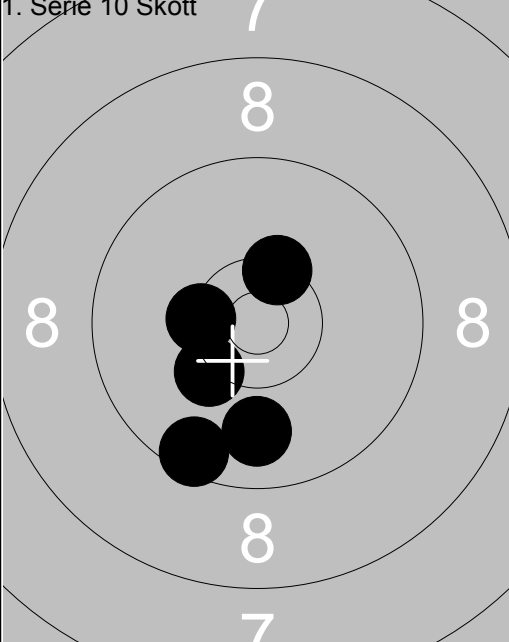
<p>1. Serie 10 Skott</p> 	<p>1: 9.8 ← 2: 9.1 ↘ 3: 10.2 → 4: 9.4 ↗ 5: 9.8 →</p>	<p>1. Serie 10 Skott</p> 	<p>6: *10.4 ↗ 7: 10.3 ↘ 8: 9.5 ↘ 9: *10.4 ← 10: 9.9 ↓</p>
Serie 46.0		Serie 48.0	
Total 222.0		Total 270.0	

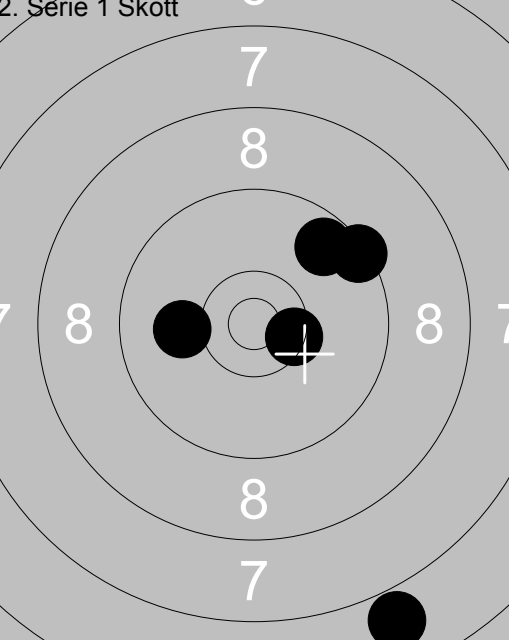
<p>2. Serie 1 Skott</p> 	<p>1: 6.9 ↓ 2: 9.4 ↗ 3: 9.7 ↗ 4: 10.1 ← 5: *10.4 →</p>		
Serie 44.0			
Total 314.0			

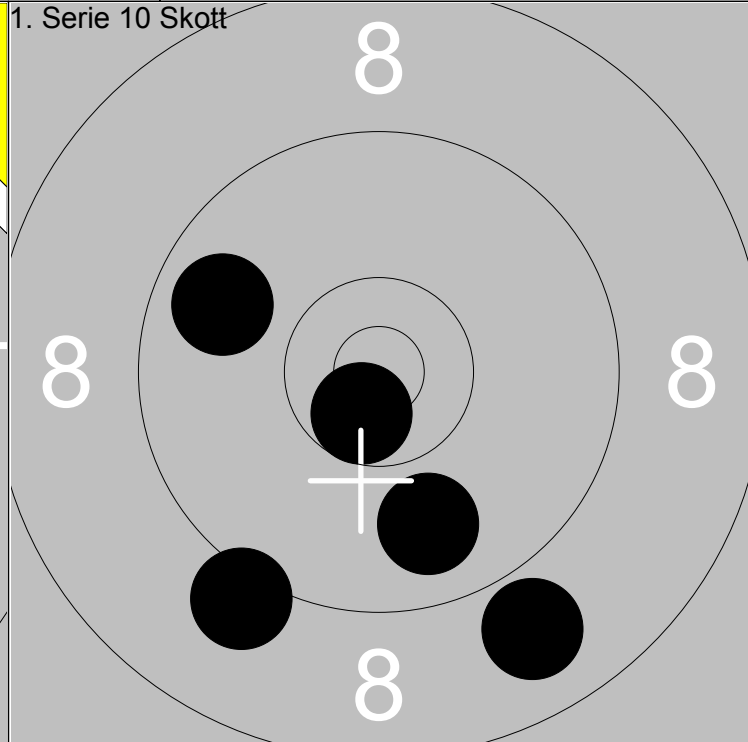
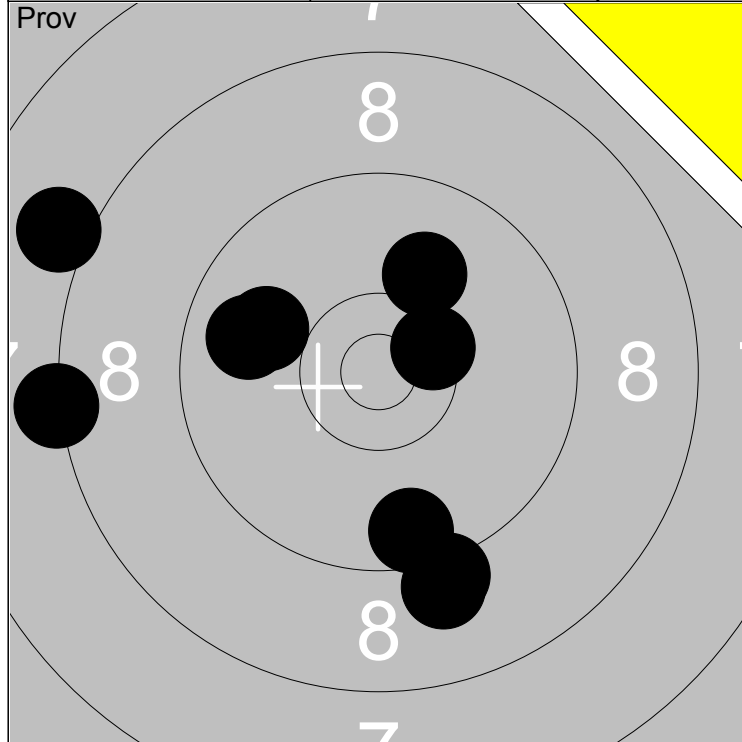

1: 10.1 ↗	6: 10.0 ←	Serie	82.0
2: 9.6 ↓	7: 9.2 ↓		
3: 8.3 ←	8: 8.1 ←	Total	194.0
4: 9.1 ↓	9: 9.8 ←		
5: *10.5 →			

1: 8.9 ↓	Serie	45.0
2: 9.8 ↖		
3: 9.1 ↓	Total	239.0
4: 9.9 ↓		
5: *10.6 ↓		

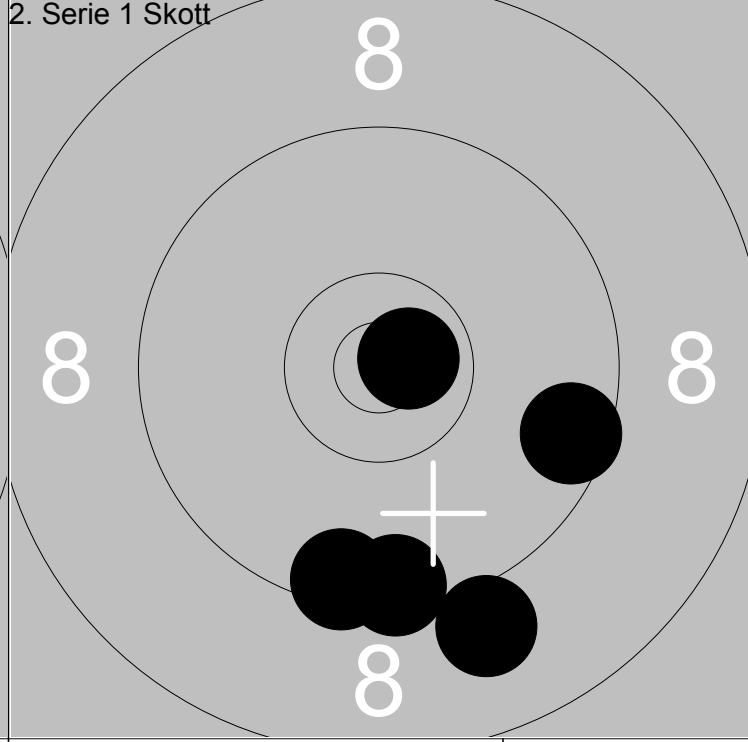
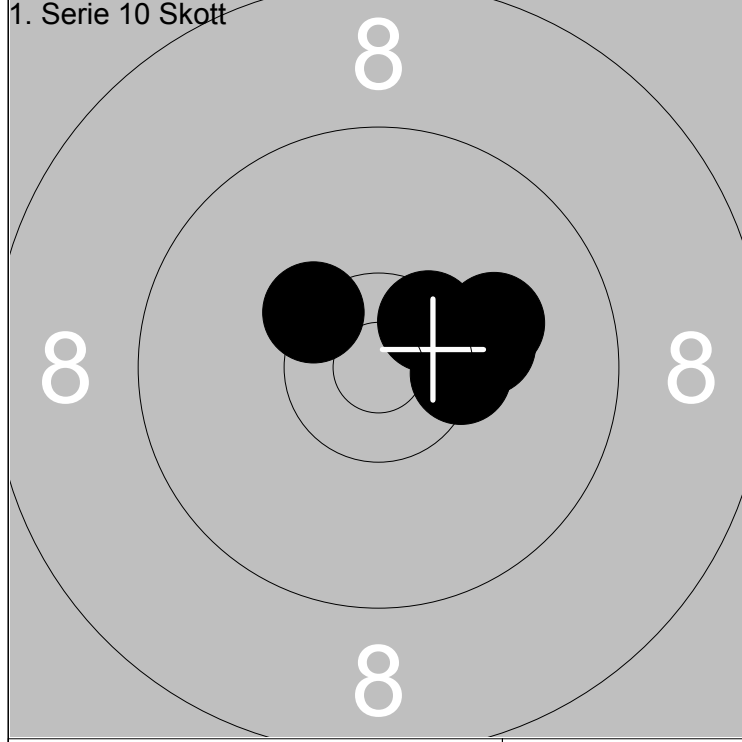

6: 10.2 →	Serie	50.0
7: 10.1 →		
8: *10.4 ↖	Total	289.0
9: *10.5 ↗		
10: *10.4 →		

1: 9.0 ↓	Serie	46.0
2: 9.6 →		
3: *10.7 →	Total	335.0
4: 9.5 ↓		
5: 9.5 ↓		

<p>Prov</p>	<p>1: 9.1 ↖ 2: 9.7 ↑ 3: 9.0 ↑ 4: 9.2 ↖ 5: 9.8 ↑ 6: 7.8 ↖ 7: 10.0 ← 8: 9.1 ↑ 9: 10.0 ↓ 10: 8.3 ↖</p> <p>Serie 89.0 Total 177.0</p>	<p>Prov</p>	<p>11: 10.1 ↖ 12: 10.1 → 13: 10.2 ↓ 14: 9.8 ↖ 15: 9.1 ↑</p> <p>Serie 48.0 Total 177.0</p>
-------------	---	-------------	--

<p>1. Serie 10 Skott</p>	<p>1: 9.1 ↙ 2: 9.9 ← 3: *10.5 → 4: 9.1 ↓ 5: 9.3 ↖</p> <p>Serie 46.0 Total 223.0</p>	<p>1. Serie 10 Skott</p>	<p>6: 9.4 ↖ 7: 10.1 ↓ 8: 8.9 ↓ 9: 9.5 ↓ 10: *10.5 ↗</p> <p>Serie 46.0 Total 269.0</p>
--------------------------	--	--------------------------	--

<p>2. Serie 1 Skott</p>	<p>1: 9.0 ↙ 2: 9.7 ↓ 3: 10.1 → 4: 9.6 ← 5: *10.6 ↖</p> <p>Serie 47.0 Total 316.0</p>		
-------------------------	---	--	--

<p>Prov</p>	<p>1: 8.4 →</p> <p>2: 8.6 →</p> <p>3: 10.0 ←</p> <p>4: 9.5 ←</p> <p>5: 8.4 ↑</p> <p>6: 8.9 ↑</p> <p>7: 9.9 ←</p> <p>8: 9.7 ↗</p> <p>9: 9.9 ←</p> <p>10: 9.4 ↓</p>	<p>Prov</p>	<p>11: 9.0 ↘</p> <p>12: 9.7 ↙</p> <p>13: 9.7 ↗</p>
Serie 87.0		Serie 27.0	
Total 177.0		Total 177.0	

<p>1. Serie 10 Skott</p>	<p>1: 9.6 ↙</p> <p>2: 8.6 ↙</p> <p>3: 9.9 ↗</p> <p>4: 10.2 ↘</p> <p>5: 9.1 →</p>	<p>1. Serie 10 Skott</p>	<p>6: 9.7 ↘</p> <p>7: 8.9 →</p> <p>8: 7.4 →</p> <p>9: 9.7 ↙</p> <p>10: *10.3 ↗</p>
Serie 45.0		Serie 43.0	
Total 222.0		Total 265.0	

<p>2. Serie 1 Skott</p>	<p>1: 9.2 ↙</p> <p>2: 8.6 ←</p> <p>3: 8.8 ↙</p> <p>4: 10.1 ←</p> <p>5: 9.6 ↑</p>		
Serie 44.0			
Total 309.0			

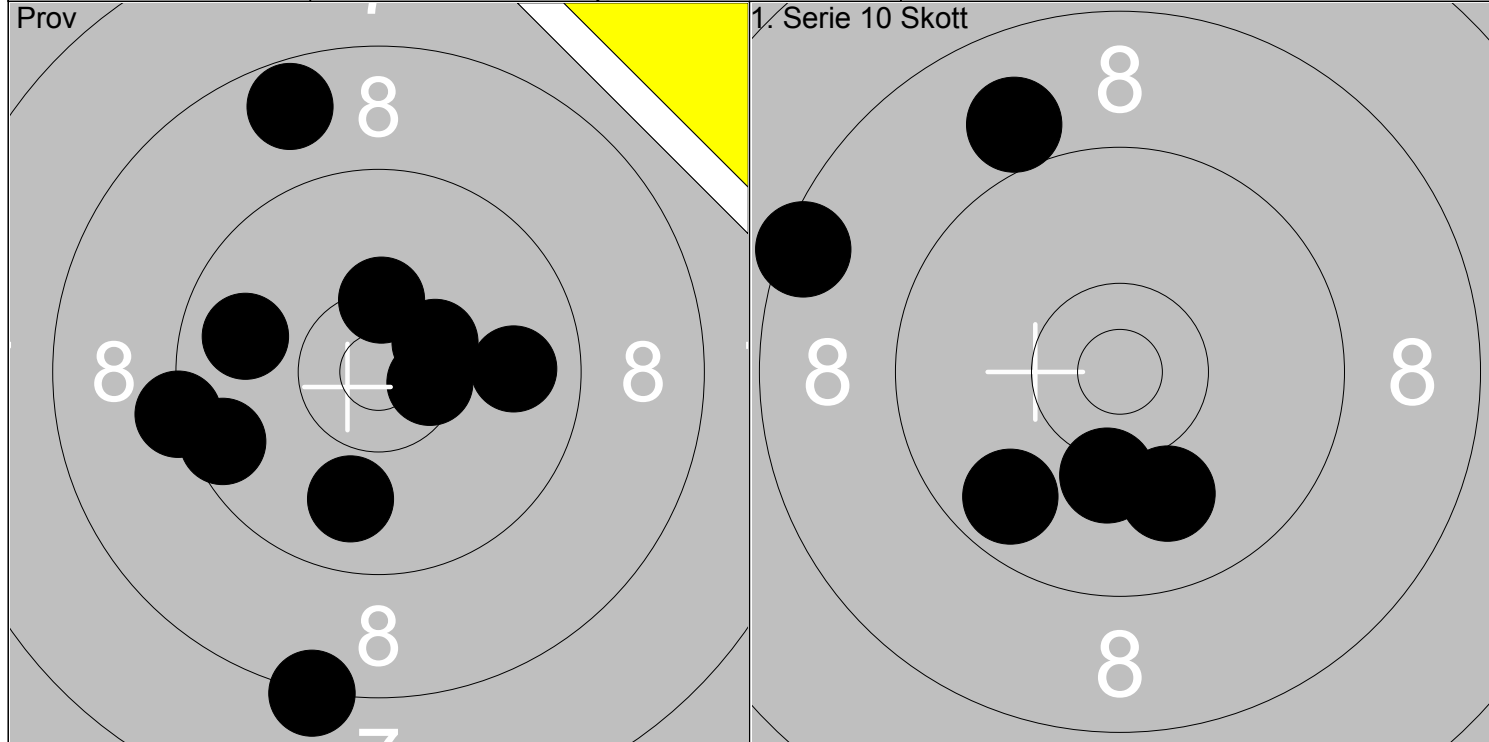

1: *10.5 →	6: 9.8 ←	Serie	91.0	1: 8.5 ←	Serie	46.0
2: 9.3 ←	7: *10.4 →			2: 10.0 ↓		
3: 8.3 ↓	8: 9.8 →	Total	177.0	3: 9.7 ↙	Total	223.0
4: *10.4 ↑	9: 8.7 ↗			4: 10.2 ↓		
5: 9.6 ←	10: 9.9 ↓			5: 9.0 ↗		

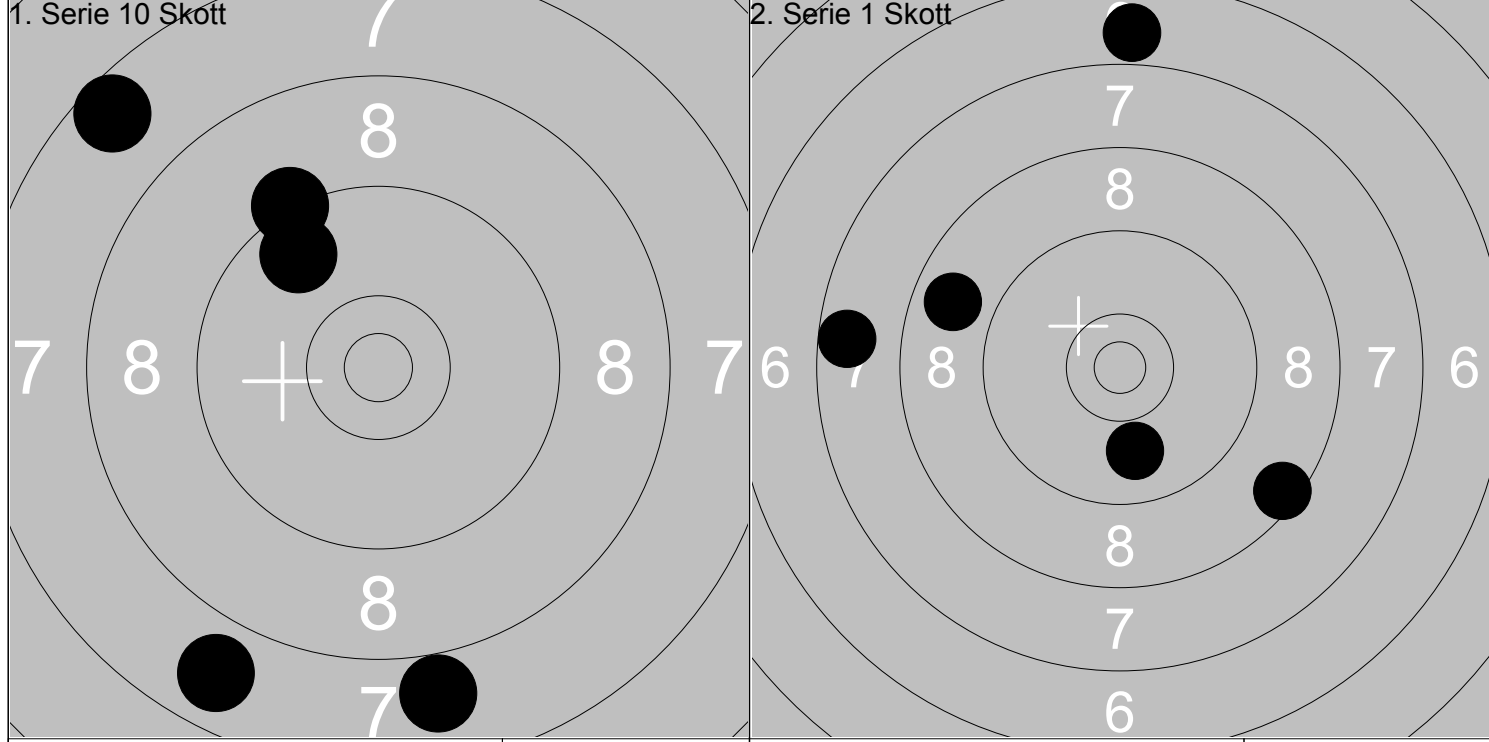

6: 9.7 ↗	Serie	39.0	1: 8.5 ↘	Serie	38.0
7: 7.6 ↗			2: 6.9 ↑		
8: 7.8 ↓	Total	262.0	3: 8.8 ←	Total	300.0
9: 7.9 ↓			4: 9.9 ↓		
10: 9.3 ↗			5: 7.6 ←		

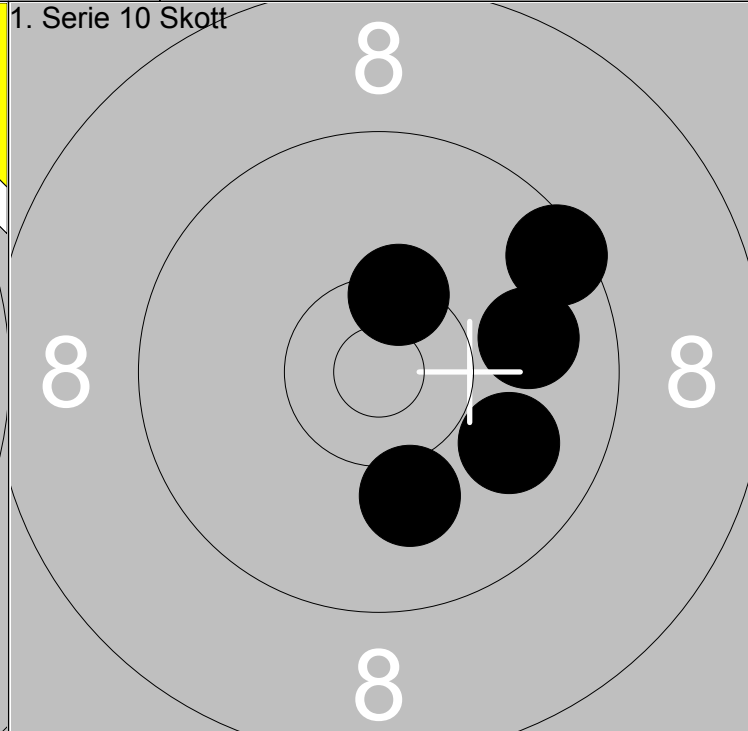
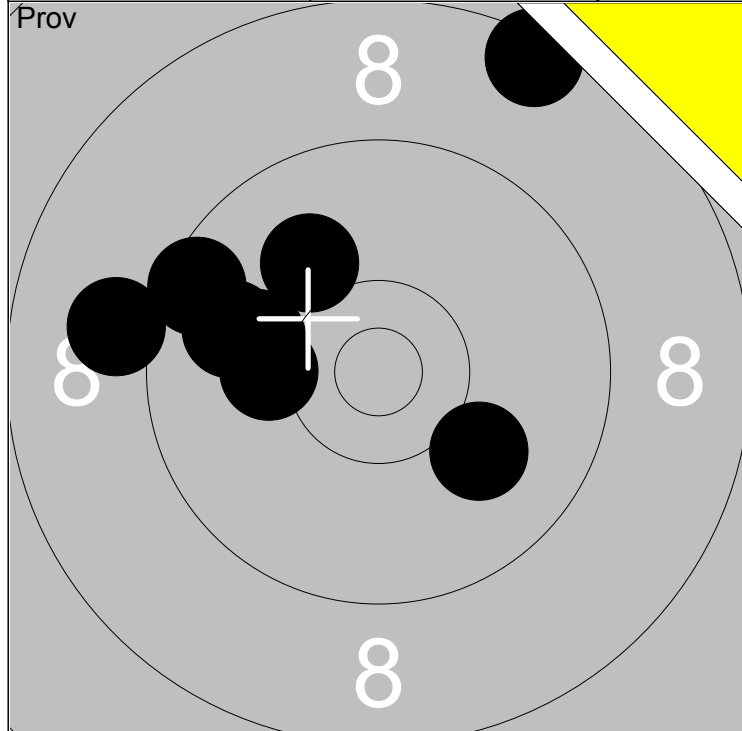

1: 10.2 ←	6: 9.9 ↙	Serie	75.0
2: 9.1 ←	7: 9.5 ↙		
3: 8.4 ↗	8: 10.0 ↘	Total	178.0
4: 10.0 ↗			
5: 10.0 ←			

1: 9.9 ↘	Serie	47.0
2: *10.4 ↗		
3: 10.1 ↘	Total	225.0
4: 9.9 →		
5: 9.5 ↗		

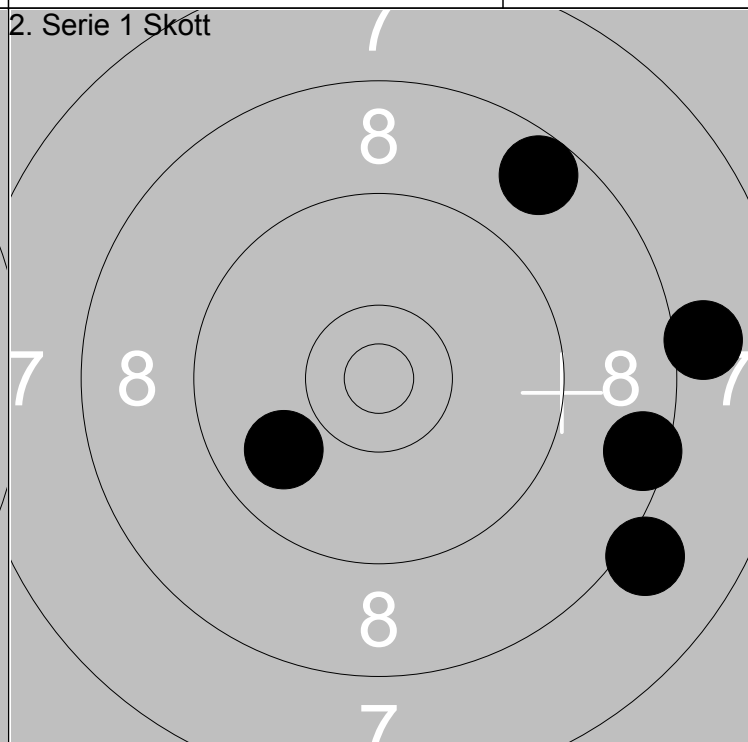
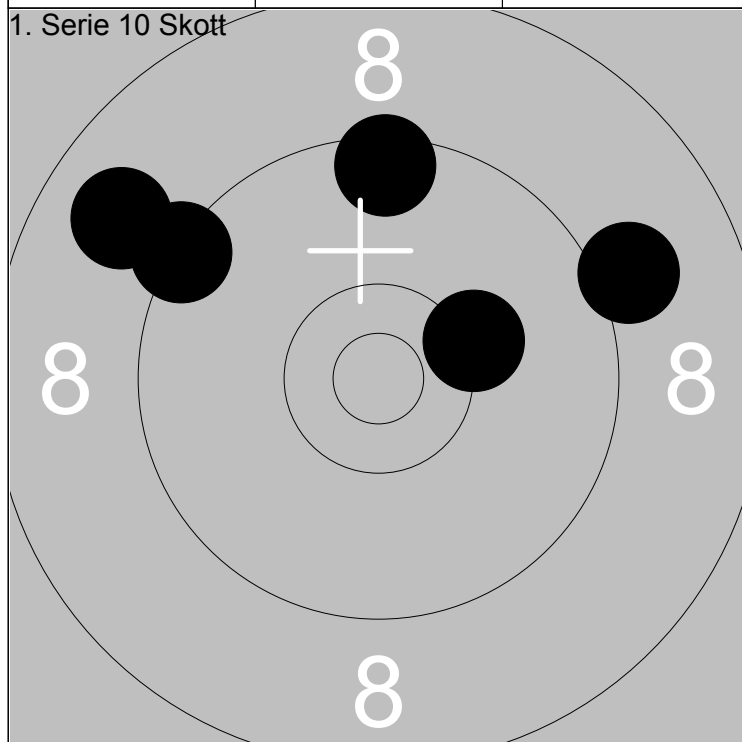

6: 8.9 ↙	Serie	45.0
7: 9.3 ↙		
8: 9.1 →	Total	270.0
9: 9.5 ↑		
10: 10.2 →		

1: 9.9 ↙	Serie	41.0
2: 8.7 ↗		
3: 8.0 →	Total	311.0
4: 8.5 →		
5: 8.1 ↘		

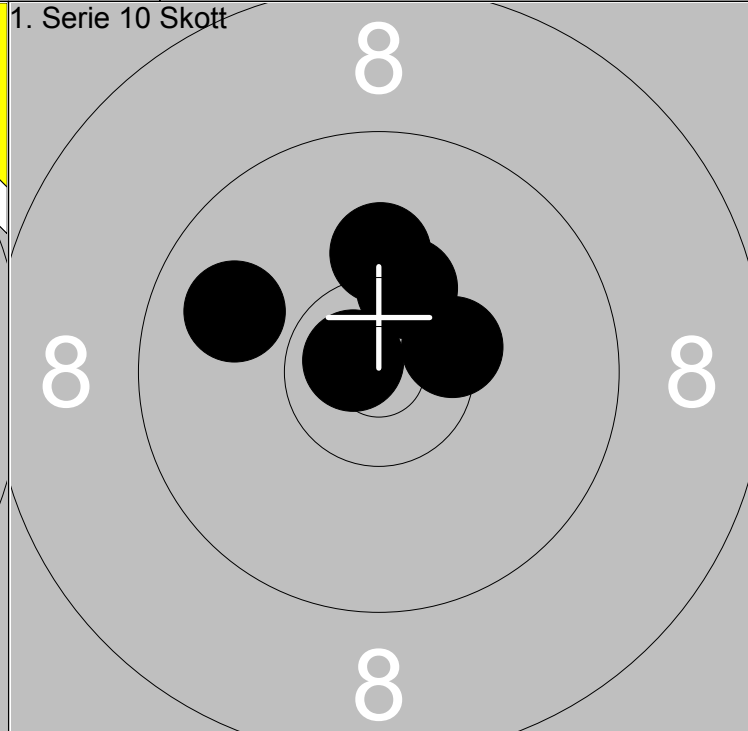
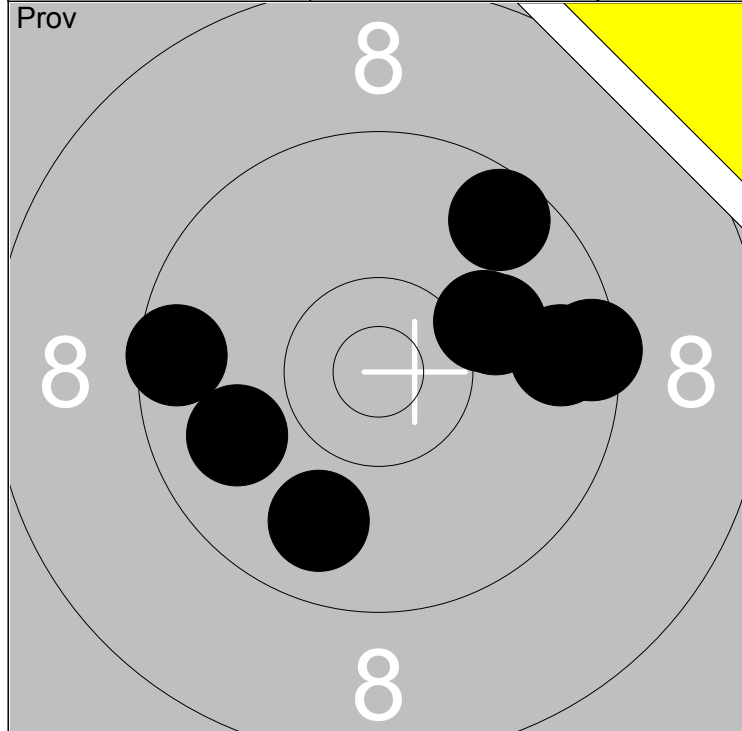

1: 9.6 ←	6: 9.5 →	Serie	74.0
2: 9.9 ↙	7: 10.1 →		
3: 9.8 ↓	8: 10.1 →	Total	177.0
4: 9.6 ↗			
5: 9.7 →			

1: 10.1 ↑	Serie	49.0
2: *10.8 ↙		
3: *10.3 ↑	Total	226.0
4: 9.9 ↙		
5: *10.4 →		

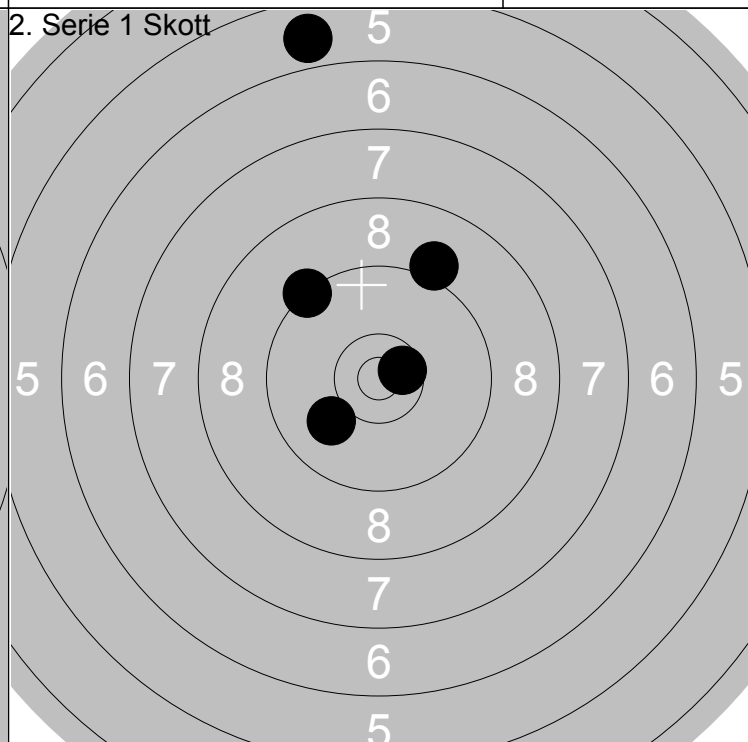
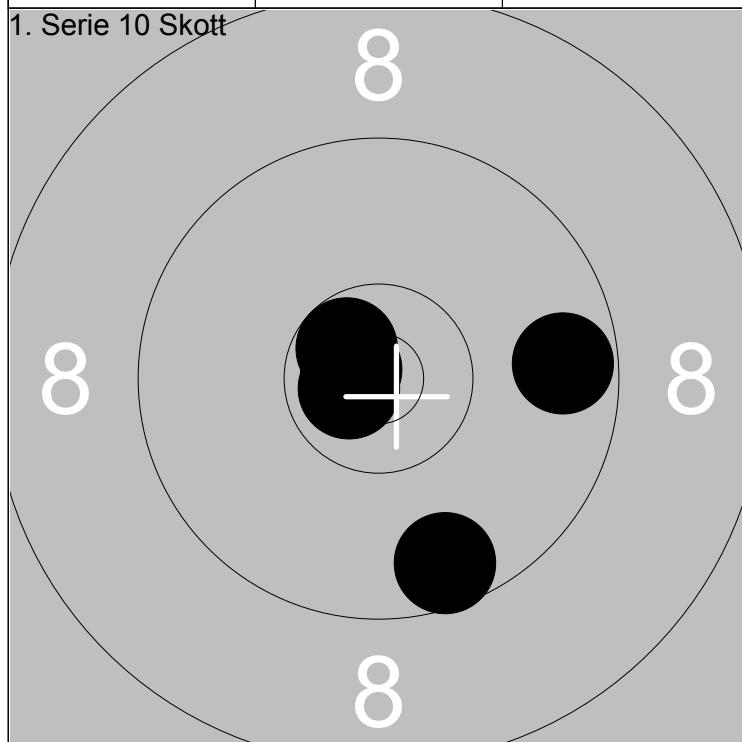

6: *10.8 ↙	Serie	48.0
7: *10.6 ↙		
8: *10.7 ↙	Total	274.0
9: 9.7 →		
10: 9.6 ↓		

1: 5.9 ↑	Serie	43.0
2: 9.1 ↗		
3: 9.3 ↙	Total	317.0
4: *10.6 →		
5: 10.0 ↙		

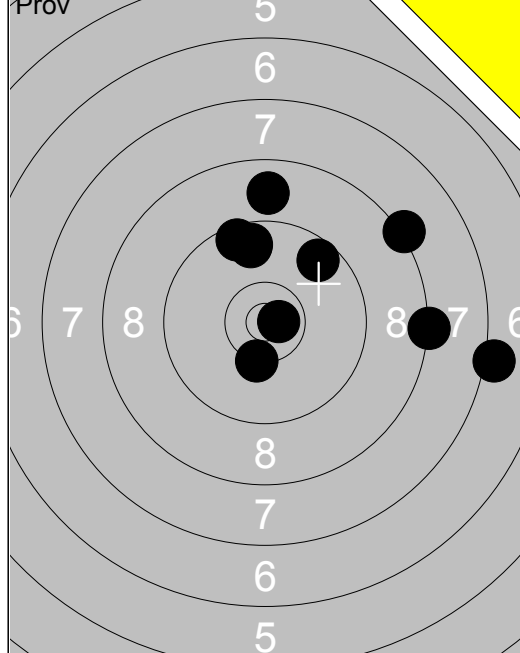

1:	8.2	↗
2:	8.3	→
3:	9.5	↑
4:	*10.3	↓
5:	9.6	↗
6:	9.7	↑
7:	7.2	→
8:	*10.7	→
9:	8.8	↑
10:	9.7	↑
Serie		87.0
Total		171.0

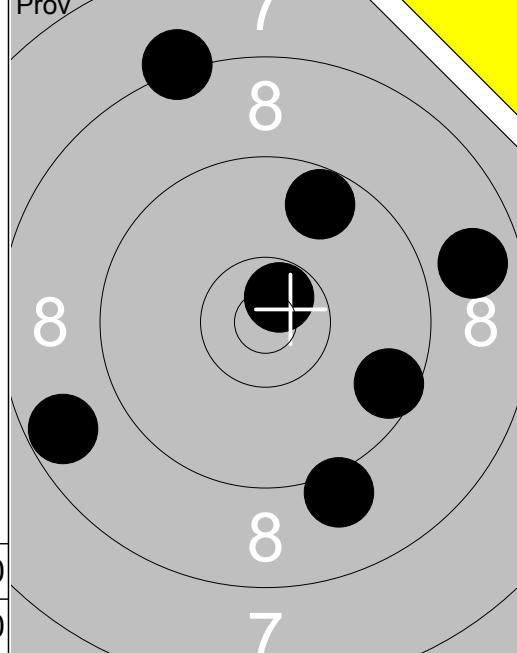

11:	9.7	↗
12:	8.7	↙
13:	8.2	↑
14:	9.6	↘
15:	9.1	↓
16:	8.8	→
17:	*10.7	↗
Serie		61.0
Total		171.0

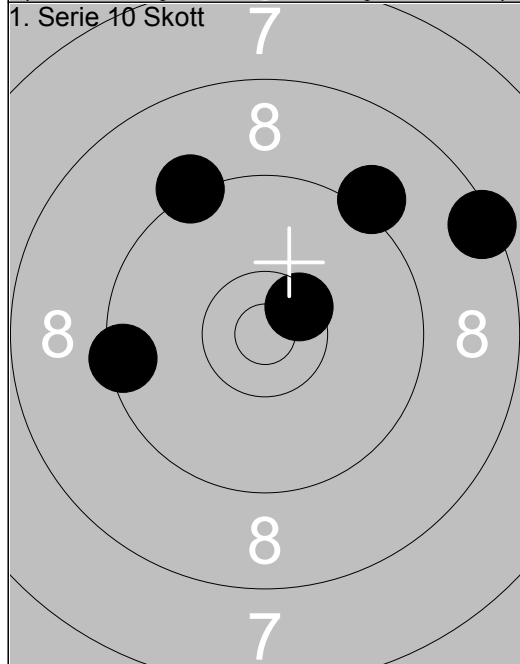

1:	*10.5	↗
2:	9.3	↖
3:	9.5	←
4:	8.4	↗
5:	9.2	↗
Serie		45.0
Total		216.0

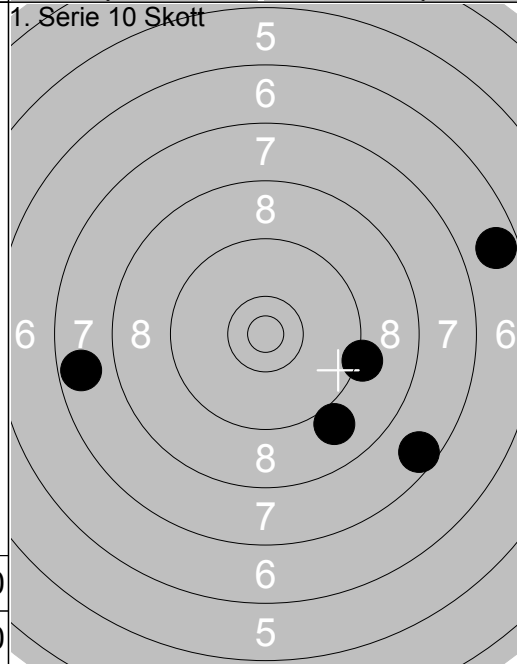

6:	7.6	↘
7:	9.2	→
8:	9.0	↘
9:	6.7	↗
10:	7.7	←
Serie		38.0
Total		254.0

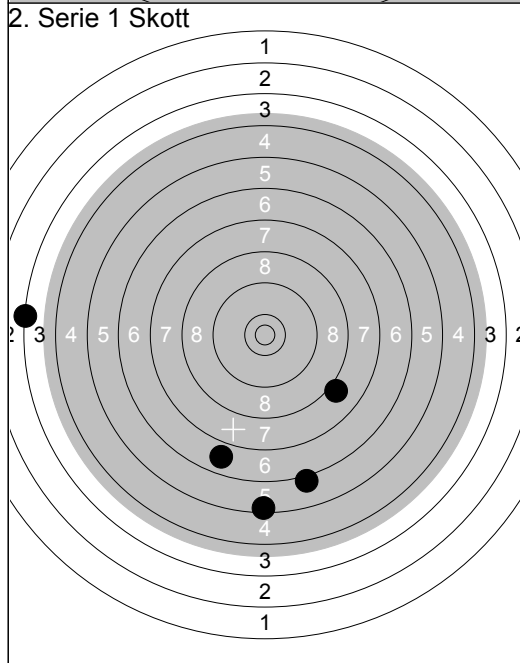

1:	6.8	↓
2:	6.1	↓
3:	8.1	↘
4:	5.4	↓
5:	3.3	←
Serie		28.0
Total		282.0

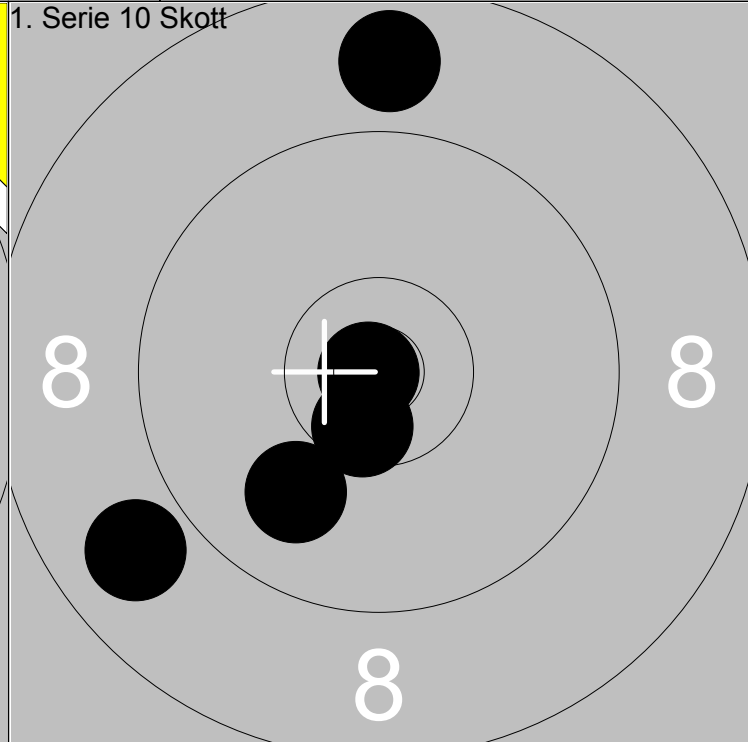
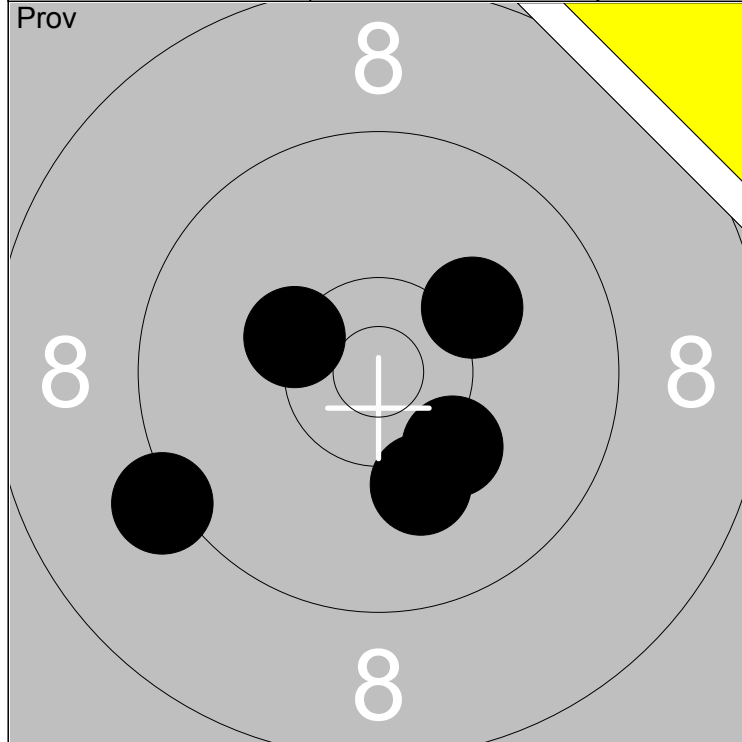

1: 10.2 ↘	Serie	49.0
2: 10.2 ↗		
3: 10.1 ↓	Total	171.0
4: 9.2 ↙		
5: *10.3 ↖		

1: 8.9 ↙	Serie	45.0
2: *10.6 ↓		
3: 9.9 ↘	Total	216.0
4: *10.9 ↖		
5: 8.8 ↑		

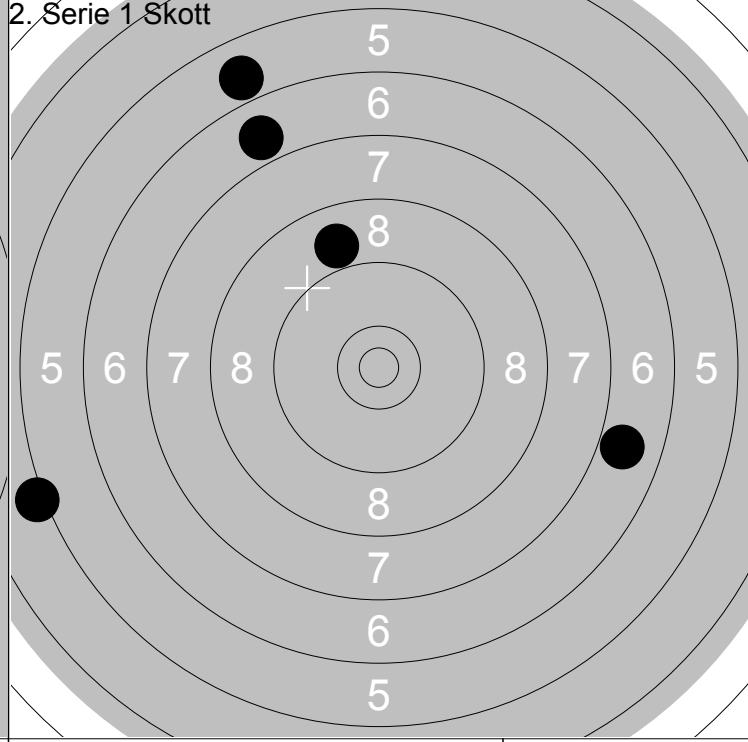
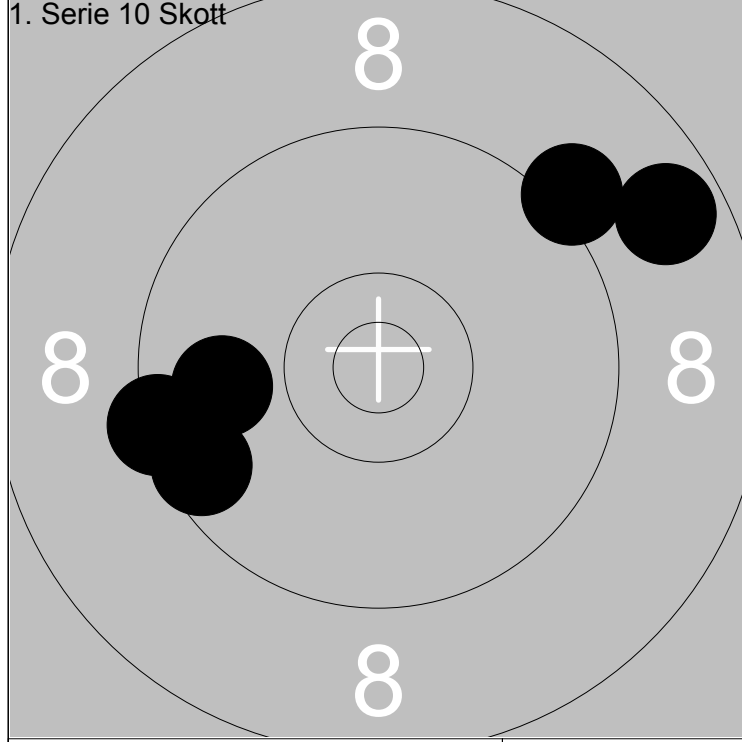

6: 9.9 ↙	Serie	44.0
7: 9.6 ↙		
8: 9.2 ↗	Total	260.0
9: 8.7 ↗		
10: 9.4 ↙		

1: 5.2 ↙	Serie	30.0
2: 5.9 ↗		
3: 6.9 →	Total	290.0
4: 8.9 ↗		
5: 6.9 ↗		

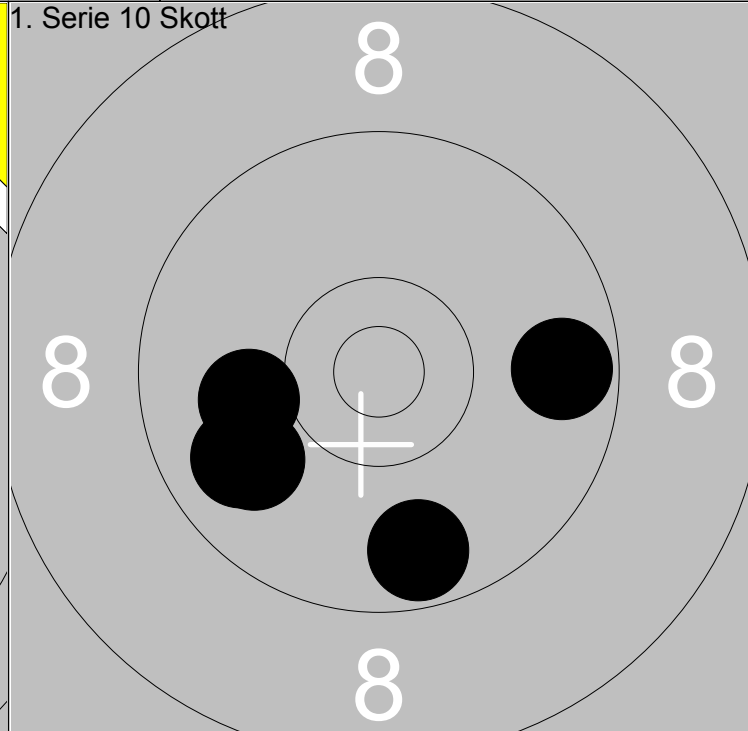
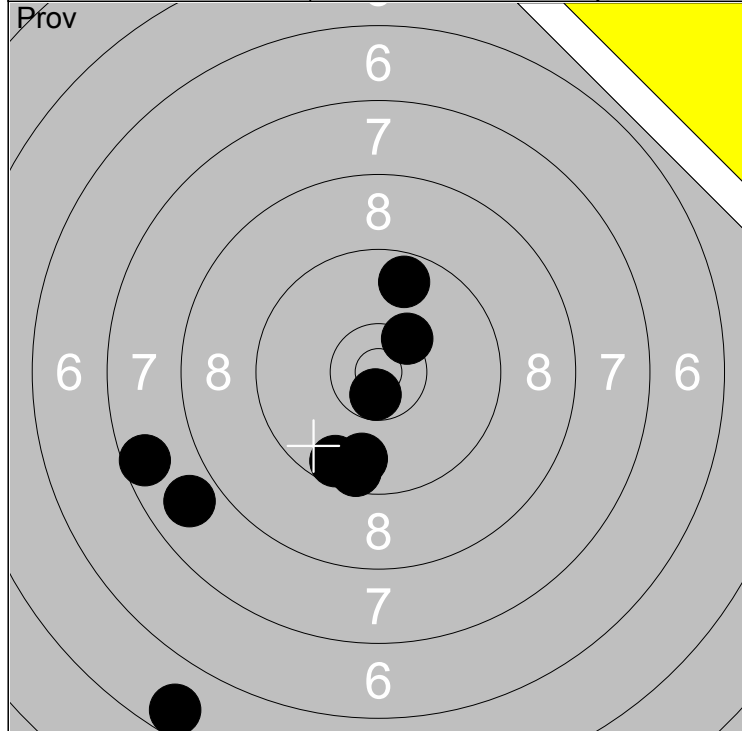

1: 9.6 ↓	6: 9.8 ↓	Serie	75.0
2: 7.6 ←	7: 5.7 ↓		
3: *10.4 ↗	8: *10.6 ↓	Total	161.0
4: 7.9 ←	9: 9.7 ↑		
5: 9.6 ↓			

1: 9.7 ↓	Serie	46.0
2: 9.9 ←		
3: 10.0 ←	Total	207.0
4: 9.8 ←		
5: 9.7 →		

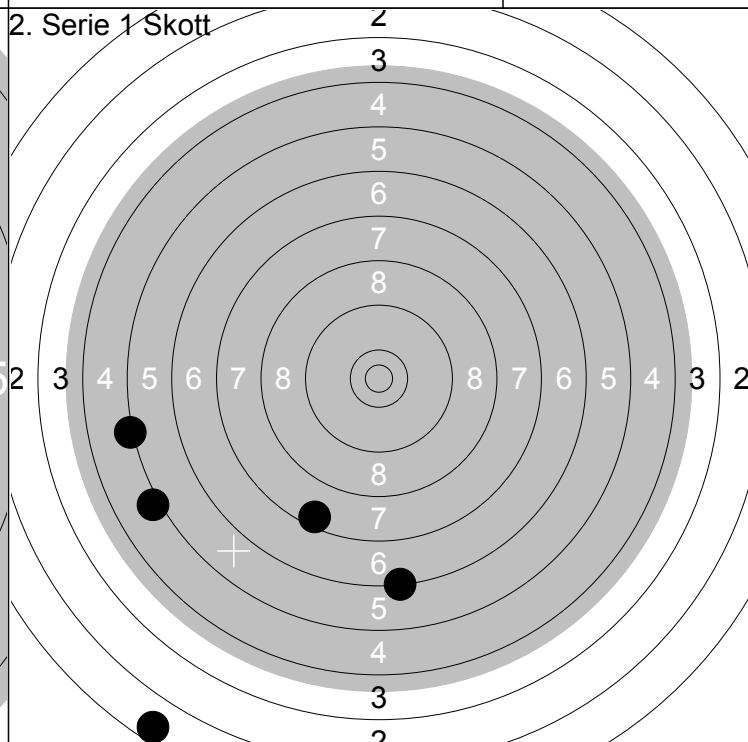
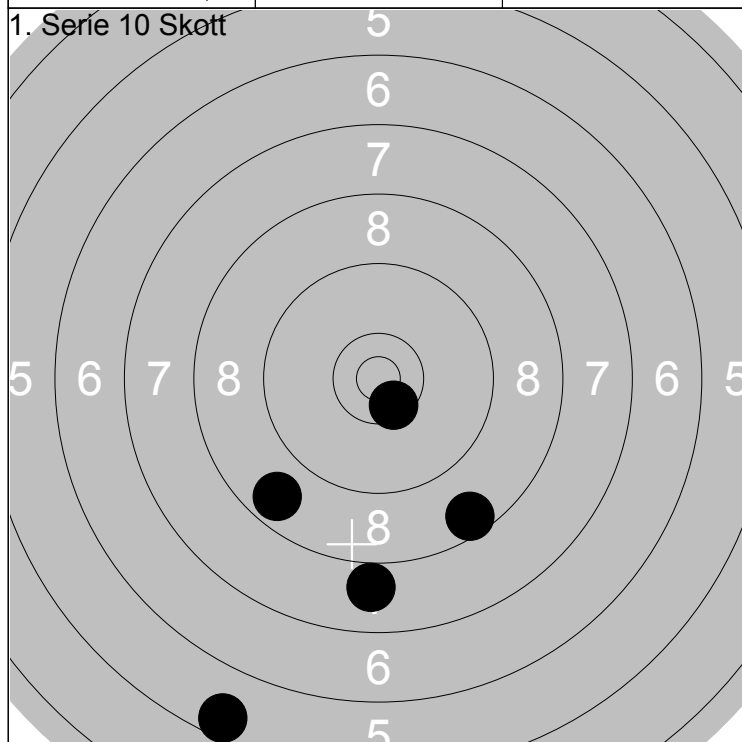

6: 8.6 ↓	Serie	38.0
7: 7.9 ↓		
8: 8.7 ←	Total	245.0
9: 5.6 ↓		
10: *10.5 ↓		

1: 7.5 ↓	Serie	24.0
2: 6.3 ↓		
3: 5.1 ←	Total	269.0
4: 5.2 ←		
5: 1.6 ↓		

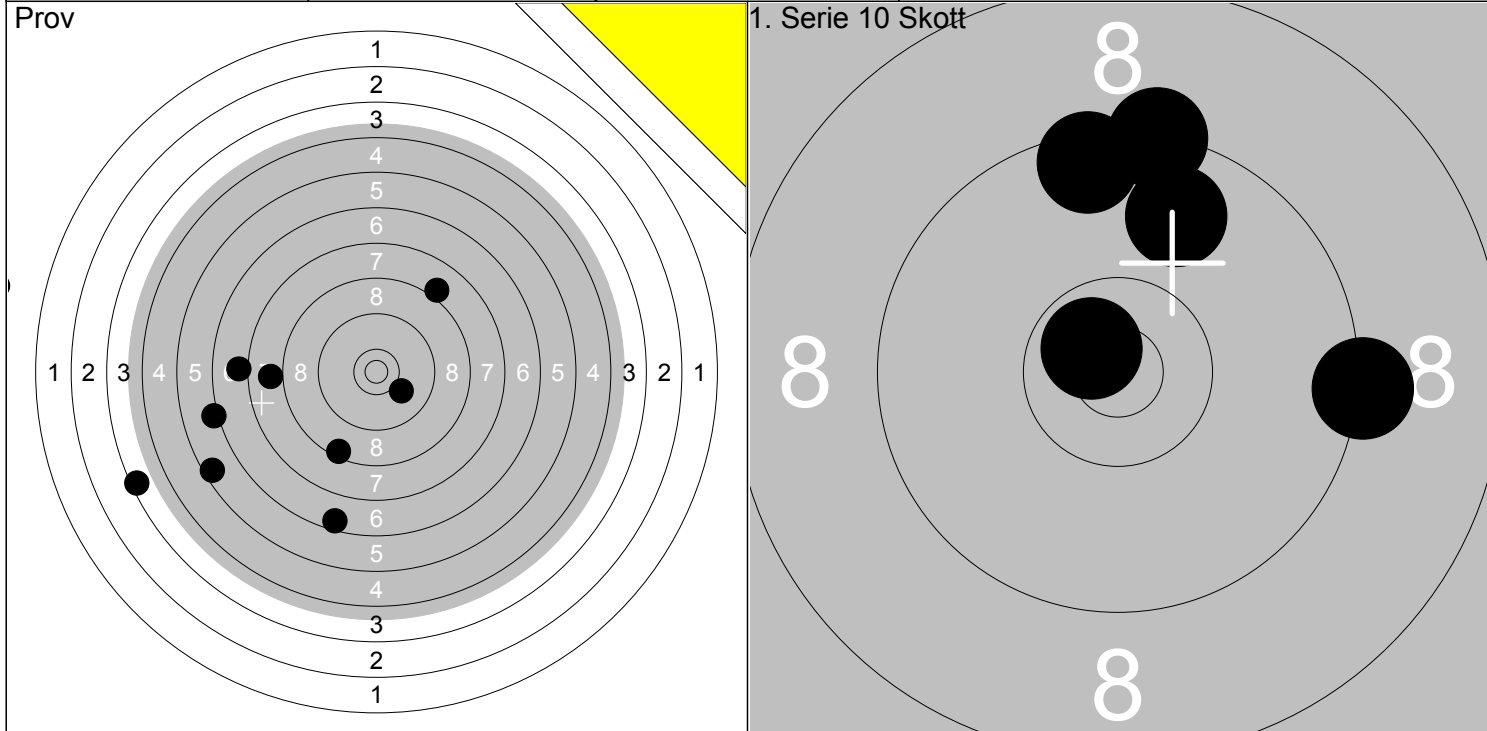

1: 8.1 ↗	6: 6.2 ←	Serie	60.0	1: 9.3 →	Serie	46.0
2: 7.9 ←	7: 5.5 ↙			2: 9.5 ↑		
3: 0.0 ←	8: 6.6 ↓	Total	151.0	3: 9.8 ↗	Total	197.0
4: 8.5 ↓	9: 7.1 ←			4: *10.7 ↖		
5: 10.1 ↘	10: 3.5 ←			5: 9.3 ↑		

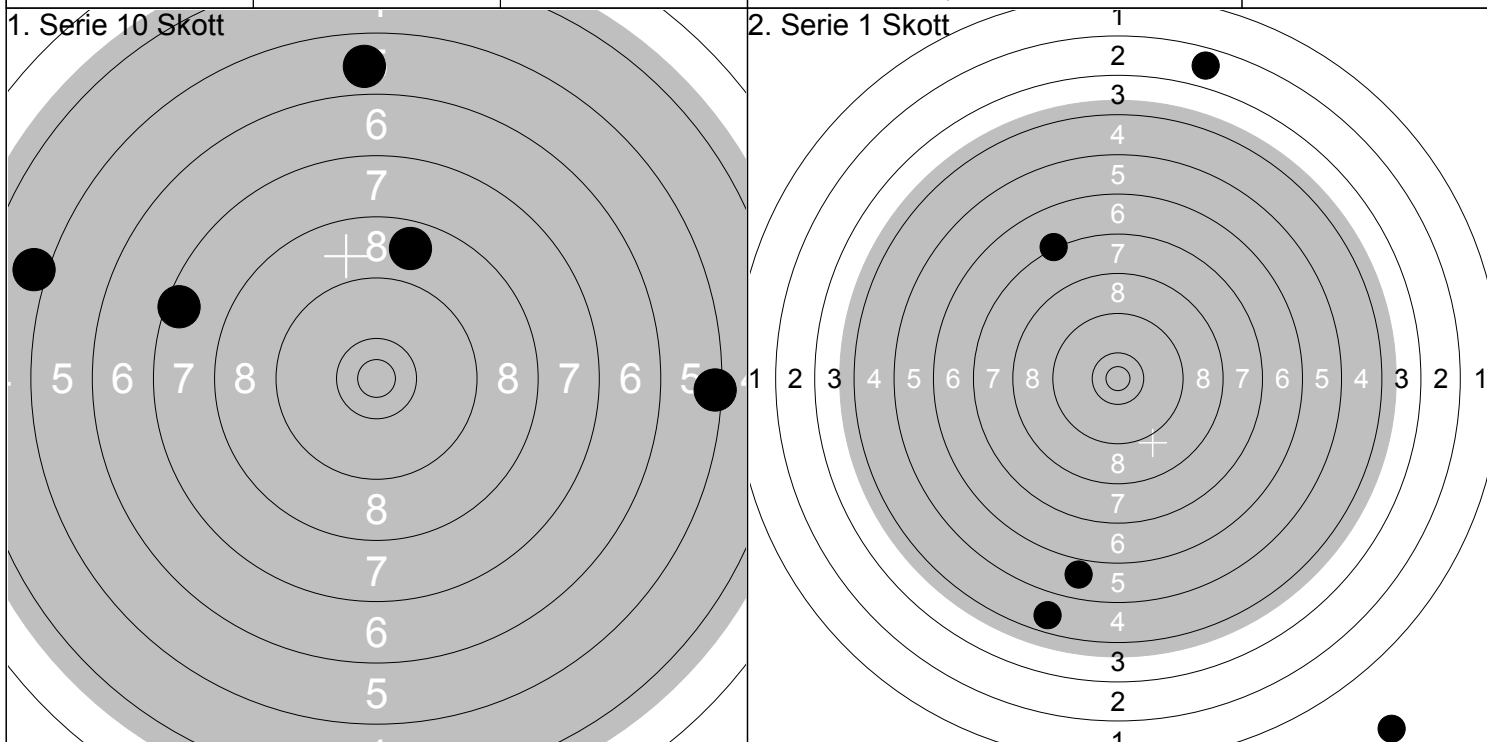

6: 5.4 →	Serie	30.0	1: 0.0 ↘	Serie	18.0
7: 5.8 ↑			2: 5.9 ↓		
8: 7.5 ←	Total	227.0	3: 7.2 ↗	Total	245.0
9: 8.7 ↑			4: 4.7 ↓		
10: 5.1 ←			5: 2.8 ↑		

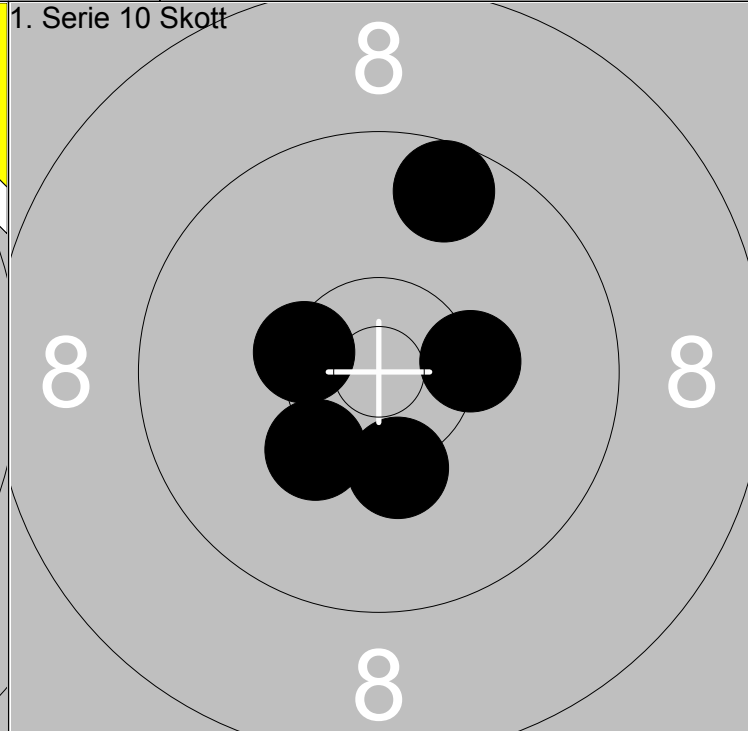
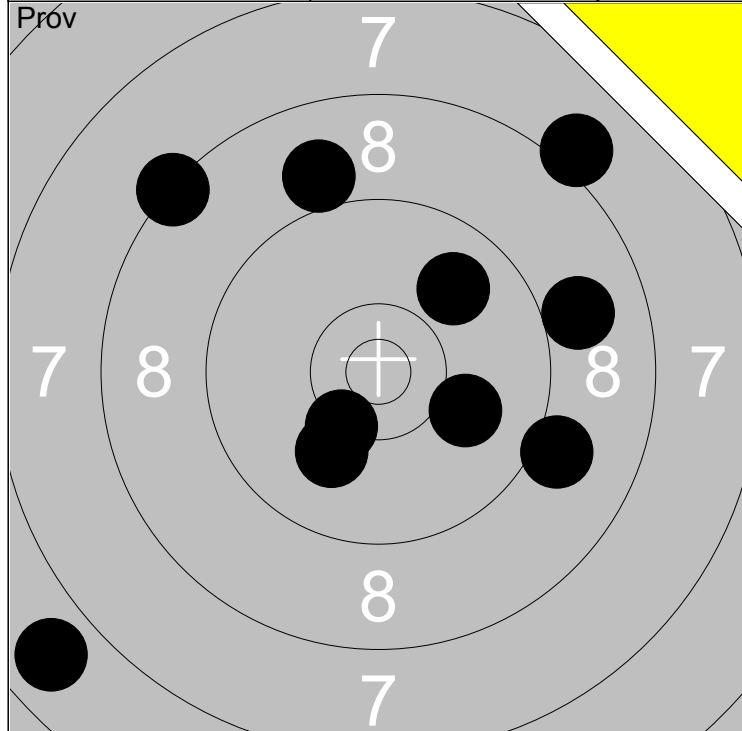

1: 9.0 ↑	6: 6.8 ↙	Serie	88.0
2: 9.0 →	7: 9.9 ↗		
3: 9.1 ➤	8: 10.0 ➡	Total	177.0
4: 8.1 ↗	9: 10.1 ↘		
5: 8.3 ↖	10: *10.3 ↘		

1: *10.4 ↖	Serie	49.0
2: 9.6 ↑		
3: 10.3 ↘	Total	226.0
4: *10.3 ➡		
5: 10.3 ↓		

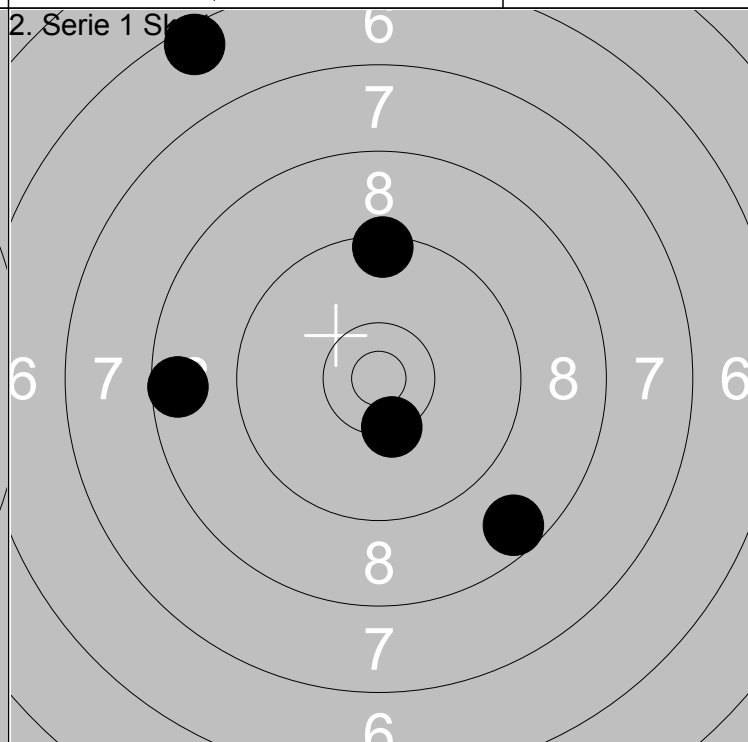
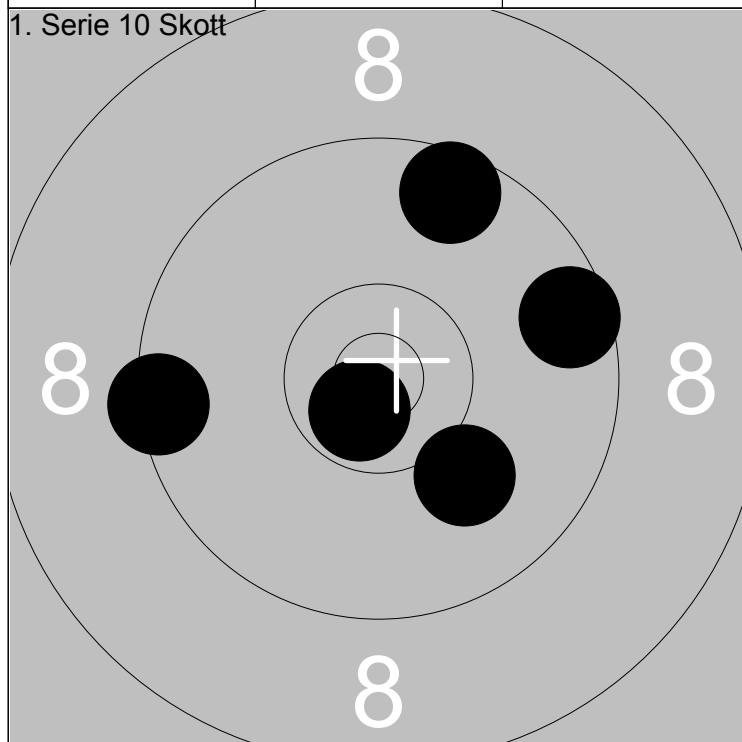

6: 9.6 →	Serie	47.0
7: 9.4 ←		
8: 9.6 ↑	Total	273.0
9: 10.1 ↘		
10: *10.7 ↘		

1: 9.4 ↑	Serie	41.0
2: 6.5 ↖		
3: *10.4 ↘	Total	314.0
4: 8.6 ←		
5: 8.6 ↘		

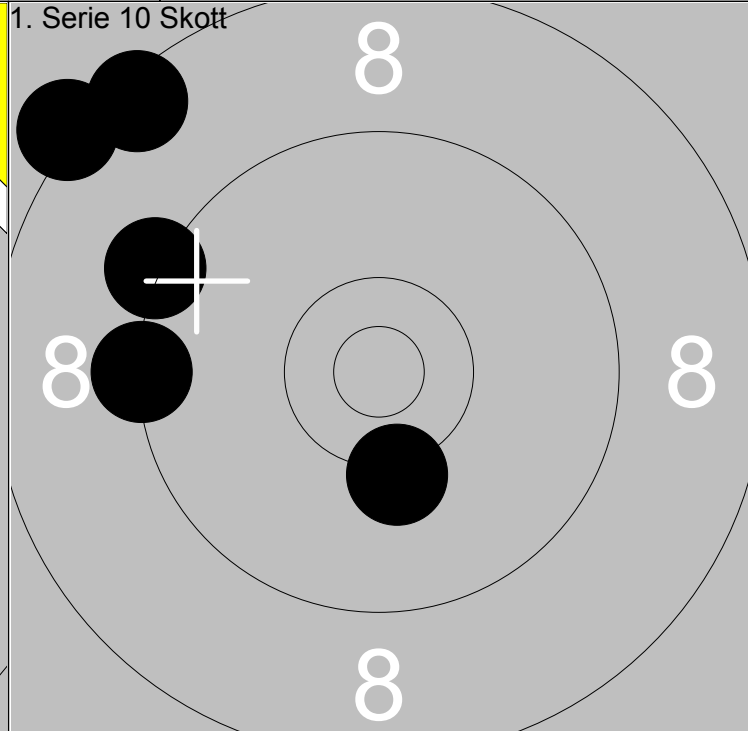
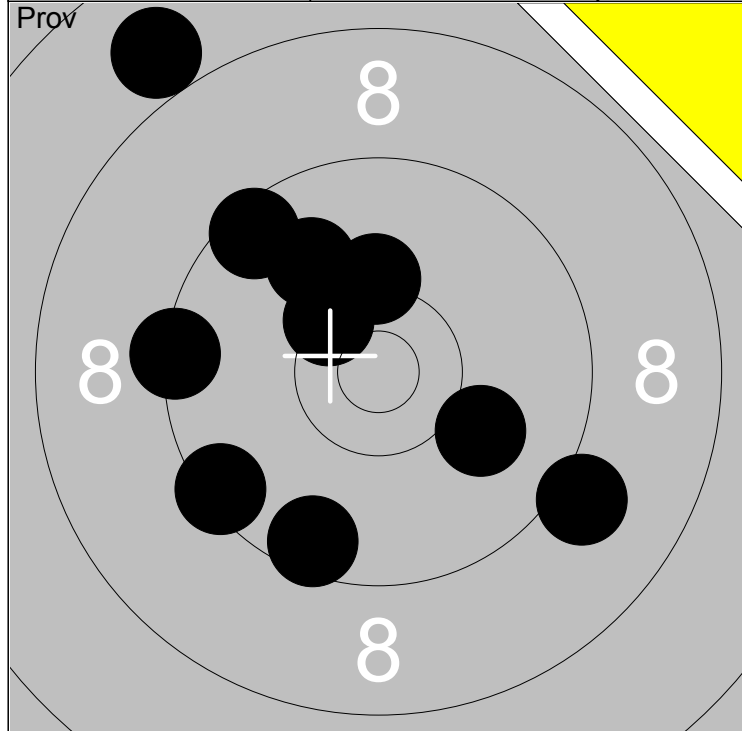

1: 7.9 ↗	6: 9.5 ↘	Serie	92.0
2: 9.4 ↙	7: 9.5 ↗		
3: 10.2 ↑	8: 10.0 ↘	Total	148.0
4: 10.0 ↗	9: 9.1 ↘		
5: 9.4 ←	10: *10.4 ↗		

1: 8.5 ↗	Serie	44.0
2: 8.2 ↗		
3: 10.2 ↘	Total	192.0
4: 9.3 ↗		
5: 9.3 ←		

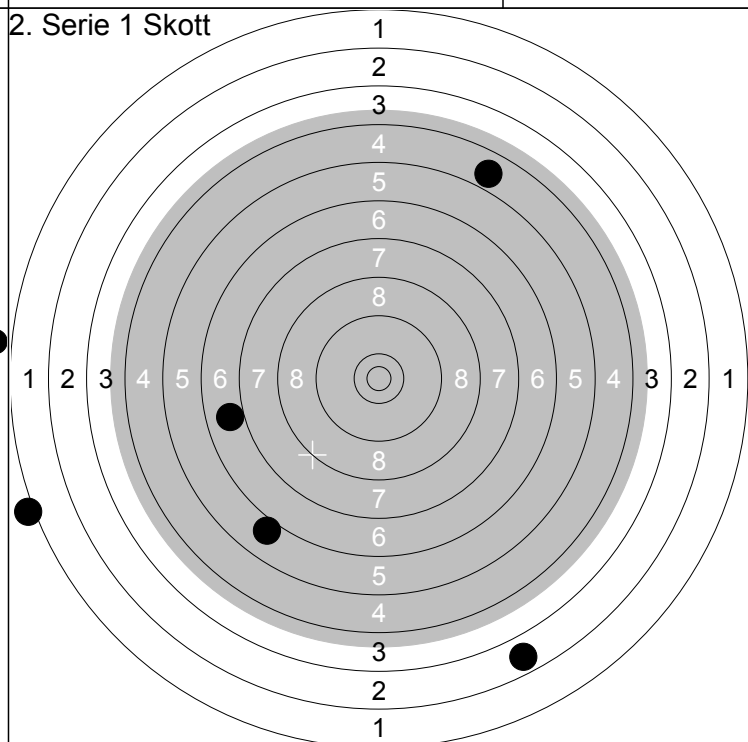
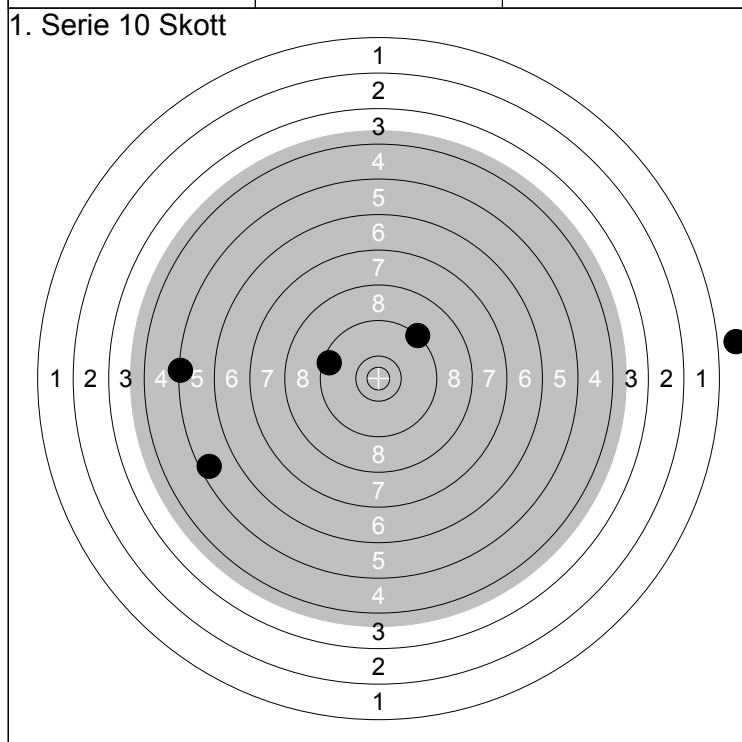

6: 9.5 ←	Serie	28.0
7: 5.3 ←		
8: 5.6 ←	Total	220.0
9: 0.0 →		
10: 9.3 ↗		

1: 4.9 ↗	Serie	19.0
2: 1.1 ←		
3: 6.0 ↘	Total	239.0
4: 6.9 ←		
5: 2.8 ↘		