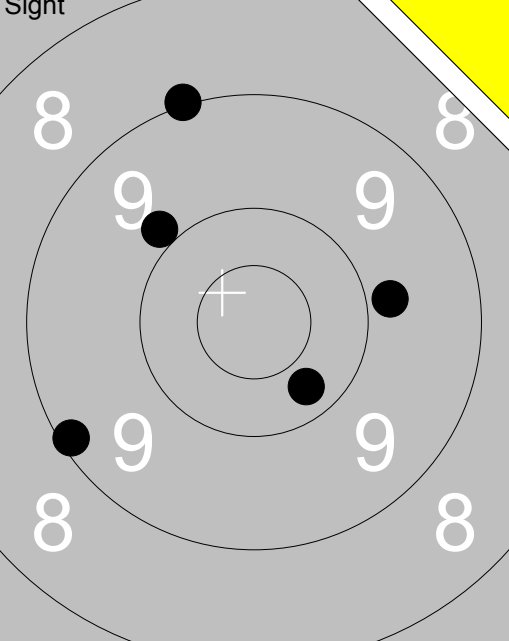
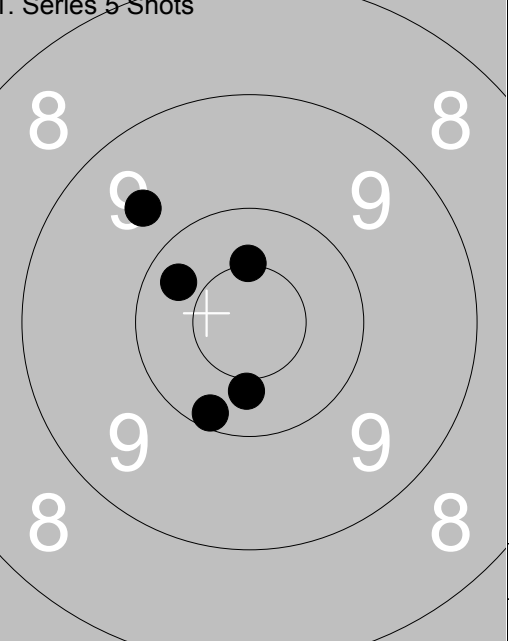
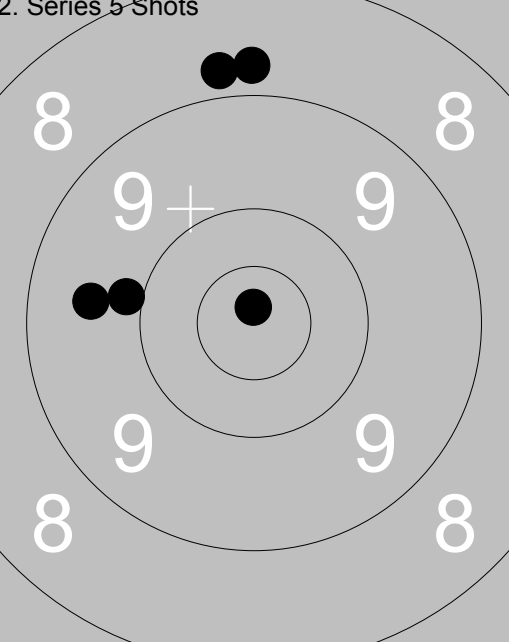
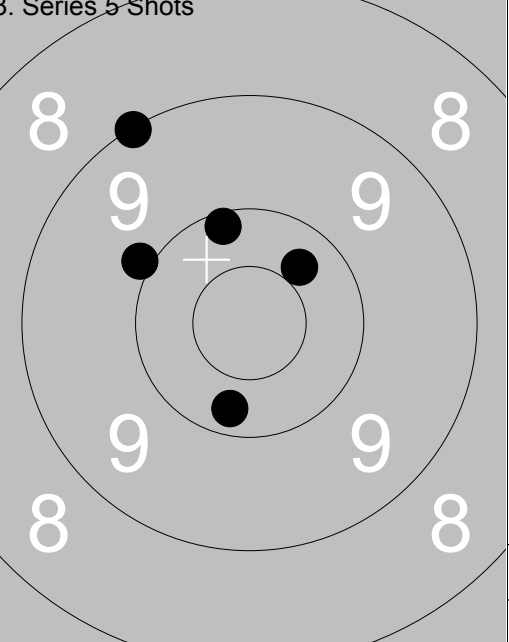
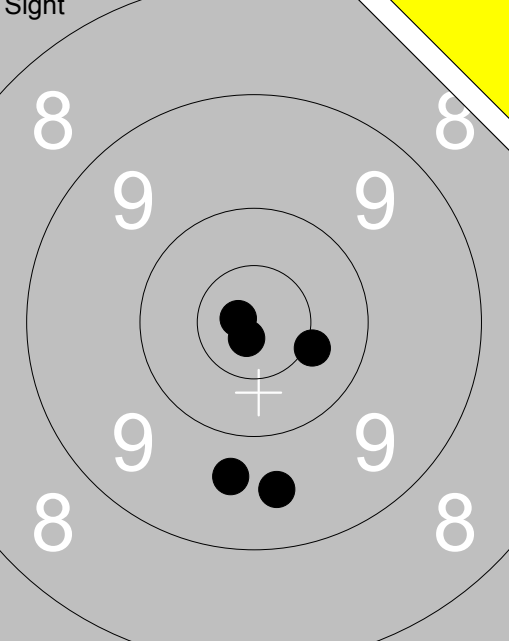
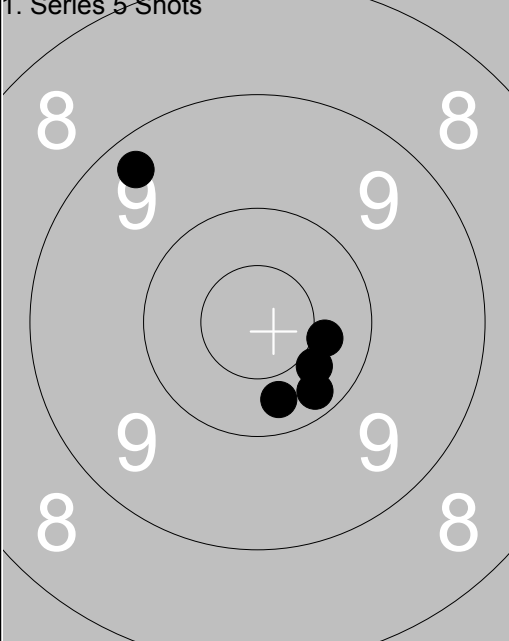
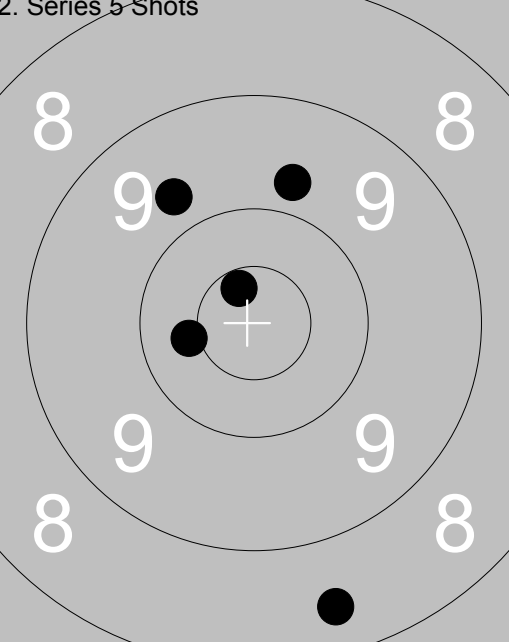
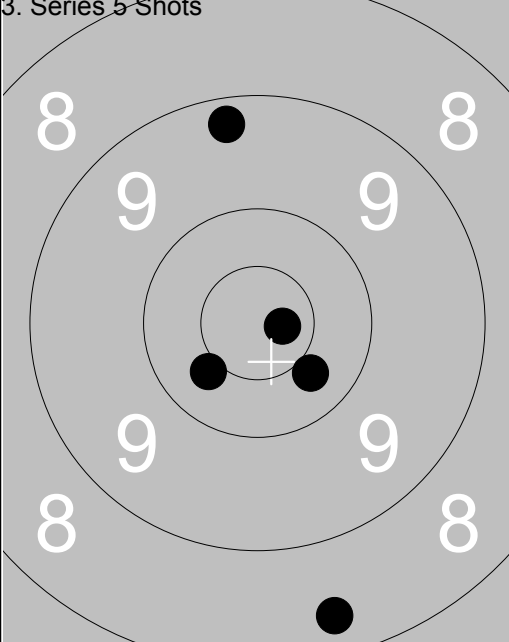

<p>Sight</p>  <p>1: 9.1 ↙ 2: 10.3 ↘ 3: 9.0 ↑ 4: 9.9 ↖ 5: 9.8 →</p> <table border="1" style="width:100%; border-collapse: collapse;"> <tr><td>Series</td><td style="text-align: right;">46.0</td></tr> <tr><td>Total</td><td style="text-align: right;">0.0</td></tr> </table>	Series	46.0	Total	0.0	<p>1. Series 5 Shots</p>  <p>1: 9.7 ↖ 2: 10.4 ↓ 3: 10.1 ↘ 4: 10.3 ↖ 5: *10.5 ↑</p> <table border="1" style="width:100%; border-collapse: collapse;"> <tr><td>Series</td><td style="text-align: right;">49.0</td></tr> <tr><td>Total</td><td style="text-align: right;">49.0</td></tr> </table>	Series	49.0	Total	49.0	
Series	46.0									
Total	0.0									
Series	49.0									
Total	49.0									

<p>2. Series 5 Shots</p>  <p>1: 9.9 ↙ 2: 8.8 ↑ 3: 8.8 ↑ 4: *10.8 ↑ 5: 9.6 ↙</p> <table border="1" style="width:100%; border-collapse: collapse;"> <tr><td>Series</td><td style="text-align: right;">44.0</td></tr> <tr><td>Total</td><td style="text-align: right;">93.0</td></tr> </table>	Series	44.0	Total	93.0	<p>3. Series 5 Shots</p>  <p>1: 10.1 ↑ 2: 9.0 ↖ 3: 10.3 ↗ 4: 10.2 ↓ 5: 9.9 ↖</p> <table border="1" style="width:100%; border-collapse: collapse;"> <tr><td>Series</td><td style="text-align: right;">48.0</td></tr> <tr><td>Total</td><td style="text-align: right;">141.0</td></tr> </table>	Series	48.0	Total	141.0	
Series	44.0									
Total	93.0									
Series	48.0									
Total	141.0									

<p>4. Series 10 Shots</p>  <p>1: 8.9 ↗ 2: 9.5 ↗ 3: 6.5 → 4: 9.3 → 5: 7.8 →</p> <table border="1" style="width:100%; border-collapse: collapse;"> <tr><td>Series</td><td style="text-align: right;">39.0</td></tr> <tr><td>Total</td><td style="text-align: right;">180.0</td></tr> </table>	Series	39.0	Total	180.0	<p>4. Series 10 Shots</p>  <p>6: 8.1 ↗ 7: 8.6 → 8: 8.1 → 9: 9.1 → 10: 9.0 →</p> <table border="1" style="width:100%; border-collapse: collapse;"> <tr><td>Series</td><td style="text-align: right;">42.0</td></tr> <tr><td>Total</td><td style="text-align: right;">222.0</td></tr> </table>	Series	42.0	Total	222.0	
Series	39.0									
Total	180.0									
Series	42.0									
Total	222.0									

<p>Sight</p> 	<p>1: *10.4 ↘ 2: 9.7 ↓ 3: 9.6 ↓ 4: *10.8 ↘ 5: *10.8 ↘</p>	<p>1. Series 5 Shots</p> 		<p>1: 9.3 ↗ 2: 10.2 ↘ 3: 10.3 ↘ 4: 10.4 → 5: 10.4 ↘</p>
Series 48.0				Series 49.0
Total 0.0				Total 49.0

<p>2. Series 5 Shots</p> 	<p>1: 9.7 ↗ 2: 9.7 ↗ 3: *10.6 ↗ 4: 10.4 ← 5: 8.4 ↓</p>	<p>3. Series 5 Shots</p> 		<p>1: 9.3 ↑ 2: 8.4 ↓ 3: 10.4 ↙ 4: 10.4 ↘ 5: *10.7 →</p>
Series 46.0				Series 47.0
Total 95.0				Total 142.0

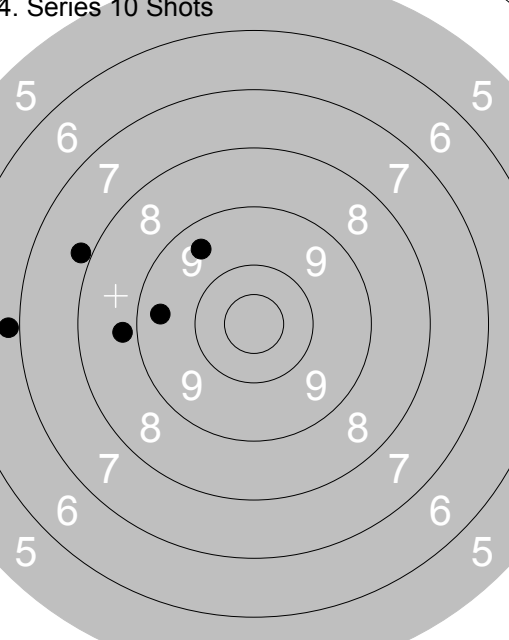
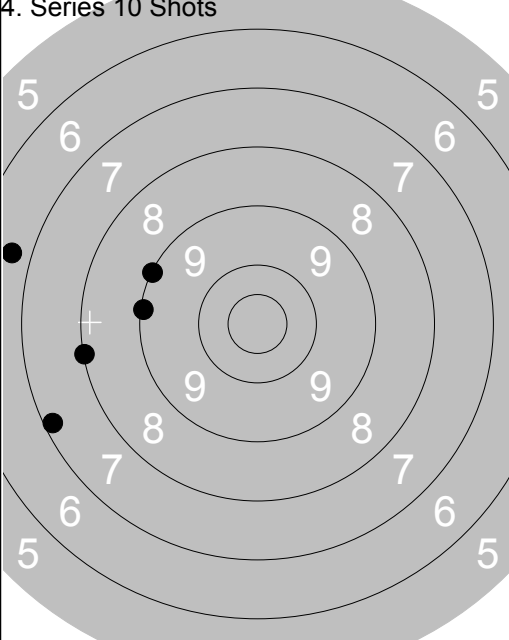
<p>4. Series 10 Shots</p> 	<p>1: 9.4 ← 2: 6.8 ← 3: 9.5 ↗ 4: 7.8 ← 5: 8.8 ←</p>	<p>4. Series 10 Shots</p> 		<p>6: 6.7 ← 7: 9.1 ↙ 8: 9.1 ← 9: 7.2 ↙ 10: 8.0 ←</p>
Series 39.0				Series 39.0
Total 181.0				Total 220.0

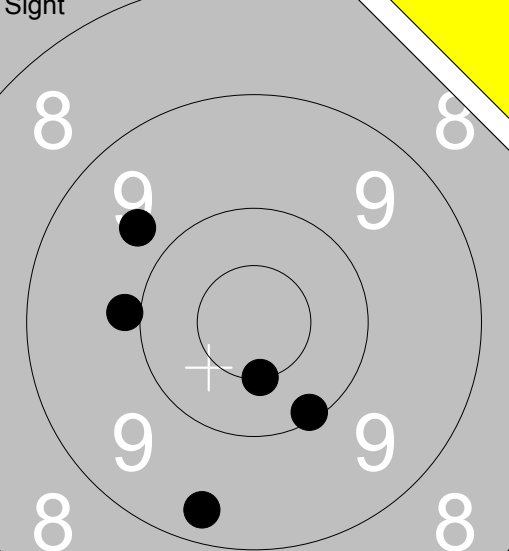
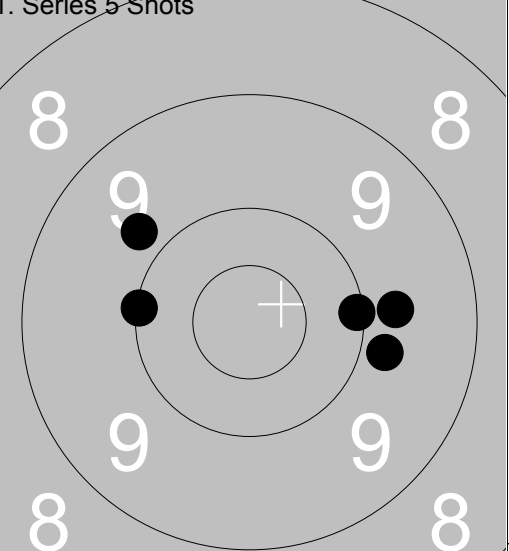
<p>Sight</p> 	<p>1: 9.9 ← 2: *10.5 ↓ 3: 9.7 ↖ 4: 10.1 ↓ 5: 9.3 ↓</p>	<p>1. Series 5 Shots</p> 	<p>1: 9.7 → 2: 9.8 ↖ 3: 10.0 ← 4: 9.8 → 5: 10.1 →</p>
Series 47.0		Series 47.0	
Total 0.0		Total 47.0	

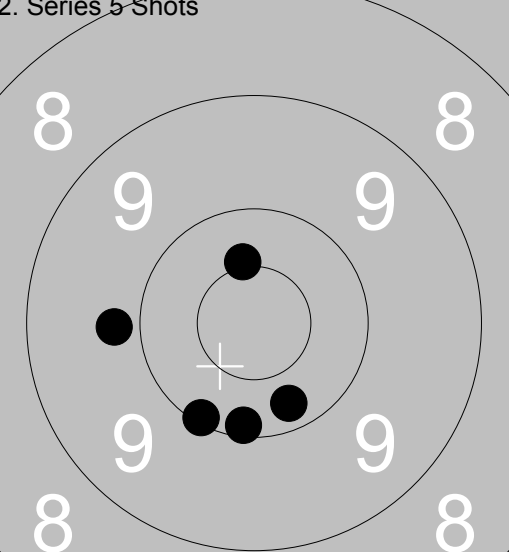
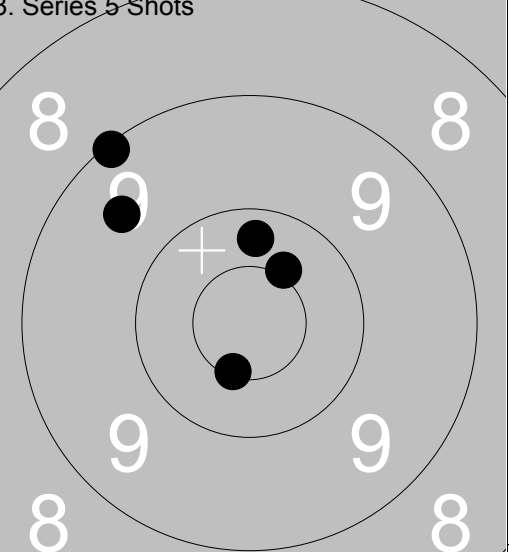
<p>2. Series 5 Shots</p> 	<p>1: 10.1 ↓ 2: 10.2 ↓ 3: 9.8 ← 4: *10.4 ↑ 5: 10.1 ↓</p>	<p>3. Series 5 Shots</p> 	<p>1: 9.1 ↖ 2: *10.4 ↗ 3: 10.3 ↑ 4: *10.5 ↓ 5: 9.6 ↖</p>
Series 49.0		Series 48.0	
Total 96.0		Total 144.0	

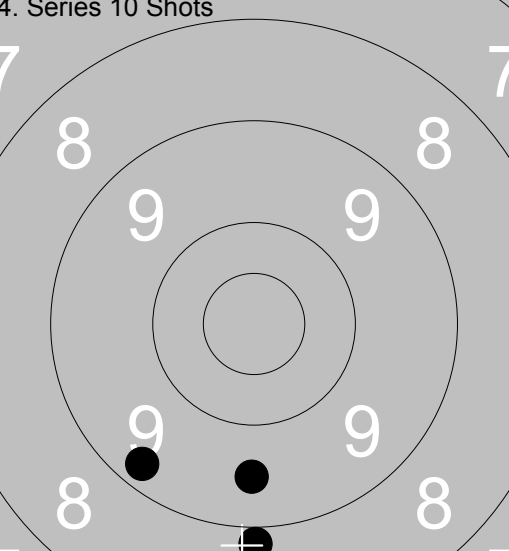
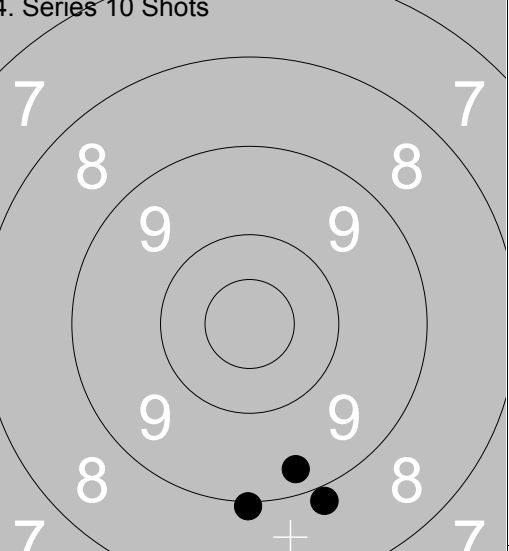
<p>4. Series 10 Shots</p> 	<p>1: 9.3 ↓ 2: 9.5 ↓ 3: 8.2 ↓ 4: 8.9 ↓ 5: 7.8 ↓</p>	<p>4. Series 10 Shots</p> 	<p>6: 9.3 ↓ 7: 7.4 ↓ 8: 9.0 ↓ 9: 8.9 ↓ 10: 8.1 ↓</p>
Series 41.0		Series 41.0	
Total 185.0		Total 226.0	

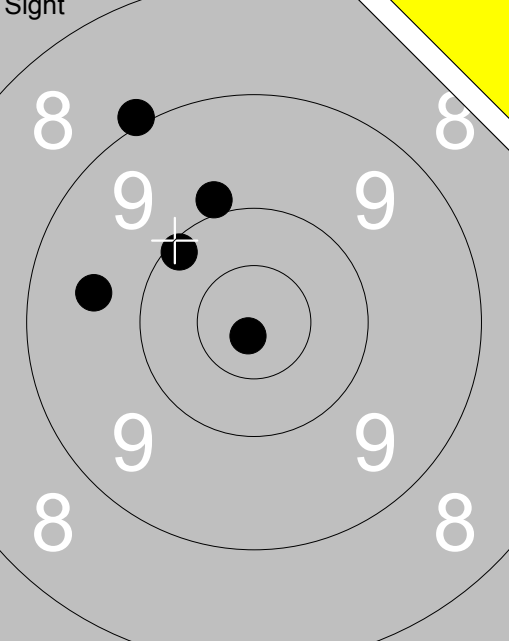
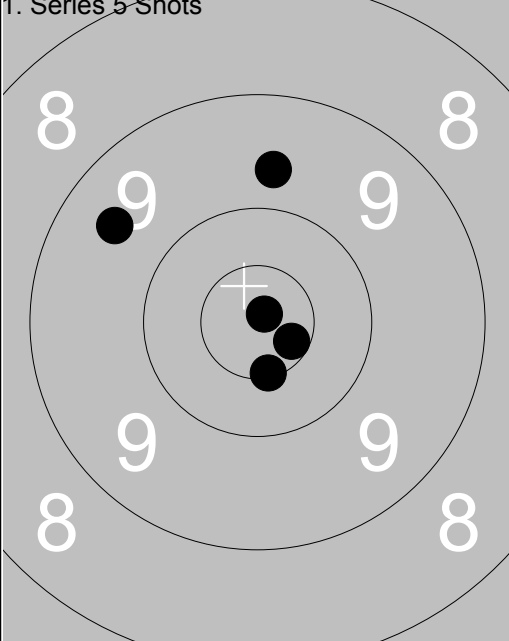
<p>Sight</p> 	<p>1. Series 5 Shots</p> 	<p>1: *10.8 ↘ 2: 9.9 ↑ 3: 10.1 ↘ 4: 9.0 ↑ 5: 9.6 ←</p> <p>1: 9.5 ↘ 2: *10.9 ↗ 3: 9.7 ↑ 4: *10.5 ↘ 5: *10.6 ↘</p>
Series 47.0	Series 48.0	
Total 0.0	Total 48.0	

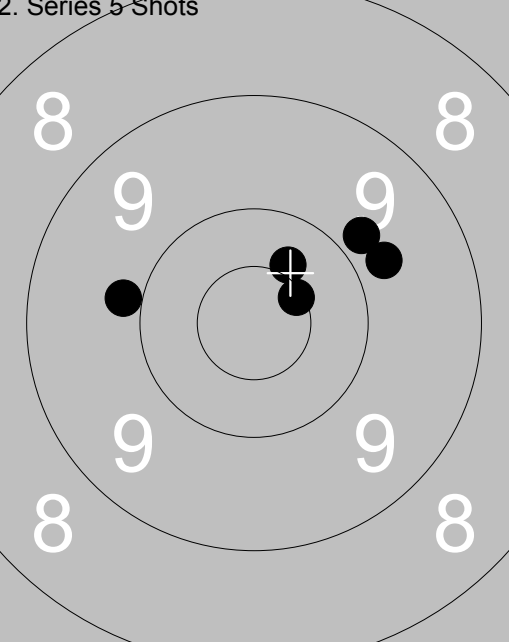
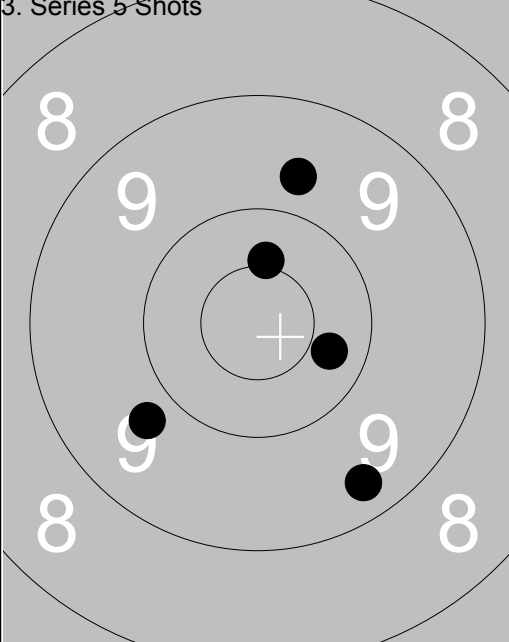
<p>2. Series 5 Shots</p> 	<p>3. Series 5 Shots</p> 	<p>1: 9.8 ↗ 2: 9.8 ↗ 3: 10.4 ↑ 4: *10.5 ↗ 5: 9.9 ←</p> <p>1: 9.7 ↑ 2: *10.4 ↑ 3: 10.3 → 4: 9.4 ↓ 5: 9.7 ↘</p>
Series 47.0	Series 47.0	
Total 95.0	Total 142.0	

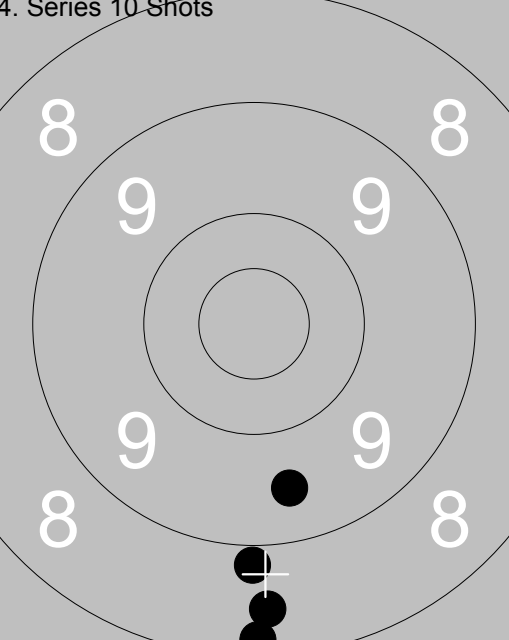
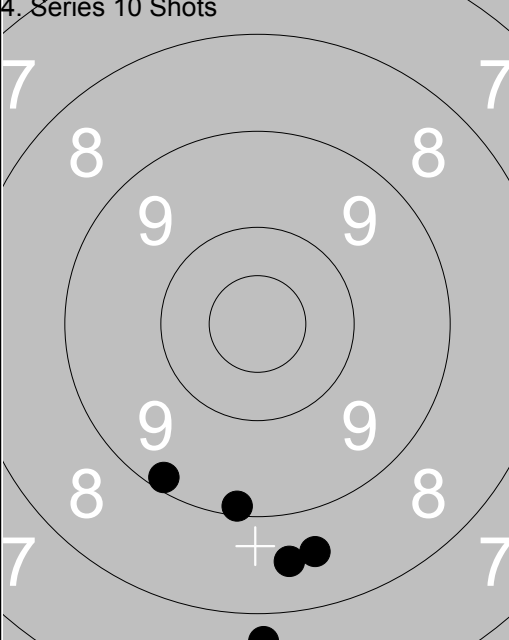
<p>4. Series 10 Shots</p> 	<p>4. Series 10 Shots</p> 	<p>1: 0.0 2: 8.2 ↓ 3: 8.4 ↓ 4: 8.9 ↓ 5: 9.5 ↓</p> <p>6: 8.6 ↓ 7: 9.1 ↓ 8: 9.2 ↘ 9: 8.6 ↓ 10: 7.7 ↓</p>
Series 33.0	Series 41.0	
Total 175.0	Total 216.0	

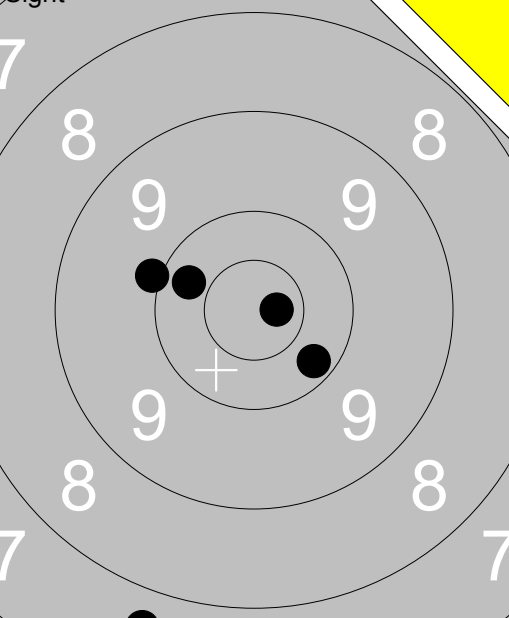
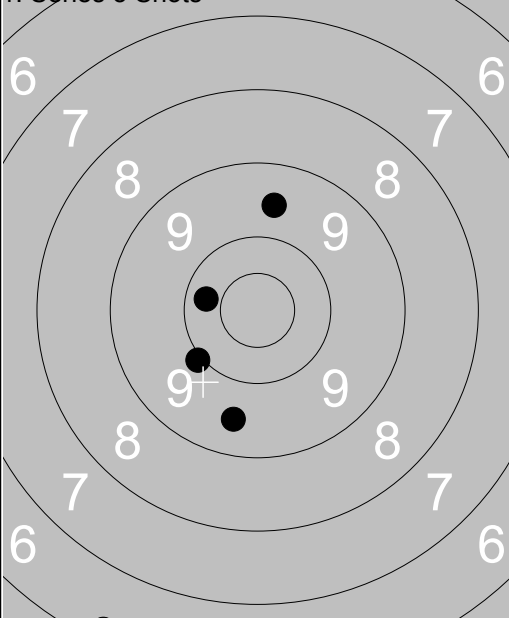
<p>Sight</p> 	<p>1: 7.6 ↓ 2: 10.3 ↙ 3: 9.9 ← 4: 10.2 ↘ 5: *10.7 →</p>	<p>1. Series 5 Shots</p> 		<p>1: 9.5 ↓ 2: 10.3 ↙ 3: 10.0 ↘ 4: 9.6 ↑ 5: 6.2 ↓</p>
Series 46.0		Series 44.0		
Total 0.0		Total 44.0		

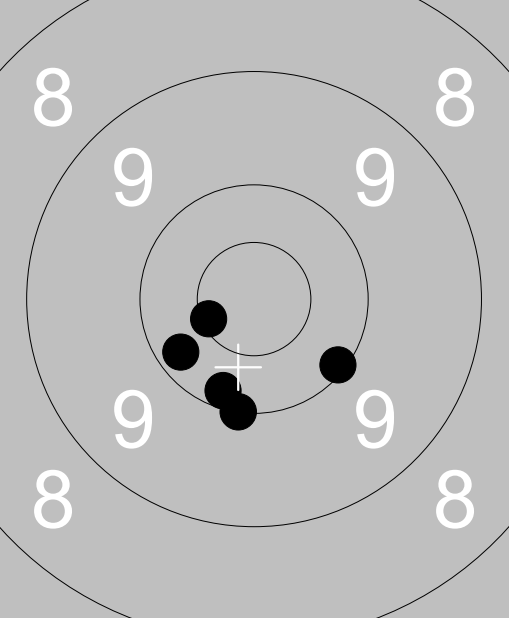
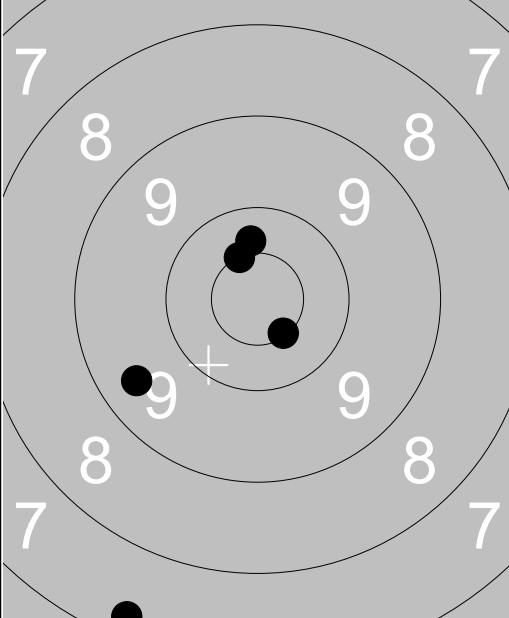
<p>2. Series 5 Shots</p> 	<p>1: 10.0 ↓ 2: *10.5 ↘ 3: 10.2 ↓ 4: 10.2 ↙ 5: 10.1 ↘</p>	<p>3. Series 5 Shots</p> 		<p>1: 7.3 ↓ 2: 10.4 ↑ 3: *10.5 ↘ 4: *10.5 ↙ 5: 9.4 ↙</p>
Series 50.0		Series 46.0		
Total 94.0		Total 140.0		

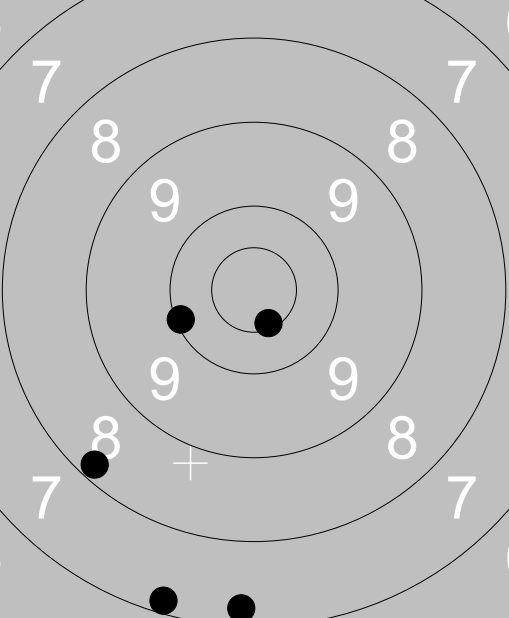
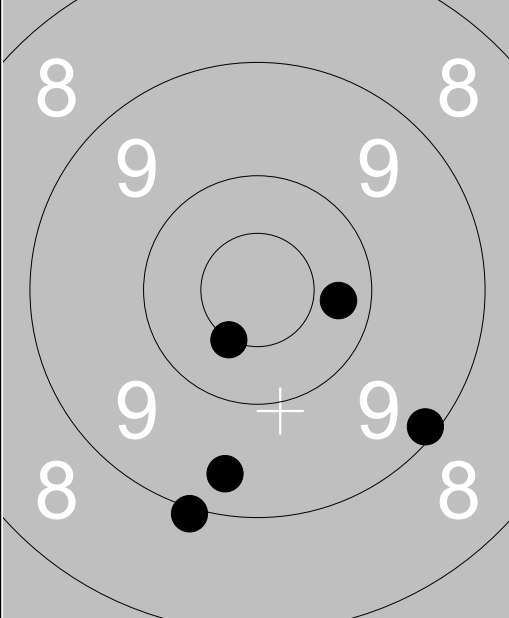
<p>4. Series 10 Shots</p> 	<p>1: 8.2 ↓ 2: *10.6 ↘ 3: 10.1 ↙ 4: 7.2 ↓ 5: 7.2 ↓</p>	<p>4. Series 10 Shots</p> 		<p>6: 10.3 → 7: 9.4 ↓ 8: 9.1 ↘ 9: 9.0 ↓ 10: *10.5 ↘</p>
Series 42.0		Series 47.0		
Total 182.0		Total 229.0		

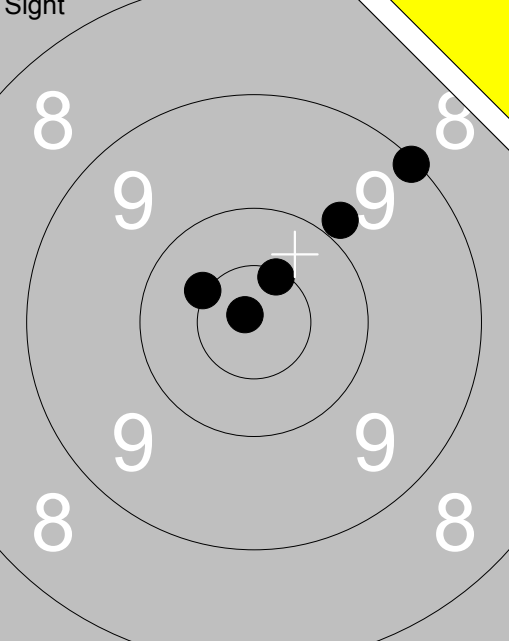
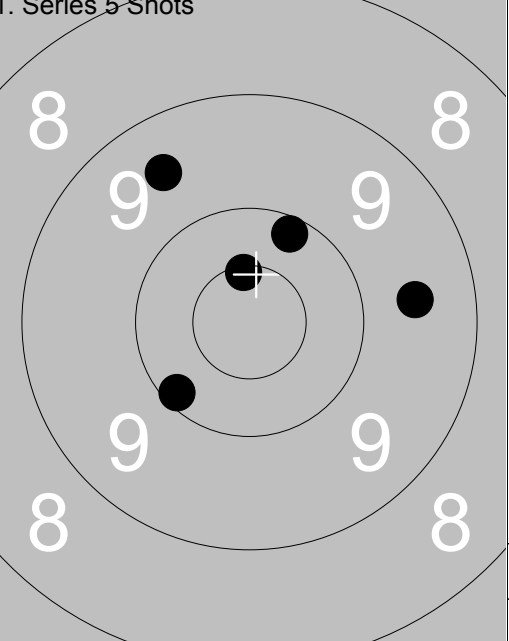
<p>Sight</p> 	<p>1: 9.1 ↗ 2: *10.5 ↗ 3: *10.5 ↘ 4: 9.9 ↗ 5: *10.9 ↘</p>	<p>1. Series 5 Shots</p> 	<p>1: 10.1 ↘ 2: 9.6 → 3: *10.5 ↗ 4: 10.2 ↗ 5: 9.5 ↖</p>
Series 48.0		Series 48.0	
Total 0.0		Total 48.0	

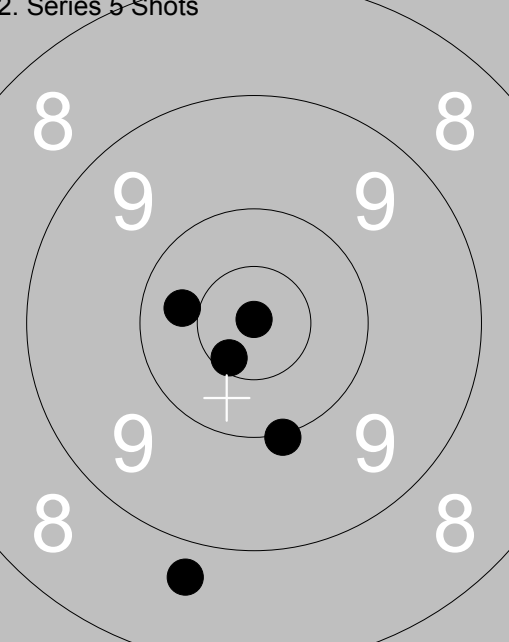
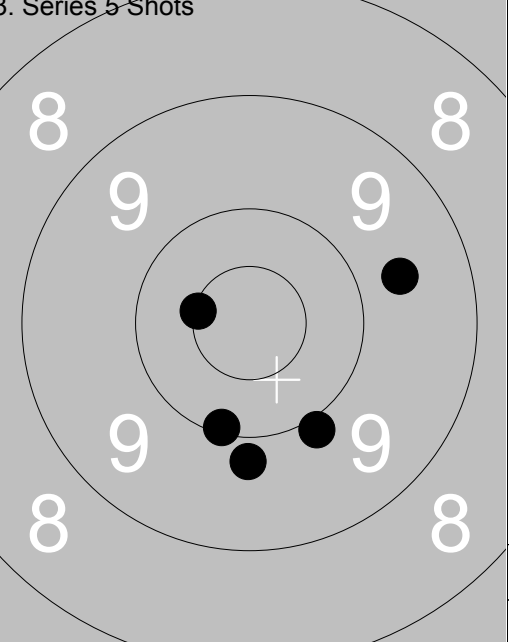
<p>2. Series 5 Shots</p> 	<p>1: *10.6 ↘ 2: 10.4 ← 3: *10.9 ↗ 4: 10.0 ↓ 5: 8.7 ↓</p>	<p>3. Series 5 Shots</p> 	<p>1: *10.5 ↘ 2: 10.1 ↓ 3: 9.6 → 4: 9.9 ↓ 5: 9.8 ↓</p>
Series 48.0		Series 47.0	
Total 96.0		Total 143.0	

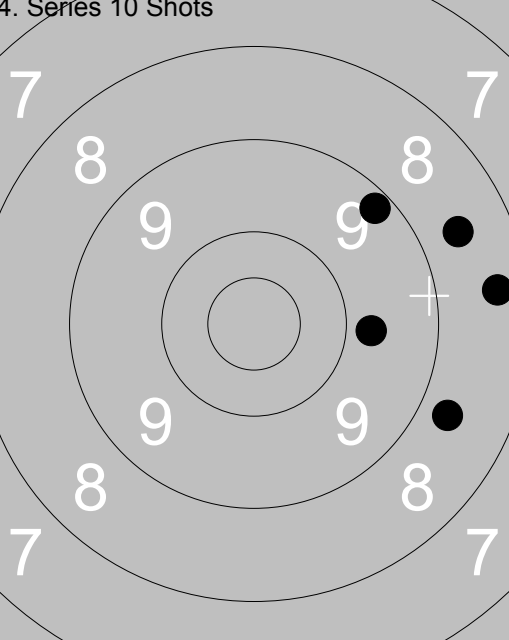
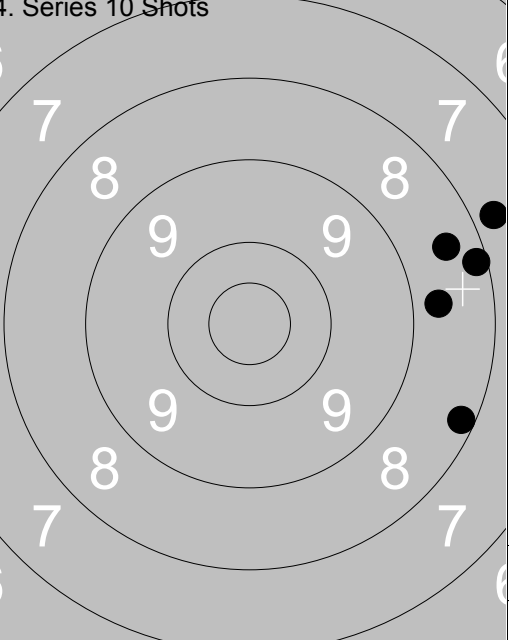
<p>4. Series 10 Shots</p> 	<p>1: 9.8 → 2: 8.6 → 3: 8.4 → 4: 8.7 → 5: 9.2 ↗</p>	<p>4. Series 10 Shots</p> 	<p>6: 8.5 → 7: 7.8 → 8: 8.2 → 9: 8.7 → 10: 8.2 →</p>
Series 42.0		Series 39.0	
Total 185.0		Total 224.0	

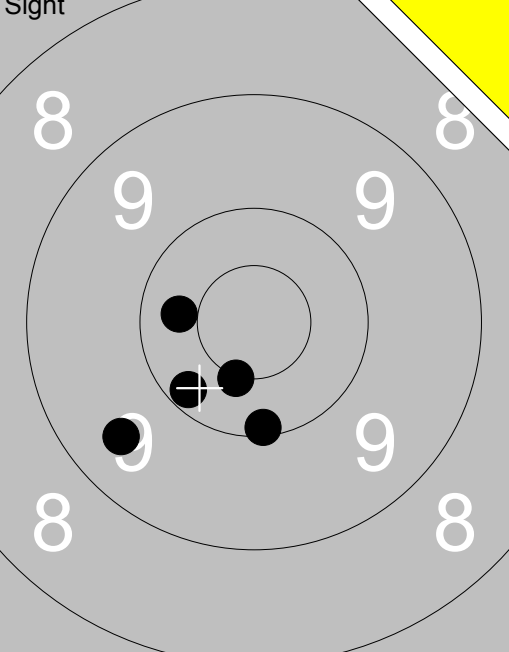
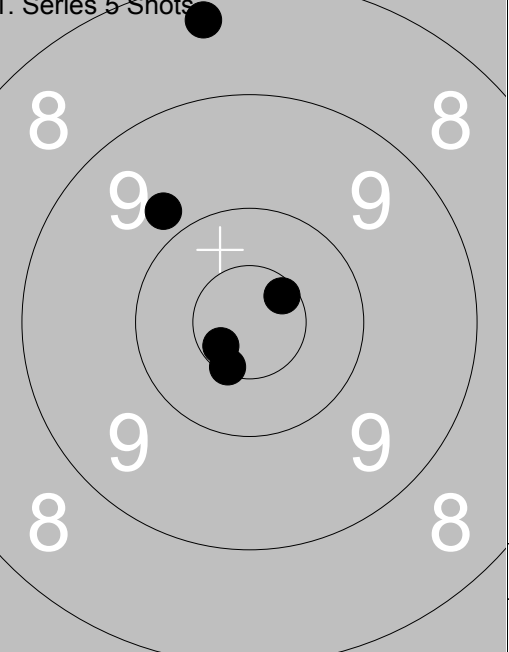
<p>Sight</p> 	<p>1: *10.5 ↙</p> <p>2: 9.5 ↙</p> <p>3: 10.3 ←</p> <p>4: 10.1 ↓</p> <p>5: 10.2 ↙</p>	<p>1. Series 5 Shots</p> 	<p>1: *10.6 ↙</p> <p>2: *10.5 ↙</p> <p>3: 9.8 ↖</p> <p>4: *10.6 ↗</p> <p>5: 8.3 ↑</p>
Series 49.0		Series 47.0	
Total 0.0		Total 47.0	

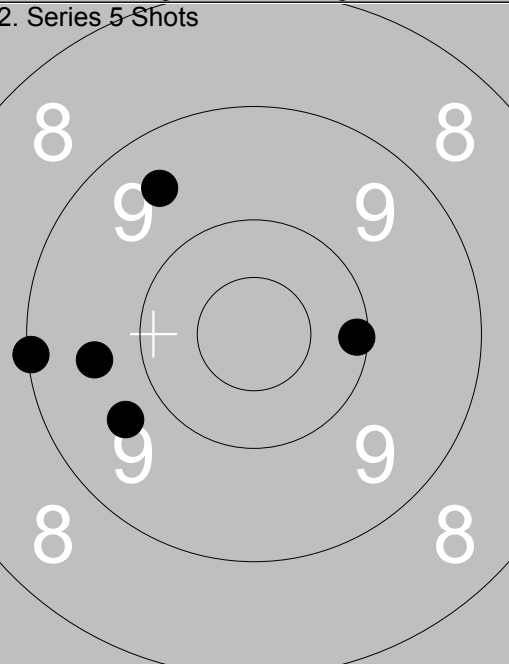
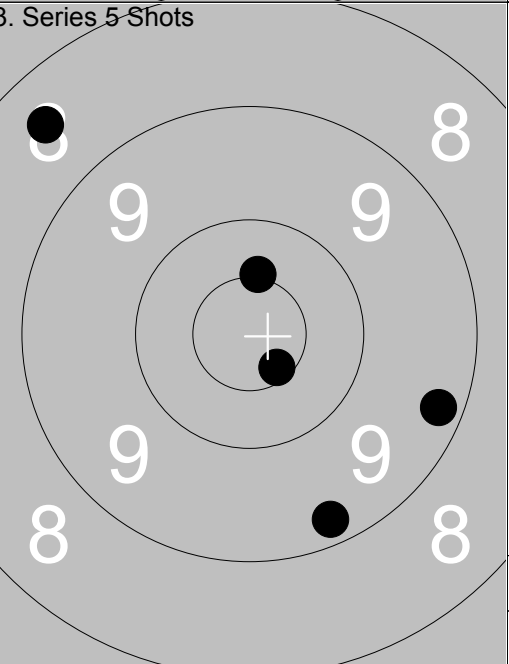
<p>2. Series 5 Shots</p> 	<p>1: 9.6 ←</p> <p>2: 10.1 →</p> <p>3: 9.7 ↙</p> <p>4: 9.5 ↖</p> <p>5: 9.1 ←</p>	<p>3. Series 5 Shots</p> 	<p>1: 8.5 ↖</p> <p>2: 9.3 →</p> <p>3: 9.3 ↓</p> <p>4: *10.5 ↑</p> <p>5: *10.6 ↘</p>
Series 46.0		Series 46.0	
Total 93.0		Total 139.0	

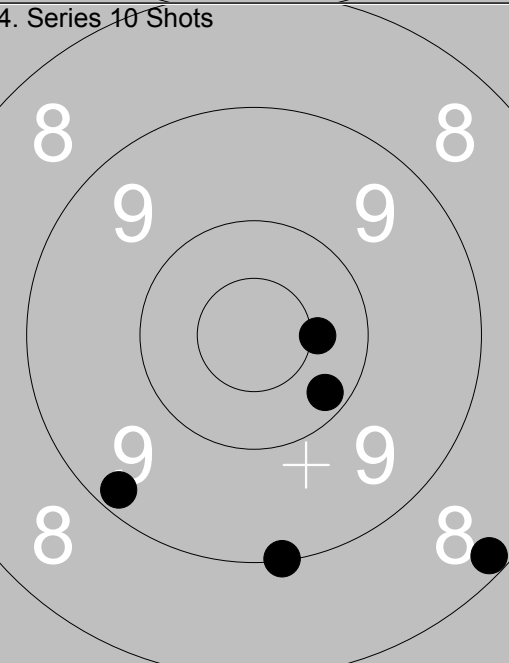
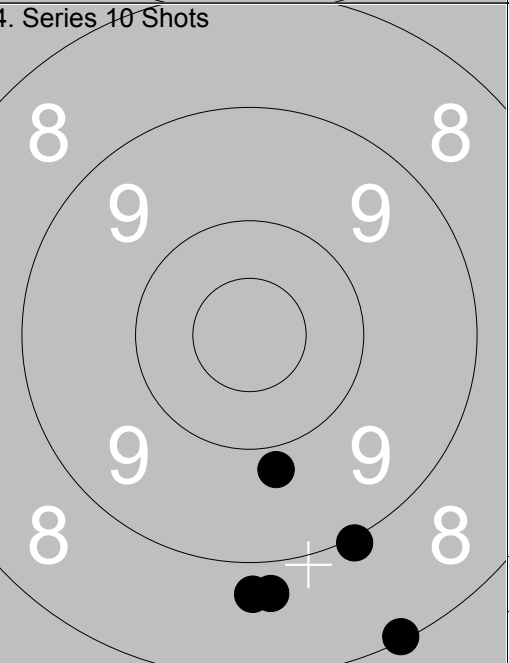
<p>4. Series 10 Shots</p> 	<p>1: 9.2 ↙</p> <p>2: 10.2 ↘</p> <p>3: 9.1 ↓</p> <p>4: *10.4 →</p> <p>5: 8.2 ↘</p>	<p>4. Series 10 Shots</p> 	<p>6: 8.8 ↓</p> <p>7: 9.8 ↓</p> <p>8: 8.1 ↓</p> <p>9: 9.0 ↓</p> <p>10: 8.8 ↓</p>
Series 46.0		Series 42.0	
Total 185.0		Total 227.0	

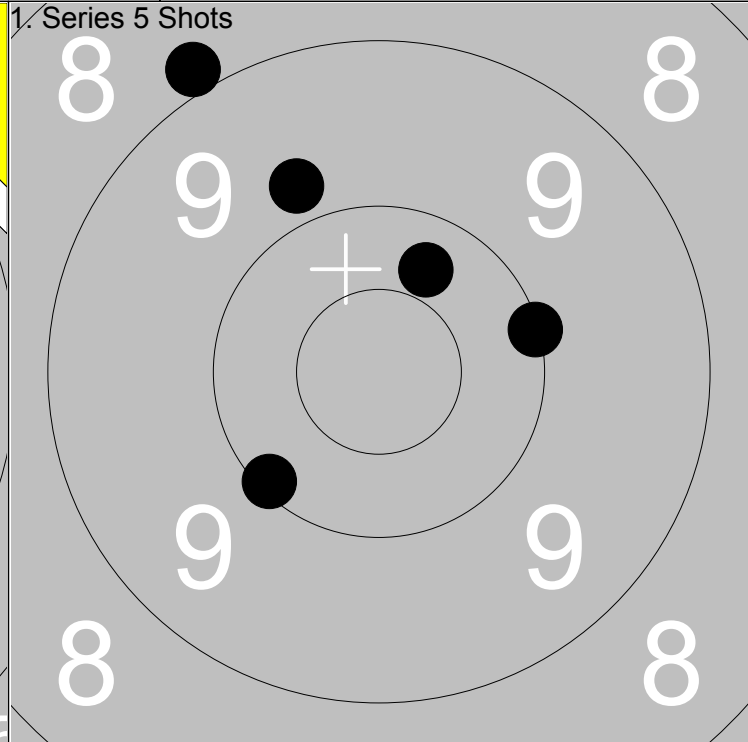
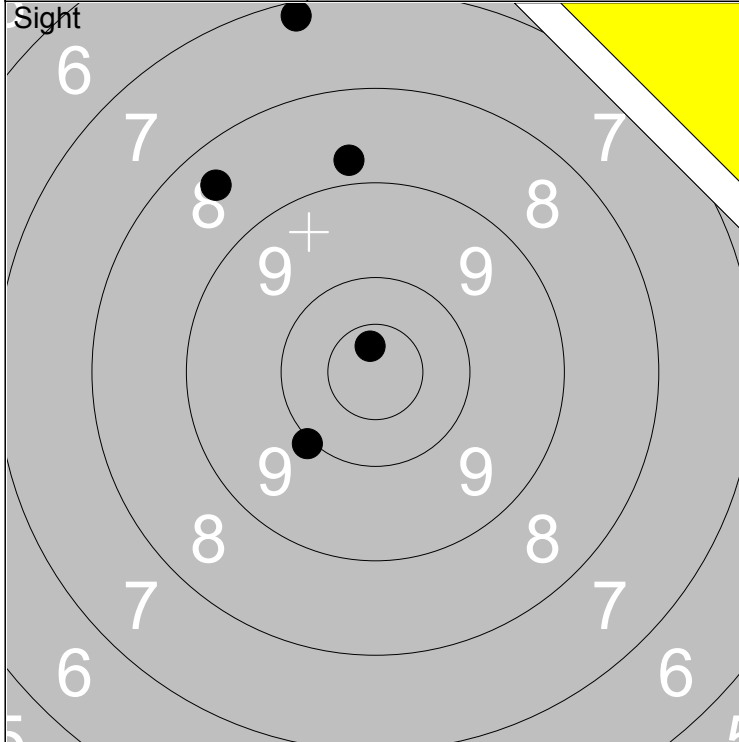

1: 7.2 ↑	Series	43.0
2: 8.8 ↑		
3: *10.7 ↑	Total	0.0
4: 8.4 ↖		
5: 10.0 ↙		

1: 10.3 ↗	Series	47.0
2: 10.1 ↙		
3: 8.9 ↖	Total	47.0
4: 10.0 →		
5: 9.8 ↖		

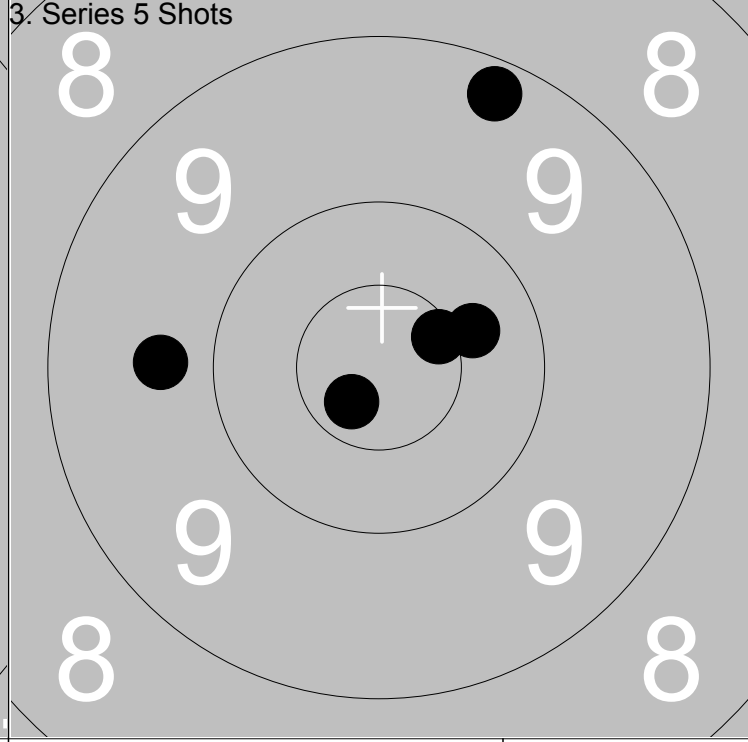
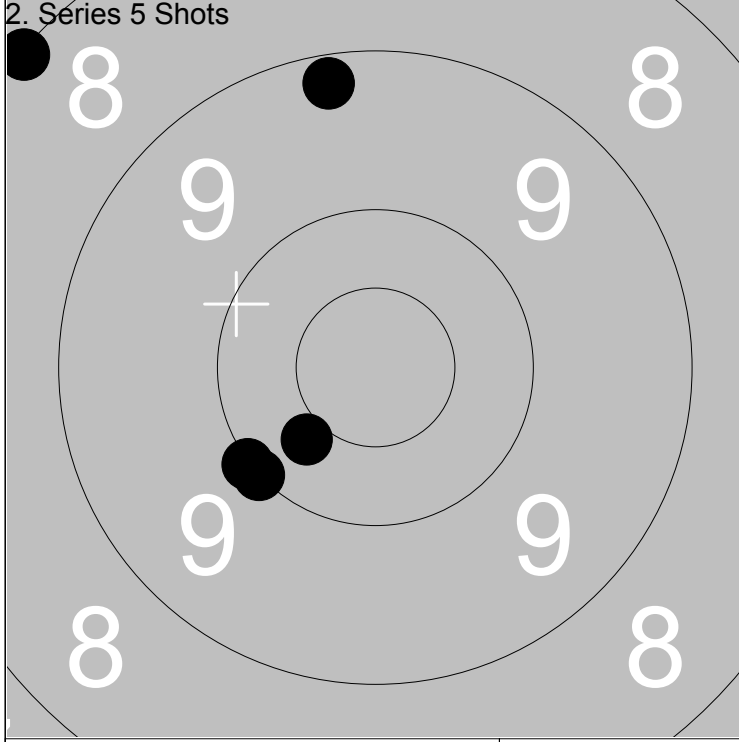

1: 8.1 ↖	Series	47.0
2: 9.2 ↑		
3: 10.0 ↙	Total	94.0
4: 10.4 ↙		
5: 10.0 ↙		

1: *10.7 ↙	Series	48.0
2: 9.7 ←		
3: 10.4 →	Total	142.0
4: *10.6 →		
5: 9.2 ↑		

<p>Sight</p>	<p>1: 9.6 ↑ 2: 9.7 ↖ 3: *10.6 ↓ 4: 9.1 ← 5: 9.2 ↘</p>	<p>1. Series 5 Shots</p>	<p>1: 8.9 ↓ 2: 9.6 → 3: 9.2 ↙ 4: 10.3 ← 5: 8.6 ↓</p>
Series 46.0		Series 44.0	
Total 0.0		Total 44.0	

<p>2. Series 5 Shots</p>	<p>1: 9.8 ↓ 2: *10.6 ↗ 3: 9.9 ← 4: *10.5 → 5: 9.3 ←</p>	<p>3. Series 5 Shots</p>	<p>1: 8.5 ↙ 2: 8.2 ↙ 3: 10.2 ↓ 4: 10.0 ← 5: 9.2 ↓</p>
Series 47.0		Series 45.0	
Total 91.0		Total 136.0	

<p>4. Series 10 Shots</p>	<p>1: *10.6 ← 2: 8.3 ↓ 3: 8.8 → 4: 7.8 ↓ 5: 8.8 ↘</p>	<p>4. Series 10 Shots</p>	<p>6: 9.6 ↓ 7: 6.8 → 8: 9.4 → 9: 8.9 → 10: 5.9 →</p>
Series 41.0		Series 37.0	
Total 177.0		Total 214.0	

<p>Sight</p>	<p>1. Series 5 Shots</p>	<p>1: 9.2 ↖ 2: 8.5 ↓ 3: 7.9 ↗ 4: *10.5 ↗ 5: 10.0 ↑</p>	<p>1: 8.4 ↘ 2: *10.6 ↖ 3: 10.3 ↖ 4: 9.8 ↑ 5: 8.1 ↘</p>						
<table border="1" style="width:100%; border-collapse: collapse;"> <tr><td style="width:50%;">Series</td><td style="width:50%;">44.0</td></tr> <tr><td>Total</td><td>0.0</td></tr> </table>	Series	44.0	Total	0.0	<table border="1" style="width:100%; border-collapse: collapse;"> <tr><td style="width:50%;">Series</td><td style="width:50%;">45.0</td></tr> <tr><td>Total</td><td>45.0</td></tr> </table>	Series	45.0	Total	45.0
Series	44.0								
Total	0.0								
Series	45.0								
Total	45.0								

<p>2. Series 5 Shots</p>	<p>3. Series 5 Shots</p>	<p>1: *10.5 ↘ 2: 10.2 ↓ 3: 9.1 ← 4: 9.2 ↘ 5: 10.3 ↖</p>	<p>1: 9.7 ↓ 2: 9.8 ↖ 3: *10.6 ↖ 4: 9.6 ↗ 5: 9.7 ↘</p>						
<table border="1" style="width:100%; border-collapse: collapse;"> <tr><td style="width:50%;">Series</td><td style="width:50%;">48.0</td></tr> <tr><td>Total</td><td>93.0</td></tr> </table>	Series	48.0	Total	93.0	<table border="1" style="width:100%; border-collapse: collapse;"> <tr><td style="width:50%;">Series</td><td style="width:50%;">46.0</td></tr> <tr><td>Total</td><td>139.0</td></tr> </table>	Series	46.0	Total	139.0
Series	48.0								
Total	93.0								
Series	46.0								
Total	139.0								

<p>4. Series 10 Shots</p>	<p>4. Series 10 Shots</p>	<p>1: 10.3 ↖ 2: 9.6 ↘ 3: 9.2 ↖ 4: 9.7 ↓ 5: 8.3 ↓</p>	<p>6: 9.6 → 7: 10.0 ↓ 8: 9.9 ↗ 9: 7.8 ↓ 10: 8.7 ↓</p>						
<table border="1" style="width:100%; border-collapse: collapse;"> <tr><td style="width:50%;">Series</td><td style="width:50%;">45.0</td></tr> <tr><td>Total</td><td>184.0</td></tr> </table>	Series	45.0	Total	184.0	<table border="1" style="width:100%; border-collapse: collapse;"> <tr><td style="width:50%;">Series</td><td style="width:50%;">43.0</td></tr> <tr><td>Total</td><td>227.0</td></tr> </table>	Series	43.0	Total	227.0
Series	45.0								
Total	184.0								
Series	43.0								
Total	227.0								

Relay 1	Lane 21	Leif Sigfridsson		
-------------------	-------------------	-------------------------	--	--

300m	Ramselefors	E	Vb
------	-------------	---	----

06.07.2014	Tavelträffen 2014	Ramselefors SKF
------------	-------------------	-----------------

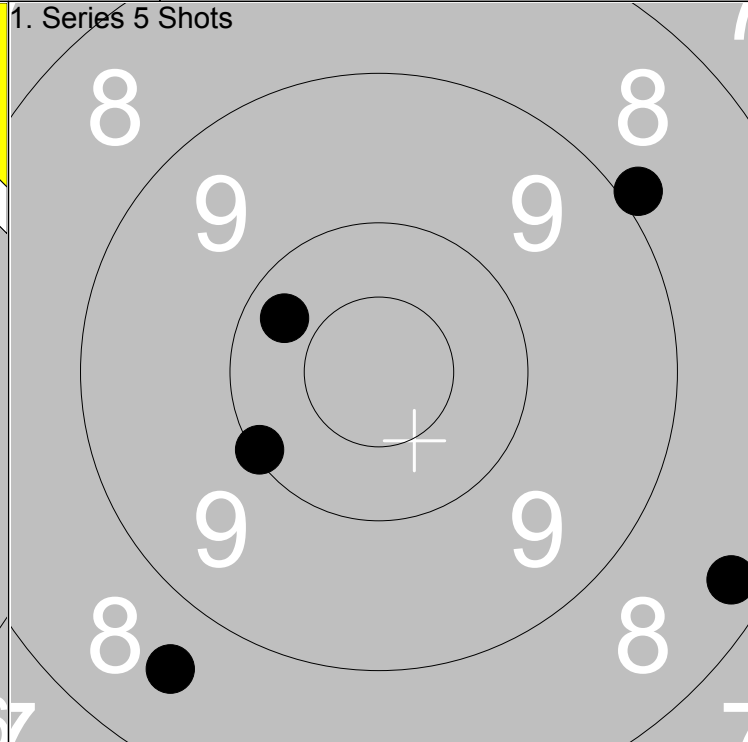
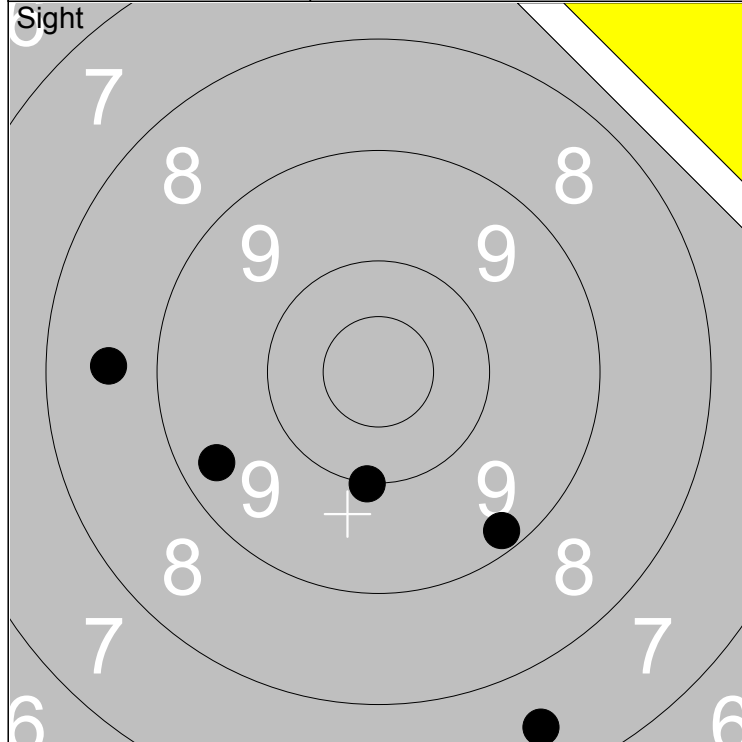

1: 7.5 ↓	Series	43.0
2: 10.0 ↓		
3: 9.2 ↓	Total	0.0
4: 9.4 ←		
5: 8.6 ←		

1: 10.3 ↖	Series	44.0
2: 8.3 →		
3: 10.1 ↙	Total	44.0
4: 8.6 ↘		
5: 8.9 ↗		

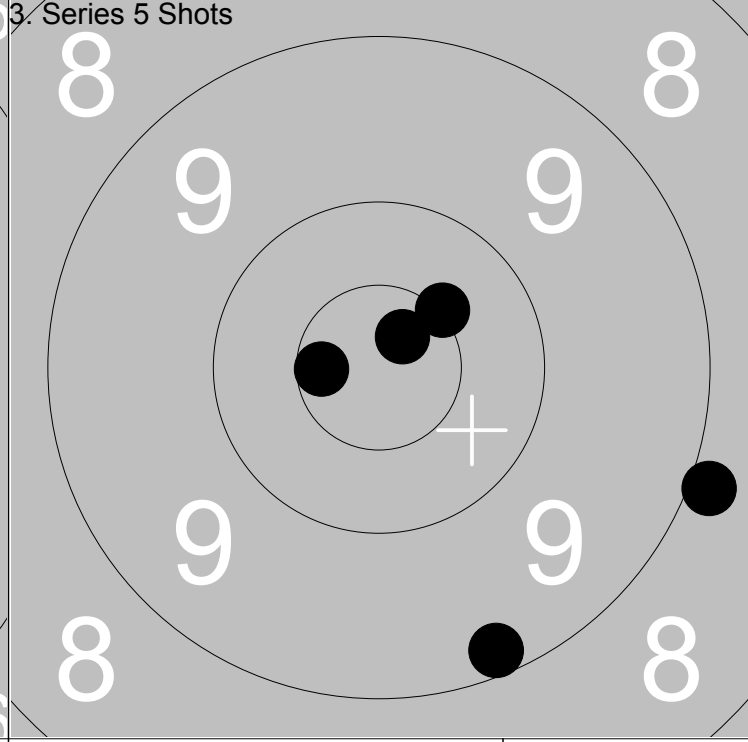
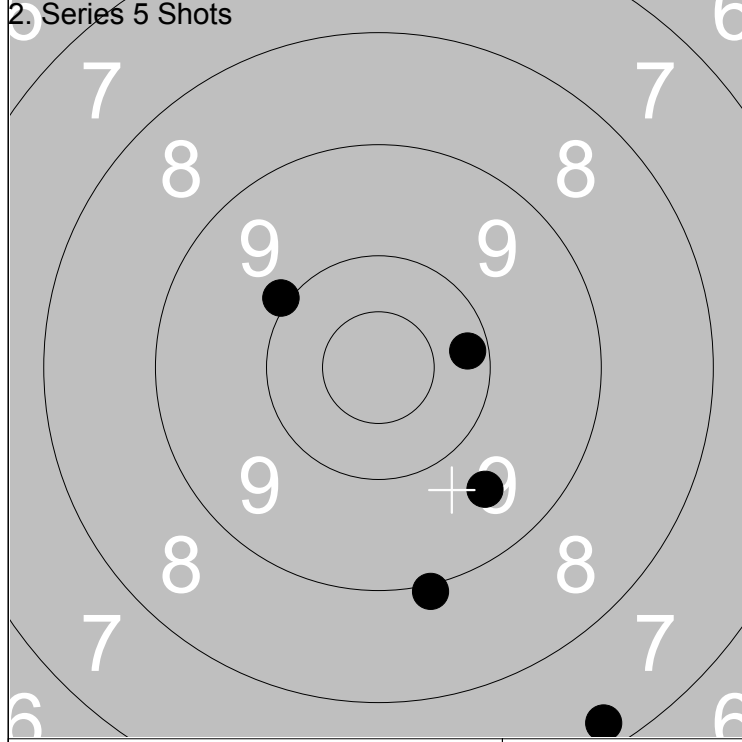

1: 10.0 ↗	Series	45.0
2: 9.6 ↓		
3: 9.0 ↓	Total	89.0
4: 10.2 →		
5: 7.3 ↓		

1: *10.6 ↙	Series	47.0
2: 9.2 ↓		
3: 8.9 →	Total	136.0
4: *10.7 ↗		
5: *10.5 ↗		

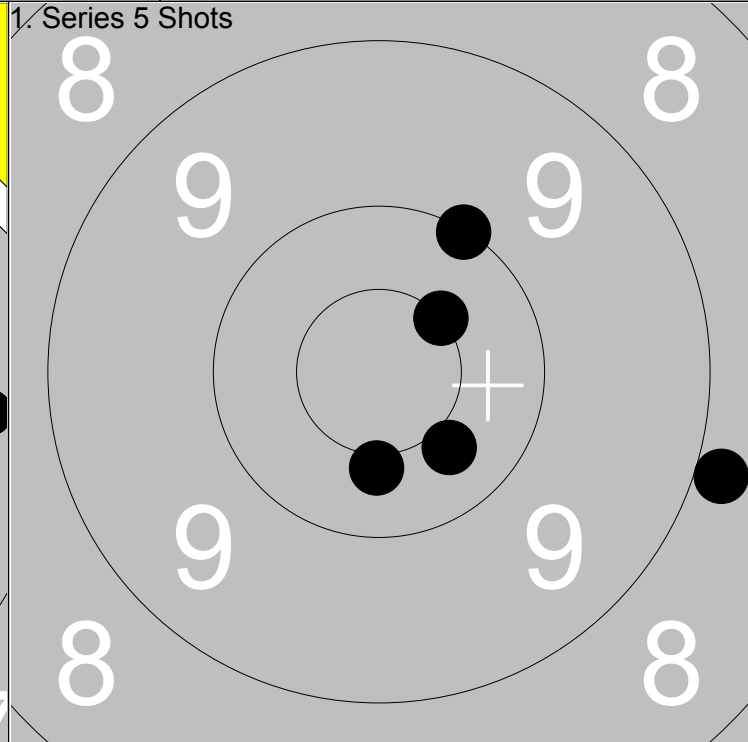
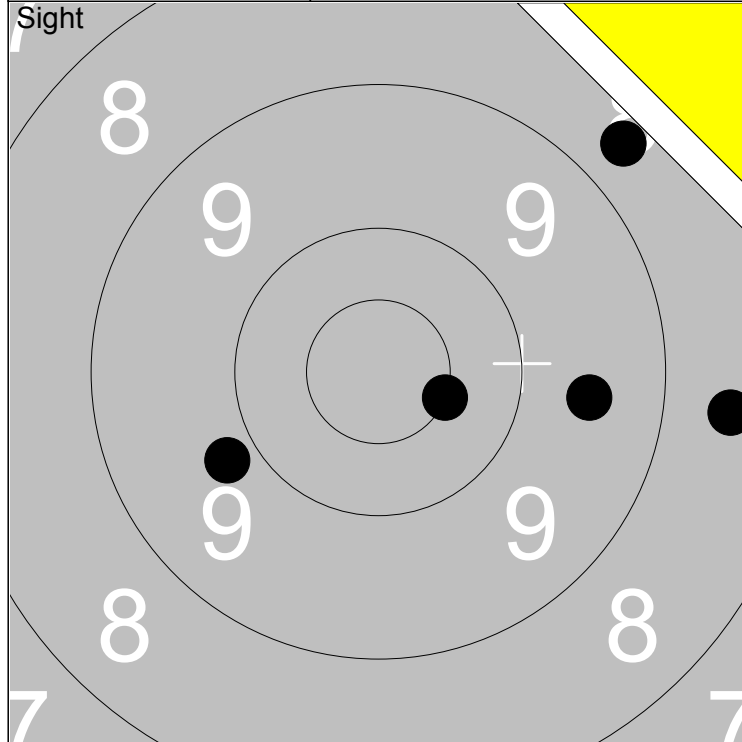

1: 9.6 →	Series	44.0
2: *10.5 →		
3: 8.6 →	Total	0.0
4: 8.7 ↗		
5: 9.8 ↙		

1: 10.0 ↗	Series	48.0
2: *10.5 ↗		
3: 10.4 ↓	Total	48.0
4: 8.9 →		
5: 10.4 ↘		

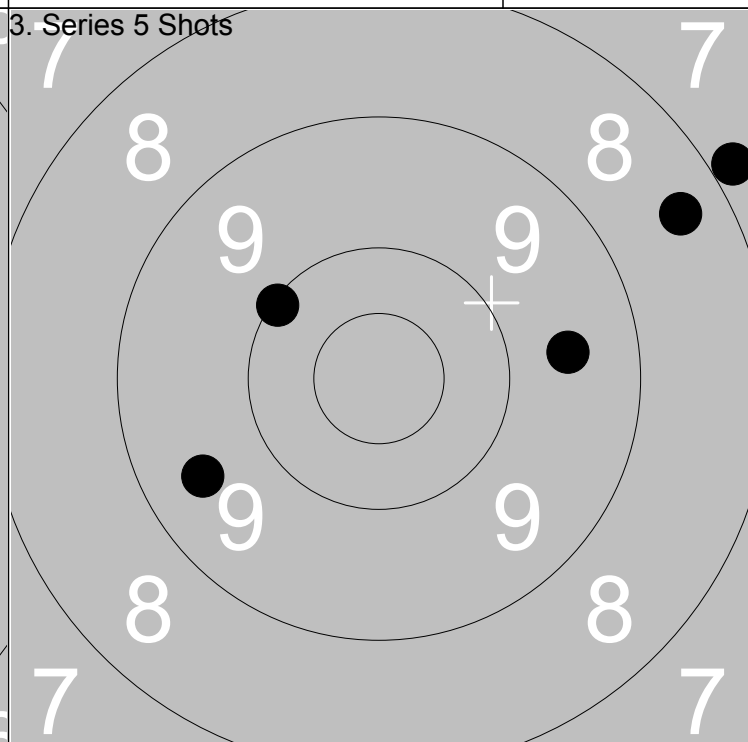
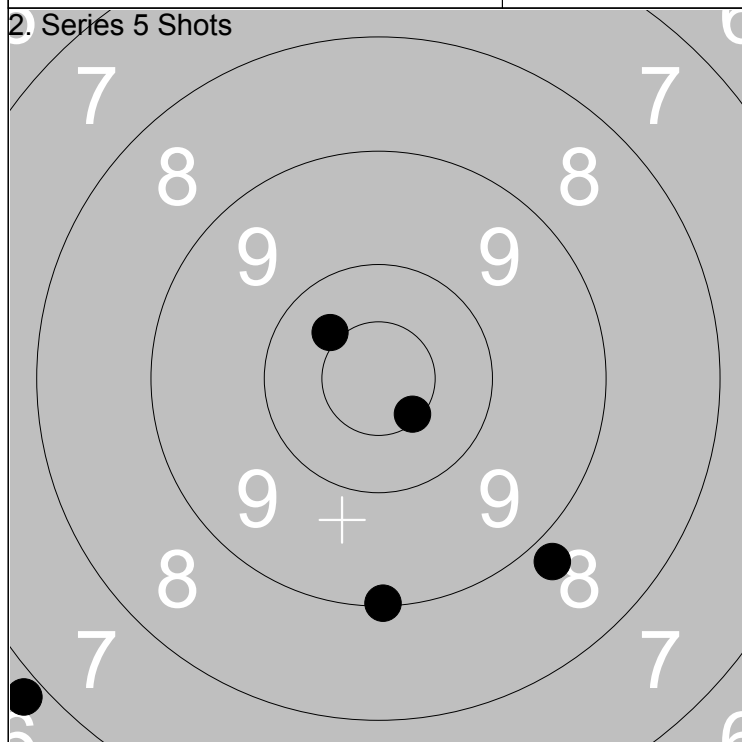

1: 9.1 ↓	Series	43.0
2: 8.8 ↘		
3: *10.6 ↘	Total	91.0
4: 10.4 ↗		
5: 6.8 ↙		

1: 9.5 ↙	Series	43.0
2: 10.1 ↖		
3: 8.4 ↗	Total	134.0
4: 9.6 →		
5: 7.9 ↗		

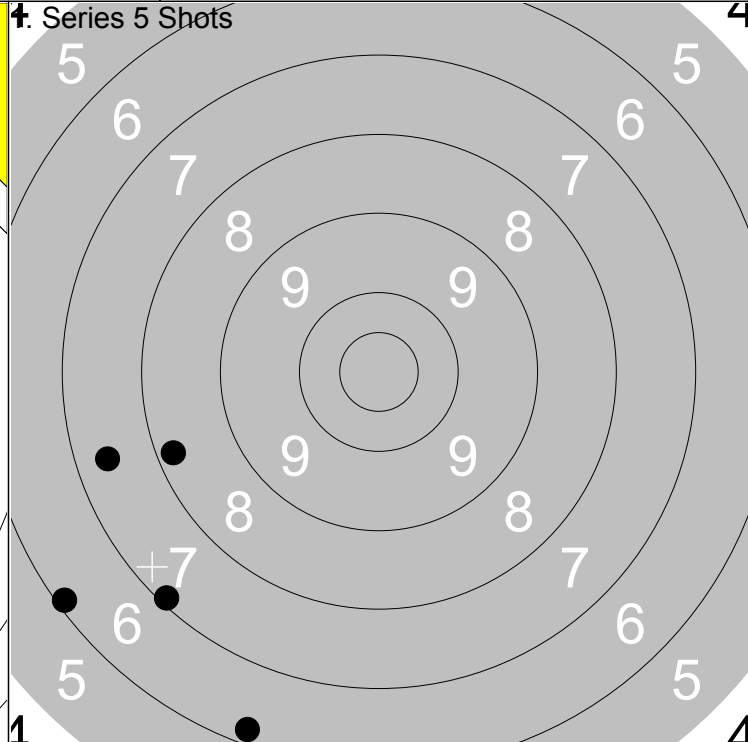
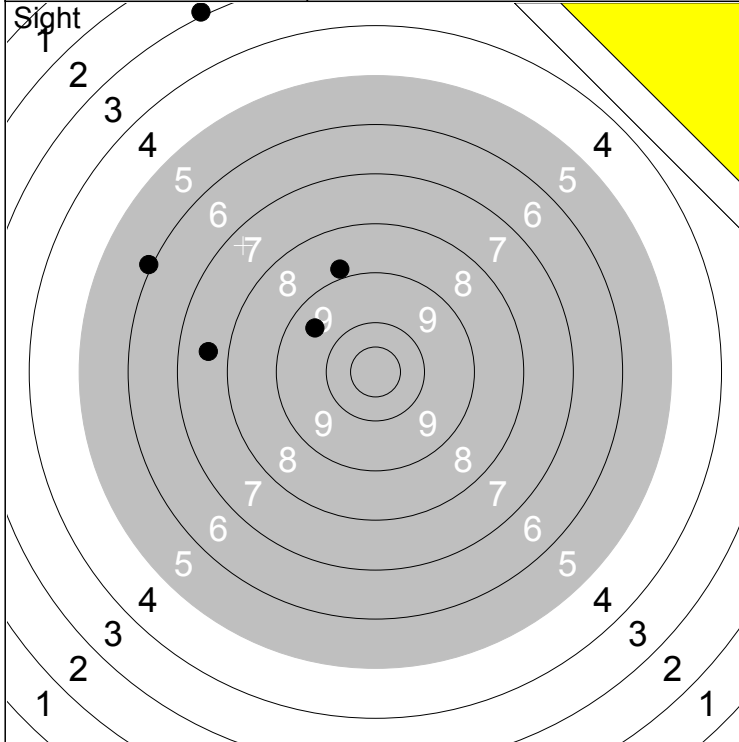

1: 2.9 ↗	Series 32.0
2: 6.0 ↖	
3: 9.5 ↗	
4: 8.8 ↗	
5: 7.6 ←	
Total 0.0	

1: 6.1 ↖	Series 34.0
2: 6.2 ↓	
3: 7.4 ←	
4: 7.1 ↖	
5: 8.2 ←	
Total 34.0	

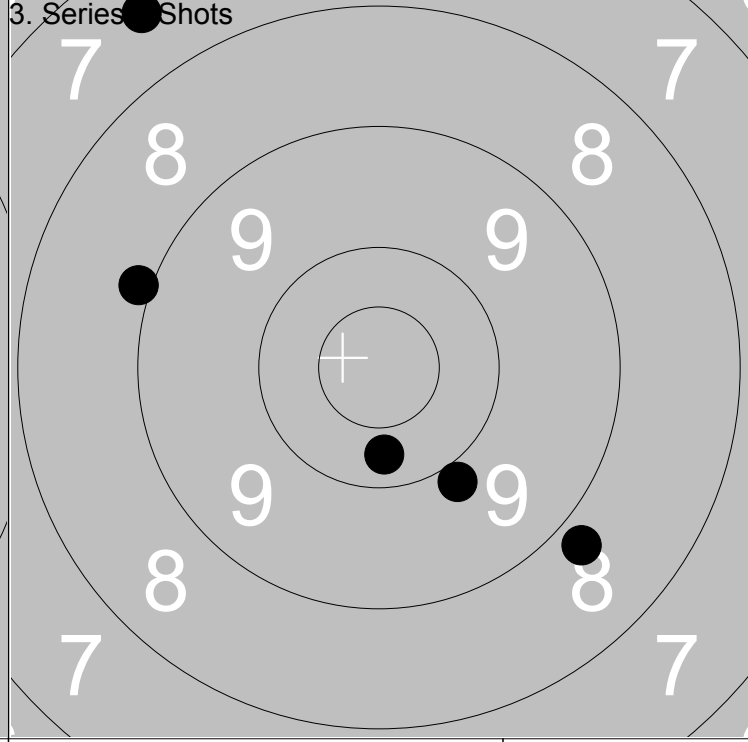
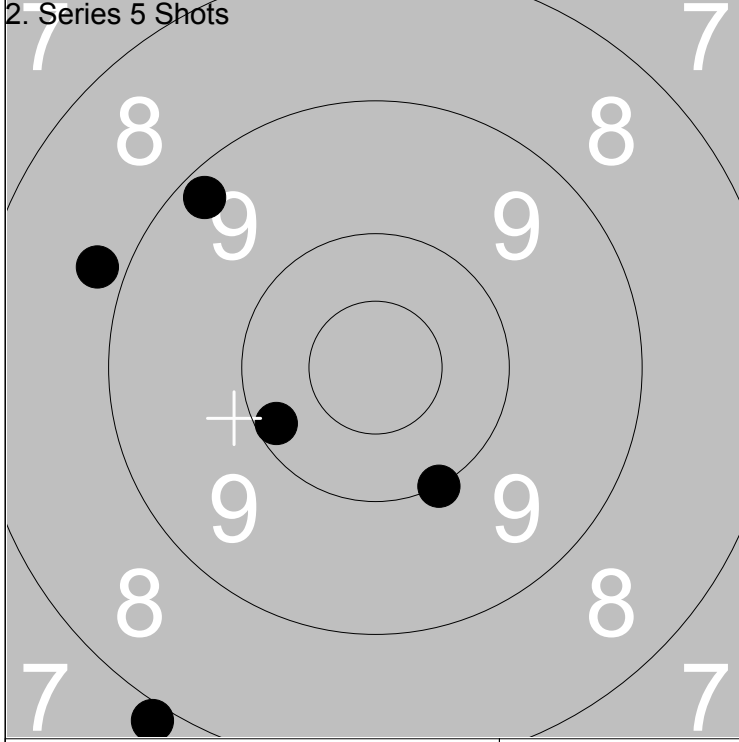

1: 10.0 ↓	Series 44.0
2: 7.9 ↓	
3: 8.8 ←	
4: 10.2 ←	
5: 9.2 ↗	
Total 78.0	

1: 8.8 ↓	Series 42.0
2: 9.9 ↓	
3: 7.5 ↗	
4: 10.3 ↓	
5: 8.9 ←	
Total 120.0	

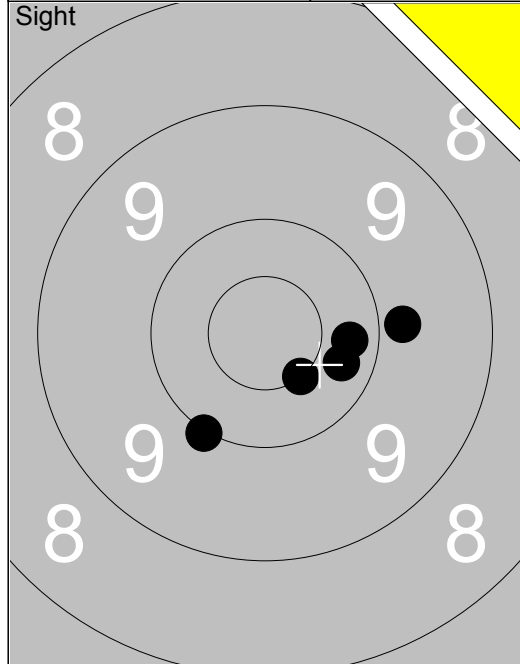

1:	10.3 →
2:	9.8 →
3:	10.0 ↙
4:	10.3 →
5:	*10.5 ↘
Series 49.0	
Total 0.0	

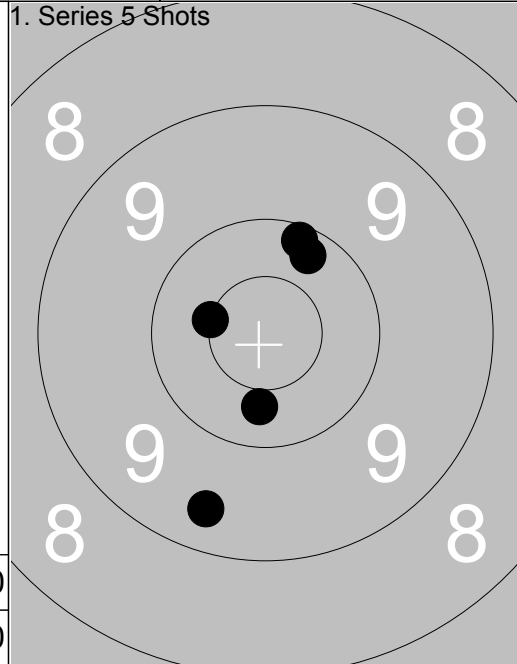

1:	9.4 ↙
2:	10.2 ↗
3:	*10.5 ↖
4:	10.4 ↘
5:	10.1 ↗
Series 49.0	
Total 49.0	

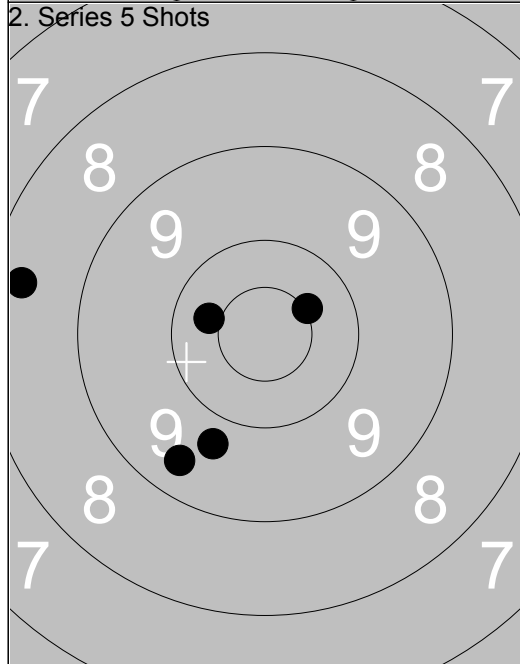

1:	10.4 ↖
2:	9.4 ↙
3:	9.7 ↙
4:	*10.5 ↗
5:	8.4 ←
Series 46.0	
Total 95.0	

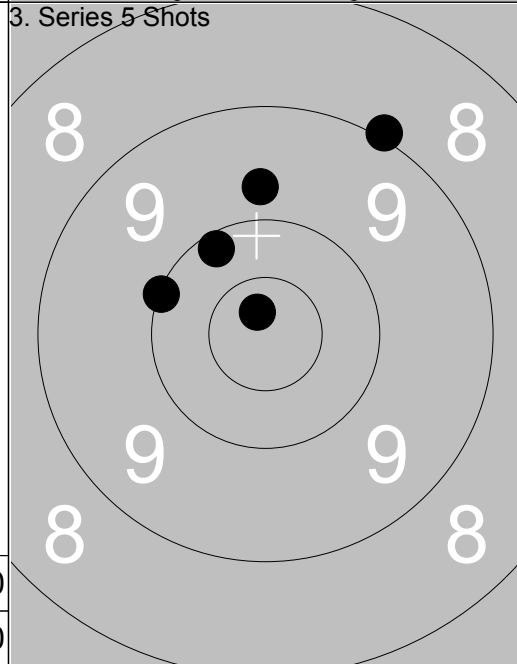

1:	10.1 ↖
2:	10.0 ↖
3:	*10.8 ↖
4:	9.0 ↗
5:	9.7 ↗
Series 48.0	
Total 143.0	

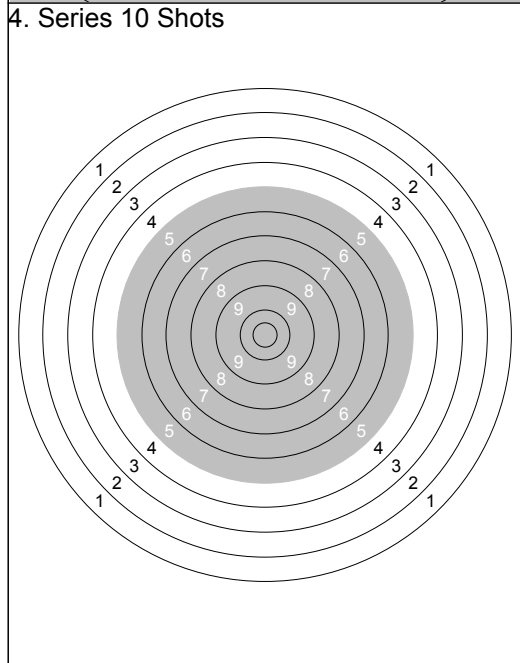

1:	0.0 ↖
Series 0.0	
Total 143.0	

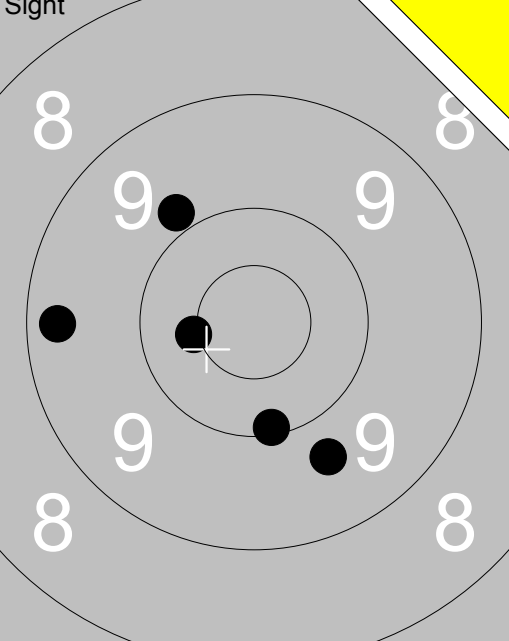
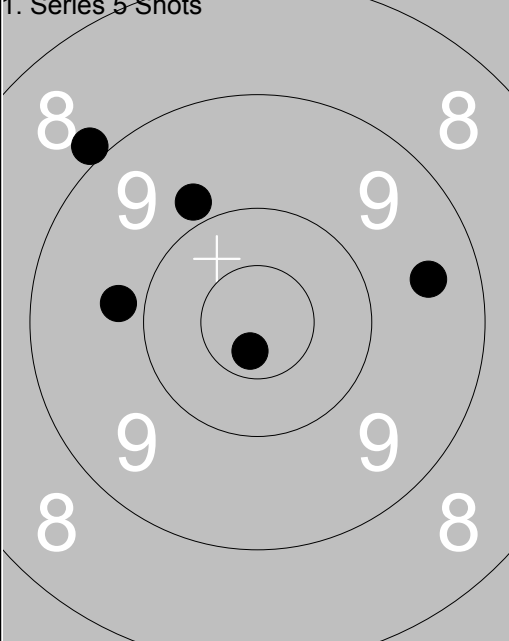
<p>Sight</p> 	<p>1: 9.7 ↘ 2: 10.1 ↓ 3: 9.3 ← 4: *10.4 ← 5: 9.8 ↗</p>	<p>1. Series 5 Shots</p> 	<p>1: 9.8 ↗ 2: 9.8 ← 3: 9.5 → 4: *10.7 ↓ 5: 8.9 ↗</p>
Series 47.0		Series 45.0	
Total 0.0		Total 45.0	

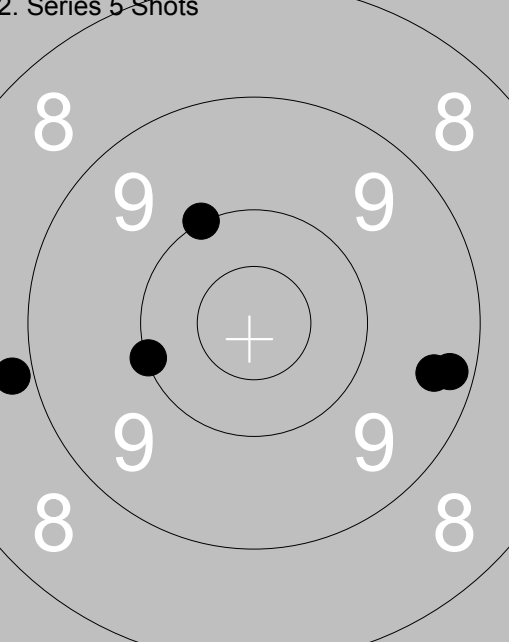
<p>2. Series 5 Shots</p> 	<p>1: 9.4 → 2: 8.8 ← 3: 9.3 → 4: 10.0 ← 5: 10.0 ↗</p>	<p>3. Series 5 Shots</p> 	<p>1: 10.1 → 2: 9.3 → 3: 9.7 → 4: 9.7 ↓ 5: *10.8 ↗</p>
Series 46.0		Series 47.0	
Total 91.0		Total 138.0	

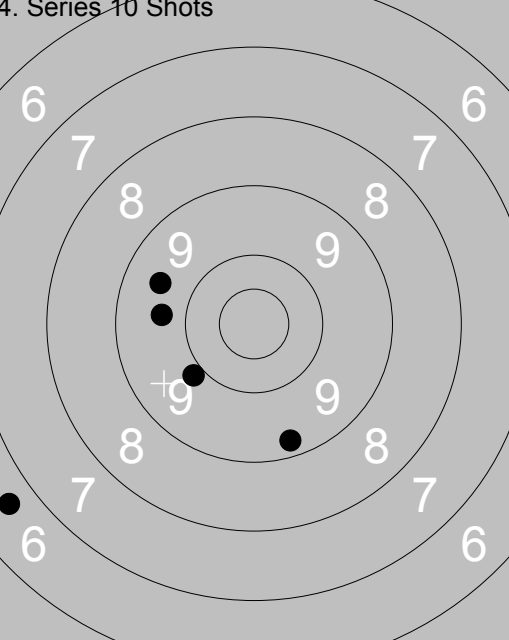
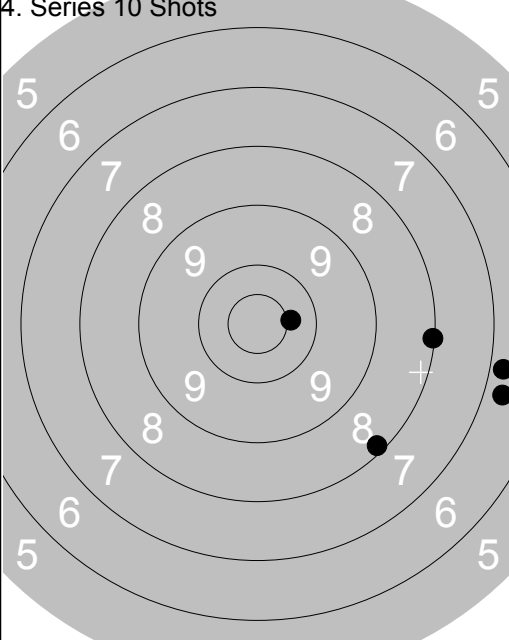
<p>4. Series 10 Shots</p> 	<p>1: 9.9 ↘ 2: 9.7 ← 3: 6.6 ↘ 4: 9.3 ↓ 5: 9.5 ←</p>	<p>4. Series 10 Shots</p> 	<p>6: 8.2 ↘ 7: 6.7 → 8: 8.1 → 9: *10.4 → 10: 6.8 →</p>
Series 42.0		Series 38.0	
Total 180.0		Total 218.0	

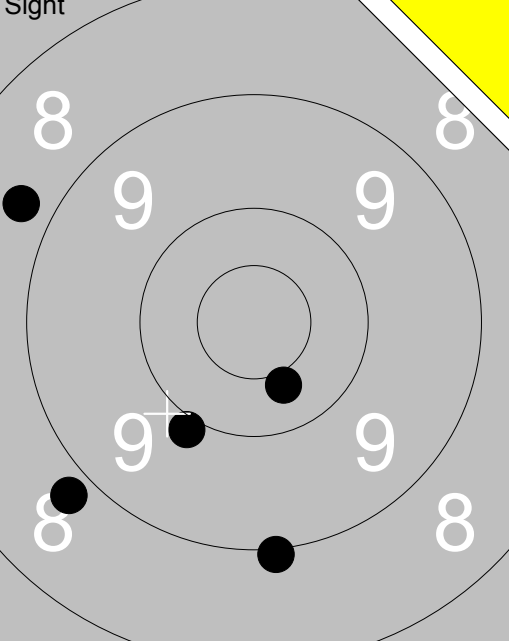
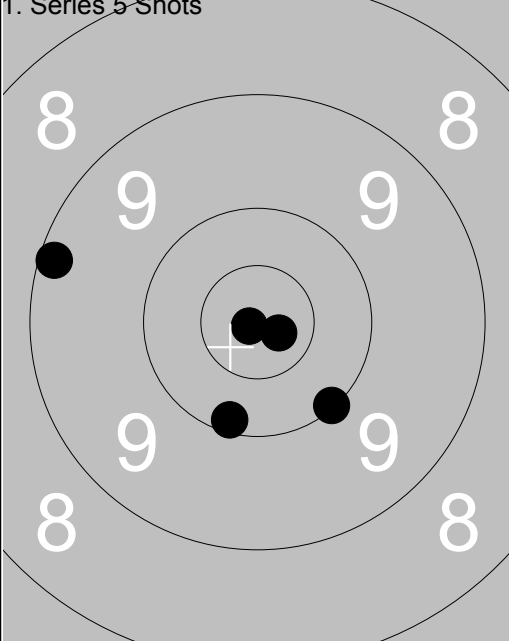
<p>Sight</p> 	<p>1: 10.4 ↓ 2: 9.9 ↓ 3: 8.8 ↙ 4: 8.7 ↖ 5: 9.0 ↓</p>	<p>1. Series 5 Shots</p> 	<p>1: 9.2 ↖ 2: *10.8 ↗ 3: 10.0 ↓ 4: 10.1 ↓ 5: *10.9 ↙</p>
Series 44.0		Series 49.0	
Total 0.0		Total 49.0	

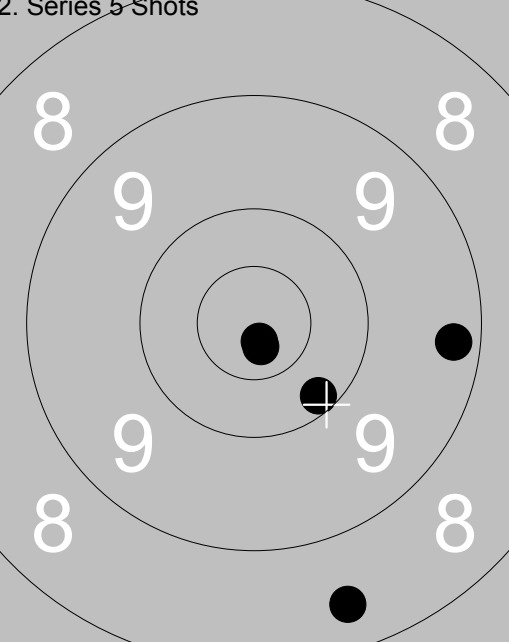
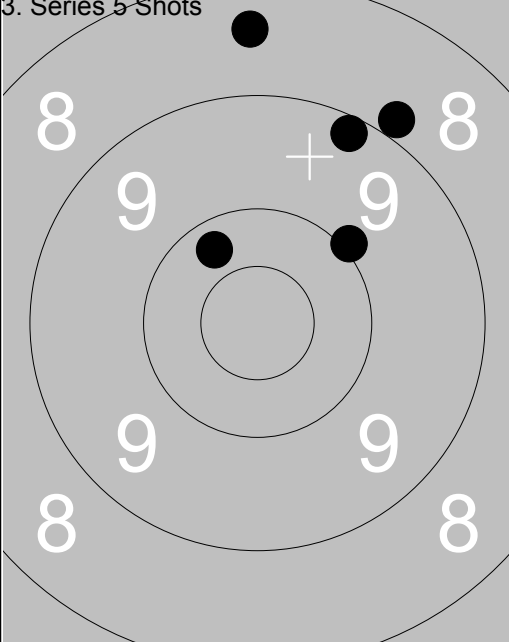
<p>2. Series 5 Shots</p> 	<p>1: *10.7 ↓ 2: 9.3 → 3: *10.8 ↓ 4: 8.4 ↓ 5: 10.2 ↓</p>	<p>3. Series 5 Shots</p> 	<p>1: 9.2 ↗ 2: 10.0 ↗ 3: 10.3 ↖ 4: 8.4 ↑ 5: 8.9 ↗</p>
Series 47.0		Series 45.0	
Total 96.0		Total 141.0	

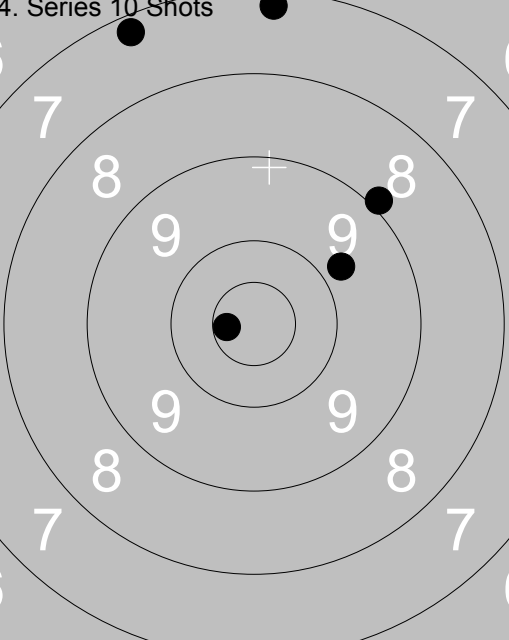
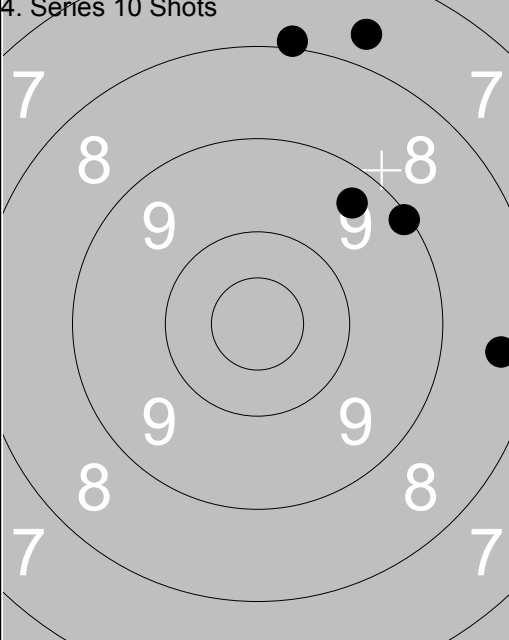
<p>4. Series 10 Shots</p> 	<p>1: 7.2 ↖ 2: *10.6 ↖ 3: 9.8 ↗ 4: 8.9 ↗ 5: 7.2 ↑</p>	<p>4. Series 10 Shots</p> 	<p>6: 7.7 ↖ 7: 7.9 ↑ 8: 8.4 → 9: 9.4 ↗ 10: 9.1 ↗</p>
Series 41.0		Series 40.0	
Total 182.0		Total 222.0	

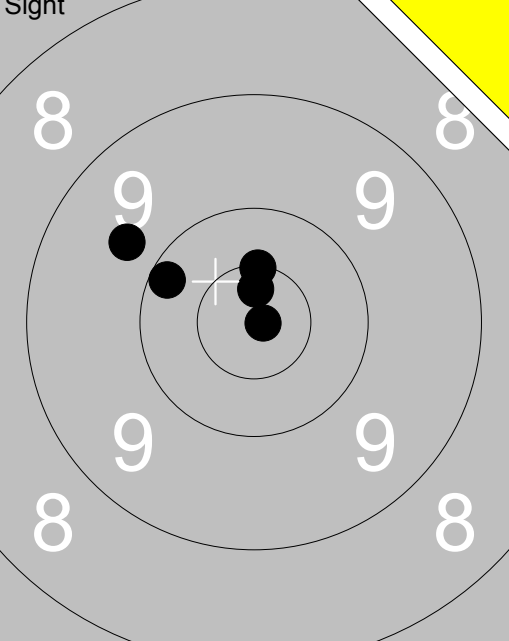
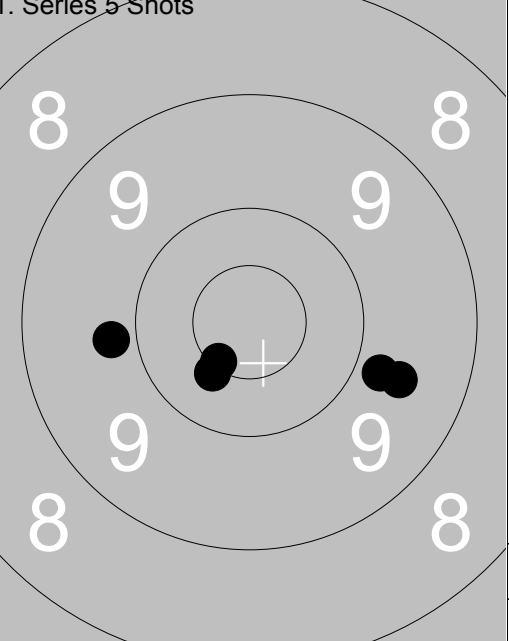
<p>Sight</p> 	<p>1: 9.7 ↙ 2: 10.2 ↙ 3: *10.5 ↑ 4: *10.9 → 5: *10.7 ↑</p>	<p>1. Series 5 Shots</p> 	<p>1: 9.6 → 2: 9.8 → 3: 9.8 ← 4: *10.4 ↘ 5: *10.5 ↘</p>								
<table border="1" style="float: right; border-collapse: collapse;"> <tr><td>Series</td><td>49.0</td></tr> <tr><td>Total</td><td>0.0</td></tr> </table>		Series	49.0	Total	0.0	<table border="1" style="float: right; border-collapse: collapse;"> <tr><td>Series</td><td>47.0</td></tr> <tr><td>Total</td><td>47.0</td></tr> </table>		Series	47.0	Total	47.0
Series	49.0										
Total	0.0										
Series	47.0										
Total	47.0										

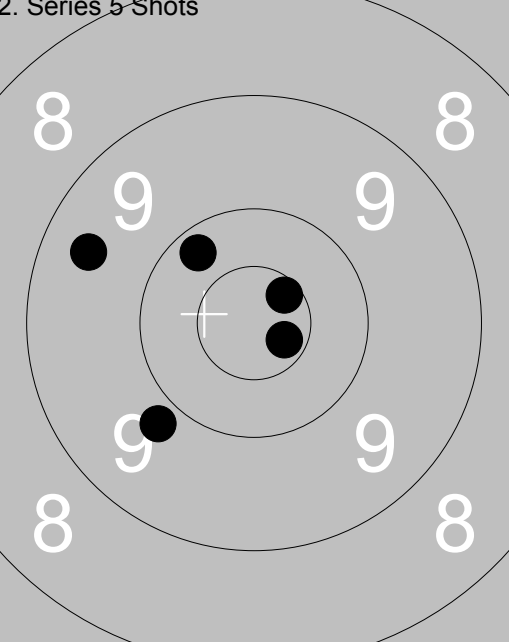
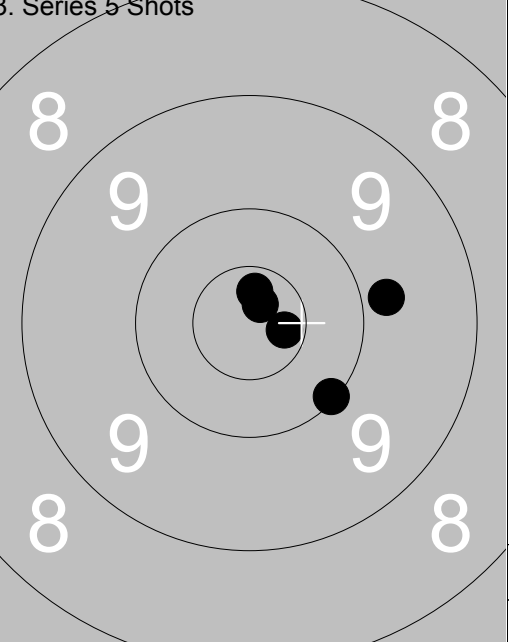
<p>2. Series 5 Shots</p> 	<p>1: 9.4 ↙ 2: 10.2 ↙ 3: *10.6 ↗ 4: *10.7 → 5: 9.8 ↘</p>	<p>3. Series 5 Shots</p> 	<p>1: 10.1 ↘ 2: *10.7 ↑ 3: 9.8 → 4: *10.7 → 5: *10.8 ↗</p>								
<table border="1" style="float: right; border-collapse: collapse;"> <tr><td>Series</td><td>48.0</td></tr> <tr><td>Total</td><td>95.0</td></tr> </table>		Series	48.0	Total	95.0	<table border="1" style="float: right; border-collapse: collapse;"> <tr><td>Series</td><td>49.0</td></tr> <tr><td>Total</td><td>144.0</td></tr> </table>		Series	49.0	Total	144.0
Series	48.0										
Total	95.0										
Series	49.0										
Total	144.0										

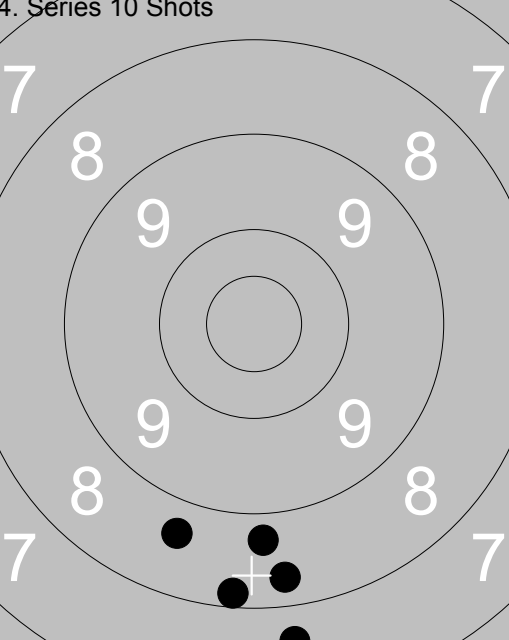
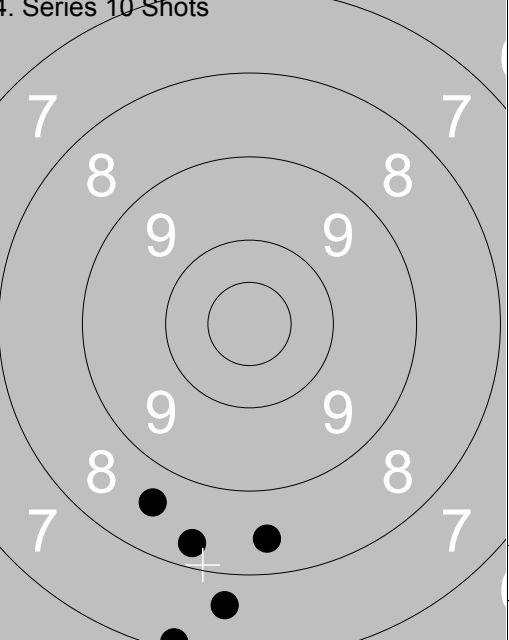
<p>4. Series 10 Shots</p> 	<p>1: 8.7 ↓ 2: 8.3 ↓ 3: 8.7 ↓ 4: 8.2 ↓ 5: 7.6 ↓</p>	<p>4. Series 10 Shots</p> 	<p>6: 7.1 ↓ 7: 7.7 ↓ 8: 8.6 ↓ 9: 8.3 ↓ 10: 8.5 ↓</p>								
<table border="1" style="float: right; border-collapse: collapse;"> <tr><td>Series</td><td>39.0</td></tr> <tr><td>Total</td><td>183.0</td></tr> </table>		Series	39.0	Total	183.0	<table border="1" style="float: right; border-collapse: collapse;"> <tr><td>Series</td><td>38.0</td></tr> <tr><td>Total</td><td>221.0</td></tr> </table>		Series	38.0	Total	221.0
Series	39.0										
Total	183.0										
Series	38.0										
Total	221.0										

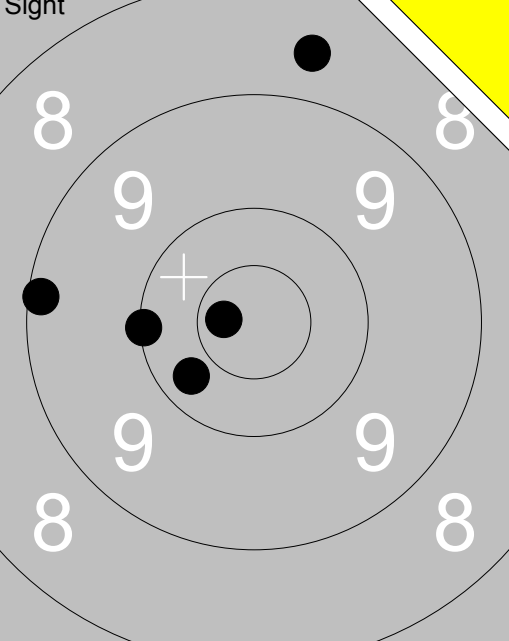
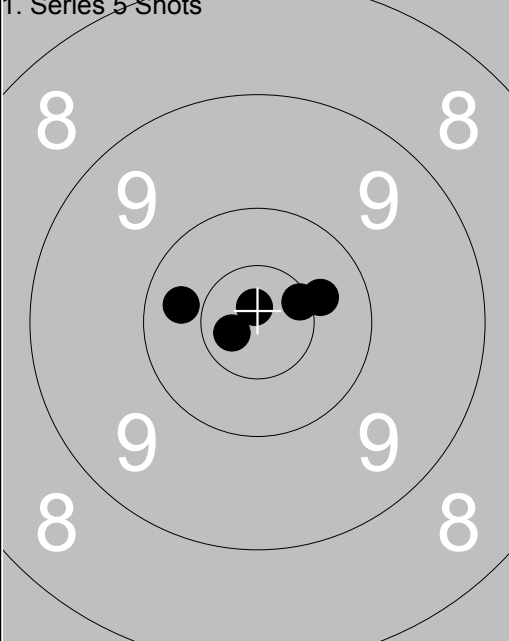
<p>Sight</p>  <p>1: 8.6 ↑ 2: 9.1 ← 3: 10.0 ← 4: *10.7 ↖ 5: 10.3 ↙</p> <table border="1" style="width:100%; border-collapse: collapse;"> <tr><td style="text-align:right;">Series</td><td style="text-align:left;">47.0</td></tr> <tr><td style="text-align:right;">Total</td><td style="text-align:left;">0.0</td></tr> </table>	Series	47.0	Total	0.0	<p>1. Series 5 Shots</p>  <p>1: *10.8 ↖ 2: *10.6 ↗ 3: 10.3 ← 4: 10.4 → 5: *10.7 ↖</p> <table border="1" style="width:100%; border-collapse: collapse;"> <tr><td style="text-align:right;">Series</td><td style="text-align:left;">50.0</td></tr> <tr><td style="text-align:right;">Total</td><td style="text-align:left;">50.0</td></tr> </table>	Series	50.0	Total	50.0	
Series	47.0									
Total	0.0									
Series	50.0									
Total	50.0									

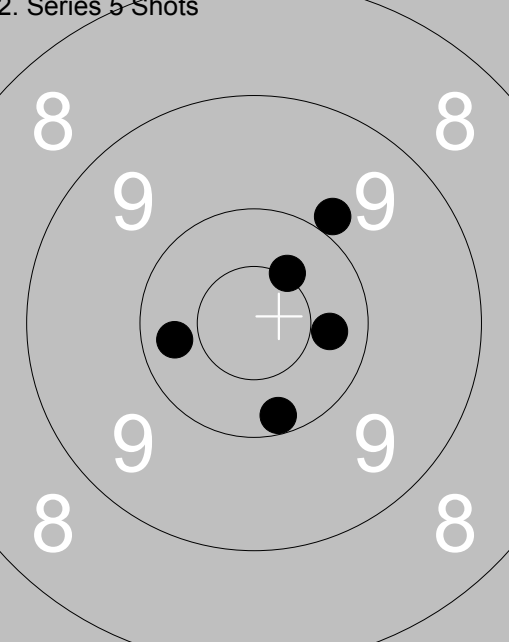
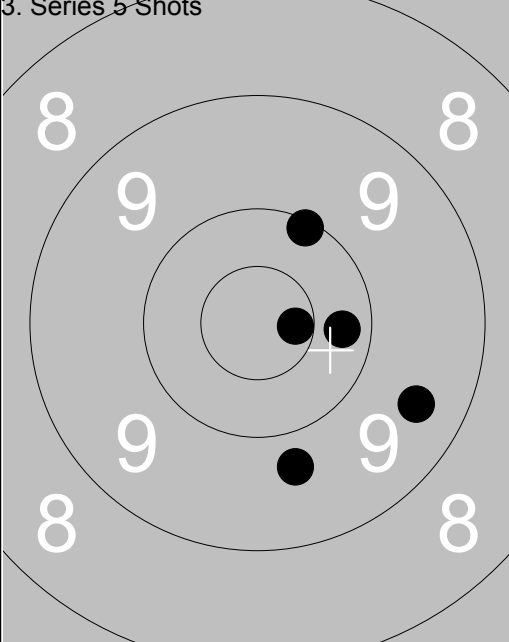
<p>2. Series 5 Shots</p>  <p>1: 10.3 ← 2: 9.9 ↗ 3: 10.2 ↓ 4: *10.5 ↗ 5: 10.3 →</p> <table border="1" style="width:100%; border-collapse: collapse;"> <tr><td style="text-align:right;">Series</td><td style="text-align:left;">49.0</td></tr> <tr><td style="text-align:right;">Total</td><td style="text-align:left;">99.0</td></tr> </table>	Series	49.0	Total	99.0	<p>3. Series 5 Shots</p>  <p>1: 10.3 → 2: *10.6 → 3: 10.1 ↗ 4: 9.5 → 5: 9.7 ↓</p> <table border="1" style="width:100%; border-collapse: collapse;"> <tr><td style="text-align:right;">Series</td><td style="text-align:left;">48.0</td></tr> <tr><td style="text-align:right;">Total</td><td style="text-align:left;">147.0</td></tr> </table>	Series	48.0	Total	147.0	
Series	49.0									
Total	99.0									
Series	48.0									
Total	147.0									

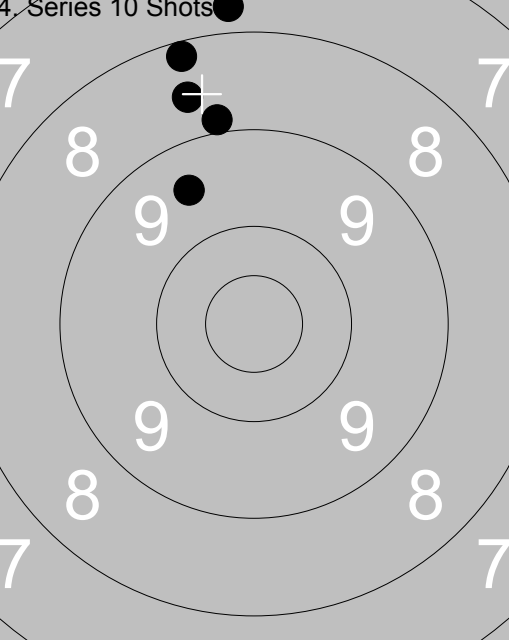
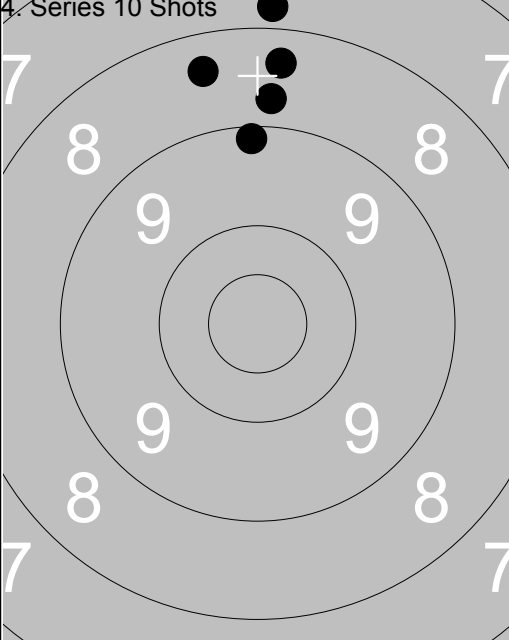
<p>4. Series 10 Shots</p>  <p>1: 7.8 ↑ 2: 8.2 ↑ 3: 8.6 ↑ 4: 8.9 ↑ 5: 9.5 ↖</p> <table border="1" style="width:100%; border-collapse: collapse;"> <tr><td style="text-align:right;">Series</td><td style="text-align:left;">40.0</td></tr> <tr><td style="text-align:right;">Total</td><td style="text-align:left;">187.0</td></tr> </table>	Series	40.0	Total	187.0	<p>4. Series 10 Shots</p>  <p>6: 7.8 ↑ 7: 8.4 ↑ 8: 9.1 ↑ 9: 8.4 ↑ 10: 8.7 ↑</p> <table border="1" style="width:100%; border-collapse: collapse;"> <tr><td style="text-align:right;">Series</td><td style="text-align:left;">40.0</td></tr> <tr><td style="text-align:right;">Total</td><td style="text-align:left;">227.0</td></tr> </table>	Series	40.0	Total	227.0	
Series	40.0									
Total	187.0									
Series	40.0									
Total	227.0									

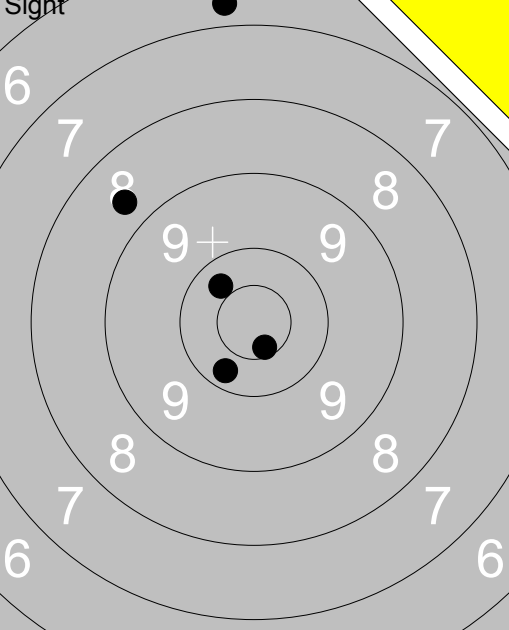
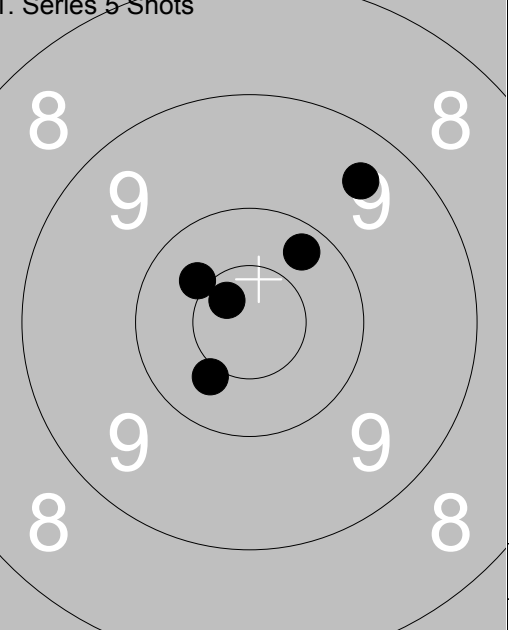
<p>Sight</p>  <p>Target diagram for Sight shot. Concentric circles labeled 6, 7, 8, 9. A yellow triangle is in the top right corner. Three black dots are clustered in the center, with a white crosshair.</p>	<p>1: 6.7 ↑</p> <p>2: 8.7 ↖</p> <p>3: 10.3 ↙</p> <p>4: 10.3 ↖</p> <p>5: *10.6 ↘</p>	<p>1. Series 5 Shots</p>  <p>Target diagram for 1. Series 5 Shots. Concentric circles labeled 8, 9. Five black dots are scattered in the center, with a white crosshair.</p>		<p>1: 10.4 ↖</p> <p>2: 10.2 ↗</p> <p>3: *10.7 ↖</p> <p>4: 9.5 ↗</p> <p>5: 10.4 ↙</p>
Series 44.0		Series 49.0		
Total 0.0		Total 49.0		

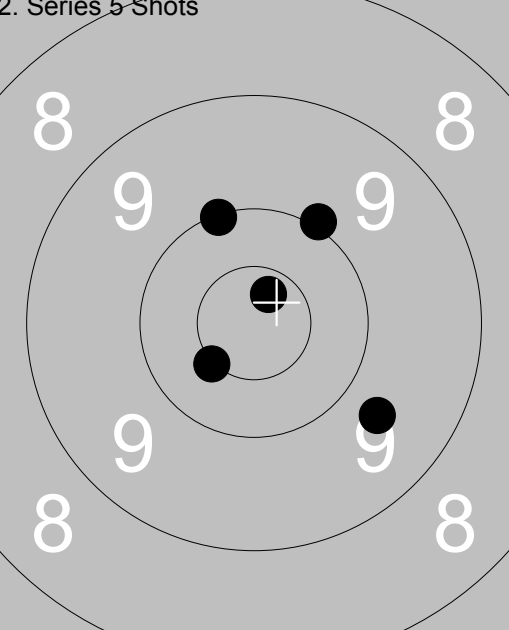
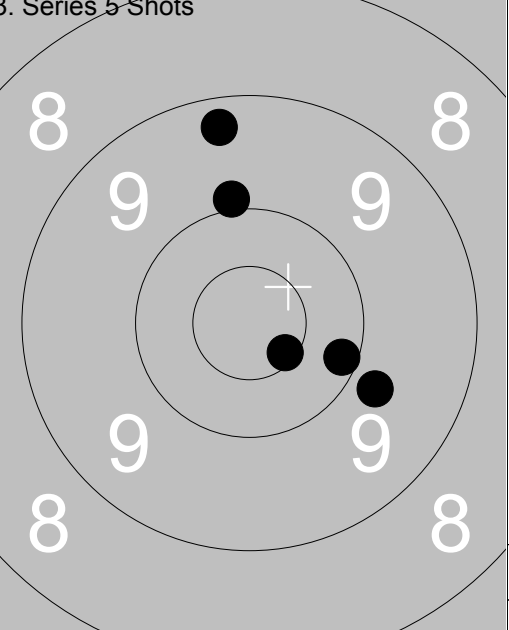
<p>2. Series 5 Shots</p>  <p>Target diagram for 2. Series 5 Shots. Concentric circles labeled 8, 9. Five black dots are scattered in the center, with a white crosshair.</p>	<p>1: *10.7 ↑</p> <p>2: *10.5 ↙</p> <p>3: 10.0 ↑</p> <p>4: 10.0 ↗</p> <p>5: 9.7 ↘</p>	<p>3. Series 5 Shots</p>  <p>Target diagram for 3. Series 5 Shots. Concentric circles labeled 8, 9. Five black dots are scattered in the center, with a white crosshair.</p>		<p>1: 9.3 ↑</p> <p>2: *10.6 ↘</p> <p>3: 9.9 ↑</p> <p>4: 9.8 ↘</p> <p>5: 10.1 →</p>
Series 49.0		Series 47.0		
Total 98.0		Total 145.0		

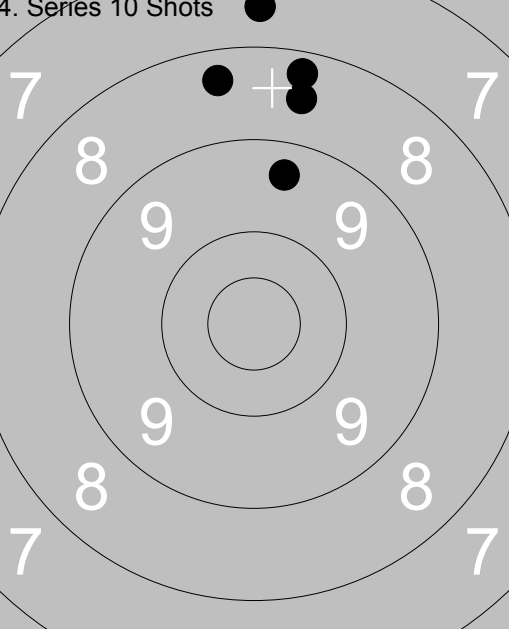
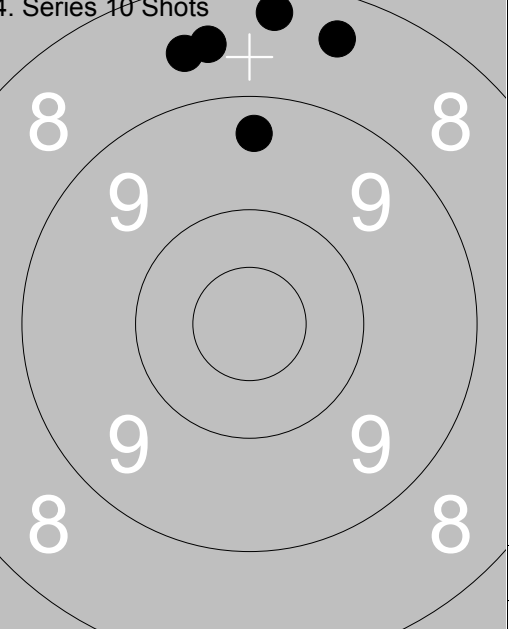
<p>4. Series 10 Shots</p>  <p>Target diagram for 4. Series 10 Shots. Concentric circles labeled 7, 8, 9. Ten black dots are scattered in the center, with a white crosshair.</p>	<p>1: 8.3 ↑</p> <p>2: 8.4 ↑</p> <p>3: 9.4 ↑</p> <p>4: 8.5 ↑</p> <p>5: 7.6 ↑</p>	<p>4. Series 10 Shots</p>  <p>Target diagram for 4. Series 10 Shots. Concentric circles labeled 8, 9. Ten black dots are scattered in the center, with a white crosshair.</p>		<p>6: 8.5 ↑</p> <p>7: 8.6 ↑</p> <p>8: 9.4 ↑</p> <p>9: 8.4 ↑</p> <p>10: 8.3 ↑</p>
Series 40.0		Series 41.0		
Total 185.0		Total 226.0		

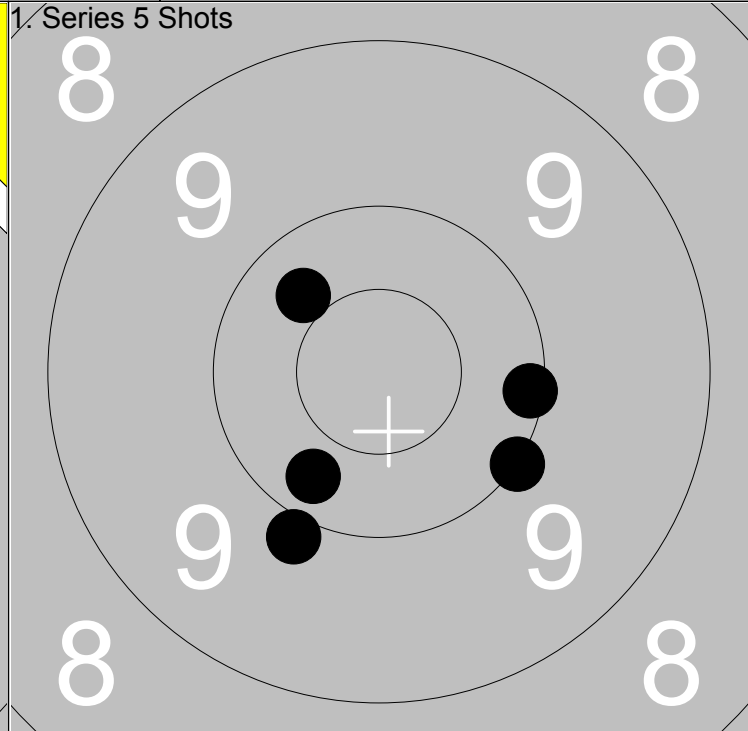
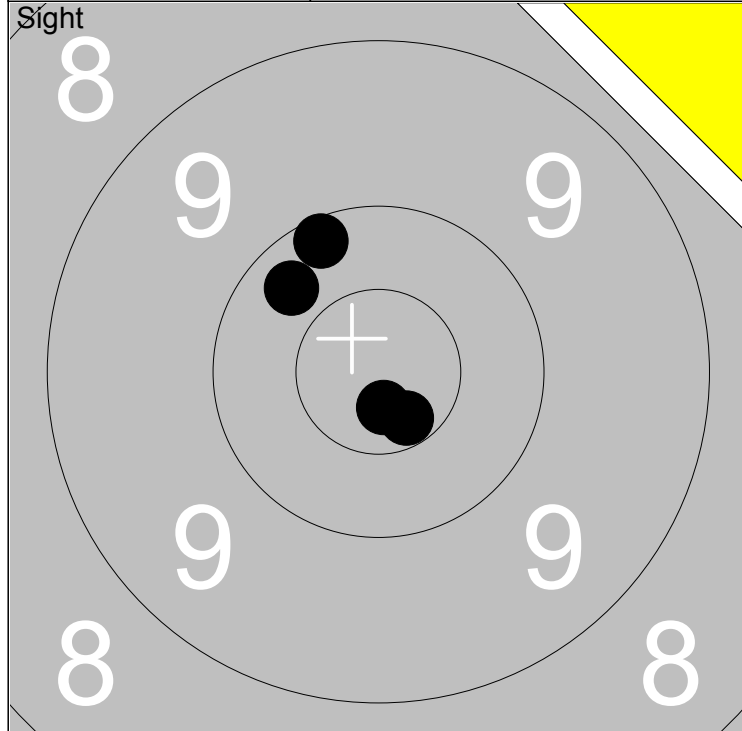

1: *10.6 ↘	Series	40.0
2: 10.3 ↗		
3: 10.2 ↗	Total	0.0
4: *10.7 ↘		

1: 10.3 ↙	Series	49.0
2: 10.1 →		
3: 10.0 ↘	Total	49.0
4: 9.9 ↙		
5: 10.3 ↖		

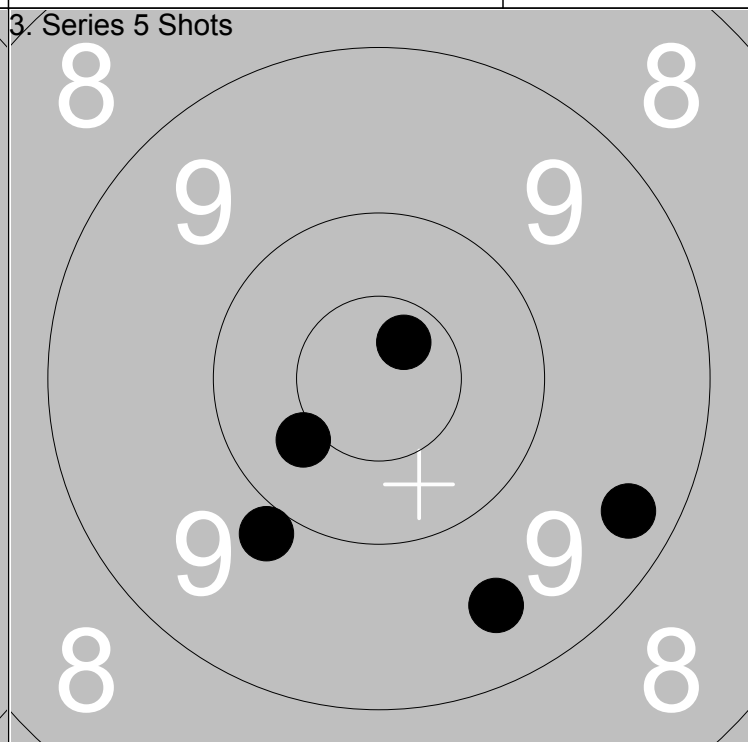
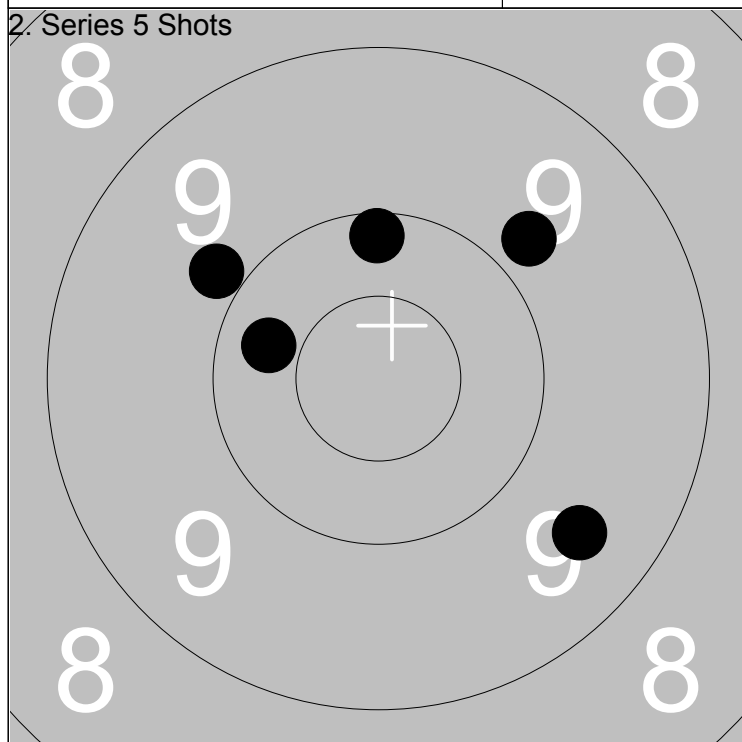

1: 9.9 ↖	Series	47.0
2: 10.2 ↑		
3: 10.3 ↖	Total	96.0
4: 9.8 ↗		
5: 9.5 ↘		

1: 9.3 →	Series	47.0
2: 9.5 ↘		
3: 10.4 ↙	Total	143.0
4: 9.9 ↙		
5: *10.7 ↗		

Relay 2	Lane 10	Tony Jansson	
-------------------	-------------------	---------------------	--

300m	Ununge	B	St
------	--------	---	----

06.07.2014	Tavelträffen 2014	Ramselefors SKF
------------	-------------------	-----------------

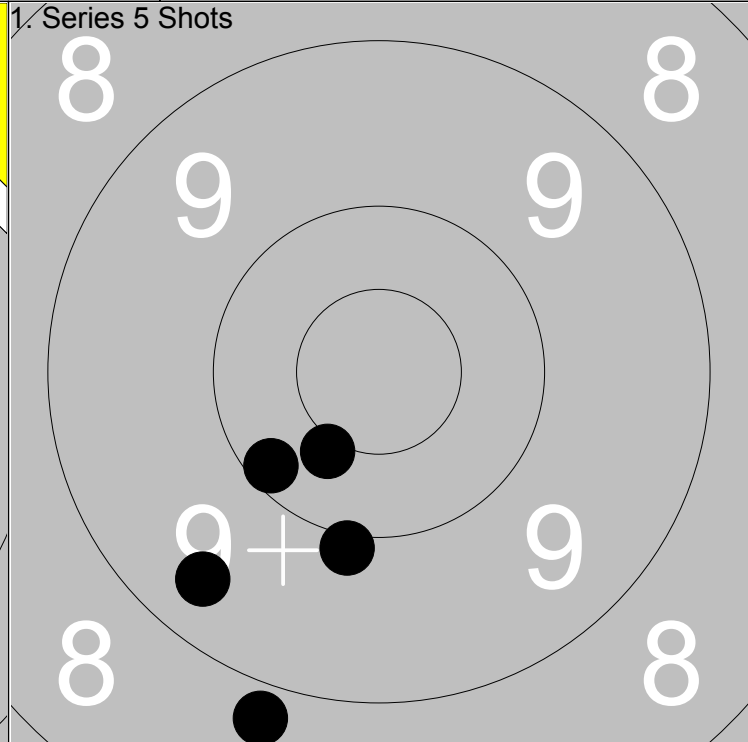
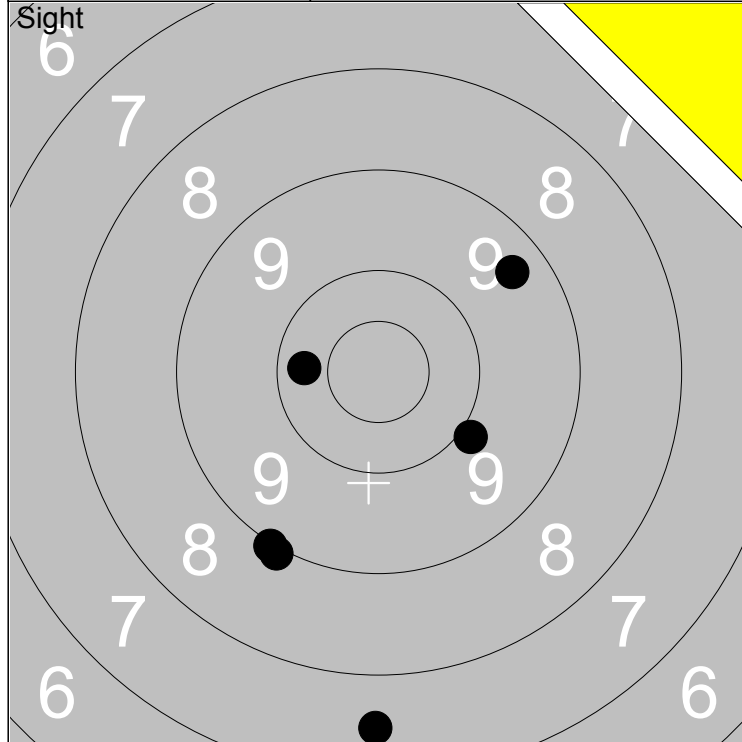

1: 9.9 ↘	6: 9.0 ↙	Series 53.0
2: 7.5 ↓		
3: 10.3 ←		Total 0.0
4: 9.0 ↙		
5: 9.4 ↗		

1: 10.2 ↙	Series 46.0
2: 8.8 ↓	
3: 9.9 ↓	Total 46.0
4: *10.4 ↙	
5: 9.4 ↙	

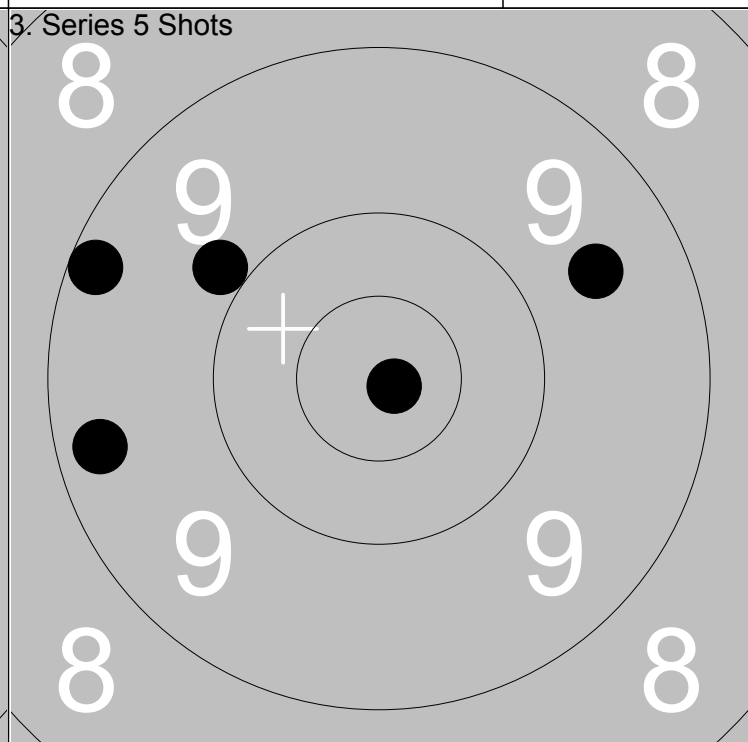
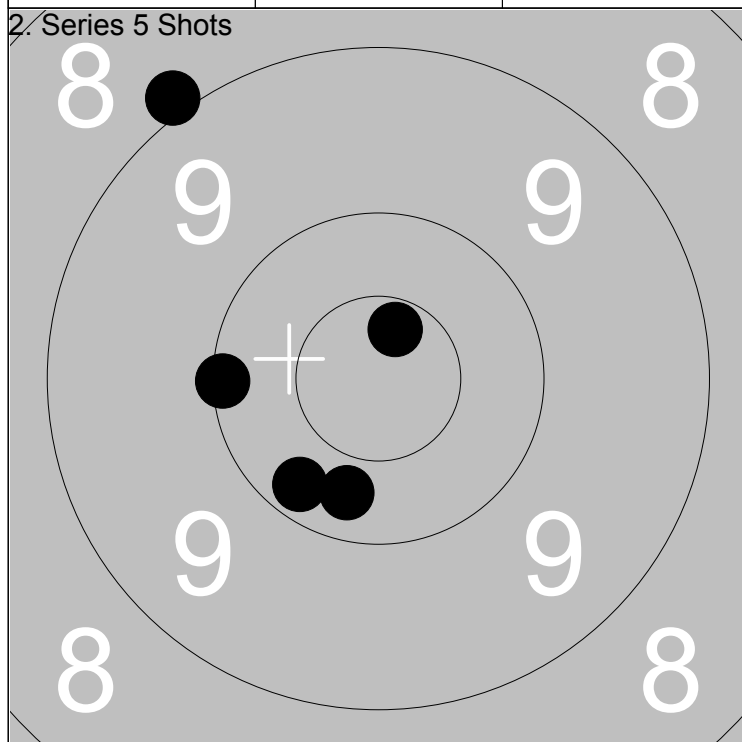

1: *10.7 ↑	Series 48.0
2: 10.2 ↓	
3: 10.1 ←	Total 94.0
4: 10.3 ↓	
5: 8.9 ↖	

1: 9.6 ↗	Series 46.0
2: *10.9 ↘	
3: 9.9 ↖	Total 140.0
4: 9.3 ←	
5: 9.2 ↖	

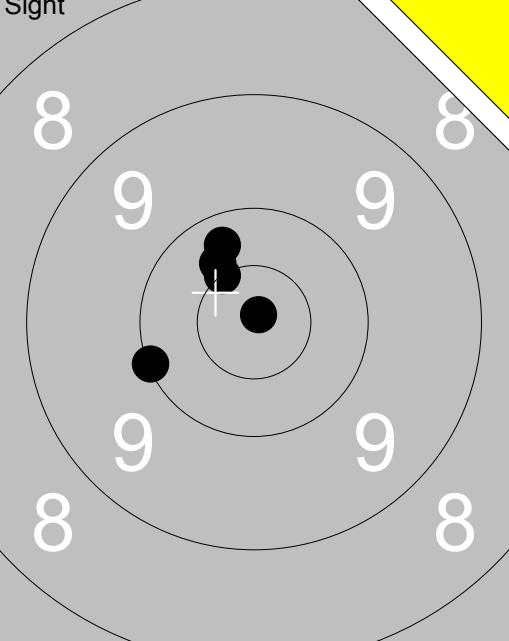
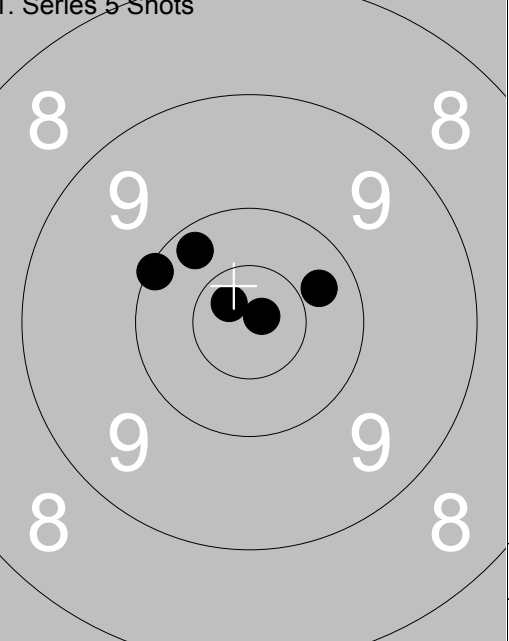
<p>Sight</p> 	<p>1: 10.0 ↙ 2: *10.9 ↗ 3: 10.3 ↗ 4: 10.4 ↗ 5: *10.5 ↗</p>	<p>1. Series 5 Shots</p> 		<p>1: 10.3 ↗ 2: *10.8 ↗ 3: 10.2 ↖ 4: 10.1 ↖ 5: *10.7 ↖</p>									
<table border="1" style="float: right; border-collapse: collapse;"> <tr><td>Series</td><td>50.0</td></tr> <tr><td>Total</td><td>0.0</td></tr> </table>		Series	50.0	Total	0.0			<table border="1" style="float: right; border-collapse: collapse;"> <tr><td>Series</td><td>50.0</td></tr> <tr><td>Total</td><td>50.0</td></tr> </table>		Series	50.0	Total	50.0
Series	50.0												
Total	0.0												
Series	50.0												
Total	50.0												

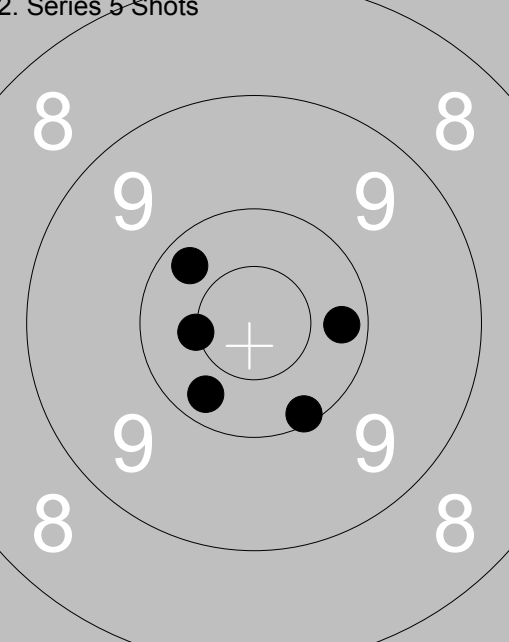
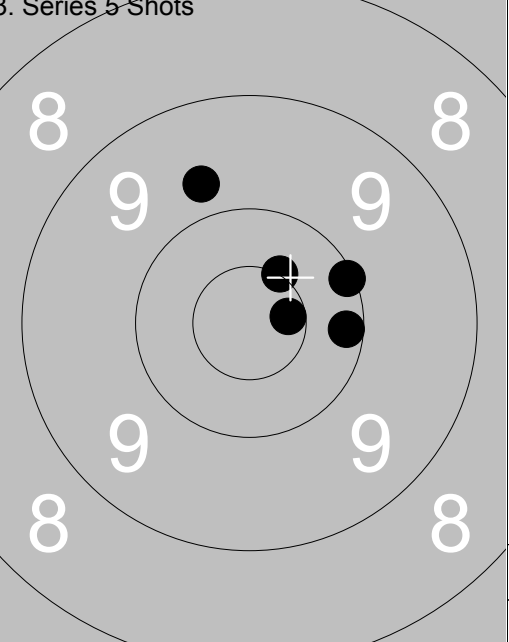
<p>2. Series 5 Shots</p> 	<p>1: 10.1 ↘ 2: 10.2 → 3: 10.3 ↘ 4: *10.5 ← 5: 10.2 ↘</p>	<p>3. Series 5 Shots</p> 		<p>1: 10.2 → 2: *10.5 ↗ 3: 10.1 → 4: 9.7 ↗ 5: *10.6 →</p>									
<table border="1" style="float: right; border-collapse: collapse;"> <tr><td>Series</td><td>50.0</td></tr> <tr><td>Total</td><td>100.0</td></tr> </table>		Series	50.0	Total	100.0			<table border="1" style="float: right; border-collapse: collapse;"> <tr><td>Series</td><td>49.0</td></tr> <tr><td>Total</td><td>149.0</td></tr> </table>		Series	49.0	Total	149.0
Series	50.0												
Total	100.0												
Series	49.0												
Total	149.0												

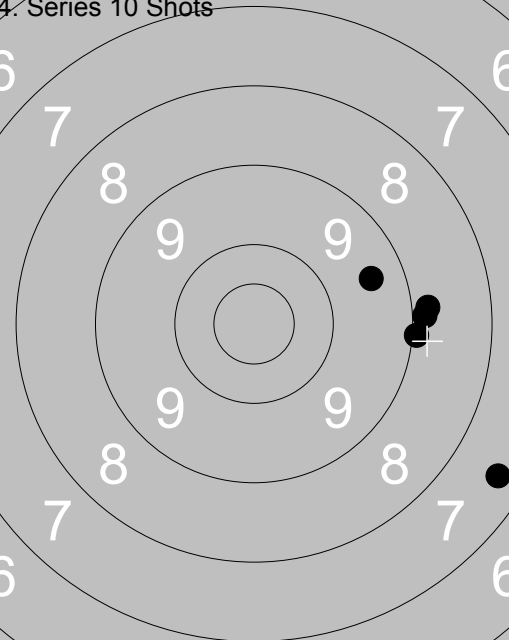
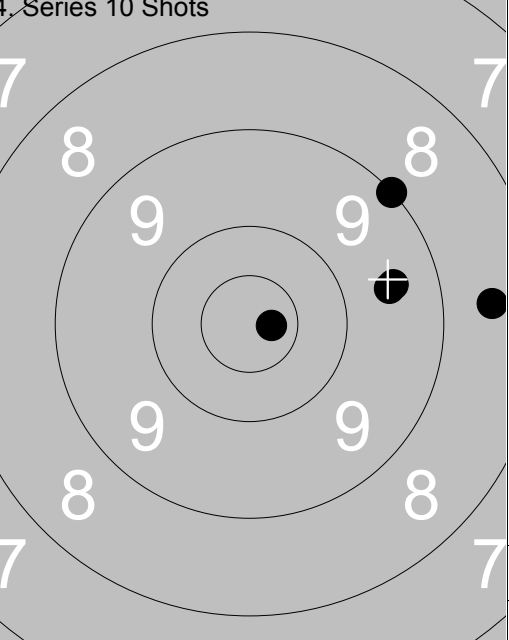
<p>4. Series 10 Shots</p> 	<p>1: 9.0 → 2: 8.9 → 3: 7.4 → 4: 9.4 → 5: 8.8 →</p>	<p>4. Series 10 Shots</p> 		<p>6: 9.5 → 7: 8.5 → 8: 9.0 ↗ 9: 9.5 → 10: *10.7 →</p>									
<table border="1" style="float: right; border-collapse: collapse;"> <tr><td>Series</td><td>41.0</td></tr> <tr><td>Total</td><td>190.0</td></tr> </table>		Series	41.0	Total	190.0			<table border="1" style="float: right; border-collapse: collapse;"> <tr><td>Series</td><td>45.0</td></tr> <tr><td>Total</td><td>235.0</td></tr> </table>		Series	45.0	Total	235.0
Series	41.0												
Total	190.0												
Series	45.0												
Total	235.0												

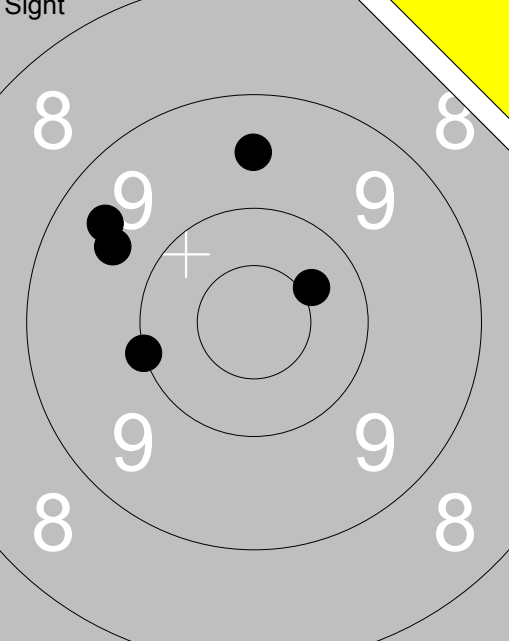
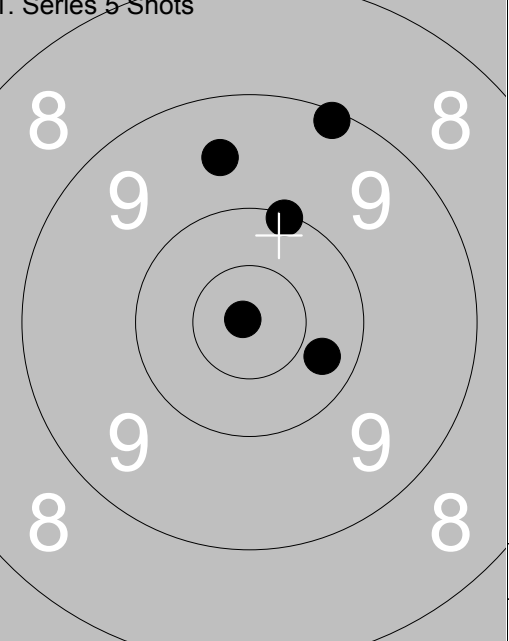
<p>Sight</p> 	<p>1: 9.5 ↑ 2: 10.0 ← 3: 10.4 ↗ 4: 9.5 ↖ 5: 9.6 ↖</p>	<p>1. Series 5 Shots</p> 	<p>1: 10.3 → 2: *10.9 ↖ 3: 10.1 ↑ 4: 9.1 ↑ 5: 9.6 ↑</p>
Series 47.0		Series 48.0	
Total 0.0		Total 48.0	

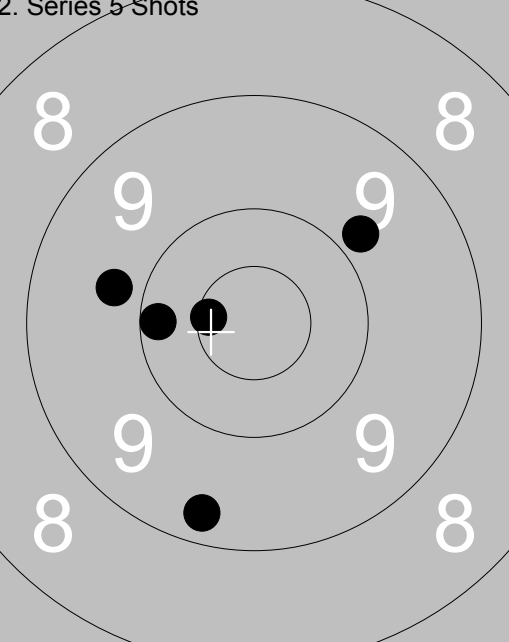
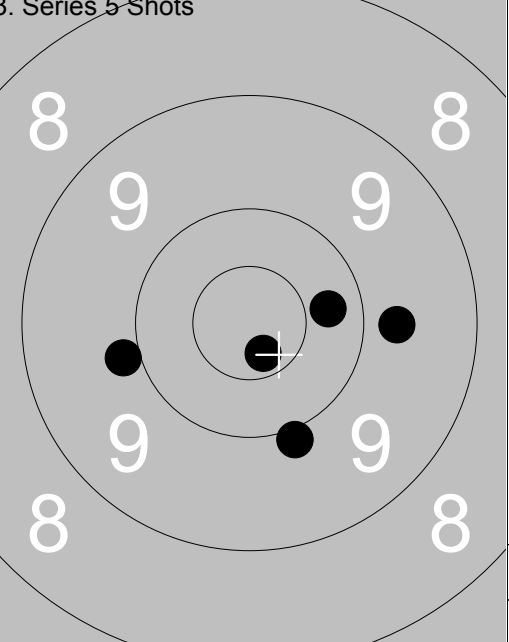
<p>2. Series 5 Shots</p> 	<p>1: 9.8 ← 2: 10.2 ← 3: 9.8 ↗ 4: *10.6 ← 5: 9.3 ↓</p>	<p>3. Series 5 Shots</p> 	<p>1: *10.7 ↓ 2: 10.3 → 3: 9.9 ↓ 4: 9.7 → 5: 9.9 ←</p>
Series 47.0		Series 47.0	
Total 95.0		Total 142.0	

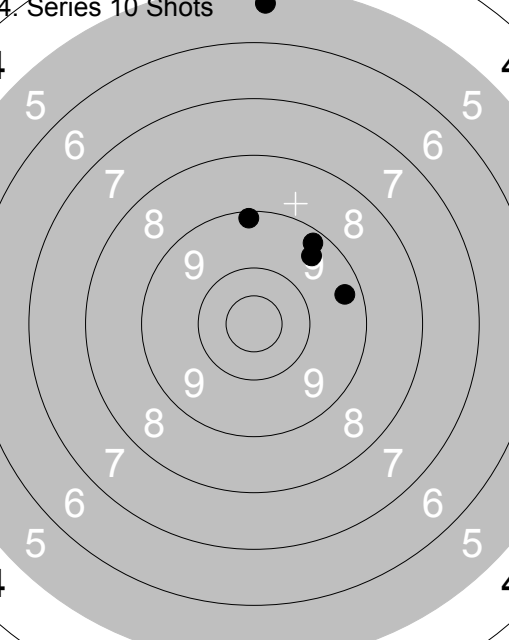
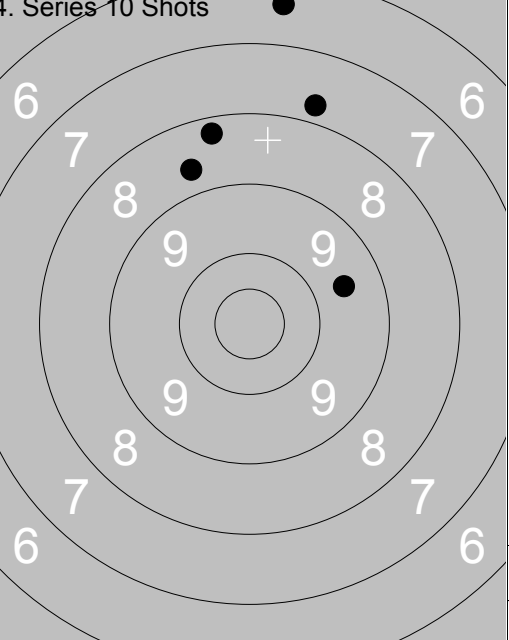
<p>4. Series 10 Shots</p> 	<p>1: 9.1 ↑ 2: 9.5 ↗ 3: 9.3 → 4: 5.3 ↑ 5: 9.3 ↗</p>	<p>4. Series 10 Shots</p> 	<p>6: 7.8 ↑ 7: 8.3 ↑ 8: 6.4 ↑ 9: 9.6 → 10: 8.7 ↖</p>
Series 41.0		Series 38.0	
Total 183.0		Total 221.0	

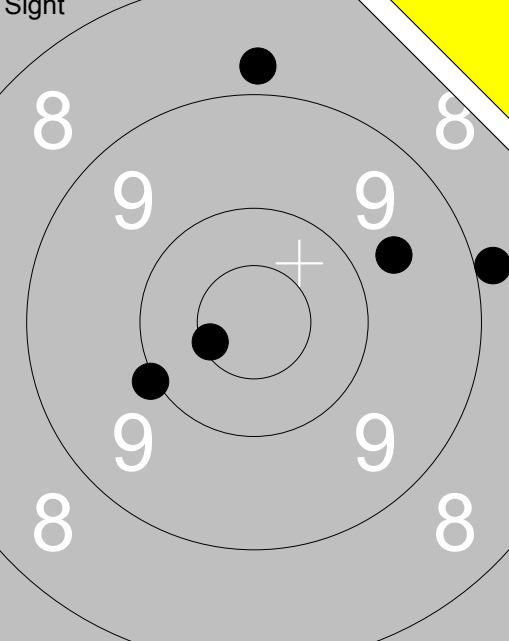
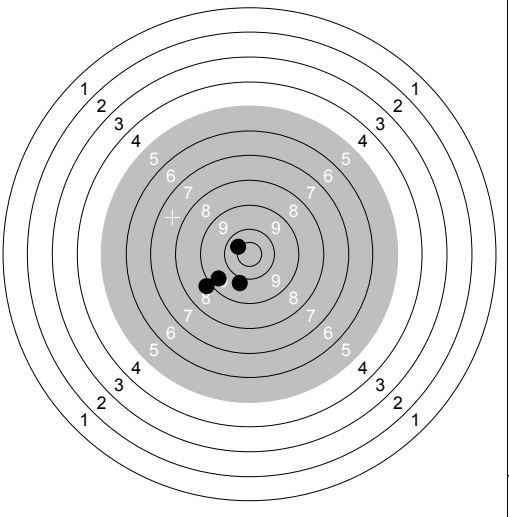
 <p>Sight</p>	<p>1: 8.9 →</p> <p>2: 9.7 →</p> <p>3: *10.6 ↙</p> <p>4: 8.8 ↑</p> <p>5: 10.0 ↙</p>	<p>1. Series 5 Shots</p> 	<p>1: *10.4 ↘</p> <p>2: 9.8 ↓</p> <p>3: 9.4 ↙</p> <p>4: 8.9 ↙</p> <p>5: 0.0 ↙</p>								
<table border="1" style="border-collapse: collapse;"> <tr><td>Series</td><td>45.0</td></tr> <tr><td>Total</td><td>0.0</td></tr> </table>		Series	45.0	Total	0.0	<table border="1" style="border-collapse: collapse;"> <tr><td>Series</td><td>36.0</td></tr> <tr><td>Total</td><td>36.0</td></tr> </table>		Series	36.0	Total	36.0
Series	45.0										
Total	0.0										
Series	36.0										
Total	36.0										

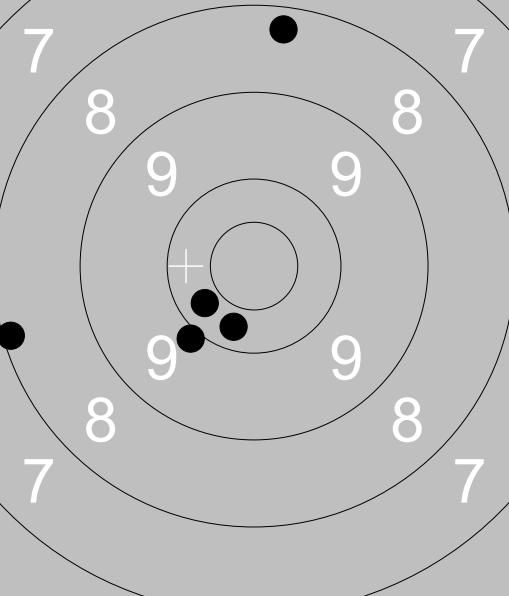
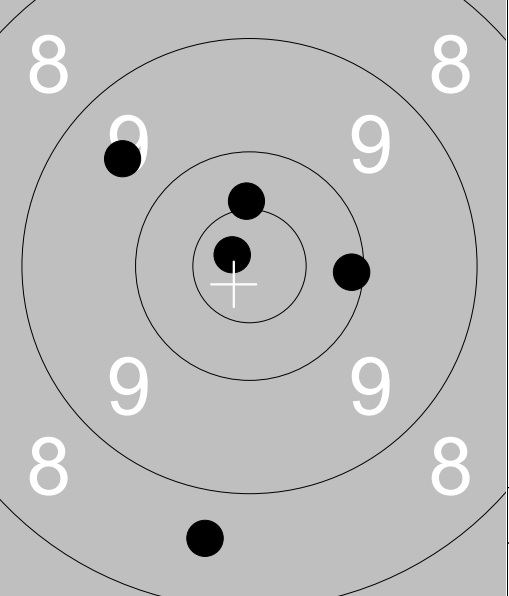
<p>2. Series 5 Shots</p> 	<p>1: 8.3 ↑</p> <p>2: 10.3 ↙</p> <p>3: 10.3 ↓</p> <p>4: 8.1 ←</p> <p>5: 9.9 ↙</p>	<p>3. Series 5 Shots</p> 	<p>1: 9.6 ↙</p> <p>2: *10.8 ↘</p> <p>3: 10.1 →</p> <p>4: *10.4 ↑</p> <p>5: 8.6 ↓</p>								
<table border="1" style="border-collapse: collapse;"> <tr><td>Series</td><td>45.0</td></tr> <tr><td>Total</td><td>81.0</td></tr> </table>		Series	45.0	Total	81.0	<table border="1" style="border-collapse: collapse;"> <tr><td>Series</td><td>47.0</td></tr> <tr><td>Total</td><td>128.0</td></tr> </table>		Series	47.0	Total	128.0
Series	45.0										
Total	81.0										
Series	47.0										
Total	128.0										

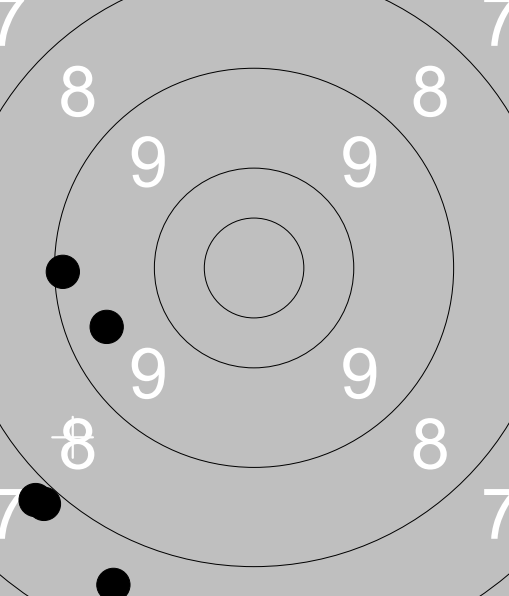
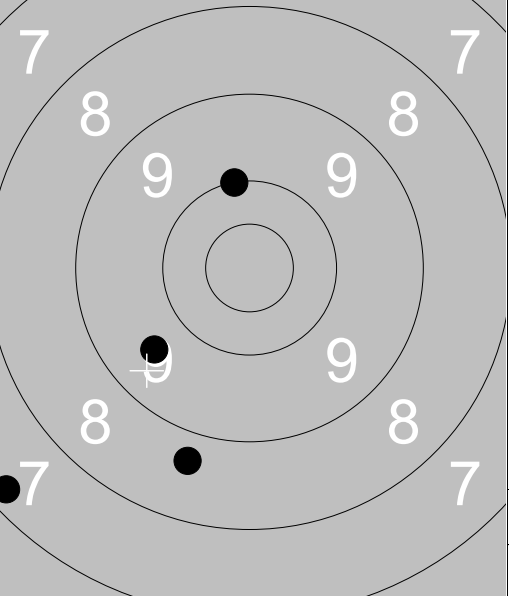
<p>4. Series 10 Shots</p> 	<p>1: 7.8 ↙</p> <p>2: 7.5 ↓</p> <p>3: 9.1 ←</p> <p>4: 9.4 ←</p> <p>5: 7.9 ↙</p>	<p>4. Series 10 Shots</p> 	<p>6: 9.6 ↙</p> <p>7: 7.2 ↙</p> <p>8: 8.7 ↓</p> <p>9: 10.0 ↑</p>								
<table border="1" style="border-collapse: collapse;"> <tr><td>Series</td><td>39.0</td></tr> <tr><td>Total</td><td>167.0</td></tr> </table>		Series	39.0	Total	167.0	<table border="1" style="border-collapse: collapse;"> <tr><td>Series</td><td>34.0</td></tr> <tr><td>Total</td><td>201.0</td></tr> </table>		Series	34.0	Total	201.0
Series	39.0										
Total	167.0										
Series	34.0										
Total	201.0										

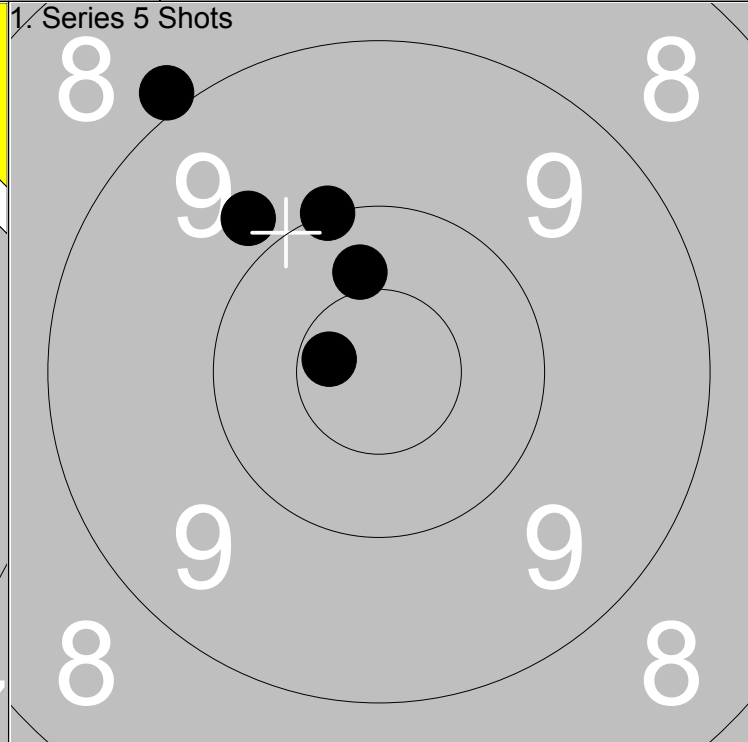
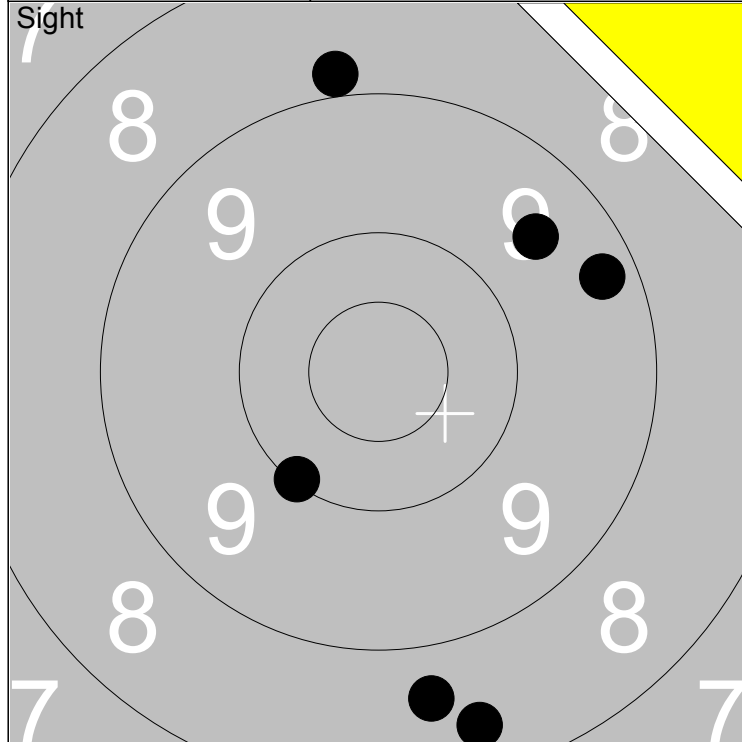

1: 8.9 ↑	6: 9.3 →	Series	52.0
2: 8.4 ↓		Total	0.0
3: 8.7 ↓			
4: 10.1 ↘			
5: 9.5 ↗			

1: 9.8 ↖	Series	47.0
2: 10.0 ↑	Total	47.0
3: 8.9 ↖		
4: 10.4 ↑		
5: *10.7 ↙		

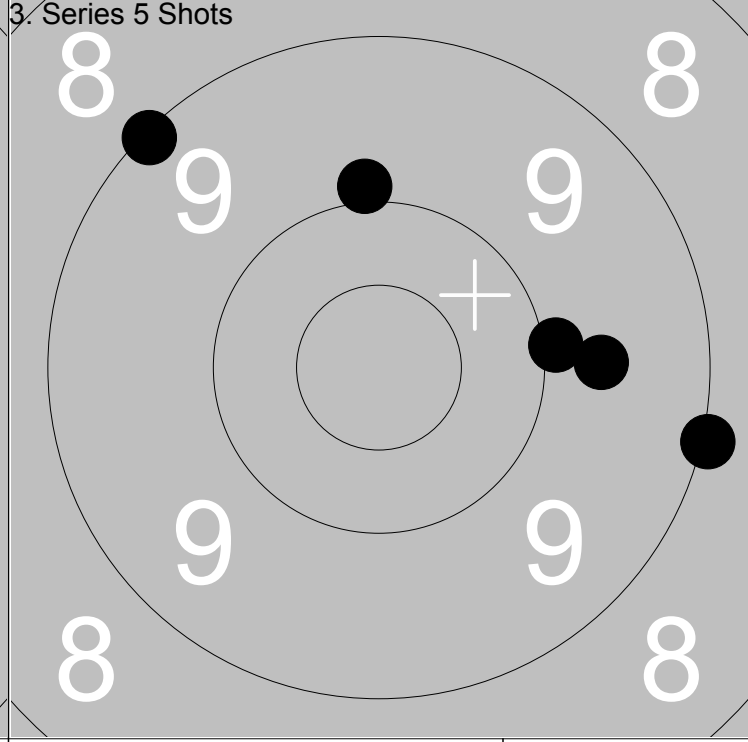
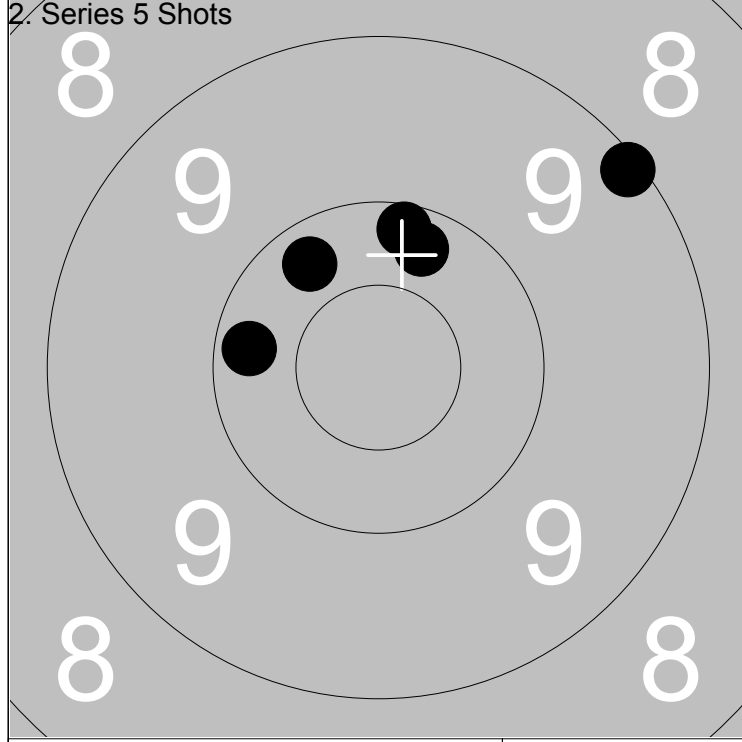

1: 10.3 ↖	Series	49.0
2: 10.2 ↑	Total	96.0
3: 10.2 ↑		
4: 10.2 ↙		
5: 9.1 ↗		

1: 10.0 →	Series	46.0
2: 9.9 ↑	Total	142.0
3: 9.0 →		
4: 9.7 →		
5: 9.1 ↖		

<p>Sight</p> <p>1: *10.7 ↘ 2: 9.4 ↑ 3: 9.4 ← 4: 10.1 ↗</p>	<p>1. Series 5 Shots</p> <p>1: *10.8 ↘ 2: 10.0 ↖ 3: 9.7 → 4: 9.5 → 5: 10.1 →</p>	
Series 38.0	Series 48.0	
Total 0.0	Total 48.0	

<p>2. Series 5 Shots</p> <p>1: 10.2 ↑ 2: 9.7 ↗ 3: 10.4 → 4: 10.1 ↓ 5: 9.4 ↘</p>	<p>3. Series 5 Shots</p> <p>1: 10.3 ↘ 2: 9.3 ↓ 3: 8.8 → 4: 9.1 → 5: 9.8 ←</p>	
Series 48.0	Series 45.0	
Total 96.0	Total 141.0	

<p>4. Series 10 Shots</p> <p>1: *10.6 ↘ 2: 9.4 ↑ 3: 6.6 ↑ 4: *10.7 ↖ 5: 8.7 ↖</p>	<p>4. Series 10 Shots</p> <p>6: 8.0 ↑ 7: 9.0 ↑ 8: 9.4 ↖ 9: 7.0 ↗ 10: 8.6 ↗</p>	
Series 43.0	Series 41.0	
Total 184.0	Total 225.0	

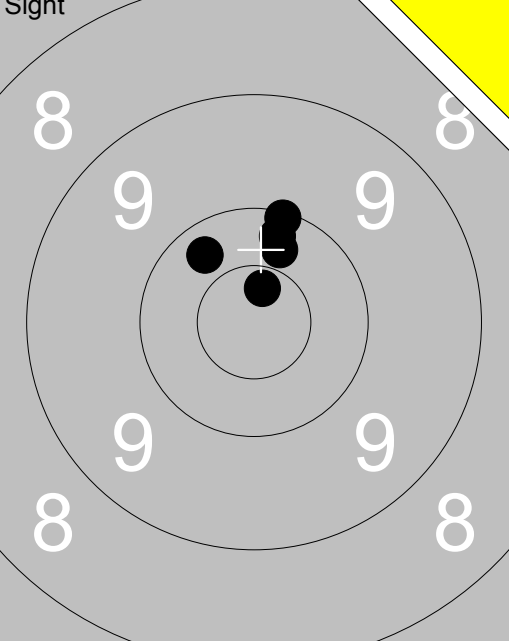
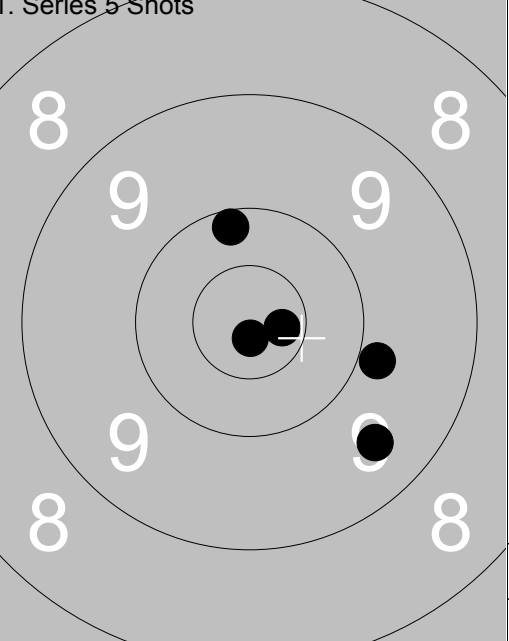
<p>Sight</p> 	<p>1: 10.3 ↖ 2: *10.7 ↗ 3: 10.3 ↗ 4: 10.1 ↗ 5: 10.2 ↗</p>	<p>1. Series 5 Shots</p> 	<p>1: 10.2 ↗ 2: *10.7 → 3: 9.9 → 4: 9.5 ↘ 5: *10.8 ↘</p>								
<table border="1" style="border-collapse: collapse;"> <tr><td>Series</td><td>50.0</td></tr> <tr><td>Total</td><td>0.0</td></tr> </table>		Series	50.0	Total	0.0	<table border="1" style="border-collapse: collapse;"> <tr><td>Series</td><td>48.0</td></tr> <tr><td>Total</td><td>48.0</td></tr> </table>		Series	48.0	Total	48.0
Series	50.0										
Total	0.0										
Series	48.0										
Total	48.0										

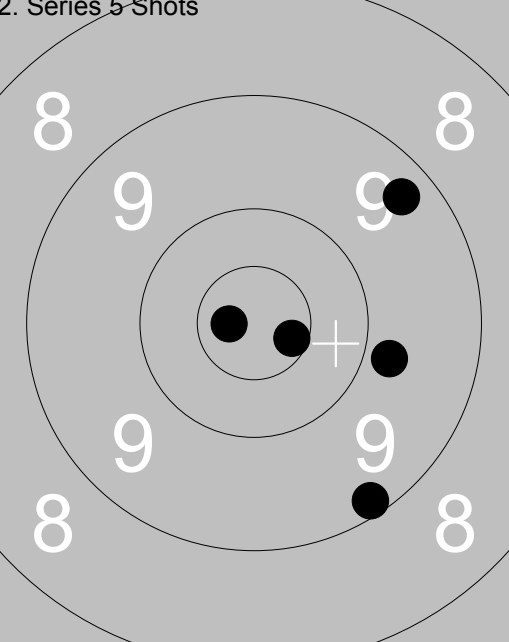
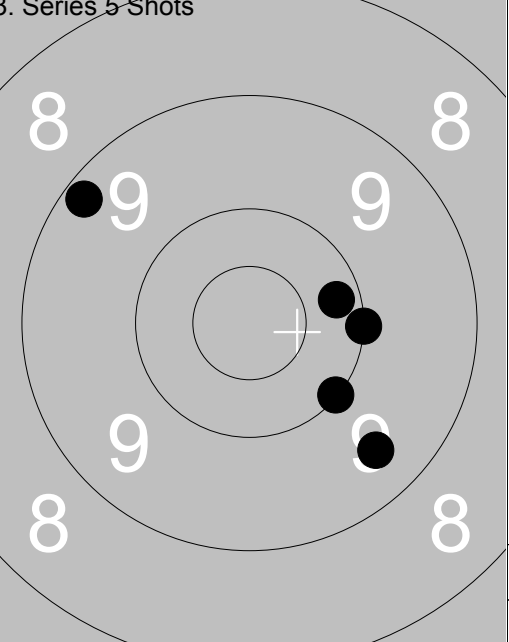
<p>2. Series 5 Shots</p> 	<p>1: *10.8 ← 2: *10.6 → 3: 9.3 ↗ 4: 9.2 ↘ 5: 9.8 →</p>	<p>3. Series 5 Shots</p> 	<p>1: 9.2 ↖ 2: 10.2 → 3: 10.0 → 4: 10.0 ↘ 5: 9.5 ↘</p>								
<table border="1" style="border-collapse: collapse;"> <tr><td>Series</td><td>47.0</td></tr> <tr><td>Total</td><td>95.0</td></tr> </table>		Series	47.0	Total	95.0	<table border="1" style="border-collapse: collapse;"> <tr><td>Series</td><td>48.0</td></tr> <tr><td>Total</td><td>143.0</td></tr> </table>		Series	48.0	Total	143.0
Series	47.0										
Total	95.0										
Series	48.0										
Total	143.0										

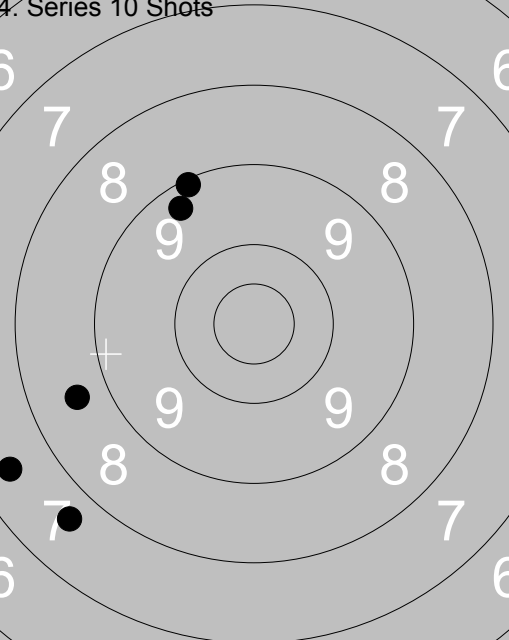
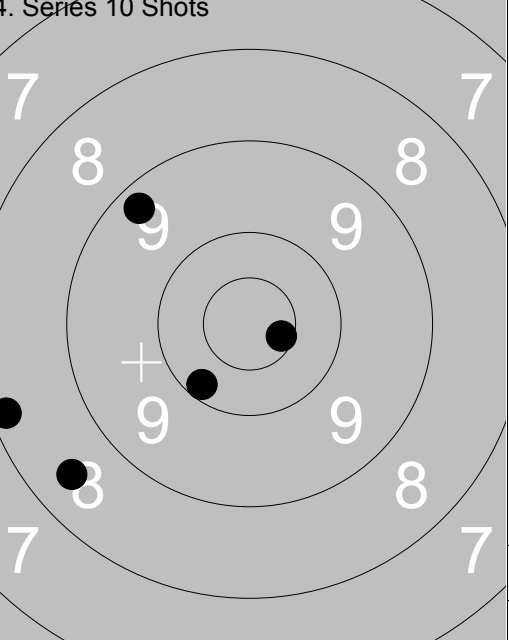
<p>4. Series 10 Shots</p> 	<p>1: 9.3 ↖ 2: 9.1 ↗ 3: 7.5 ← 4: 8.6 ← 5: 7.7 ↘</p>	<p>4. Series 10 Shots</p> 	<p>6: 9.3 ↖ 7: *10.6 → 8: 10.2 ↘ 9: 8.2 ← 10: 8.5 ↘</p>								
<table border="1" style="border-collapse: collapse;"> <tr><td>Series</td><td>40.0</td></tr> <tr><td>Total</td><td>183.0</td></tr> </table>		Series	40.0	Total	183.0	<table border="1" style="border-collapse: collapse;"> <tr><td>Series</td><td>45.0</td></tr> <tr><td>Total</td><td>228.0</td></tr> </table>		Series	45.0	Total	228.0
Series	40.0										
Total	183.0										
Series	45.0										
Total	228.0										

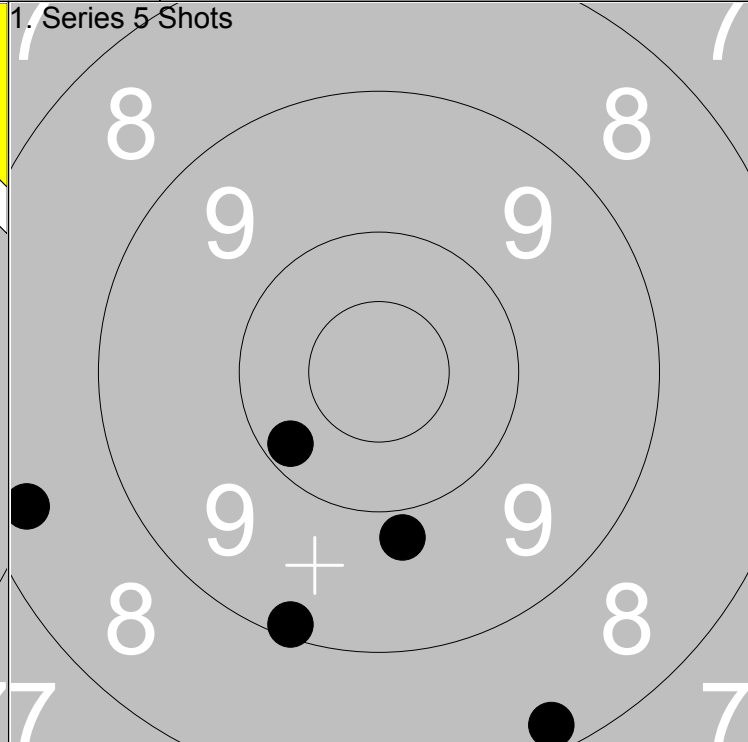
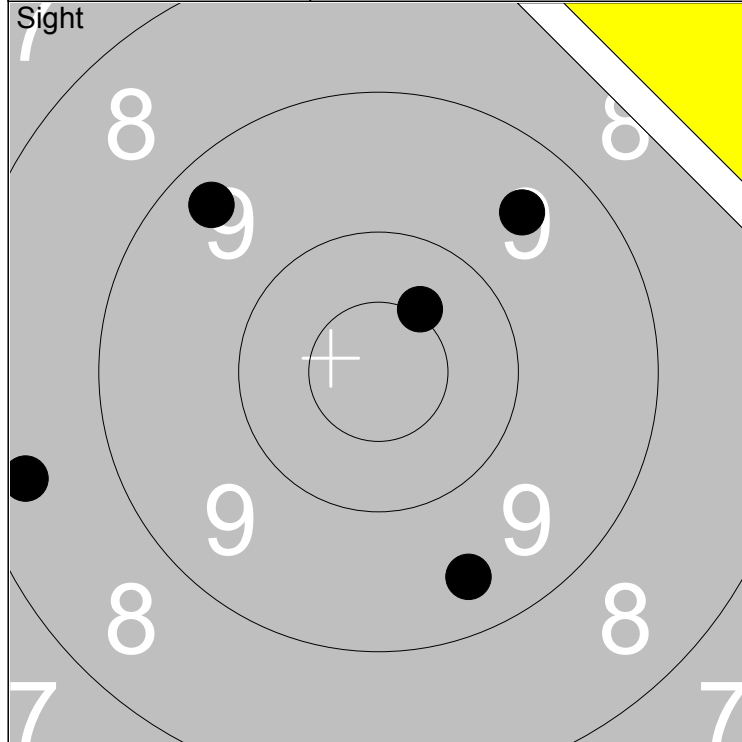

1: 8.4 ←	Series	45.0
2: 9.5 ↗		
3: *10.5 ↗		
4: 9.4 ↓		
5: 9.3 ↖		
Total		0.0

1: 9.1 ↓	Series	44.0
2: 10.2 ↙		
3: 8.2 ↓		
4: 9.8 ↓		
5: 8.3 ←		
Total		44.0

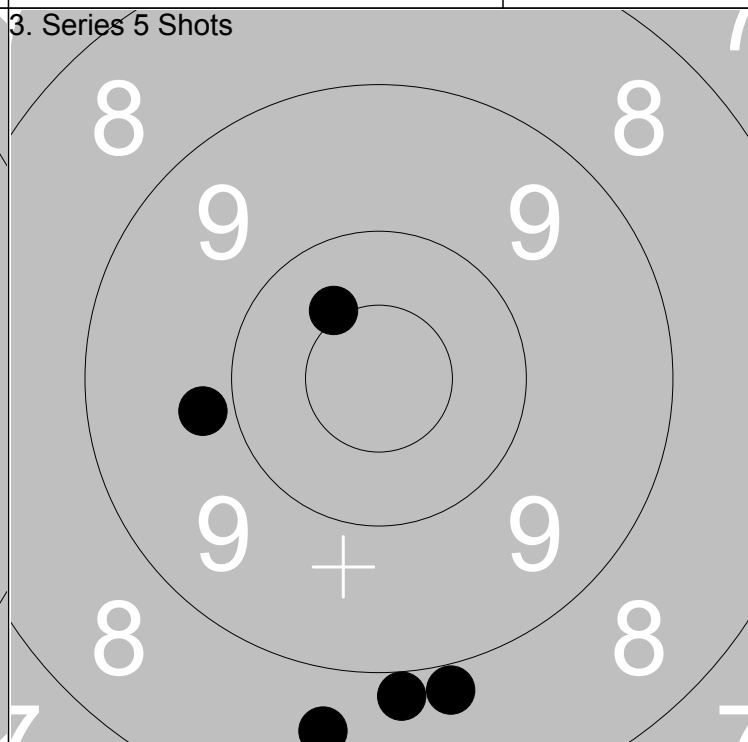
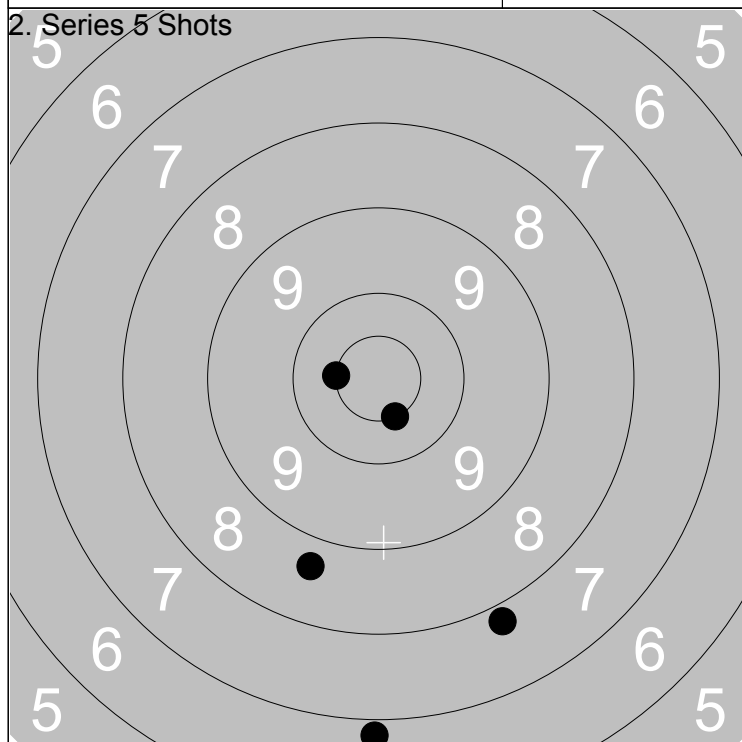

1: 8.7 ↓	Series	41.0
2: 6.8 ↓		
3: *10.5 ←		
4: 7.8 ↓		
5: *10.5 ↓		
Total		85.0

1: 9.8 ←	Series	43.0
2: 8.9 ↓		
3: 8.6 ↓		
4: *10.4 ↖		
5: 8.9 ↓		
Total		128.0

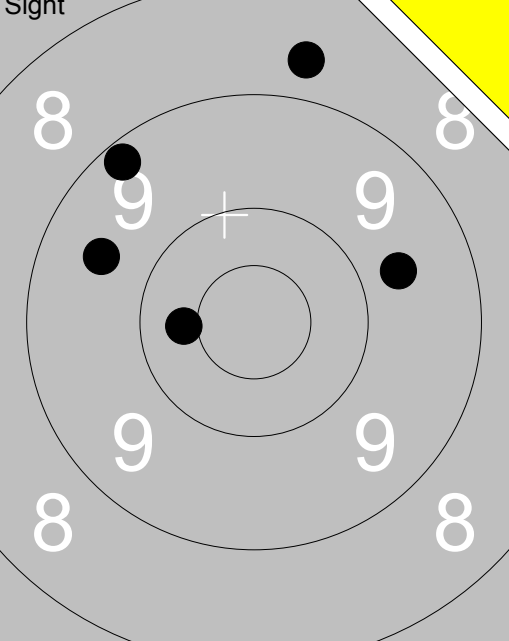
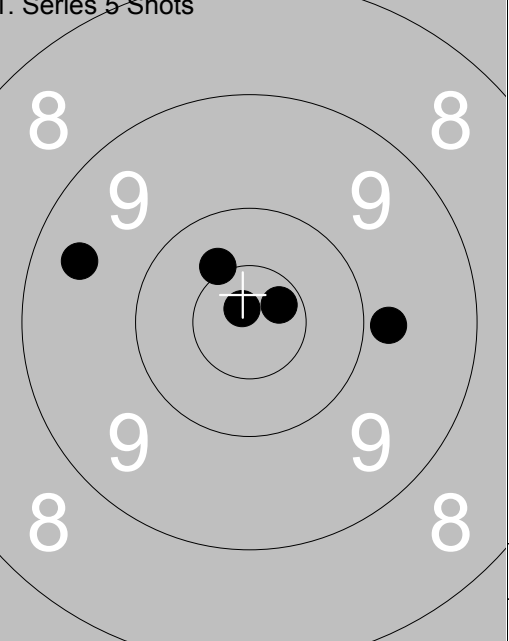
<p>Sight</p> 	<p>1: 9.2 ↖ 2: 8.7 ↑ 3: 9.6 ↙ 4: 10.4 ← 5: 9.7 →</p>	<p>1. Series 5 Shots</p> 		<p>1: *10.8 ↖ 2: *10.4 ↖ 3: *10.7 ↗ 4: 9.8 → 5: 9.4 ↙</p>
Series 45.0		Series 48.0		
Total 0.0		Total 48.0		

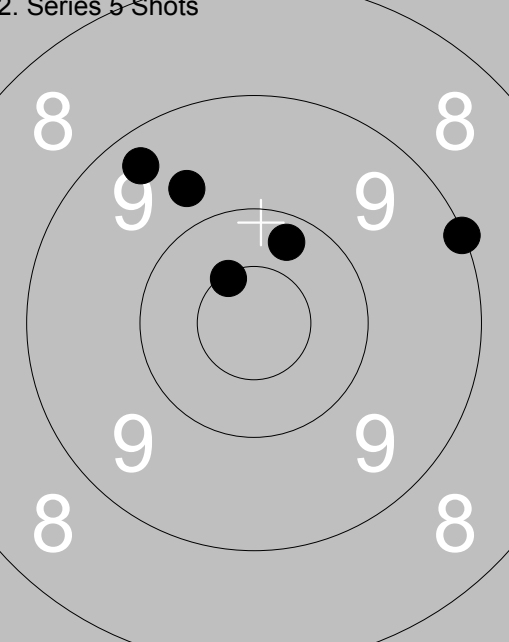
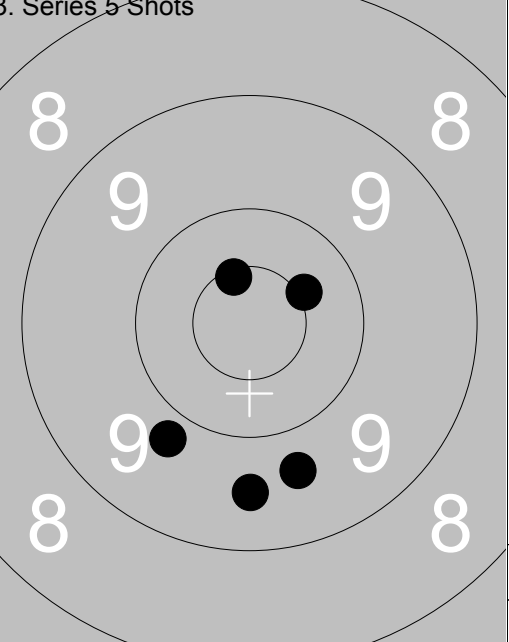
<p>2. Series 5 Shots</p> 	<p>1: 9.7 ↖ 2: 9.3 ↖ 3: *10.5 ↖ 4: 10.2 ↑ 5: 9.0 →</p>	<p>3. Series 5 Shots</p> 		<p>1: 9.8 ↙ 2: *10.6 ↖ 3: 9.5 ↓ 4: 9.7 ↓ 5: *10.4 ↗</p>
Series 47.0		Series 47.0		
Total 95.0		Total 142.0		

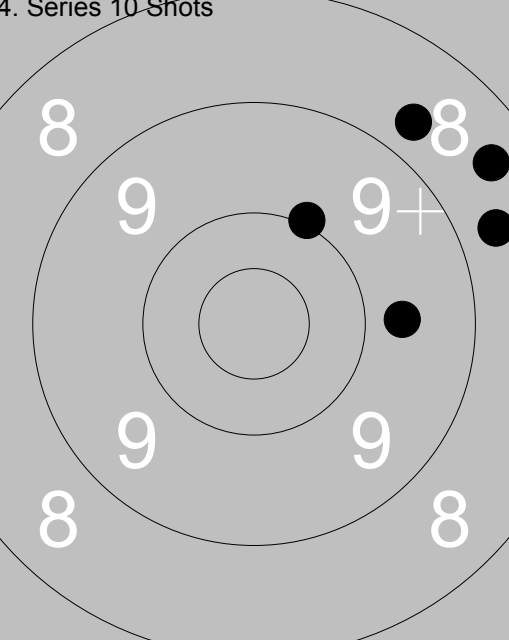
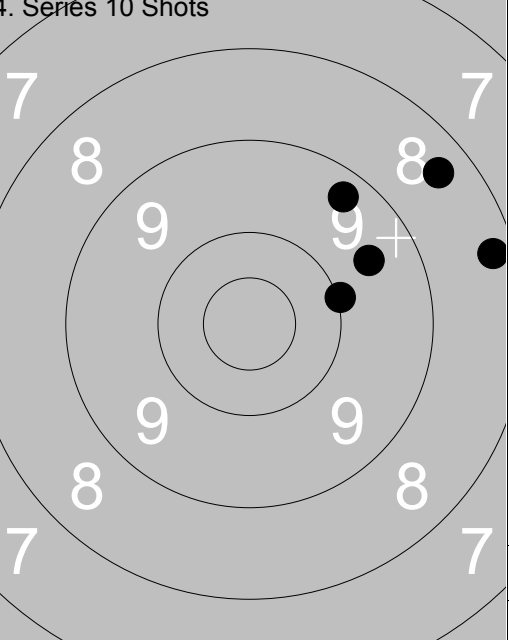
<p>4. Series 10 Shots</p> 	<p>1: 8.7 ↗ 2: 8.4 ↗ 3: 10.0 ↑ 4: 8.7 → 5: 9.7 →</p>	<p>4. Series 10 Shots</p> 		<p>6: 10.0 → 7: 8.3 → 8: 9.3 ↗ 9: 9.6 → 10: 8.4 ↗</p>
Series 43.0		Series 44.0		
Total 185.0		Total 229.0		

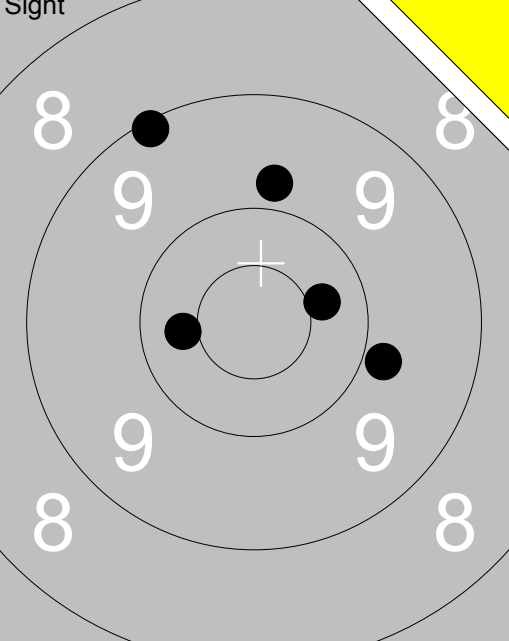
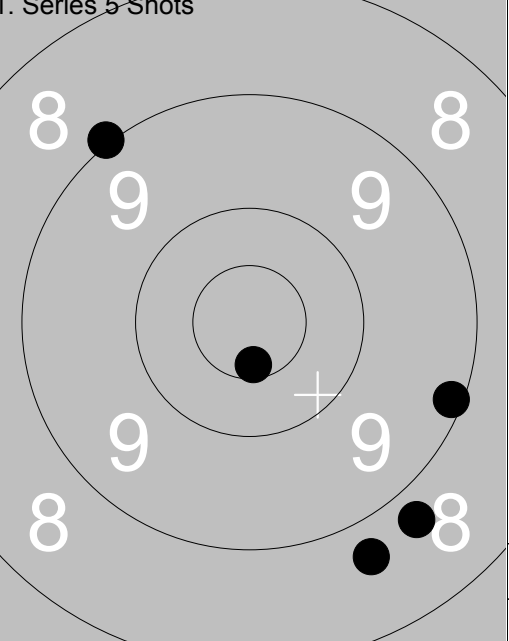
<p>Sight</p> 	<p>1: 9.8 ↑</p> <p>2: 9.1 ↗</p> <p>3: 9.8 →</p> <p>4: 10.4 →</p> <p>5: 10.4 ←</p>	<p>1. Series 5 Shots</p> 		<p>1: 9.0 ↗</p> <p>2: 8.7 ↘</p> <p>3: 8.8 ↘</p> <p>4: 9.1 →</p> <p>5: *10.6 ↘</p>
Series 47.0				Series 44.0
Total 0.0				Total 44.0

<p>2. Series 5 Shots</p> 	<p>1: 8.7 →</p> <p>2: 9.5 ↘</p> <p>3: 9.7 ↘</p> <p>4: 9.7 ↗</p> <p>5: 9.3 →</p>	<p>3. Series 5 Shots</p> 		<p>1: 10.0 ←</p> <p>2: *10.5 ↗</p> <p>3: *10.6 ↘</p> <p>4: *10.6 ←</p> <p>5: 10.4 →</p>
Series 44.0				Series 50.0
Total 88.0				Total 138.0

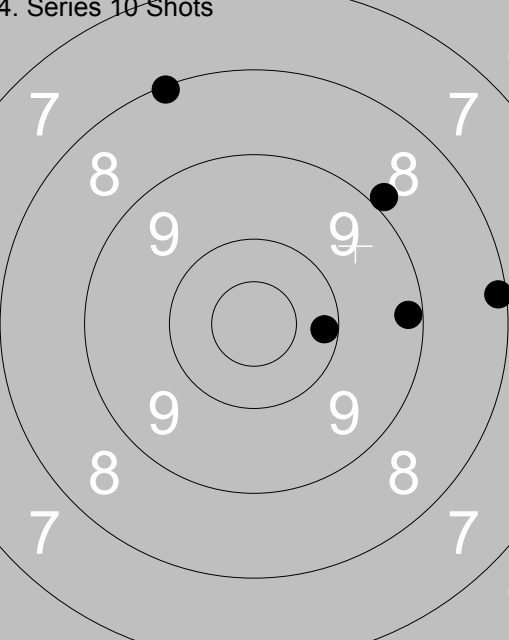
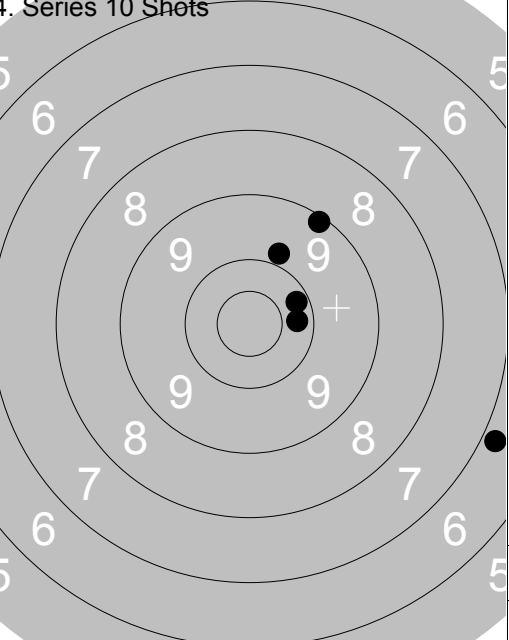
<p>4. Series 10 Shots</p> 	<p>1: 8.1 ↑</p> <p>2: 9.2 →</p> <p>3: 10.2 →</p> <p>4: 8.9 ↗</p> <p>5: 8.1 →</p>	<p>4. Series 10 Shots</p> 		<p>6: 10.3 →</p> <p>7: 9.8 ↗</p> <p>8: 10.2 →</p> <p>9: 9.1 ↗</p> <p>10: 6.8 →</p>
Series 43.0				Series 44.0
Total 181.0				Total 225.0

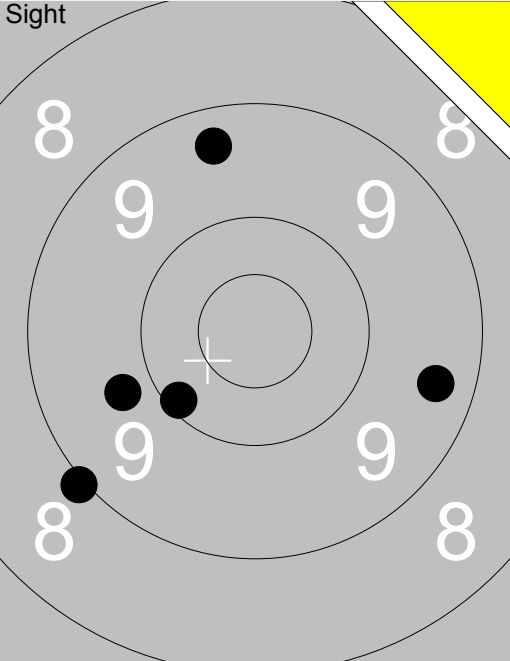
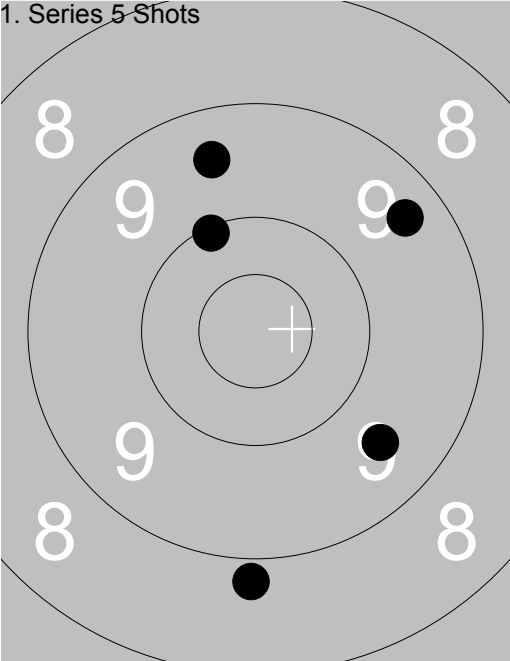
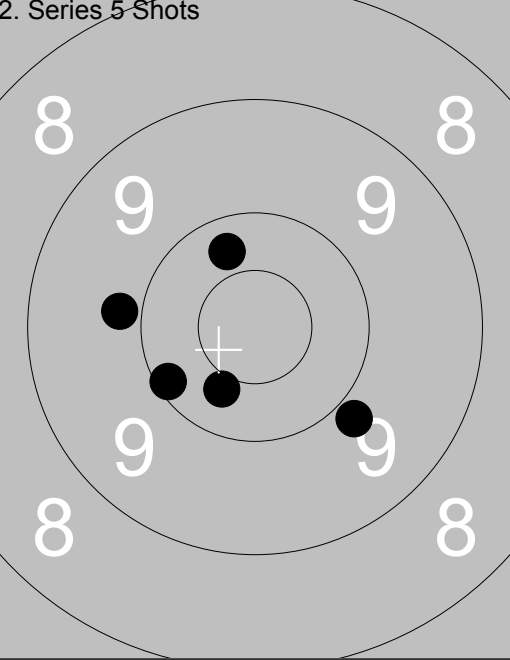
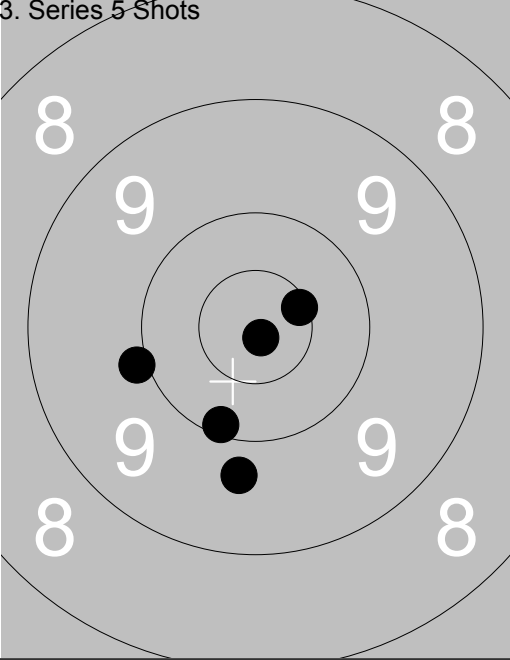
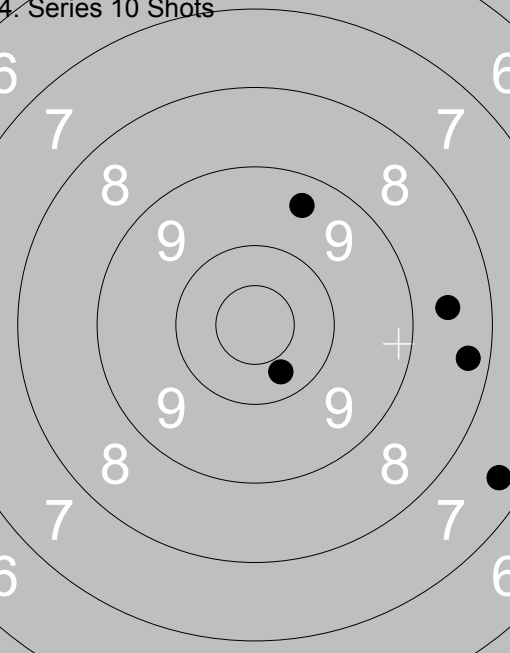
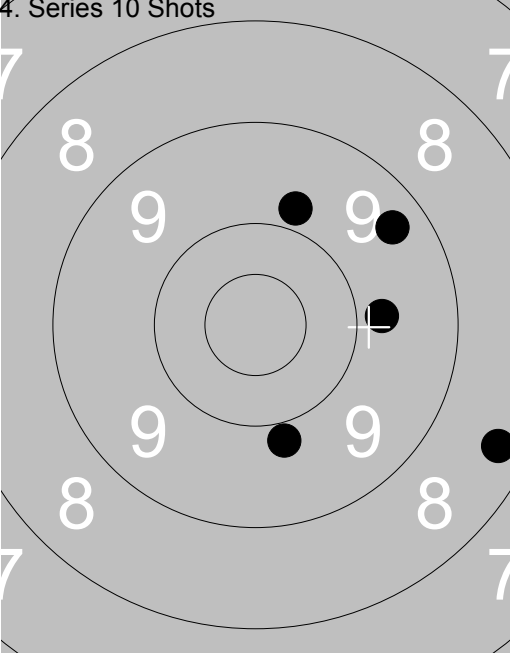
Relay	Lane	Johan Nilsson		
3	3			
300m		Ramselefors	B	Vb
06.07.2014		Tavelträffen 2014	Ramselefors SKF	
Sight		1: 9.4 ↑		1: 9.5 ↑
		2: 9.8 ↙		2: 10.1 ↗
		3: 9.0 ↙		3: 9.4 ↗
		4: 9.4 →		4: 8.8 ↓
		5: 10.1 ↙		5: 9.6 ↘
		Series 46.0		Series 45.0
		Total 0.0		Total 45.0
2. Series 5 Shots		1: 10.1 ↙		1: 9.7 ↓
		2: 9.8 ↘		2: 9.9 ↙
		3: 9.8 ↙		3: 10.1 ↓
		4: 10.3 ↑		4: *10.6 ↗
		5: 10.4 ↘		5: *10.9 ↘
		Series 48.0		Series 48.0
		Total 93.0		Total 141.0
4. Series 10 Shots		1: 9.4 ↑		6: 9.8 ↑
		2: 7.4 →		7: 9.9 ↓
		3: 10.3 ↓		8: 8.4 →
		4: 8.3 →		9: 9.8 →
		5: 8.6 →		10: 9.4 ↗
		Series 42.0		Series 44.0
		Total 183.0		Total 227.0

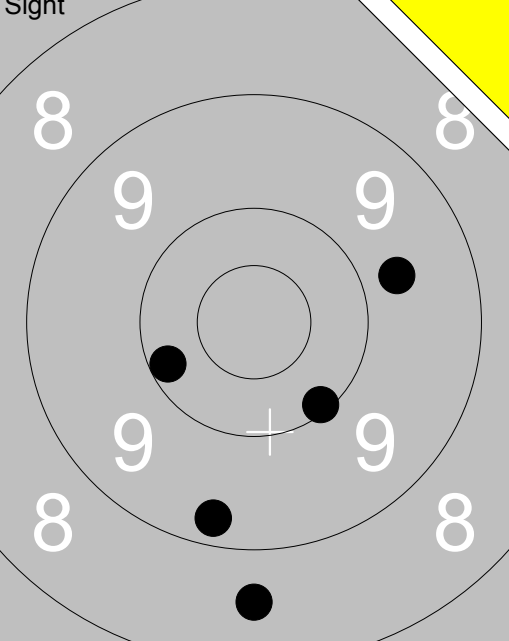
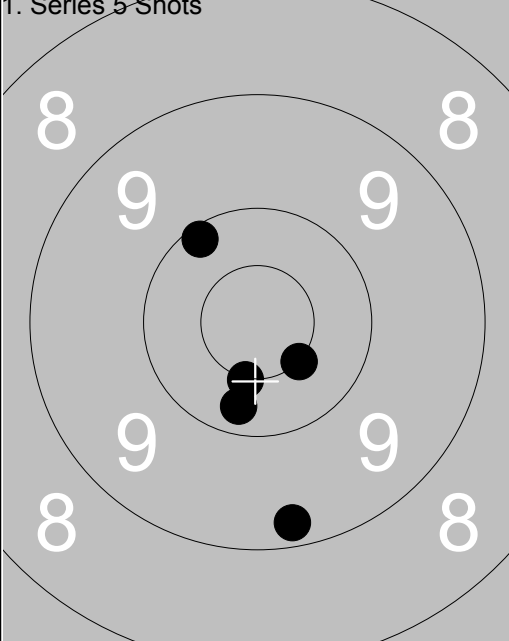
<p>Sight</p> 	<p>1. Series 5 Shots</p> 	<p>1: 10.1 ↘ 2: 9.3 ↓ 3: 8.6 ↓ 4: 9.7 → 5: 10.2 ↙</p> <p>1: *10.5 ↓ 2: 9.2 ↓ 3: 10.1 ↖ 4: *10.5 ↘ 5: 10.3 ↓</p>
Series 46.0	Series 49.0	
Total 0.0	Total 49.0	

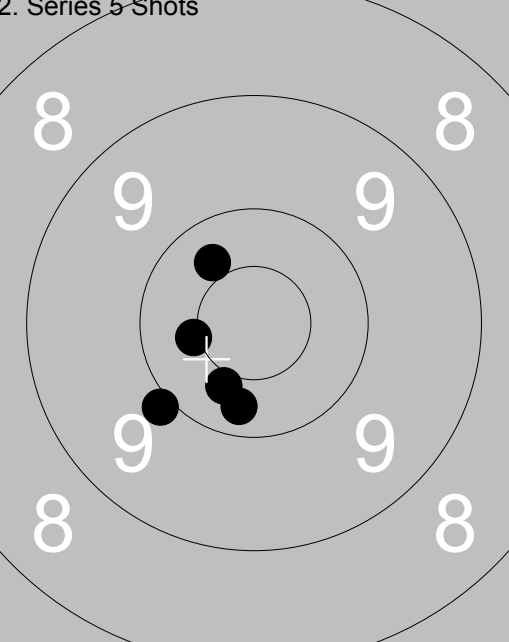
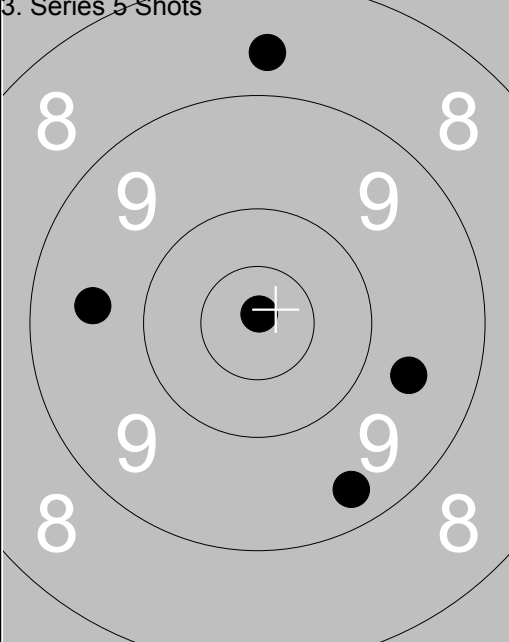
<p>2. Series 5 Shots</p> 	<p>3. Series 5 Shots</p> 	<p>1: 9.9 ↙ 2: 10.3 ↓ 3: 10.4 ↖ 4: *10.4 ↙ 5: 10.4 ↓</p> <p>1: 8.7 ↑ 2: 9.6 → 3: 9.4 ↓ 4: *10.9 ↑ 5: 9.6 ←</p>
Series 49.0	Series 45.0	
Total 98.0	Total 143.0	

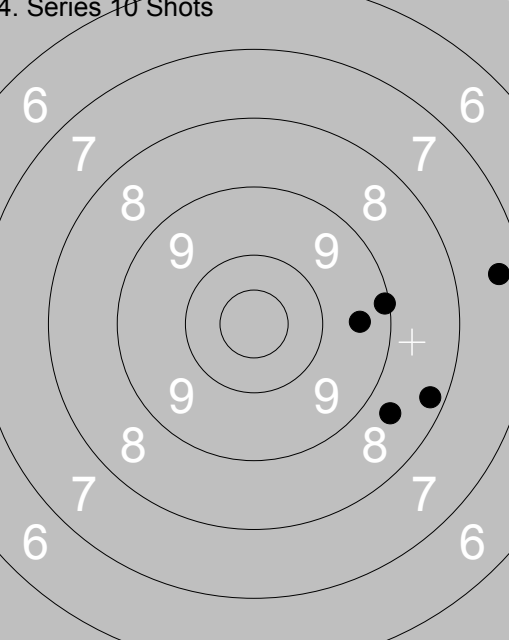
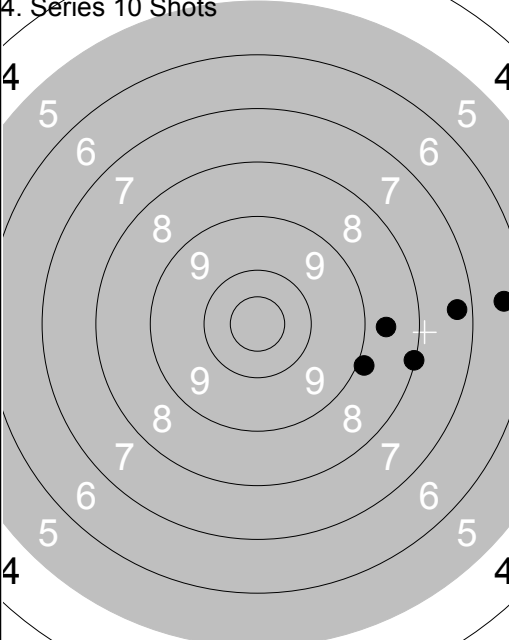
<p>4. Series 10 Shots</p> 	<p>4. Series 10 Shots</p> 	<p>1: 8.7 ↘ 2: 9.1 → 3: 9.5 → 4: 8.2 → 5: 7.4 →</p> <p>6: 8.0 → 7: 8.6 → 8: 8.9 → 9: 7.3 → 10: 6.4 →</p>
Series 41.04	Series 37.0	
Total 184.0	Total 221.0	

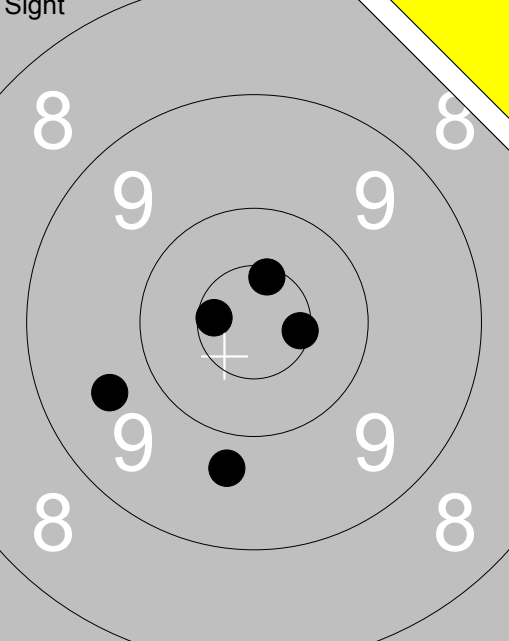
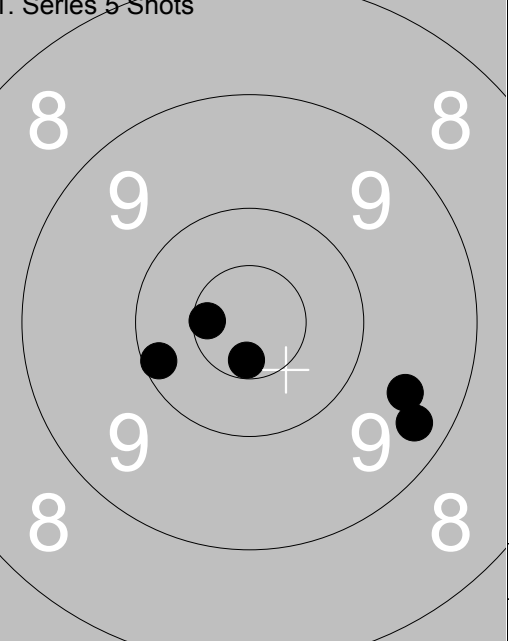
<p>Sight</p> 	<p>1: 9.6 ↙ 2: *10.6 ↗ 3: 9.7 ↓ 4: *10.6 ← 5: *10.6 →</p>	<p>1. Series 5 Shots</p> 		<p>1: *10.6 ← 2: 10.1 ↙ 3: *10.6 ↓ 4: 9.5 → 5: 9.3 ↘</p>	
Series 48.0				Series 48.0	
Total 0.0				Total 48.0	

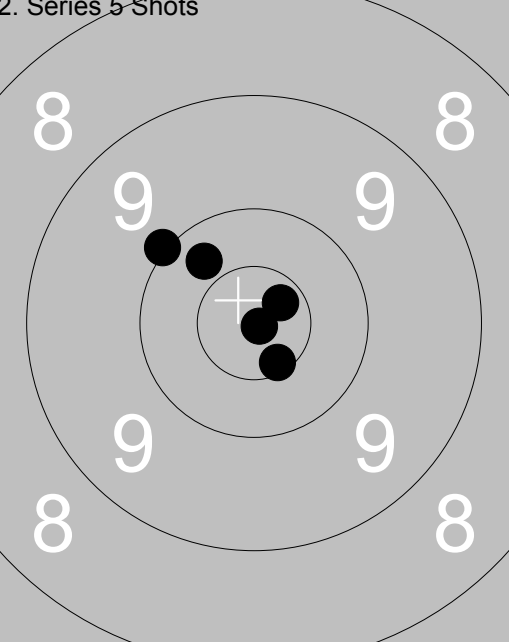
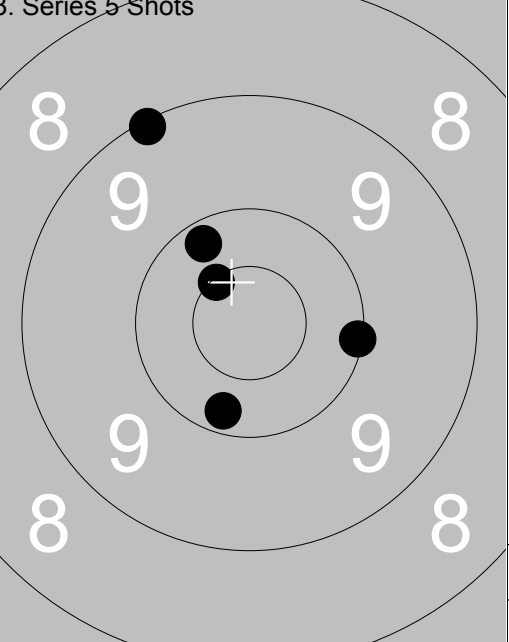
<p>2. Series 5 Shots</p> 	<p>1: 10.3 ↖ 2: *10.9 → 3: *10.6 ↘ 4: *10.7 ↗ 5: 10.0 ↖</p>	<p>3. Series 5 Shots</p> 		<p>1: 9.1 ↖ 2: 10.2 ↓ 3: *10.5 ↖ 4: 10.2 ↖ 5: 10.1 →</p>	
Series 50.0				Series 49.0	
Total 98.0				Total 147.0	

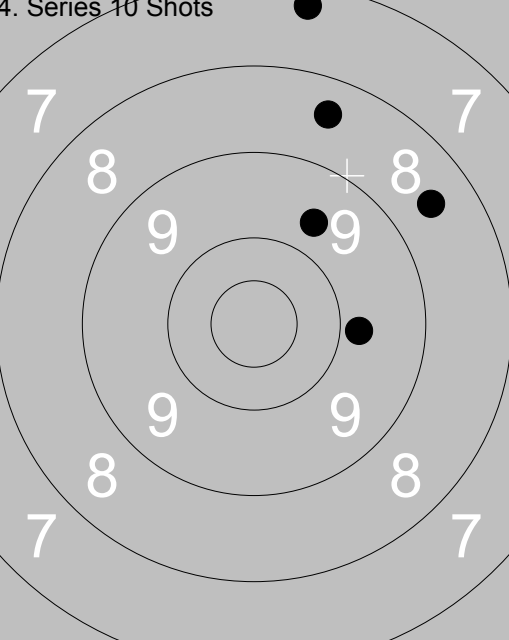
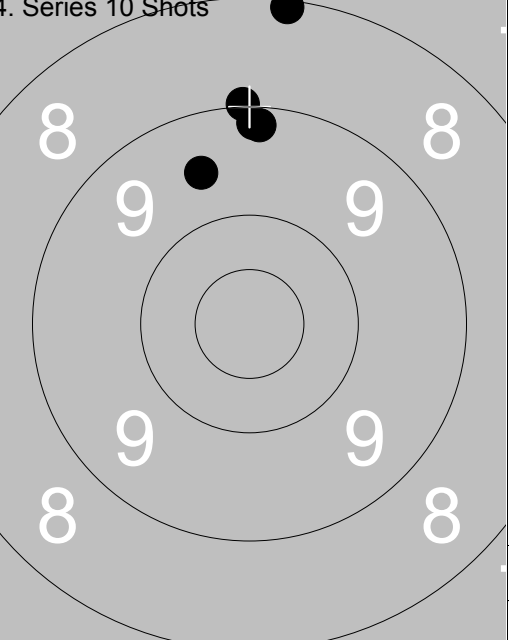
<p>4. Series 10 Shots</p> 	<p>1: 8.4 ↗ 2: 9.7 ↗ 3: 7.3 ↗ 4: 8.5 ↗ 5: 9.8 →</p>	<p>4. Series 10 Shots</p> 		<p>6: 9.6 ↗ 7: 9.2 ↗ 8: 9.2 ↗ 9: 8.1 ↗ 10: 9.0 ↗</p>	
Series 41.0				Series 44.0	
Total 188.0				Total 232.0	

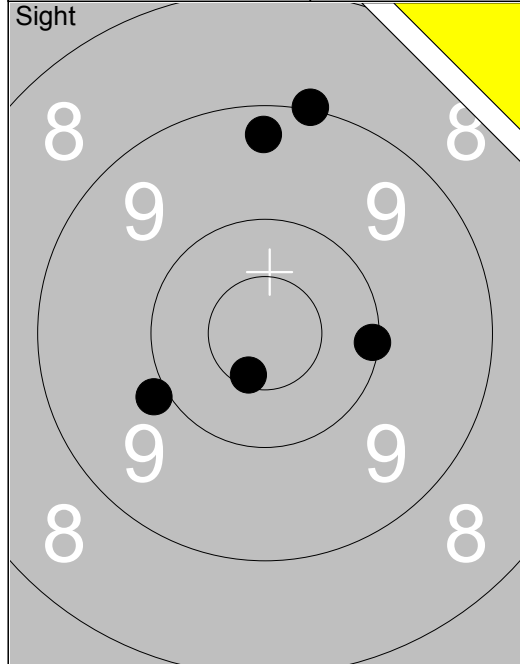

1:	9.9	↙
2:	9.0	↑
3:	9.3	↑
4:	10.1	→
5:	*10.6	↘
Series		47.0
Total		0.0

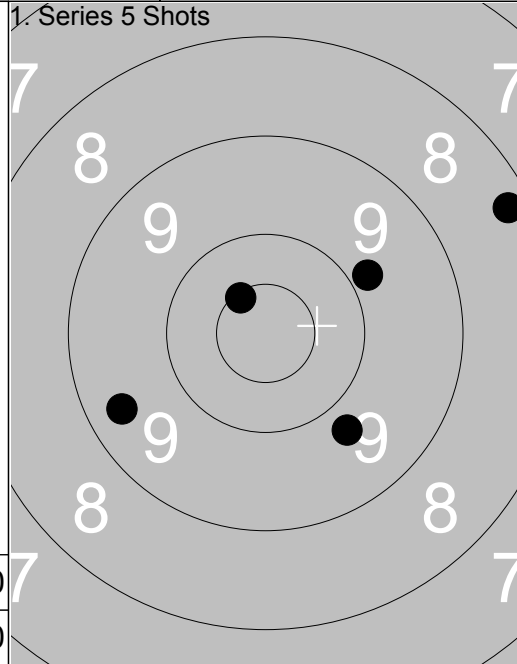

1:	9.4	↙
2:	*10.5	↗
3:	9.8	↗
4:	9.7	↘
5:	8.3	↗
Series		45.0
Total		45.0

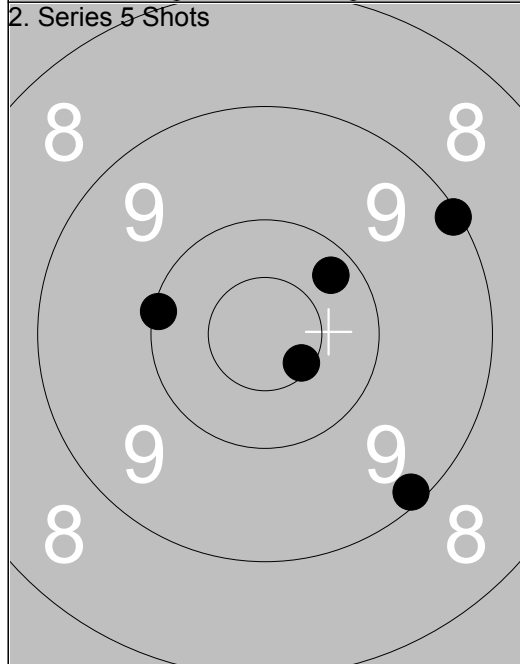

1:	10.1	↙
2:	10.2	↗
3:	9.1	↗
4:	*10.6	↘
5:	9.1	↘
Series		48.0
Total		93.0

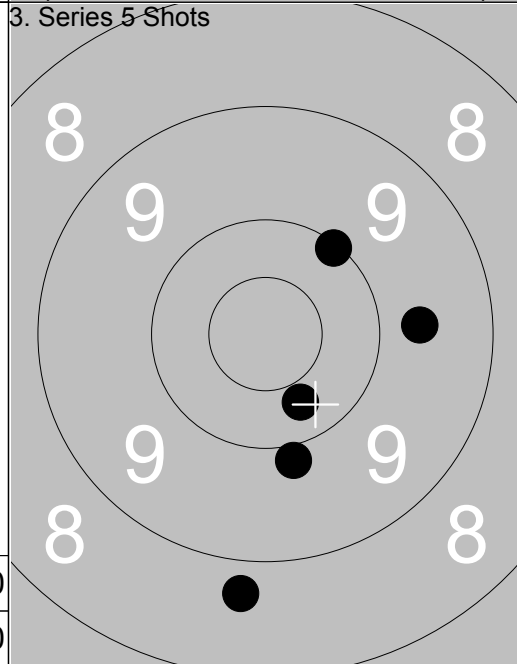

1:	10.3	↘
2:	10.1	↗
3:	9.7	→
4:	9.9	↘
5:	8.7	↘
Series		46.0
Total		139.0

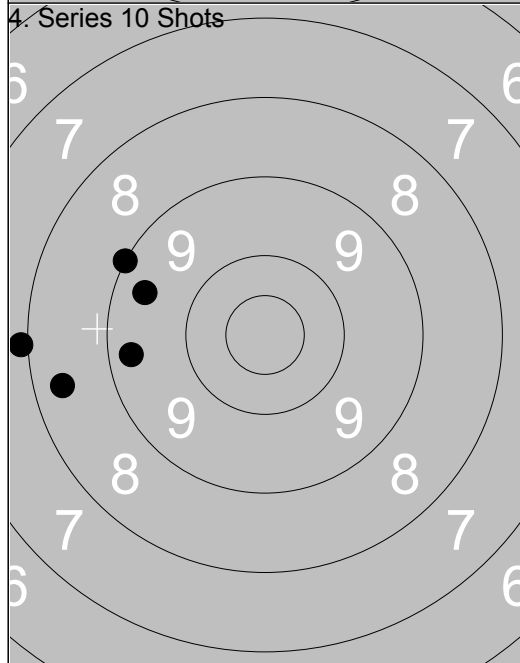

1:	9.4	↙
2:	8.4	↙
3:	9.3	↙
4:	9.0	↙
5:	7.9	↙
Series		42.0
Total		181.0

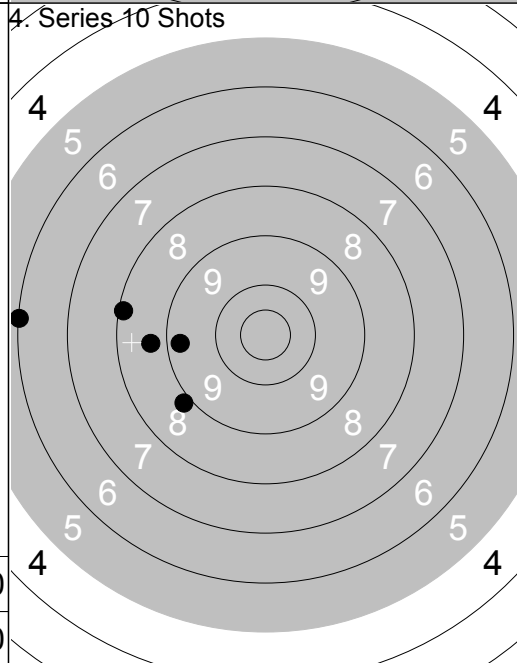

6:	6.0	↙
7:	9.3	↙
8:	8.7	↙
9:	8.9	↙
10:	8.1	↙
Series		39.0
Total		220.0

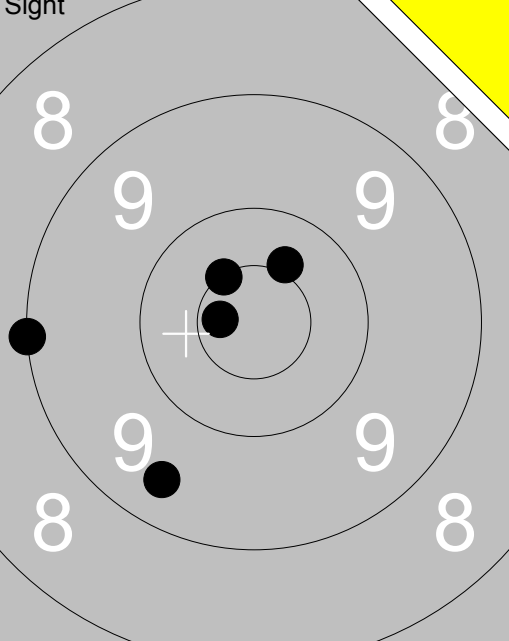
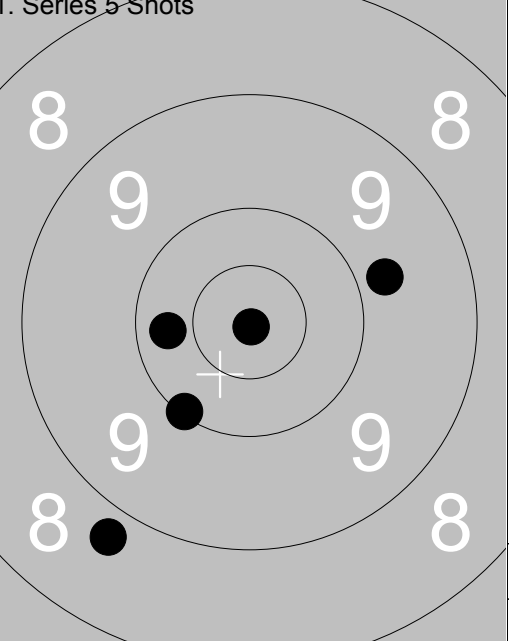
<p>Sight</p> 	<p>1. Series 5 Shots</p> 	
1: 9.4 ↙ 2: *10.5 ↘ 3: 9.0 ← 4: *10.7 ↗ 5: *10.4 ↗	1: 10.1 ↙ 2: 8.8 ↙ 3: *10.9 ↘ 4: 9.8 → 5: 10.3 ←	
Series 48.0 Total 0.0	Series 47.0 Total 47.0	

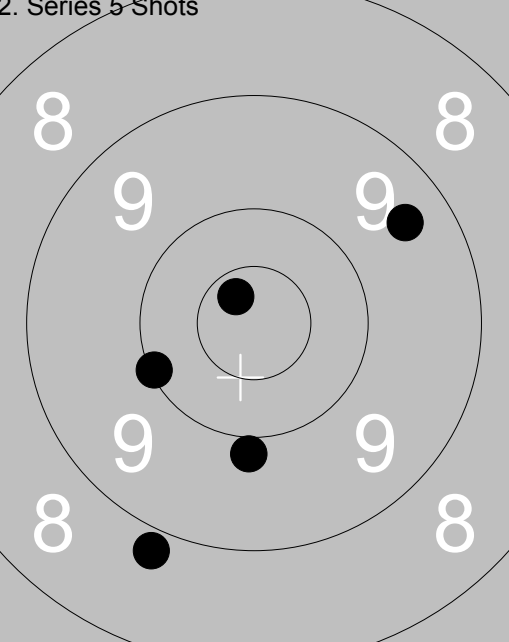
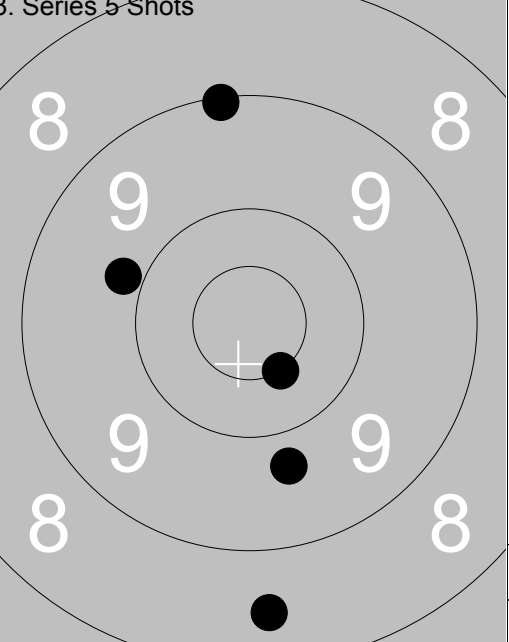
<p>2. Series 5 Shots</p> 	<p>3. Series 5 Shots</p> 	
1: 8.8 ↙ 2: 9.4 → 3: *10.7 ↗ 4: 9.9 ↘ 5: 10.1 ←	1: 8.5 ↘ 2: 9.1 ↗ 3: 9.9 ← 4: *10.5 ↘ 5: 9.7 ↘	
Series 46.0 Total 93.0	Series 45.0 Total 138.0	

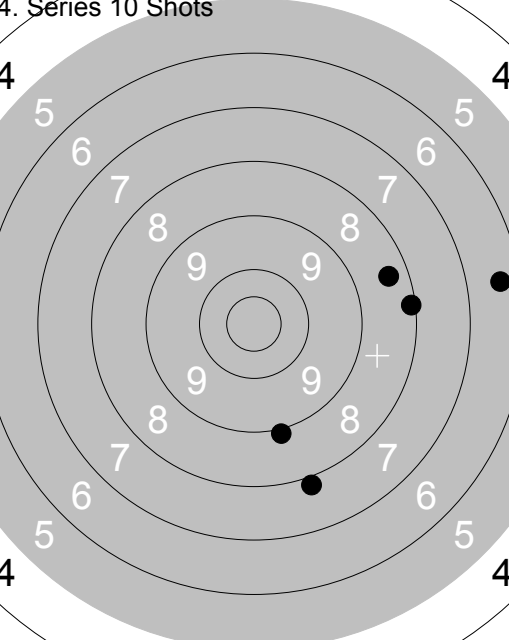
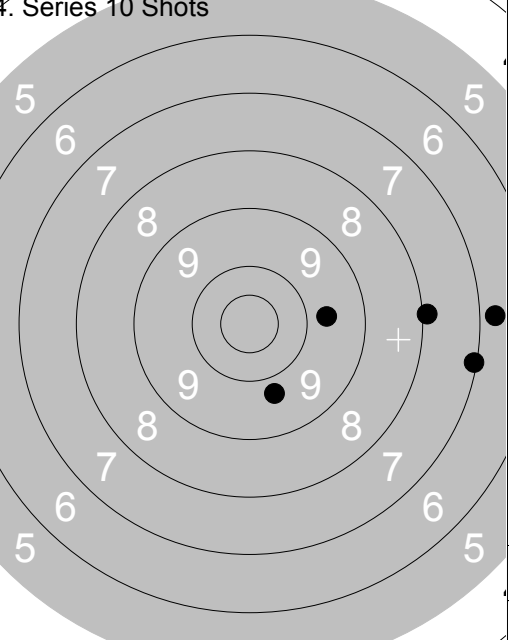
<p>4. Series 10 Shots</p> 	<p>4. Series 10 Shots</p> 	
1: 7.9 ↘ 2: 8.4 → 3: 8.1 → 4: 8.9 ↘ 5: 6.4 →	6: 7.1 → 7: 6.8 → 8: 9.8 ↘ 9: 7.9 → 10: 9.7 →	
Series 37.0 Total 175.0	Series 38.0 Total 213.0	

Relay **3** Lane **9** **Linda Bergman**

300m Ununge B St

06.07.2014 Tavelträffen 2014 Ramselefors SKF

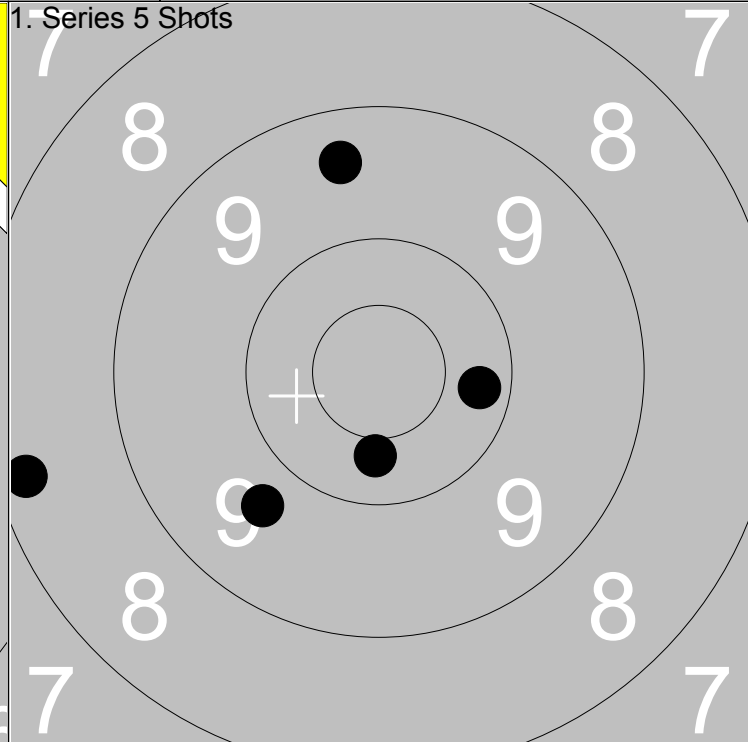
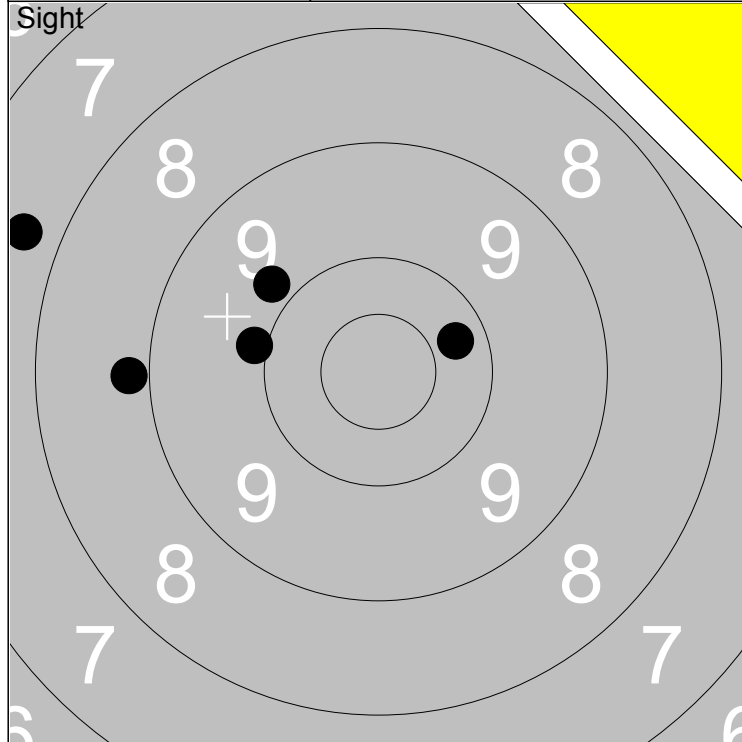

1: 7.7 ←	Series 43.0
2: 9.9 ←	
3: 9.8 ↖	
4: 8.9 ←	
5: 10.3 →	
Total 0.0	

1: 9.4 ↑	Series 46.0
2: 9.7 ↙	
3: 10.2 →	
4: 10.4 ↓	
5: 8.3 ←	
Total 46.0	

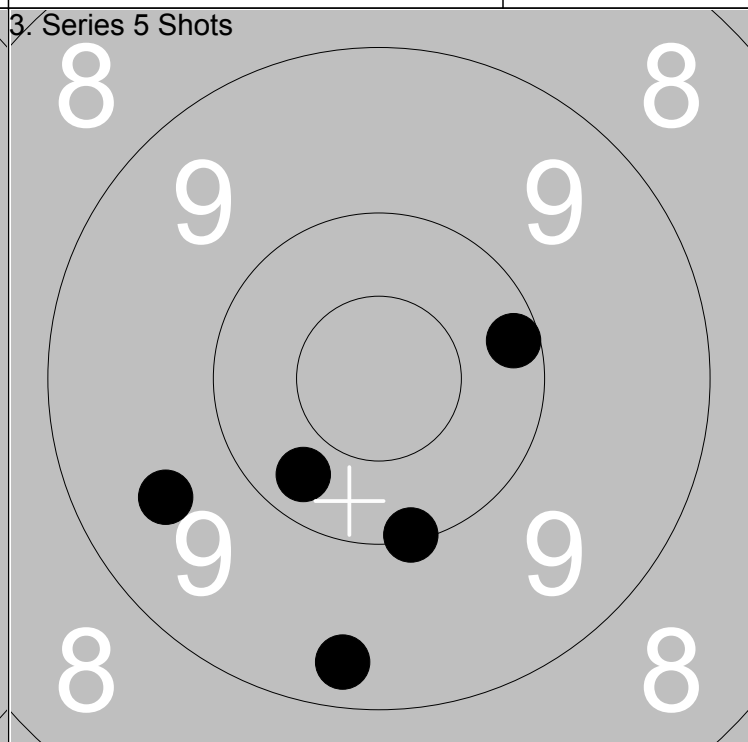
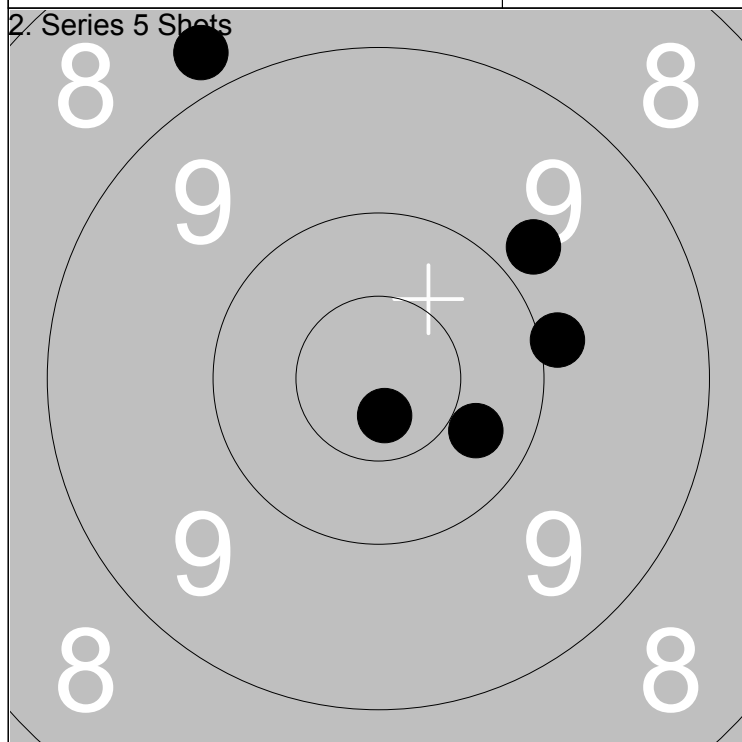

1: 8.8 ↖	Series 46.0
2: 9.8 ↗	
3: 10.3 ↘	
4: 9.9 →	
5: *10.7 ↓	
Total 92.0	

1: 10.2 →	Series 48.0
2: 9.6 ↙	
3: 10.3 ↘	
4: 10.1 ↓	
5: 9.3 ↓	
Total 140.0	

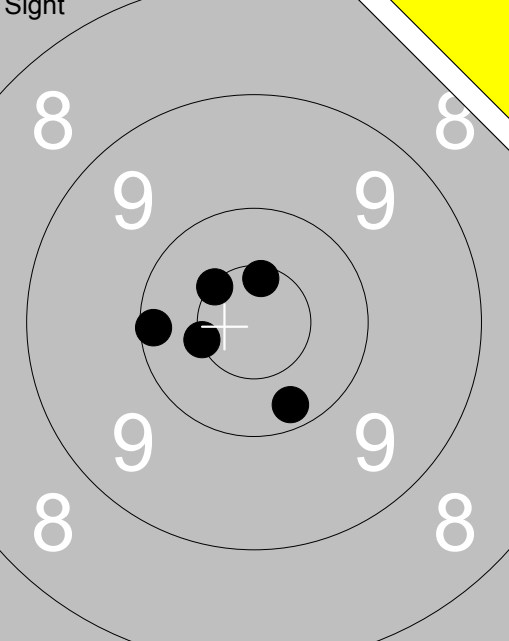
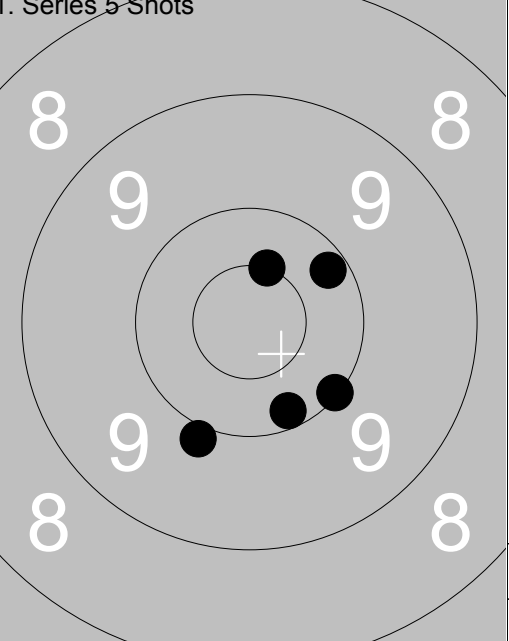
<p>Sight</p>  <p>Series 50.0 Total 0.0</p>	<p>1: *10.6↑ 2: *10.5↘ 3: *10.5↙ 4: 10.1← 5: 10.2↓</p>	<p>1. Series 5 Shots</p>  <p>Series 49.0 Total 49.0</p>		<p>1: *10.5↑ 2: 10.0↘ 3: 9.9 ↓ 4: 10.2↗ 5: 10.2 ↓</p>
--	--	---	--	---

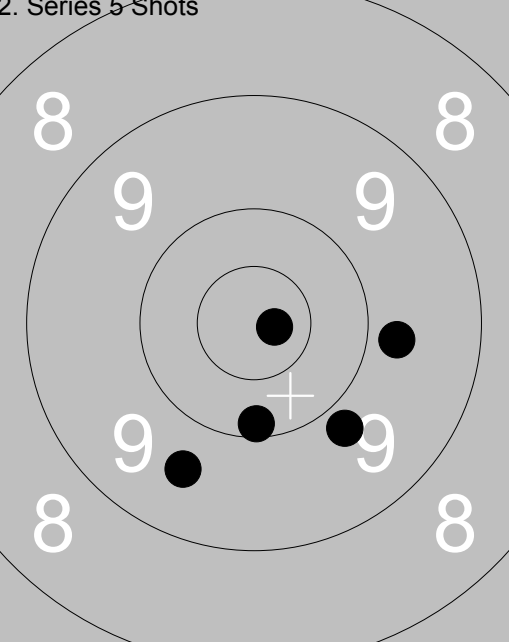
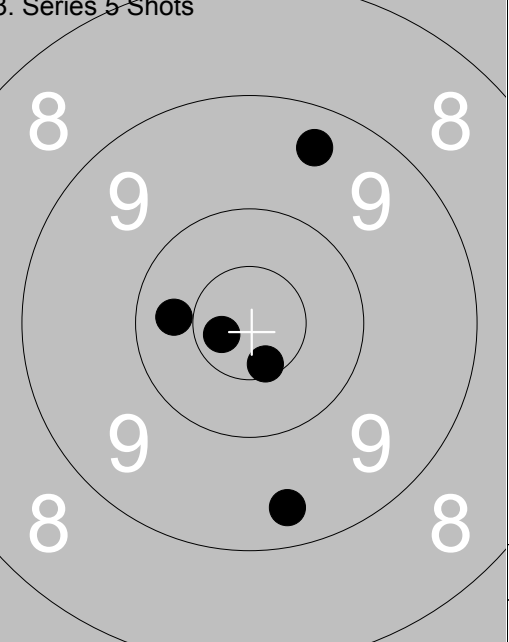
<p>2. Series 5 Shots</p>  <p>Series 47.0 Total 96.0</p>	<p>1: *10.8→ 2: 10.1 ↓ 3: 9.8 → 4: 9.8 ↘ 5: 9.6 ↓</p>	<p>3. Series 5 Shots</p>  <p>Series 48.0 Total 144.0</p>		<p>1: 9.4 ↑ 2: 9.4 ↓ 3: *10.6↓ 4: *10.7↙ 5: 10.3←</p>
--	---	---	--	---

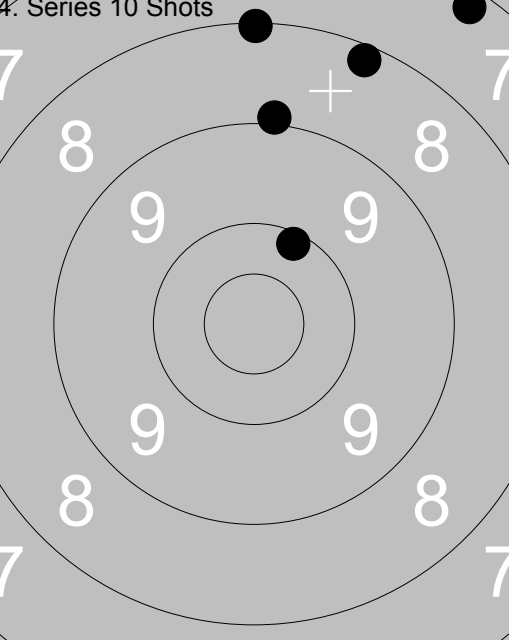
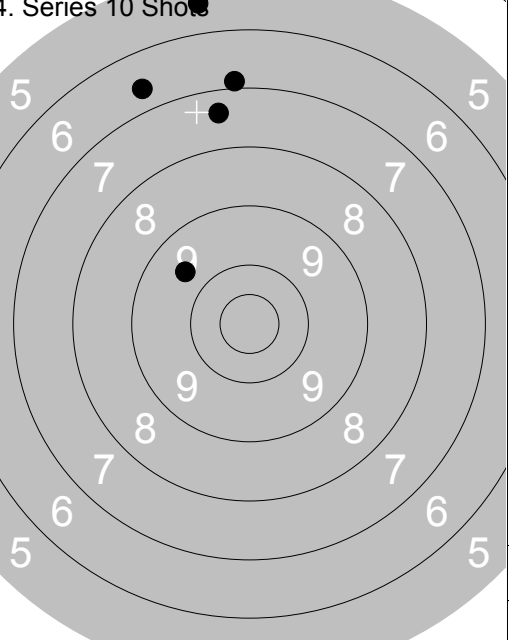
<p>4. Series 10 Shots</p>  <p>Series 42.0 Total 186.0</p>	<p>1: 9.0 ↑ 2: 10.1 ↑ 3: 8.1 ↑ 4: 8.2 ↑ 5: 7.2 ↑</p>	<p>4. Series 10 Shots</p>  <p>Series 33.0 Total 219.0</p>		<p>6: 5.5 ↑ 7: 9.6 ↘ 8: 7.4 ↑ 9: 6.9 ↑ 10: 6.6 ↘</p>
---	--	---	--	--

	<p>1: 10.1 ↙ 2: 10.4 ↘ 3: 9.6 ↘ 4: 9.4 ↗ 5: 9.2 →</p>	<p>1. Series 5 Shots</p>	<p>1: 9.2 ↗ 2: 8.8 ↘ 3: 10.3 ↖ 4: 10.2 ↗ 5: 8.3 ↖</p>
Series 47.0	7	Series 45.0	7
Total 0.0	7	Total 45.0	7

<p>2. Series 5 Shots</p>	<p>1: *10.6 ↗ 2: 8.9 ↖ 3: *10.4 ↗ 4: 10.3 → 5: 10.2 ↘</p>	<p>3. Series 5 Shots</p>	<p>1: 10.4 ↖ 2: *10.5 ↖ 3: 10.2 ↖ 4: 9.1 ↘ 5: 9.8 ↖</p>
Series 48.0	7	Series 48.0	7
Total 93.0	7	Total 141.0	7

<p>4. Series 10 Shots</p>	<p>1: 9.1 ↗ 2: 8.3 ↖ 3: 8.6 ↗ 4: 8.2 ↗ 5: 7.1 ↖</p>	<p>4. Series 10 Shots</p>	<p>6: 8.0 ↖ 7: 7.6 ↗ 8: 8.3 ↗ 9: 7.1 ↖ 10: 9.2 ↖</p>
Series 40.0	7	Series 39.0	7
Total 181.0	7	Total 220.0	7

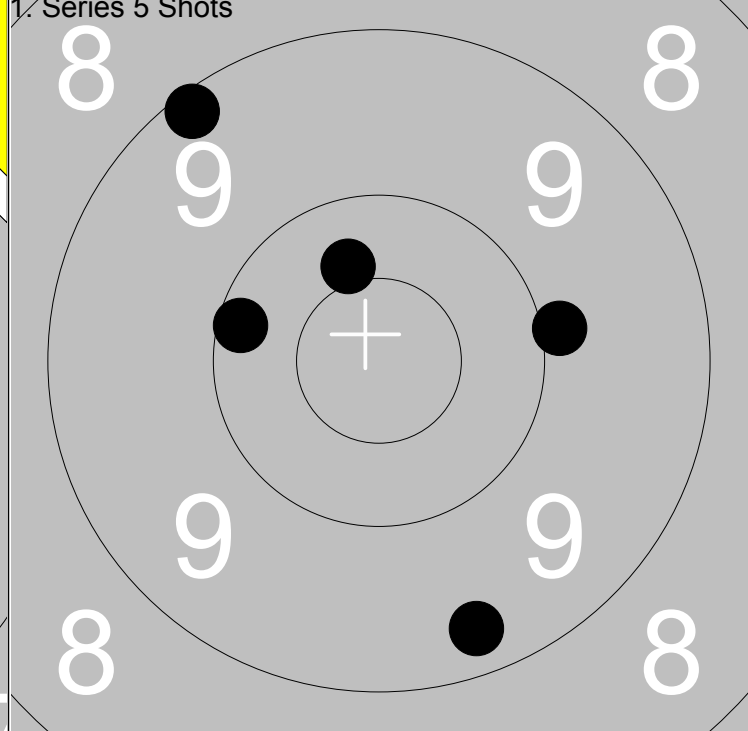
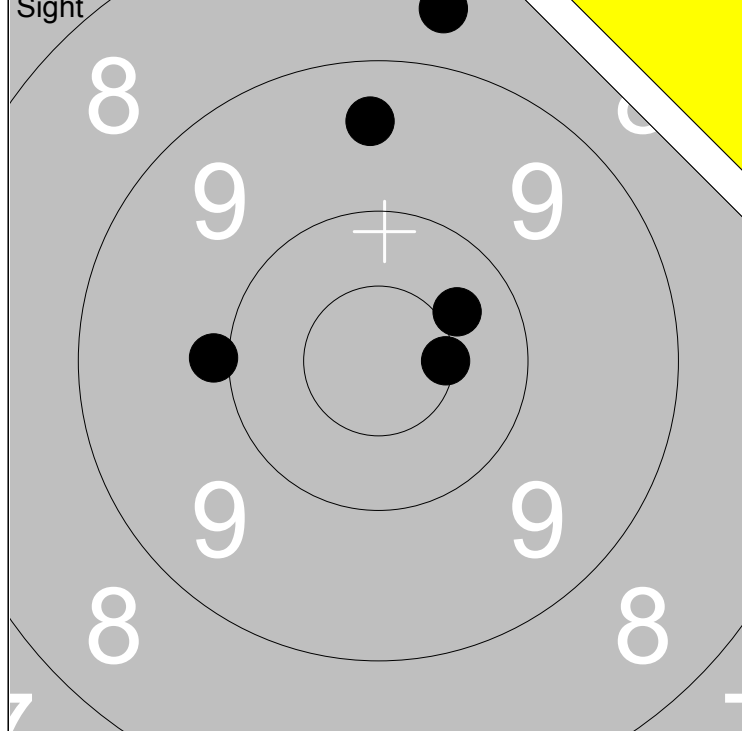

1: 9.9 ←	Series 46.0
2: 9.4 ↑	
3: 8.6 ↑	
4: 10.4 ↗	
5: *10.5 →	
Total 0.0	

1: 9.9 →	Series 47.0
2: 9.1 ↖	
3: 10.2 ←	
4: 10.4 ↑	
5: 9.3 ↓	
Total 47.0	

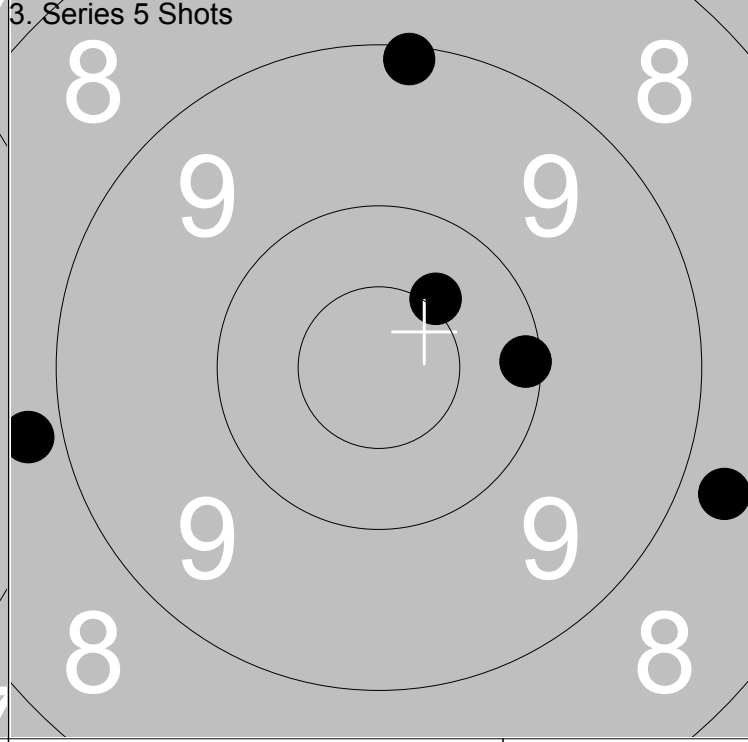
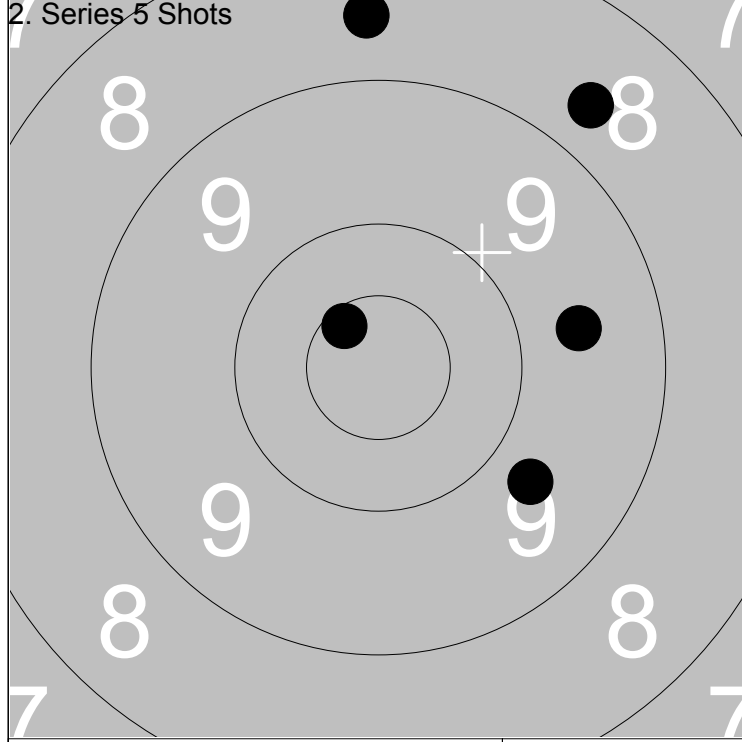

1: *10.6 ↖	Series 44.0
2: 8.6 ↑	
3: 9.7 ↘	
4: 8.7 ↗	
5: 9.6 →	
Total 91.0	

1: 8.8 →	Series 45.0
2: 8.8 ←	
3: 10.1 →	
4: 9.1 ↑	
5: *10.4 ↗	
Total 136.0	

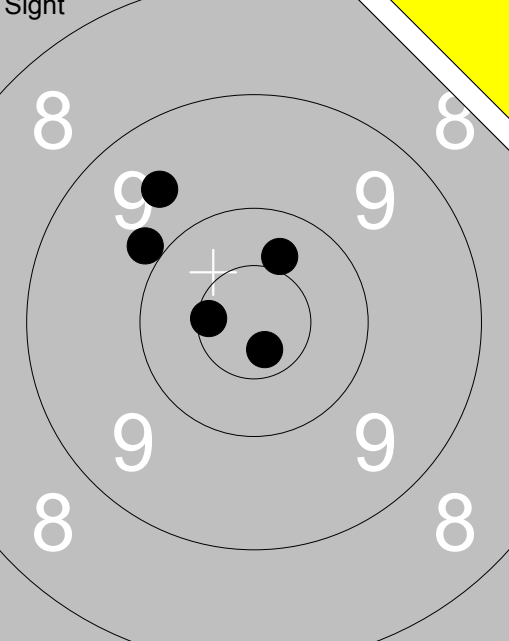
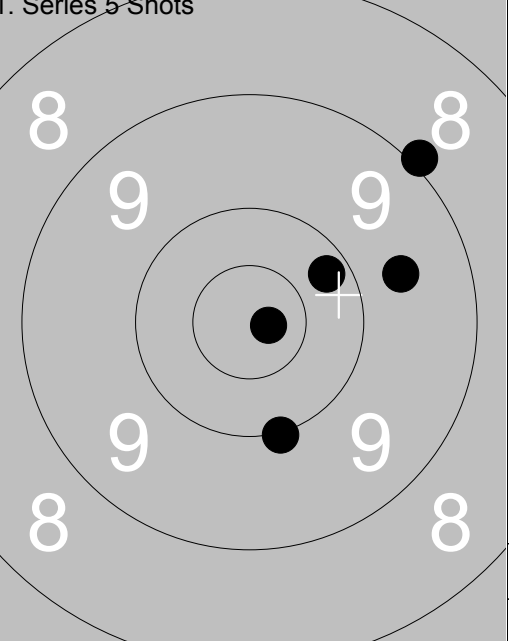
<p>Sight</p>  <p>1: *10.6 ← 2: 9.9 ↖ 3: 9.6 ↖ 4: 10.4 ↗ 5: *10.7 ↓</p> <table border="1" style="width:100%; border-collapse: collapse;"> <tr><td style="text-align:right;">Series</td><td style="text-align:left;">48.0</td></tr> <tr><td style="text-align:right;">Total</td><td style="text-align:left;">0.0</td></tr> </table>	Series	48.0	Total	0.0	<p>1. Series 5 Shots</p>  <p>1: 10.0 ↓ 2: *10.8 → 3: 10.2 ↗ 4: 9.0 ↗ 5: 9.6 →</p> <table border="1" style="width:100%; border-collapse: collapse;"> <tr><td style="text-align:right;">Series</td><td style="text-align:left;">48.0</td></tr> <tr><td style="text-align:right;">Total</td><td style="text-align:left;">48.0</td></tr> </table>	Series	48.0	Total	48.0
Series	48.0								
Total	0.0								
Series	48.0								
Total	48.0								

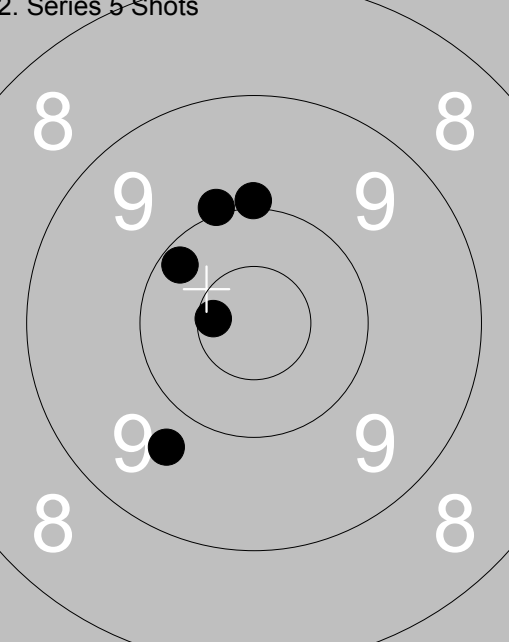
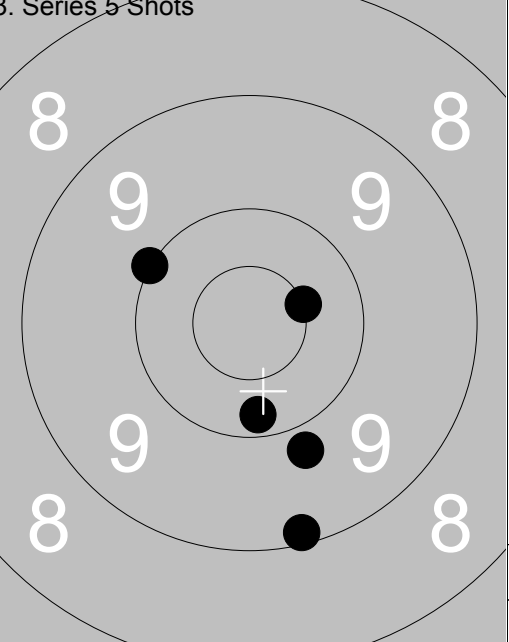
<p>2. Series 5 Shots</p>  <p>1: 10.2 ↖ 2: 10.0 ↗ 3: 10.0 ↗ 4: *10.6 ← 5: 9.7 ↓</p> <table border="1" style="width:100%; border-collapse: collapse;"> <tr><td style="text-align:right;">Series</td><td style="text-align:left;">49.0</td></tr> <tr><td style="text-align:right;">Total</td><td style="text-align:left;">97.0</td></tr> </table>	Series	49.0	Total	97.0	<p>3. Series 5 Shots</p>  <p>1: 10.0 ↖ 2: 9.8 ↓ 3: 10.2 ↓ 4: *10.5 → 5: 9.1 ↓</p> <table border="1" style="width:100%; border-collapse: collapse;"> <tr><td style="text-align:right;">Series</td><td style="text-align:left;">48.0</td></tr> <tr><td style="text-align:right;">Total</td><td style="text-align:left;">145.0</td></tr> </table>	Series	48.0	Total	145.0
Series	49.0								
Total	97.0								
Series	48.0								
Total	145.0								

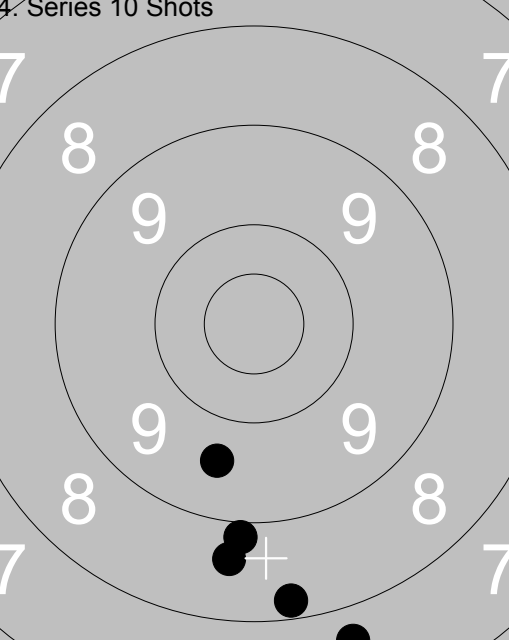
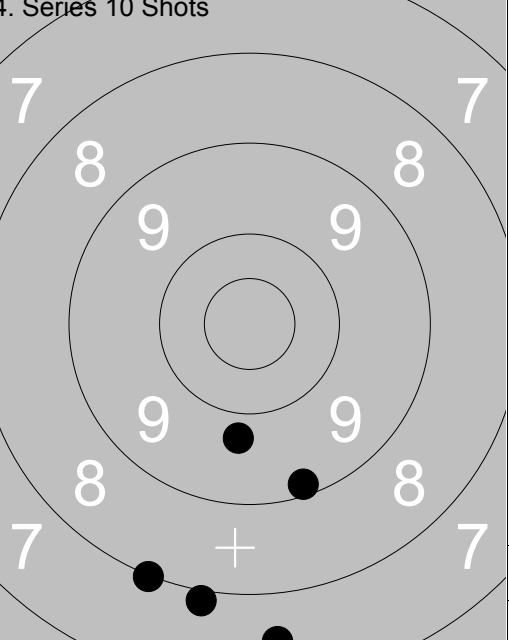
<p>4. Series 10 Shots</p>  <p>1: 8.6 ↓ 2: 8.2 ↓ 3: 7.7 ↓ 4: 8.9 ↓ 5: 9.6 ↓</p> <table border="1" style="width:100%; border-collapse: collapse;"> <tr><td style="text-align:right;">Series</td><td style="text-align:left;">40.0</td></tr> <tr><td style="text-align:right;">Total</td><td style="text-align:left;">185.0</td></tr> </table>	Series	40.0	Total	185.0	<p>4. Series 10 Shots</p>  <p>6: 9.8 ↓ 7: 8.0 ↓ 8: 7.9 ↓ 9: 9.2 ↓ 10: 7.5 ↓</p> <table border="1" style="width:100%; border-collapse: collapse;"> <tr><td style="text-align:right;">Series</td><td style="text-align:left;">40.0</td></tr> <tr><td style="text-align:right;">Total</td><td style="text-align:left;">225.0</td></tr> </table>	Series	40.0	Total	225.0
Series	40.0								
Total	185.0								
Series	40.0								
Total	225.0								

<p>Sight</p>	<p>1. Series 5 Shots</p>	
1: 10.4 → 2: 10.1 ↓ 3: 9.8 ↘ 4: 9.2 ↗ 5: 9.0 ↗	1: 10.1 ↖ 2: 8.8 ↙ 3: 9.0 ↗ 4: *10.6 ↘ 5: 8.9 ↓	
Series 47.0 Total 0.0	Series 45.0 Total 45.0	

<p>2. Series 5 Shots</p>	<p>3. Series 5 Shots</p>	
1: 8.6 ↓ 2: 10.2 ↗ 3: *10.7 ↘ 4: 9.7 ↘ 5: 10.2 ↗	1: 9.4 → 2: 10.2 ↗ 3: *10.5 ↗ 4: 8.4 → 5: 9.5 ↘	
Series 47.0 Total 92.0	Series 46.0 Total 138.0	

<p>4. Series 10 Shots</p>	<p>4. Series 10 Shots</p>	
1: 7.5 → 2: 8.3 ↗ 3: 7.2 ↗ 4: 7.2 ↗ 5: 9.8 →	6: 8.6 ↗ 7: 9.0 ↗ 8: 8.0 → 9: 9.5 → 10: 7.6 ↗	
Series 38.0 Total 176.0	Series 41.0 Total 217.0	

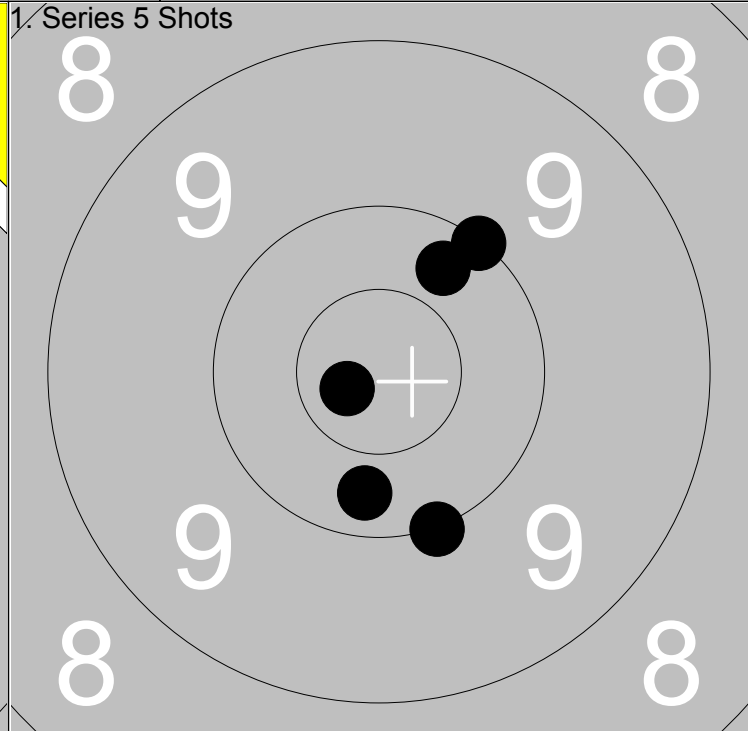
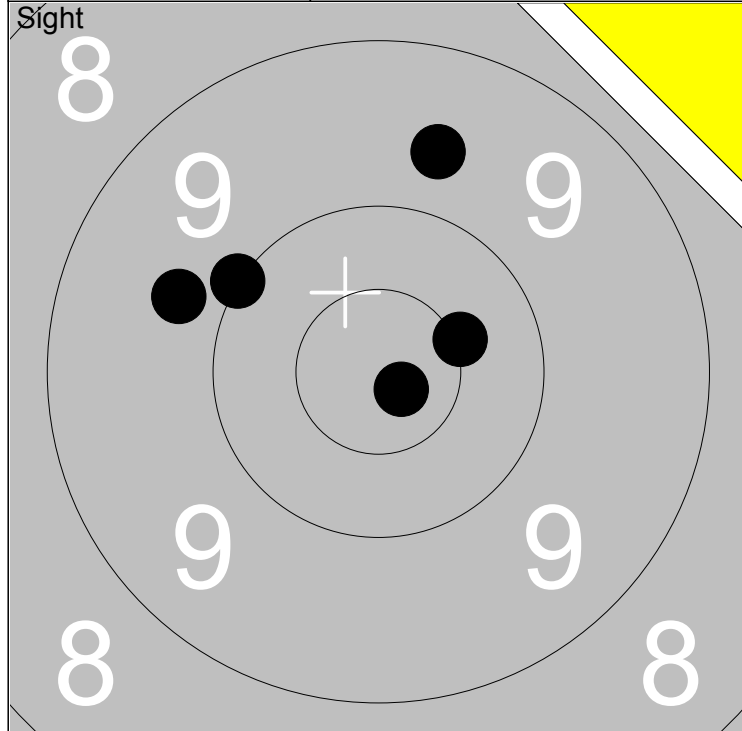

1: 9.7 ↙	Series	48.0
2: 10.0 ↖		
3: *10.5 →	Total	0.0
4: 9.7 ↑		
5: *10.8 ↘		

1: 10.3 ↗	Series	50.0
2: 10.0 ↗		
3: 10.3 ↓	Total	50.0
4: 10.0 ↓		
5: *10.7 ↙		

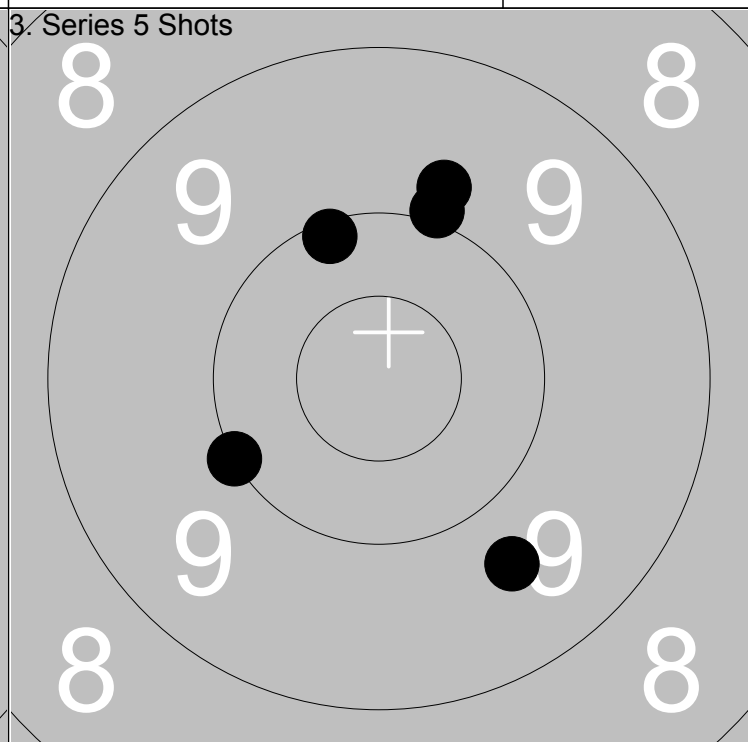
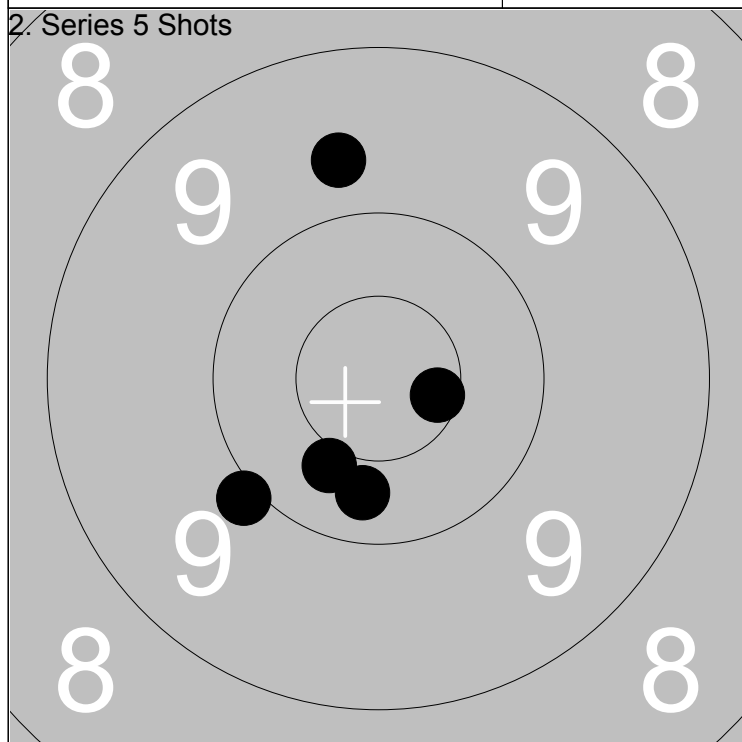

1: *10.6 →	Series	48.0
2: 9.9 ↙		
3: 10.3 ↓	Total	98.0
4: 10.4 ↙		
5: 9.7 ↑		

1: 9.8 ↑	Series	48.0
2: 10.0 ↙		
3: 10.0 ↑	Total	146.0
4: 10.1 ↑		
5: 9.7 ↘		

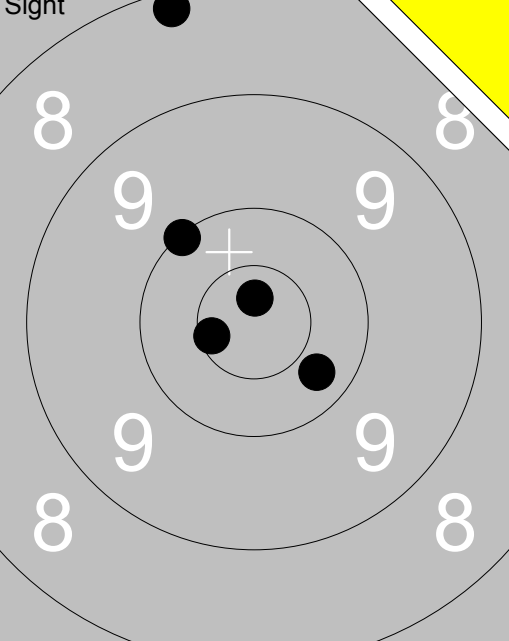
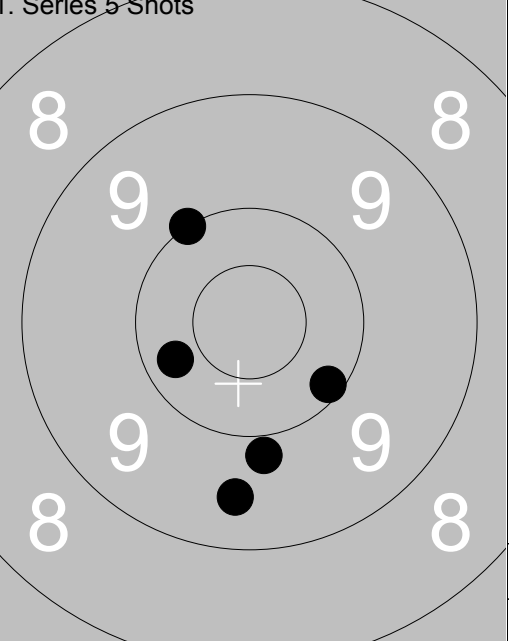
<p>Sight</p> 	<p>1. Series 5 Shots</p> 	<p>1: *10.8 ↑ 2: 10.0 ↖ 3: 10.3 ↘ 4: *10.6 ↖ 5: 8.2 ↑</p> <p>1: 10.1 ↘ 2: 10.0 ↖ 3: 10.3 ↙ 4: 9.9 ↓ 5: 9.5 ↓</p>
Series 48.0	Series 48.0	
Total 0.0	Total 48.0	

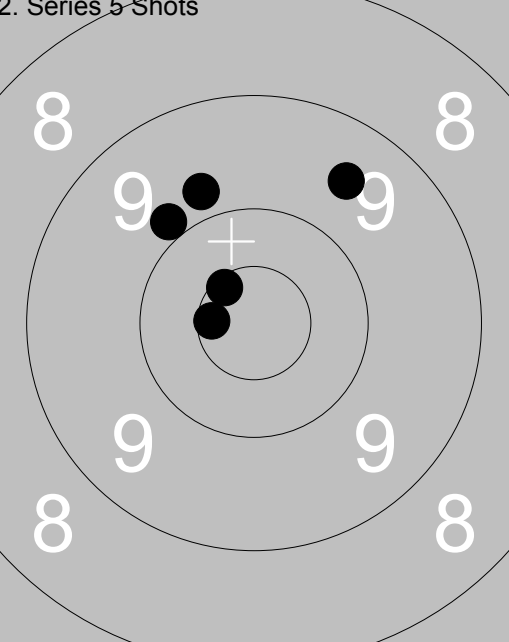
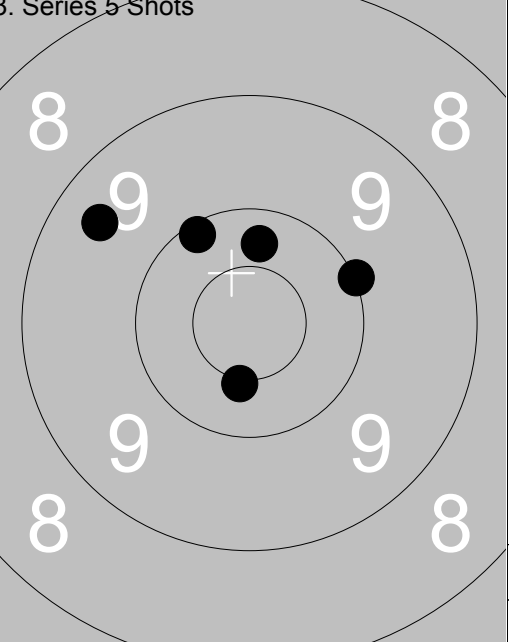
<p>2. Series 5 Shots</p> 	<p>3. Series 5 Shots</p> 	<p>1: *10.6 ↖ 2: 9.5 ↗ 3: 9.9 ↖ 4: *10.6 ↖ 5: 9.8 ↑</p> <p>1: 10.3 ↑ 2: 9.4 ↖ 3: 10.1 ↖ 4: 10.0 ↗ 5: *10.5 ↓</p>
Series 47.0	Series 49.0	
Total 95.0	Total 144.0	

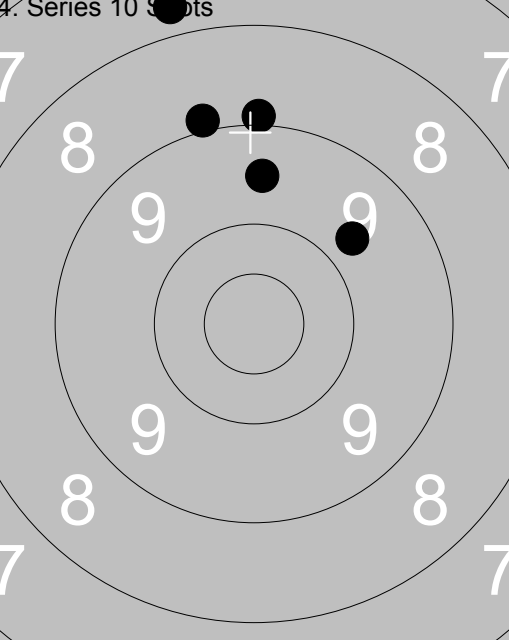
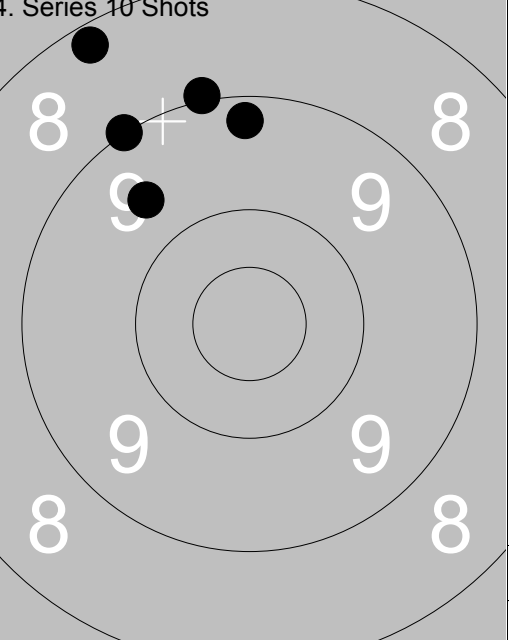
<p>4. Series 10 Shots</p> 	<p>4. Series 10 Shots</p> 	<p>1: 8.9 ↑ 2: 9.7 ↗ 3: 9.5 ↑ 4: 7.7 ↑ 5: 8.9 ↑</p> <p>6: 9.2 ↑ 7: 9.0 ↖ 8: 8.2 ↖ 9: 9.6 ↖ 10: 9.0 ↑</p>
Series 41.0	Series 44.0	
Total 185.0	Total 229.0	

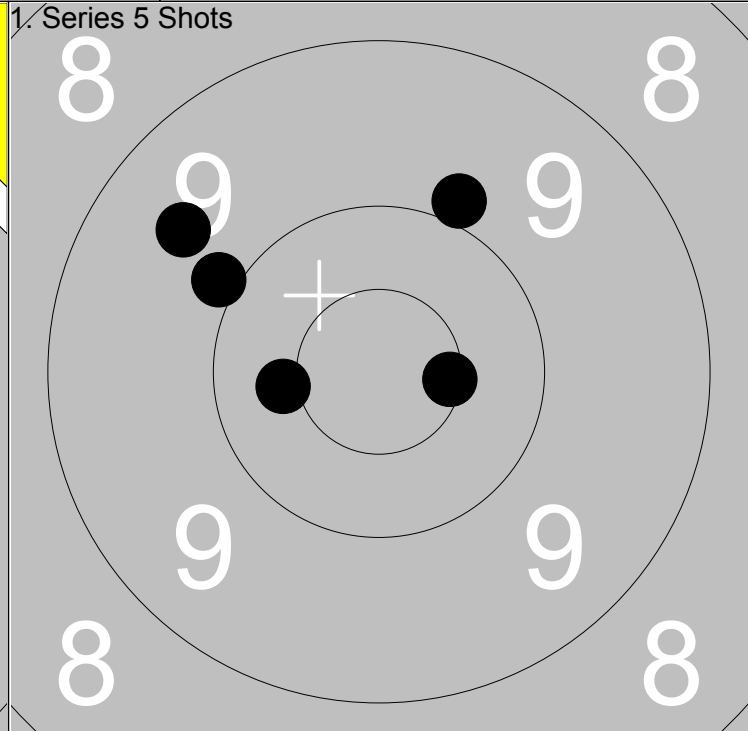
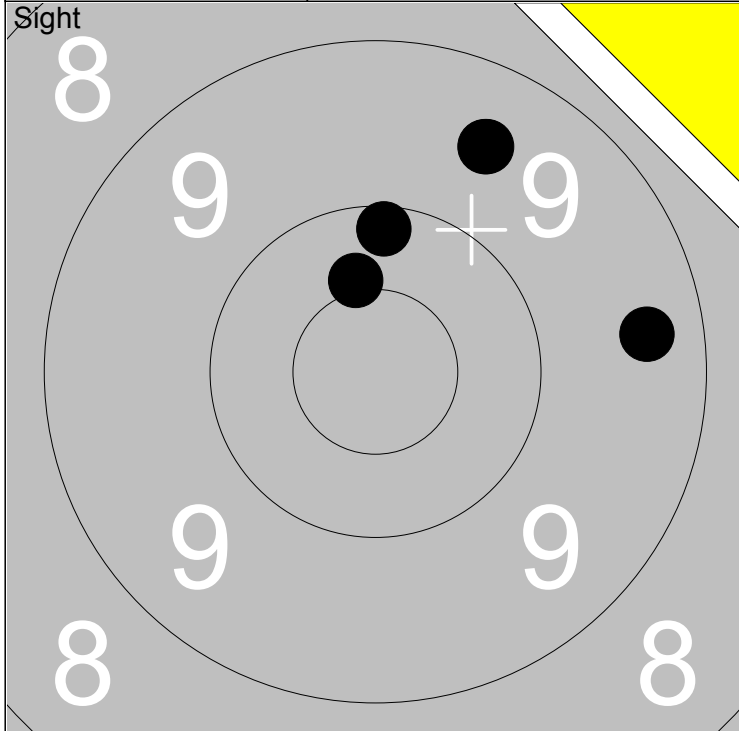

1: 9.5 ↗	Series	47.0
2: *10.4 ↗		
3: 9.5 ↗	Total	0.0
4: 10.2 ↗		
5: 9.4 →		

1: *10.5 →	Series	47.0
2: 9.6 ↖		
3: 9.9 ↗	Total	47.0
4: 10.4 ←		
5: 9.9 ↖		

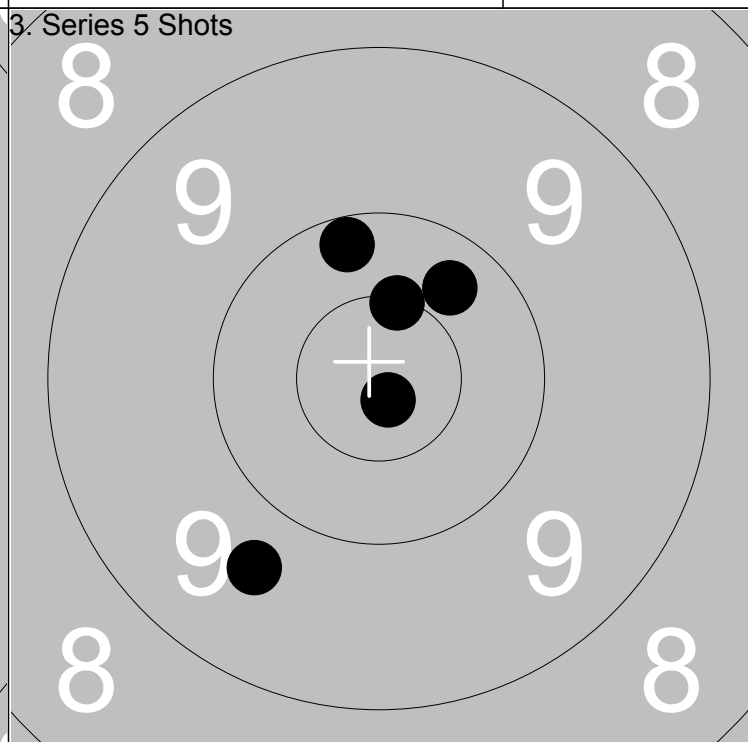
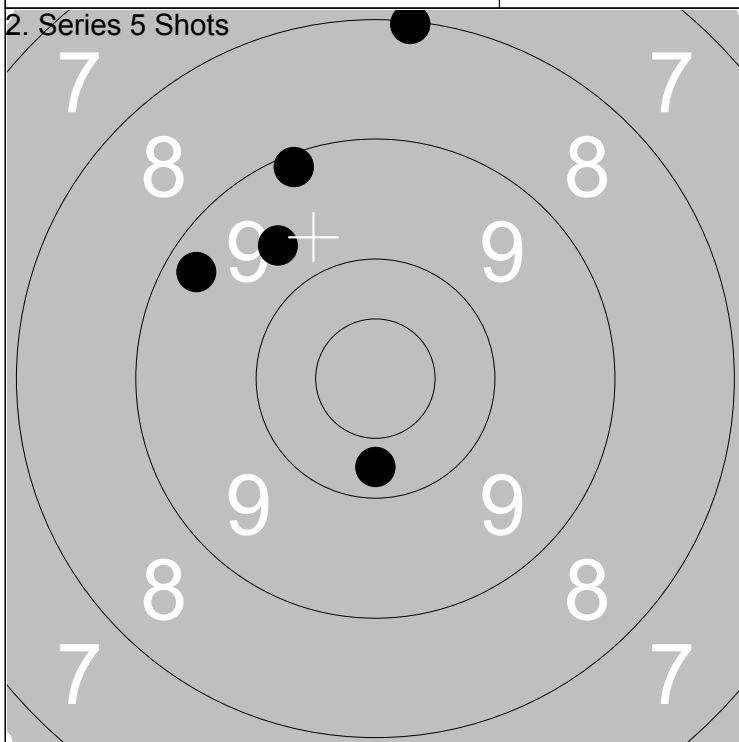

1: 8.1 ↗	Series	45.0
2: 9.3 ↖		
3: 9.1 ↗	Total	92.0
4: 10.3 ↓		
5: 9.7 ↖		

1: *10.5 ↗	Series	49.0
2: 9.7 ↘		
3: 10.3 ↗	Total	141.0
4: 10.2 ↗		
5: *10.8 ↓		

<p>Sight</p>	<p>1: 6.5 →</p> <p>2: 6.4 →</p> <p>3: 8.2 →</p> <p>4: 7.1 ↙</p> <p>5: 7.5 ←</p>	<p>1. Series 5 Shots</p>	<p>1: 9.1 ↑</p> <p>2: 7.7 ↓</p> <p>3: 8.6 ↓</p> <p>4: 7.5 ↖</p> <p>5: 9.3 ↖</p>
Series 34.0	Total 0.0	Series 40.0	Total 40.0

<p>2. Series 5 Shots</p>	<p>1: 8.3 ↓</p> <p>2: 8.6 ↓</p> <p>3: 8.3 ↑</p> <p>4: 7.6 ↗</p> <p>5: 7.0 ↗</p>	<p>3. Series 5 Shots</p>	<p>1: 8.8 ←</p> <p>2: 8.7 ↑</p> <p>3: 10.1 ↗</p> <p>4: 7.7 ↖</p> <p>5: 9.8 ↖</p>
Series 38.0	Total 78.0	Series 42.0	Total 120.0

<p>4. Series 10 Shots</p>	<p>1: 8.6 ↑</p> <p>2: 7.6 ↓</p> <p>3: 6.4 ↖</p> <p>4: 9.1 ←</p> <p>5: 6.9 ↗</p>	<p>4. Series 10 Shots</p>	<p>6: 8.1 ↑</p> <p>7: 7.7 ↖</p> <p>8: 9.5 ↗</p> <p>9: 7.8 →</p> <p>10: 10.3 ←</p>
Series 36.0	Total 156.0	Series 41.0	Total 197.0

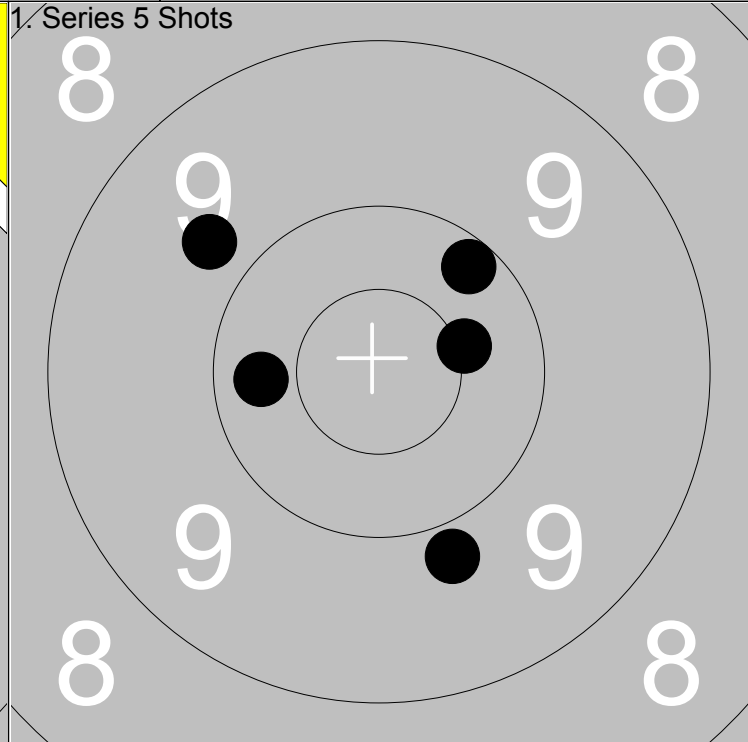
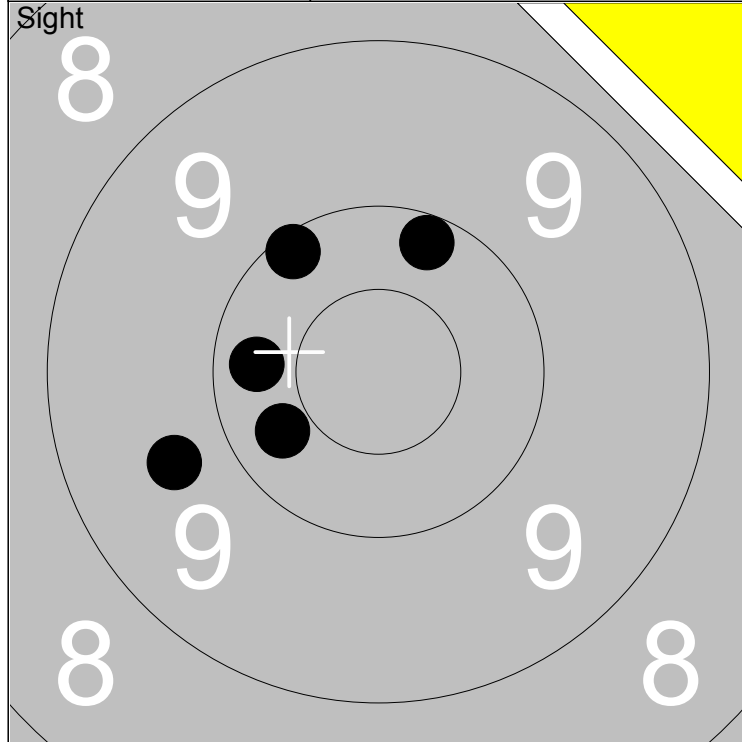

1: 10.3 ↙	Series	49.0
2: 10.1 ↖		
3: 10.2 ↗	Total	0.0
4: 9.7 ↙		
5: 10.3 ↙		

1: *10.4 ➔	Series	48.0
2: 9.7 ↖		
3: 10.2 ↗	Total	48.0
4: 10.3 ↙		
5: 9.8 ↓		

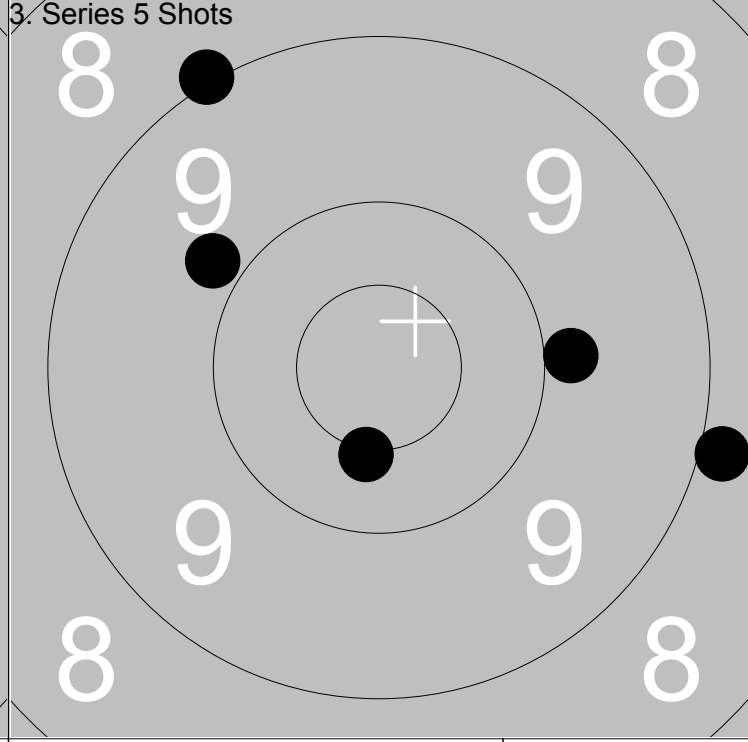
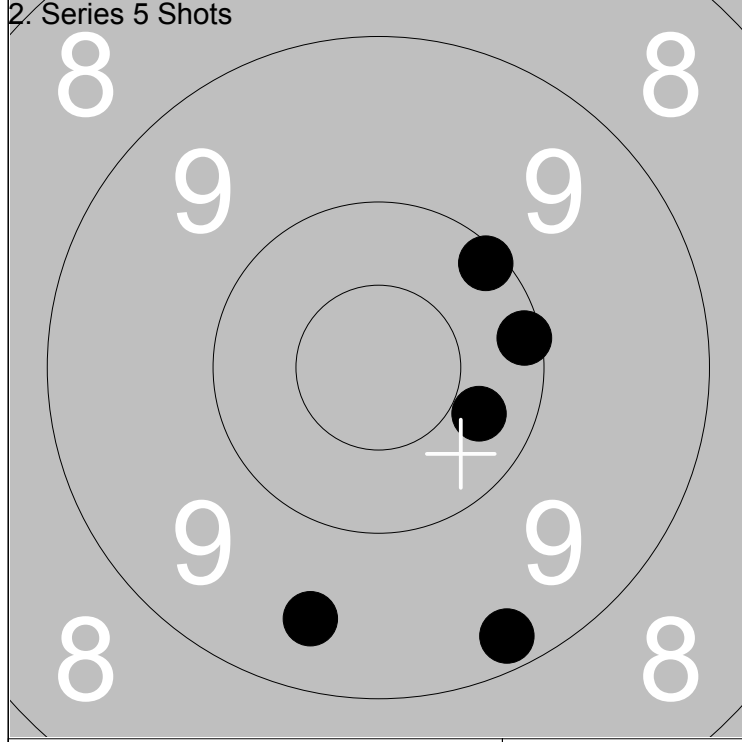

1: 10.3 ➔	Series	48.0
2: 10.1 ➔		
3: 9.5 ↓	Total	96.0
4: 9.2 ↓		
5: 10.1 ↗		

1: 8.9 ➔	Series	45.0
2: 9.9 ➔		
3: 9.8 ↖	Total	141.0
4: 9.0 ↗		
5: *10.5 ↓		

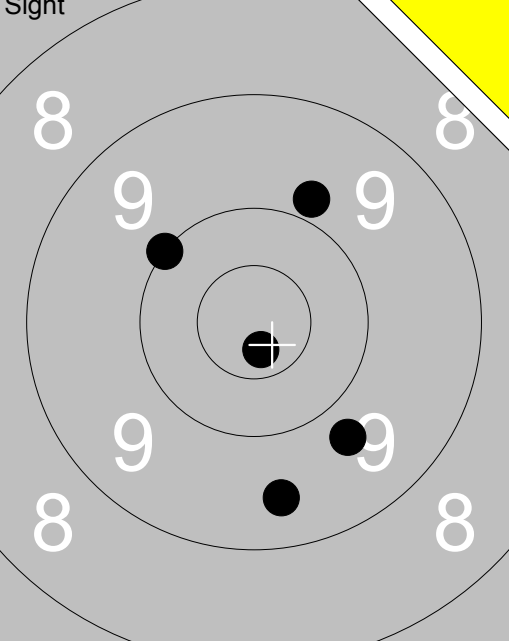
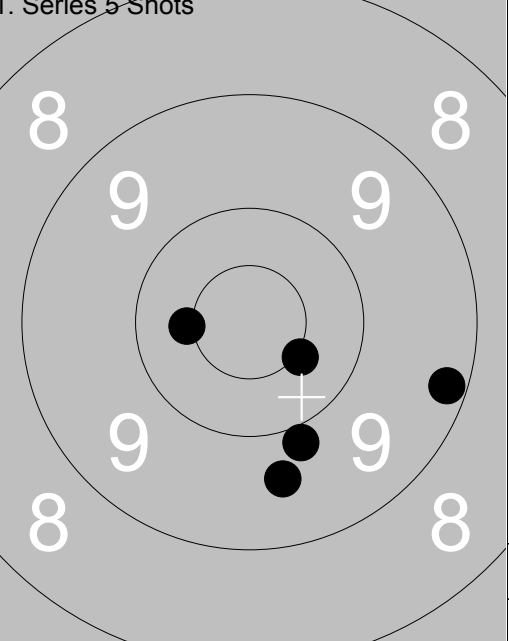
<p>Sight</p> 	<p>1: 9.7 ↘ 2: 9.5 ↓ 3: 10.0 ↙ 4: *10.7 ↓ 5: 9.8 ↗</p>	<p>1. Series 5 Shots</p> 		<p>1: *10.5 ↘ 2: *10.4 ← 3: 9.9 ↓ 4: 9.6 ↓ 5: 9.2 →</p>	
Series 47.0				Series 47.0	
Total 0.0				Total 47.0	

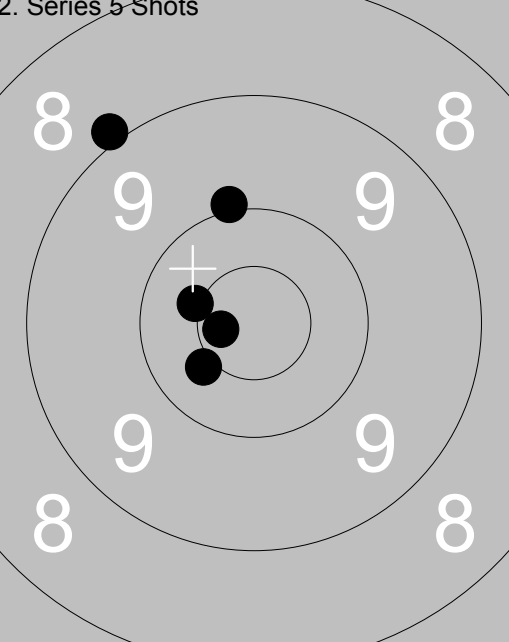
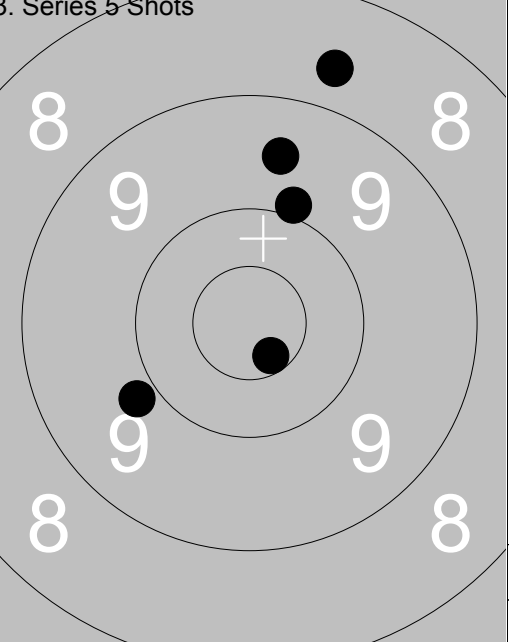
<p>2. Series 5 Shots</p> 	<p>1: 8.9 ↖ 2: 10.0 ↑ 3: *10.7 ↙ 4: *10.4 ← 5: 10.4 ↙</p>	<p>3. Series 5 Shots</p> 		<p>1: 8.7 ↗ 2: *10.6 ↘ 3: 9.8 ↙ 4: 9.9 ↑ 5: 9.5 ↑</p>	
Series 48.0				Series 45.0	
Total 95.0				Total 140.0	

<p>4. Series 10 Shots</p> 	<p>1: 8.2 ↗ 2: 9.2 ↗ 3: 8.5 → 4: 7.4 → 5: 9.8 →</p>	<p>4. Series 10 Shots</p> 		<p>6: 7.7 ↗ 7: 8.4 ↗ 8: 7.9 ↗ 9: 9.5 ↑ 10: 8.1 →</p>	
Series 41.0				Series 39.0	
Total 181.0				Total 220.0	