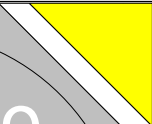
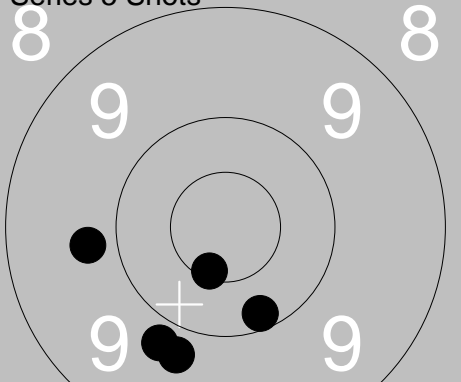
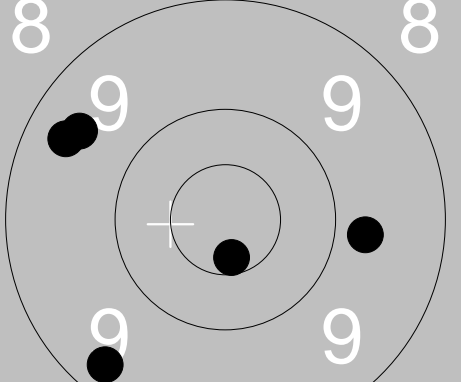
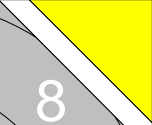
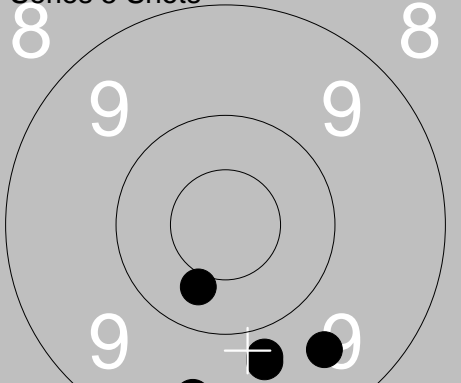

<p>5 Shots Sight</p>	<p>1: 9.3 ←</p> <p>2: 10.3 ↑</p> <p>3: *10.6 ↙</p> <p>4: *10.6 ↓</p> <p>5: *10.5 →</p>	<p>1. Series 5 Shots</p>	<p>1: 10.2 ↙</p> <p>2: 10.2 ↗</p> <p>3: 9.9 ←</p> <p>4: 10.4 ←</p> <p>5: *10.6 →</p>
Series 49.0		Series 49.0	
Total 0.0		Total 49.0	

<p>2. Series 5 Shots</p>	<p>1: 10.1 ←</p> <p>2: 9.9 ↗</p> <p>3: *10.8 ↘</p> <p>4: *10.5 ↓</p> <p>5: *10.8 ↗</p>	<p>3. Series 5 Shots</p>	<p>1: 9.0 ←</p> <p>2: *10.6 ←</p> <p>3: 10.1 ↗</p> <p>4: 7.3 ↗</p> <p>5: 9.4 →</p>
Series 49.0		Series 45.0	
Total 98.0		Total 143.0	

<p>Sight</p>	<p>1: 9.6 ←</p> <p>2: 10.2 ←</p> <p>3: *10.5 ↙</p>	<p>1. Series 5 Shots</p>	<p>1: 9.2 ↑</p> <p>2: *10.5 ↓</p> <p>3: 10.2 →</p> <p>4: 10.0 ↗</p> <p>5: *10.5 ↙</p>
Series 29.0		Series 49.0	
Total 143.0		Total 192.0	

<p>2. Series 5 Shots</p>	<p>1: 9.9 ↗</p> <p>2: 8.7 ↓</p> <p>3: 9.0 ↗</p> <p>4: 9.9 →</p> <p>5: 9.7 ←</p>		
Series 44.0			
Total 236.0			

Relay	Lane	Johan Nilsson	
300m		Ramselefors	SenB Vb
2013-07-06		Björkskottet 2013	Ramselefors SKF
5 Shots Sight		1: *10.5 ↘ 2: 10.2 → 3: 9.9 ↗ 4: 9.5 ↖ 5: 10.1 ↓	1. Series 5 Shots  1: 9.8 ← 2: *10.6 ↓ 3: 9.8 ↓ 4: 9.8 ↓ 5: 10.2 ↓
		Series 48.0	Series 47.0
		Total 0.0	Total 47.0
2. Series 5 Shots		1: 9.6 ↑ 2: 9.3 ↗ 3: 9.4 ↓ 4: 9.1 ↗ 5: 9.4 ←	3. Series 5 Shots  1: 9.5 ↖ 2: 9.4 ↖ 3: 9.3 ↓ 4: 9.8 → 5: *10.6 ↓
		Series 45.0	Series 46.0
		Total 92.0	Total 138.0
Sight		1: 7.5 ↘ 2: 9.5 ← 3: 9.4 ←	1. Series 5 Shots  1: 9.4 ↓ 2: 10.4 ↓ 3: 9.7 ↓ 4: 9.8 ↓ 5: 9.6 ↓
		Series 25.0	Series 46.0
		Total 138.0	Total 184.0
2. Series 5 Shots		1: 9.0 ↗ 2: 9.0 → 3: *10.5 → 4: 8.8 ← 5: 8.7 ↘	
		Series 44.0	
		Total 228.0	

<p>5 Shots Sight</p>	<p>1: 9.9 ↗ 2: 9.1 ↑ 3: 9.7 ↗ 4: 9.9 ↓ 5: 9.9 ↑</p>	<p>1. Series 5 Shots</p>	<p>1: 9.5 ↑ 2: 8.3 ↓ 3: 9.5 ↓ 4: 10.1 ↗ 5: 9.8 ↓</p>
Series 45.0		Series 45.0	
Total 0.0		Total 45.0	

<p>2. Series 5 Shots</p>	<p>1: 9.9 → 2: 10.1 ↓ 3: 9.3 ↓ 4: 9.7 ↓ 5: 7.8 ↓</p>	<p>3. Series 5 Shots</p>	<p>1: 9.2 → 2: 8.8 ↙ 3: *10.8 ↓ 4: 6.6 ↑ 5: *10.5 ↗</p>
Series 44.0		Series 43.0	
Total 89.0		Total 132.0	

<p>Sight</p>	<p>1: *10.6 ↗ 2: 8.0 ↖ 3: 8.6 ↙</p>	<p>1. Series 5 Shots</p>	<p>1: *10.7 ↙ 2: 9.9 → 3: 10.0 ↗ 4: 9.8 ↗ 5: 9.6 ↖</p>
Series 26.0		Series 47.0	
Total 132.0		Total 179.0	

<p>2. Series 5 Shots</p>	<p>1: 9.8 → 2: 8.7 ← 3: 9.5 ↙ 4: 9.2 ↗ 5: 9.3 ↓</p>		
Series 44.0			
Total 223.0			

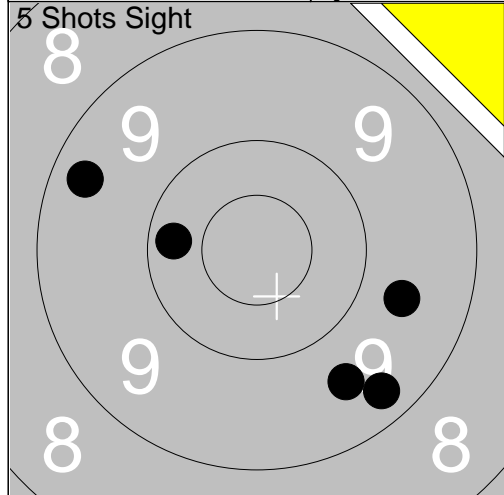

1:	10.2	←
2:	9.6	↓
3:	9.3	↘
4:	9.6	↗
5:	9.3	↗
Series		46.0
Total		0.0

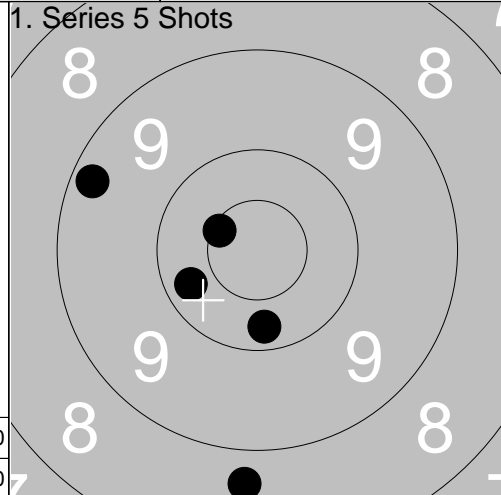

1:	10.3	←
2:	8.7	↓
3:	9.2	↖
4:	10.2	↓
5:	*10.6	↖
Series		47.0
Total		47.0

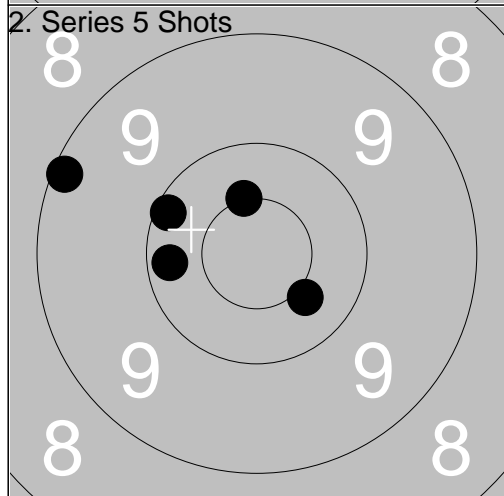

1:	10.4	↘
2:	10.2	←
3:	*10.5	↑
4:	9.1	↖
5:	10.1	↗
Series		49.0
Total		96.0

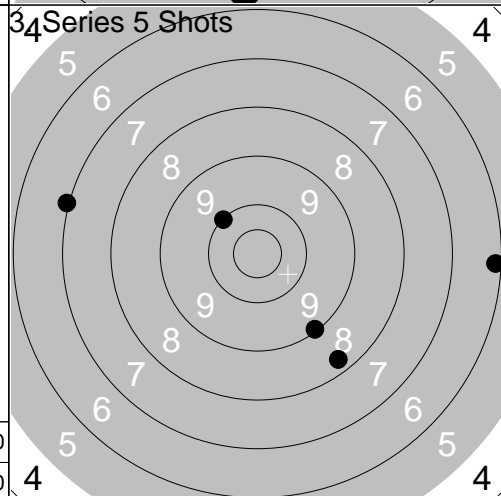

1:	9.1	↘
2:	10.0	↗
3:	8.3	↘
4:	7.0	←
5:	6.1	→
Series		40.0
Total		136.0

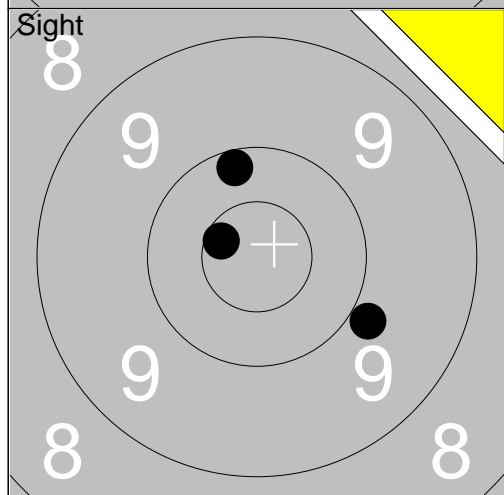

1:	*10.6	←
2:	10.2	↑
3:	9.9	↘
Series		29.0
Total		136.0

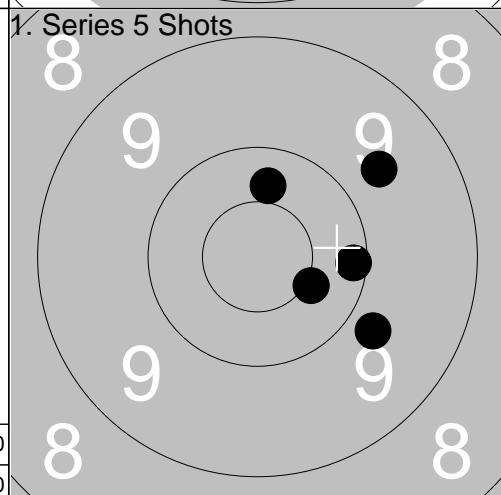

1:	*10.4	↘
2:	9.8	↘
3:	9.7	↗
4:	10.3	↑
5:	10.1	→
Series		48.0
Total		184.0

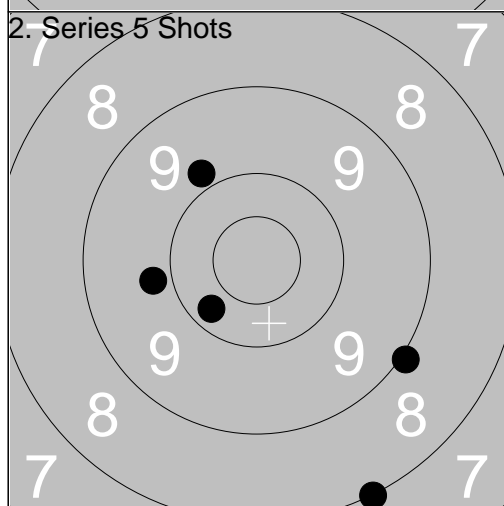

1:	10.2	↘
2:	9.9	↗
3:	9.0	↘
4:	9.8	←
5:	8.0	↘
Series		45.0
Total		229.0



1:	10.2	↑
2:	*10.5	↑
3:	9.7	→
4:	10.3	↘
5:	10.3	↓
Series		49.0
Total		0.0

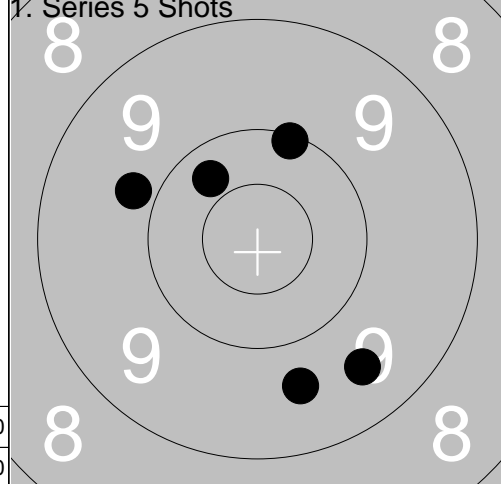

1:	9.8	↖
2:	10.1	↑
3:	9.6	↘
4:	10.3	↗
5:	9.5	↘
Series		47.0
Total		47.0

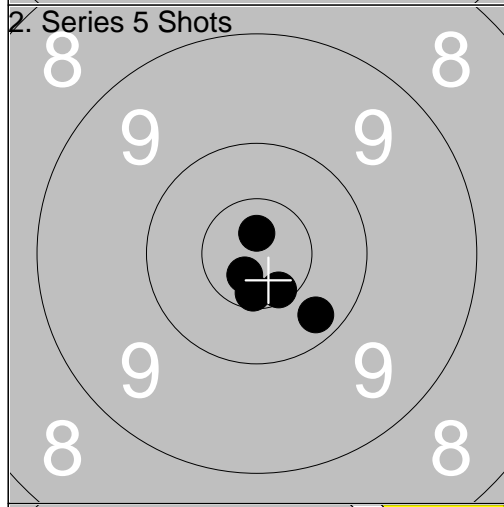

1:	10.2	↘
2:	*10.8	↑
3:	*10.7	↘
4:	*10.6	↘
5:	*10.6	↓
Series		50.0
Total		97.0

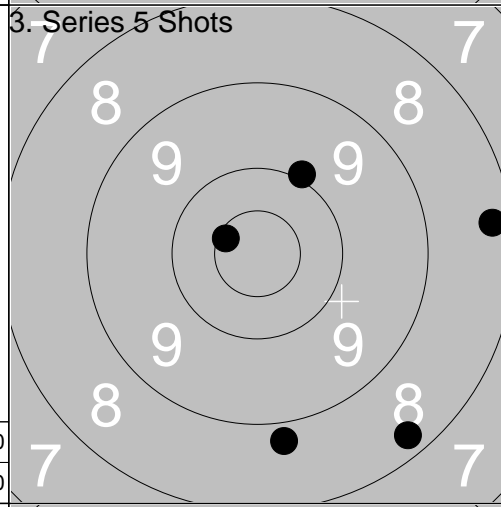

1:	*10.6	↖
2:	8.3	→
3:	8.3	↘
4:	10.0	↗
5:	8.8	↓
Series		44.0
Total		141.0

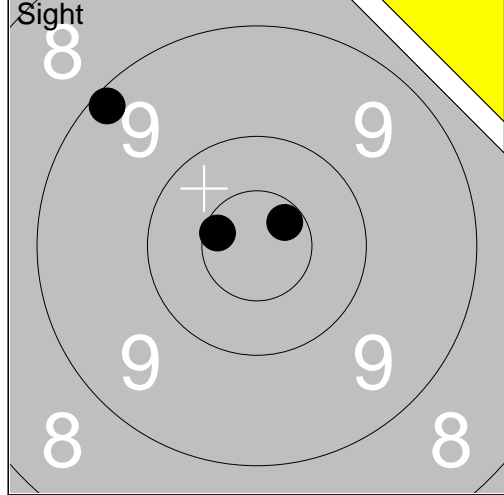

1:	*10.6	↖
2:	9.2	↗
3:	*10.6	↗
Series		29.0
Total		141.0

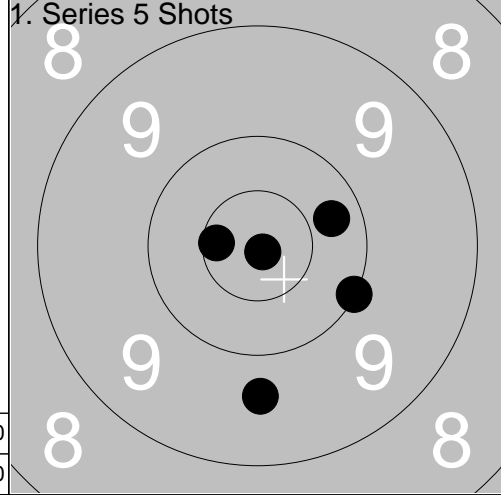

1:	10.0	↘
2:	10.3	→
3:	*10.6	↖
4:	9.7	↘
5:	*10.9	↘
Series		49.0
Total		190.0

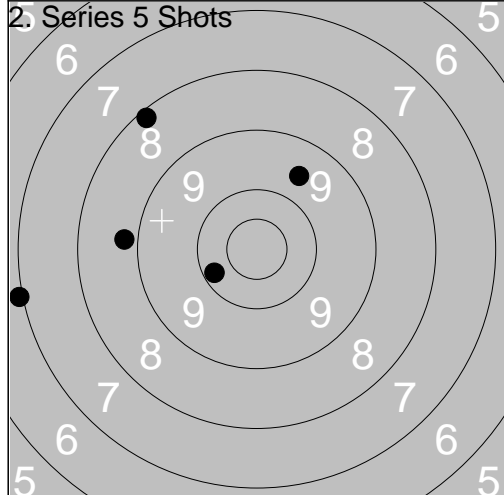

1:	8.8	↖
2:	9.6	↗
3:	10.2	↖
4:	7.0	↖
5:	8.2	↗
Series		42.0
Total		232.0

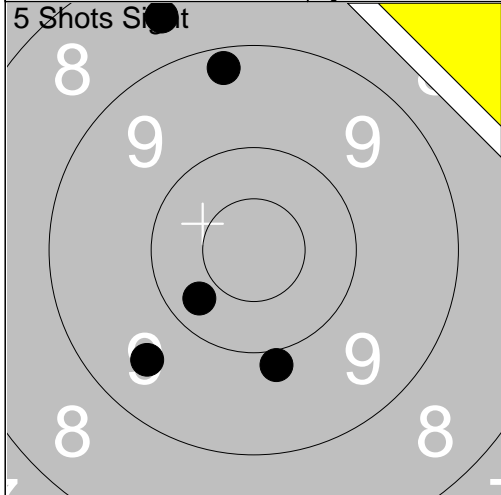

1:	9.5	↙
2:	10.3	↙
3:	9.2	↑
4:	8.6	↗
5:	9.9	↘
Series		45.0
Total		0.0

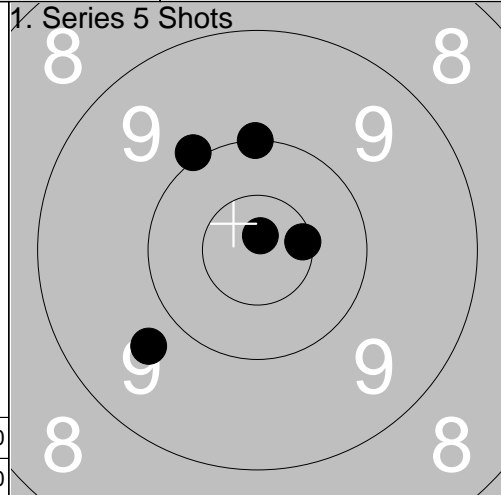

1:	10.0	↖
2:	9.7	↙
3:	*10.8	↑
4:	10.0	↑
5:	*10.6	→
Series		49.0
Total		49.0

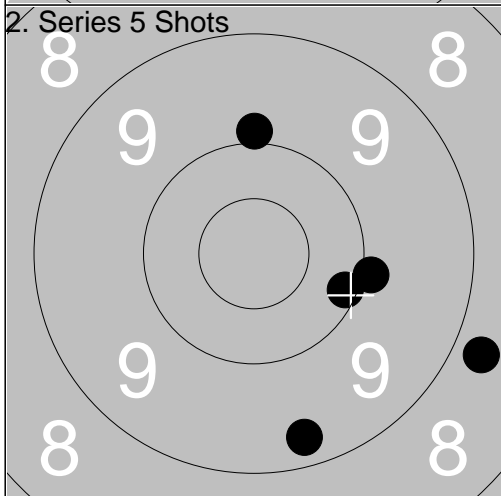

1:	9.9	↑
2:	9.9	→
3:	10.1	↘
4:	9.3	↘
5:	8.8	↘
Series		45.0
Total		94.0

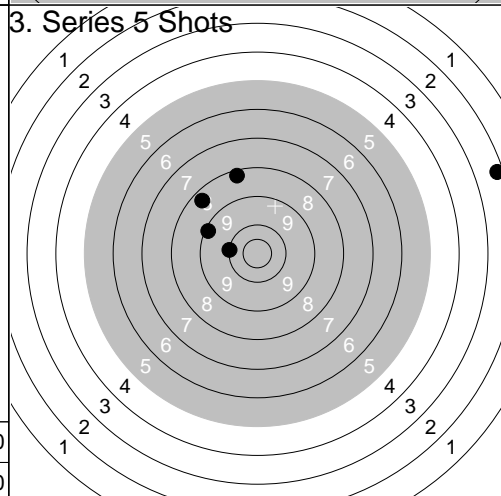

1:	10.0	←
2:	8.4	↗
3:	9.2	↖
4:	2.2	→
5:	8.2	↑
Series		37.0
Total		131.0

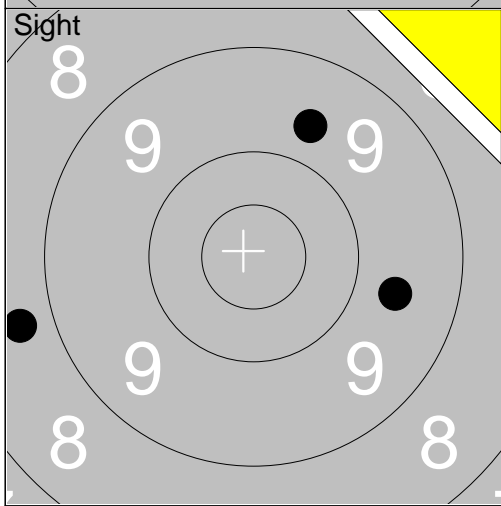

1:	9.6	→
2:	8.7	←
3:	9.7	↑
Series		26.0
Total		131.0

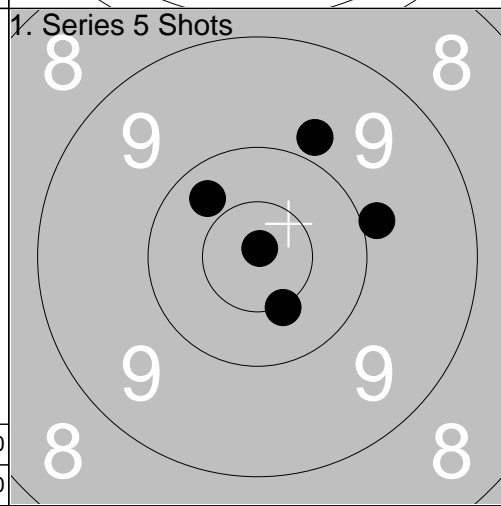

1:	*10.5	↘
2:	10.3	↗
3:	*10.9	↑
4:	9.9	→
5:	9.8	↗
Series		48.0
Total		179.0

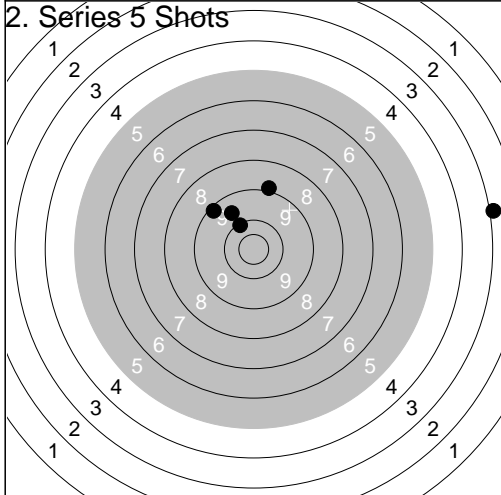

1:	9.2	↗
2:	10.1	↗
3:	9.6	↗
4:	2.9	→
5:	8.9	↑
Series		38.0
Total		217.0

Series		48.0
Total		179.0

<p>5 Shots Sight</p> <table border="1" style="width:100%; border-collapse: collapse;"> <tr><td>1:</td><td>8.3</td><td>→</td></tr> <tr><td>2:</td><td>8.3</td><td>→</td></tr> <tr><td>3:</td><td>10.0</td><td>→</td></tr> <tr><td>4:</td><td>9.4</td><td>↙</td></tr> <tr><td>5:</td><td>9.5</td><td>↗</td></tr> <tr><td colspan="2">Series</td><td>44.0</td></tr> <tr><td colspan="2">Total</td><td>0.0</td></tr> </table>	1:	8.3	→	2:	8.3	→	3:	10.0	→	4:	9.4	↙	5:	9.5	↗	Series		44.0	Total		0.0	<p>1. Series 5 Shots</p> <table border="1" style="width:100%; border-collapse: collapse;"> <tr><td>1:</td><td>*10.5</td><td>↙</td></tr> <tr><td>2:</td><td>8.6</td><td>↓</td></tr> <tr><td>3:</td><td>10.2</td><td>↑</td></tr> <tr><td>4:</td><td>*10.8</td><td>←</td></tr> <tr><td>5:</td><td>9.1</td><td>↙</td></tr> <tr><td colspan="2">Series</td><td>47.0</td></tr> <tr><td colspan="2">Total</td><td>47.0</td></tr> </table>	1:	*10.5	↙	2:	8.6	↓	3:	10.2	↑	4:	*10.8	←	5:	9.1	↙	Series		47.0	Total		47.0	
1:	8.3	→																																										
2:	8.3	→																																										
3:	10.0	→																																										
4:	9.4	↙																																										
5:	9.5	↗																																										
Series		44.0																																										
Total		0.0																																										
1:	*10.5	↙																																										
2:	8.6	↓																																										
3:	10.2	↑																																										
4:	*10.8	←																																										
5:	9.1	↙																																										
Series		47.0																																										
Total		47.0																																										

<p>2. Series 5 Shots</p> <table border="1" style="width:100%; border-collapse: collapse;"> <tr><td>1:</td><td>9.7</td><td>↑</td></tr> <tr><td>2:</td><td>10.1</td><td>←</td></tr> <tr><td>3:</td><td>10.4</td><td>←</td></tr> <tr><td>4:</td><td>*10.7</td><td>←</td></tr> <tr><td>5:</td><td>10.3</td><td>↙</td></tr> <tr><td colspan="2">Series</td><td>49.0</td></tr> <tr><td colspan="2">Total</td><td>96.0</td></tr> </table>	1:	9.7	↑	2:	10.1	←	3:	10.4	←	4:	*10.7	←	5:	10.3	↙	Series		49.0	Total		96.0	<p>3. Series 5 Shots</p> <table border="1" style="width:100%; border-collapse: collapse;"> <tr><td>1:</td><td>9.9</td><td>↓</td></tr> <tr><td>2:</td><td>8.4</td><td>↘</td></tr> <tr><td>3:</td><td>9.8</td><td>↙</td></tr> <tr><td>4:</td><td>6.4</td><td>↑</td></tr> <tr><td>5:</td><td>9.0</td><td>↑</td></tr> <tr><td colspan="2">Series</td><td>41.0</td></tr> <tr><td colspan="2">Total</td><td>137.0</td></tr> </table>	1:	9.9	↓	2:	8.4	↘	3:	9.8	↙	4:	6.4	↑	5:	9.0	↑	Series		41.0	Total		137.0	
1:	9.7	↑																																										
2:	10.1	←																																										
3:	10.4	←																																										
4:	*10.7	←																																										
5:	10.3	↙																																										
Series		49.0																																										
Total		96.0																																										
1:	9.9	↓																																										
2:	8.4	↘																																										
3:	9.8	↙																																										
4:	6.4	↑																																										
5:	9.0	↑																																										
Series		41.0																																										
Total		137.0																																										

<p>Sight</p> <table border="1" style="width:100%; border-collapse: collapse;"> <tr><td>1:</td><td>*10.5</td><td>↖</td></tr> <tr><td>2:</td><td>9.6</td><td>↙</td></tr> <tr><td>3:</td><td>9.7</td><td>←</td></tr> <tr><td colspan="2">Series</td><td>28.0</td></tr> <tr><td colspan="2">Total</td><td>137.0</td></tr> </table>	1:	*10.5	↖	2:	9.6	↙	3:	9.7	←	Series		28.0	Total		137.0	<p>1. Series 5 Shots</p> <table border="1" style="width:100%; border-collapse: collapse;"> <tr><td>1:</td><td>10.3</td><td>↘</td></tr> <tr><td>2:</td><td>10.3</td><td>→</td></tr> <tr><td>3:</td><td>10.1</td><td>↗</td></tr> <tr><td>4:</td><td>9.4</td><td>↗</td></tr> <tr><td>5:</td><td>10.0</td><td>↘</td></tr> <tr><td colspan="2">Series</td><td>49.0</td></tr> <tr><td colspan="2">Total</td><td>186.0</td></tr> </table>	1:	10.3	↘	2:	10.3	→	3:	10.1	↗	4:	9.4	↗	5:	10.0	↘	Series		49.0	Total		186.0	
1:	*10.5	↖																																				
2:	9.6	↙																																				
3:	9.7	←																																				
Series		28.0																																				
Total		137.0																																				
1:	10.3	↘																																				
2:	10.3	→																																				
3:	10.1	↗																																				
4:	9.4	↗																																				
5:	10.0	↘																																				
Series		49.0																																				
Total		186.0																																				

<p>2. Series 5 Shots</p> <table border="1" style="width:100%; border-collapse: collapse;"> <tr><td>1:</td><td>9.4</td><td>↑</td></tr> <tr><td>2:</td><td>8.3</td><td>↑</td></tr> <tr><td>3:</td><td>8.6</td><td>↗</td></tr> <tr><td>4:</td><td>8.4</td><td>→</td></tr> <tr><td>5:</td><td>8.9</td><td>↙</td></tr> <tr><td colspan="2">Series</td><td>41.0</td></tr> <tr><td colspan="2">Total</td><td>227.0</td></tr> </table>	1:	9.4	↑	2:	8.3	↑	3:	8.6	↗	4:	8.4	→	5:	8.9	↙	Series		41.0	Total		227.0		
1:	9.4	↑																					
2:	8.3	↑																					
3:	8.6	↗																					
4:	8.4	→																					
5:	8.9	↙																					
Series		41.0																					
Total		227.0																					

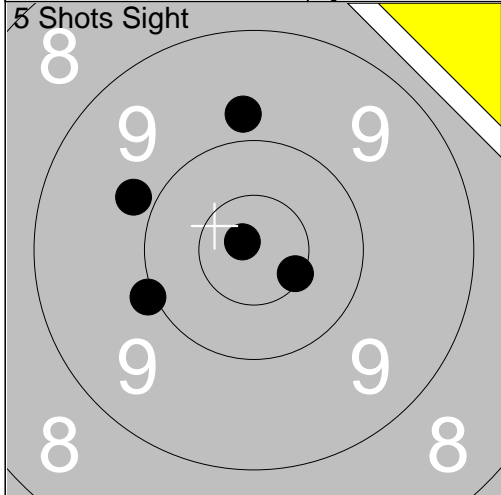

1: *10.8 ↖
2: 9.8 ↖
3: 9.8 ↑
4: 10.0 ←
5: *10.5 ↘
Series 48.0
Total 0.0

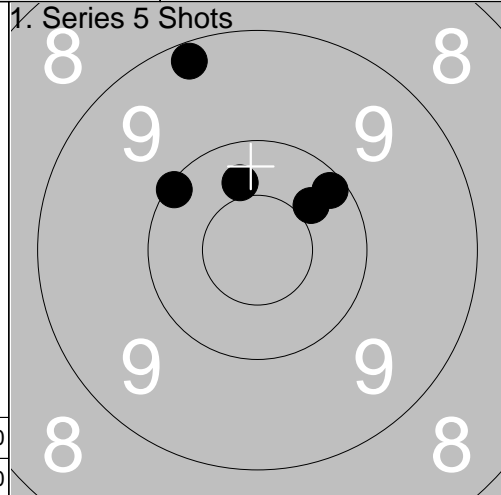

1: 10.1 ↖
2: 10.2 ↗
3: 10.4 ↗
4: 10.4 ↑
5: 9.2 ↑
Series 49.0
Total 49.0

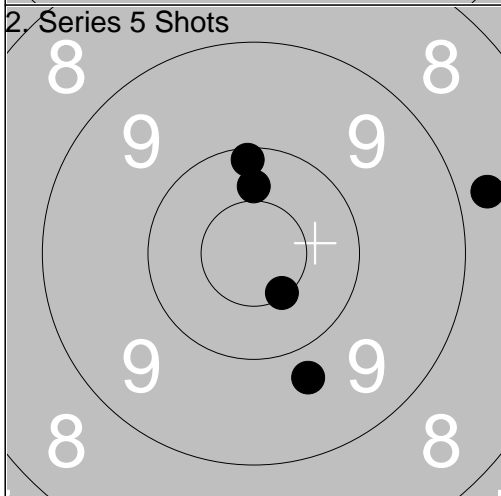

1: 8.7 →
2: 10.1 ↑
3: 10.4 ↑
4: 9.8 ↓
5: *10.5 ↓
Series 47.0
Total 96.0

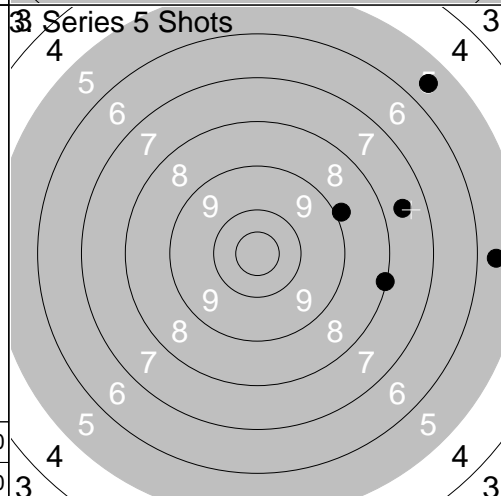

1: 7.6 →
2: 8.9 ↗
3: 5.6 ↗
4: 5.6 →
5: 8.1 →
Series 33.0
Total 129.0

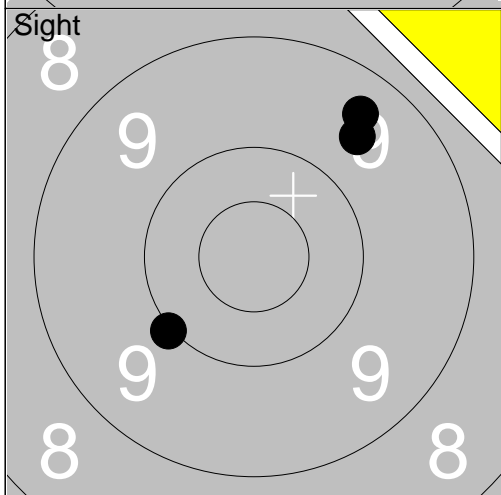

1: 9.6 ↗
2: 10.0 ↖
3: 9.4 ↗
Series 28.0
Total 129.0

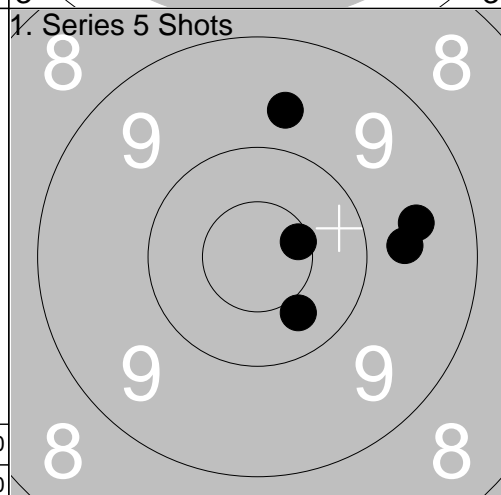

1: 9.6 →
2: 9.7 ↑
3: *10.6 →
4: 9.7 →
5: 10.4 ↓
Series 47.0
Total 176.0

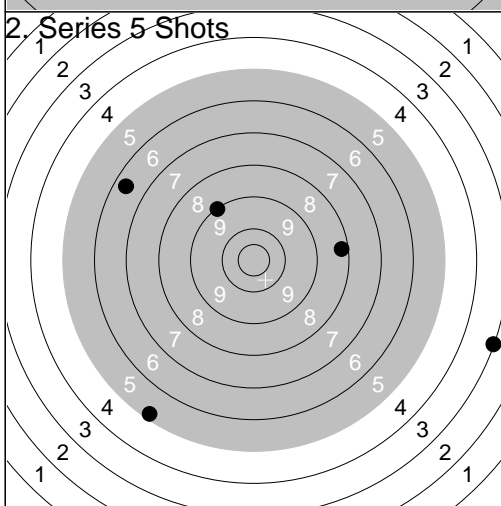

1: 9.0 ↗
2: 6.4 ↗
3: 8.3 →
4: 5.2 ↓
5: 3.1 →
Series 31.0
Total 207.0

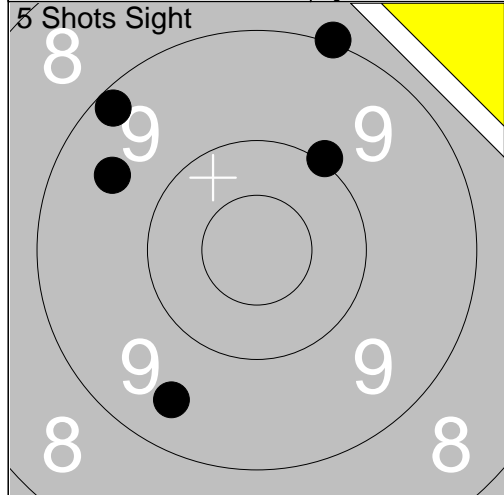

1:	9.6	↖
2:	9.2	↗
3:	9.5	↘
4:	9.0	↗
5:	10.0	↗
Series		46.0
Total		0.0

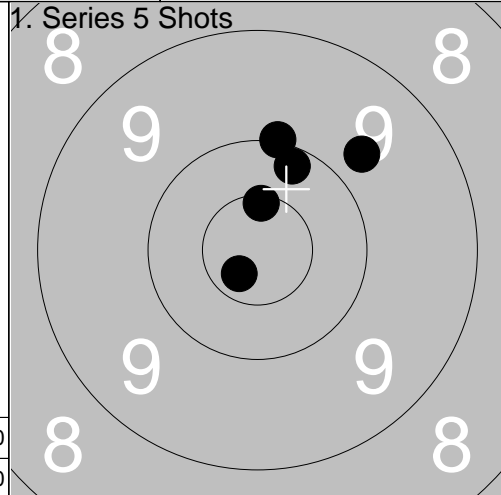

1:	10.0	↑
2:	10.2	↗
3:	*10.6	↑
4:	*10.7	↘
5:	9.7	↗
Series		49.0
Total		49.0

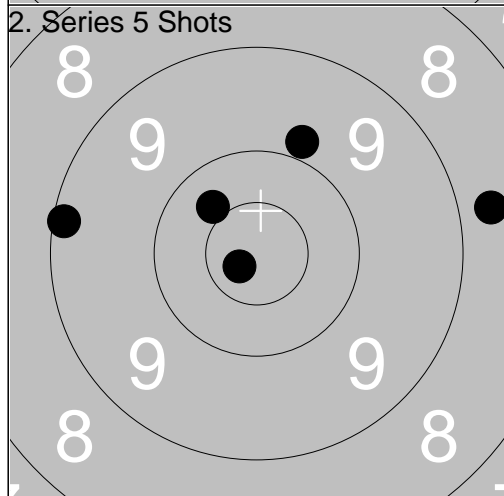

1:	*10.8	↖
2:	9.1	↖
3:	9.9	↗
4:	8.7	→
5:	10.4	↗
Series		46.0
Total		95.0

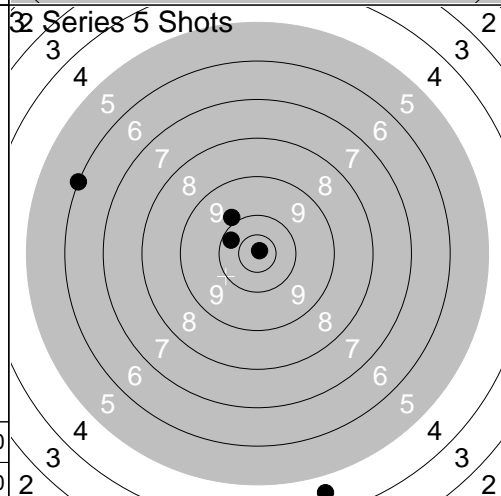

1:	10.2	↖
2:	9.9	↗
3:	4.6	↘
4:	*10.9	↗
5:	6.0	↖
Series		39.0
Total		134.0

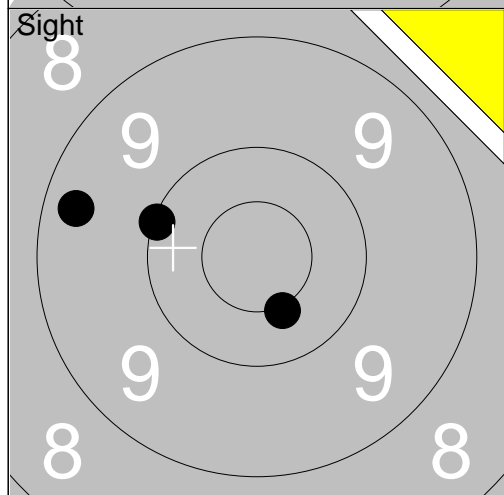

1:	*10.5	↘
2:	10.1	↖
3:	9.3	↖
Series		29.0
Total		134.0

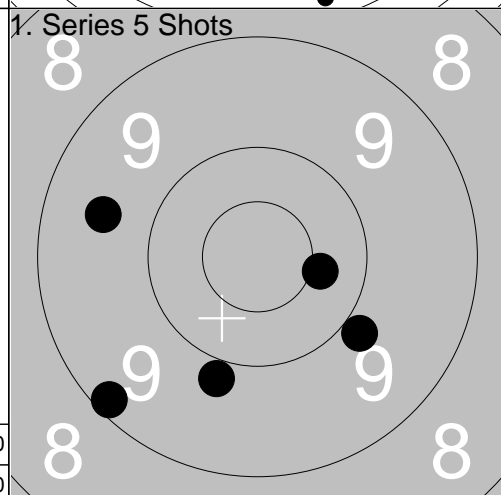

1:	9.2	↘
2:	9.6	↖
3:	9.9	↘
4:	9.9	↘
5:	10.4	→
Series		46.0
Total		180.0

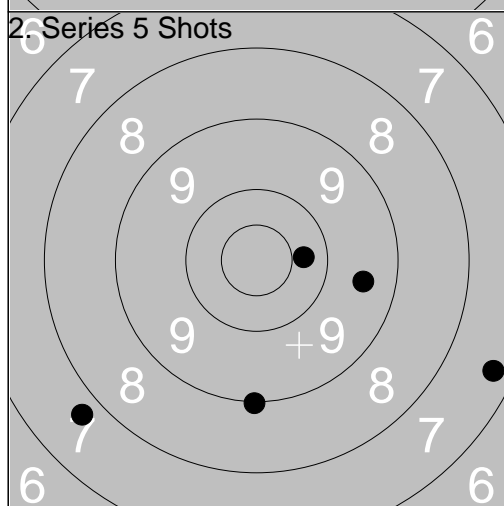

1:	7.3	→
2:	9.0	↓
3:	10.3	→
4:	7.7	↖
5:	9.5	→
Series		42.0
Total		222.0

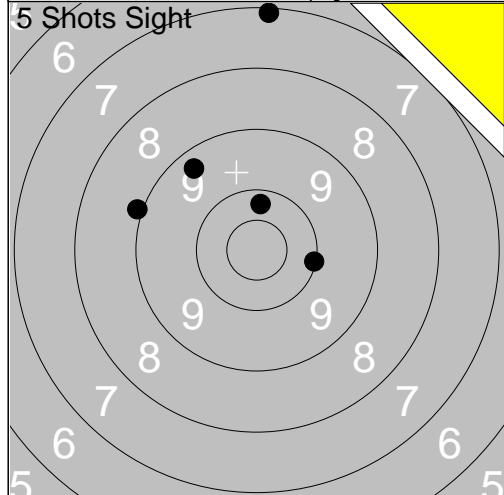

1:	7.1	↑
2:	10.1	→
3:	10.2	↑
4:	9.3	↗
5:	9.0	↑

Series	45.0
Total	0.0

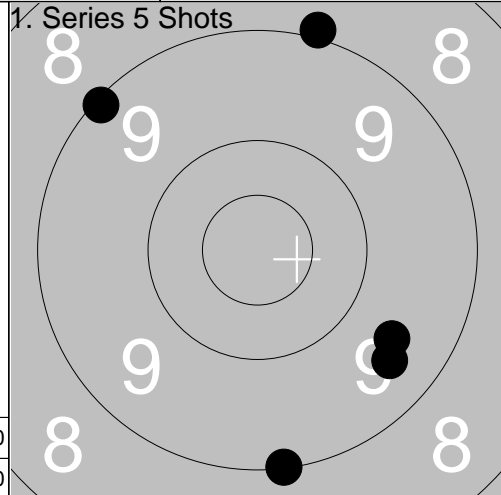

1:	9.0	↑
2:	9.0	↓
3:	9.5	↘
4:	9.6	↘
5:	9.1	↗

Series	45.0
Total	45.0

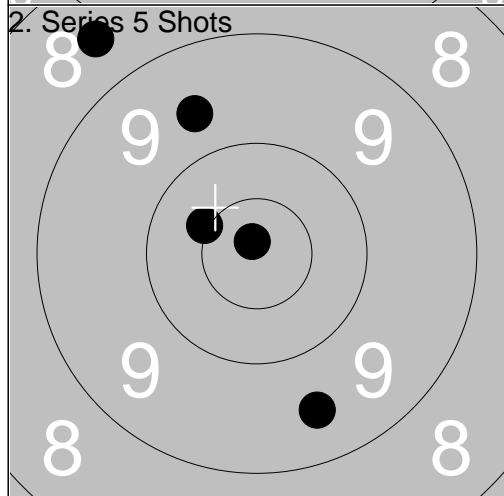

1:	*10.5	↖
2:	9.5	↓
3:	8.6	↗
4:	*10.8	↗
5:	9.6	↗

Series	46.0
Total	91.0

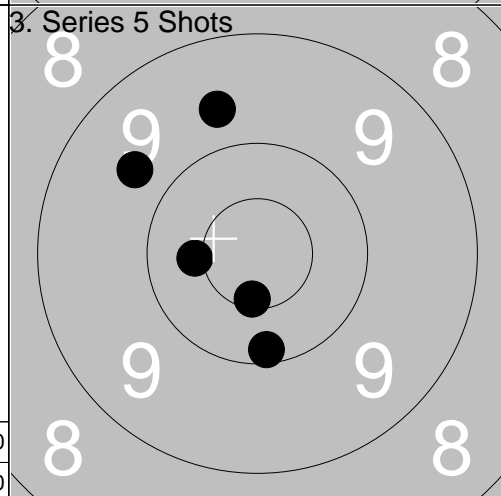

1:	*10.6	↓
2:	10.1	↓
3:	*10.4	←
4:	9.7	↑
5:	9.7	↗

Series	48.0
Total	139.0

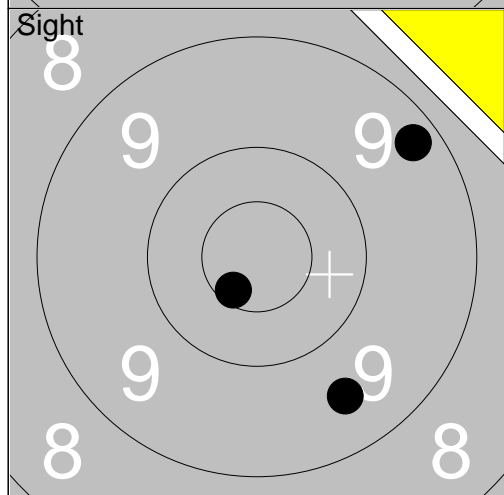

1:	9.3	↗
2:	*10.6	↘
3:	9.5	↓

Series	28.0
Total	139.0

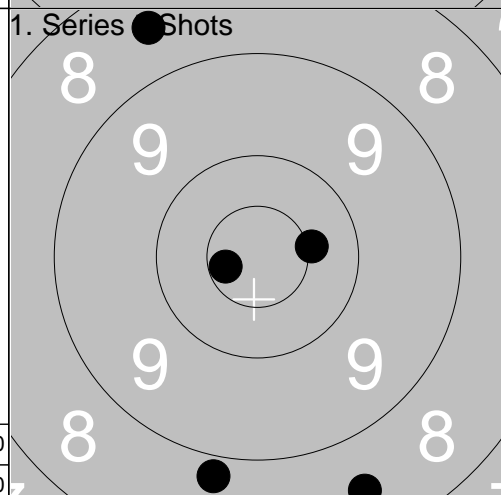

1:	*10.6	←
2:	8.5	↗
3:	8.5	↓
4:	8.8	↓
5:	*10.4	→

Series	44.0
Total	183.0

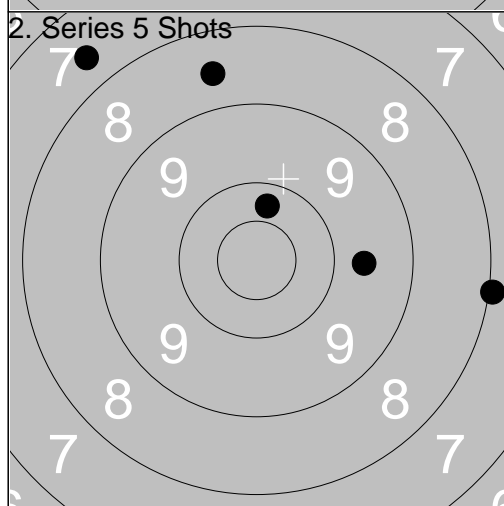

1:	8.6	↑
2:	8.0	→
3:	9.7	→
4:	7.6	↗
5:	10.3	↑

Series	42.0
Total	225.0

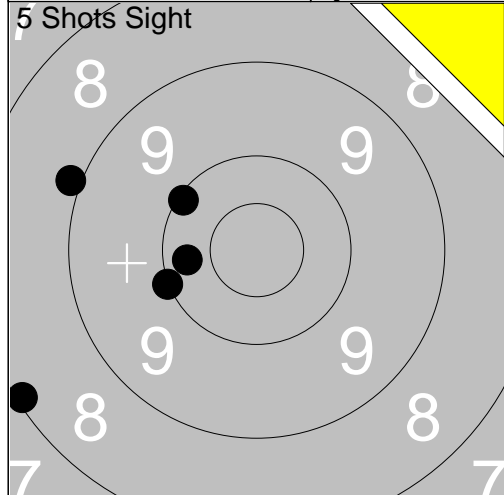

1:	8.9	←
2:	10.1	↖
3:	10.3	←
4:	8.1	↙
5:	10.0	←
Series		46.0
Total		0.0

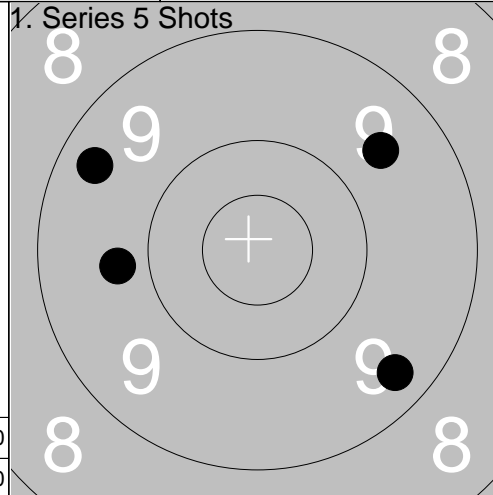

1:	9.8	←
2:	9.6	↗
3:	9.4	↖
4:	9.4	↘
5:	0.0	
Series		36.0
Total		36.0

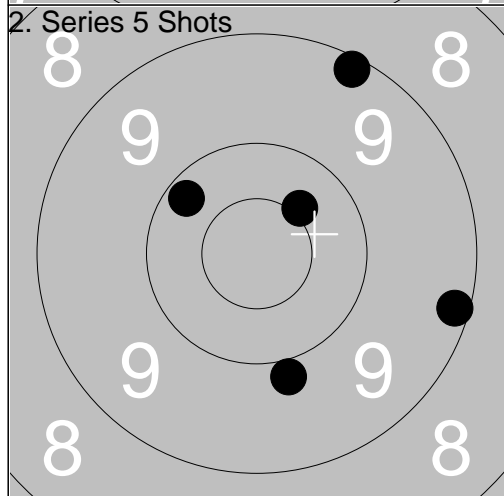

1:	*10.4	↗
2:	9.1	↗
3:	9.9	↘
4:	10.2	↗
5:	9.2	→
Series		47.0
Total		83.0

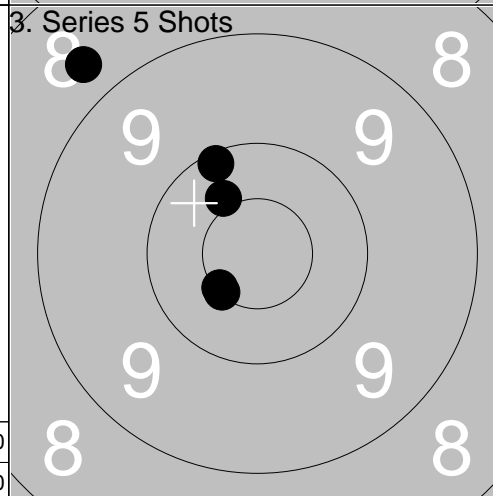

1:	8.7	↖
2:	*10.5	↙
3:	*10.5	↙
4:	10.1	↗
5:	10.4	↗
Series		48.0
Total		131.0

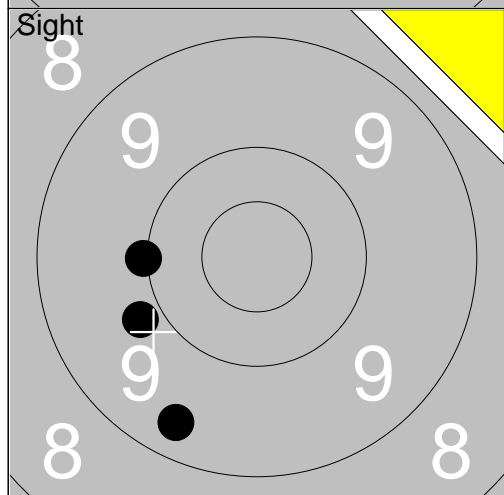

1:	9.8	←
2:	10.0	←
3:	9.4	↘
Series		28.0
Total		131.0

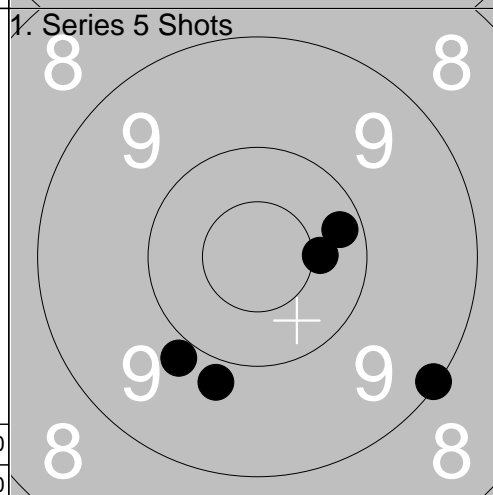

1:	9.9	↘
2:	10.2	→
3:	9.1	↘
4:	*10.4	→
5:	9.8	↘
Series		47.0
Total		178.0

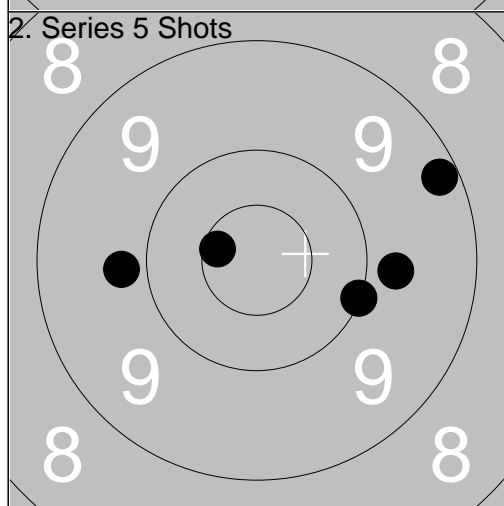

1:	9.2	→
2:	9.8	→
3:	*10.6	←
4:	9.8	←
5:	10.0	→
Series		47.0
Total		225.0

<p>5 Shots Sight</p>	<p>1. Series 5 Shots</p>	
----------------------	--------------------------	--

<p>2. Series 5 Shots</p>	<p>3. Series 5 Shots</p>	
--------------------------	--------------------------	--

<p>Sight</p>	<p>1. Series 5 Shots</p>	
--------------	--------------------------	--

<p>2. Series 5 Shots</p>		
--------------------------	--	--

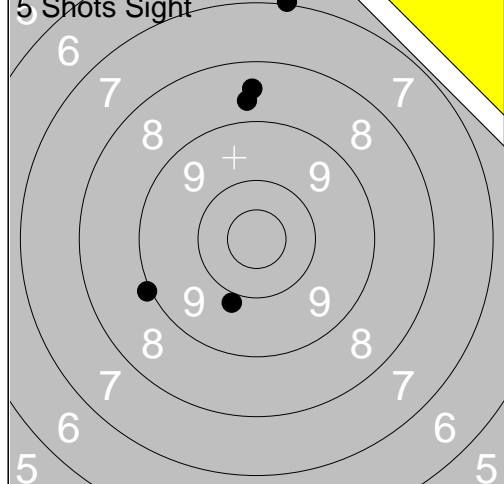

1:	7.0	↑
2:	8.7	↑
3:	8.5	↑
4:	9.0	↙
5:	9.9	↓
Series		41.0
Total		0.0

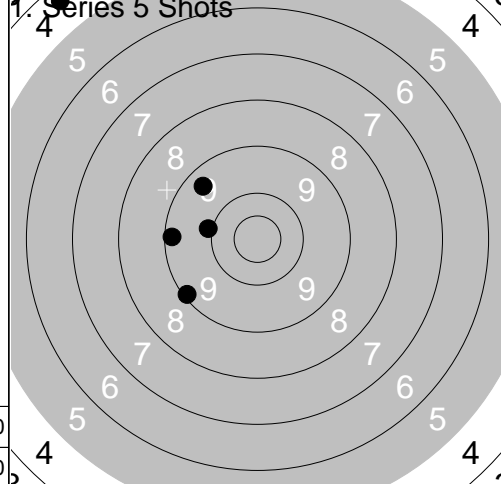

1:	9.2	←
2:	9.1	↙
3:	9.9	←
4:	9.4	↗
5:	4.4	↗
Series		40.0
Total		40.0

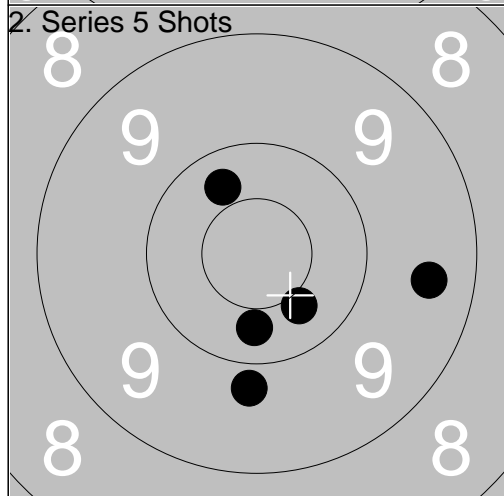

1:	9.4	→
2:	9.8	↓
3:	10.3	↓
4:	10.4	↘
5:	10.3	↗
Series		48.0
Total		88.0

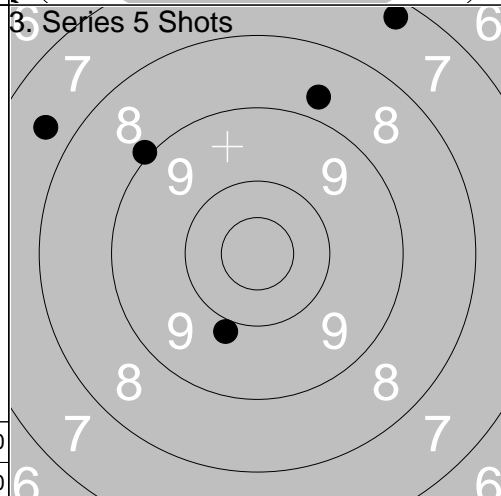

1:	8.9	↖
2:	7.6	↖
3:	9.9	↓
4:	7.3	↗
5:	8.7	↗
Series		39.0
Total		127.0

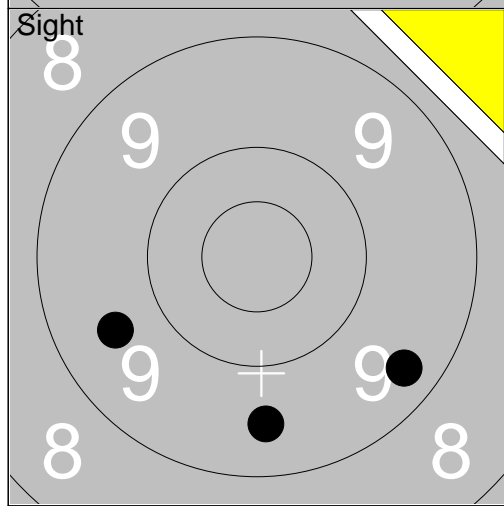

1:	9.6	↙
2:	9.5	↓
3:	9.4	↘
Series		27.0
Total		127.0

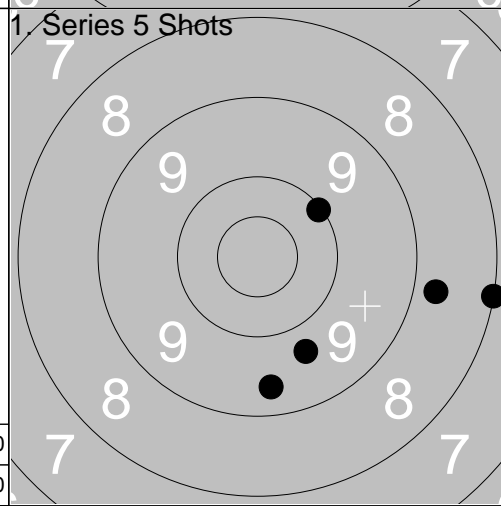

1:	9.4	↓
2:	8.0	→
3:	9.7	↓
4:	8.8	→
5:	10.1	↗
Series		44.0
Total		171.0

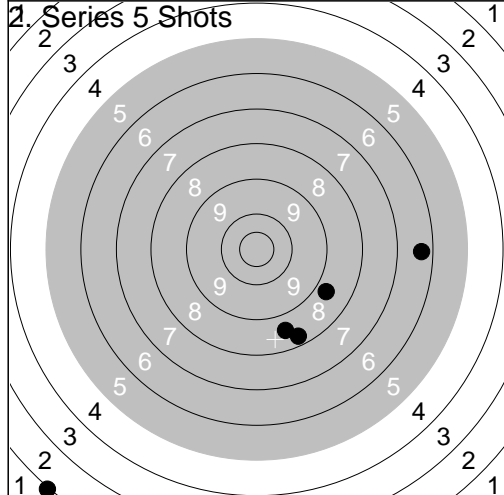

1:	8.7	↘
2:	6.3	→
3:	8.6	↓
4:	8.3	↓
5:	2.0	↙
Series		32.0
Total		203.0

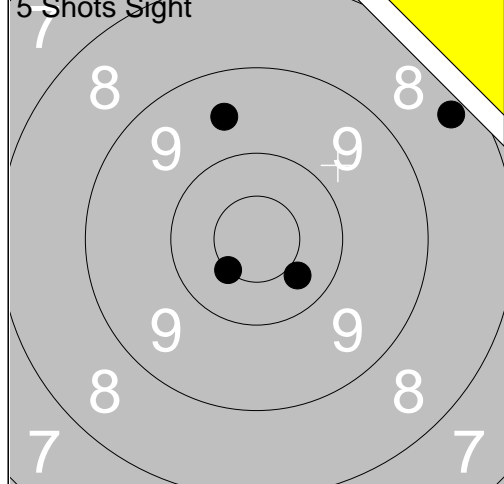

1:	7.5	↗
2:	8.3	↗
3:	*10.5	↙
4:	10.4	↘
5:	9.6	↗
Series		44.0
Total		0.0

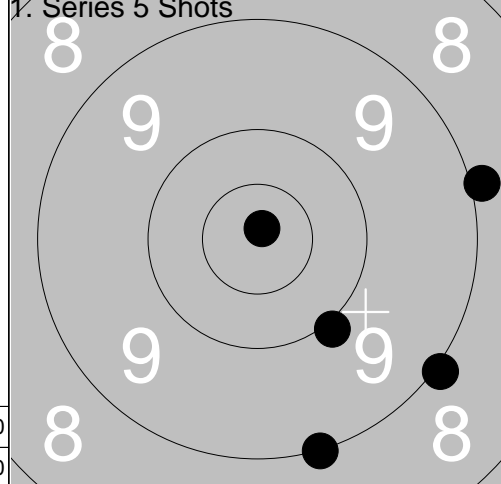

1:	8.9	→
2:	9.0	↘
3:	*10.9	↗
4:	9.0	↘
5:	10.0	↘
Series		46.0
Total		46.0

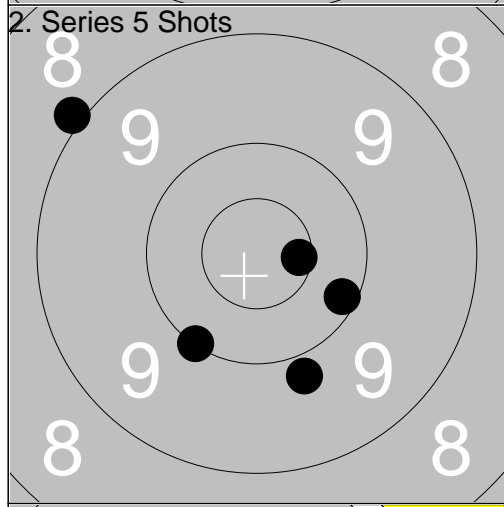

1:	8.9	↖
2:	*10.6	→
3:	10.0	↘
4:	10.1	↘
5:	9.8	↘
Series		47.0
Total		93.0

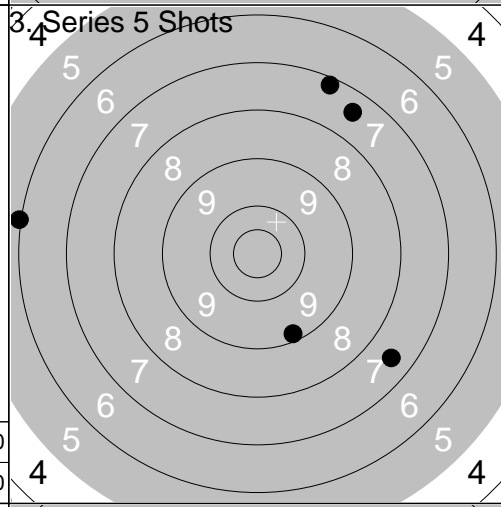

1:	7.2	↗
2:	6.0	←
3:	9.2	↘
4:	7.5	↘
5:	7.5	↗
Series		36.0
Total		129.0

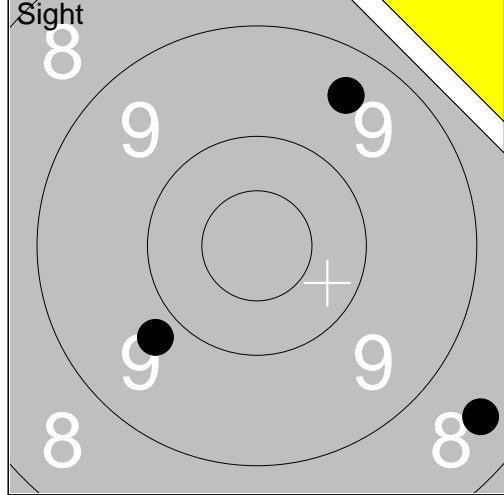

1:	8.5	↘
2:	9.8	↙
3:	9.4	↗
Series		26.0
Total		129.0

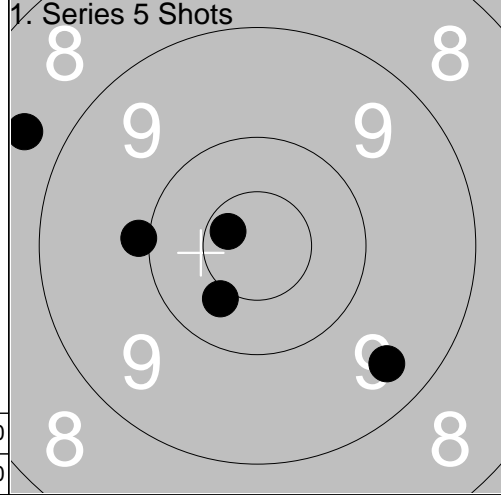

1:	8.7	↖
2:	10.4	↘
3:	*10.7	↗
4:	9.4	↘
5:	9.9	←
Series		46.0
Total		175.0

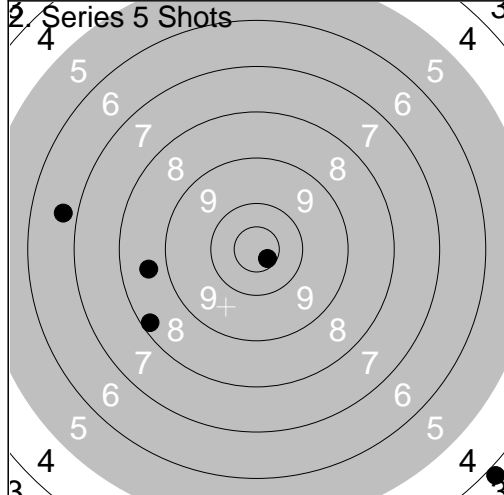

1:	*10.7	↘
2:	8.6	←
3:	6.7	←
4:	8.2	↘
5:	3.9	↘
Series		35.0
Total		210.0

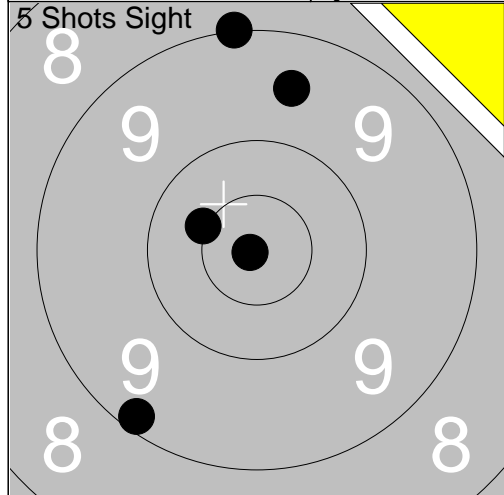

1:	9.0	↑
2:	9.5	↑
3:	*10.5	↖
4:	*10.9	←
5:	9.2	↙
Series		47.0
Total		0.0

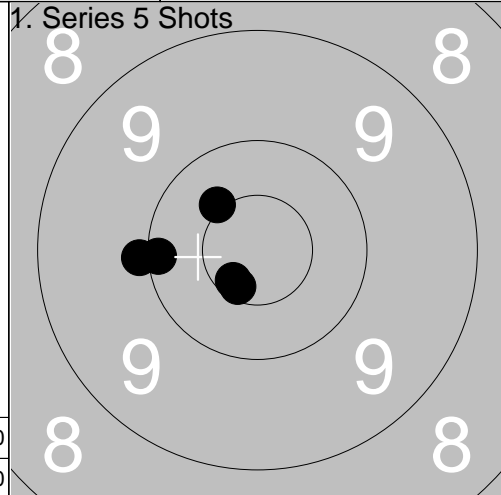

1:	*10.4	↖
2:	*10.6	↙
3:	10.0	←
4:	10.1	←
5:	*10.6	↙
Series		50.0
Total		50.0

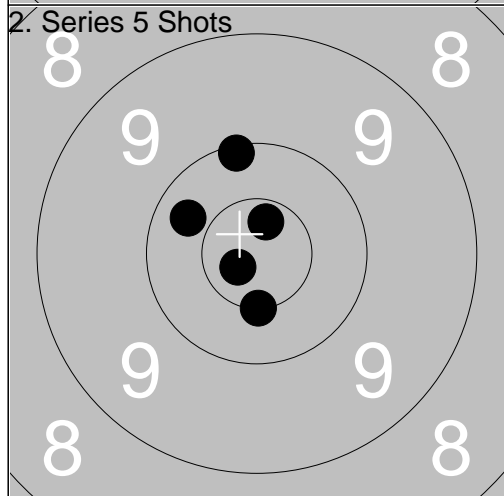

1:	10.3	↖
2:	*10.5	↙
3:	10.1	↑
4:	*10.7	↑
5:	*10.8	↙
Series		50.0
Total		100.0

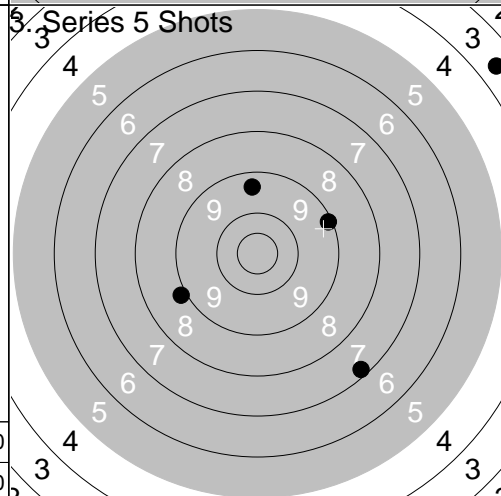

1:	8.9	←
2:	9.4	↑
3:	9.1	↗
4:	7.2	↘
5:	3.6	↗
Series		36.0
Total		136.0

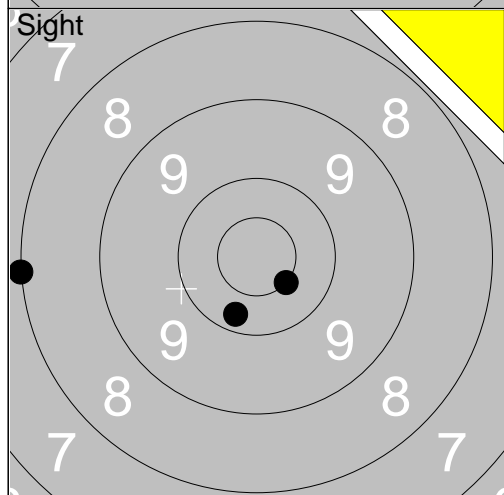

1:	*10.5	↘
2:	10.2	↘
3:	8.0	←
Series		28.0
Total		136.0

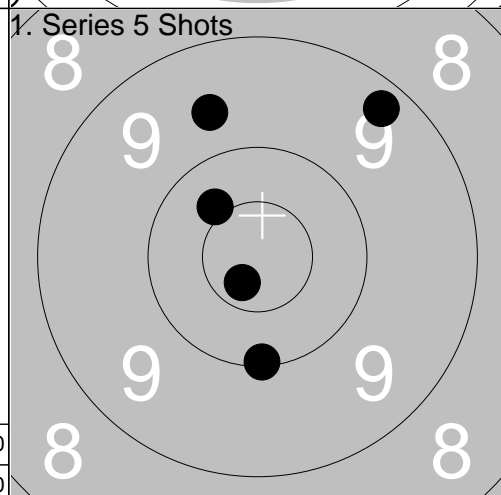

1:	9.6	↑
2:	*10.7	↙
3:	10.1	↘
4:	9.3	↗
5:	10.4	↖
Series		48.0
Total		184.0

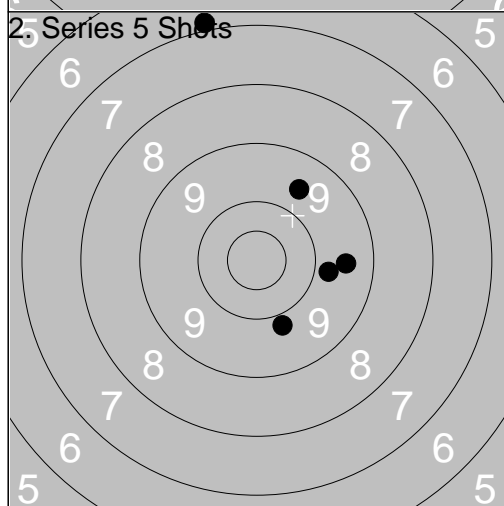

1:	9.8	→
2:	9.5	→
3:	9.8	↘
4:	9.6	↗
5:	6.9	↑
Series		42.0
Total		226.0

<p>5 Shots Sight</p>	<p>1. Series 5 Shots</p>	<p>1: 8.2 ↓ 2: 9.5 ↓ 3: 9.9 ← 4: 10.0 ↑ 5: 10.3 →</p> <p>Series 46.0 Total 0.0</p>	<p>1: *10.5 ↖ 2: *10.8 ↓ 3: 9.9 ← 4: *10.4 ↓ 5: 9.7 ↓</p> <p>Series 48.0 Total 48.0</p>
----------------------	--------------------------	--	---

<p>2. Series 5 Shots</p>	<p>3. Series 5 Shots</p>	<p>1: 10.2 ← 2: 10.3 → 3: 10.2 ↗ 4: *10.5 ↓ 5: 10.1 ←</p> <p>Series 50.0 Total 98.0</p>	<p>1: 10.1 ← 2: 10.4 ← 3: 10.1 → 4: 5.9 → 5: 6.7 ↗</p> <p>Series 41.0 Total 139.0</p>
--------------------------	--------------------------	---	---

<p>Sight</p>	<p>1. Series 5 Shots</p>	<p>1: 9.3 → 2: 10.2 ↓ 3: 10.0 →</p> <p>Series 29.0 Total 139.0</p>	<p>1: 9.1 → 2: 9.8 ↓ 3: 9.8 → 4: 9.9 ↗ 5: 9.8 ↗</p> <p>Series 45.0 Total 184.0</p>
--------------	--------------------------	--	--

<p>2. Series 5 Shots</p>	<p>Series 41.0 Total 225.0</p>	<p>1: 7.3 ← 2: 8.4 ← 3: 9.3 ↑ 4: *10.4 ↓ 5: 7.7 ↘</p>	
--------------------------	------------------------------------	---	--

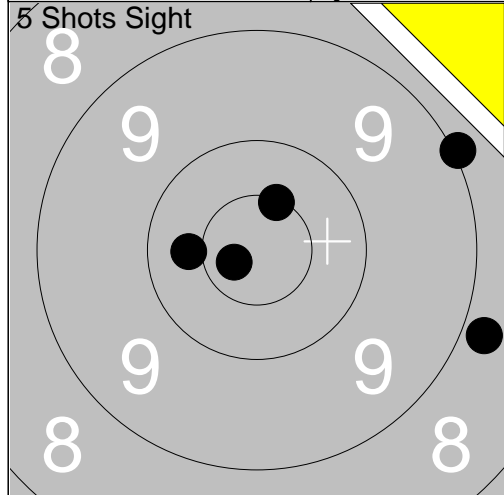

1:	*10.7	↙
2:	10.4	←
3:	*10.5	↗
4:	9.0	↘
5:	8.8	↘
Series		47.0
Total		0.0

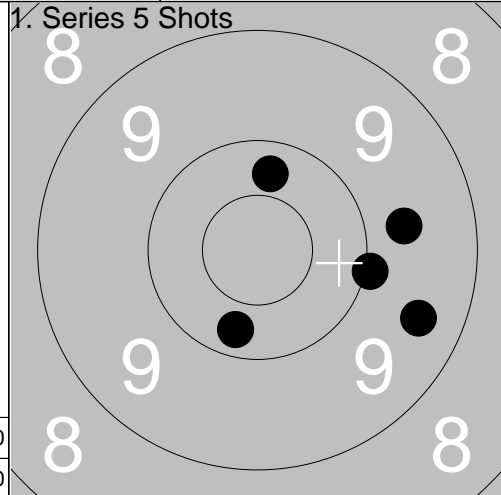

1:	10.3	↑
2:	9.4	↘
3:	10.3	↓
4:	9.7	→
5:	10.0	→
Series		48.0
Total		48.0

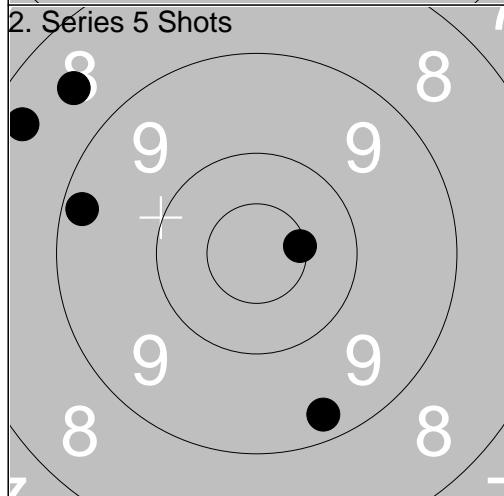

1:	*10.5	→
2:	9.2	←
3:	9.3	↙
4:	8.6	↗
5:	8.4	↗
Series		44.0
Total		92.0

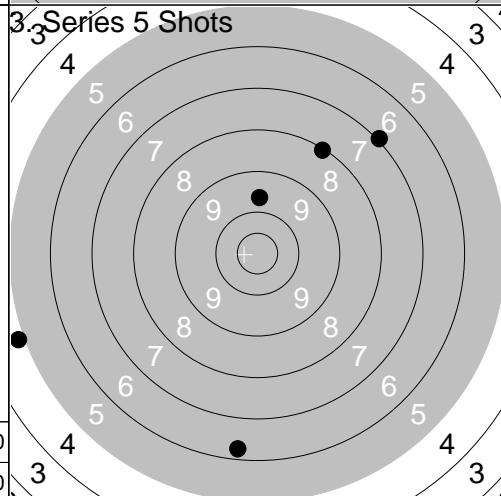

1:	9.7	↑
2:	7.0	↗
3:	8.1	↗
4:	6.3	↓
5:	4.9	←
Series		34.0
Total		126.0

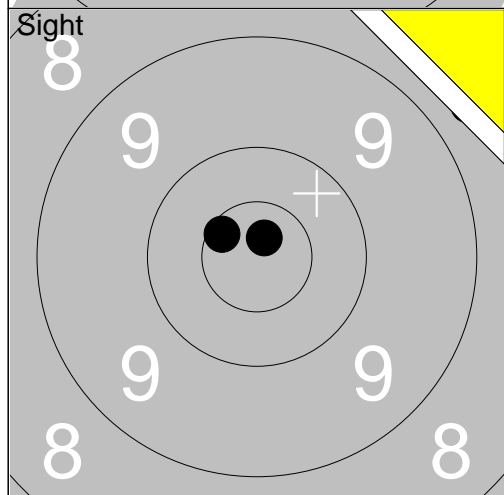

1:	*10.8	↗
2:	*10.6	↙
3:	8.7	↘
Series		28.0
Total		126.0

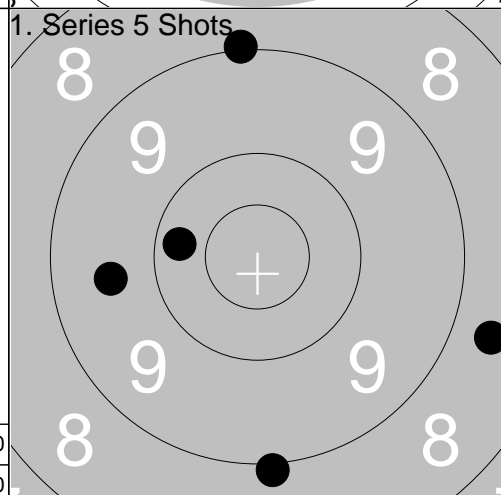

1:	9.0	↑
2:	8.6	→
3:	9.0	↓
4:	9.6	←
5:	10.2	←
Series		45.0
Total		171.0

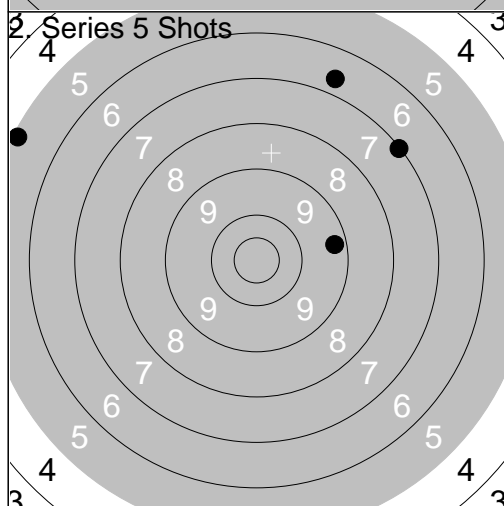

1:	6.7	↗
2:	7.1	↗
3:	9.3	→
4:	5.1	←
5:	0.0	
Series		27.0
Total		198.0

<p>5 Shots Sight</p>	<p>1: 7.3 ↙ 2: 9.6 ← 3: 10.3 ↗ 4: 9.6 → 5: 10.1 ←</p>	<p>1. Series 5 Shots</p>	<p>1: 10.1 ↗ 2: *10.6 ↗ 3: 10.0 ↓ 4: 9.6 → 5: 10.3 ↓</p>
Series 45.0		Series 49.0	
Total 0.0		Total 49.0	

<p>2. Series 5 Shots</p>	<p>1: 9.8 ← 2: 10.3 → 3: *10.7 ← 4: 9.3 ↗ 5: 10.0 ↘</p>	<p>3. Series 5 Shots</p>	<p>1: 7.7 ← 2: 9.9 ↘ 3: 8.9 → 4: 1.4 → 5: 8.9 ↓</p>
Series 48.0		Series 33.0	
Total 97.0		Total 130.0	

<p>Sight</p>	<p>1: 9.4 → 2: 10.2 ↗ 3: 10.3 ↘</p>	<p>1. Series 5 Shots</p>	<p>1: *10.6 → 2: *10.4 ← 3: 9.6 ↗ 4: 9.0 ↗ 5: 9.3 ↗</p>
Series 29.0		Series 47.0	
Total 130.0		Total 177.0	

<p>24 Series 5 Shots</p>	<p>1: *10.7 ↗ 2: *10.6 ← 3: 10.3 ↘ 4: 6.1 → 5: 8.8 ←</p>		
Series 44.0			
Total 221.0			

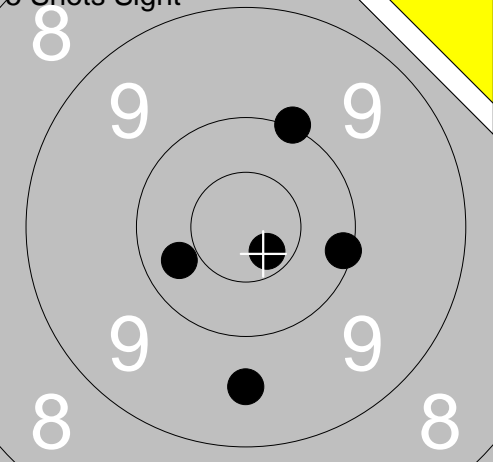
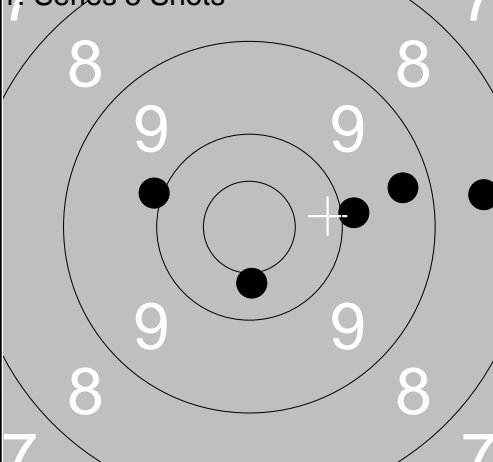
<p>5 Shots Sight</p> 	<p>1: 10.3 ↙ 2: *10.7 ↓ 3: 9.6 ↓ 4: 10.0 ↑ 5: 10.1 →</p>	<p>1. Series 5 Shots</p> 		<p>1: 9.9 ↖ 2: 9.9 → 3: 10.4 ↓ 4: 8.5 → 5: 9.3 →</p>
Series 49.0		Series 45.0		Series 45.0
Total 0.0		Total 45.0		Total 45.0

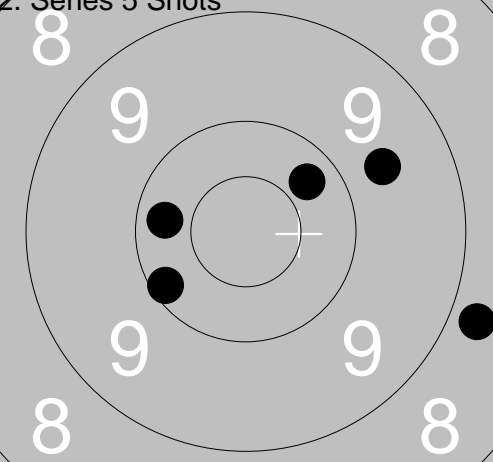
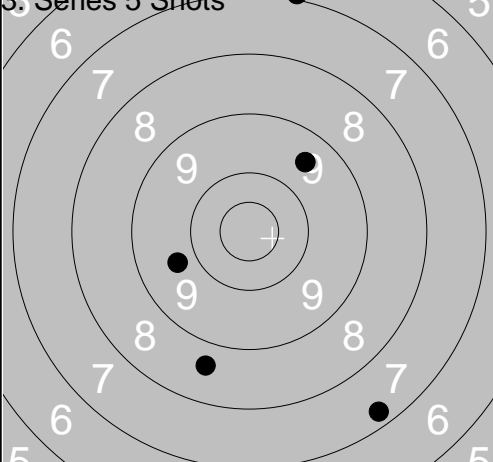
<p>2. Series 5 Shots</p> 	<p>1: 10.3 ↗ 2: 8.8 → 3: 9.7 → 4: 10.3 ← 5: 10.1 ↙</p>	<p>3. Series 5 Shots</p> 		<p>1: 6.9 ↑ 2: 9.7 ↖ 3: 9.5 ↗ 4: 8.6 ↓ 5: 7.3 ↓</p>
Series 47.0		Series 39.0		Series 39.0
Total 92.0		Total 131.0		Total 131.0

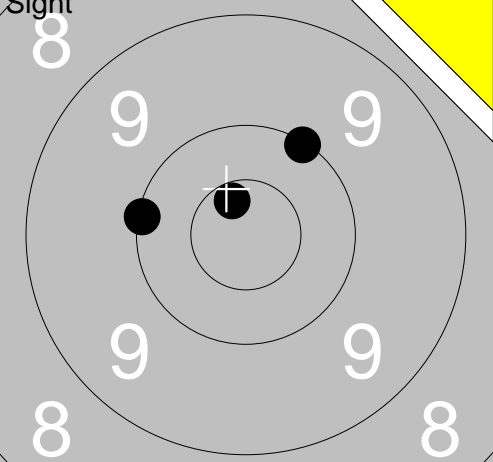
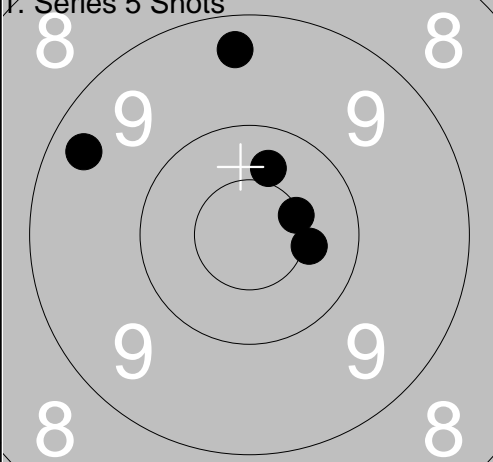
<p>Sight</p> 	<p>1: *10.6 ↑ 2: 10.1 ↑ 3: 10.1 ←</p>	<p>1. Series 5 Shots</p> 		<p>1: 10.4 ↑ 2: *10.5 → 3: *10.4 → 4: 9.3 ↑ 5: 9.3 ↖</p>
Series 30.0		Series 48.0		Series 48.0
Total 131.0		Total 179.0		Total 179.0

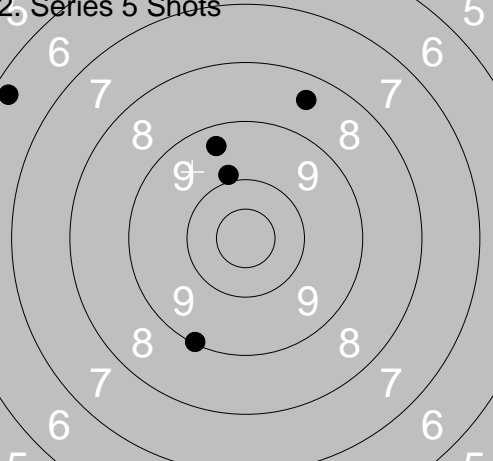
<p>2. Series 5 Shots</p> 	<p>1: 6.3 ↖ 2: 9.9 ↑ 3: 9.4 ↑ 4: 9.1 ↘ 5: 8.5 ↗</p>			
Series 41.0				
Total 220.0				

<p>5 Shots Sight</p>	<p>1. Series 5 Shots</p>	<table border="1" style="width:100%; border-collapse: collapse;"> <tr><td>1: 10.3 ↙</td></tr> <tr><td>2: 10.4 ↙</td></tr> <tr><td>3: *10.7 ↓</td></tr> <tr><td>4: 9.8 ↙</td></tr> <tr><td>Series 39.0</td></tr> <tr><td>Total 0.0</td></tr> </table>	1: 10.3 ↙	2: 10.4 ↙	3: *10.7 ↓	4: 9.8 ↙	Series 39.0	Total 0.0	<table border="1" style="width:100%; border-collapse: collapse;"> <tr><td>1: 10.2 ↗</td></tr> <tr><td>2: 10.1 ↘</td></tr> <tr><td>3: 10.0 ↗</td></tr> <tr><td>4: 10.3 ↘</td></tr> <tr><td>5: 9.4 ↘</td></tr> <tr><td>Series 49.0</td></tr> <tr><td>Total 49.0</td></tr> </table>	1: 10.2 ↗	2: 10.1 ↘	3: 10.0 ↗	4: 10.3 ↘	5: 9.4 ↘	Series 49.0	Total 49.0
1: 10.3 ↙																
2: 10.4 ↙																
3: *10.7 ↓																
4: 9.8 ↙																
Series 39.0																
Total 0.0																
1: 10.2 ↗																
2: 10.1 ↘																
3: 10.0 ↗																
4: 10.3 ↘																
5: 9.4 ↘																
Series 49.0																
Total 49.0																

<p>2. Series 5 Shots</p>	<p>3. Series 5 Shots</p>	<table border="1" style="width:100%; border-collapse: collapse;"> <tr><td>1: 9.1 ↗</td></tr> <tr><td>2: 10.1 ←</td></tr> <tr><td>3: 9.6 ↗</td></tr> <tr><td>4: 9.5 ↘</td></tr> <tr><td>5: 9.2 ↓</td></tr> <tr><td>Series 46.0</td></tr> <tr><td>Total 95.0</td></tr> </table>	1: 9.1 ↗	2: 10.1 ←	3: 9.6 ↗	4: 9.5 ↘	5: 9.2 ↓	Series 46.0	Total 95.0	<table border="1" style="width:100%; border-collapse: collapse;"> <tr><td>1: 9.4 ↘</td></tr> <tr><td>2: 9.6 ↘</td></tr> <tr><td>3: 9.7 →</td></tr> <tr><td>4: 7.4 →</td></tr> <tr><td>5: 7.2 ↓</td></tr> <tr><td>Series 41.0</td></tr> <tr><td>Total 136.0</td></tr> </table>	1: 9.4 ↘	2: 9.6 ↘	3: 9.7 →	4: 7.4 →	5: 7.2 ↓	Series 41.0	Total 136.0
1: 9.1 ↗																	
2: 10.1 ←																	
3: 9.6 ↗																	
4: 9.5 ↘																	
5: 9.2 ↓																	
Series 46.0																	
Total 95.0																	
1: 9.4 ↘																	
2: 9.6 ↘																	
3: 9.7 →																	
4: 7.4 →																	
5: 7.2 ↓																	
Series 41.0																	
Total 136.0																	

<p>Sight</p>	<p>1. Series 5 Shots</p>	<table border="1" style="width:100%; border-collapse: collapse;"> <tr><td>1: 9.2 ↙</td></tr> <tr><td>2: *10.5 ↓</td></tr> <tr><td>3: *10.9 ↗</td></tr> <tr><td>Series 29.0</td></tr> <tr><td>Total 136.0</td></tr> </table>	1: 9.2 ↙	2: *10.5 ↓	3: *10.9 ↗	Series 29.0	Total 136.0	<table border="1" style="width:100%; border-collapse: collapse;"> <tr><td>1: 9.9 ↗</td></tr> <tr><td>2: 9.5 →</td></tr> <tr><td>3: 10.1 →</td></tr> <tr><td>4: 10.4 ↘</td></tr> <tr><td>5: 10.2 ↘</td></tr> <tr><td>Series 48.0</td></tr> <tr><td>Total 184.0</td></tr> </table>	1: 9.9 ↗	2: 9.5 →	3: 10.1 →	4: 10.4 ↘	5: 10.2 ↘	Series 48.0	Total 184.0
1: 9.2 ↙															
2: *10.5 ↓															
3: *10.9 ↗															
Series 29.0															
Total 136.0															
1: 9.9 ↗															
2: 9.5 →															
3: 10.1 →															
4: 10.4 ↘															
5: 10.2 ↘															
Series 48.0															
Total 184.0															

<p>4 Series 5 Shots</p>	<table border="1" style="width:100%; border-collapse: collapse;"> <tr><td>1: 10.2 ↙</td></tr> <tr><td>2: 9.7 ↙</td></tr> <tr><td>3: 10.1 ↘</td></tr> <tr><td>4: 9.3 →</td></tr> <tr><td>5: 6.3 →</td></tr> <tr><td>Series 44.0</td></tr> <tr><td>Total 228.0</td></tr> </table>	1: 10.2 ↙	2: 9.7 ↙	3: 10.1 ↘	4: 9.3 →	5: 6.3 →	Series 44.0	Total 228.0
1: 10.2 ↙								
2: 9.7 ↙								
3: 10.1 ↘								
4: 9.3 →								
5: 6.3 →								
Series 44.0								
Total 228.0								

<p>5 Shots Sight</p>	<p>1. Series 5 Shots</p>	
1: 9.6 ← 2: 10.4 ↑ 3: 9.9 ↓ 4: 10.1 ↗ 5: 10.1 ↓	1: 9.9 → 2: 10.3 ← 3: 10.0 ↖ 4: 8.9 → 5: 9.3 ↘	
Series 48.0 Total 0.0	Series 46.0 Total 46.0	

<p>2. Series 5 Shots</p>	<p>3. Series 5 Shots</p>	
1: 9.4 ↑ 2: 9.5 ↓ 3: 10.0 ↗ 4: 9.8 ↑ 5: 10.4 ←	1: 10.2 ↖ 2: *10.7 → 3: 9.4 → 4: 7.8 ← 5: 3.3 ↓	
Series 47.0 Total 93.0	Series 39.0 Total 132.0	

<p>Sight</p>	<p>1. Series 5 Shots</p>	
1: 10.2 → 2: 10.1 ← 3: 10.4 ↓	1: 10.4 ↑ 2: 10.3 → 3: 9.7 ↘ 4: 10.3 ↗ 5: 9.7 ↖	
Series 30.0 Total 132.0	Series 48.0 Total 180.0	

<p>2. Series 5 Shots</p>		
1: 8.7 ↑ 2: 10.4 ← 3: 9.5 ↗ 4: 7.1 ↗ 5: 4.2 ↓		
Series 38.0 Total 218.0		

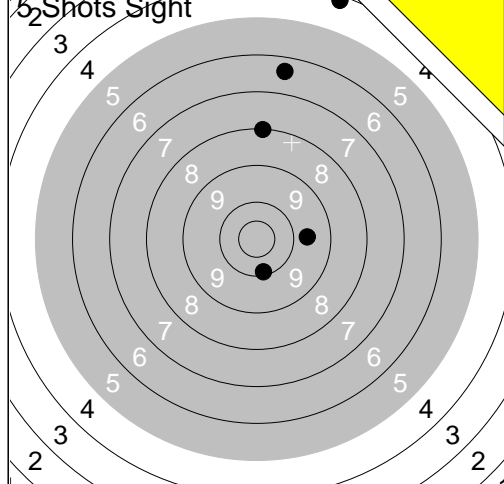

1:	8.1	↑
2:	4.2	↑
3:	6.4	↑
4:	10.1	↓
5:	9.7	→

Series	37.0
Total	0.0

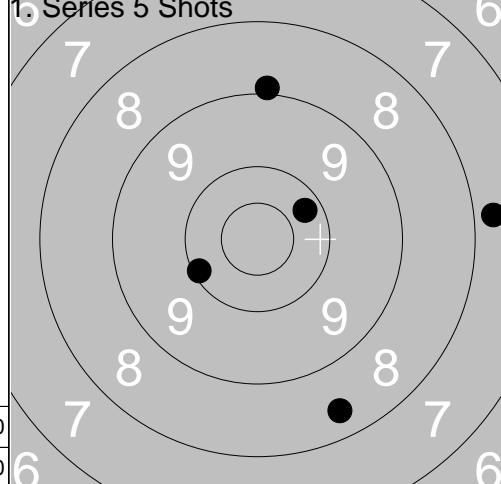

1:	10.2	↗
2:	7.8	→
3:	8.9	↑
4:	10.1	↖
5:	8.4	↓

Series	43.0
Total	43.0

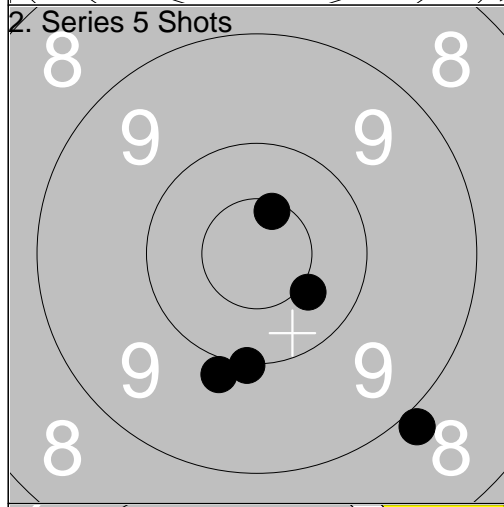

1:	10.0	↓
2:	10.4	↘
3:	8.9	↘
4:	*10.6	↑
5:	9.9	↓

Series	47.0
Total	90.0

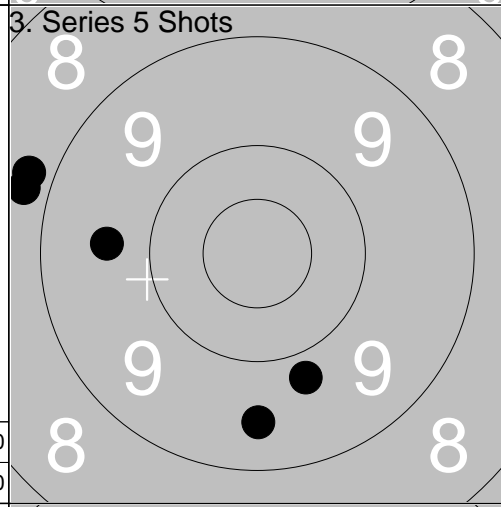

1:	9.5	↓
2:	9.6	←
3:	8.8	↖
4:	8.8	↖
5:	9.8	↓

Series	43.0
Total	133.0

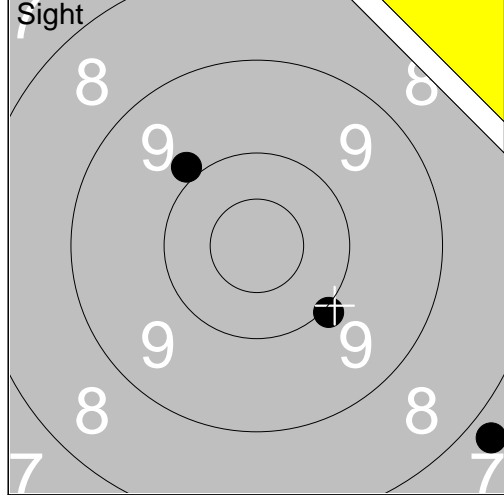

1:	7.8	↘
2:	10.0	↘
3:	9.9	↗

Series	26.0
Total	133.0

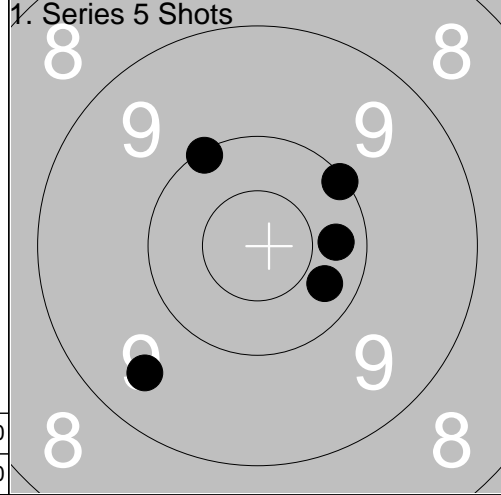

1:	10.1	↗
2:	10.3	↘
3:	10.1	↗
4:	10.3	→
5:	9.5	↓

Series	49.0
Total	182.0

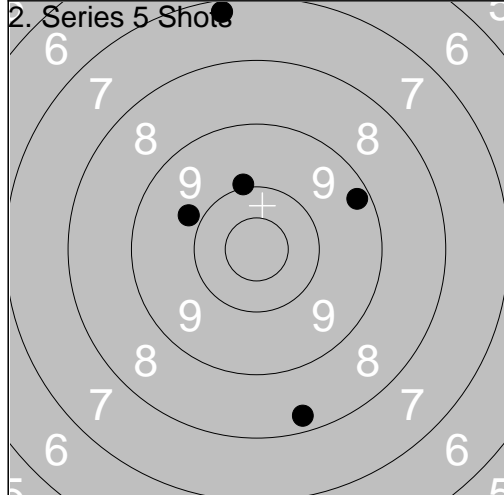

1:	10.0	↑
2:	9.2	↗
3:	9.8	↖
4:	7.2	↑
5:	8.3	↓

Series	43.0
Total	225.0

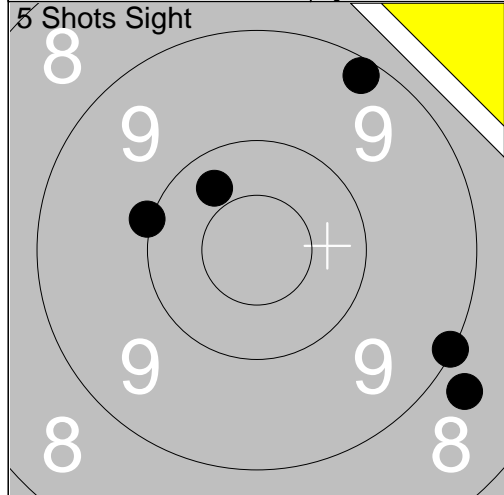

1:	9.1	↘
2:	8.7	↘
3:	10.3	↗
4:	10.0	↖
5:	9.2	↗
Series		46.0
Total		0.0

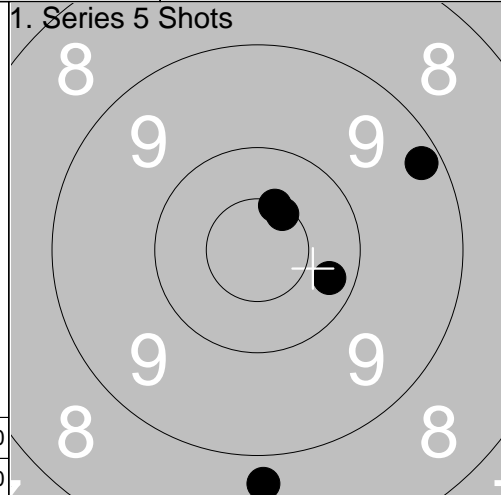

1:	8.8	↓
2:	9.2	↗
3:	*10.6	↗
4:	10.3	↘
5:	*10.5	↗
Series		47.0
Total		47.0

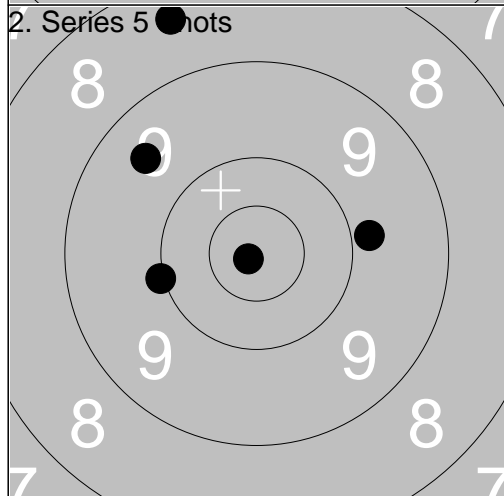

1:	9.5	↖
2:	9.8	→
3:	10.0	←
4:	8.4	↗
5:	*10.9	↖
Series		46.0
Total		93.0

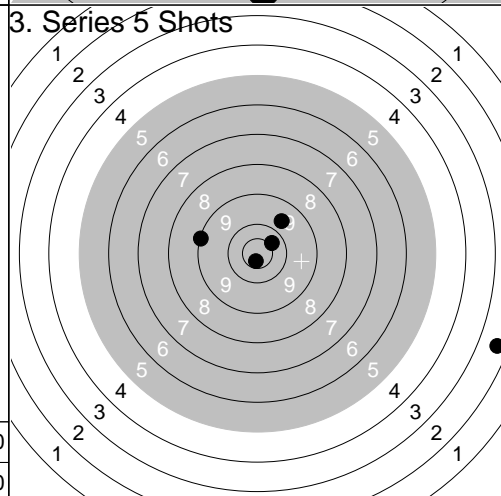

1:	*10.7	↓
2:	9.7	↗
3:	10.4	↗
4:	9.1	←
5:	2.4	→
Series		40.0
Total		133.0

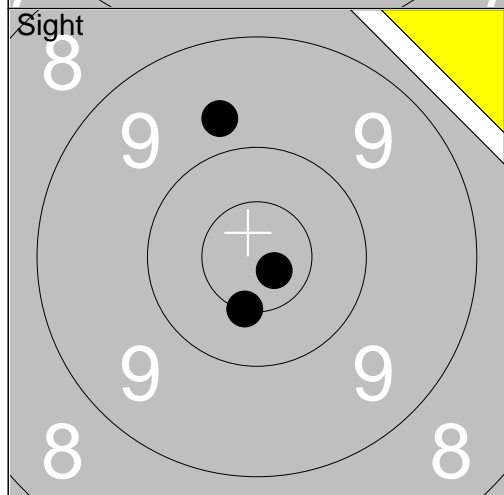

1:	*10.8	↘
2:	9.7	↗
3:	*10.5	↘
Series		29.0
Total		133.0

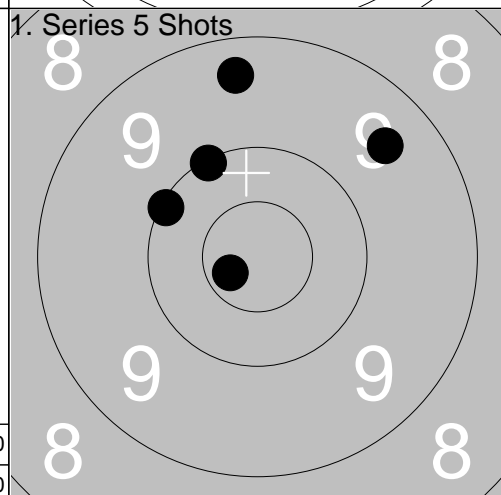

1:	*10.7	←
2:	10.1	↖
3:	9.5	↗
4:	9.4	↗
5:	10.1	↖
Series		48.0
Total		181.0

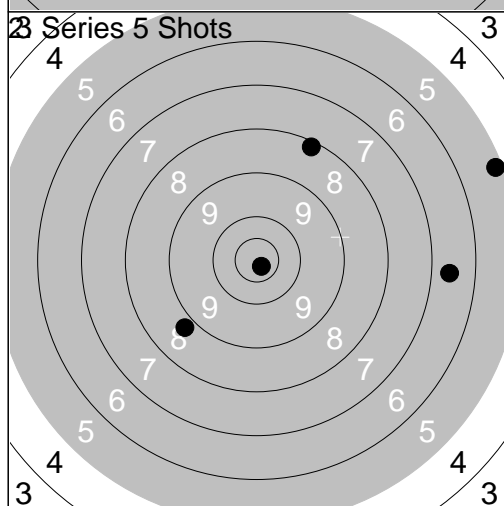

1:	8.2	↗
2:	*10.8	↘
3:	8.8	↖
4:	6.6	→
5:	5.2	→
Series		37.0
Total		218.0

<p>5 Shots Sight</p>	<p>1: 10.4 ↗ 2: *10.5 ↖ 3: 10.2 ← 4: 9.2 ↑ 5: 9.8 ↓</p>	<p>1. Series 5 Shots</p>	<p>1: 8.5 ↖ 2: 10.3 ↖ 3: *10.8 ← 4: *10.8 ↗ 5: *10.5 ↗</p>
Series 48.0		Series 48.0	
Total 0.0		Total 48.0	

<p>2. Series 5 Shots</p>	<p>1: 9.7 ↖ 2: *10.6 ↘ 3: 10.3 ↗ 4: 10.4 ↑ 5: 10.1 ←</p>	<p>3. Series 5 Shots</p>	<p>1: 8.1 ↖ 2: 7.5 ← 3: 9.0 → 4: 5.3 → 5: 9.5 ↗</p>
Series 49.0		Series 38.0	
Total 97.0		Total 135.0	

<p>Sight</p>	<p>1: 9.2 ↖ 2: 8.1 ↖ 3: *10.6 →</p>	<p>1. Series 5 Shots</p>	<p>1: *10.7 ← 2: *10.7 → 3: 9.9 ↗ 4: 9.5 ↑ 5: *10.7 ↘</p>
Series 27.0		Series 48.0	
Total 135.0		Total 183.0	

<p>2. Series 5 Shots</p>	<p>1: 8.5 ↗ 2: 8.5 ← 3: 9.5 ↖ 4: 10.0 ↑ 5: 7.2 ←</p>		
Series 42.0			
Total 225.0			

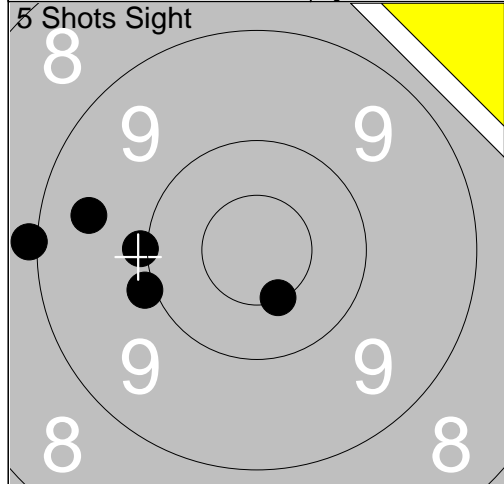

1:	*10.5	↘
2:	10.0	←
3:	9.9	←
4:	9.5	←
5:	9.0	←
Series		47.0
Total		0.0

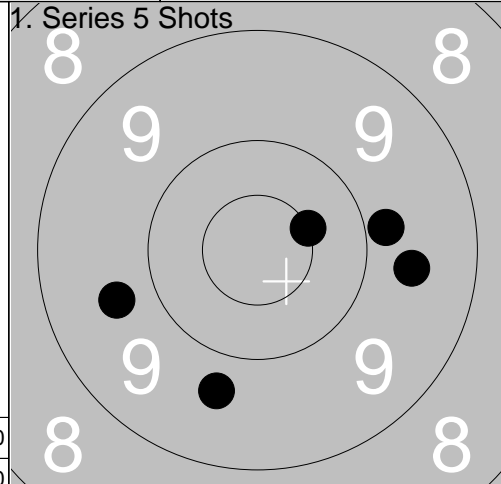

1:	9.7	←
2:	*10.5	→
3:	9.7	↓
4:	9.6	→
5:	9.8	→
Series		46.0
Total		46.0

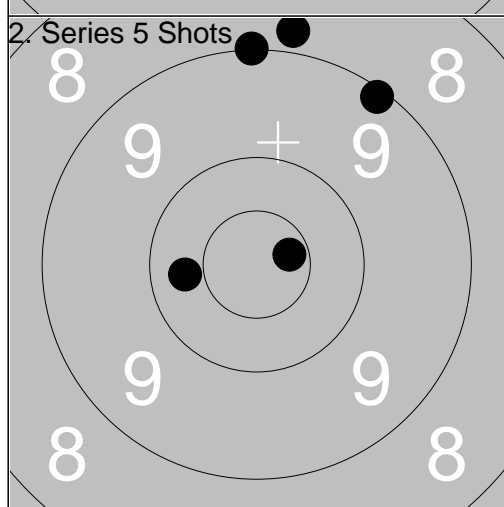

1:	*10.7	→
2:	9.1	↗
3:	9.0	↑
4:	8.8	↑
5:	10.3	←
Series		46.0
Total		92.0

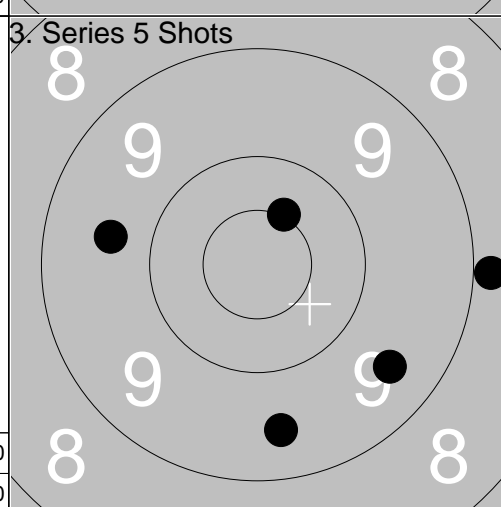

1:	*10.5	↗
2:	9.6	←
3:	9.5	↓
4:	8.9	→
5:	9.5	↘
Series		45.0
Total		137.0

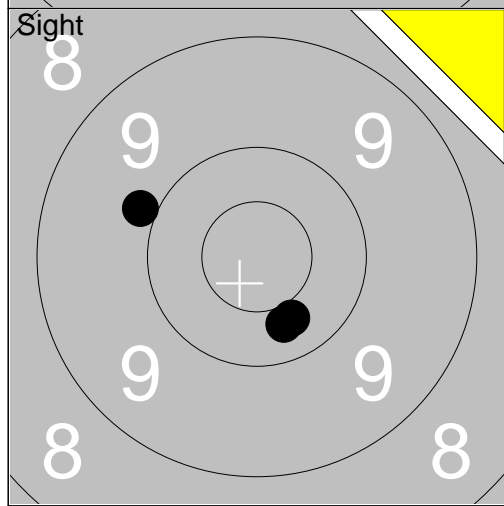

1:	10.3	↘
2:	10.4	↘
3:	9.9	←
Series		29.0
Total		137.0

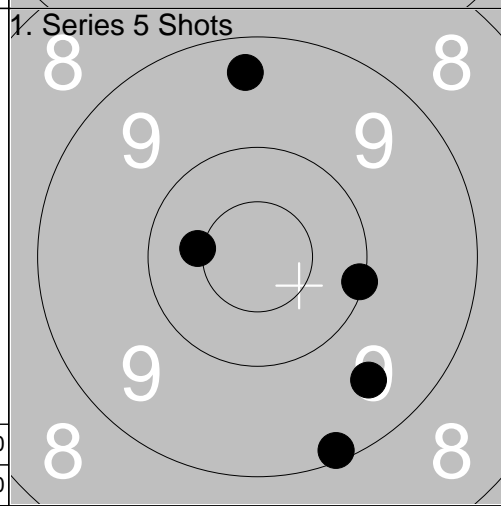

1:	9.4	↑
2:	9.5	↘
3:	10.1	→
4:	*10.4	←
5:	9.1	↘
Series		47.0
Total		184.0

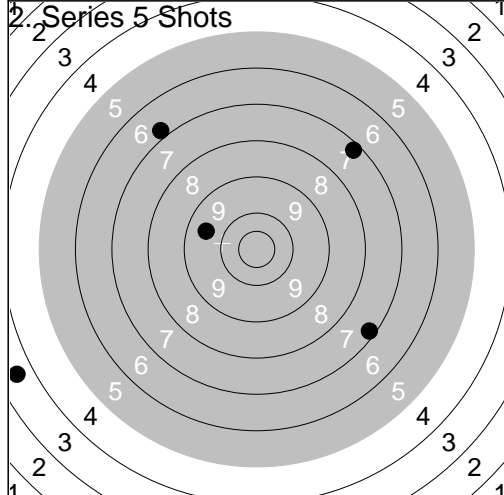

1:	9.5	←
2:	3.6	←
3:	7.2	↗
4:	7.2	↘
5:	6.8	↗
Series		32.0
Total		216.0

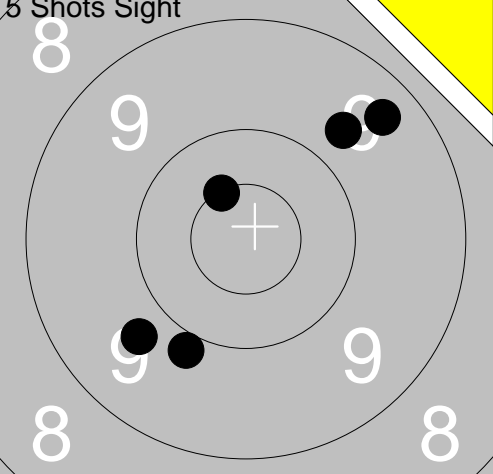
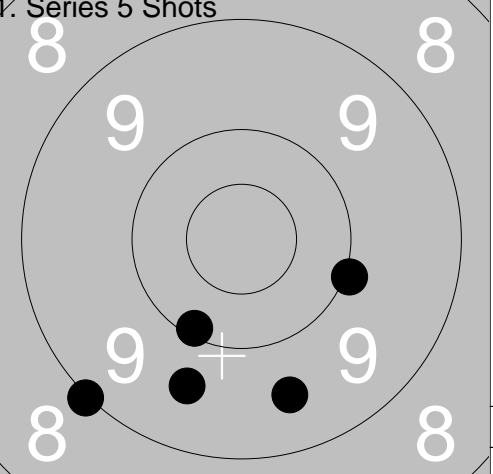
<p>5 Shots Sight</p> 	<p>1: 9.4 ↗ 2: 9.7 ↗ 3: 9.7 ↖ 4: *10.5 ↗ 5: 9.9 ↘</p>	<p>1. Series 5 Shots</p> 	<p>1: 9.5 ↘ 2: 9.6 ↘ 3: 9.0 ↖ 4: 10.1 ↘ 5: 10.0 ↗</p>
Series 46.0		Series 47.0	
Total 0.0		Total 47.0	

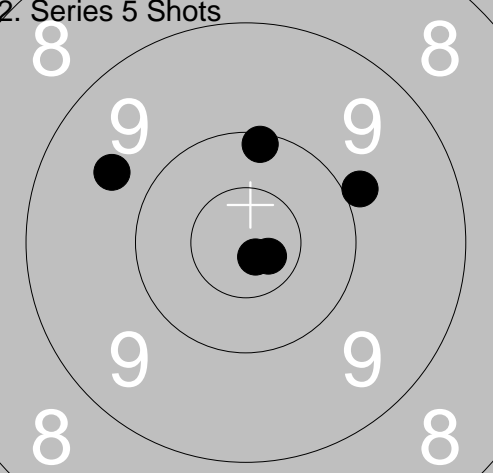
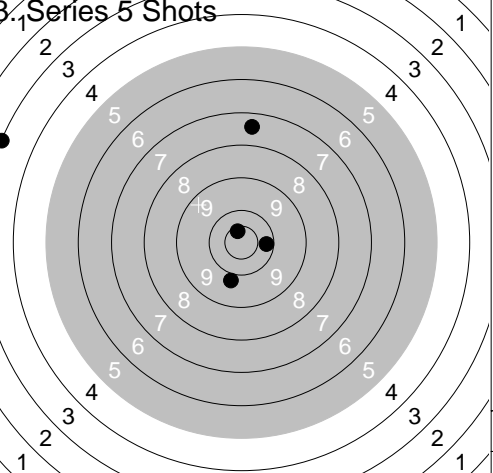
<p>2. Series 5 Shots</p> 	<p>1: 10.1 ↑ 2: *10.7 → 3: 9.7 ↗ 4: *10.8 ↘ 5: 9.9 →</p>	<p>3. Series 5 Shots</p> 	<p>1: *10.6 ↑ 2: 10.2 → 3: 9.8 ↘ 4: 3.0 ↖ 5: 7.5 ↑</p>
Series 48.0		Series 39.0	
Total 95.0		Total 134.0	

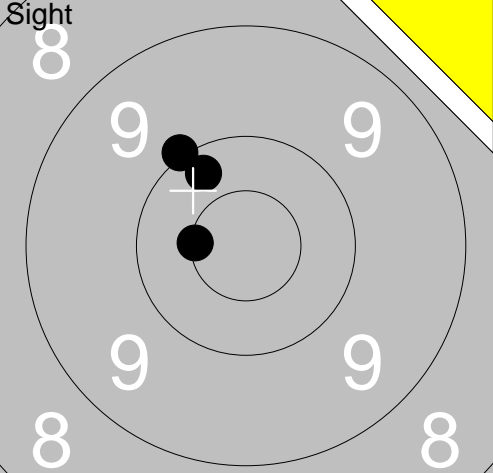
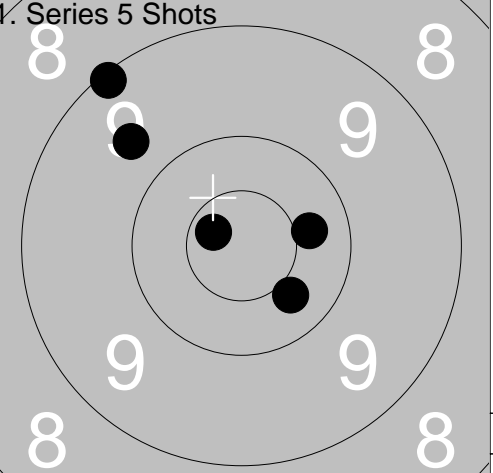
<p>Sight</p> 	<p>1: 10.2 ↗ 2: *10.5 ← 3: 10.0 ↗</p>	<p>1. Series 5 Shots</p> 	<p>1: 9.6 ↗ 2: *10.7 ↖ 3: 9.1 ↗ 4: 10.4 ↘ 5: 10.4 →</p>
Series 30.0		Series 48.0	
Total 134.0		Total 182.0	

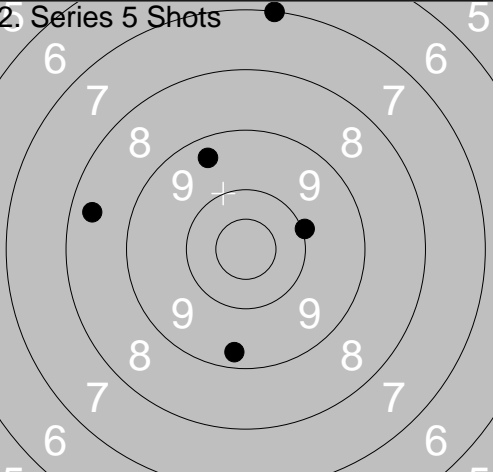
<p>2. Series 5 Shots</p> 	<p>1: 10.0 → 2: 8.4 ← 3: 9.3 ↘ 4: 9.4 ↗ 5: 7.0 ↑</p>		
Series 43.0			
Total 225.0			

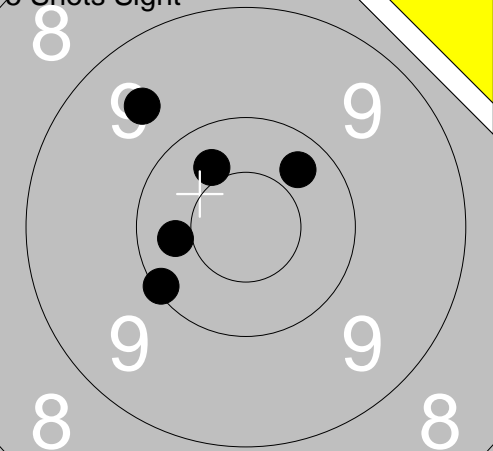
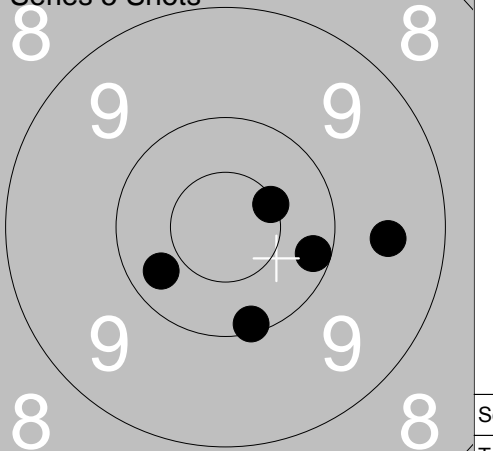
<p>5 Shots Sight</p>  <p>Series 49.0 Total 0.0</p>	<p>1. Series 5 Shots</p>  <p>Series 49.0 Total 49.0</p>	<table border="1" style="width:100%; border-collapse: collapse;"> <tr><td>1:</td><td>10.4</td><td>↗</td></tr> <tr><td>2:</td><td>9.6</td><td>↗</td></tr> <tr><td>3:</td><td>10.3</td><td>↗</td></tr> <tr><td>4:</td><td>10.3</td><td>←</td></tr> <tr><td>5:</td><td>10.1</td><td>↙</td></tr> </table> <table border="1" style="width:100%; border-collapse: collapse;"> <tr><td>1:</td><td>10.2</td><td>→</td></tr> <tr><td>2:</td><td>10.3</td><td>↙</td></tr> <tr><td>3:</td><td>10.1</td><td>↓</td></tr> <tr><td>4:</td><td>*10.5</td><td>↗</td></tr> <tr><td>5:</td><td>9.6</td><td>→</td></tr> </table>	1:	10.4	↗	2:	9.6	↗	3:	10.3	↗	4:	10.3	←	5:	10.1	↙	1:	10.2	→	2:	10.3	↙	3:	10.1	↓	4:	*10.5	↗	5:	9.6	→
1:	10.4	↗																														
2:	9.6	↗																														
3:	10.3	↗																														
4:	10.3	←																														
5:	10.1	↙																														
1:	10.2	→																														
2:	10.3	↙																														
3:	10.1	↓																														
4:	*10.5	↗																														
5:	9.6	→																														

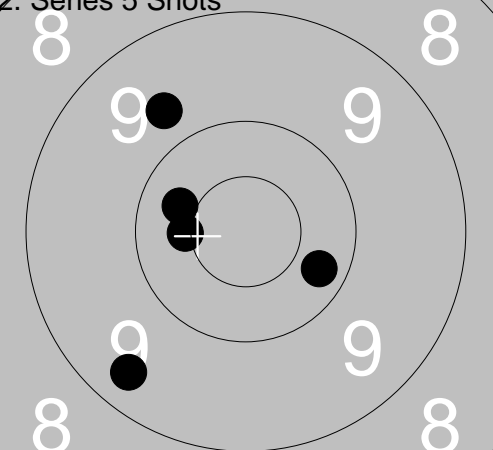
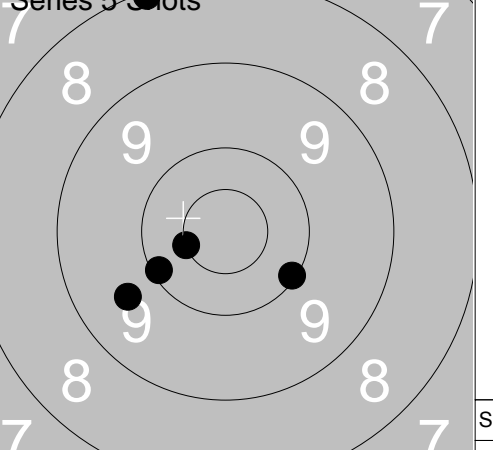
<p>2. Series 5 Shots</p>  <p>Series 48.0 Total 97.0</p>	<p>3. Series 5 Shots</p>  <p>Series 47.0 Total 144.0</p>	<table border="1" style="width:100%; border-collapse: collapse;"> <tr><td>1:</td><td>10.3</td><td>↘</td></tr> <tr><td>2:</td><td>9.4</td><td>↘</td></tr> <tr><td>3:</td><td>*10.4</td><td>←</td></tr> <tr><td>4:</td><td>9.7</td><td>↗</td></tr> <tr><td>5:</td><td>10.4</td><td>↗</td></tr> </table> <table border="1" style="width:100%; border-collapse: collapse;"> <tr><td>1:</td><td>*10.5</td><td>←</td></tr> <tr><td>2:</td><td>10.1</td><td>↙</td></tr> <tr><td>3:</td><td>9.6</td><td>↙</td></tr> <tr><td>4:</td><td>8.1</td><td>↗</td></tr> <tr><td>5:</td><td>10.1</td><td>↘</td></tr> </table>	1:	10.3	↘	2:	9.4	↘	3:	*10.4	←	4:	9.7	↗	5:	10.4	↗	1:	*10.5	←	2:	10.1	↙	3:	9.6	↙	4:	8.1	↗	5:	10.1	↘
1:	10.3	↘																														
2:	9.4	↘																														
3:	*10.4	←																														
4:	9.7	↗																														
5:	10.4	↗																														
1:	*10.5	←																														
2:	10.1	↙																														
3:	9.6	↙																														
4:	8.1	↗																														
5:	10.1	↘																														

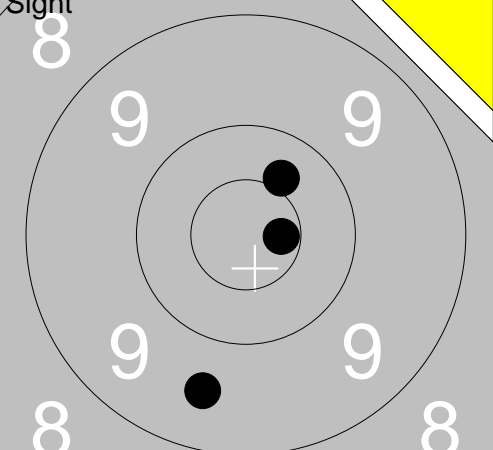
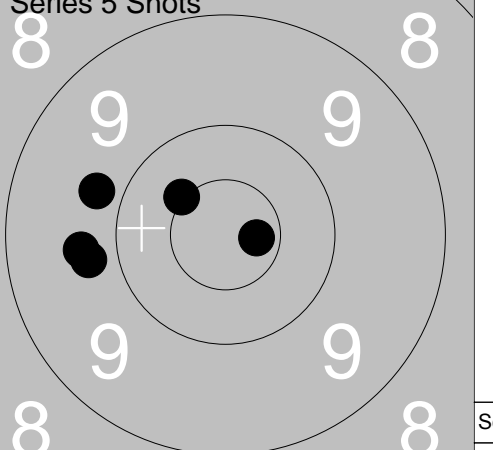
<p>Sight</p>  <p>Series 29.0 Total 144.0</p>	<p>1. Series 5 Shots</p>  <p>Series 47.0 Total 191.0</p>	<table border="1" style="width:100%; border-collapse: collapse;"> <tr><td>1:</td><td>10.4</td><td>↗</td></tr> <tr><td>2:</td><td>*10.7</td><td>→</td></tr> <tr><td>3:</td><td>9.6</td><td>↓</td></tr> </table> <table border="1" style="width:100%; border-collapse: collapse;"> <tr><td>1:</td><td>9.8</td><td>↙</td></tr> <tr><td>2:</td><td>*10.7</td><td>→</td></tr> <tr><td>3:</td><td>9.7</td><td>←</td></tr> <tr><td>4:</td><td>9.8</td><td>←</td></tr> <tr><td>5:</td><td>*10.5</td><td>↗</td></tr> </table>	1:	10.4	↗	2:	*10.7	→	3:	9.6	↓	1:	9.8	↙	2:	*10.7	→	3:	9.7	←	4:	9.8	←	5:	*10.5	↗
1:	10.4	↗																								
2:	*10.7	→																								
3:	9.6	↓																								
1:	9.8	↙																								
2:	*10.7	→																								
3:	9.7	←																								
4:	9.8	←																								
5:	*10.5	↗																								

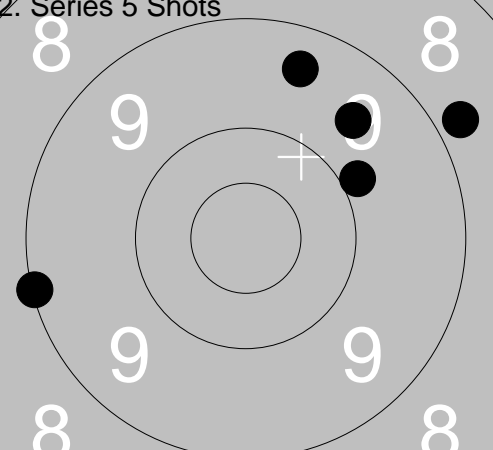
<p>2. Series 5 Shots</p>  <p>Series 44.0 Total 235.0</p>	<table border="1" style="width:100%; border-collapse: collapse;"> <tr><td>1:</td><td>8.8</td><td>↗</td></tr> <tr><td>2:</td><td>9.6</td><td>↗</td></tr> <tr><td>3:</td><td>9.1</td><td>←</td></tr> <tr><td>4:</td><td>9.4</td><td>↑</td></tr> <tr><td>5:</td><td>9.9</td><td>↗</td></tr> </table>	1:	8.8	↗	2:	9.6	↗	3:	9.1	←	4:	9.4	↑	5:	9.9	↗	
1:	8.8	↗															
2:	9.6	↗															
3:	9.1	←															
4:	9.4	↑															
5:	9.9	↗															

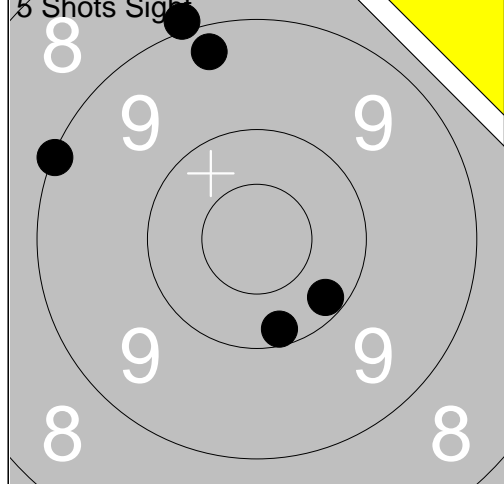

1:	10.2	↘
2:	9.1	↗
3:	10.2	↘
4:	9.3	↗
5:	8.9	↗
Series		46.0
Total		0.0

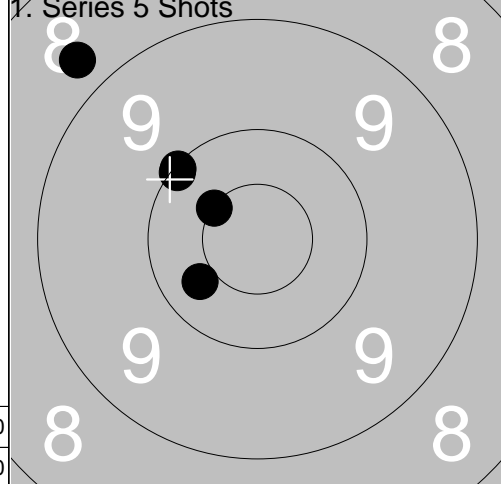

1:	8.7	↗
2:	*10.5	↗
3:	10.1	↗
4:	10.3	↖
5:	10.1	↗
Series		48.0
Total		48.0

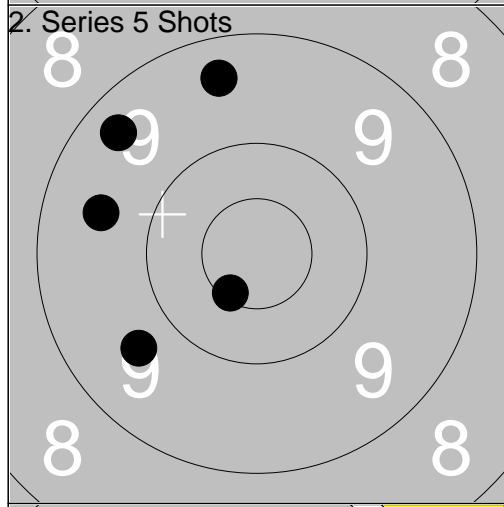

1:	9.4	↖
2:	9.4	↑
3:	*10.6	↘
4:	9.7	↖
5:	9.6	←
Series		46.0
Total		94.0

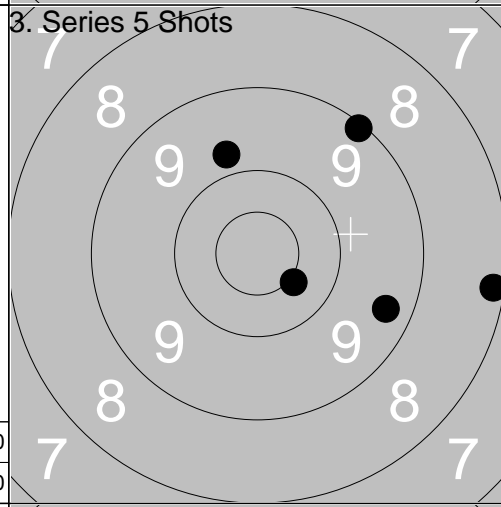

1:	8.2	→
2:	9.3	→
3:	9.8	↑
4:	9.1	↗
5:	*10.4	↘
Series		45.0
Total		139.0

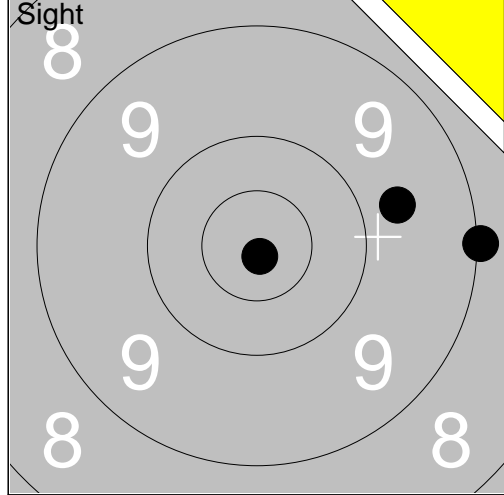

1:	9.7	→
2:	9.0	→
3:	*10.9	↓
Series		28.0
Total		139.0

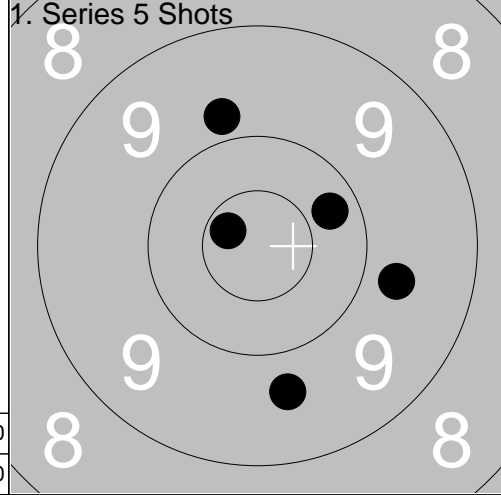

1:	10.3	↗
2:	9.7	→
3:	9.7	↓
4:	*10.7	↖
5:	9.8	↑
Series		47.0
Total		186.0

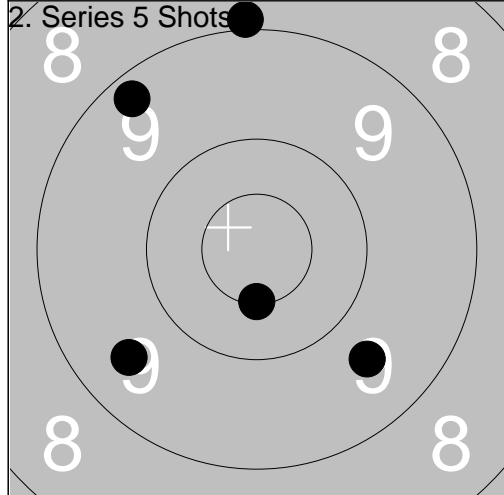

1:	9.6	↘
2:	*10.5	↓
3:	9.3	↗
4:	9.5	↖
5:	8.9	↑
Series		45.0
Total		231.0

<p>5 Shots Sight</p>	<table style="width:100%; border-collapse: collapse;"> <tr><td>1:</td><td>8.4</td><td>↖</td></tr> <tr><td>2:</td><td>8.3</td><td>↗</td></tr> <tr><td>3:</td><td>10.0</td><td>→</td></tr> <tr><td>4:</td><td>9.0</td><td>↑</td></tr> <tr><td>5:</td><td>9.8</td><td>↑</td></tr> </table>	1:	8.4	↖	2:	8.3	↗	3:	10.0	→	4:	9.0	↑	5:	9.8	↑	<p>1. Series 5 Shots</p>	<table style="width:100%; border-collapse: collapse;"> <tr><td>1:</td><td>9.5</td><td>↑</td></tr> <tr><td>2:</td><td>9.6</td><td>↗</td></tr> <tr><td>3:</td><td>*10.8</td><td>↖</td></tr> <tr><td>4:</td><td>8.8</td><td>↖</td></tr> <tr><td>5:</td><td>7.5</td><td>↓</td></tr> </table>	1:	9.5	↑	2:	9.6	↗	3:	*10.8	↖	4:	8.8	↖	5:	7.5	↓
1:	8.4	↖																															
2:	8.3	↗																															
3:	10.0	→																															
4:	9.0	↑																															
5:	9.8	↑																															
1:	9.5	↑																															
2:	9.6	↗																															
3:	*10.8	↖																															
4:	8.8	↖																															
5:	7.5	↓																															
<table style="width:100%; border-collapse: collapse;"> <tr><td style="text-align: right;">Series</td><td style="text-align: right;">44.0</td></tr> <tr><td style="text-align: right;">Total</td><td style="text-align: right;">0.0</td></tr> </table>	Series	44.0	Total	0.0		<table style="width:100%; border-collapse: collapse;"> <tr><td style="text-align: right;">Series</td><td style="text-align: right;">43.0</td></tr> <tr><td style="text-align: right;">Total</td><td style="text-align: right;">43.0</td></tr> </table>	Series	43.0	Total	43.0																							
Series	44.0																																
Total	0.0																																
Series	43.0																																
Total	43.0																																

<p>2. Series 5 Shots</p>	<table style="width:100%; border-collapse: collapse;"> <tr><td>1:</td><td>9.2</td><td>↑</td></tr> <tr><td>2:</td><td>9.4</td><td>↑</td></tr> <tr><td>3:</td><td>10.0</td><td>→</td></tr> <tr><td>4:</td><td>9.4</td><td>←</td></tr> <tr><td>5:</td><td>9.5</td><td>↖</td></tr> </table>	1:	9.2	↑	2:	9.4	↑	3:	10.0	→	4:	9.4	←	5:	9.5	↖	<p>3. Series 5 Shots</p>	<table style="width:100%; border-collapse: collapse;"> <tr><td>1:</td><td>8.6</td><td>↖</td></tr> <tr><td>2:</td><td>8.9</td><td>↘</td></tr> <tr><td>3:</td><td>10.2</td><td>↘</td></tr> <tr><td>4:</td><td>8.6</td><td>←</td></tr> <tr><td>5:</td><td>10.1</td><td>↑</td></tr> </table>	1:	8.6	↖	2:	8.9	↘	3:	10.2	↘	4:	8.6	←	5:	10.1	↑
1:	9.2	↑																															
2:	9.4	↑																															
3:	10.0	→																															
4:	9.4	←																															
5:	9.5	↖																															
1:	8.6	↖																															
2:	8.9	↘																															
3:	10.2	↘																															
4:	8.6	←																															
5:	10.1	↑																															
<table style="width:100%; border-collapse: collapse;"> <tr><td style="text-align: right;">Series</td><td style="text-align: right;">46.0</td></tr> <tr><td style="text-align: right;">Total</td><td style="text-align: right;">89.0</td></tr> </table>	Series	46.0	Total	89.0		<table style="width:100%; border-collapse: collapse;"> <tr><td style="text-align: right;">Series</td><td style="text-align: right;">44.0</td></tr> <tr><td style="text-align: right;">Total</td><td style="text-align: right;">133.0</td></tr> </table>	Series	44.0	Total	133.0																							
Series	46.0																																
Total	89.0																																
Series	44.0																																
Total	133.0																																

<p>Sight</p>	<table style="width:100%; border-collapse: collapse;"> <tr><td>1:</td><td>8.5</td><td>→</td></tr> <tr><td>2:</td><td>9.5</td><td>↗</td></tr> <tr><td>3:</td><td>8.8</td><td>↓</td></tr> </table>	1:	8.5	→	2:	9.5	↗	3:	8.8	↓	<p>1. Series 5 Shots</p>	<table style="width:100%; border-collapse: collapse;"> <tr><td>1:</td><td>9.0</td><td>↑</td></tr> <tr><td>2:</td><td>9.3</td><td>←</td></tr> <tr><td>3:</td><td>9.9</td><td>←</td></tr> <tr><td>4:</td><td>7.7</td><td>←</td></tr> <tr><td>5:</td><td>9.0</td><td>↑</td></tr> </table>	1:	9.0	↑	2:	9.3	←	3:	9.9	←	4:	7.7	←	5:	9.0	↑
1:	8.5	→																									
2:	9.5	↗																									
3:	8.8	↓																									
1:	9.0	↑																									
2:	9.3	←																									
3:	9.9	←																									
4:	7.7	←																									
5:	9.0	↑																									
<table style="width:100%; border-collapse: collapse;"> <tr><td style="text-align: right;">Series</td><td style="text-align: right;">25.0</td></tr> <tr><td style="text-align: right;">Total</td><td style="text-align: right;">133.0</td></tr> </table>	Series	25.0	Total	133.0		<table style="width:100%; border-collapse: collapse;"> <tr><td style="text-align: right;">Series</td><td style="text-align: right;">43.0</td></tr> <tr><td style="text-align: right;">Total</td><td style="text-align: right;">176.0</td></tr> </table>	Series	43.0	Total	176.0																	
Series	25.0																										
Total	133.0																										
Series	43.0																										
Total	176.0																										

<p>2. Series 5 Shots</p>	<table style="width:100%; border-collapse: collapse;"> <tr><td>1:</td><td>10.1</td><td>←</td></tr> <tr><td>2:</td><td>10.1</td><td>↗</td></tr> <tr><td>3:</td><td>7.9</td><td>↑</td></tr> <tr><td>4:</td><td>8.9</td><td>↗</td></tr> <tr><td>5:</td><td>10.1</td><td>↗</td></tr> </table>	1:	10.1	←	2:	10.1	↗	3:	7.9	↑	4:	8.9	↗	5:	10.1	↗		
1:	10.1	←																
2:	10.1	↗																
3:	7.9	↑																
4:	8.9	↗																
5:	10.1	↗																
<table style="width:100%; border-collapse: collapse;"> <tr><td style="text-align: right;">Series</td><td style="text-align: right;">45.0</td></tr> <tr><td style="text-align: right;">Total</td><td style="text-align: right;">221.0</td></tr> </table>	Series	45.0	Total	221.0														
Series	45.0																	
Total	221.0																	



1:	7.4	↗
2:	8.2	→
3:	9.7	→
4:	9.8	↖
5:	7.1	←

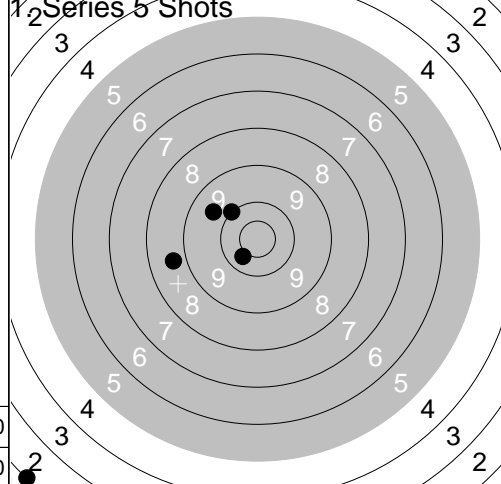

1:	9.6	↖
2:	8.7	←
3:	2.1	↘
4:	10.4	↘
5:	10.0	↗

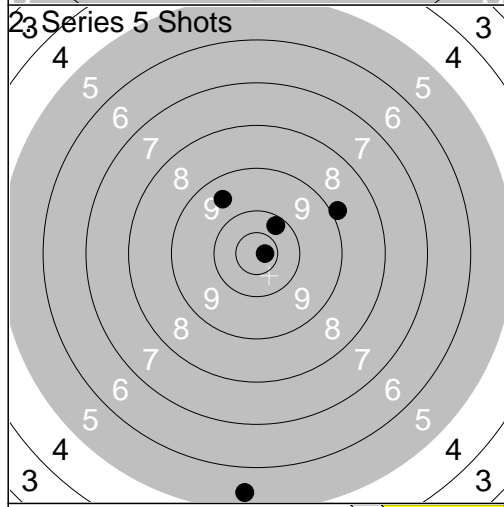

1:	8.9	↗
2:	9.5	↖
3:	5.4	↓
4:	10.2	↗
5:	*10.8	→

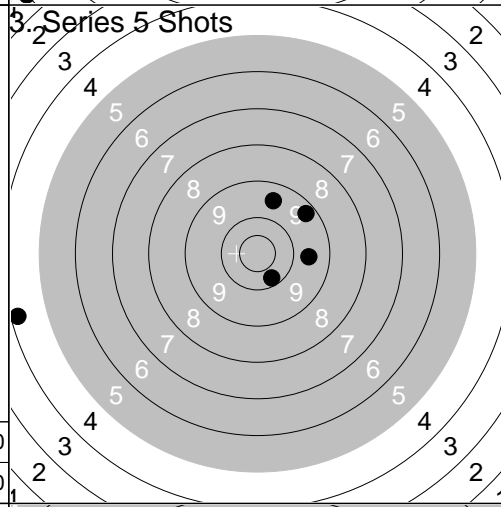

1:	4.2	←
2:	9.6	→
3:	9.5	↑
4:	9.3	↗
5:	10.2	↘

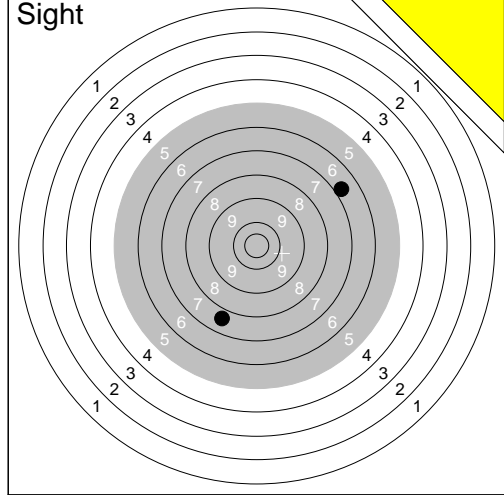

2:	6.7	↗
3:	7.6	↘

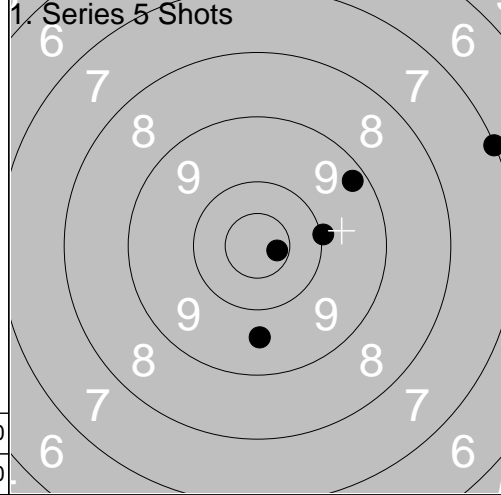

1:	*10.7	→
2:	9.6	↓
3:	10.0	→
4:	7.0	↗
5:	9.2	↗

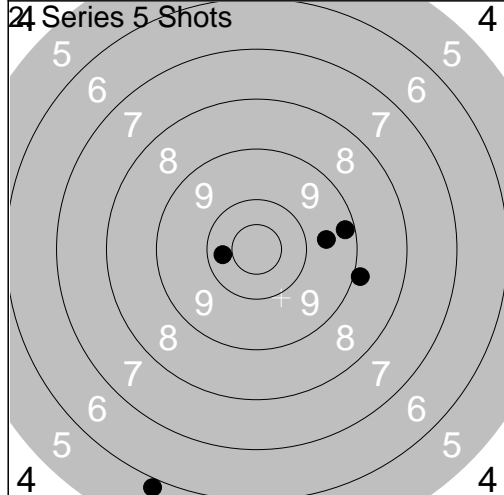

1:	9.2	→
2:	5.8	↘
3:	8.9	→
4:	9.6	→
5:	10.3	←

Series	40.0
Total	0.0
Series	42.0
Total	81.0
Series	13.0
Total	122.0
Series	39.0
Total	39.0
Series	41.0
Total	122.0
Series	45.0
Total	167.0
Series	41.0
Total	208.0

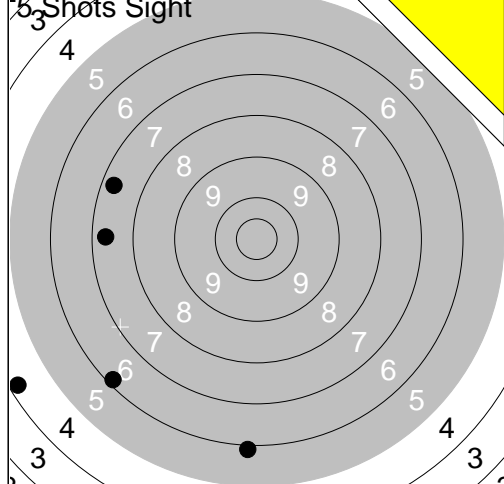

1:	6.2	↙
2:	7.4	←
3:	7.3	↖
4:	4.3	↙
5:	5.9	↓
Series		29.0
Total		0.0

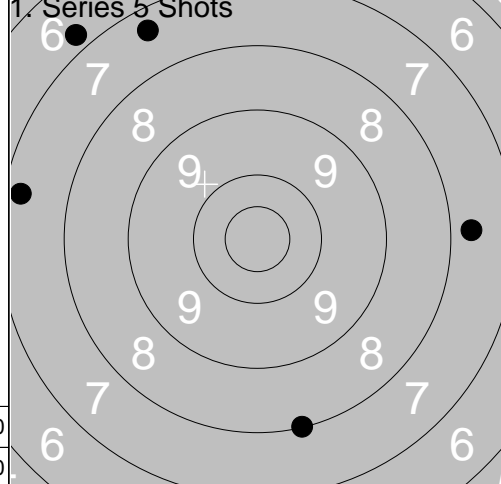

1:	7.3	←
2:	7.7	→
3:	6.8	↗
4:	7.4	↗
5:	8.0	↓
Series		35.0
Total		35.0

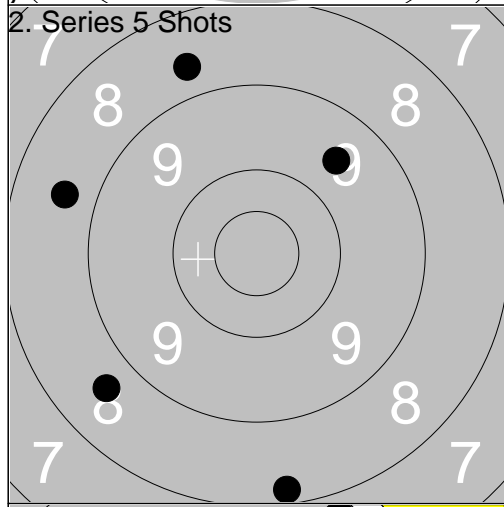

1:	8.6	↙
2:	8.2	↓
3:	8.6	←
4:	8.7	↑
5:	9.6	↗
Series		41.0
Total		76.0

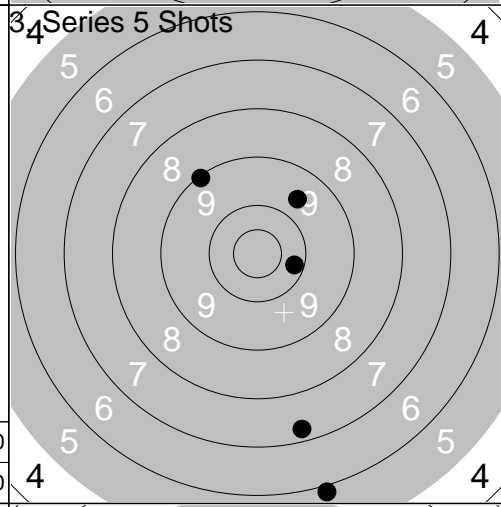

1:	9.1	↗
2:	9.6	↗
3:	7.3	↓
4:	10.2	→
5:	5.9	↓
Series		40.0
Total		116.0

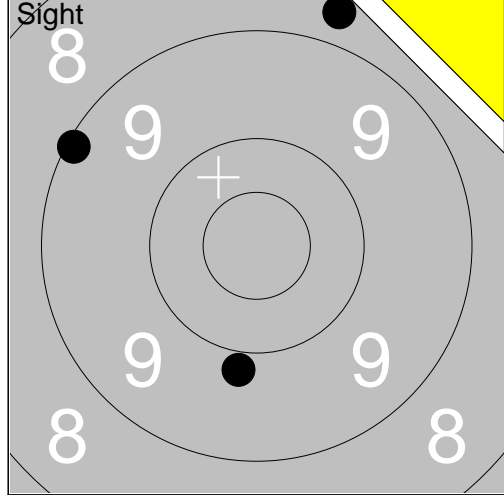

1:	8.7	↑
2:	9.1	↖
3:	9.9	↓
Series		26.0
Total		116.0

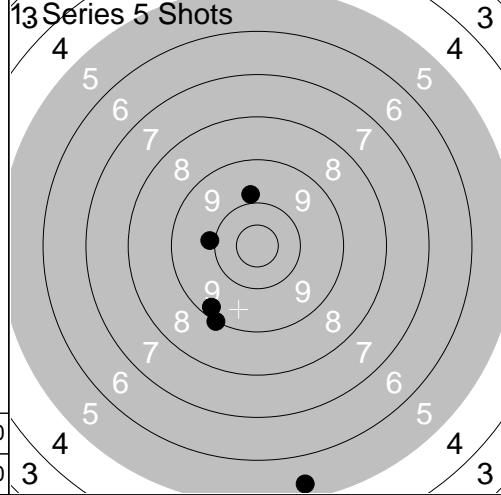

1:	9.9	←
2:	9.8	↑
3:	5.4	↓
4:	9.0	↙
5:	9.2	↙
Series		41.0
Total		157.0

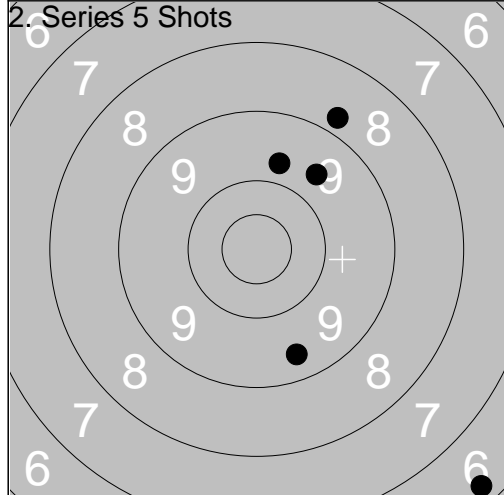

1:	9.4	↓
2:	9.7	↑
3:	6.3	↘
4:	9.6	↗
5:	8.8	↗
Series		41.0
Total		198.0

<p>5 Shots Sight</p>	<p>1: 8.6 ↙ 2: 9.0 ↙ 3: 9.7 ↗ 4: 9.7 ↗ 5: 9.5 ↗</p>	<p>1. Series 5 Shots</p>	<p>1: 9.8 ↗ 2: 9.8 ↓ 3: 9.6 ↙ 4: 9.7 ↙ 5: 10.0 ←</p>
Series 44.0		Series 46.0	
Total 0.0		Total 46.0	

<p>2. Series 5 Shots</p>	<p>1: 8.7 ↖ 2: 10.2 ↙ 3: 9.6 ↗ 4: 10.1 ↙ 5: 9.2 ←</p>	<p>3. Series 5 Shots</p>	<p>1: 8.1 → 2: 9.6 ↙ 3: 10.1 ↙ 4: 8.9 ↑ 5: 10.3 ↗</p>
Series 46.0		Series 45.0	
Total 92.0		Total 137.0	

<p>Sight</p>	<p>1: 8.1 → 2: 9.2 ← 3: 8.9 ↓</p>	<p>1. Series 5 Shots</p>	<p>1: 9.0 ← 2: 10.1 ↗ 3: *10.5 ↗ 4: 10.1 ← 5: 9.6 ↙</p>
Series 25.0		Series 48.0	
Total 137.0		Total 185.0	

<p>2. Series 5 Shots</p>	<p>1: 10.3 ← 2: 9.1 ↘ 3: 7.6 → 4: 7.0 ↘ 5: 7.8 ↘</p>		
Series 40.0			
Total 225.0			



1:	9.2	↖
2:	8.4	↑
3:	10.1	↗
4:	*10.6	→
5:	*10.6	↖
Series		47.0
Total		0.0

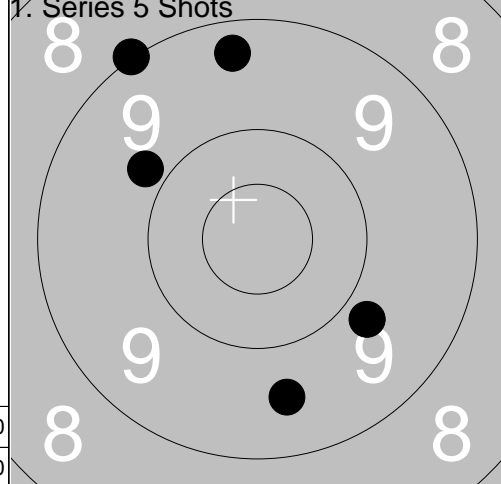

1:	9.3	↑
2:	9.8	↖
3:	9.0	↗
4:	9.8	↘
5:	9.6	↓
Series		45.0
Total		45.0

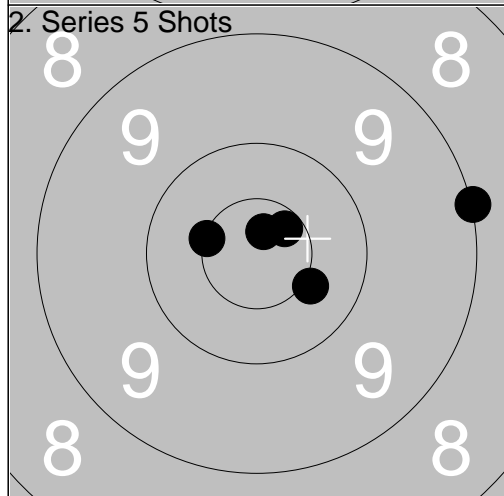

1:	*10.4	↘
2:	9.0	→
3:	*10.6	↗
4:	*10.8	↑
5:	*10.5	↖
Series		49.0
Total		94.0



1:	6.4	↗
2:	7.3	↑
3:	2.5	↘
4:	4.6	↓
5:	6.8	↖
Series		25.0
Total		119.0

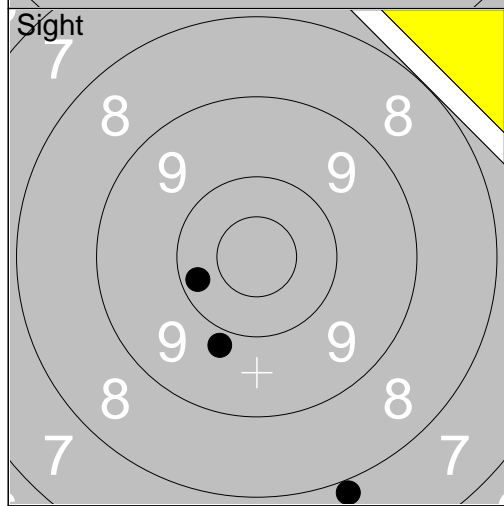

1:	9.8	↓
2:	7.9	↓
3:	10.2	↖
Series		26.0
Total		119.0

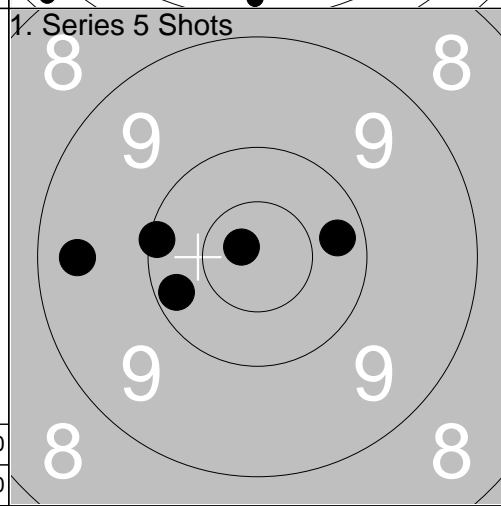

1:	10.2	↖
2:	9.4	↖
3:	*10.8	↖
4:	10.1	↖
5:	10.3	→
Series		49.0
Total		168.0

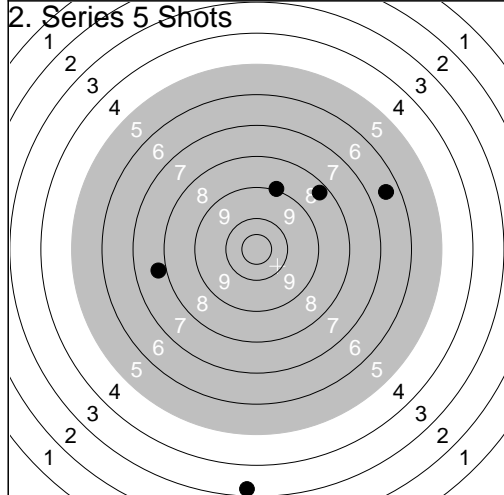

1:	6.5	→
2:	9.0	↑
3:	7.8	↖
4:	8.3	↗
5:	3.3	↓
Series		33.0
Total		201.0

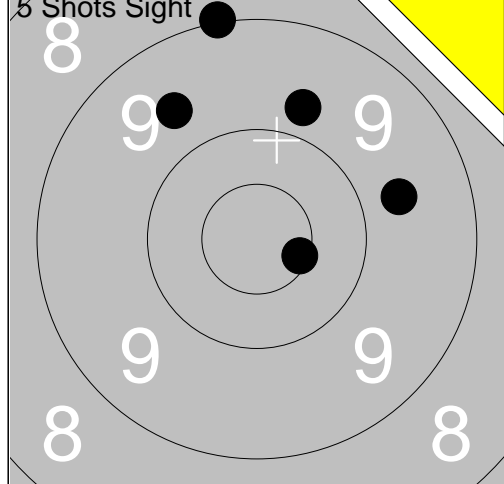

1:	9.6	↗
2:	9.8	↑
3:	*10.6	→
4:	9.0	↑
5:	9.7	→
Series		46.0
Total		0.0

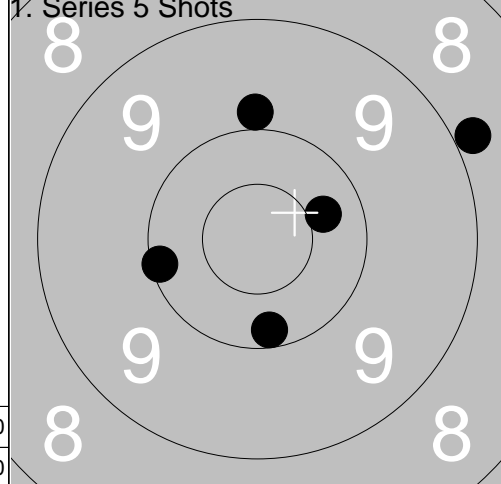

1:	10.4	→
2:	9.9	↑
3:	8.9	↗
4:	10.2	↓
5:	10.1	←
Series		47.0
Total		47.0

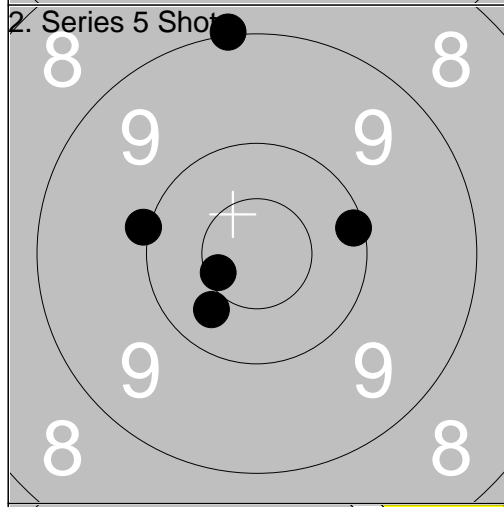

1:	*10.6	←
2:	10.0	←
3:	9.0	↑
4:	10.3	↙
5:	10.1	→
Series		49.0
Total		96.0

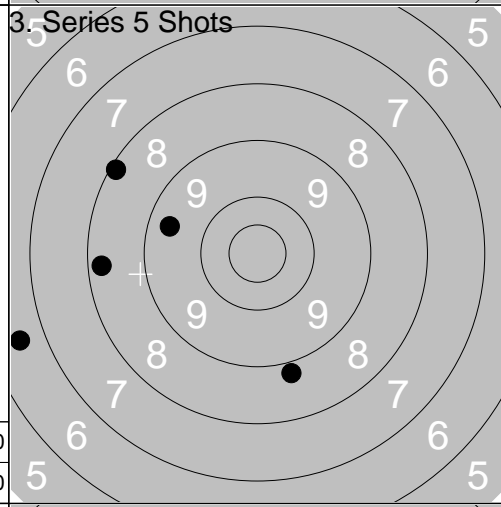

1:	9.4	←
2:	8.1	↖
3:	6.6	←
4:	8.8	↓
5:	8.3	←
Series		39.0
Total		135.0

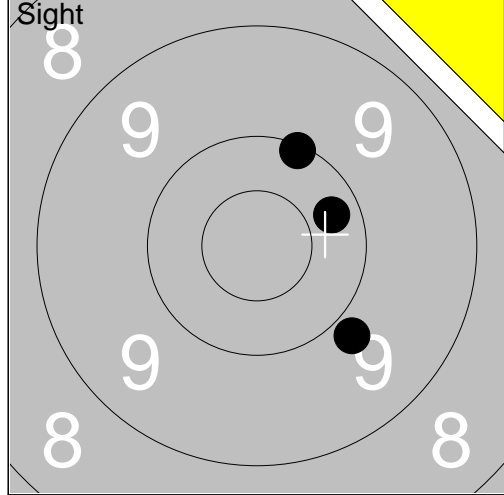

1:	10.3	→
2:	10.1	↑
3:	9.8	↘
Series		29.0
Total		135.0

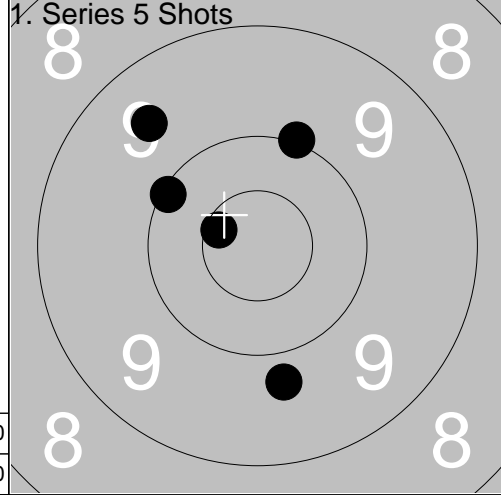

1:	*10.6	←
2:	9.8	↓
3:	9.5	↗
4:	10.1	↖
5:	10.0	↑
Series		48.0
Total		183.0

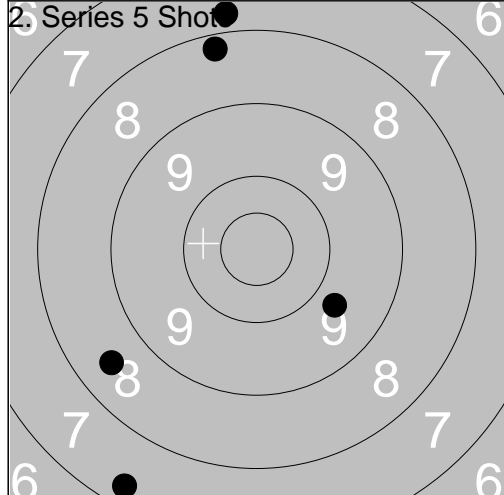

1:	8.2	↑
2:	8.5	↙
3:	9.7	↘
4:	7.8	↑
5:	7.3	↘
Series		39.0
Total		222.0

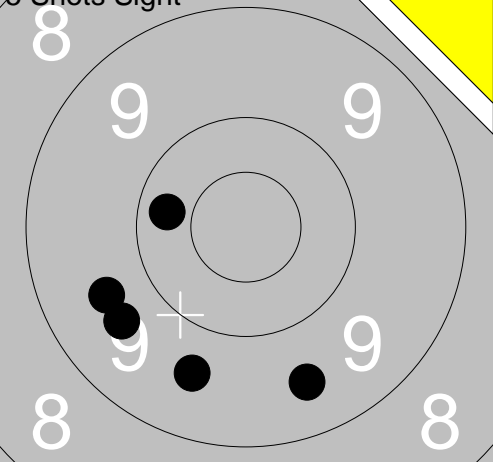
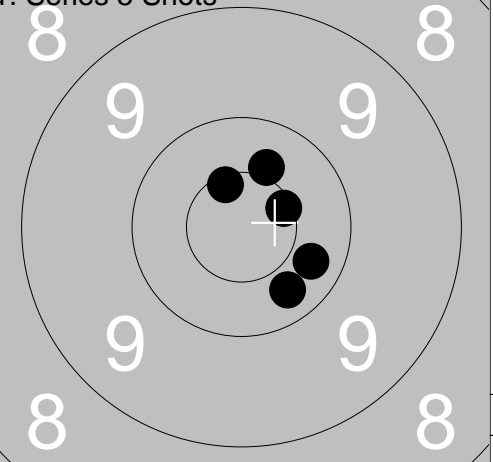
5 Shots Sight 	<table border="1" style="width:100%; border-collapse: collapse;"> <tr><td>1:</td><td>10.3</td><td>←</td></tr> <tr><td>2:</td><td>9.6</td><td>←</td></tr> <tr><td>3:</td><td>9.6</td><td>←</td></tr> <tr><td>4:</td><td>9.5</td><td>↓</td></tr> <tr><td>5:</td><td>9.6</td><td>↓</td></tr> <tr><td colspan="2">Series</td><td>46.0</td></tr> <tr><td colspan="2">Total</td><td>0.0</td></tr> </table>	1:	10.3	←	2:	9.6	←	3:	9.6	←	4:	9.5	↓	5:	9.6	↓	Series		46.0	Total		0.0	1. Series 5 Shots 		<table border="1" style="width:100%; border-collapse: collapse;"> <tr><td>1:</td><td>*10.6</td><td>→</td></tr> <tr><td>2:</td><td>10.3</td><td>↓</td></tr> <tr><td>3:</td><td>10.4</td><td>↑</td></tr> <tr><td>4:</td><td>*10.6</td><td>↑</td></tr> <tr><td>5:</td><td>10.3</td><td>↓</td></tr> <tr><td colspan="2">Series</td><td>50.0</td></tr> <tr><td colspan="2">Total</td><td>50.0</td></tr> </table>	1:	*10.6	→	2:	10.3	↓	3:	10.4	↑	4:	*10.6	↑	5:	10.3	↓	Series		50.0	Total		50.0
1:	10.3	←																																												
2:	9.6	←																																												
3:	9.6	←																																												
4:	9.5	↓																																												
5:	9.6	↓																																												
Series		46.0																																												
Total		0.0																																												
1:	*10.6	→																																												
2:	10.3	↓																																												
3:	10.4	↑																																												
4:	*10.6	↑																																												
5:	10.3	↓																																												
Series		50.0																																												
Total		50.0																																												

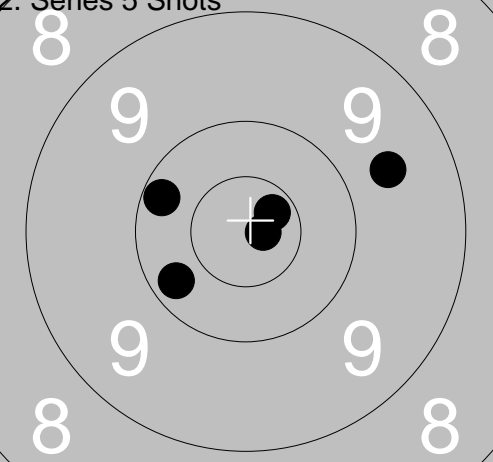
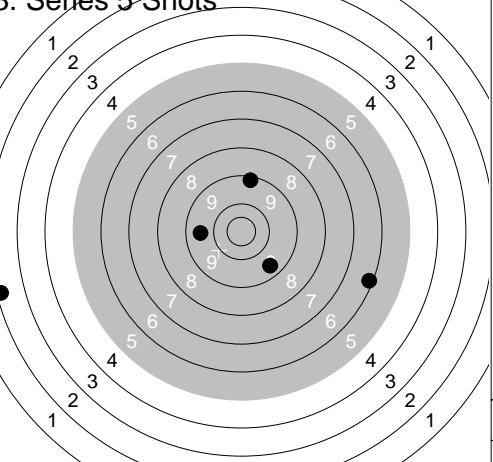
2. Series 5 Shots 	<table border="1" style="width:100%; border-collapse: collapse;"> <tr><td>1:</td><td>*10.7</td><td>→</td></tr> <tr><td>2:</td><td>9.6</td><td>→</td></tr> <tr><td>3:</td><td>10.2</td><td>←</td></tr> <tr><td>4:</td><td>*10.8</td><td>→</td></tr> <tr><td>5:</td><td>10.2</td><td>←</td></tr> <tr><td colspan="2">Series</td><td>49.0</td></tr> <tr><td colspan="2">Total</td><td>99.0</td></tr> </table>	1:	*10.7	→	2:	9.6	→	3:	10.2	←	4:	*10.8	→	5:	10.2	←	Series		49.0	Total		99.0	3. Series 5 Shots 		<table border="1" style="width:100%; border-collapse: collapse;"> <tr><td>1:</td><td>9.2</td><td>↑</td></tr> <tr><td>2:</td><td>9.4</td><td>↓</td></tr> <tr><td>3:</td><td>9.6</td><td>←</td></tr> <tr><td>4:</td><td>6.1</td><td>→</td></tr> <tr><td>5:</td><td>2.2</td><td>←</td></tr> <tr><td colspan="2">Series</td><td>35.0</td></tr> <tr><td colspan="2">Total</td><td>134.0</td></tr> </table>	1:	9.2	↑	2:	9.4	↓	3:	9.6	←	4:	6.1	→	5:	2.2	←	Series		35.0	Total		134.0
1:	*10.7	→																																												
2:	9.6	→																																												
3:	10.2	←																																												
4:	*10.8	→																																												
5:	10.2	←																																												
Series		49.0																																												
Total		99.0																																												
1:	9.2	↑																																												
2:	9.4	↓																																												
3:	9.6	←																																												
4:	6.1	→																																												
5:	2.2	←																																												
Series		35.0																																												
Total		134.0																																												

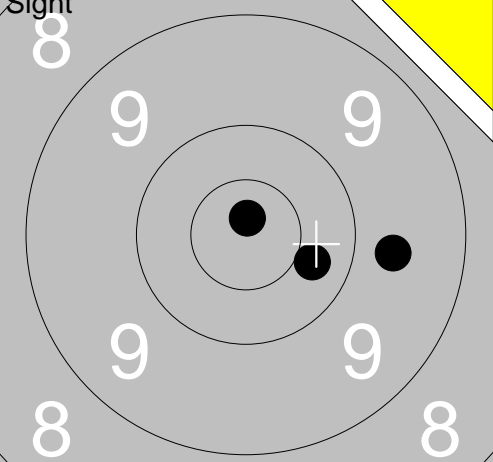
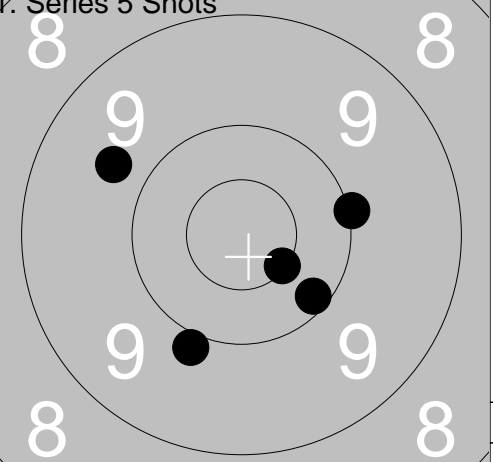
Sight 	<table border="1" style="width:100%; border-collapse: collapse;"> <tr><td>1:</td><td>*10.8</td><td>↑</td></tr> <tr><td>2:</td><td>9.7</td><td>→</td></tr> <tr><td>3:</td><td>10.3</td><td>→</td></tr> <tr><td colspan="2">Series</td><td>29.0</td></tr> <tr><td colspan="2">Total</td><td>134.0</td></tr> </table>	1:	*10.8	↑	2:	9.7	→	3:	10.3	→	Series		29.0	Total		134.0	1. Series 5 Shots 		<table border="1" style="width:100%; border-collapse: collapse;"> <tr><td>1:</td><td>9.9</td><td>↓</td></tr> <tr><td>2:</td><td>10.0</td><td>→</td></tr> <tr><td>3:</td><td>9.7</td><td>↑</td></tr> <tr><td>4:</td><td>*10.5</td><td>↓</td></tr> <tr><td>5:</td><td>10.2</td><td>↓</td></tr> <tr><td colspan="2">Series</td><td>48.0</td></tr> <tr><td colspan="2">Total</td><td>182.0</td></tr> </table>	1:	9.9	↓	2:	10.0	→	3:	9.7	↑	4:	*10.5	↓	5:	10.2	↓	Series		48.0	Total		182.0
1:	*10.8	↑																																						
2:	9.7	→																																						
3:	10.3	→																																						
Series		29.0																																						
Total		134.0																																						
1:	9.9	↓																																						
2:	10.0	→																																						
3:	9.7	↑																																						
4:	*10.5	↓																																						
5:	10.2	↓																																						
Series		48.0																																						
Total		182.0																																						

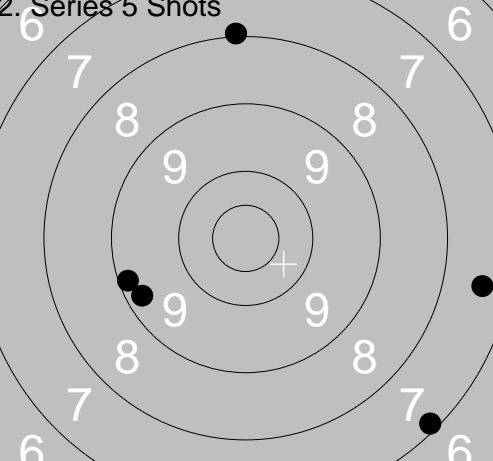
2. Series 5 Shots 	<table border="1" style="width:100%; border-collapse: collapse;"> <tr><td>1:</td><td>9.2</td><td>←</td></tr> <tr><td>2:</td><td>7.4</td><td>→</td></tr> <tr><td>3:</td><td>7.1</td><td>↓</td></tr> <tr><td>4:</td><td>8.0</td><td>↑</td></tr> <tr><td>5:</td><td>9.3</td><td>←</td></tr> <tr><td colspan="2">Series</td><td>40.0</td></tr> <tr><td colspan="2">Total</td><td>222.0</td></tr> </table>	1:	9.2	←	2:	7.4	→	3:	7.1	↓	4:	8.0	↑	5:	9.3	←	Series		40.0	Total		222.0			
1:	9.2	←																							
2:	7.4	→																							
3:	7.1	↓																							
4:	8.0	↑																							
5:	9.3	←																							
Series		40.0																							
Total		222.0																							

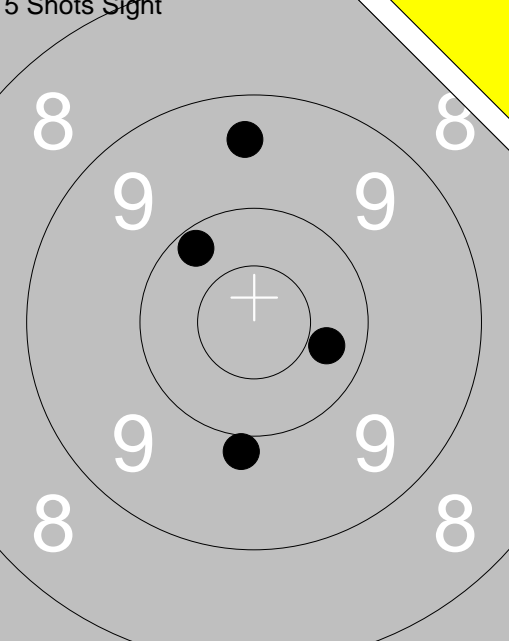
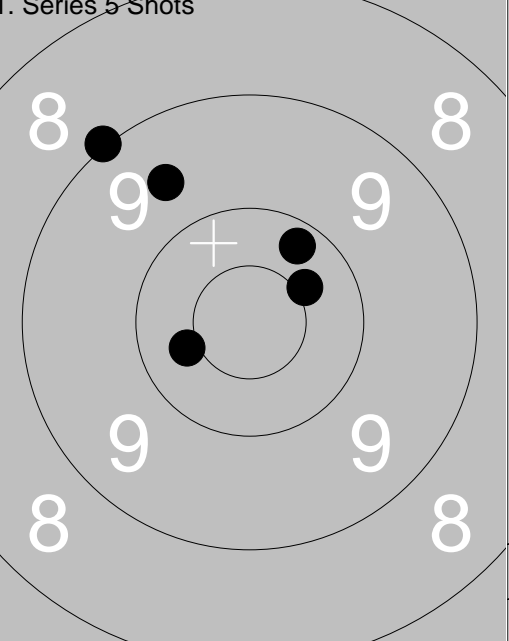
<p>5 Shots Sight</p> 	<p>1: 9.4 ↑ 2: 10.2 ↖ 3: 9.9 ↓ 4: 10.3 →</p>	<p>1. Series 5 Shots</p> 		<p>1: 10.4 ↖ 2: 10.2 ↗ 3: 9.0 ↖ 4: 9.6 ↖ 5: *10.4 ↗</p>								
<table border="1" style="width:100%; border-collapse: collapse;"> <tr><td>Series</td><td style="text-align: right;">38.0</td></tr> <tr><td>Total</td><td style="text-align: right;">0.0</td></tr> </table>		Series	38.0	Total	0.0			<table border="1" style="width:100%; border-collapse: collapse;"> <tr><td>Series</td><td style="text-align: right;">48.0</td></tr> <tr><td>Total</td><td style="text-align: right;">48.0</td></tr> </table>	Series	48.0	Total	48.0
Series	38.0											
Total	0.0											
Series	48.0											
Total	48.0											

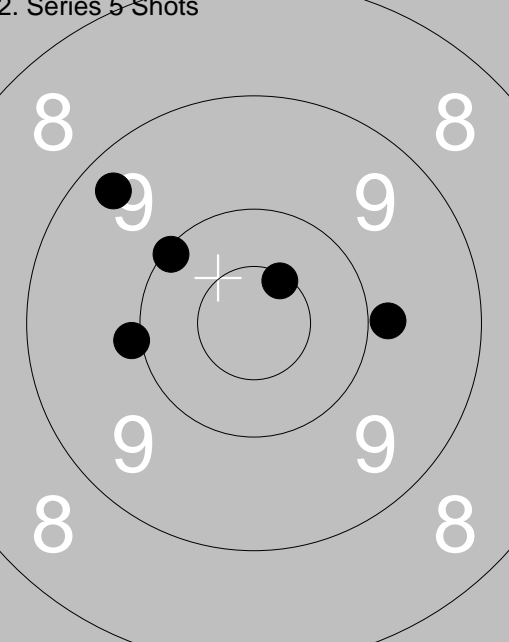
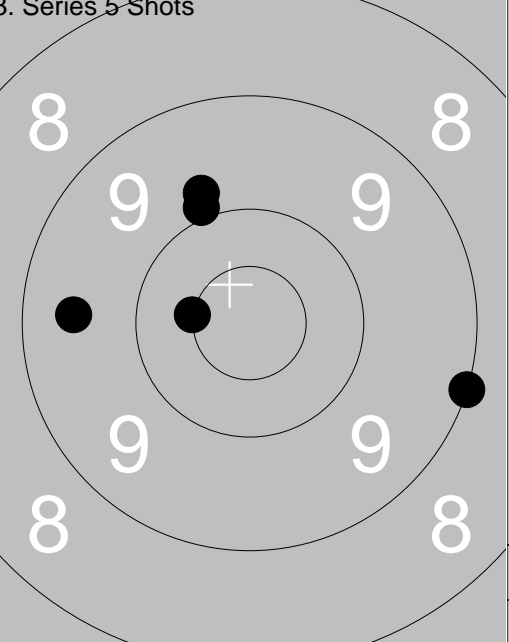
<p>2. Series 5 Shots</p> 	<p>1: 10.1 ↖ 2: 9.9 ← 3: *10.5 ↗ 4: 9.3 ↖ 5: 9.9 →</p>	<p>3. Series 5 Shots</p> 		<p>1: 9.9 ↖ 2: *10.5 ↖ 3: 9.0 → 4: 9.8 ↖ 5: 9.5 ←</p>								
<table border="1" style="width:100%; border-collapse: collapse;"> <tr><td>Series</td><td style="text-align: right;">47.0</td></tr> <tr><td>Total</td><td style="text-align: right;">95.0</td></tr> </table>		Series	47.0	Total	95.0			<table border="1" style="width:100%; border-collapse: collapse;"> <tr><td>Series</td><td style="text-align: right;">46.0</td></tr> <tr><td>Total</td><td style="text-align: right;">141.0</td></tr> </table>	Series	46.0	Total	141.0
Series	47.0											
Total	95.0											
Series	46.0											
Total	141.0											

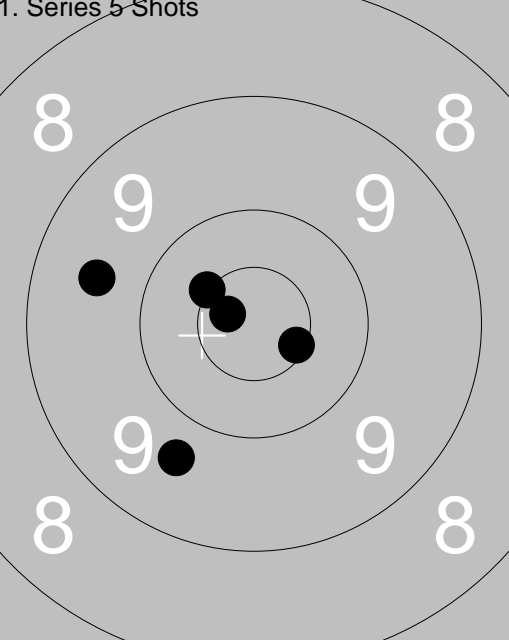
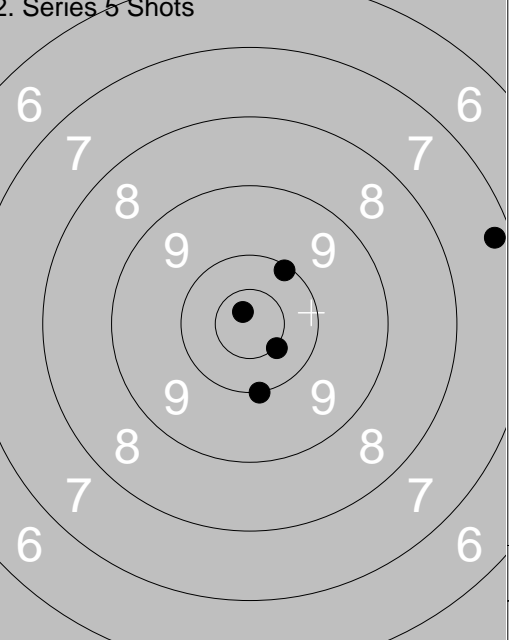
<p>1. Series 5 Shots</p> 	<p>1: *10.5 ↖ 2: 9.6 ← 3: *10.7 ↖ 4: 9.7 ↓ 5: *10.6 ↗</p>	<p>2. Series 5 Shots</p> 		<p>1: *10.8 ↖ 2: 10.1 ↗ 3: *10.5 ↖ 4: 10.0 ↓ 5: 7.3 →</p>								
<table border="1" style="width:100%; border-collapse: collapse;"> <tr><td>Series</td><td style="text-align: right;">48.0</td></tr> <tr><td>Total</td><td style="text-align: right;">189.0</td></tr> </table>		Series	48.0	Total	189.0			<table border="1" style="width:100%; border-collapse: collapse;"> <tr><td>Series</td><td style="text-align: right;">47.0</td></tr> <tr><td>Total</td><td style="text-align: right;">236.0</td></tr> </table>	Series	47.0	Total	236.0
Series	48.0											
Total	189.0											
Series	47.0											
Total	236.0											

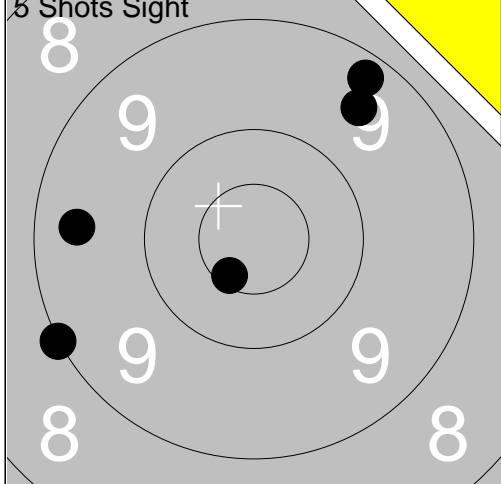

1:	9.5	↗
2:	9.4	←
3:	9.0	←
4:	9.2	↗
5:	*10.6	↘
Series		46.0
Total		0.0

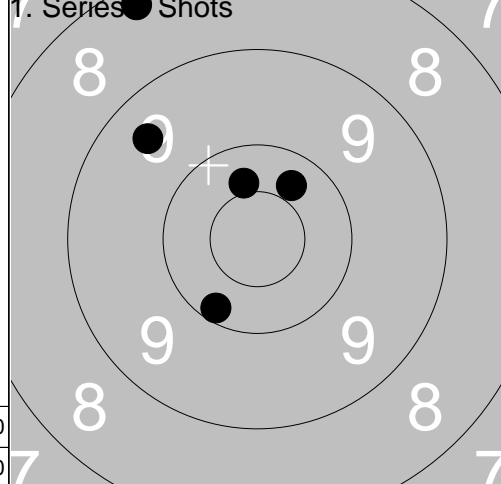

1:	10.2	↘
2:	10.3	↗
3:	8.3	↖
4:	9.5	↖
5:	10.4	↗
Series		47.0
Total		47.0

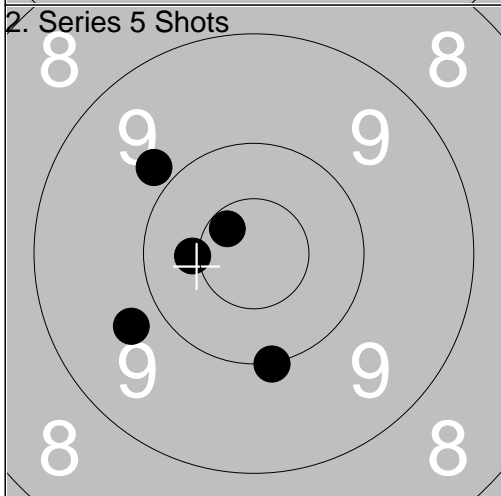

1:	*10.6	↖
2:	10.0	↘
3:	9.8	↗
4:	9.7	←
5:	*10.4	←
Series		48.0
Total		95.0

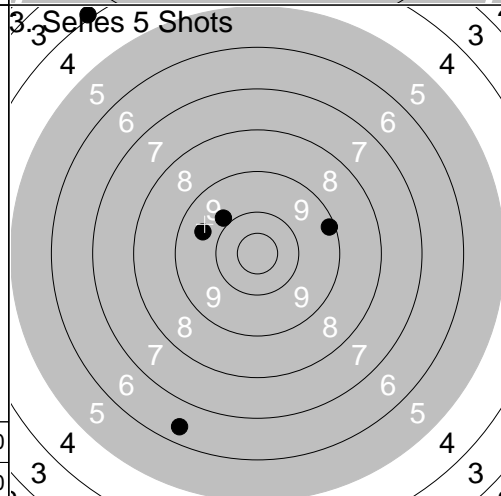

1:	9.2	→
2:	9.8	↗
3:	9.6	←
4:	3.9	↗
5:	6.4	↘
Series		36.0
Total		131.0

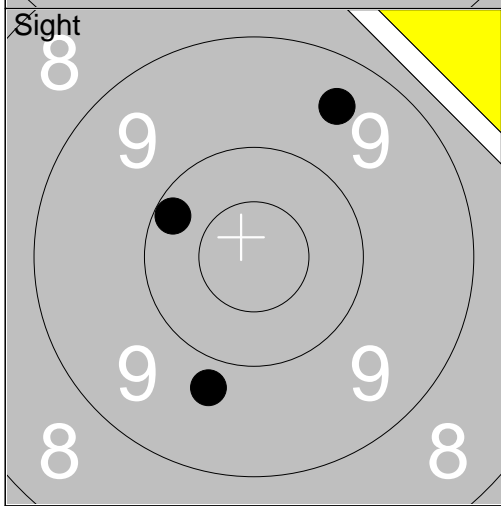

1:	9.5	↗
2:	9.8	↘
3:	10.2	↖
Series		28.0
Total		131.0

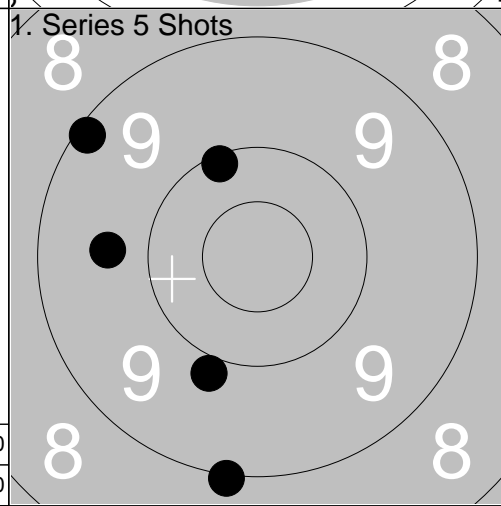

1:	9.0	↘
2:	9.7	←
3:	9.1	↗
4:	10.1	↗
5:	9.9	↘
Series		46.0
Total		177.0

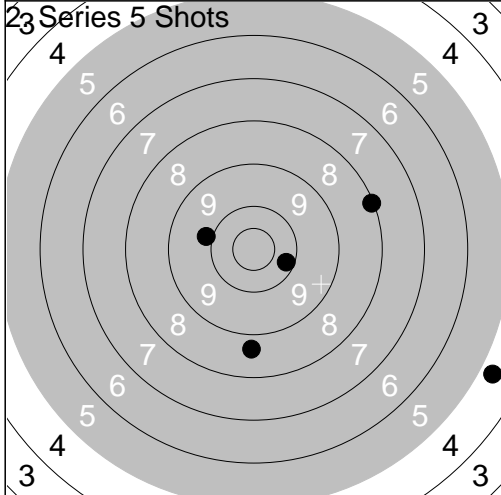

1:	9.9	←
2:	8.1	→
3:	10.2	→
4:	8.7	↘
5:	4.7	↘
Series		39.0
Total		216.0

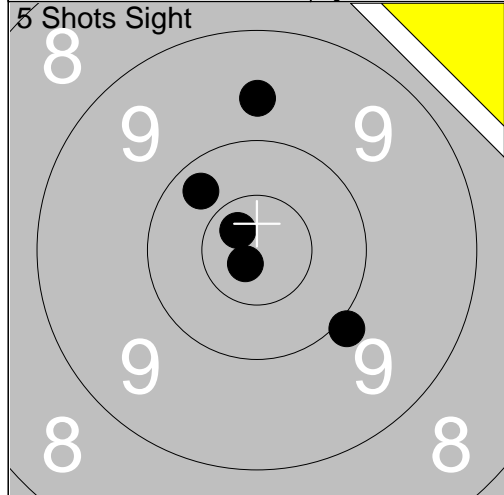

1:	*10.8	↙
2:	9.9	↘
3:	10.3	↗
4:	9.6	↑
5:	*10.7	↗
Series		48.0
Total		0.0

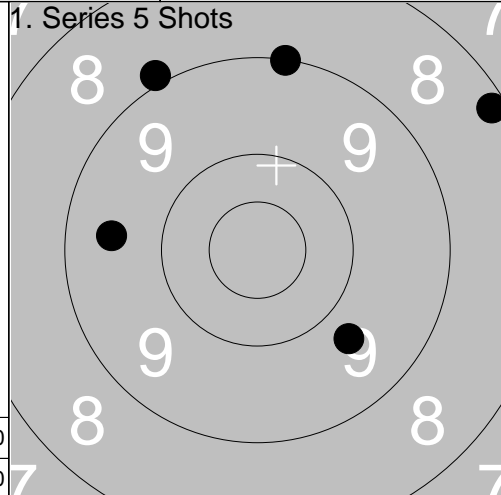

1:	8.2	↗
2:	9.7	↘
3:	9.0	↑
4:	8.9	↗
5:	9.5	←
Series		43.0
Total		43.0

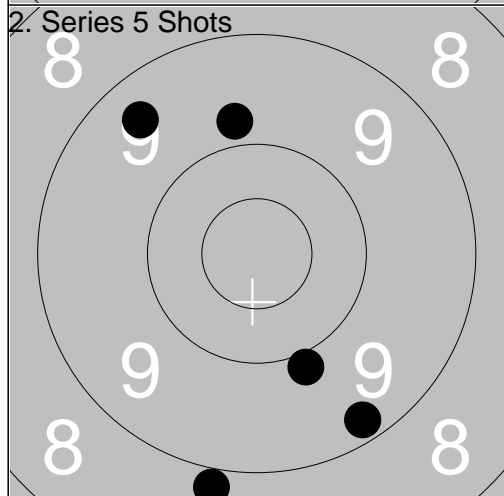

1:	9.4	↗
2:	9.8	↑
3:	8.9	↘
4:	9.9	↘
5:	9.2	↘
Series		44.0
Total		87.0

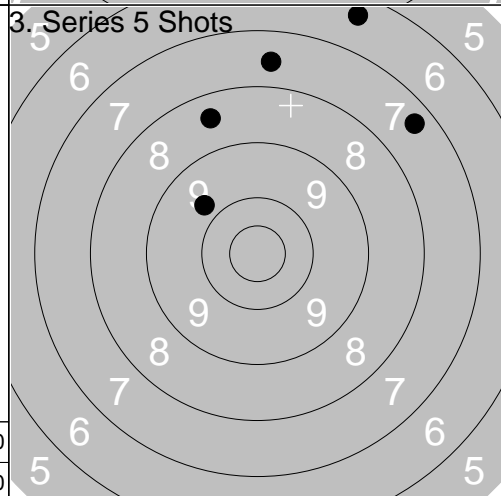

1:	9.7	↖
2:	7.4	↗
3:	7.6	↑
4:	8.5	↖
5:	6.4	↗
Series		37.0
Total		124.0

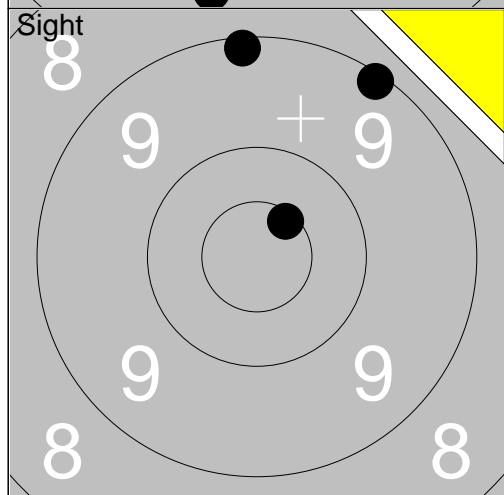

1:	9.1	↑
2:	*10.6	↗
3:	9.1	↗
Series		28.0
Total		124.0

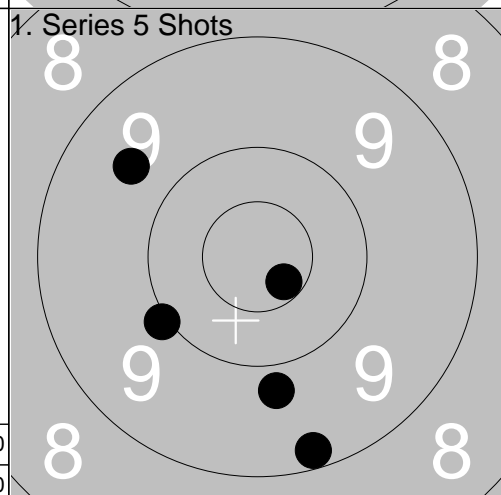

1:	9.8	↓
2:	9.6	↖
3:	10.0	↖
4:	9.2	↘
5:	*10.6	↘
Series		47.0
Total		171.0

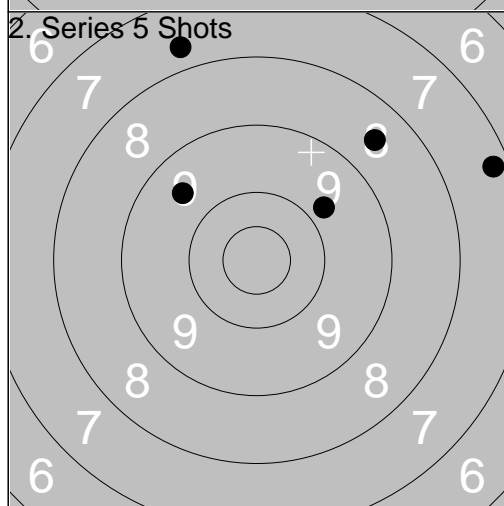

1:	7.3	→
2:	9.6	↖
3:	9.8	↗
4:	8.5	↗
5:	7.7	↑
Series		40.0
Total		211.0

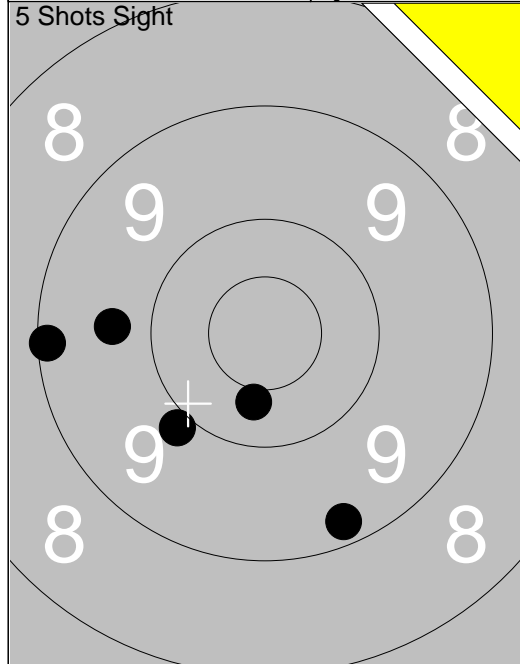

1: 9.1 ←	
2: 9.7 ←	
3: 10.4 ↓	
4: 9.9 ↙	
5: 9.2 ↓	
Series 46.0	
Total 0.0	

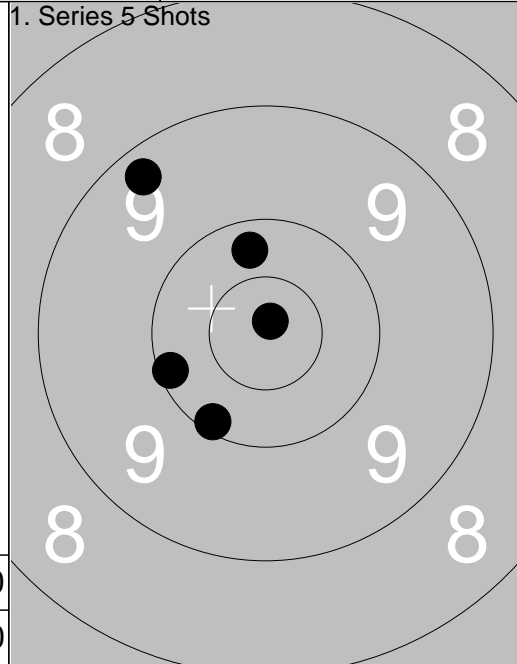

1: 10.1 ↖	
2: 10.3 ↑	
3: 10.1 ↙	
4: *10.8 ↗	
5: 9.3 ↖	
Series 49.0	
Total 49.0	

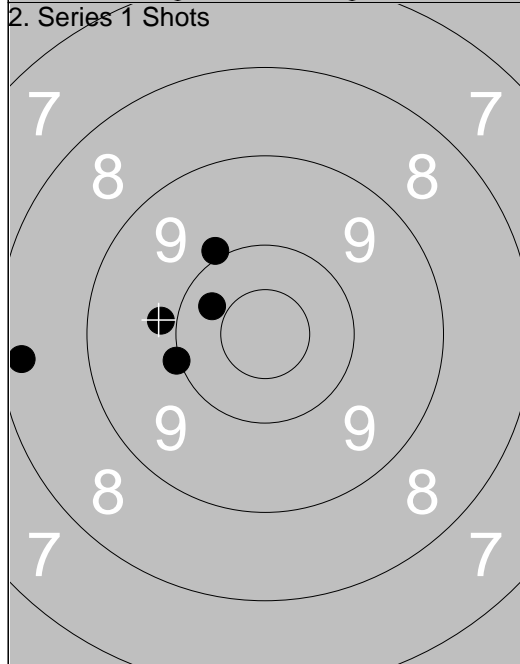

1: 9.9 ↖	
2: 10.0 ←	
3: 10.3 ↖	
4: 9.9 ←	
5: 8.3 ←	
Series 46.0	
Total 95.0	

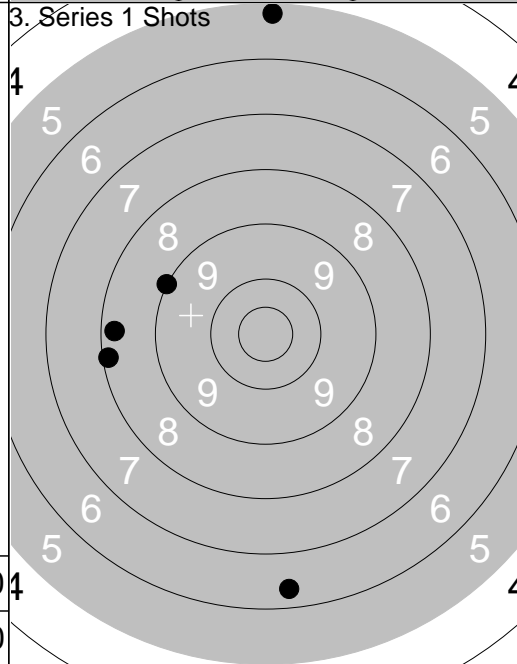

6: 9.0 ↖	
7: 8.1 ←	
8: 8.3 ←	
9: 5.2 ↑	
10: 6.4 ↓	
Series 36.0	
Total 131.0	

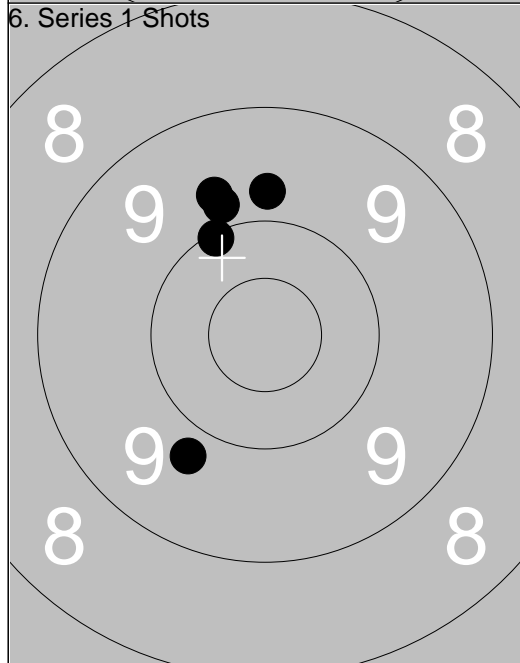

11: 9.8 ↑	
12: 9.8 ↙	
13: 9.7 ↑	
14: 9.8 ↑	
15: 10.1 ↖	
Series 46.0	
Total 177.0	

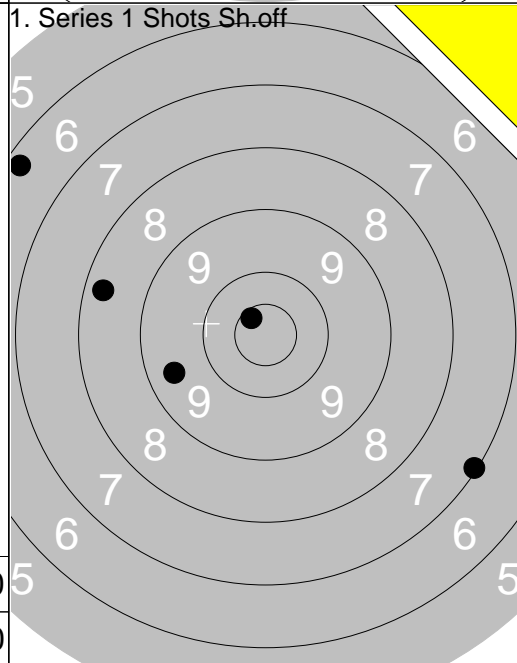

1: 8.3 ←	
2: *10.6 ↖	
3: 9.4 ←	
4: 7.1 ↘	
5: 6.3 ↖	
Series 40.0	
Total 177.0	

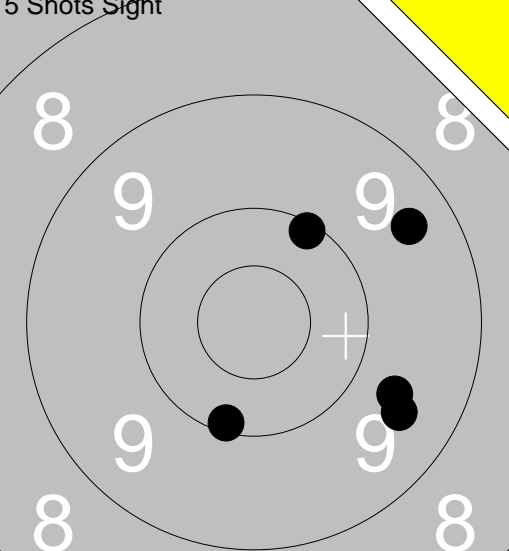
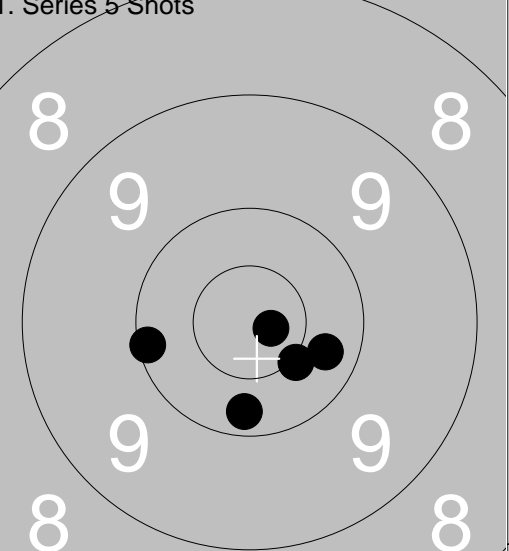
<p>5 Shots Sight</p>  <table border="1" style="width:100%; border-collapse: collapse;"> <tr><td>1:</td><td>9.5</td><td>↘</td></tr> <tr><td>2:</td><td>10.1</td><td>↗</td></tr> <tr><td>3:</td><td>10.1</td><td>↓</td></tr> <tr><td>4:</td><td>9.6</td><td>↘</td></tr> <tr><td>5:</td><td>9.4</td><td>↗</td></tr> </table> <table border="1" style="width:100%; border-collapse: collapse;"> <tr><td>Series</td><td>47.0</td></tr> <tr><td>Total</td><td>0.0</td></tr> </table>	1:	9.5	↘	2:	10.1	↗	3:	10.1	↓	4:	9.6	↘	5:	9.4	↗	Series	47.0	Total	0.0	<p>1. Series 5 Shots</p>  <table border="1" style="width:100%; border-collapse: collapse;"> <tr><td>1:</td><td>10.3</td><td>↘</td></tr> <tr><td>2:</td><td>*10.5</td><td>↘</td></tr> <tr><td>3:</td><td>10.1</td><td>←</td></tr> <tr><td>4:</td><td>*10.8</td><td>↘</td></tr> <tr><td>5:</td><td>10.2</td><td>↓</td></tr> </table> <table border="1" style="width:100%; border-collapse: collapse;"> <tr><td>Series</td><td>50.0</td></tr> <tr><td>Total</td><td>50.0</td></tr> </table>	1:	10.3	↘	2:	*10.5	↘	3:	10.1	←	4:	*10.8	↘	5:	10.2	↓	Series	50.0	Total	50.0	
1:	9.5	↘																																						
2:	10.1	↗																																						
3:	10.1	↓																																						
4:	9.6	↘																																						
5:	9.4	↗																																						
Series	47.0																																							
Total	0.0																																							
1:	10.3	↘																																						
2:	*10.5	↘																																						
3:	10.1	←																																						
4:	*10.8	↘																																						
5:	10.2	↓																																						
Series	50.0																																							
Total	50.0																																							

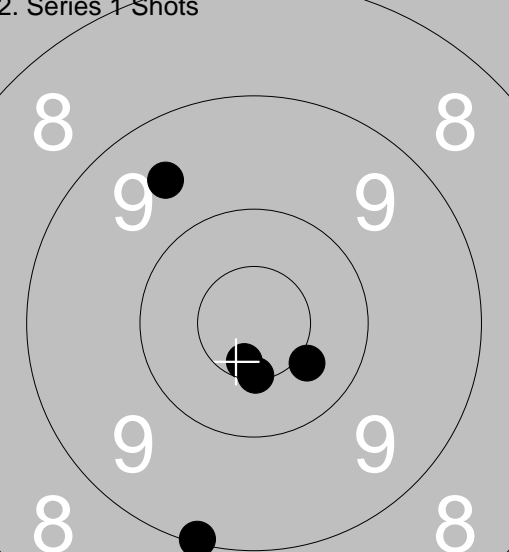
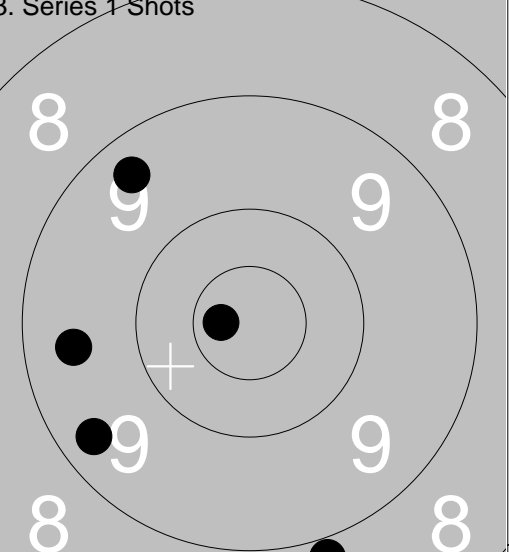
<p>2. Series 1 Shots</p>  <table border="1" style="width:100%; border-collapse: collapse;"> <tr><td>1:</td><td>*10.6</td><td>↓</td></tr> <tr><td>2:</td><td>9.1</td><td>↓</td></tr> <tr><td>3:</td><td>*10.5</td><td>↓</td></tr> <tr><td>4:</td><td>10.4</td><td>↘</td></tr> <tr><td>5:</td><td>9.6</td><td>↗</td></tr> </table> <table border="1" style="width:100%; border-collapse: collapse;"> <tr><td>Series</td><td>48.0</td></tr> <tr><td>Total</td><td>98.0</td></tr> </table>	1:	*10.6	↓	2:	9.1	↓	3:	*10.5	↓	4:	10.4	↘	5:	9.6	↗	Series	48.0	Total	98.0	<p>3. Series 1 Shots</p>  <table border="1" style="width:100%; border-collapse: collapse;"> <tr><td>6:</td><td>*10.7</td><td>←</td></tr> <tr><td>7:</td><td>8.9</td><td>↓</td></tr> <tr><td>8:</td><td>9.4</td><td>↗</td></tr> <tr><td>9:</td><td>9.3</td><td>↙</td></tr> <tr><td>10:</td><td>9.5</td><td>←</td></tr> </table> <table border="1" style="width:100%; border-collapse: collapse;"> <tr><td>Series</td><td>45.0</td></tr> <tr><td>Total</td><td>143.0</td></tr> </table>	6:	*10.7	←	7:	8.9	↓	8:	9.4	↗	9:	9.3	↙	10:	9.5	←	Series	45.0	Total	143.0	
1:	*10.6	↓																																						
2:	9.1	↓																																						
3:	*10.5	↓																																						
4:	10.4	↘																																						
5:	9.6	↗																																						
Series	48.0																																							
Total	98.0																																							
6:	*10.7	←																																						
7:	8.9	↓																																						
8:	9.4	↗																																						
9:	9.3	↙																																						
10:	9.5	←																																						
Series	45.0																																							
Total	143.0																																							

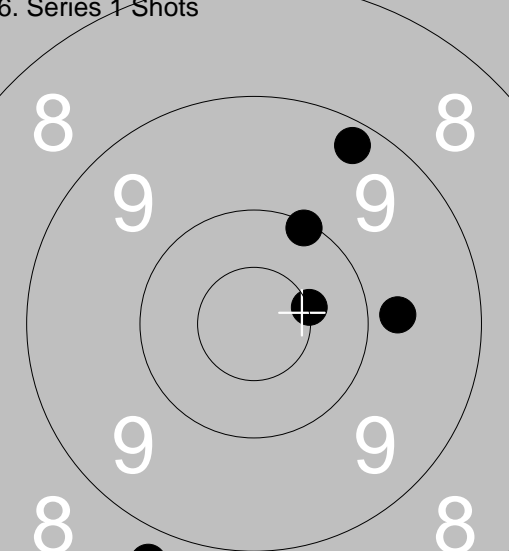
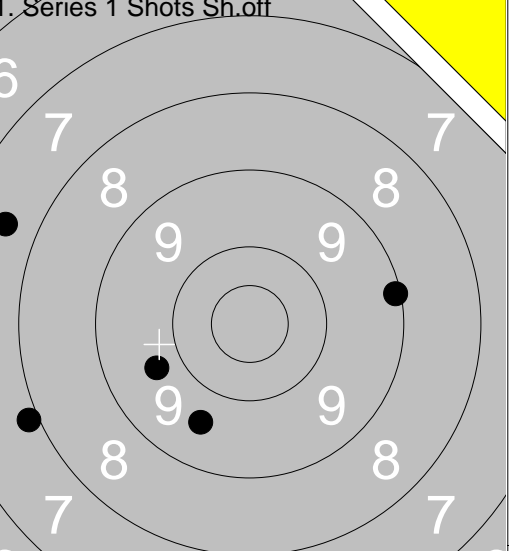
<p>6. Series 1 Shots</p>  <table border="1" style="width:100%; border-collapse: collapse;"> <tr><td>11:</td><td>8.7</td><td>↓</td></tr> <tr><td>12:</td><td>9.8</td><td>→</td></tr> <tr><td>13:</td><td>9.2</td><td>↗</td></tr> <tr><td>14:</td><td>10.1</td><td>↗</td></tr> <tr><td>15:</td><td>*10.5</td><td>↘</td></tr> </table> <table border="1" style="width:100%; border-collapse: collapse;"> <tr><td>Series</td><td>46.0</td></tr> <tr><td>Total</td><td>189.0</td></tr> </table>	11:	8.7	↓	12:	9.8	→	13:	9.2	↗	14:	10.1	↗	15:	*10.5	↘	Series	46.0	Total	189.0	<p>1. Series 1 Shots Sh.off</p>  <table border="1" style="width:100%; border-collapse: collapse;"> <tr><td>1:</td><td>9.6</td><td>↓</td></tr> <tr><td>2:</td><td>9.1</td><td>→</td></tr> <tr><td>3:</td><td>9.7</td><td>←</td></tr> <tr><td>4:</td><td>7.6</td><td>←</td></tr> <tr><td>5:</td><td>7.9</td><td>←</td></tr> </table> <table border="1" style="width:100%; border-collapse: collapse;"> <tr><td>Series</td><td>41.0</td></tr> <tr><td>Total</td><td>189.0</td></tr> </table>	1:	9.6	↓	2:	9.1	→	3:	9.7	←	4:	7.6	←	5:	7.9	←	Series	41.0	Total	189.0	
11:	8.7	↓																																						
12:	9.8	→																																						
13:	9.2	↗																																						
14:	10.1	↗																																						
15:	*10.5	↘																																						
Series	46.0																																							
Total	189.0																																							
1:	9.6	↓																																						
2:	9.1	→																																						
3:	9.7	←																																						
4:	7.6	←																																						
5:	7.9	←																																						
Series	41.0																																							
Total	189.0																																							

<p>5 Shots Sight</p>	1: 8.4 ← 2: 10.3 ← 3: 9.8 ↑ 4: *10.5 ↑ 5: 9.6 ←	<p>1. Series 5 Shots</p>	1: 9.8 ↓ 2: *10.5 ← 3: 7.9 ← 4: 10.4 ↓ 5: 9.9 ↑
Series 46.0		Series 45.0	
Total 0.0		Total 45.0	

<p>2. Series 5 Shots</p>	1: 9.5 ← 2: 9.5 ↓ 3: 9.6 ↓ 4: 9.8 ← 5: 10.1 ←	<p>3. Series 5 Shots</p>	1: 8.3 ↑ 2: 9.5 ↑ 3: 8.5 ↓ 4: 6.0 ↓ 5: 4.5 ↓
Series 46.0		Series 35.0	
Total 91.0		Total 126.0	

<p>Sight</p>	1: 9.2 ↓ 2: 9.5 ← 3: 10.3 ↓	<p>1. Series 5 Shots</p>	1: 9.8 → 2: 8.7 ↓ 3: 10.4 → 4: *10.7 ← 5: 9.6 ←
Series 28.0		Series 46.0	
Total 126.0		Total 172.0	

<p>2. Series 5 Shots</p>	1: 9.5 → 2: 9.1 ↓ 3: 9.4 ↓ 4: 8.1 ← 5: 4.7 ←		
Series 39.0			
Total 211.0			

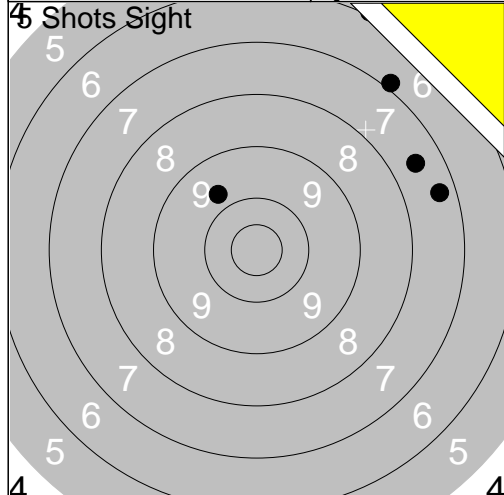

1:	7.3	→
2:	6.9	↗
3:	9.7	↖
4:	7.5	→
5:	6.0	↗

Series	35.0
Total	0.0

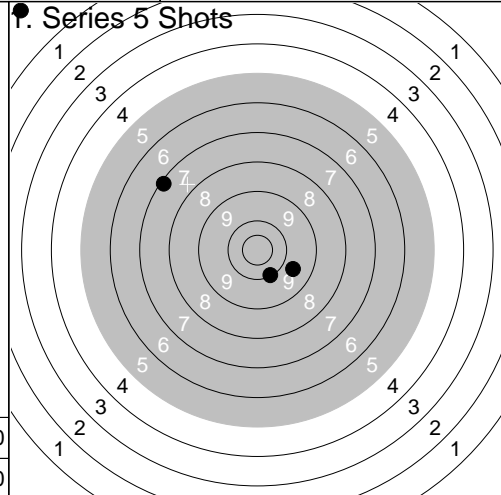

1:	7.1	↖
2:	0.0	↗
3:	9.7	↘
4:	10.1	↘
5:	0.0	

Series	26.0
Total	26.0

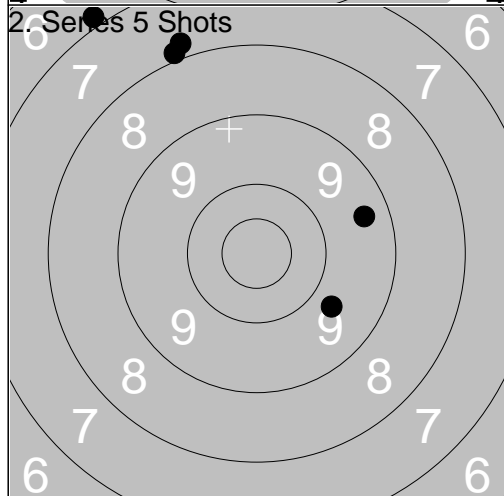

1:	6.9	↗
2:	7.9	↗
3:	9.4	→
4:	7.8	↗
5:	9.7	↘

Series	38.0
Total	64.0

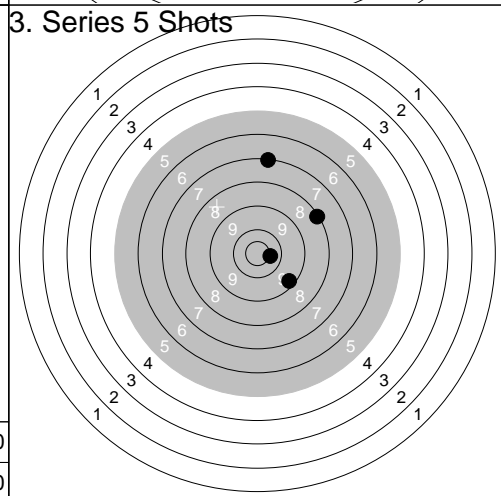

1:	7.1	↑
2:	0.0	↖
3:	8.1	↗
4:	*10.5	→
5:	9.3	↘

Series	34.0
Total	98.0

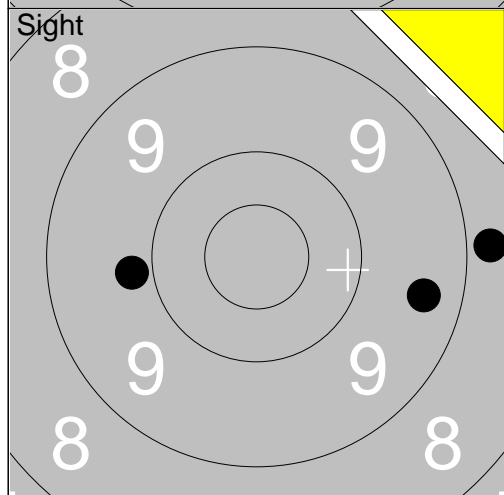

1:	9.8	←
2:	8.8	→
3:	9.4	→

Series	26.0
Total	98.0

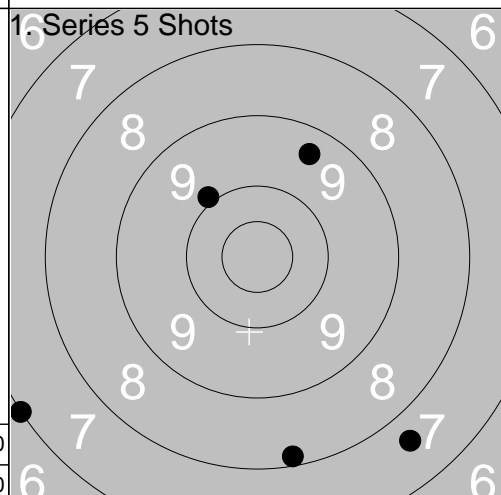

1:	9.9	↖
2:	7.0	↖
3:	8.2	↘
4:	9.4	↗
5:	7.6	↘

Series	40.0
Total	138.0

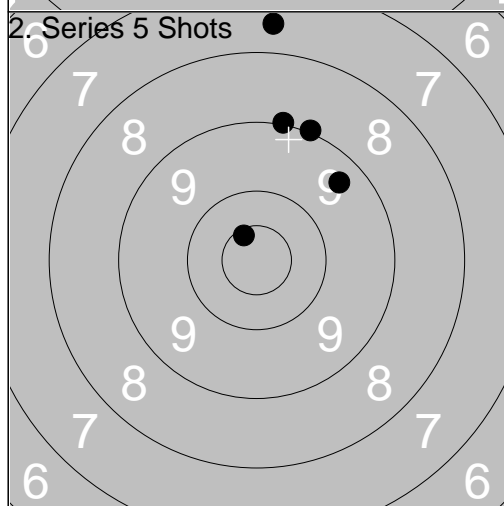

1:	9.4	↗
2:	9.0	↗
3:	7.6	↑
4:	9.0	↑
5:	*10.6	↖

Series	44.0
Total	182.0

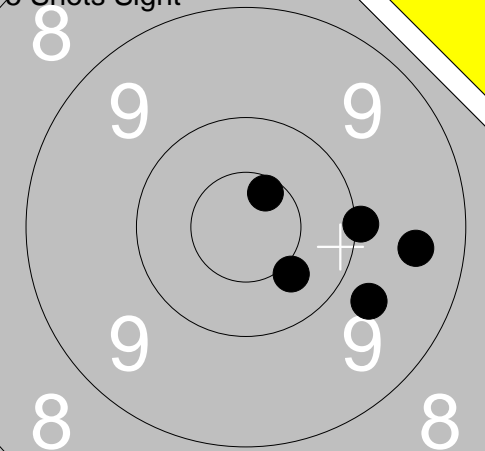
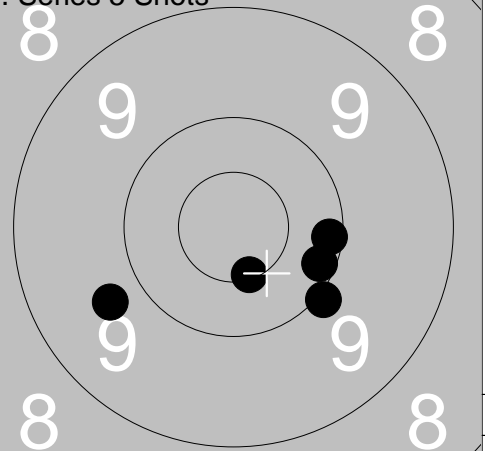
<p>5 Shots Sight</p>  <p style="text-align: right;">Series 48.0 Total 0.0</p>	<p>1: 9.5 →</p> <p>2: *10.6 ↗</p> <p>3: 9.7 ↘</p> <p>4: 10.4 ↘</p> <p>5: 10.0 →</p>	<p>1. Series 5 Shots</p>  <p style="text-align: right;">Series 49.0 Total 49.0</p>	<p>1: 10.2 ↗</p> <p>2: *10.5 ↓</p> <p>3: 9.7 ↖</p> <p>4: 10.1 →</p> <p>5: 10.0 ↘</p>
---	---	--	--

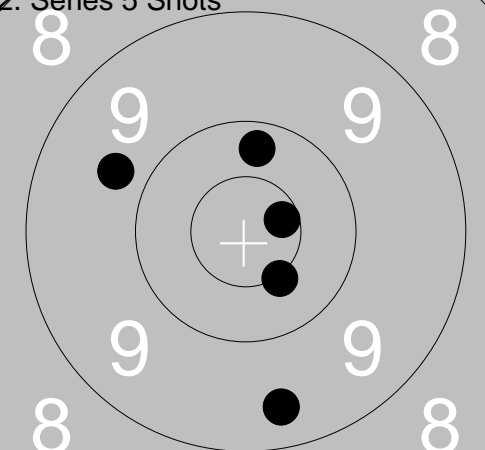
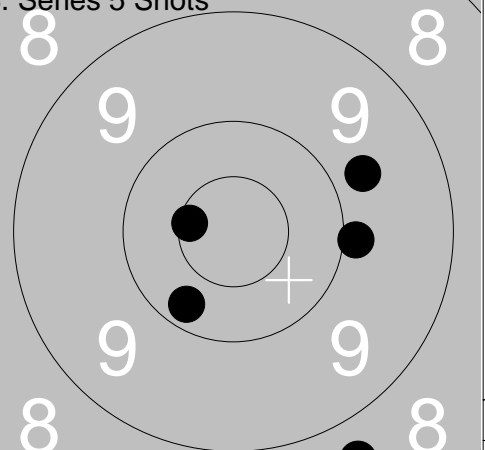
<p>2. Series 5 Shots</p>  <p style="text-align: right;">Series 48.0 Total 97.0</p>	<p>1: *10.5 ↓</p> <p>2: 9.4 ↓</p> <p>3: 10.2 ↑</p> <p>4: *10.6 →</p> <p>5: 9.7 ↖</p>	<p>3. Series 5 Shots</p>  <p style="text-align: right;">Series 46.0 Total 143.0</p>	<p>1: 9.7 ↗</p> <p>2: 9.9 →</p> <p>3: 8.7 ↓</p> <p>4: *10.6 ↖</p> <p>5: 10.2 ↘</p>
---	--	--	--

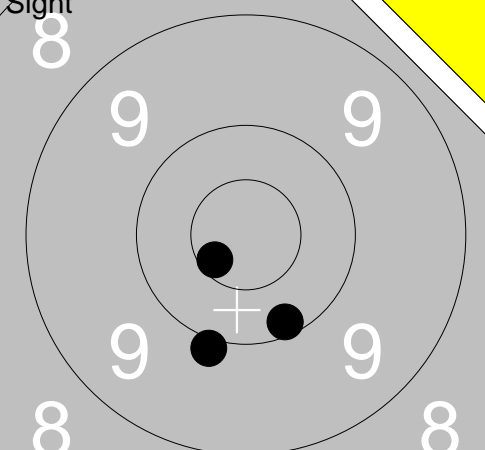
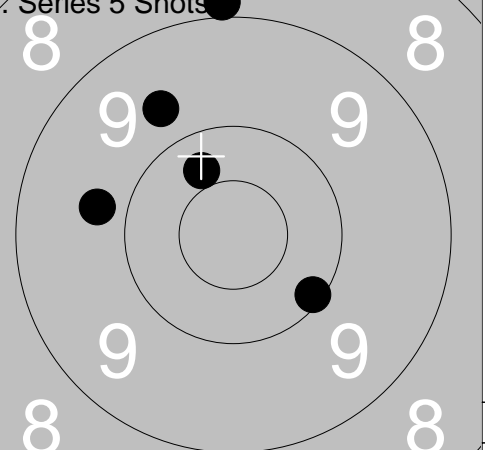
<p>Sight</p>  <p style="text-align: right;">Series 29.0 Total 143.0</p>	<p>1: 10.1 ↓</p> <p>2: *10.6 ↖</p> <p>3: 9.9 ↓</p>	<p>1. Series 5 Shots</p>  <p style="text-align: right;">Series 46.0 Total 189.0</p>	<p>1: 10.1 ↘</p> <p>2: 10.3 ↗</p> <p>3: 9.7 ↖</p> <p>4: 8.9 ↑</p> <p>5: 9.7 ↗</p>
---	--	---	---

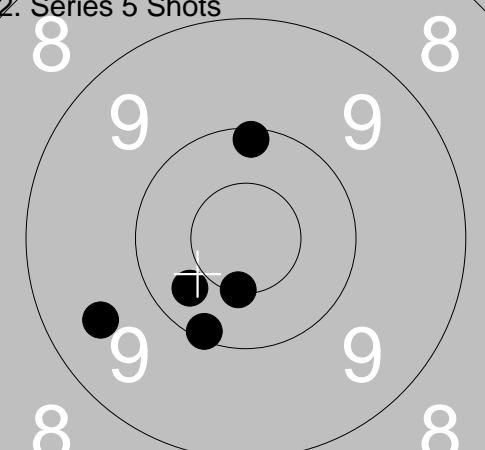
<p>2. Series 5 Shots</p>  <p style="text-align: right;">Series 49.0 Total 238.0</p>	<p>1: *10.5 ↓</p> <p>2: 10.1 ↑</p> <p>3: 10.1 ↓</p> <p>4: 10.3 ↖</p> <p>5: 9.5 ↖</p>		
---	--	--	--

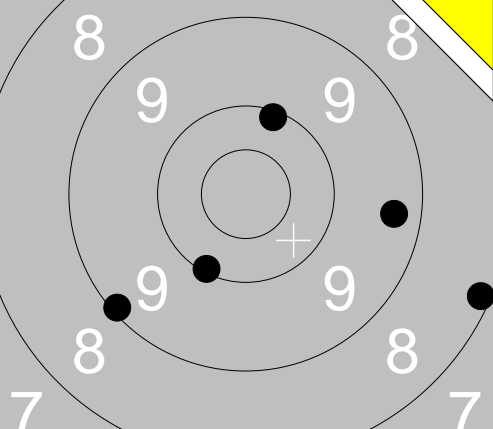
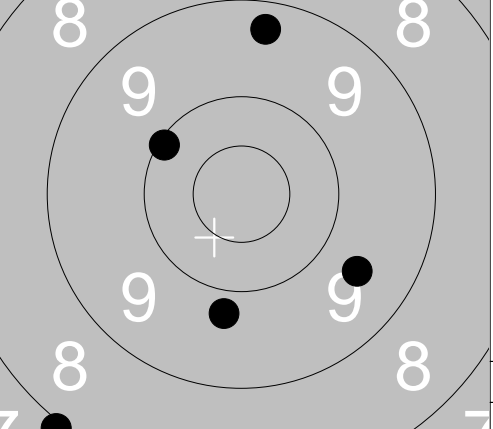
<p>5 Shots Sight</p> 	<p>1: 9.1 ↙ 2: 8.1 → 3: 10.1 ↘ 4: 10.1 ↑ 5: 9.3 →</p>	<p>1. Series 5 Shots</p> 	<p>1: 9.3 ↑ 2: 10.1 ↙ 3: 9.8 ↘ 4: 9.6 → 5: 8.0 ↘</p>
Series	46.0	Series	45.0
Total	0.0	Total	45.0

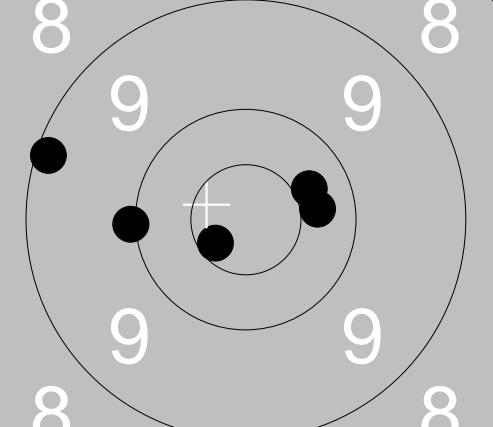
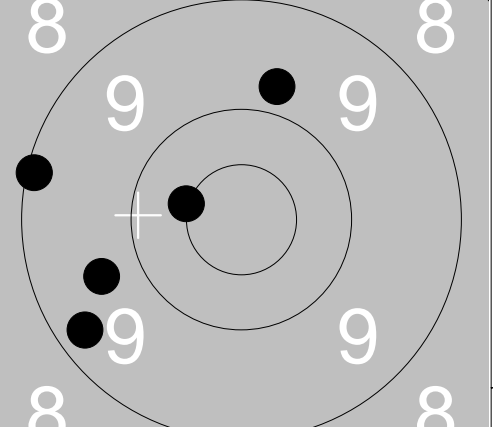
<p>2. Series 5 Shots</p> 	<p>1: 10.4 ↗ 2: 10.3 → 3: *10.6 ↙ 4: 10.0 ← 5: 9.1 ←</p>	<p>3. Series 5 Shots</p> 	<p>1: 9.3 ↙ 2: 9.1 ← 3: 9.8 ↑ 4: 9.7 ← 5: *10.5 ←</p>
Series	49.0	Series	46.0
Total	94.0	Total	140.0

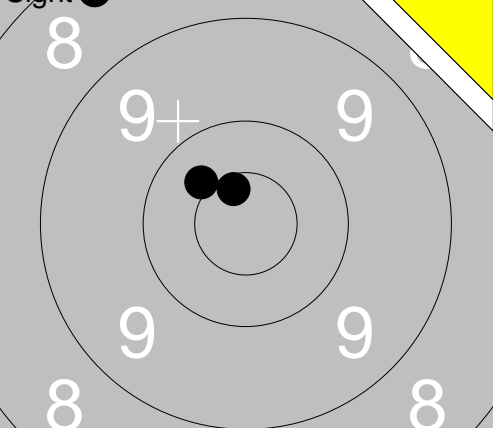
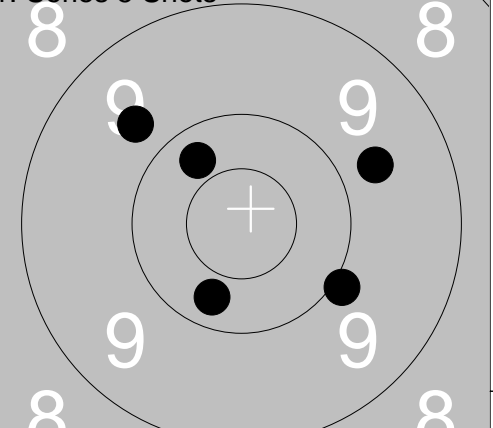
<p>Sight</p> 	<p>1: 10.4 ↗ 2: 8.3 ↗ 3: *10.6 ↗</p>	<p>1. Series 5 Shots</p> 	<p>1: 9.7 ↗ 2: 10.3 ↗ 3: 10.3 ↘ 4: 9.7 ↗ 5: 9.9 ↘</p>
Series	28.0	Series	47.0
Total	140.0	Total	187.0

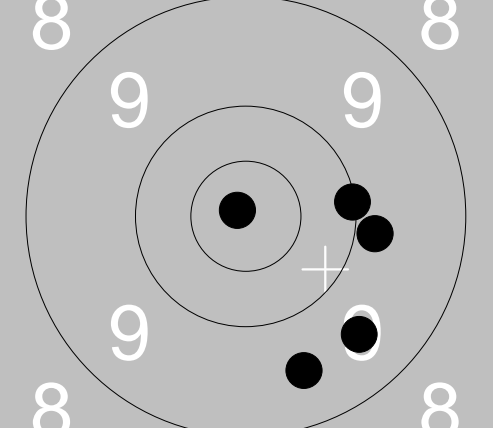
<p>2. Series 5 Shots</p> 	<p>1: 9.5 ↘ 2: *10.9 ↗ 3: 9.5 ↘ 4: 9.8 → 5: 10.0 →</p>		
Series	47.0		
Total	234.0		

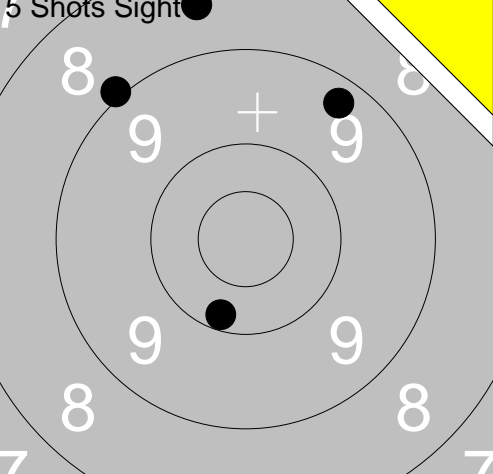
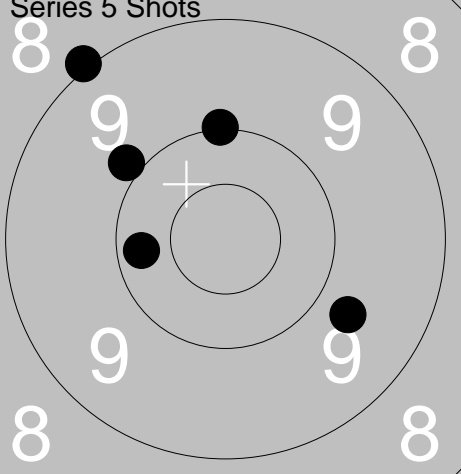
5 Shots Sight 	1: 8.5 ↑ 2: 9.3 ↗ 3: 8.3 ↗ 4: 10.2 ↓ 5: 9.0 ↖	1. Series 5 Shots 	1: 10.2 ← 2: 9.0 ↗ 3: 9.7 ↘ 4: 9.9 ↗ 5: 10.0 ↑
Series 44.0 Total 0.0		Series 47.0 Total 47.0	

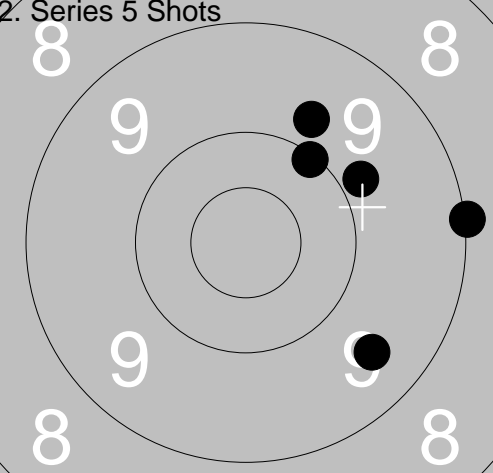
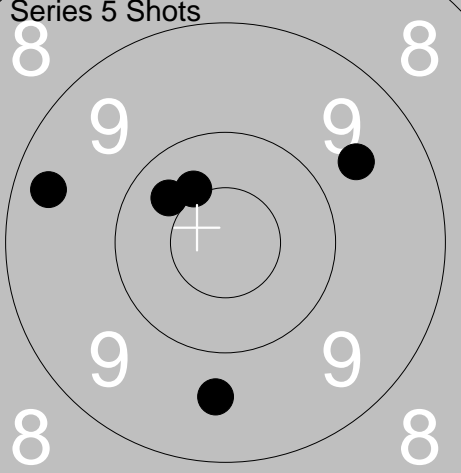
2. Series 5 Shots 	1: 10.1 ↗ 2: 9.0 → 3: 9.8 ↗ 4: 9.5 ↓ 5: 9.8 ↗	3. Series 5 Shots 	1: 9.4 ← 2: 9.6 ↗ 3: 10.3 ↖ 4: 9.6 ↓ 5: *10.4 ↗
Series 46.0 Total 93.0		Series 47.0 Total 140.0	

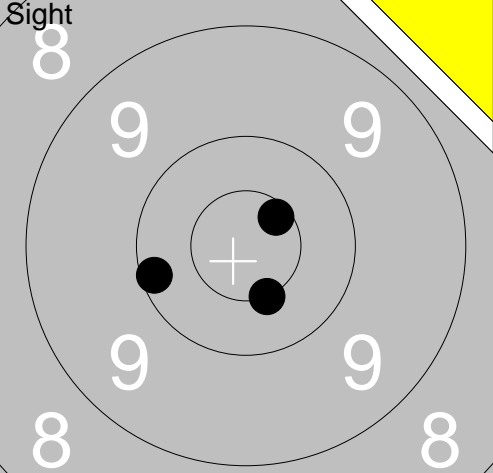
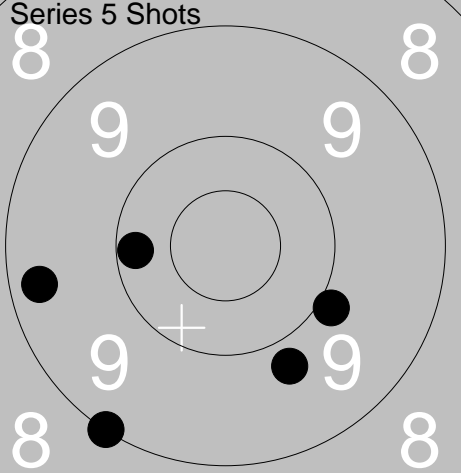
Sight 	1: 10.1 ← 2: *10.5 ↓ 3: *10.6 ↗	1. Series 5 Shots 	1: 9.9 ↘ 2: 9.0 ↓ 3: 9.3 ← 4: 10.2 ← 5: 9.8 ↓
Series 30.0 Total 140.0		Series 46.0 Total 186.0	

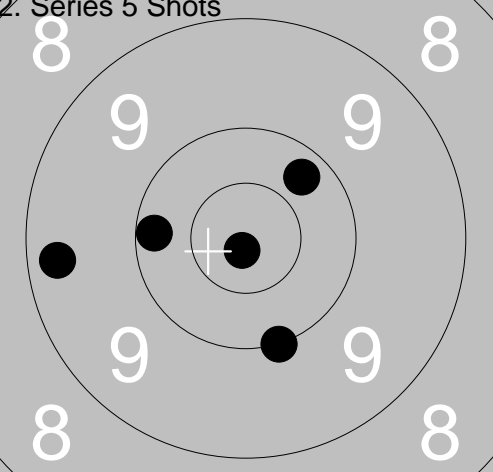
2. Series 5 Shots 	1: 10.2 ↗ 2: 9.3 ← 3: *10.8 ↓ 4: 10.2 ← 5: 10.0 ↓		
Series 49.0 Total 235.0			

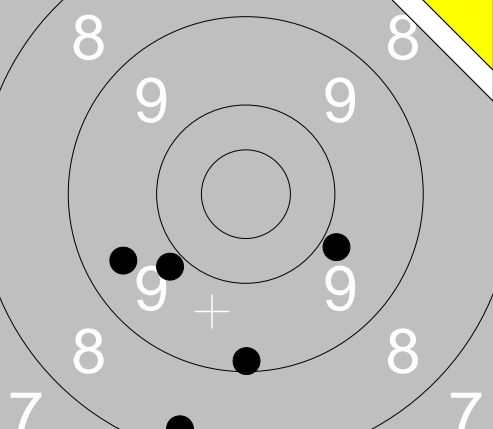
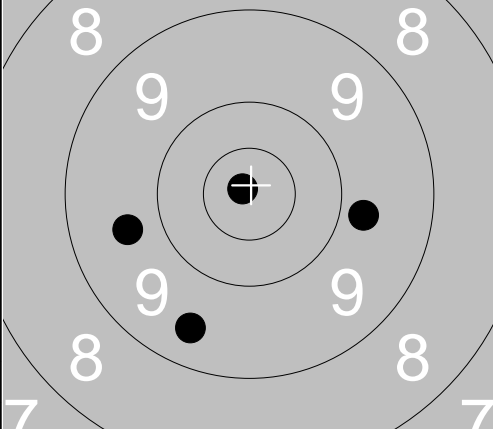
5 Shots Sight 	<table border="1" style="width:100%; border-collapse: collapse;"> <tr><td>1:</td><td>8.3</td><td>↓</td></tr> <tr><td>2:</td><td>9.2</td><td>↓</td></tr> <tr><td>3:</td><td>9.8</td><td>→</td></tr> <tr><td>4:</td><td>9.5</td><td>←</td></tr> <tr><td>5:</td><td>9.9</td><td>↙</td></tr> <tr><td colspan="2">Series</td><td>44.0</td></tr> <tr><td colspan="2">Total</td><td>0.0</td></tr> </table>	1:	8.3	↓	2:	9.2	↓	3:	9.8	→	4:	9.5	←	5:	9.9	↙	Series		44.0	Total		0.0	1. Series 5 Shots  <table border="1" style="width:100%; border-collapse: collapse;"> <tr><td>1:</td><td>8.3</td><td>↗</td></tr> <tr><td>2:</td><td>9.4</td><td>↓</td></tr> <tr><td>3:</td><td>9.8</td><td>→</td></tr> <tr><td>4:</td><td>9.7</td><td>←</td></tr> <tr><td>5:</td><td>*10.9</td><td>↙</td></tr> <tr><td colspan="2">Series</td><td>45.0</td></tr> <tr><td colspan="2">Total</td><td>45.0</td></tr> </table>	1:	8.3	↗	2:	9.4	↓	3:	9.8	→	4:	9.7	←	5:	*10.9	↙	Series		45.0	Total		45.0
1:	8.3	↓																																										
2:	9.2	↓																																										
3:	9.8	→																																										
4:	9.5	←																																										
5:	9.9	↙																																										
Series		44.0																																										
Total		0.0																																										
1:	8.3	↗																																										
2:	9.4	↓																																										
3:	9.8	→																																										
4:	9.7	←																																										
5:	*10.9	↙																																										
Series		45.0																																										
Total		45.0																																										

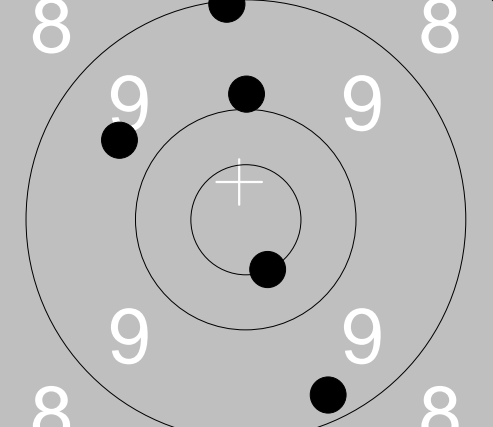
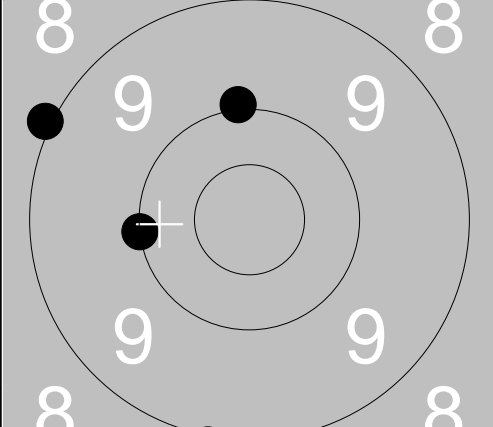
2. Series 5 Shots  <table border="1" style="width:100%; border-collapse: collapse;"> <tr><td>1:</td><td>9.9</td><td>↑</td></tr> <tr><td>2:</td><td>9.1</td><td>↑</td></tr> <tr><td>3:</td><td>*10.5</td><td>↓</td></tr> <tr><td>4:</td><td>9.7</td><td>↗</td></tr> <tr><td>5:</td><td>9.3</td><td>↓</td></tr> <tr><td colspan="2">Series</td><td>46.0</td></tr> <tr><td colspan="2">Total</td><td>91.0</td></tr> </table>	1:	9.9	↑	2:	9.1	↑	3:	*10.5	↓	4:	9.7	↗	5:	9.3	↓	Series		46.0	Total		91.0	3. Series 5 Shots  <table border="1" style="width:100%; border-collapse: collapse;"> <tr><td>1:</td><td>10.0</td><td>←</td></tr> <tr><td>2:</td><td>9.0</td><td>↓</td></tr> <tr><td>3:</td><td>9.0</td><td>↖</td></tr> <tr><td>4:</td><td>10.0</td><td>↑</td></tr> <tr><td>5:</td><td>0.0</td><td></td></tr> <tr><td colspan="2">Series</td><td>38.0</td></tr> <tr><td colspan="2">Total</td><td>129.0</td></tr> </table>	1:	10.0	←	2:	9.0	↓	3:	9.0	↖	4:	10.0	↑	5:	0.0		Series		38.0	Total		129.0
1:	9.9	↑																																									
2:	9.1	↑																																									
3:	*10.5	↓																																									
4:	9.7	↗																																									
5:	9.3	↓																																									
Series		46.0																																									
Total		91.0																																									
1:	10.0	←																																									
2:	9.0	↓																																									
3:	9.0	↖																																									
4:	10.0	↑																																									
5:	0.0																																										
Series		38.0																																									
Total		129.0																																									

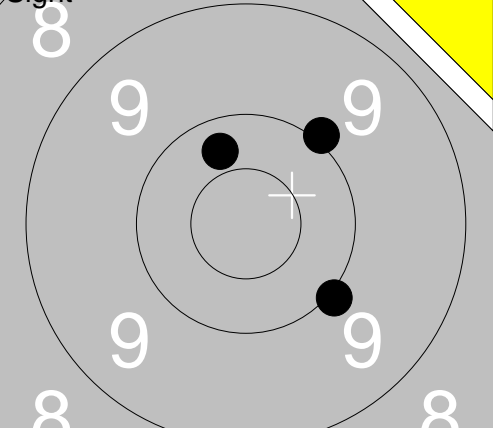
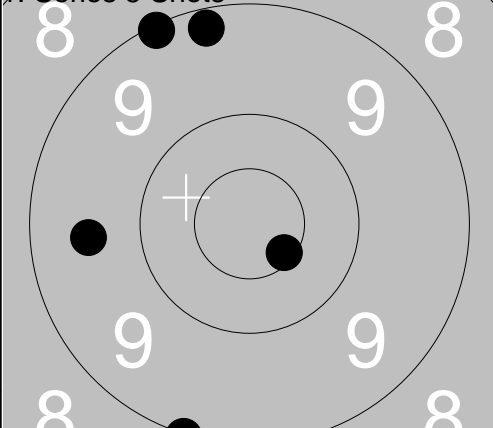
Sight  <table border="1" style="width:100%; border-collapse: collapse;"> <tr><td>1:</td><td>10.0</td><td>↘</td></tr> <tr><td>2:</td><td>10.3</td><td>↑</td></tr> <tr><td>3:</td><td>10.0</td><td>↗</td></tr> <tr><td colspan="2">Series</td><td>30.0</td></tr> <tr><td colspan="2">Total</td><td>129.0</td></tr> </table>	1:	10.0	↘	2:	10.3	↑	3:	10.0	↗	Series		30.0	Total		129.0	1. Series 5 Shots  <table border="1" style="width:100%; border-collapse: collapse;"> <tr><td>1:</td><td>9.6</td><td>←</td></tr> <tr><td>2:</td><td>*10.6</td><td>↘</td></tr> <tr><td>3:</td><td>9.1</td><td>↗</td></tr> <tr><td>4:</td><td>9.2</td><td>↑</td></tr> <tr><td>5:</td><td>9.0</td><td>↓</td></tr> <tr><td colspan="2">Series</td><td>46.0</td></tr> <tr><td colspan="2">Total</td><td>175.0</td></tr> </table>	1:	9.6	←	2:	*10.6	↘	3:	9.1	↗	4:	9.2	↑	5:	9.0	↓	Series		46.0	Total		175.0
1:	10.0	↘																																			
2:	10.3	↑																																			
3:	10.0	↗																																			
Series		30.0																																			
Total		129.0																																			
1:	9.6	←																																			
2:	*10.6	↘																																			
3:	9.1	↗																																			
4:	9.2	↑																																			
5:	9.0	↓																																			
Series		46.0																																			
Total		175.0																																			

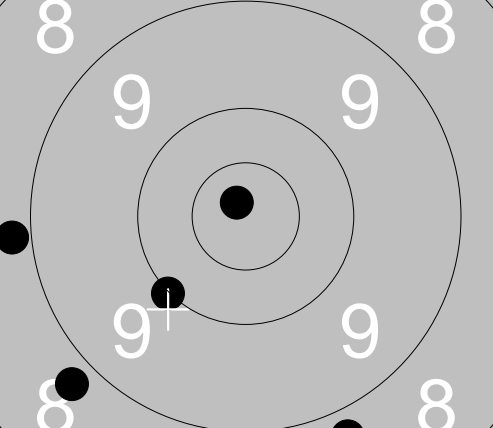
2. Series 5 Shots  <table border="1" style="width:100%; border-collapse: collapse;"> <tr><td>1:</td><td>8.9</td><td>←</td></tr> <tr><td>2:</td><td>8.8</td><td>↙</td></tr> <tr><td>3:</td><td>10.0</td><td>↙</td></tr> <tr><td>4:</td><td>8.8</td><td>↓</td></tr> <tr><td>5:</td><td>*10.8</td><td>↗</td></tr> <tr><td colspan="2">Series</td><td>44.0</td></tr> <tr><td colspan="2">Total</td><td>219.0</td></tr> </table>	1:	8.9	←	2:	8.8	↙	3:	10.0	↙	4:	8.8	↓	5:	*10.8	↗	Series		44.0	Total		219.0		
1:	8.9	←																					
2:	8.8	↙																					
3:	10.0	↙																					
4:	8.8	↓																					
5:	*10.8	↗																					
Series		44.0																					
Total		219.0																					

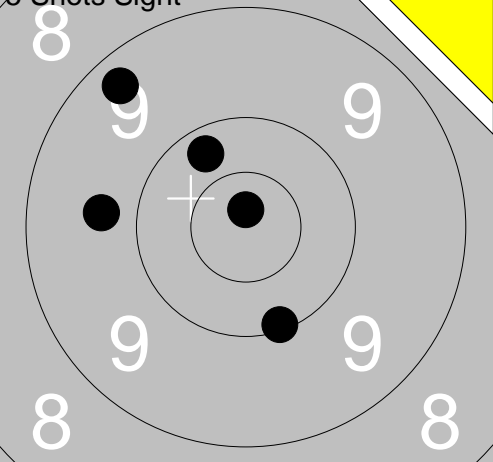
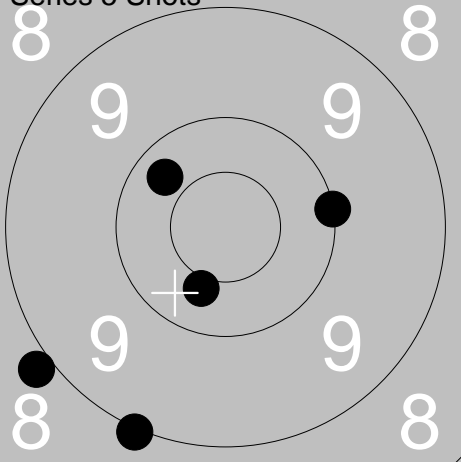
<p>5 Shots Sight</p> 	<p>1: 9.3 ↗ 2: 9.7 ← 3: 10.2 ↗ 4: *10.8 ↑ 5: 10.1 ↓</p>	<p>1. Series 5 Shots</p> 	<p>1: 10.0 → 2: 8.9 ↙ 3: 10.4 ↓ 4: 9.0 ↓ 5: 10.3 ↗</p>
Series 48.0		Series 47.0	
Total 0.0		Total 47.0	

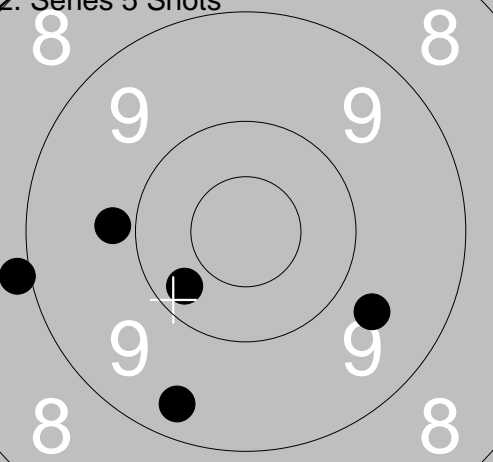
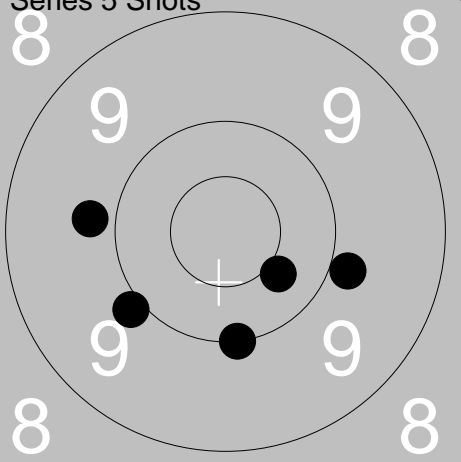
<p>2. Series 5 Shots</p> 	<p>1: 8.9 ← 2: 9.7 → 3: 9.3 ↓ 4: 9.8 ← 5: 10.3 ↙</p>	<p>3. Series 5 Shots</p> 	<p>1: 10.0 ↓ 2: 9.8 ← 3: 9.9 ↙ 4: 9.9 → 5: 10.4 ↘</p>
Series 45.0		Series 47.0	
Total 92.0		Total 139.0	

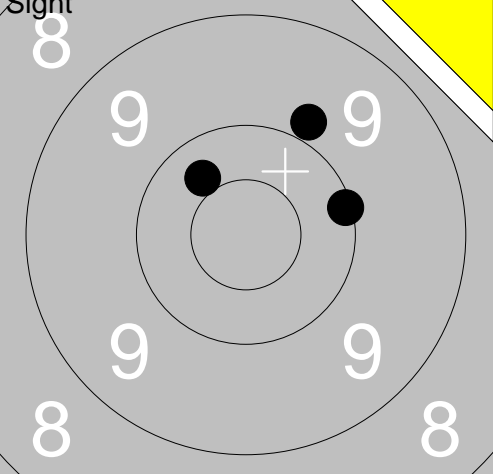
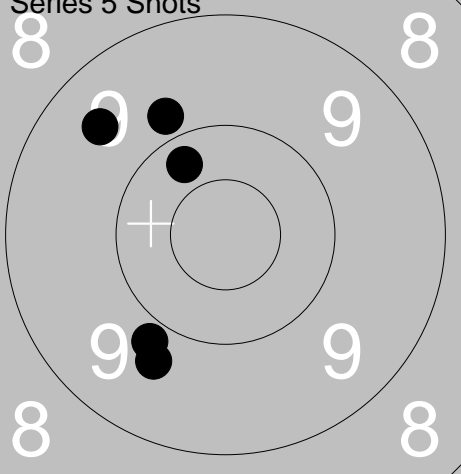
<p>Sight</p> 	<p>1: 10.4 ↗ 2: 10.1 → 3: 9.9 ↗</p>	<p>1. Series 5 Shots</p> 	<p>1: 10.3 ↗ 2: 9.8 ↙ 3: 9.5 ↗ 4: 9.7 ↙ 5: 9.8 ↗</p>
Series 29.0		Series 46.0	
Total 139.0		Total 185.0	

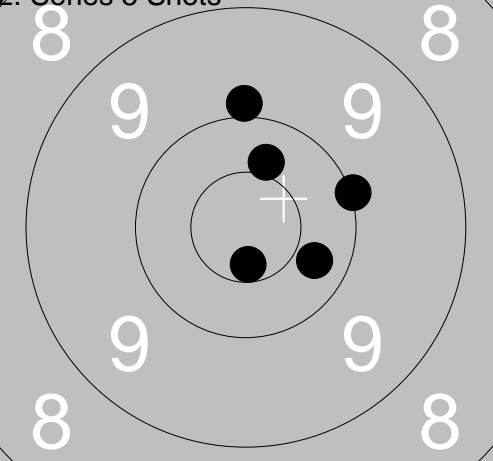
<p>2. Series 5 Shots</p> 	<p>1: 9.9 ↑ 2: *10.6 ↓ 3: 10.4 ↑ 4: 10.0 → 5: 10.3 ↘</p>		
Series 49.0			
Total 234.0			

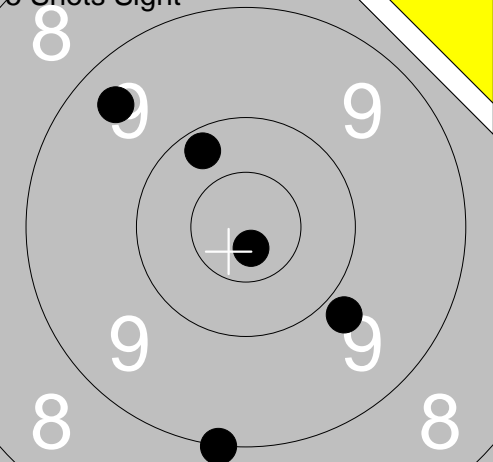
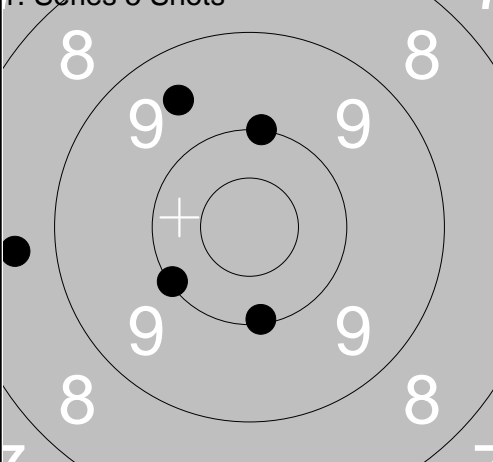
<p>5 Shots Sight</p> 	<p>1: 10.2 ↗ 2: 9.4 ↗ 3: *10.8 ↓ 4: 9.8 ↘ 5: 9.0 ↓</p>	<p>1. Series 5 Shots</p> 	<p>1: 10.0 ↑ 2: 10.1 ↙ 3: 9.5 ↗ 4: 8.6 ← 5: 10.1 ↓</p>
Series 47.0		Series 47.0	
Total 0.0		Total 47.0	

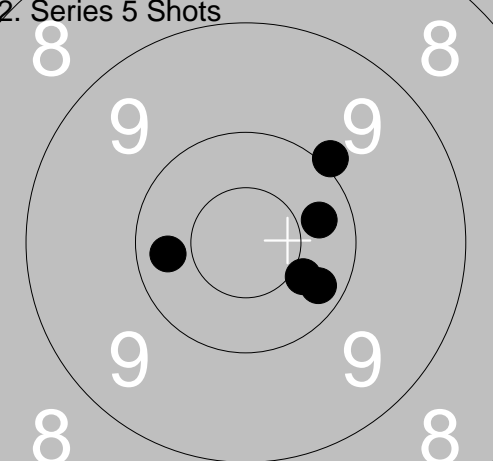
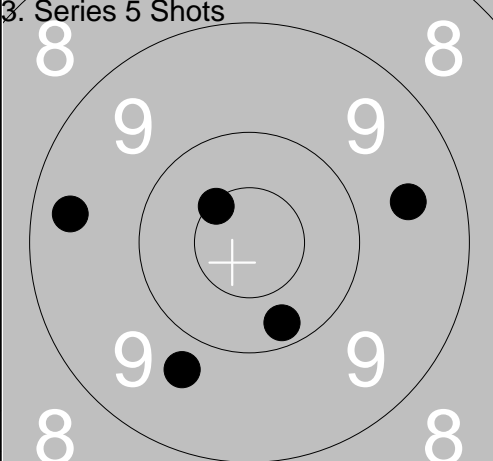
<p>2. Series 5 Shots</p> 	<p>1: 10.3 ← 2: 10.2 ↘ 3: 10.0 ↗ 4: 10.3 → 5: 10.4 ↘</p>	<p>3. Series 5 Shots</p> 	<p>1: 9.7 ↓ 2: *10.5 ↗ 3: 9.4 ← 4: 10.2 ↓ 5: 9.5 →</p>
Series 50.0		Series 47.0	
Total 97.0		Total 144.0	

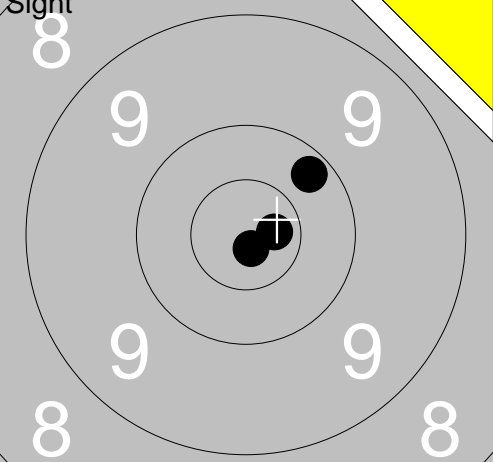
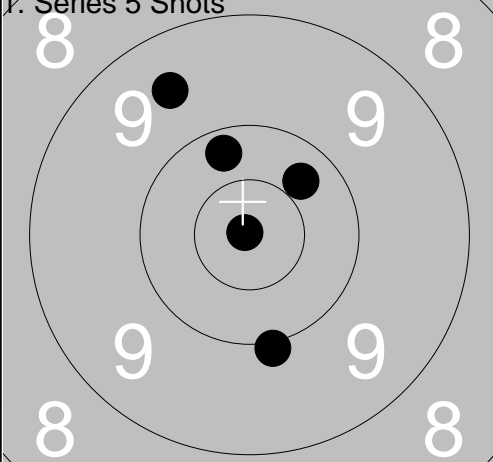
<p>Sight</p> 	<p>1: *10.8 ↓ 2: 10.2 ↗ 3: *10.7 →</p>	<p>1. Series 5 Shots</p> 	<p>1: 10.3 ↗ 2: 10.2 ↑ 3: *10.9 ↙ 4: 9.5 ↗ 5: 10.0 ↓</p>
Series 30.0		Series 49.0	
Total 144.0		Total 193.0	

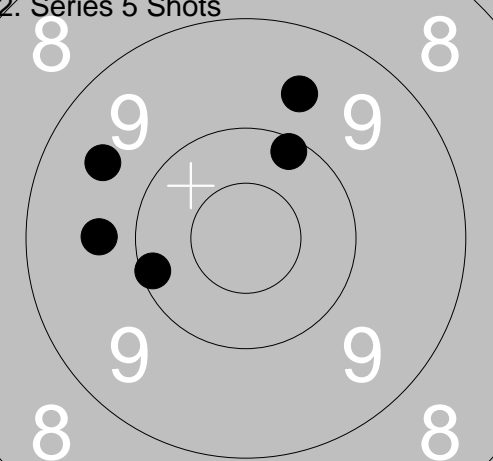
<p>2. Series 5 Shots</p> 	<p>1: 9.7 ← 2: 10.1 ← 3: 9.6 ↙ 4: 9.6 ↑ 5: 10.1 ↗</p>		
Series 47.0			
Total 240.0			

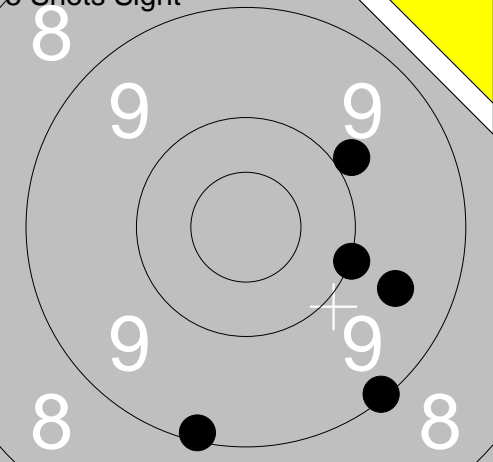
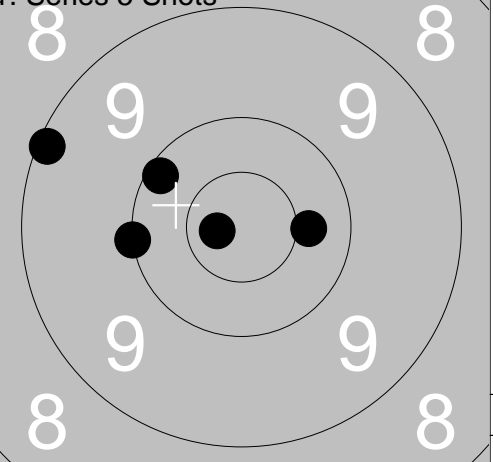
<p>5 Shots Sight</p> 	<p>1: 9.9 ↗ 2: 10.0 → 3: 9.1 ↓ 4: 9.1 ↘ 5: 9.6 ↘</p>	<p>1. Series 5 Shots</p> 	<p>1: *10.7 ← 2: 10.1 ↖ 3: 9.1 ↖ 4: 10.0 ← 5: 10.4 →</p>
Series 46.0		Series 49.0	
Total 0.0		Total 49.0	

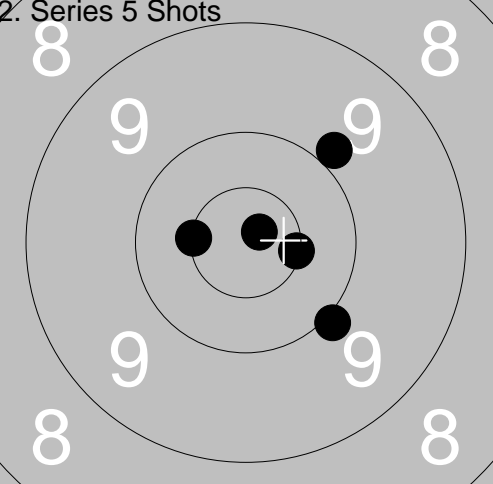
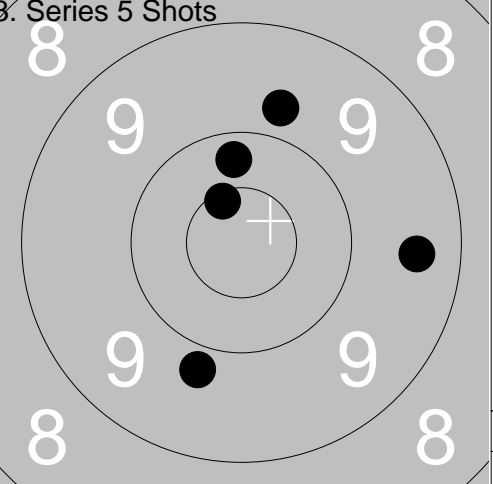
<p>2. Series 5 Shots</p> 	<p>1: *10.5 ← 2: *10.8 ↗ 3: *10.5 → 4: 9.9 ↗ 5: 10.0 ↘</p>	<p>3. Series 5 Shots</p> 	<p>1: 9.8 ↓ 2: *10.6 ↖ 3: 9.8 ↗ 4: 10.3 ↗ 5: 9.4 →</p>
Series 49.0		Series 47.0	
Total 98.0		Total 145.0	

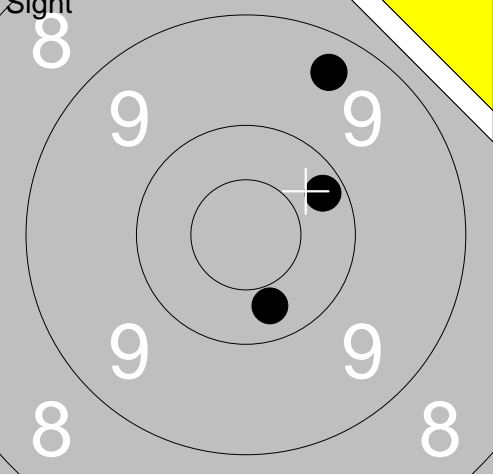
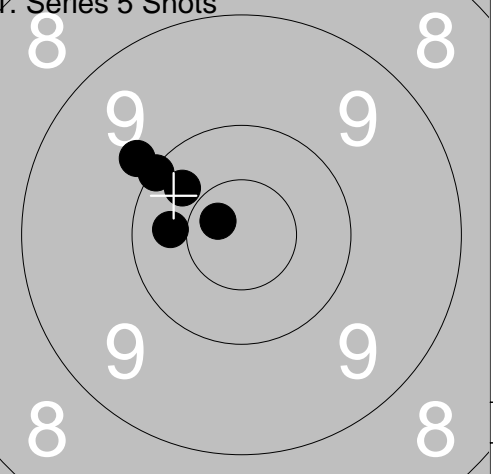
<p>Sight</p> 	<p>1: 10.2 ↗ 2: 9.4 ↗ 3: 10.3 ↓</p>	<p>1. Series 5 Shots</p> 	<p>1: *10.7 ↖ 2: 9.9 ↖ 3: 10.1 ↖ 4: 10.3 ↖ 5: 10.4 ←</p>
Series 29.0		Series 49.0	
Total 145.0		Total 194.0	

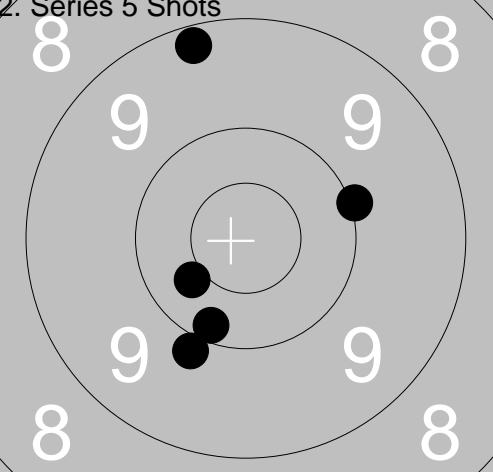
<p>2. Series 5 Shots</p> 	<p>1: 10.4 ← 2: 10.2 ↓ 3: 9.2 ↗ 4: 10.0 → 5: 9.9 ↓</p>		
Series 48.0			
Total 242.0			

<p>5 Shots Sight</p>	<p>1: 10.2 ← 2: 9.2 ← 3: 8.9 ↘ 4: *10.6 ↘ 5: *10.6 ↘</p>	<p>1. Series 5 Shots</p>	<p>1: 10.0 ↓ 2: 9.7 ↑ 3: 10.3 ↓ 4: *10.8 ← 5: 9.0 ↗</p>
Series 47.0		Series 48.0	
Total 0.0		Total 48.0	

<p>2. Series 5 Shots</p>	<p>1: 9.6 ↓ 2: 8.7 → 3: 10.2 ↓ 4: 9.7 → 5: *10.6 ↗</p>	<p>3. Series 5 Shots</p>	<p>1: 10.2 ↓ 2: *10.4 ↗ 3: 9.1 ↑ 4: 9.8 ↗ 5: 10.2 →</p>
Series 46.0		Series 48.0	
Total 94.0		Total 142.0	

<p>Sight</p>	<p>1: 10.3 ← 2: *10.8 ← 3: 10.0 ↑</p>	<p>1. Series 5 Shots</p>	<p>1: 9.6 ← 2: 10.4 ↗ 3: 10.2 → 4: 9.8 ↗ 5: 10.1 ↗</p>
Series 30.0		Series 48.0	
Total 142.0		Total 190.0	

<p>2. Series 5 Shots</p>	<p>1: 10.3 ↓ 2: *10.5 ↑ 3: 10.3 ↗ 4: 8.9 ↗ 5: *10.6 ↘</p>		
Series 48.0			
Total 238.0			